

NOT FOR RESELL

THIS MANUAL WAS GIVEN OUT FOR FREE
YOU CAN FIND THIS ON THE INTERNET
IF YOU PAID FOR THIS ON EBAY OR ANY
PLACE. GET YOUR MONEY BACK.

DONT LET SOME DUMBASS MAKE
MONEY ON SHIT THAT YOU CAN GET
FOR FREE.



1993 Service Manual
First Edition

88hf , SPOONMAN, FFSLIDE

PREMIUM

INTRODUCTION

How to Use This Manual -

This manual is divided into 23 sections. Each section is marked with a black tab that lines up with its corresponding thumb index tab on this page and the back cover. You can quickly find the first page of each section without looking through a full table of contents. The symbols printed at the top corner of each page can also be used as a quick reference system.

Each section includes:

1. A table of contents, or an exploded view index showing:
 - Parts disassembly sequence.
 - Bolt torques and thread sizes.
 - Page references to descriptions in text.
2. Disassembly/assembly procedures and tools.
3. Inspection.
4. Testing/troubleshooting.
5. Repair.
6. Adjustments.

Special Information

⚠ WARNING Indicates a strong possibility of severe personal injury or loss of life if instructions are not followed.

CAUTION: Indicates a possibility of personal injury or equipment damage if instructions are not followed.

NOTE: Gives helpful information.

CAUTION: Detailed descriptions of *standard workshop* procedures, safety principles and service operations are not included. Please note that this manual contains warnings and cautions against some specific service methods which could cause **PERSONAL INJURY**, damage a vehicle or make it unsafe. Please understand that these warnings cannot cover all conceivable ways in which service, whether or not recommended by HONDA might be done, or of the possible hazardous consequences of every conceivable way, nor could HONDA investigate all such ways. Anyone using service procedures or tools, whether or not recommended by HONDA, *must satisfy himself thoroughly* that neither personal safety nor vehicle safety will be jeopardized.

All information contained in this manual is based on the latest product information available at the time of printing. We reserve the right to make changes at any time without notice. No part of this publication may be reproduced, stored in retrieval system, or transmitted, in any form by any means, electronic, mechanical, photocopying, recording, or otherwise, without the prior written permission of the publisher. This includes text, figures and tables.

First Edition 9/92 1516 pages
All Rights Reserved
Specifications apply to U.S.A. and Canada

HONDA MOTOR CO.,LTD.
Service Publication Office

General Info



Special Tools



Specifications

specs

Maintenance



Engine



Cooling



Fuel and Emissions



* Transaxle



* Steering



Suspension



* Brakes
(Including ABS)



* Body



* Heater and
Air Conditioning



* Electrical
(Including SRS)



As sections with * include SRS components, special precautions are required when servicing.



General Information

Chassis and Paint Codes	1-2
Identification Number Locations	1-4
Warning/Caution Labels	1-5
Lift and Support Points	
Lift	1-9
Floor Jack	1-10
Safety Stands	1-11
Towing	1-12
Service Precautions	
Handling of Special Nuts and Bolts	1-13

Chassis and Paint Codes

U.S. Model

Vehicle Identification Number

JHMBA814*PC000001

Manufacturer, Make and

Type of Vehicle

JHM: HONDA MOTOR CO., LTD.
HONDA, Passenger Car

Model Line

BA8: Prelude 2.2 l
BB1: Prelude 2.2 l VTEC
BB2: Prelude 2.3 l

Body and Transmission Type

1: 2-door 5-speed Manual
2: 2-door 4-speed Automatic

Vehicle Grade

4: Prelude S
5: Prelude Si
6: Prelude Si 4WS
7: Prelude Si VTEC

Check Digit

Model Year

P: 1993

Factory Code

C: Saitama Factory in Japan

Serial Number

Engine Number

F22A1-9200001

Engine Type

F22A1: 2.2 l SOHC Sequential Multiport Fuel-injected engine
H22A1: 2.2 l DOHC VTEC Sequential Multiport Fuel-injected engine
H23A1: 2.3 l DOHC Sequential Multiport Fuel-injected engine

Emission Group

100: California with H22A1 engine
130: 49ST with H22A1 engine
200: California with H23A1 engine
230: 49ST with H23A1 engine
920: California with F22A1 engine
923: 49ST with F22A1 engine

Serial Number

Transmission Number

M2F4-1000001

Transmission Type

M2F4: Manual with H22A1 engine
M2L5: Manual with F22A1 engine
M2S4: Manual with H23A1 engine
MP1A: Automatic

Serial Number

M2F4: 1000001 ~
Except M2F4: 2000001 ~

Vehicle Identification Number and Federal Motor Vehicle Safety Standard Certification.

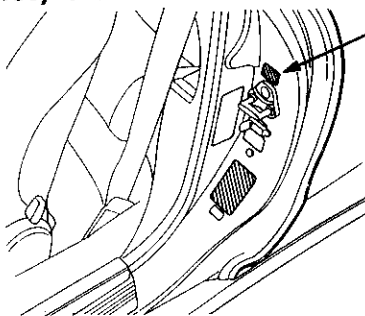

Paint Code

COLOR
B-64P

Paint Code

Paint Code	Color
B-64P	Fresco Blue Pearl
BG-23M	Brittany Blue Metallic
NH-503P	Granada Black Pearl
NH-552M	Seabling Silver Metallic
NH-538	Frost White
R-81	Mirano Red

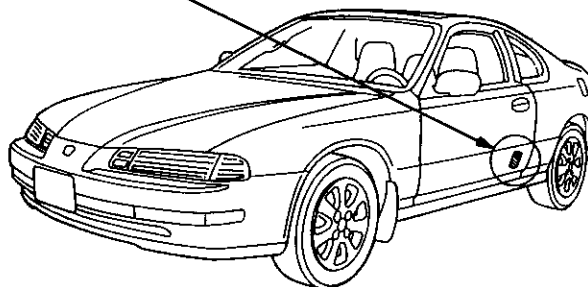



Canada Model

Vehicle Identification Number JHMB A814*PC800001

Manufacturer, Make and Type of Vehicle
 JHM: HONDA MOTOR CO., LTD.
 HONDA, Passenger Car

Model Line
 BA8: Prelude 2.2 ℓ
 BB1: Prelude 2.2 ℓ VTEC
 BB2: Prelude 2.3 ℓ

Body and Transmission Type
 1: 2-door 5-speed Manual
 2: 2-door 4-speed Automatic

Vehicle Grade
 4: Prelude
 5: Prelude SR
 6: Prelude SR 4WS
 7: Prelude SR-V

Check Digit _____

Model Year
 P: 1993

Factory Code _____

C: Saitama Factory in Japan

Serial Number _____

Engine Number F22A1-9280001

Engine Type
 F22A1: 2.2 ℓ SOHC Sequential Multiport Fuel-injected engine
 H22A1: 2.2 ℓ DOHC VTEC Sequential Multiport Fuel-injected engine
 H23A1: 2.3 ℓ DOHC Sequential Multiport Fuel-injected engine

Serial Number
 F22A1 engine: 9280001 ~
 H22A1 engine: 1700001 ~
 H23A1 engine: 2700001 ~

Transmission Number M2F4-1000001

Transmission Type
 M2F4: Manual with H22A1 engine
 M2L5: Manual with F22A1 engine
 M2S4: Manual with H23A1 engine
 MP1A: Automatic

Serial Number
 M2F4: 1000001 ~
 Except M2F4: 2000001 ~



Paint Code
COLOR
B-64P

Paint Code	Color
B-64P	Fresco Blue Pearl
BG-23M	Brittany Blue Metallic
NH-503P	Granada Black Pearl
NH-552M	Seabling Silver Metallic
NH-538	Frost White
R-81	Mirano Red

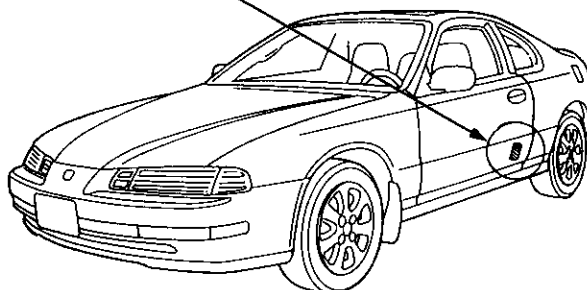

Identification Number Locations

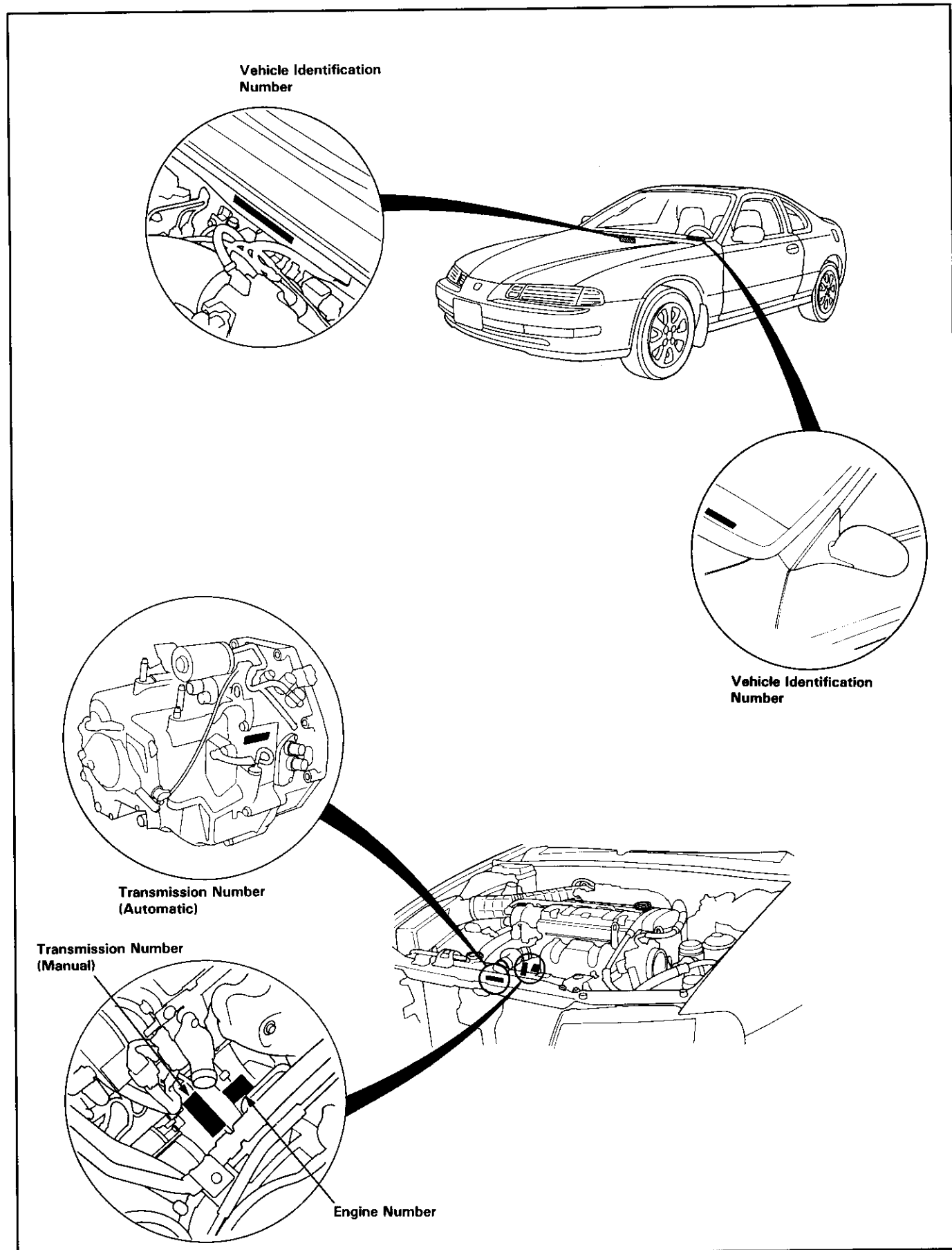

Warning/Caution Label Locations

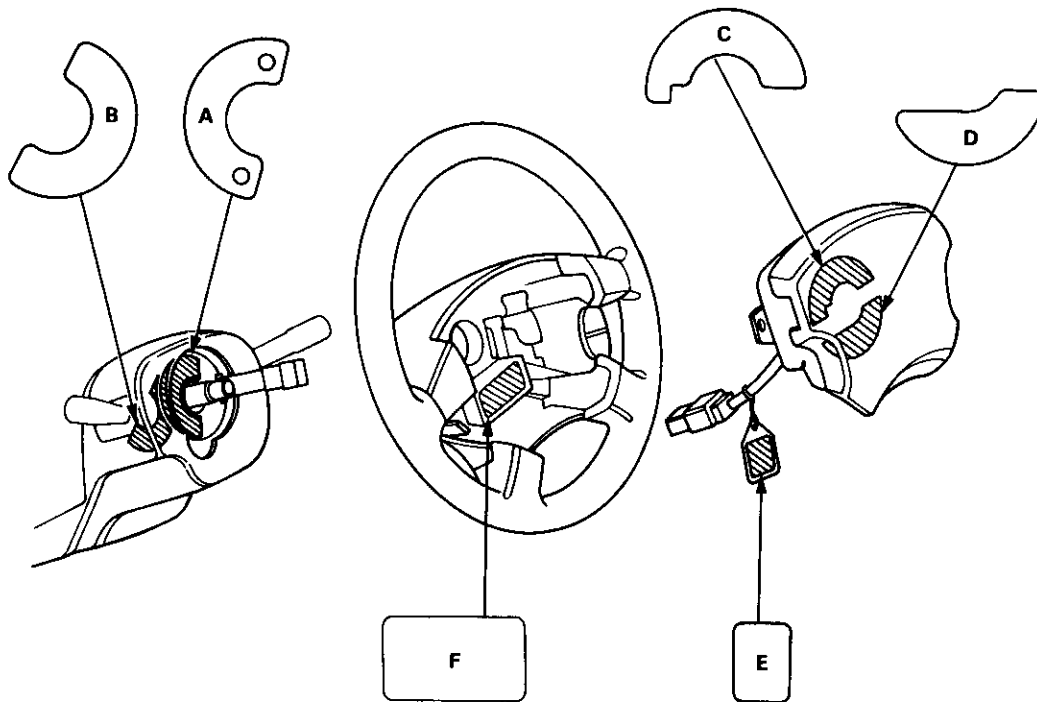

A: CABLE REEL CAUTION A

CAUTION: **SRS**
BEFORE INSTALLING CABLE REEL:
● CENTER THE FRONT WHEELS.
● ALIGN THE MARKS.
● READ SERVICE MANUAL.

B: CABLE REEL CAUTION B

CAUTION: **SRS**
NO SERVICEABLE PARTS INSIDE; DO NOT DISASSEMBLE OR TAMPER.

C: DRIVER MODULE DANGER

⚠ DANGER
EXPLOSIVE/FLAMMABLE
CONTACT WITH ACID, WATER OR HEAVY METALS SUCH AS COPPER, LEAD OR MERCURY MAY PRODUCE HARMFUL AND IRRITATING GASES OR EXPLOSIVE COMPOUNDS. STORAGE TEMPERATURES MUST NOT EXCEED 200°F (100°C). FOR PROPER HANDLING, STORAGE AND DISPOSAL PROCEDURES REFER TO SERVICE MANUAL, SRS SUPPLEMENT.
POISON
CONTAINS POISONOUS SODIUM AZIDE AND POTASSIUM NITRATE.
FIRST AID
IF CONTENTS ARE SWALLOWED, INDUCE VOMITING. FOR EYE CONTACT, FLUSH EYES WITH WATER FOR 15 MINUTES. IF GASES (FROM ACID OR WATER CONTACT) ARE INHALED, SEEK FRESH AIR. IN EVERY CASE, GET PROMPT MEDICAL ATTENTION.
KEEP OUT OF REACH OF CHILDREN.

D: DRIVER MODULE WARNING

⚠ WARNING
THE AIRBAG INFLATOR IS EXPLOSIVE AND, IF ACCIDENTALLY DEPLOYED, CAN SERIOUSLY HURT OR KILL YOU.
● DO NOT USE ELECTRICAL TEST EQUIPMENT OR PROBING DEVICES. THEY CAN CAUSE ACCIDENTAL DEPLOYMENT.
● NO SERVICEABLE PARTS INSIDE. DO NOT DISASSEMBLE.
● PLACE AIRBAG UPRIGHT WHEN REMOVED.
● FOLLOW SERVICE MANUAL INSTRUCTIONS CAREFULLY.

E: INFLATOR WARNING TAG

⚠ WARNING
ACCIDENTAL AIRBAG DEPLOYMENT CAN SERIOUSLY HURT OR KILL YOU. INSTALL THE RED SERVICE CONNECTOR WHEN THE INFLATOR HARNESS IS DISCONNECTED.

F: STEERING WHEEL NOTICE

NOTICE
IMPROPER STEERING WHEEL REMOVAL OR INSTALLATION CAN DAMAGE SRS COMPONENTS. FOLLOW SERVICE MANUAL INSTRUCTION CAREFULLY.

(cont'd)

Warning/Caution Label Locations

(cont'd)

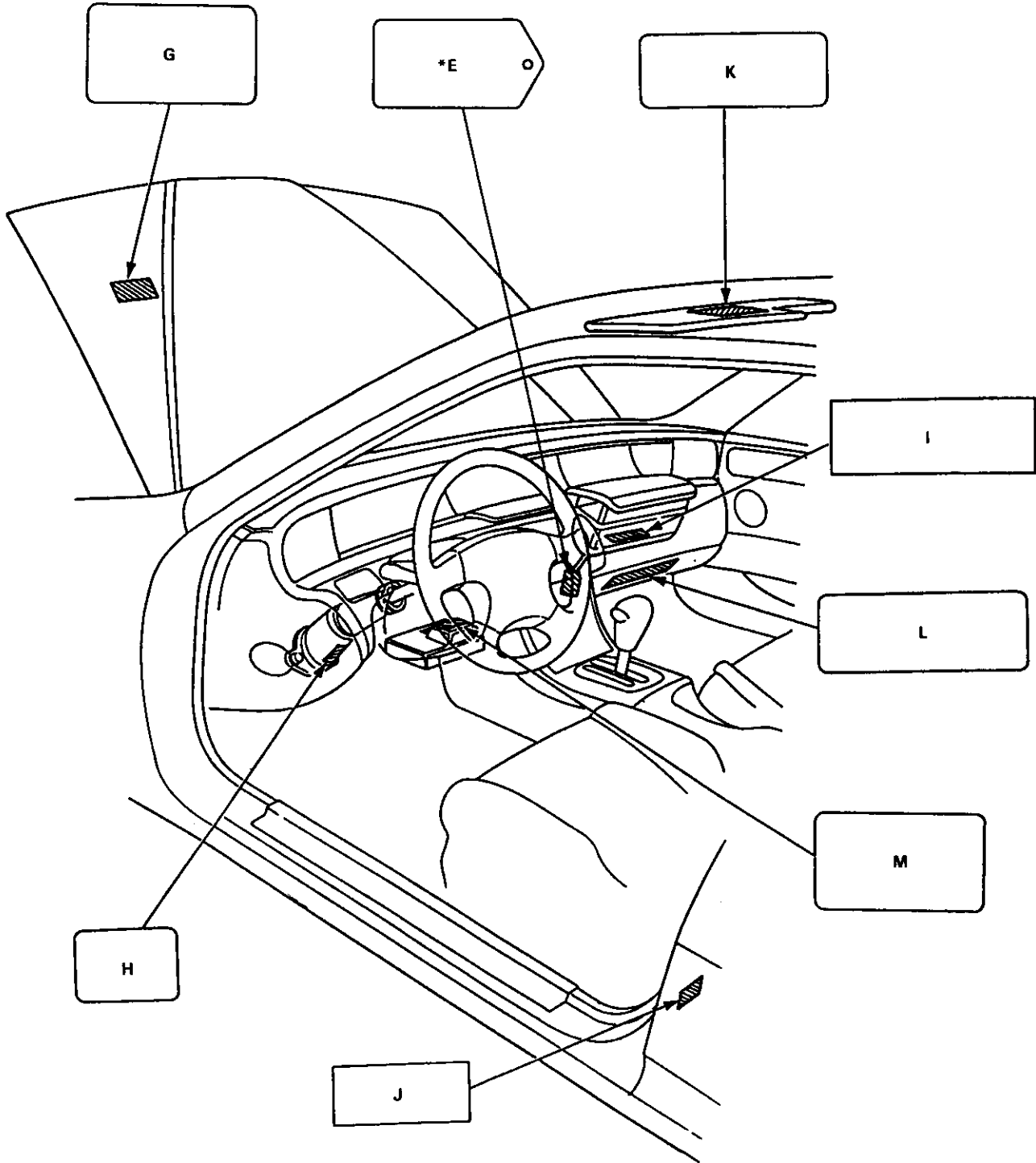

*E: Inflator warning tag (Refer to page 1-5).



G: SRS WARNING (ENGINE HOOD)

SUPPLEMENTAL RESTRAINT SYSTEM (SRS)
THIS VEHICLE IS EQUIPPED WITH DRIVER AND FRONT SEAT PASSENGER AIRBAGS AND FRONT SEAT BELT TENSIONER SYSTEMS.
ALL SRS ELECTRICAL WIRING AND CONNECTORS ARE COLORED YELLOW.
TAMPERING WITH, DISCONNECTING OR USING ELECTRICAL TEST EQUIPMENT ON THE SRS WIRING CAN MAKE THE SYSTEM INOPERATIVE OR CAUSE ACCIDENTAL FIRING OF THE INFLATOR.

⚠ WARNING
THE AIRBAG INFLATOR IS EXPLOSIVE AND, IF ACCIDENTALLY DEPLOYED, CAN SERIOUSLY HURT YOU. FOLLOW SERVICE MANUAL INSTRUCTIONS CAREFULLY.

H: STEERING COLUMN CAUTION

CAUTION **SRS**
TO AVOID DAMAGING THE SRS CABLE OR REEL, WHICH COULD MAKE THE SYSTEM INOPERATIVE, REMOVE THE STEERING WHEEL BEFORE REMOVING THE STEERING SHAFT CONNECTOR BOLT.

I: FRONT SEAT PASSENGER AIRBAG MODULE DANGER

⚠ DANGER
EXPLOSIVE/FLAMMABLE
CONTACT WITH ACID, WATER OR HEAVY METALS SUCH AS COPPER, LEAD OR MERCURY MAY PRODUCE HARMFUL AND IRRITATING GASES OR EXPLOSIVE COMPOUNDS. STORAGE TEMPERATURES MUST NOT EXCEED 200°F (100°C) FOR PROPER HANDLING, STORAGE AND DISPOSAL PROCEDURES REFER TO SERVICE MANUAL, SRS SUPPLEMENT.
POISON
CONTAINS POISONOUS SODIUM AZIDE AND POTASSIUM NITRATE.
FIRST AID
IF CONTENTS ARE SWALLOWED, INDUCE VOMITING. FOR EYE CONTACT, FLUSH EYES WITH WATER FOR 15 MINUTES. IF GASES (FROM ACID OR WATER CONTACT) ARE INHALED, SEEK FRESH AIR. IN EVERY CASE, GET PROMPT MEDICAL ATTENTION.
KEEP OUT OF REACH OF CHILDREN.

⚠ WARNING
THE AIRBAG INFLATOR IS EXPLOSIVE AND, IF ACCIDENTALLY DEPLOYED, CAN SERIOUSLY HURT OR KILL YOU.
● DO NOT USE ELECTRICAL TEST EQUIPMENT OR PROBING DEVICES. THEY CAN CAUSE ACCIDENTAL DEPLOYMENT.
● NO SERVICEABLE PARTS INSIDE. DO NOT DISASSEMBLE.
● PLACE AIRBAG UPRIGHT WHEN REMOVED.
● FOLLOW SERVICE MANUAL INSTRUCTIONS CAREFULLY.

J: LABEL

AIRBAG
type:

K: DRIVER INFORMATION (SUNVISOR)

SRS ALWAYS WEAR YOUR SEAT BELT
● THIS CAR IS EQUIPPED WITH A DRIVER AIRBAG AS A SUPPLEMENTAL RESTRAINT SYSTEM (SRS).
● IT IS DESIGNED TO SUPPLEMENT THE SEAT BELT.
● BEFORE DRIVING READ LABEL INSIDE THE GLOVE BOX.

***K: DRIVER INFORMATION**

SRS ALWAYS WEAR YOUR SEAT BELT
● THIS CAR IS EQUIPPED WITH A DRIVER AIRBAG AND A FRONT SEAT PASSENGER AIRBAG AS A SUPPLEMENTAL RESTRAINT SYSTEM (SRS).
● IT IS DESIGNED TO SUPPLEMENT THE SEAT BELT.
● BEFORE DRIVING READ LABEL INSIDE THE GLOVE BOX.

L: GLOVE BOX INFORMATION

DRIVER'S AIRBAG INFORMATION **SRS**
● SUPPLEMENTAL RESTRAINT SYSTEM (SRS) CAN PROVIDE ADDITIONAL PROTECTION FOR THE DRIVER IN A FRONTAL COLLISION. A FUNCTIONAL DESCRIPTION OF THE SRS IS IN YOUR OWNER'S MANUAL.
● THE SYSTEM MUST BE INSPECTED TEN YEARS AFTER DATE OF MANUFACTURE, AS NOTED ON THE CERTIFICATION PLATE.
● ANY REPAIR, INSPECTION OR NEARBY ACCESSORY INSTALLATION SHOULD BE DONE BY AN AUTHORIZED HONDA DEALER.
● IF YOUR SRS INDICATOR:
• LIGHTS WHILE DRIVING OR FLASHES;
• FAILS TO LIGHT OR STAYS ON AFTER THE IGNITION IS FIRST TURNED ON;
SEE YOUR AUTHORIZED HONDA DEALER.

***L: GLOVE BOX INFORMATION**

DRIVER'S AND FRONT SEAT PASSENGER'S AIRBAG INFORMATION **SRS**
● SUPPLEMENTAL RESTRAINT SYSTEM (SRS) CAN PROVIDE ADDITIONAL PROTECTION FOR THE DRIVER AND FRONT SEAT PASSENGER IN A FRONTAL COLLISION. A FUNCTIONAL DESCRIPTION OF THE SRS IS IN YOUR OWNER'S MANUAL.
● THE SYSTEM MUST BE INSPECTED TEN YEARS AFTER DATE OF MANUFACTURE, AS NOTED ON THE CERTIFICATION PLATE.
● ANY REPAIR, INSPECTION OR NEARBY ACCESSORY INSTALLATION SHOULD BE DONE BY AN AUTHORIZED HONDA DEALER.
● IF YOUR SRS INDICATOR:
• LIGHTS WHILE DRIVING OR FLASHES;
• FAILS TO LIGHT OR STAYS ON AFTER THE IGNITION IS FIRST TURNED ON;
• SEE YOUR AUTHORIZED HONDA DEALER.

M: SRS UNIT CAUTION

CAUTION **SRS**
● NO SERVICEABLE PARTS INSIDE.
● DO NOT DISASSEMBLE OR TAMPER.
● DO NOT DROP.
● STORE IN A CLEAN, DRY AREA.

*This version of the label is used on cars with front passenger airbag.

Warning/Caution Label Locations

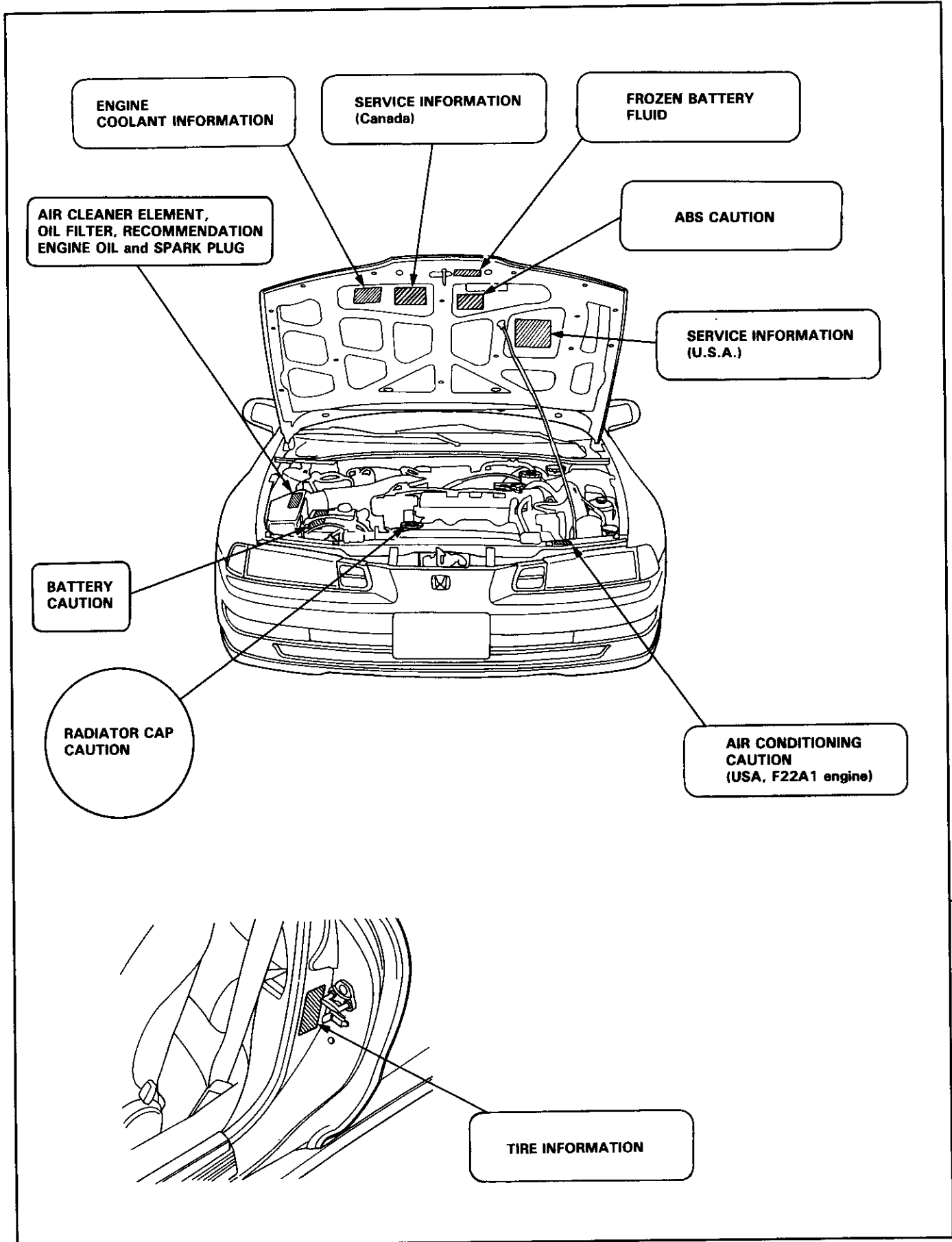



Lift and Support Points

Lift

⚠ WARNING When heavy rear components such as suspension, fuel tank, spare tire and trunk lid are to be removed, place additional weight in the trunk before hoisting. When substantial weight is removed from the rear of the car, the center of gravity may change and can cause the car to tip forward on the hoist.

NOTE: Since each tire/wheel assembly weighs approximately 30 lbs (14 kg), placing the front wheels in the trunk can assist with weight distribution.

1. Place the lift blocks as shown.
2. Raise the hoist a few inches (centimeters) and rock the car to be sure it is firmly supported.
3. Raise the hoist to full height and inspect lift points for solid support.

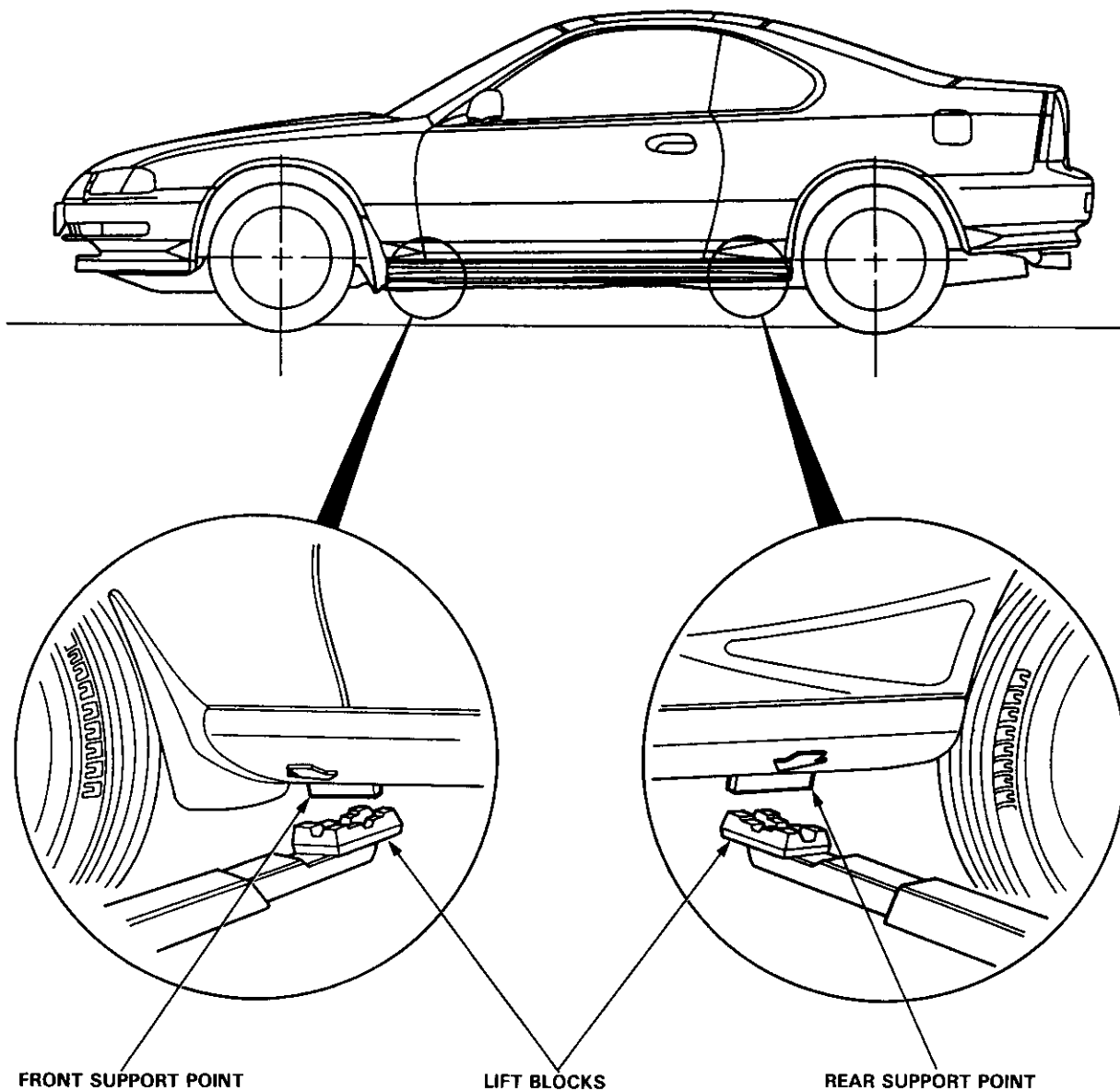

(cont'd)

Lift and Support Points

Floor Jack

1. Set the parking brake and block the wheels that are not being lifted.
2. When lifting the rear of the car, put the gearshift lever in reverse (Automatic transmission in **P** position).
3. Raise the car high enough to insert the safety stands.
4. Adjust and place the safety stands as shown on page 1-11 so the car will be approximately level, then lower the car onto them.

⚠ WARNING

- Always use safety stands when working on or under any vehicle that is supported only by a jack.
- Never attempt to use a bumper jack for lifting or supporting the car.

Front

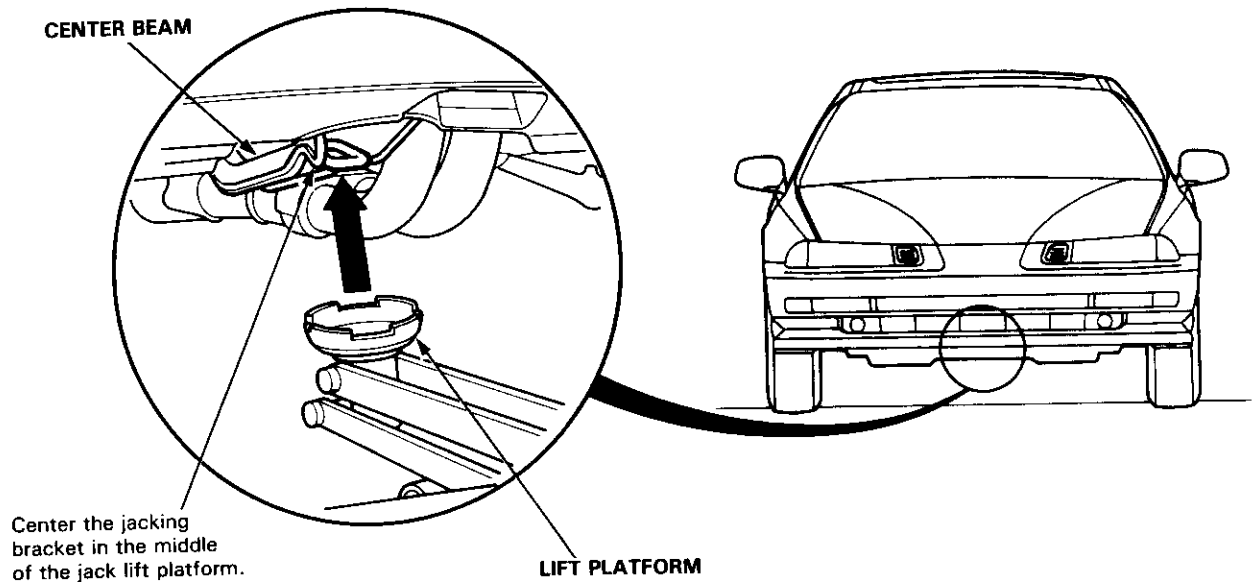

Rear

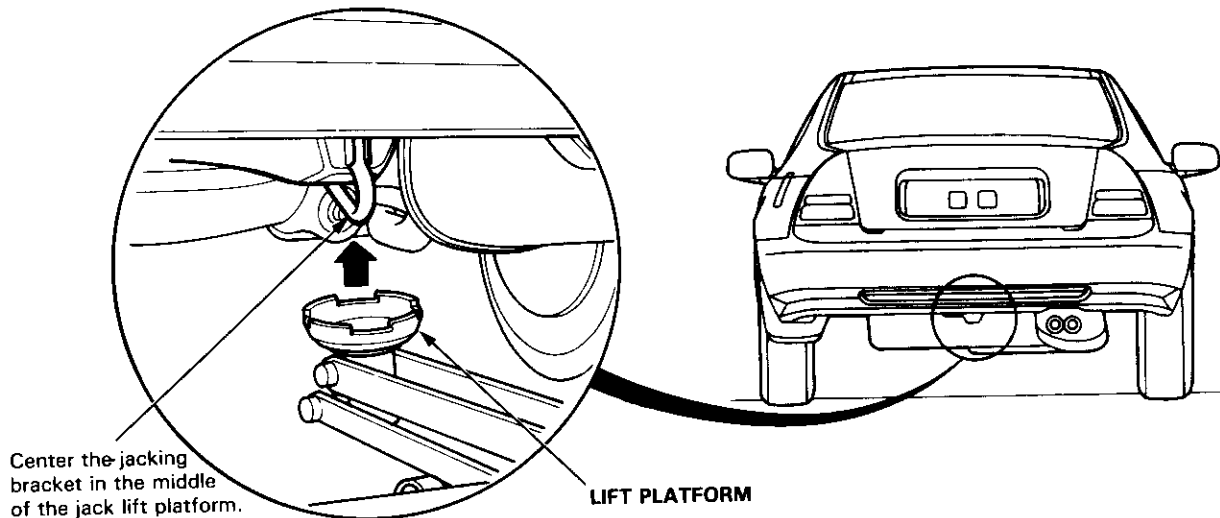



Safety Stands

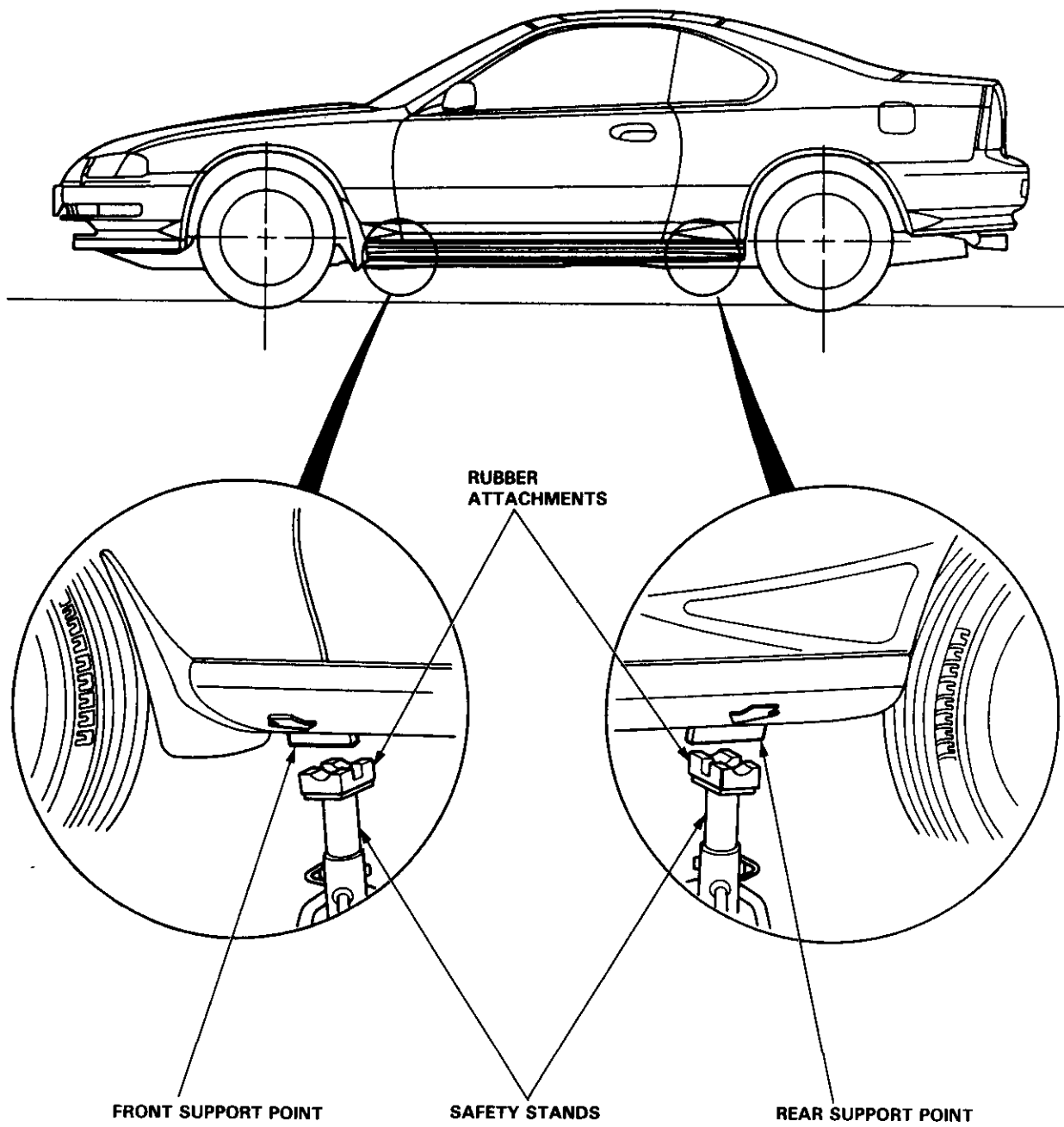

Towing

If the car needs to be towed, call a professional towing service. Never tow the car behind another car with just a rope or chain. It is very dangerous.

Emergency Towing

There are three popular methods of towing a car:

Flat-bed Equipment — The operator loads the car on the back of a truck. This is the best way of transporting the car.

Wheel Lift Equipment — The tow truck uses two pivoting arms that go under the tires (front or rear) and lifts them off the ground. The other two wheels remain on the ground.

Sling-type Equipment — The tow truck uses metal cables with hooks on the ends. These hooks go around parts of the frame or suspension and the cables lift that end of the car off the ground. The car's suspension and body can be seriously damaged if this method of towing is attempted.

If the car cannot be transported by flat-bed, it should be towed with the front wheels off the ground. If due to damage, the car must be towed with the front wheels on the ground, do the following:

5-speed Manual Transmission

- Release the parking brake.
- Shift the transmission to Neutral.

Automatic Transmission

- Release the parking brake.
- Start the engine.
- Shift to **D4** position, then **N** position.
- Turn off the engine.

NOTICE: Improper towing preparation will damage the transmission. Follow the above procedure exactly. If you cannot shift the transmission or start the engine (automatic transmission), your car must be transported on a flat-bed.

- It is best to tow the car no farther than 50 miles (80km), and keep the speed below 35 mph (55 km/h).

NOTICE: Trying to lift or tow the car by the bumpers will cause serious damage. The bumpers are not designed to support the car's weight.

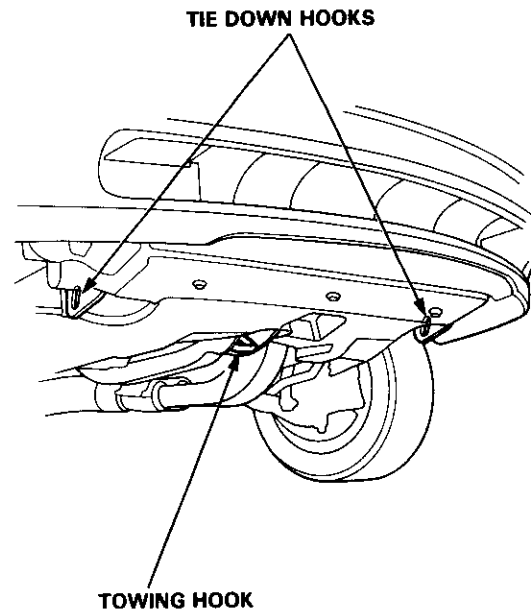



Service Precautions

Handling of Special Nuts and Bolts

Because the front sub frame sections on this car are constructed with aluminum alloys, use only the special "Dacro" type nuts and bolts recommended by Honda.

NOTE:

- Dacro finish can be identified by gray plating.
- Some Dacro finish bolts have a green coating on the thread section of the bolt for easier application. This type of bolt is called a "Torquer" bolt.
- Use of other types of nuts and bolts may cause electrolysis and corrosion, which in turn could cause the bolt to loosen.

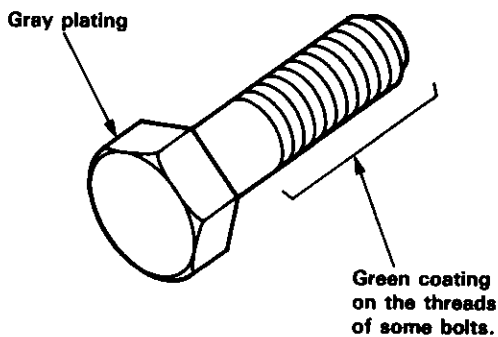

Gray plating: "Dacro" type
Gray plating + Green coating on the threads:
"Torquer" type

1. When replacing nuts and bolts, use only the same type.
2. Tighten the nuts and bolts with a torque wrench to the specifications provided in this manual.
3. Clean all thread ridges with a non wire type bristle brush. Foreign matter in the threads may cause the bolt to loosen.
4. Sections on this car requiring the use of Dacro nuts and bolts will be indicated by a (☆) in this manual.

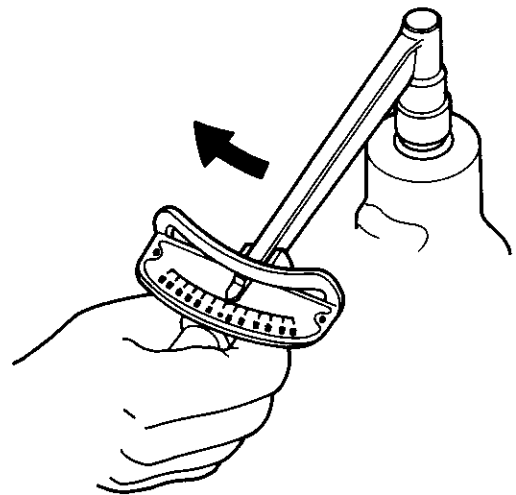

Specifications

Standards and Service Limits	3-2
Design Specifications	3-15
Body Specifications	3-18

Standards and Service Limits

Cylinder Head/Valve Train (F22A1 engine) — Section 6

MEASUREMENT		STANDARD (NEW)	SERVICE LIMIT	
Compression	250 rpm and wide open throttle kPa (kg/cm ² , psi)	Nominal Minimum Maximum variation	1,250 (12.5, 178) 950 (9.5, 135) 200 (2.0, 28)	
Cylinder head	Warpage Height	— 99.95-100.05 (3.935-3.939)	0.05 (0.002) —	
Camshaft	End play	0.05-0.15 (0.002-0.006)	0.5 (0.02)	
	Camshaft-to-holder oil clearance	0.050-0.089 (0.0020-0.0035)	0.15 (0.006)	
	Total runout	0.03 (0.001) max.	0.06 (0.002)	
	Cam lobe height	IN 38.526 (1.5168) EX 38.778 (1.5267)	— —	
Valve	Valve clearance	IN 0.23-0.28 (0.009-0.011) EX 0.27-0.30 (0.011-0.013)	— —	
	Valve stem O.D.	IN 5.485-5.495 (0.2159-0.2163)	5.455 (0.2148)	
		EX 5.450-5.460 (0.2146-0.2150)	5.420 (0.2134)	
	Stem-to-guide clearance	IN 0.020-0.045 (0.0008-0.0020)	0.08 (0.003)	
EX 0.055-0.080 (0.0022-0.0031)		0.12 (0.005)		
Valve seat	Width	IN 1.25-1.55 (0.049-0.061)	2.0 (0.08)	
		EX 1.25-1.55 (0.049-0.061)	2.0 (0.08)	
	Stem installed height	IN 48.245-48.715 (1.8994-1.9179)	48.965 (1.9278)	
		EX 50.315-50.785 (1.9809-1.9994)	51.035 (2.0092)	
Valve spring	Free length	IN 54.81 (2.158) *1 54.82 (2.158) *2	— —	
		EX 56.26 (2.215) *1 56.28 (2.216) *2	— —	
	Valve guide	I.D.	IN 5.515-5.530 (0.2171-0.2177)	5.53 (0.218)
			EX 5.515-5.530 (0.2171-0.2177)	5.53 (0.218)
Installed height		IN 23.75-24.25 (0.915-0.954)	—	
		EX 15.05-15.55 (0.593-0.612)	—	
Rocker arm	Arm-to-shaft clearance	IN 0.017-0.050 (0.0007-0.0020)	0.08 (0.003)	
		EX 0.018-0.054 (0.0007-0.0021)	0.08 (0.003)	

*1: CHUO HATSUJO manufactured valve spring.

*2: NIHON HATSUJO manufactured valve spring.

Cylinder Head/Valve Train (H23A1 engine) — Section 6

Unit of length: mm (in)

		MEASUREMENT	STANDARD (NEW)	SERVICE LIMIT
Compression	250 rpm and wide open throttle kPa (kg/cm ² , psi)	Nominal	1,250 (12.5, 178)	
		Minimum	950 (9.5, 135)	
		Maximum variation	200 (2.0, 28)	
Cylinder head	Warpage Height		—	0.05 (0.002)
			131.95-132.05 (5.195-5.199)	—
Camshaft	End play		0.05-0.15 (0.002-0.006)	0.5 (0.02)
		Camshaft-to-holder oil clearance	0.050-0.089 (0.0020-0.0035)* ¹ 0.100-0.139 (0.0039-0.0055)* ²	0.15 (0.006)* ¹ 0.20 (0.008)* ²
	Total runout	0.03 (0.001) max.	0.06 (0.002)	
	Cam lobe height	IN	33.661 (1.3252)	—
EX		33.725 (1.3278)	—	
Valve	Valve clearance	IN	0.07-0.11 (0.003-0.004)	—
		EX	0.15-0.19 (0.006-0.007)	—
	Valve stem O.D.	IN	6.580-6.590 (0.2591-0.2594)	6.55 (0.258)
		EX	6.550-6.560 (0.2579-0.2583)	6.52 (0.257)
	Stem-to-guide clearance	IN	0.02-0.05 (0.001-0.002)	0.08 (0.003)
		EX	0.05-0.08 (0.002-0.003)	0.11 (0.004)
Valve seat	Width	IN	1.25-1.55 (0.049-0.061)	2.0 (0.08)
		EX	1.25-1.55 (0.049-0.061)	2.0 (0.08)
	Stem installed height	IN	39.365-39.835 (1.5498-1.5683)	40.085 (1.5781)
		EX	39.195-39.635 (1.5431-1.5604)	39.885 (1.5703)
Valve spring	Free length	IN	47.14 (1.856)	
		EX	47.14 (1.856)	
Valve guide	I.D.	IN	6.61-6.63 (0.260-0.261)	6.70 (0.264)
		EX	6.61-6.63 (0.260-0.261)	6.70 (0.264)
	Installed height	IN	13.25-13.75 (0.522-0.541)	—
		EX	13.75-14.25 (0.541-0.561)	—

*1: Exhaust No. 5 journal.

*2: Except exhaust No. 5 journal.

(cont'd)

Standards and Service Limits

Cylinder Head/Valve Train (H22A1 engine) — Section 6

		MEASUREMENT		STANDARD (NEW)	SERVICE LIMIT
Compression	250 rpm and wide open throttle kPa (kg/cm ² , psi)	Nominal		1,300 (13.0, 185)	
		Minimum		950 (9.5, 135)	
		Maximum variation		200 (2.0, 28)	
Cylinder head	Warpage			—	0.05 (0.002)
	Height			141.95-142.05 (5.589-5.593)	—
Camshaft	End play			0.05-0.15 (0.002-0.006)	0.5 (0.02)
	Camshaft-to-holder oil clearance			0.050-0.089 (0.0020-0.0035)	0.15 (0.006)
	Total runout			0.03 (0.001) max.	0.06 (0.002)
	Cam lobe height	IN	Primary	34.041 (1.3402)	—
			Mid	36.856 (1.4510)	—
			Secondary	34.971 (1.3768)	—
		EX	Primary	33.745 (1.3285)	—
			Mid	36.323 (1.4300)	—
			Secondary	34.683 (1.3655)	—
Valve	Valve clearance		IN	0.15-0.19 (0.006-0.007)	—
			EX	0.17-0.21 (0.007-0.008)	—
	Valve stem O.D.		IN	5.475-5.485 (0.2156-0.2159)	5.445 (0.2144)
			EX	5.475-5.485 (0.2156-0.2159)	5.445 (0.2144)
	Stem-to-guide clearance		IN	0.025-0.055 (0.0010-0.0022)	0.08 (0.003)
			EX	0.050-0.080 (0.0020-0.0031)	0.11 (0.004)
Valve seat	Width		IN	1.25-1.55 (0.049-0.061)	2.0 (0.079)
			EX	1.25-1.55 (0.049-0.061)	2.0 (0.079)
	Stem installed height		IN	37.465-37.935 (1.4750-1.4935)	38.185 (1.5033)
			EX	37.165-37.635 (1.4632-1.4817)	37.885 (1.4915)
Valve spring	Free length	IN	Outer	45.16 (1.778) *1	—
				45.76 (1.802) *2	—
			Inner	41.78 (1.645) *1	—
				41.75 (1.644) *2	—
		EX	Outer	46.72 (1.839) *1	—
				46.74 (1.840) *2	—
			Inner	39.32 (1.548) *1	—
				39.28 (1.546) *2	—
Valve guide	I.D.		IN	5.510-5.530 (0.2169-0.2177)	5.55 (0.219)
			EX	5.535-5.555 (0.2179-0.2187)	5.60 (0.220)
	Installed height		IN	12.55-13.05 (0.494-0.514)	13.30 (0.524)
			EX	12.55-13.05 (0.494-0.514)	13.30 (0.524)
Rocker arm	Arm-to-shaft clearance		IN	0.025-0.052 (0.0010-0.0020)	0.08 (0.003)
			EX	0.025-0.052 (0.0010-0.0020)	0.08 (0.003)

*1: CHUO HATSUJO manufactured valve spring.

*2: NIHON HATSUJO manufactured valve spring.

Engine Block — Section 7

		MEASUREMENT	STANDARD (NEW)	SERVICE LIMIT	
Cylinder block	Warpage of deck surface		0.07 (0.003) max.	0.10 (0.004)	
	Bore diameter F22A1 engine	A	85.010-85.020 (3.3468-3.3472)	85.07 (3.349)	
		B	85.000-85.010 (3.3465-3.3468)		
	H23A1, H22A1 engines	A	87.010-87.020 (3.4256-3.4260)	87.07 (3.428)	
		B	87.000-87.010 (3.4252-3.4256)		
Bore taper		—	0.05 (0.002)		
Reboring limit F22A1 engine		—	0.50 (0.020)		
	H23A1, H22A1 engines	—	0.25 (0.010)		
Piston	Skirt O.D.*1	F22A1 engine	No Letter (A)	84.980-84.990 (3.3457-3.3461)	84.970 (3.3453)
			Letter B	84.970-84.980 (3.3453-3.3457)	84.960 (3.3449)
		H23A1, H22A1 engines	No Letter (A)	86.990-87.003 (3.4248-3.4253)	87.980 (3.4638)
			Letter B	86.980-86.993 (3.4244-3.4249)	87.970 (3.4634)
	Clearance in cylinder	F22A1 engine		0.020-0.040 (0.0008-0.0016)	0.05 (0.002)
		H23A1, H22A1 engines		0.007-0.030 (0.0003-0.0012)	0.04 (0.002)
	Groove width F22A1 engine (for ring)	Top	Oil	1.220-1.230 (0.0480-0.0484)	1.25 (0.049)
			Second	1.220-1.230 (0.0480-0.0484)	1.25 (0.049)
			Oil	2.805-2.820 (0.1104-0.1110)	2.85 (0.112)
		H23A1, H22A1 engines	Top	1.230-1.245 (0.0484-0.0490)	1.265 (0.0498)
			Second	1.230-1.245 (0.0484-0.0490)	1.265 (0.0498)
			Oil	2.805-2.820 (0.1104-0.1110)	2.85 (0.112)
Piston ring	Ring-to-groove clearance	Top	0.035-0.060 (0.0014-0.0024)	0.13 (0.005)	
		Second	0.030-0.055 (0.0012-0.0022)	0.13 (0.005)	
	Ring end gap F22A1 engine	Top	0.20-0.35 (0.008-0.014)	0.60 (0.024)	
		Second	0.40-0.55 (0.016-0.022)	0.70 (0.028)	
	H23A1, H22A1 engines	Oil	0.20-0.70 (0.008-0.028)	0.80 (0.031)	
		Top	0.25-0.35 (0.010-0.014)	0.60 (0.024)	
		Second	0.60-0.75 (0.024-0.030)	0.90 (0.035)	
		Oil	0.20-0.50 (0.008-0.020) *2	0.60 (0.024) *2	
		0.20-0.70 (0.008-0.028) *3	0.80 (0.031) *3		
Piston Pin	O.D.		21.994-22.000 (0.8659-0.8661)	—	
	Pin-to-piston clearance	F22A1 engine	0.012-0.024 (0.0005-0.0009)	—	
		H23A1, H22A1 engines	0.012-0.026 (0.0005-0.0010)	—	
Connecting rod	Pin-to-rod interference		0.013-0.032 (0.0005-0.0013)	—	
	Small end bore diameter		21.968-21.981 (0.8649-0.8654)	—	
	Large end bore diameter	Nominal	51.0 (2.01)	—	
	End play installed on crankshaft		0.15-0.30 (0.006-0.012)	0.40 (0.016)	
	Small end bore-to-large end bore parallelism		0.12 (0.005)/100 max.	0.15 (0.006)/100	
Crankshaft	Main journal diameter	No. 1 and 2 journals	49.976-50.000 (1.9676-1.9685)	—	
		No. 3 journal	49.972-49.996 (1.9674-1.9683)	—	
		No. 4 journal	49.984-50.008 (1.9679-1.9688)	—	
		No. 5 journal	49.988-50.012 (1.9680-1.9690)	—	
		Rod journal diameter		47.976-49.000 (1.8888-1.8898)	—
	Taper		0.005 (0.0002) max.	0.006 (0.0002)	
	Out-of-round		0.005 (0.0002) max.	0.006 (0.0002)	
	End play		0.10-0.35 (0.004-0.014)	0.45 (0.018)	
Total runout		0.03 (0.001) max.	0.04 (0.002)		
Bearings	Main bearing-to-journal oil clearance	No. 1 and 2 journals	0.021-0.045 (0.0008-0.0018)	0.050 (0.0020)	
		No. 3 journal	0.025-0.049 (0.0010-0.0019)	0.055 (0.0022)	
		No. 4 journal	0.013-0.037 (0.0005-0.0015)	0.050 (0.0020)	
		No. 5 journal	0.009-0.033 (0.0004-0.0013)	0.040 (0.0016)	
	Rod bearing-to-journal oil clearance	F22A1 engine	0.021-0.049 (0.0008-0.0020)	0.055 (0.0022)	
		H23A1, H22A1 engines	0.027-0.055 (0.0011-0.0022)	0.060 (0.0024)	

*1: Measured at 21.0 mm (0.83 in) on F22A1 engine and 15.0 mm (0.59 in) on H23A1, H22A1 engines both from bottom of skirt.

*2: TEIKOKU PISTON RING manufactured piston ring.

*3: RIKEN manufactured piston ring.

Standards and Service Limits

Engine Block — Section 7 (cont'd)

	MEASUREMENT		STANDARD (NEW)	SERVICE LIMIT
Balancer shaft	Journal diameter	No. 1 journal (front)	42.722-42.734 (1.6820-1.6824)	42.71 (1.689)
		No. 1 journal (rear)	20.938-20.950 (0.8243-0.8248)	20.92 (0.824)
		No. 2 journals	38.712-38.724 (1.5241-1.5246)	38.70 (1.524)
		No. 3 journals	34.722-34.734 (1.3670-1.3675)	34.71 (1.367)
	Journal taper		0.005 (0.0002)	—
		End play	Front Rear	0.10-0.35 (0.004-0.014) 0.06-0.18 (0.002-0.007)
	Total runout		0.02 (0.001)	0.03 (0.001)
	Oil clearance	No. 1 journal (rear)		0.050-0.075 (0.0020-0.0030)
No. 1 (front) and No. 3 journal			0.066-0.118 (0.0026-0.0046)	0.12 (0.005)
No. 2 journals			0.076-0.128 (0.0030-0.0050)	0.13 (0.005)
Balancer shaft bearing	I.D.	No. 1 journal (front)	42.800-42.820 (1.6850-1.6958)	42.83 (1.686)
		No. 1 journal (rear)	21.000-21.013 (0.8268-0.8273)	21.02 (0.828)
		No. 2 journals	38.800-38.820 (1.5276-1.5283)	38.83 (1.529)
		No. 3 journals	34.800-34.820 (1.3701-1.3709)	34.83 (1.371)

Engine Lubrication — Section 8

	MEASUREMENT		STANDARD (NEW)	SERVICE LIMIT
Engine oil	Capacity ℓ (US qt, Imp qt)	F22A1 engine	4.9 (5.2, 4.3) for engine overhaul 3.8 (4.0, 3.3) for oil change, including filter	
		H23A1 engine	5.4 (5.7, 4.8) for engine overhaul 4.0 (4.2, 3.5) for oil change, including filter	
		H22A1 engine	5.9 (6.2, 5.2) for engine overhaul 4.8 (5.1, 4.2) for oil change, including filter	
Oil pump	Displacement ℓ (US qt, Imp qt)/min @rpm		73.5 (77.7, 64.7) @6,000	
	Inner-to-outer rotor radial clearance		0.02-0.16 (0.001-0.006)	0.20 (0.008)
	Pump body-to-outer rotor radial clearance		0.10-0.19 (0.004-0.007)	0.21 (0.008)
	Pump body-to-rotor axial clearance		0.02-0.07 (0.001-0.003)	0.12 (0.005)
Relief valve	Pressure setting at oil temperature 176°F (80°C)			
	kPa (kg/cm ² , psi) at idle at 3,000 rpm		70 (0.7, 10) min. 350 (3.5, 50) min.	

Cooling — Section 10

	MEASUREMENT		STANDARD (NEW)
Radiator	Engine coolant capacity including engine, heater, cooling line and reservoir ℓ (US qt, Imp qt)	F22A1 engine	M/T: 7.1 (7.5, 6.2) for overhaul 3.5 (3.7, 3.1) for coolant change A/T: 7.0 (7.4, 6.2) for overhaul 3.4 (3.6, 3.0) for coolant change
		H23A1 engine	M/T: 7.4 (7.8, 6.5) for overhaul 3.8 (4.0, 3.3) for coolant change A/T: 7.3 (7.7, 6.4) for overhaul 3.7 (3.9, 3.3) for coolant change
		H22A1 engine	M/T: 7.8 (8.2, 6.9) for overhaul 4.2 (4.4, 3.7) for coolant change
	Reservoir capacity		0.6 (0.6, 0.5)
Radiator cap	Opening pressure kPa (kg/cm ² , psi)		95-125 (0.95-1.25, 13.5-17.8)
Thermostat	Start to open	°F (°C)	169-177 (76-80)
	Fully open	°F (°C)	194 (90)
	Valve lift at fully open		8.0 (0.31) min.
Water pump	Displacement	F22A1 engine	165 (174, 145) @6,000
	ℓ (US qt, Imp qt)/min @rpm	H23A1 engine	159 (168, 140) @6,000
		H22A1 engine	163 (172, 143) @6,000
Radiator fan	ECT switch "ON" temperature	F22A1, H23A1 engines	194-205 (90-96)
		H22A1 engine	198-208 (92-98)
	ECT switch "OFF" temperature	°F (°C)	Subtract 4-13 (1-7) from actual "ON" temperature

Fuel and Emission — Section 11

Unit of length: mm (in)

	MEASUREMENT	STANDARD (NEW)
Fuel pump	Displacement cc (US oz, Imp oz) in 10 seconds	205 (6.93, 7.22) min.
Pressure regulator	Pressure with regulator vacuum hose disconnected kPa (kg/cm ² , psi) F22A1, H23A1 engines H22A1 engine	255-305 (2.55-3.05, 36-43) 230-280 (2.3-2.8, 33-40)
Fuel tank	Capacity ℓ (US gal, Imp gal)	60 (15.9, 13.2)
Engine	Fast idle rpm	1,400
	Idle speed rpm with headlight and cooling fan off	700 ± 50 (M/T: neutral) 700 ± 50 (A/T: N or P position)
	Idle CO %	0.1 max.

Clutch — Section 12

	MEASUREMENT	STANDARD (NEW)	SERVICE LIMIT
Clutch pedal	Pedal height to floor	208 (8.11)	—
	Stroke	135-145 (5.31-5.71)	—
	Pedal play	1.0-7.0 (0.04-0.28)	—
	Disengagement height to floor	94 (3.70) min.	—
Flywheel	Clutch surface runout	0.05 (0.002) max.	0.15 (0.006)
Clutch disc	Rivet head depth	1.3 (0.051) min.	0.2 (0.008)
	Surface runout	0.8 (0.03) max.	1.0 (0.04)
	Thickness	8.4-9.1 (0.331-0.358)	6.0 (0.236)
Clutch cover	Pressure plate warpage	0.03 (0.001) max.	0.15 (0.06)

Manual Transmission — Section 13

	MEASUREMENT	STANDARD (NEW)	SERVICE LIMIT
Transmission oil	Capacity ℓ (US qt, Imp qt)	1.9 (2.0, 1.7) for oil change 2.0 (2.1, 1.8) for overhaul	
Mainshaft	End play	0.10-0.16 (0.0039-0.0063)	Adjust with a shim.
	Diameter of ball bearing contact area	27.977-27.990 (1.1015-1.1020)	27.94 (1.100)
	Diameter of third gear contact area	37.984-38.000 (1.4954-1.4961)	37.93 (1.493)
	Diameter of ball bearing contact area	27.987-28.000 (1.1018-1.1024)	27.94 (1.100)
	Runout	0.02 (0.0008) max.	0.05 (0.002)
Mainshaft 3rd and fourth gears	I.D.	43.009-43.025 (1.6933-1.6939)	43.080 (1.6961)
	End play	0.06-0.21 (0.0024-0.0083)	0.30 (0.012)
	Thickness 3rd gear M2L5, M2S4 M2F4	32.42-32.47 (1.276-1.278)	32.3 (1.272)
		34.92-34.97 (1.375-1.377)	34.8 (1.370)
4th gear M2L5, M2S4 M2F4	30.92-30.97 (1.217-1.219)	30.8 (1.213)	
31.42-31.47 (1.237-1.239)	31.3 (1.232)		
Mainshaft 5th gear	I.D.	43.009-43.025 (1.6933-1.6939)	43.080 (1.6961)
	End play	0.06-0.21 (0.0024-0.0083)	0.30 (0.012)
	Thickness	30.92-30.97 (1.217-1.219)	30.8 (1.213)
Countershaft	End play	0.05-0.40 (0.0019-0.0157)	0.50 (0.02)
	Diameter of needle bearing contact area	38.000-38.015 (1.4961-1.4967)	37.95 (1.494)
	Diameter of ball bearing and needle bearing contact area	24.987-25.000 (0.9837-0.9845)	24.94 (0.982)
	Diameter of low gear contact area	39.984-40.000 (1.5742-1.5748)	39.93 (1.572)
	Runout	0.02 (0.0008) max.	0.05 (0.002)
Countershaft 1st gear	I.D.	46.009-46.025 (1.8114-1.8120)	46.08 (1.814)
	End play	0.04-0.10 (0.002-0.004)	Adjust with a washer.
Countershaft 2nd gear	I.D.	47.009-47.025 (1.8507-1.8514)	47.08 (1.854)
	End play	0.04-0.10 (0.002-0.004)	Adjust with a collar.
	Thickness	28.92-28.97 (1.139-1.141)	28.8 (1.13)

(cont'd)

Standards and Service Limits

Manual Transmission — Section 13 (cont'd)

	MEASUREMENT	STANDARD (NEW)	SERVICE LIMIT
Spacer collar (Countershaft 2nd gear)	I.D.	36.48-36.49 (1.4362-1.4366)	36.50 (1.437)
	O.D.	41.989-42.000 (1.6531-1.6535)	41.94 (1.652)
Space collar (Mainshaft 4th and 5th gear)	Length	29.02-29.04 (1.1425-1.1433)	—
		29.07-29.09 (1.144-1.145)	—
Reverse idler gear	I.D.	31.002-31.012 (1.2205-1.2209)	31.06 (1.223)
	O.D.	37.989-38.000 (1.4956-1.4961)	37.94 (1.494)
Syncro ring	Length	56.45-56.55 (2.222-2.226)	—
		26.03-26.08 (1.0248-1.0268)	—
Reverse idler gear	I.D. Gear-to-reverse gear shaft clearance	20.016-20.043 (0.7880-0.7891) 0.036-0.084 (0.0014-0.0033)	20.09 (0.7909) 0.160 (0.0006)
Syncro ring	Ring-to-gear clearance (ring pushed against gear)	0.85-1.10 (0.034-0.043)	0.40 (0.016)
Dual cone synchro ring	Clearance (ring pushed against gear) Outer synchro ring-to-gear Inner synchro ring-to-gear Outer synchro ring-to-synchro cone	0.95-1.68 (0.037-0.066) 0.5-1.0 (0.02-0.04) 0.5-1.0 (0.02-0.04)	0.6 (0.024) 0.3 (0.01) 0.3 (0.01)
Shift fork	Finger thickness	M2L5, M2S4 M2F4	—
	Fork-to-synchro sleeve clearance	6.2-6.4 (0.244-0.252) 7.4-7.6 (0.291-0.299) 0.35-0.65 (0.014-0.026)	— — 1.0 (0.039)
Reverse shift fork	Pawl groove width	13.0-13.3 (0.51-0.52)	—
	Fork-to-reverse idle gear clearance	0.5-1.1 (0.02-0.43)	1.8 (0.07)
Shift arm	Groove width	7.05-7.25 (0.278-0.2854)	—
	Fork-to-fifth/ reverse shift shaft clearance	7.4-7.7 (0.29-0.30) 0.05-0.35 (0.002-0.014) 0.4-0.8 (0.02-0.03)	— 0.5 (0.02) 1.0 (0.04)
Shift arm	I.D.	15.973-16.000 (0.6289-0.6299)	—
	Shift arm-to-shaft clearance Shift fork diameter at contact area Shift-arm-to-shift fork shaft clearance	0.005-0.059 (0.0002-0.0023) 12.9-13.0 (0.508-0.512) 0.2-0.5 (0.01-0.02)	— — 0.6 (0.2)
Select lever	Pin size of contact area	7.9-8.0 (0.311-0.315)	—
	Select lever-to-shift peice clearance Shaft outer diameter Shift arm cover clearance	0.05-0.25 (0.002-0.010) 15.41-15.68 (0.607-0.617) 0.032-0.102 (0.0013-0.0040)	0.5 (0.020) — —
Shift arm lever	O.D.	15.941-15.968 (0.6276-0.6287)	—
	Transmission housing clearance	0.027-0.139 (0.0011-0.0055)	—
Interlock	Bore diameter	16.00-16.05 (0.630-0.632)	—
	Shift arm lever clearance	0.032-0.109 (0.0013-0.0043)	—

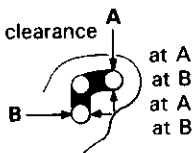
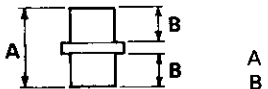

Automatic Transmission — Section 14

Unit of length mm (in)

	MEASUREMENT	STANDARD (NEW)	SERVICE LIMIT	
Transmission fluid	Capacity ℓ (US qt, Imp qt)	6.0 (6.3, 5.3) for overhaul 2.4 (2.5, 2.1) for fluid change		
Hydraulic pressure (F22A1 engine) kPa (kg/cm ² , psi)	Line pressure at 2,000 rpm in [N] or [P] position	800 (8.0, 114) throttle fully-closed 850 (8.5, 121) throttle more than 3/16 open	750 (7.5, 107) throttle more than 3/16 open	
	4th clutch pressure at 2,000 rpm in [D4] position	530 (5.3, 75) throttle fully-closed 850 (8.5, 121) throttle more than 3/16 open	480 (4.8, 68) throttle fully-closed 750 (7.5, 107) throttle more than 3/16 open	
	3rd and 2nd clutch pressure at 2,000 rpm in [D4] position	500 (5.0, 71) throttle fully-closed 850 (8.5, 121) throttle more than 3/16 open	450 (4.5, 64) throttle fully-closed 750 (7.5, 107) throttle more than 3/16 open	
	2nd clutch pressure at 2,000 rpm in [2] position	800-850 (8.0-8.5, 114-121)	750 (7.5, 107)	
	1st and 1st-hold clutch pressure at 2,000 rpm in [1] position	800-850 (8.0-8.5, 114-121)	750 (7.5, 107)	
	Throttle B pressure	Throttle fully closed Throttle fully open	0 (0, 0) 800-850 (8.0-8.5, 114-121)	— 750 (7.5, 107)
	Hydraulic pressure (H23A1 engine) kPa (kg/cm ² , psi)	Line pressure at 2,000 rpm in [N] or [P] position	850 (8.5, 121) throttle fully-closed 900 (9.0, 128) throttle more than 3/16 open	800 (8.0, 114) throttle more than 3/16 open
4rd clutch pressure at 2,000 rpm in [D4] position		530 (5.3, 75) throttle fully-closed 900 (9.0, 128) throttle more than 3/16 open	480 (4.8, 68) throttle fully-closed 800 (8.0, 114) throttle more than 3/16 open	
3rd and 2nd clutch pressure at 2,000 rpm in [D4] position		500 (5.0, 71) throttle fully-closed 900 (9.0, 128) throttle more than 3/16 open	450 (4.5, 64) throttle fully-closed 800 (8.0, 114) throttle more than 3/16 open	
2nd clutch pressure at 2,000 rpm in [2] position		850-900 (8.5-9.0, 121-128)	800 (8.0, 114)	
1st and 1st-hold clutch pressure at 2,000 rpm in [1] position		850-900 (8.5-9.0, 121-128)	800 (8.0, 114)	
Throttle B pressure		Throttle fully closed Throttle fully open	0 (0, 0) 850-900 (8.5-9.0, 121-128)	— 800 (8.0, 114)
Stall speed rpm (Check with car on level ground)		F22A1 engine H23A1 engine	2,350-2,650 2,600-2,900	— —

(cont'd)

Standards and Service Limits

Automatic Transmission — Section 14 (cont'd)

	MEASUREMENT	STANDARD (NEW)	SERVICE LIMIT
Clutch	Clutch initial clearance 1st, 2nd 3rd, 4th	0.80-1.00 (0.031-0.039) 0.65-0.85 (0.026-0.033) 0.4-0.6 (0.016-0.024)	— — —
	Clutch return spring free length 1st, 2nd, 3rd, 4th Clutch disc thickness Clutch plate thickness 1st, 1st-hold 2nd, F22A1 engine H23A1 engine 3rd, 4th	33.5 (1.32) 1.88-2.00 (0.074-0.079) 1.95-2.05 (0.077-0.081) 2.55-2.65 (0.089-0.093) 1.95-2.05 (0.077-0.081) 2.25-2.35 (0.089-0.093)	31.5 (1.24) Until grooves worn out. Discoloration ↑ Discoloration
	Clutch end plate thickness Mark 1 Mark 2 Mark 3 Mark 4 Mark 5 Mark 6 Mark 7 Mark 8 Mark 9	2.05-2.10 (0.081-0.083) 2.15-2.20 (0.085-0.087) 2.25-2.30 (0.089-0.091) 2.35-2.40 (0.093-0.094) 2.45-2.50 (0.096-0.098) 2.55-2.60 (0.100-0.102) 2.65-2.70 (0.104-0.106) 2.75-2.80 (0.108-0.110) 2.85-2.90 (0.112-0.114)	Discoloration ↑ Discoloration
Valve body	Stator shaft needle bearing contact I.D. Torque converter side Oil pump side	27.000-27.021 (1.0630-1.1638) 29.000-29.013 (1.1417-1.1422) 0.03-0.05 (0.001-0.002)	Wear or damage — 0.07 (0.003)
	Oil pump gear side clearance Oil pump gear-to-body clearance Drive Driven	0.210-0.265 (0.0083-0.0104) 0.070-0.125 (0.0028-0.0049) 14.016-14.034 (0.5518-0.5525) 13.980-13.990 (0.5504-0.5508)	— — Wear or damage Wear or damage
Shifting device, parking brake and throttle control system	Reverse shift fork finger thickness	5.90-6.00 (0.232-0.236)	5.40 (0.213)
	Parking brake ratchet pawl Parking brake gear Throttle cam stopper height	— — 17.0-17.1 (0.669-0.673)	} Wear or other defect —
Servo body	Shift fork shaft bore I.D.	14.000-14.010 (0.5512-0.5516)	—
	Shift fork shaft valve bore I.D.	37.000-37.039 (1.4567-1.4582)	37.045 (1.4585)
Regulator valve body	Sealing ring contact I.D.	35.000-35.025 (1.3780-1.3789)	35.05 (1.3799)
Accumulator body	Sealing ring contact I.D.	32.000-32.013 (1.2598-1.2604)	32.050 (1.2618)
Stator shaft	Sealing ring contact I.D.	29.000-29.013 (1.1417-1.1422)	29.050 (1.1437)
Transmission	Diameter of needle bearing contact area		Wear or damage
	On mainshaft of stator shaft	22.984-23.000 (0.9049-0.9055)	↑ Wear or damage
	On mainshaft of 3rd gear collar	45.984-46.000 (1.8104-1.8110)	
	On mainshaft of 4th gear collar	31.984-32.000 (1.2592-1.2598)	
	On countershaft of 1st gear collar	40.984-41.000 (1.6135-1.6142)	
	On countershaft of 4th gear	31.975-31.991 (1.2589-1.2595)	
	On countershaft of parking gear	39.984-40.000 (1.5742-1.5748)	
	On countershaft of reverse gear	35.979-36.000 (1.4165-1.4173)	
	On secondary shaft of 1st gear	31.975-31.991 (1.2589-1.2595)	
	On secondary shaft of 2nd gear	31.975-31.991 (1.2589-1.2595)	
	On reverse idler gear shaft	13.990-14.000 (0.5508-0.5512)	
	Inside diameter		
	Mainshaft 3rd gear	52.000-52.019 (2.0472-2.0480)	
	Mainshaft 4th gear	38.005-38.021 (1.4963-1.4969)	
	Countershaft 1st gear	47.000-47.016 (1.8504-1.8510)	
	Countershaft 4th gear	38.000-38.016 (1.4961-1.4967)	
	Countershaft reverse gear	42.000-42.016 (1.6535-1.6542)	
Countershaft idler gear	48.000-48.016 (1.8898-1.8904)		
Secondary shaft 1st gear	37.000-37.016 (1.4567-1.4573)		
Secondary shaft 2nd gear	37.000-37.016 (1.4567-1.4573)		
Reverse idler gear shaft holder	14.416-1.434 (0.5676-0.5683)		

Automatic Transmission — Section 14

Unit of length: mm (in)

	MEASUREMENT	STANDARD (NEW)				SERVICE LIMIT
		Wire Dia.	O.D.	Free Length	No. of Coils	
Transmission (cont'd)	Mainshaft 3rd gear collar length	19.50-19.55 (0.768-0.770)				Wear or damage wear or damage Wear or damage
	Mainshaft 4th gear collar length	47.50-47.55 (1.870-1.872)				
	Countershaft 1st gear collar length	27.50-27.55 (1.083-1.085)				
	Thrust washer thickness					Wear or damage Wear or damage Wear or damage
	Countershaft 1st gear	1.45-1.50 (0.057-0.059)				
	Countershaft idler gear	3.45-3.55 (0.136-0.140)				
	Countershaft parking gear length	25.030-25.048 (0.9854-0.9861)				
	Secondary shaft 1st gear distance collar length	4.95-5.00 (0.195-0.197)				
	Secondary shaft 2nd gear thrust washer thickness	4.35-4.45 (0.1713-0.1752)				Wear or damage
	Secondary shaft 2nd gear spline washer thickness	4.02-4.05 (0.158-0.159)				—
		4.07-4.10 (0.160-0.161)				—
4.12-4.15 (0.162-0.163)				—		
4.17-4.20 (0.164-0.165)				—		
4.22-4.25 (0.166-0.167)				—		
4.27-4.30 (0.168-0.169)				—		
4.32-4.35 (0.170-0.171)				—		
4.37-4.40 (0.172-0.173)				—		
4.42-4.45 (0.174-0.175)				—		
	MEASUREMENT	STANDARD (NEW)				
Spring	Regulator valve spring A F22A1 engine	1.8 (0.071)	14.7 (0.579)	86.5 (3.406)	16.5	
	H23A1 engine	1.8 (0.071)	14.7 (0.579)	88.6 (3.488)	16.5	
	Regulator valve spring B	1.8 (0.071)	9.6 (0.378)	44.0 (1.732)	12.7	
	Stator reaction spring	4.5 (0.177)	35.4 (1.394)	30.3 (1.193)	1.92	
	Torque converter check valve spring	1.1 (0.043)	8.4 (0.331)	36.4 (1.433)	12.0	
	Relief valve spring	1.0 (0.039)	8.4 (0.331)	39.1 (1.539)	15.1	
	Cooler relief valve spring	1.1 (0.043)	8.4 (0.331)	46.8 (1.843)	17.0	
	2nd orifice control valve spring	0.6 (0.024)	6.6 (0.260)	58.3 (2.295)	15.8	
	Orifice control valve spring	0.8 (0.031)	6.6 (0.260)	52.5 (2.067)	33.0	
	Servo control valve spring	1.0 (0.039)	8.1 (0.319)	52.6 (2.071)	22.4	
	4th exhaust valve spring	0.9 (0.035)	7.1 (0.280)	60.8 (2.394)	28.9	
	Throttle valve B adjusting spring	0.8 (0.031)	6.2 (0.244)	30.0 (1.181)	8.0	
	Throttle valve B spring	1.4 (0.055)	8.5 (0.335)	41.5 (1.634)	10.5	
		1.4 (0.055)	8.5 (0.335)	41.5 (1.634)	11.2	
		1.4 (0.055)	8.5 (0.335)	41.6 (1.638)	12.4	
	1-2 shift valve spring	1.0 (0.039)	8.6 (0.339)	41.3 (1.626)	16.9	
	2-3/3-4 shift valve spring	0.9 (0.035)	7.6 (0.299)	57.0 (2.244)	26.8	
	1st-hold accumulator spring	4.0 (0.157)	25.0 (0.984)	64.7 (2.547)	7.3	
	1st accumulator spring	1.8 (0.071)	16.3 (0.642)	115.4 (4.543)	18.6	
	4th accumulator spring	2.9 (0.114)	22.0 (0.866)	90.1 (3.547)	10.9	
	2nd accumulator spring	3.3 (0.130)	22.0 (0.866)	84.9 (3.343)	11.1	
	3rd accumulator spring	2.6 (0.102)	17.5 (0.689)	104.5 (4.114)	18.0	
	Lock-up shift valve spring	0.9 (0.035)	7.6 (0.229)	73.7 (2.902)	32.0	
Lock-up timing valve spring	0.8 (0.031)	6.6 (0.260)	51.1 (2.012)	14.7		
CPC valve spring	1.4 (0.055)	9.4 (0.370)	33.0 (1.299)	10.5		
Modulator valve spring	1.4 (0.055)	9.4 (0.370)	33.0 (1.299)	10.5		
Lock-up control valve spring	0.7 (0.028)	6.6 (0.260)	38.0 (1.496)	14.1		
3rd kick-down valve spring	1.1 (0.043)	7.6 (0.299)	48.3 (1.902)	23.3		
3-2 kick-down valve spring	1.2 (0.047)	7.1 (0.280)	46.9 (1.846)	20.6		

Standards and Service Limits

Differential (Manual transmission) – Section 15

	MEASUREMENT	STANDARD (NEW)	SERVICE LIMIT
Final driven gear	Backlash	0.085-0.142 (0.0033-0.0056)	0.20 (0.008)
Differential carrier	Pinion shaft contact area I.D.	18.000-18.018 (0.7087-0.7094)	—
	Carrier-to-pinion clearance	0.013-0.047 (0.0005-0.0019)	0.10 (0.004)
	Driveshaft contact area I.D.	28.005-28.025 (1.1026-1.1033)	—
	Carrier-to-driveshaft clearance	0.025-0.066 (0.0010-0.0026)	0.12 (0.005)
Differential	Backlash	0.05-0.15 (0.002-0.006)	Adjust with a shim
	I.D.	18.042-18.066 (0.7103-0.7113)	—
	Pinion gear-to-pinion shaft clearance	0.055-0.095 (0.0022-0.0037)	0.15 (0.006)
Taper roller bearing preload	Starting Torque N-m (kg-cm, lb-in)	1.4-2.6 (14-26, 12-23)	Adjust with a shim

Differential (Automatic transmission) – Section 15

	MEASUREMENT	STANDARD (NEW)	SERVICE LIMIT
Final driven gear	Backlash	0.085-0.142 (0.0033-0.0056)	0.20 (0.008)
Differential carrier	Pinion shaft contact area I.D.	18.000-18.018 (0.7087-0.7094)	—
	Carrier-to-pinion clearance	0.017-0.047 (0.0007-0.0019)	0.10 (0.004)
	Driveshaft contact area I.D.	28.005-28.025 (1.1026-1.1033)	—
	Carrier-to-driveshaft clearance	0.025-0.066 (0.0010-0.0026)	0.12 (0.005)
Differential	Backlash	0.05-0.15 (0.002-0.006)	Adjust with a shim
	I.D.	18.042-18.066 (0.7103-0.7113)	—
	Pinion gear-to-pinion shaft clearance	0.059-0.095 (0.0023-0.0037)	0.12 (0.005)
Taper roller bearing preload	Starting Torque N-m (kg-cm, lb-in)	2.8-4.0 (28-40, 24-35)	Adjust with a shim
	New bearing Reused bearing	2.5-3.7 (25-37, 22-32)	

Steering – Section 17

	MEASUREMENT	STANDARD (NEW)
Steering wheel	Play at steering wheel circumference	0-10 (0-0.4)
	Starting load at steering wheel circumference N (kg, lbs)	30 (3.0, 6.6)
	Engine running When the hydraulic system to the power steering speed sensor is cut off	50 (5.0, 11.0)
Gearbox	Angle of rack-guide-screw loosened from locked position	20 $\begin{smallmatrix} +5^\circ \\ 0 \end{smallmatrix}$
Pump	Pump pressure with valve closed (oil temp./speed: 105°F (40°C) min./idle. Do not run for more than 5 seconds). kPa (kg/cm ² , psi)	7,000-8,000 (70-80, 995-1,138)
Power steering fluid	Recommended fluid	Honda power steering fluid-V
	Fluid capacity ℓ (US qt, Imp qt)	System Reservoir 1.7 (1.80, 1.50) 0.5 (0.53, 0.44)
Power steering belt *	Deflection with 100 N (10 kg, 22 lbs) between pulleys	13.5-16.5 (0.53-0.65) with used belt 9.5-11.5 (0.37-0.45) with new belt
	Belt tension N (kg, lbs) Measured with belt tension gauge	350-500 (35-50, 77-110) with used belt 700-900 (70-90, 154-198) with new belt

* When using a new belt, adjust deflection or tension to new values. Run the engine for 5 minutes then turn it off. Readjust deflection or tension to used belt values.

Suspension – Section 18

		MEASUREMENT	STANDARD (NEW)	SERVICE LIMIT
Wheel alignment (2WS)	Camber	Front	0° 00' ± 1°	—
		Rear	-0° 45' ± 1°	—
	Caster	Front	2° 40' ± 1°	—
		Rear	0 ± 2.0 (0 ± 0.08)	—
	Total toe	Front	IN 2.0 ± 2.0 (0.08 ± 0.08)	—
Front wheel turning angle	Inward wheel	36° 20' ± 2°	—	
	Outward wheel	29° 40'	—	
Wheel alignment (4WS)	Camber	Front	0° 00' ± 1°	—
		Rear	-0° 45' ± 30°	—
	Caster	Front	2° 40' ± 1°	—
		Rear	0 ± 2.0 (0 ± 0.08)	—
	Total toe	Front	IN 2.0 ± 2.0 (0.08 ± 0.08)	—
		Rear	36° 20' ± 2°	—
	Wheel turning angle	Inward wheel	6° 00' ± 1°	—
Outward wheel		29° 20'	—	
		6° 20'	—	
Wheel	Rim runout (Aluminum wheel)	Axial	0-0.7 (0-0.03)	2.0 (0.08)
		Radial	0-0.7 (0-0.03)	1.5 (0.06)
	Rim runout (Steel wheel)	Axial	0-1.0 (0-0.04)	2.0 (0.08)
		Radial	0-1.0 (0-0.04)	1.5 (0.06)
Wheel bearing	End play	Front	0-0.05 (0.002)	—
		Rear	0-0.05 (0.002)	—

Brakes – Section 19

		MEASUREMENT	STANDARD (NEW)	SERVICE LIMIT
Parking brake lever		Play in stroke at 200 N (20 kg, 44 lbs) lever force	To be locked when pulled 6-10 notches	—
Foot brake pedal		Pedal height (with floor mat removed)	M/T 165 (6.5) min. A/T 186 (7.3) min.	—
		Free play	1-5 (1/16-13/64)	—
Master cylinder		Piston-to-pushrod clearance	Cars without ABS 0-0.4 (0-0.02) Cars with ABS 0-0.2 (0-0.01)	—
Disc brake	Disc thickness	Front	23.0 (0.09)	21.0 (0.83)
		Rear	10.0 (0.39)	8.0 (0.31)
	Disc runout	Front	—	0.10 (0.004)
		Rear	—	0.10 (0.004)
	Disc parallelism	Front and rear	—	0.015 (0.0006)
	Pad thickness	Front	H22A1, H23A1 engine 12.5 (0.49)	1.6 (0.06)
Rear		H22A1 engine 11.0 (0.43)	1.6 (0.06)	
			9.0 (0.35)	1.6 (0.06)

Standards and Service Limits

Air Conditioning — Section 22

	MEASUREMENT	STANDARD (NEW)
Air conditioning system	Lubricant capacity cc (fl oz) Condenser Evaporator Line or hose Reservoir	10 (1/3) 30 (1) 10 (1/3) 10 (1/3)
Compressor	Lubricant capacity cc (fl oz) Field coil resistance at 68°F (20°C) Ω Pulley-to-pressure plate clearance	130-150 (4 1/3 - 5) 3.05-3.35 0.35-0.65 (0.014-0.026)
Compressor belt*	Deflection with 100 N (10 kg, 22 lbs) between pulleys	10.0-12.0 (0.39-0.47) with used belt 4.5-7.0 (0.18-0.28) with new belt
	Belt tension N (kg, lbs) Measured with belt tension gauge	450-600 (45-60, 99-132) with used belt 950-1,150 (95-115, 209-254) with new belt

* When using a new belt, adjust deflection or tension to new values. Run the engine for 5 minutes then turn it off. Readjust deflection or tension to used belt values.

Electrical — Section 23

	MEASUREMENT	STANDARD (NEW)	SERVICE LIMIT
Ignition coil	Rated voltage V Primary winding resistance at 68 °F (20°C) Ω Secondary winding resistance at 68 °F (20°C) kΩ	12 0.6-0.8 14-22	
Spark Plug	Type Gap	See Section 23 1.0-1.1 (0.39-0.43)	
Ignition timing	At idling ° BTDC	15° ± 2° (Red) BTDC	
Alternator belt*	Deflection with 100 N (10 kg, 22 lbs) between pulleys	10.5-12.5 (0.42-0.51) with used belt 8.0-10.0 (0.32-0.40) with new belt	
	Belt tension N (kg, lbs) Measured with belt tension gauge	300-450 (30-45, 66-99) with used belt 550-750 (55-75, 121-165) with new belt	
	MEASUREMENT	STANDARD (NEW)	SERVICE LIMIT
Alternator (NIPPONDENSO)	Output 13.5 V at hot A Coil resistance (rotor) Ω Slip ring O.D. Brush length Brush spring tension g (oz)	80/90 2.7-3.1 14.2-14.4 (0.56-0.57) 10.5 (0.41) 300-360 (10.6-12.7)	— — 12.8 (0.50) 1.5 (0.06) —
Starter motor (MITSUBA 1.4 kW)	Type Mica depth Commutator runout Commutator O.D. Brush length Brush spring tension (new) N (kg, lbs)	Spar gear reduction, Permanent magnet 0.4-0.5 (0.016-0.020) 0-0.02 (0-0.0008) 28.0-28.1 (1.102-1.106) 15.8-16.2 (0.62-0.64) 16.0-18.0 (1.60-1.80, 3.53-3.93)	0.15 (0.006) 0.05 (0.002) 27.5 (1.083) 10.0 (0.39) —
Starter motor (MITSUBA 1.6 kW)	Type Mica depth Commutator runout Commutator O.D. Brush length Brush spring tension (new) N (kg, lbs)	Spar gear reduction, Permanent magnet 0.4-0.5 (0.016-0.020) 0-0.02 (0-0.0008) 28.0-28.1 (1.102-1.106) 15.8-16.2 (0.62-0.64) 16.0-18.0 (1.60-1.80, 3.53-3.93)	0.15 (0.006) 0.05 (0.002) 27.5 (1.083) 10.0 (0.39) —

* When using a new belt, adjust deflection or tension to new values. Run the engine for 5 minutes then turn it off. Readjust deflection or tension to used belt and values.

Design Specifications

	ITEM	METRIC	ENGLISH	NOTES	
Dimensions	Overall Length	4,440 mm	174.8 in		
	Overall Width	1,765 mm	69.5 in		
	Overall Height	1,290 mm	50.8 in		
	Wheelbase	2,550 mm	100.4 in		
	Track F/R	1,525/1,515 mm	60.0/59.6 in		
	Ground Clearance	145 mm	5.7 in		
	Seating Capacity	Four			
WEIGHT (USA)	Gross Vehicle Weight Rating (GVWR)	—	3,790 lbs		
WEIGHT (CANADA)	Gross Vehicle Weight Rating (GVWR)	1,720 kg	—		
ENGINE	Type	F22A1 engine	Water-cooled, 4-stroke SOHC gasoline engine		
		H23A1 engine	Water-cooled, 4-stroke DOHC gasoline engine		
		H22A1 engine	Water-cooled, 4-stroke DOHC VTEC gasoline engine		
	Cylinder Arrangement		Inline 4-cylinder, transverse		
	Bore and Stroke	F22A1 engine	85.0 × 95.0 mm	3.35 × 3.74 in	
		H23A1 engine	87.0 × 95.0 mm	3.42 × 3.74 in	
		H22A1 engine	87.0 × 90.7 mm	3.43 × 3.57 in	
	Displacement	F22A1 engine	2,156 cm ³ (cc)	132 cu-in	
		H23A1 engine	2,259 cm ³ (cc)	138 cu-in	
		H22A1 engine	2,157 cm ³ (cc)	132 cu-in	
	Compression Ratio	F22A1 engine	8.8 : 1		
		H23A1 engine	9.8 : 1		
		H22A1 engine	10.0 : 1		
	Valve Train	F22A1 engine	Belt driven, SOHC 4-valve per cylinder		
	H23A1 engine	Belt driven, DOHC 4-valve per cylinder			
	H22A1 engine	Belt drive, DOHC 4-valve per cylinder VTEC			
Lubrication System		Forced and wet sump, trochoid pump			
Fuel Required	F22A1 engine	UNLEADED grade gasoline with 86 Pump Octane Number or higher			
	H23A1, H22A1 engines	Premium UNLEADED grade gasoline with 91 Pump Octane Number or higher			
STARTER	Makes/Type	MITSUBA/Spur gear reduction, permanent magnet			
	Normal Output	1.4 kW, 1.6 kW			
	Nominal Voltage	12 V			
	Hour Rating	30 seconds			
	Direction of Rotation	Counterclockwise as viewed from gear end			
	Weight	3.7 kg	8.2 lbs		
CLUTCH	Clutch Type	M/T	Single plates dry, diaphragm spring		
		A/T	Torque converter		
	Clutch Facing Area	M/T	203 cm ²	31 sq-in	
TRANSMISSION	Transmission Type	M/T	Synchronized 5-speed forward, 1 reverse		
		A/T	Electronically controlled		
	Primary Reduction		4-speed automatic, 1 reverse		
			Direct 1 : 1		
	Manual Transmission	Engine type	F22A1	H23A1	H22A1
	Gear Ratio	1st	3.307	3.307	3.307
		2nd	1.809	1.857	1.950
		3rd	1.230	1.320	1.360
4th		0.903	1.034	1.071	
5th		0.705	0.812	0.870	
	Reverse	3.000	3.000	3.000	
Final Reduction	Gear type	Single helical gear			
	Gear ratio	4.062	4.266	4.266	

(cont'd)

Design Specifications

(cont'd)

	ITEM	METRIC	ENGLISH	NOTES	
TRANSMISSION (cont'd)	Automatic Engine type	F22A1	H23A1		
	Gear Ratio	1st	2.705	2.705	
		2nd	1.482	1.535	
		3rd	1.028	1.057	
		4th	0.707	0.750	
5th		—	—		
	Reverse	2.047	2.047		
	Final Reduction	Gear type Gear ratio	Single helical gear 4.285	4.428	
AIR CONDITIONING	Cooling Capacity	3,700 Kcal/h	14,682 BTU/h		
	Conditions:				
	Compressor Speed	1,800 rpm			
	Outside Air Temperature	27 °C	81 °F		
	Outside Air Humidity	50 %			
	Condenser Air Temperature	35 °C	95 °F		
	Condenser Air Velocity	2.5 m/sec	8.2 ft/sec		
	Blower Capacity	460 m ³ /h	16,247 cu-ft/h		
	Compressor	Type/Makes No. of Cylinder Capacity Max. Speed Lubricant Capacity	Scrool type/SANDEN — 85.7 cc/rev 5.23 cu-in/rev 10,000 rpm 130 cc 4 1/3 fl oz		SP-10
	Condenser	Type	Corrugated fin type		
Evaporator	Type	Corrugated fin type			
Blower	Type Motor Input Speed Control Max. Capacity	Sirocco fan 220 W/12 V 4-speed 460 m ³ /h 16,247 cu-ft/h			
Temp. Control		Air-mix type			
Comp. Clutch	Type Power Consumption	Dry, single plate, poly-V-belt drive 42 W max./12 V			
Refrigerant	Type Quantity	R-134a 650- [±] 80 g 18.4- [±] 1.80 oz			
STEERING SYSTEM	Type	Power assisted, rack and pinion			
	Overall Ratio Turns, Lock-to-Lock Steering Wheel Dia.	2WS: 15.86, 4WS: 15.1 2WS: 2.91, 4WS: 2.77 380 mm 15.0 in			
SUSPENSION	Type, Front	Independent double wishbone, coil spring with stabilizer			
	Type, Rear	Independent double wishbone, coil spring with stabilizer			
	Shock Absorber, Front and Rear	Telescopic, hydraulic nitrogen gas-filled			

	ITEM	METRIC	ENGLISH	NOTES
WHEEL ALIGNMENT	Camber Front Rear Caster Total Toe Front Rear	0° 00' - 1° 45' 2° 40'	0 in In 0.08 in	
BRAKE SYSTEM	Type, Front Rear Pad and Lining Surface Area: Front Rear Parking Brake Kind and Type	Power-assisted self-adjusting ventilated disc Power-assisted self-adjusting solid disc 58.0 cm ² x 2 27.0 cm ² x 2	8.99 sq-in x 2 4.19 sq-in x 2 Mechanical actuating, rear two wheel brakes	
TIRE	Size *1: S *2: Except S	185/70 R 14 87 H *1 205/55 R 15 87 V *2 T125/70 D 15 (Spare tire) *1 T135/80 D 15 (Spare tire) *2		
ELECTRICAL	Battery Starter Alternator Fuses In Under-dash Fuse/Relay Box In Under-hood Fuse/Relay Box Headlights High Low Front Turn Signal Lights Front Parking Lights Rear Turn Signal Lights Brake/Taillights High Mount Brake Light Side Marker Lights Front Rear Back-up Lights License Plate Lights Interior Lights Trunk Lights Gauge Lights Indicator Lights Warning Lights Illumination and Pilot Lights Heater Illumination Lihgts	12 V-55AH/5HR 12 V-1.4 kW, 12 V-1.6 kW 12 V-90 A, 80 A 7.5 A, 10 A, 15 A, 20 A, 30 A 7.5 A, 10 A, 15 A, 20 A, 40 A, 50 A, 60 A, 100 A 12 V-65 W 12 V-55 W 12 V-32 CP 12 V-5 W 12 V-45 CP 12 V-43/3 CP 12 V-21 CP 12 V-3 CP 12 V-3 CP 12 V-32 W 12 V-8 W 12 V-8 W 12 V-3.4 W 12 V-3.0 W, 1.4 W 12 V-1.12 W, 1.4 W, 3.0 W, 3.2 W 12V-1.4 W 12 V-1.4 W, 1.12 W, 0.84 W, LED 12 V-1.4 W		

Body Specifications

Unit: mm (in)

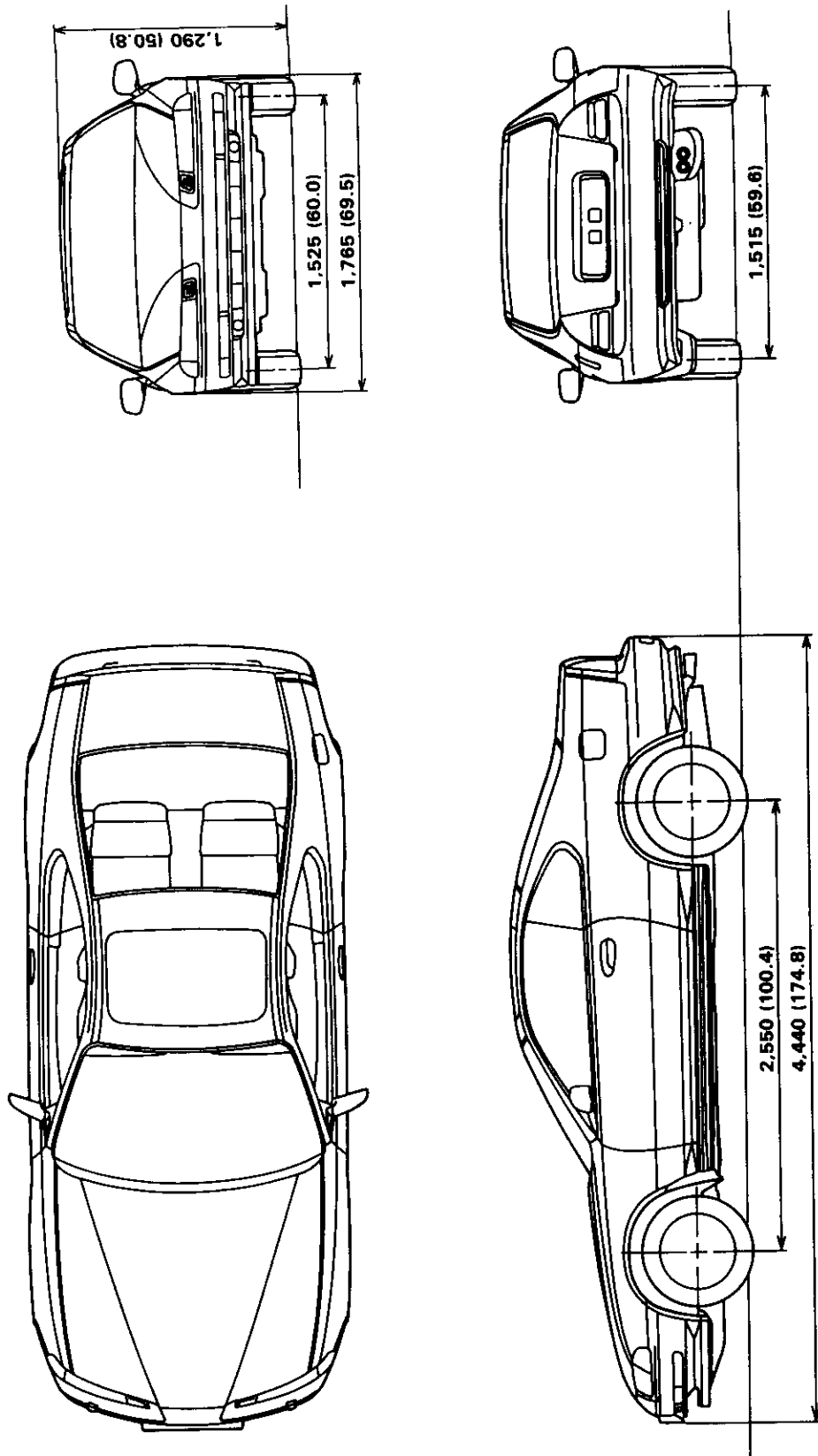

Maintenance

Lubrication Points	4-2
Maintenance Schedule	4-4



Lubrication Points

For details of lubrication points and types of lubricants to be applied, refer to the Illustrated Index and various work procedures (such as Assembly/Reassembly, Replacement, Overhaul, Installation, etc.) contained in each section.

No.	LUBRICATION POINTS	LUBRICANT
1	Engine	API Service Grade: Use "Energy Conserving II" SG grade oil. F22A1, H23A1 engine: 5 W-30 preferred. H22A1 engine: 10 W-30 preferred. SAE Viscosity: See chart below.
2	Transmission Manual Automatic	API Service Grade: SF or SG SAE viscosity: 10 W-30 or 10 W-40 Honda Premium Formula Automatic Transmission Fluid or an equivalent DEXRON® II Automatic transmission fluid
3	Brake Line	Brake fluid DOT3 or DOT4
4	Clutch Line	Brake fluid DOT3 or DOT4
5	Power steering gearbox	Steering grease P/N 08733-B070E
6	Shift lever pivots (Manual transmission)	Grease with molybdenum disulfide
7	Release fork (Manual transmission)	Multi-purpose grease
8	Steering boots	
9	Steering ball joints	
10	Select lever (Automatic transmission)	
11	Pedal linkage	
12	Intermediate shaft	
13	Brake master cylinder pushrod	
14	Trunk hinges and latch	
15	Door hinges upper/lower and latches	
16	Door opening detents	
17	Fuel fill lid	
18	Engine hood hinges and engine hood latch	
19	Clutch master cylinder pushrod	
20	Throttle cable end	
21	Caliper Piston seal, Dust seal, Caliper pin, Piston	Silicone grease
22	Shift and select cable ends	
23	Power steering system	Honda power steering fluid-V
24	A/C Compressor	Compressor oil SP10 P/N 38899-P13-003

Select the oil for your car according to this chart:

F22A1, H23A1 engine

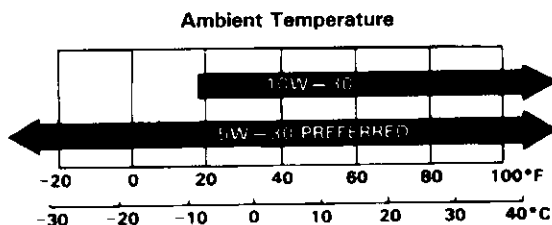

An oil with a viscosity of 5 W-30 is preferred for improved fuel economy and year-round protection in the car. You may use a 10 W-30 oil if the climate in your area is limited to the temperature range shown on the chart.

H22A1 engine

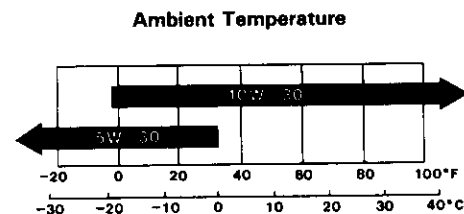

An oil with a viscosity of 10 W-30 is preferred for improved fuel economy and year-round protection in the car. You may use a 5 W-30 oil if the climate in your area is within the temperature range shown on the chart.

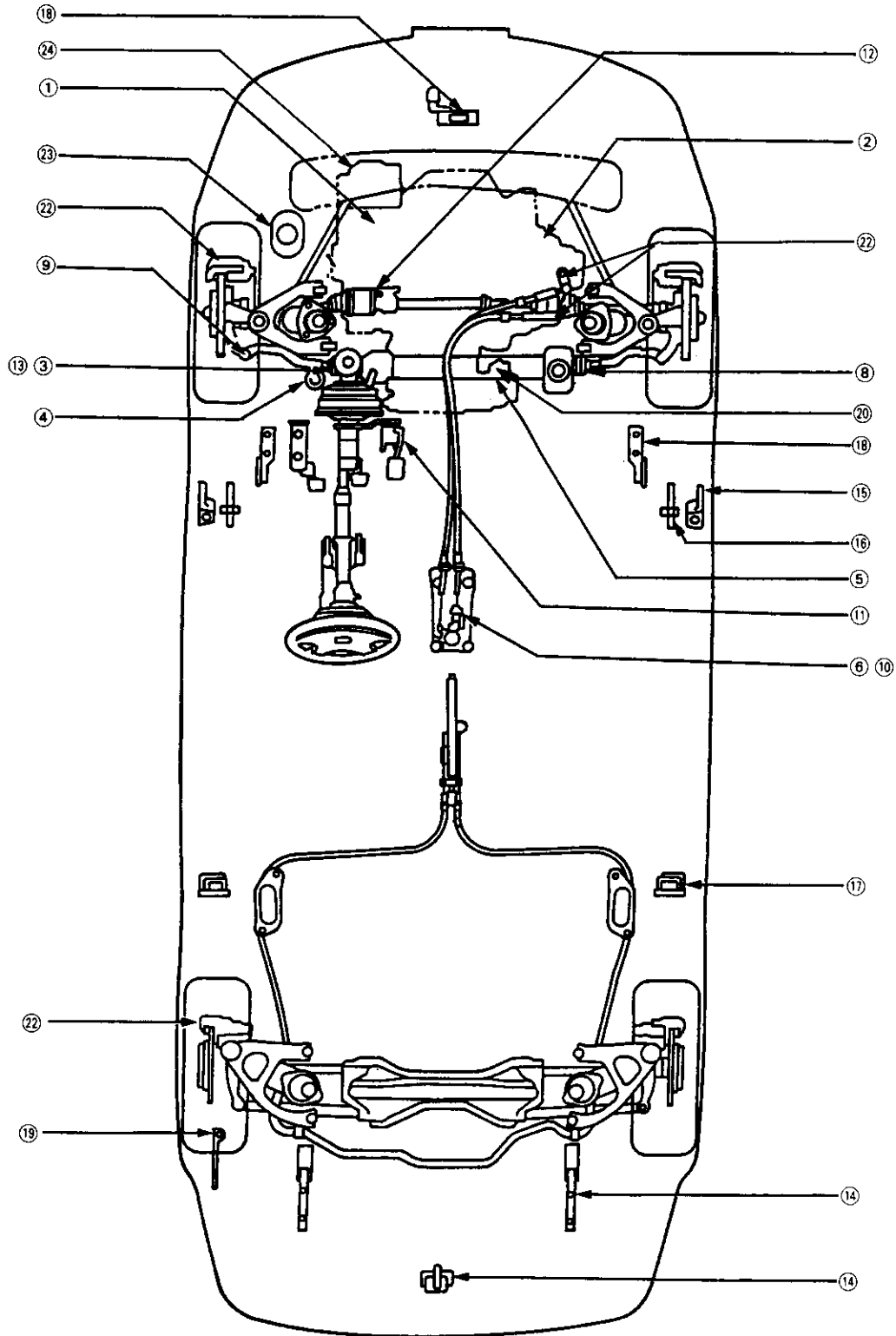

Maintenance Schedule

R—Replace I—Inspect After inspection, clean, adjust, repair or replace if necessary.

Maintenance item	Service at the interval listed x 1,000 miles (or km) or after that number of months, whichever comes first.																NOTE	SEC and PAGE														
	x 1,000 miles		7.5		15		22.5		30		37.5		45		52.5				60		67.5		75		82.5		90		97.5		105	
	x 1,000 km		12		24		36		48		60		72		84				96		108		120		132		144		156		168	
months	6		12		18		24		30		36		42		48		54		60		66		72		78		84					
Engine and Transmission																																
<input type="checkbox"/> Air cleaner element																															Manual transmission: 700 ± 50 rpm Automatic transmission: 700 ± 50 rpm (in N or P position)	11-133
Idle speed																																11-111
Positive crankcase ventilation valve																															If clicking sound is heard as you pinch the hose between the PCV valve and intake manifold, valve is OK.	11-159
Valve clearance (cold)																															Intake: 0.23–0.28 mm (0.009–0.011 in) ^{1,5} Exhaust: 0.27–0.32 mm (0.011–0.013 in) ^{1,5} Intake: 0.07–0.11 mm (0.003–0.004 in) ^{1,6} Exhaust: 0.15–0.19 mm (0.006–0.007 in) ^{1,6} Intake: 0.15–0.19 mm (0.006–0.007 in) ^{1,7} Exhaust: 0.17–0.21 mm (0.007–0.008 in) ^{1,7} Measured when cold.	6-34 ⁵ 6-68 ⁶ 6-115 ⁷
Fuel filter																															The rubber fuel hoses need periodic replacement since they are subject to cracks and deterioration during a long period of use.	11-123
Fuel pipes, hoses, and connections																															Check fuel lines for loose connections, cracks and deteriorations. Retighten loose connections and replace any damaged parts.	11-6
Spark plugs																															NGK: ZFR5F-11 ⁵ , NIPPONDENSO: KJ16CR-L11 ⁵ NGK: ZFR6F-11 ⁶ , NIPPONDENSO: KJ20CR-L11 ⁶ NGK: PZER6F-11 ⁷ , NIPPONDENSO: PKJ20CR-L11 ⁷ Gap: 1.0–1.1 mm (0.039–0.043 in)	23-101
Distributor ignition cap and rotor																															Maximum resistance 25 kΩ	23-95
Ignition wires																																23-99
Engine oil																															Capacity for change with filter: 3.8 l (4.0 US qt, 3.3 Imp qt) ⁵ 4.3 l (4.5 US qt, 3.8 Imp qt) ⁶ 4.8 l (5.1 US qt, 4.2 Imp qt) ^{1,7}	8-5

*: Check oil and coolant level at each fuel stop.
: Under severe driving conditions, service these items more often.
¹: For cars sold in California, this service is recommended only; other areas, it is required.
²: Replace every 6 years or 60,000 miles (96,000 km), whichever comes first.
⁵: F22A1 engine
⁶: H23A1 engine
⁷: H22A1 engine



R—Replace I—Inspect After inspection, clean, adjust, repair or replace if necessary.

Maintenance item	Service at the interval listed x 1,000 miles (or km) or after that number of months, whichever comes first.																NOTE	SEC and PAGE					
	x 1,000 miles		x 1,000 km		months		7.5	15	22.5	30	37.5	45	52.5	60	67.5	75			82.5	90	97.5	105	
	7.5	15	22.5	30	37.5	45	52.5	60	67.5	75	82.5	90	97.5	105									
Engine and Transmission																							
<input type="checkbox"/> Engine oil filter	<input type="checkbox"/>	<input type="checkbox"/>	<input type="checkbox"/>	<input type="checkbox"/>	<input type="checkbox"/>	<input type="checkbox"/>	<input type="checkbox"/>	<input type="checkbox"/>	<input type="checkbox"/>	<input type="checkbox"/>	<input type="checkbox"/>	<input type="checkbox"/>	<input type="checkbox"/>	<input type="checkbox"/>	<input type="checkbox"/>	<input type="checkbox"/>	<input type="checkbox"/>	<input type="checkbox"/>	<input type="checkbox"/>	<input type="checkbox"/>		8-6	
Alternator drive belt							I															10.5–12.5 mm (0.42–0.51 in) @ 100 N (10 kg, 22 lbs) tension	23-113
Cooling system hoses and connections							I ¹																10-2, 3
• Engine coolant																						Capacity for change: Manual transmission: 3.5 ℓ (3.7 US qt, 3.1 Imp qt) ^{1,5} 3.8 ℓ (4.0 US qt, 3.3 Imp qt) ^{1,6} 4.0 ℓ (4.2 US qt, 3.5 Imp qt) ^{1,7} Automatic transmission: 3.4 ℓ (3.6 US qt, 3.0 Imp qt) ^{1,5} 3.7 ℓ (3.9 US qt, 3.3 Imp qt) ^{1,6} Check specific gravity for freezing point.	10-6
Timing belt and timing balancer belt																							6-29 ^{1,5} 6-63 ^{1,6} 6-109 ^{1,7}
Water pump																							10-12
Three way catalytic converter heat shield																							11-151
Exhaust pipe (before catalytic converter)							I ¹																9-7
Exhaust pipe and muffler (after catalytic converter)							I																9-7
<input type="checkbox"/> Manual transmission oil							<input type="checkbox"/>															1.9 ℓ (2.0 US qt, 1.7 Imp qt) for change	13-3
<input type="checkbox"/> Automatic transmission fluid							<input type="checkbox"/>															2.4 ℓ (2.5 US qt, 2.1 Imp qt) for change HONDA Premium Formula ATF or DEXRON® II ATF	14-72
Brakes																							
Front brake pad	I	I	I	I	I	I	I	I	I	I	I	I	I	I	I	I	I	I	I	I	I	Min. thickness: 1.6 mm (0.06 in)	19-7
<input type="checkbox"/> Front brake discs and calipers	<input type="checkbox"/>	<input type="checkbox"/>	<input type="checkbox"/>	<input type="checkbox"/>	<input type="checkbox"/>	<input type="checkbox"/>	<input type="checkbox"/>	<input type="checkbox"/>	<input type="checkbox"/>	<input type="checkbox"/>	<input type="checkbox"/>	<input type="checkbox"/>	<input type="checkbox"/>	<input type="checkbox"/>	<input type="checkbox"/>	<input type="checkbox"/>	<input type="checkbox"/>	<input type="checkbox"/>	<input type="checkbox"/>	<input type="checkbox"/>	<input type="checkbox"/>	Min. thickness: 19 mm (0.75 in) ^{1,5, 1,6} : 21 mm (0.83 in) ^{1,7}	19-11
<input type="checkbox"/> Rear brake discs, calipers and pads	<input type="checkbox"/>	<input type="checkbox"/>	<input type="checkbox"/>	<input type="checkbox"/>	<input type="checkbox"/>	<input type="checkbox"/>	<input type="checkbox"/>	<input type="checkbox"/>	<input type="checkbox"/>	<input type="checkbox"/>	<input type="checkbox"/>	<input type="checkbox"/>	<input type="checkbox"/>	<input type="checkbox"/>	<input type="checkbox"/>	<input type="checkbox"/>	<input type="checkbox"/>	<input type="checkbox"/>	<input type="checkbox"/>	<input type="checkbox"/>	<input type="checkbox"/>	Min. thickness: Discs 8.0 mm (0.31 in) : Pads 1.6 mm (0.06 in)	19-20

•: Check oil and coolant level at each fuel stop.
 □: Under severe driving conditions, service these items more often.
¹: For cars sold in California, this service is recommended only; other areas, it is required.
²: Thereafter, replace every 2 years or 30,000 miles (48,000 km), whichever comes first.
³: This service is recommended only.
⁴: F22A1 engine
⁵: H23A1 engine
⁶: H22A1 engine
⁷: H22A1 engine

Engine

Construction and Function	
(H22A1 engine)	5-1
Engine Removal/Installation	5-17
Cylinder Head/Valve Train	6-1
Engine Block	7-1
Engine Lubrication	8-1
Intake Manifold/Exhaust System	9-1
Cooling	10-1



Construction and Function (H22A1 engine)

Outline

Description 5-2

VTEC

Outline 5-4

Mechanism 5-6

Control System 5-7

Cylinder Head

Outline 5-9

Camshafts 5-10

Valves and Valve Springs 5-11

Belt Tensioner

Outline 5-12

Auto-Tensioner 5-13

Cylinder Block 5-14

Oil Flow 5-15



Outline

Description

The new H22A1 engine is an in-line 4-cylinder DOHC design displacing 2,157 cm³ (131.6 cu-in). It is water cooled and equipped with a center plug type pent-roof combustion chamber. It is specified to use premium unleaded fuel and uses a PGM-FI (Sequential Multiport Fuel Injection) system. This engine incorporates a mechanism called Honda Variable Valve Timing and Valve Lift Electronic Control (VTEC) System.

This system allows the timing and lift of the intake and exhaust valves to be changed simultaneously. The engine also includes a electronically-controlled intake manifold system that varies the volume of the intake chamber.

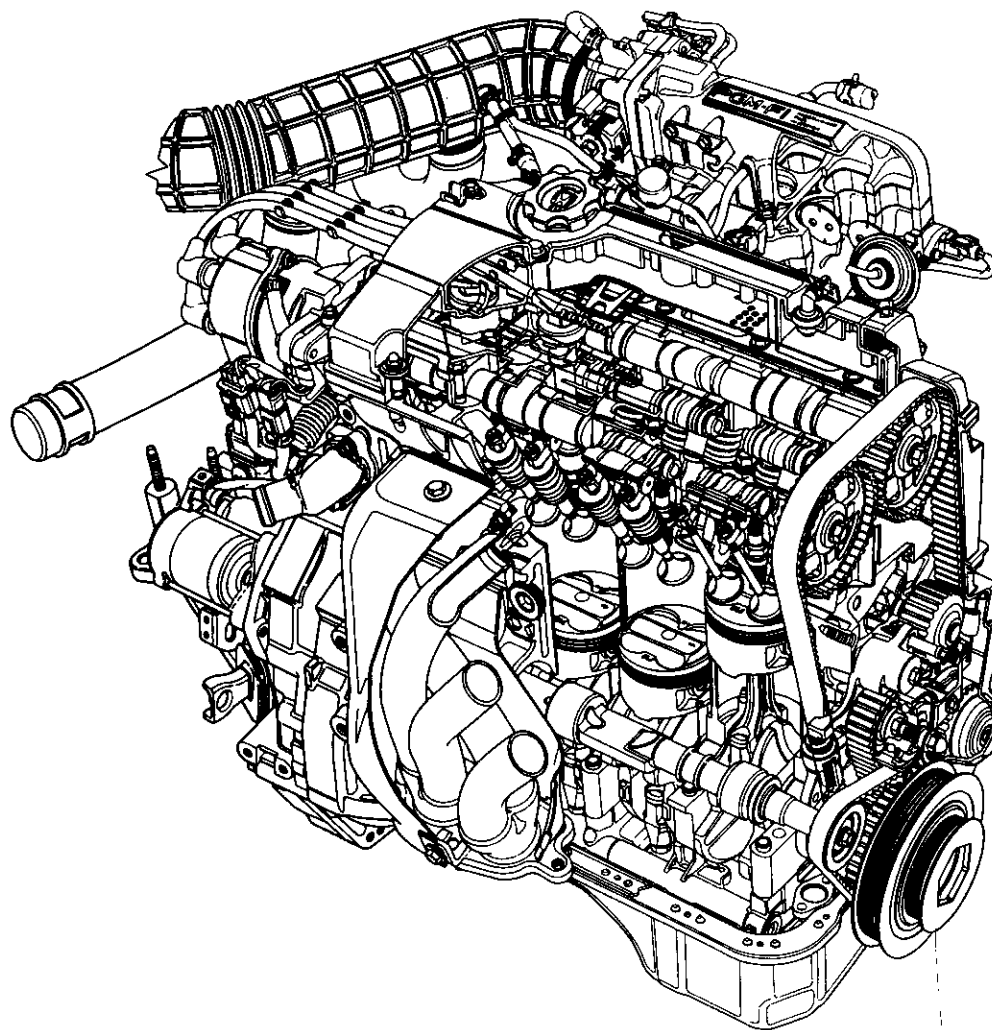



Major Specifications

Type	Water cooled 4-stroke, In-line 4-cylinder gasoline engine
Displacement	2,157 cm ³ (131.6 cu-in)
Bore x Stroke	87.0 x 90.7 mm (3.43 x 3.57 in)
Compression Ratio	10.0 : 1
Cam, Valve Mechanism	Dual over-head camshaft, VTEC
Valve Train	Belt Driven
Fuel Supply System	Sequential Multiport Fuel Injection (SFI)

Main Features:

- The cylinder head is made of aluminum alloy, a center plug type, pentroof-shaped combustion chamber is used, and the 4-valve system uses 2 intake valves and 2 exhaust valves.
- The camshafts and the valve train are driven with the timing belt, and the two balancer shafts are driven by the timing balancer belt. Belt tension is automatically adjusted.
- The cylinder block is made of aluminum alloy using fiber reinforced metal (FRM) sleeves.
- The crankshaft is made by forging, the mainshaft is supported at five points and has eight balancer weights.
- The balancer shafts employ a gear-type reverse mechanism to reduce secondary engine vibration.
- The intake manifold is made of aluminum alloy, and the heat riser is used for heating the air/fuel mixture.
- The exhaust manifold is made of stainless steel.
- The electronic fuel injection system is of a sequential multiport fuel injection type and injects fuel into all four cylinders, the throttle body is of a one-barrel side-draft type.
- The ignition system is a fully-transistorized, contactless type. The spark advance is electronic.
- The air cleaner is equipped with a resonator.
- The radiator is of a corrugated type, and the cooling fan is electrically powered.

VTEC

Outline

The engine is equipped with multiple cam lobes per cylinder, providing one valve timing and valve lift profile at low speed and a different profile at high speed. Switch-over from one profile to the other is controlled electronically, and is selected by monitoring current engine speed and load.

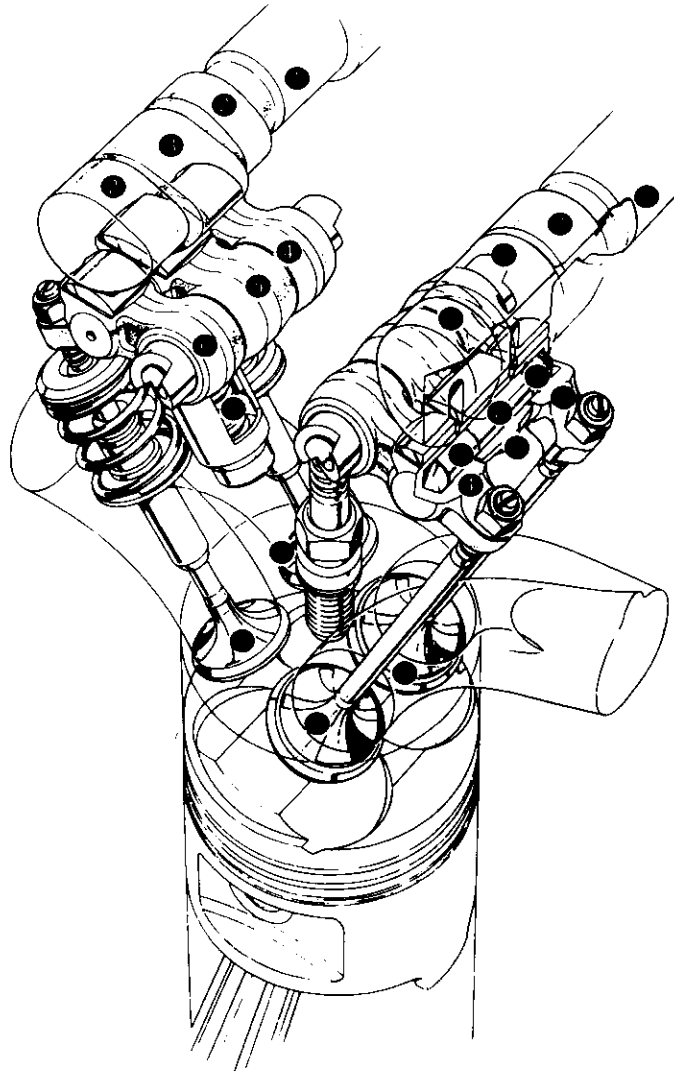

- CAMSHAFT
- CAM LOBES FOR LOW RPM
- CAM LOBES FOR HIGH RPM
- PRIMARY ROCKER ARM
- MID ROCKER ARM
- SECONDARY ROCKER ARM
- HYDRAULIC PISTON (A)
- HYDRAULIC PISTON (B)
- STOPPER PISTON
- LOST MOTION ASSEMBLY
- EXHAUST VALVE
- INTAKE VALVE



In general, it would be ideal if the high rpm performance of a racing engine and the low rpm performance of a standard passenger car engine could be combined in a single engine. This would result in a maximum performance engine with a wide power band. Two of the major differences between racing engines and standard engines are the timing of the intake/exhaust valves and the degree of valve lift. Racing engines have longer intake/exhaust timing and a higher valve lift than standard engines. The Honda Variable Valve Timing and Valve Lift Electronic Control System takes this into account. When valve actuation is set for low rpm timing and lift, low rpm torque is better than in a standard engine. When valve actuation is then switched for high rpm timing and lift, output improves to the level given by a racing engine. Until now, few variable valve timing systems have been commercialized. In those that have, only the time that both valves are open (intake/exhaust overlap) could be changed. Honda's system is the first in the world in which both the valve timing and the degree of valve lift can be changed as needed, making it the most advanced valve train mechanism available.

	Racing Engine	VTEC Engine	Standard Engine
Valve Timing (exhaust/intake) Valve Lift			
Max. Power	○	○	
Low rpm Torque		○	○
Idling Stability		○	○

*TDC = Top Dead Center *BDC = Bottom Dead Center
○ = Optimum Characteristic

The engine is equipped with two valve timing and valve lift settings which change according to driving conditions.

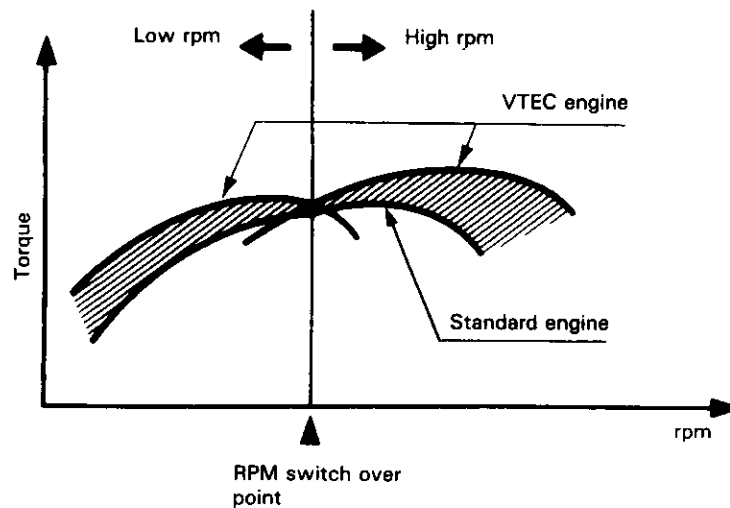

VTEC

Mechanism

At Low rpm:

As shown, the primary and secondary rocker arms are not connected to the mid rocker arm but are driven separately by cam lobes A and B at different timing and lift. Although the mid rocker arm is following the center cam lobe with the lost-motion assembly, it has no effect on the opening and closing of the valves in the low rpm range.

At Low rpm:

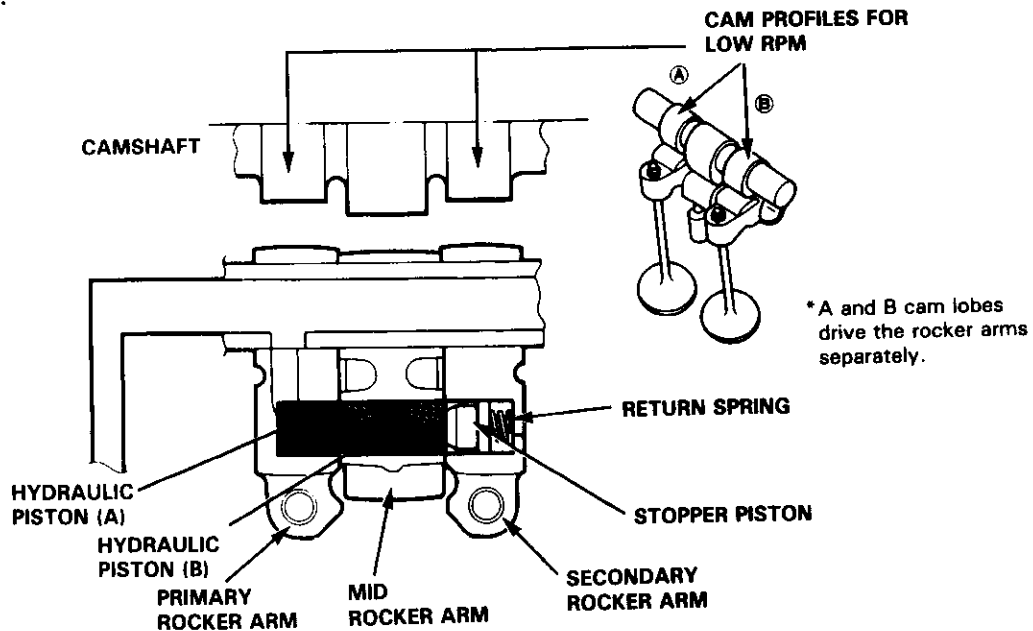

At High rpm:

When driving at high rpm, piston (A) moves in the direction shown by the arrow in the figure below. As a result, the primary, secondary, and mid rocker arms are linked by 2 hydraulic pistons (like a skewer) and the 3 rocker arms move as a single unit. In this state, all the rocker arms are driven by cam lobe C, opening and closing the valves at the valve timing and valve lift set for high operation.

At High rpm:

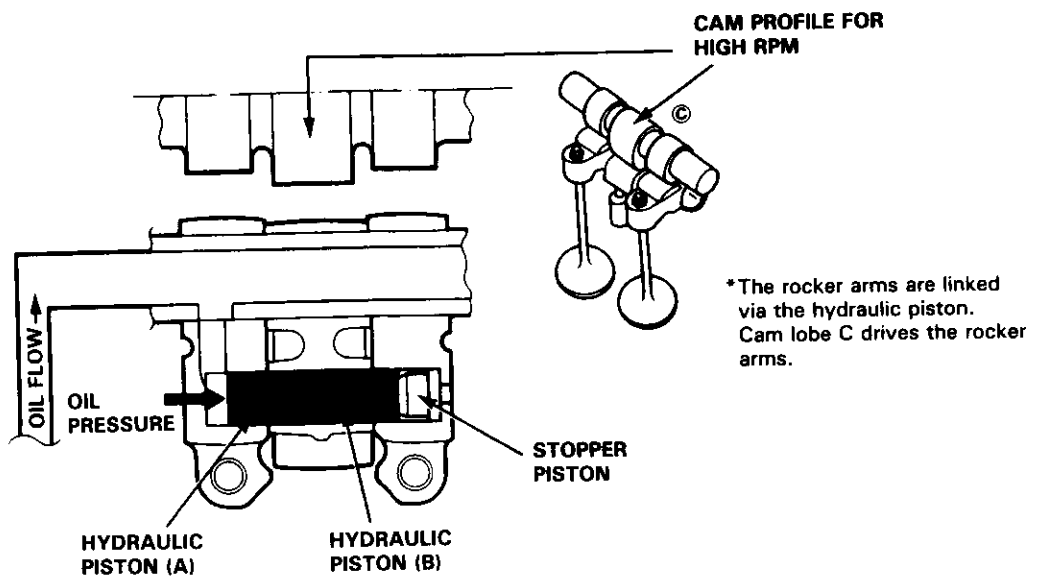



Control System

The control system for this mechanism, as shown below, constantly monitors the changes in engine status such as load, rpm and vehicle speed. this information is transmitted to the Engine Control Module (ECM).

Valve Timing Change Conditions

Engine Speed: 4,900 rpm or higher

Vehicle Speed: 19 mph (30 km/h) or faster

Engine Coolant Temperature: 140°F (60°C) or higher

Control System

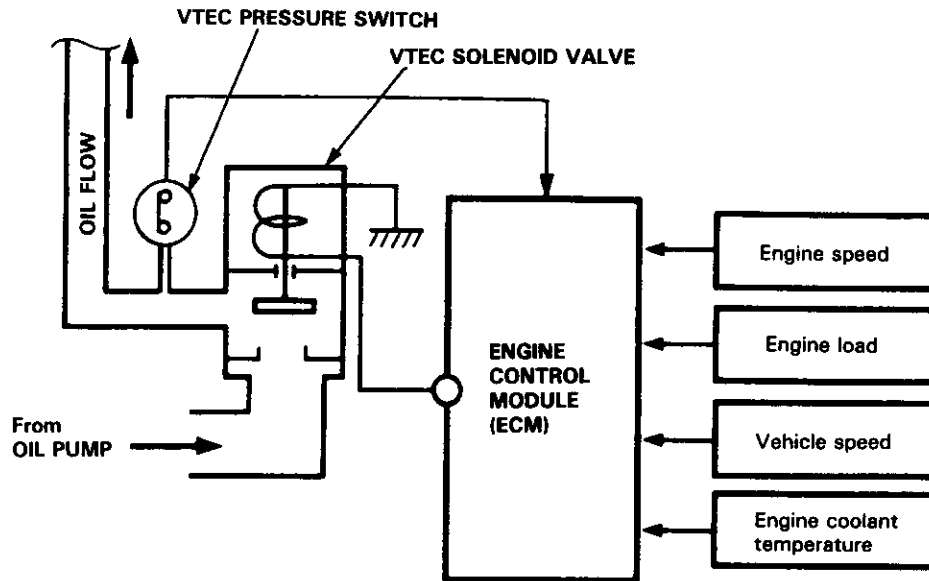

(cont'd)

VTEC

Control System (cont'd)

Lost Motion Mechanism

The mid rocker arm is always driven by the high-speed cam lobe, even at low speeds. At low speeds, the lost motion mechanism keeps the mid rocker arm in contact with the high-speed cam lobe. At high speeds, the lost motion mechanism acts as part of the valve spring load.

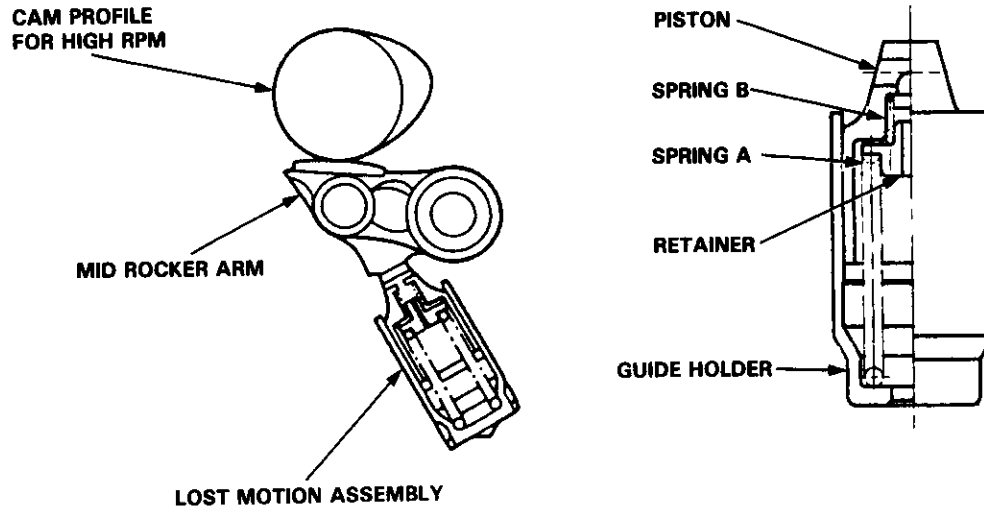

Hydraulic Pressure Control Mechanism

VTEC solenoid valve/VTEC pressure switch

The VTEC solenoid valve, in response to a signal from the ECM, closes the oil passage to the rocker arm at low speed. This cuts oil pressure to the hydraulic pistons in the rocker arms so the arms operate independently. At high speed, the ECM opens the VTEC solenoid valve. The increased oil pressure causes the hydraulic pistons to lock the primary, secondary, and mid rocker arms together.

The VTEC pressure switch serves as a sensor to determine if the switch-over has taken place in response to the ECM signal.

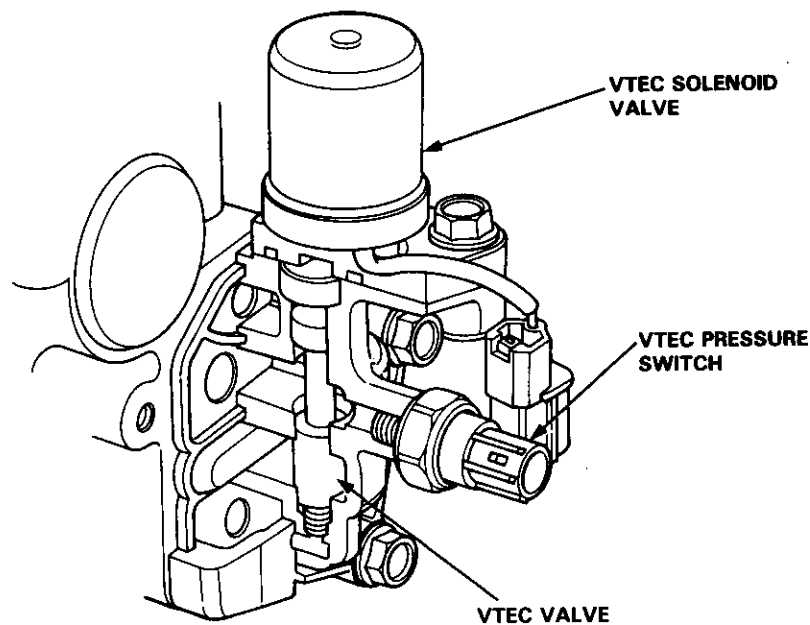



Cylinder Head

Outline

The one-piece cylinder head is made of aluminum alloy to reduce the weight while increasing efficiency. The combustion chamber is a compact pent roof shape, center plug type. The cylinder head uses a DOHC 4-valve system with 2 intake valves and 2 exhaust valves arranged for cross flow. Combustion is stable due to the optimization of the ignition timing, compression ratio and valve timing.

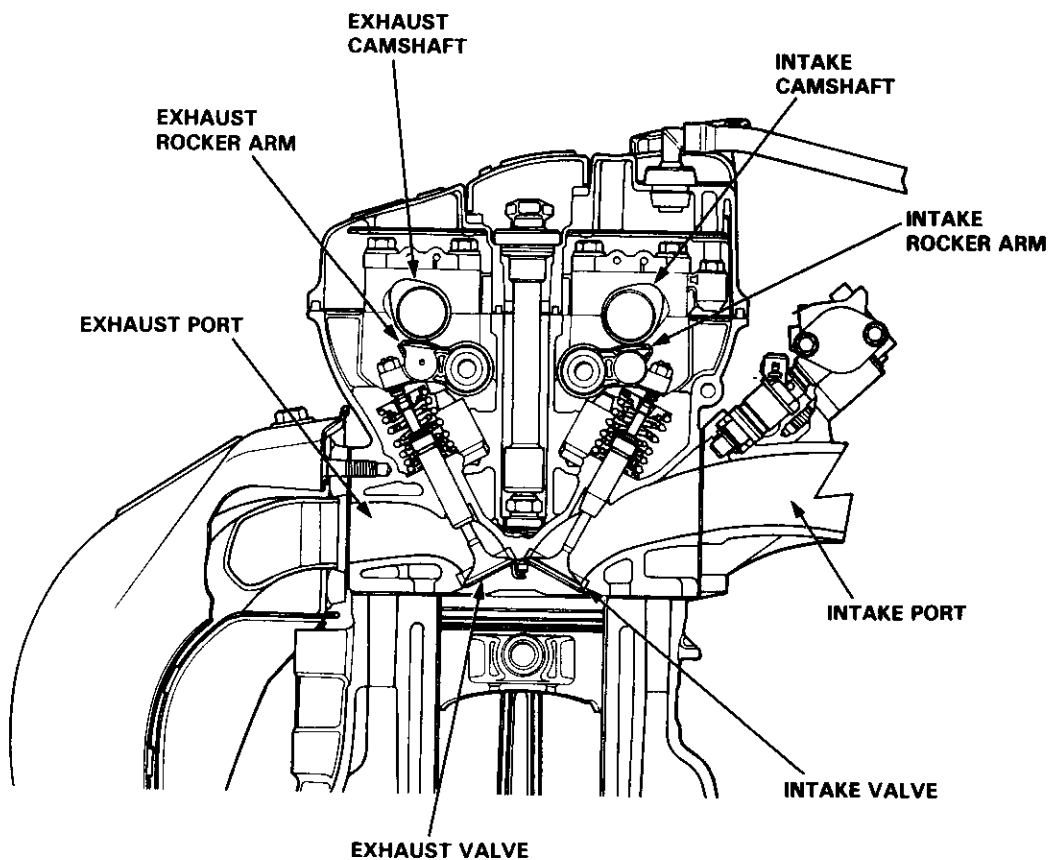

Cylinder Head

Camshafts

The camshaft is a cast piece. By improving dimensional accuracy, it became possible to achieve minimum space between cams, thus allowing a more compact cylinder head. Each camshaft is supported on five bearing journals with forced lubrication. On the left end of each camshaft is a driven pulley. The exhaust and intake cycles require a total of 24 cam lobes to open and close the valves.

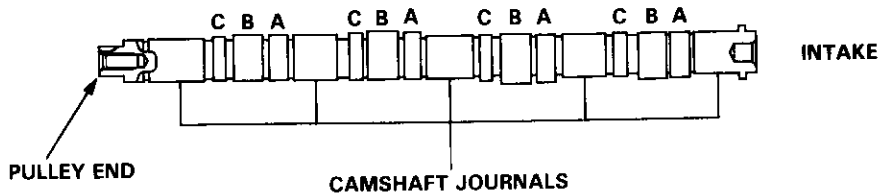
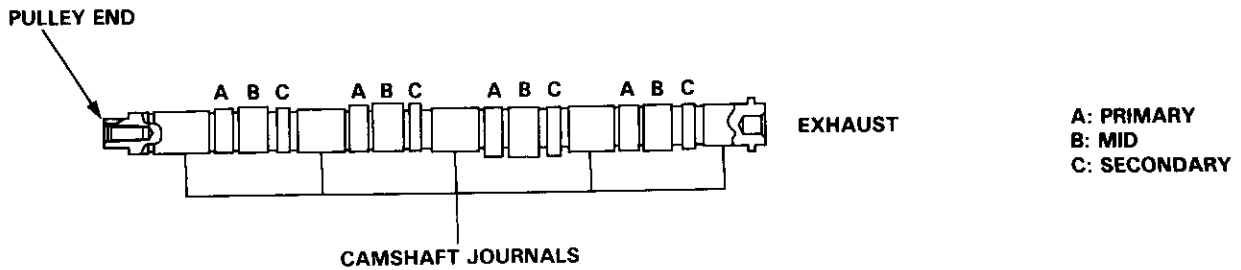

Low-speed valve timing

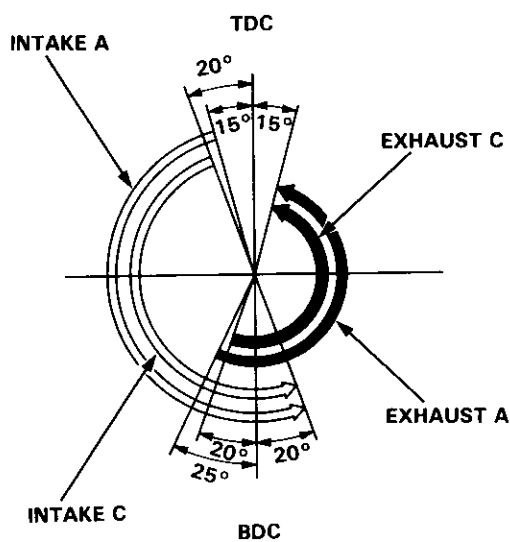

High-speed valve timing

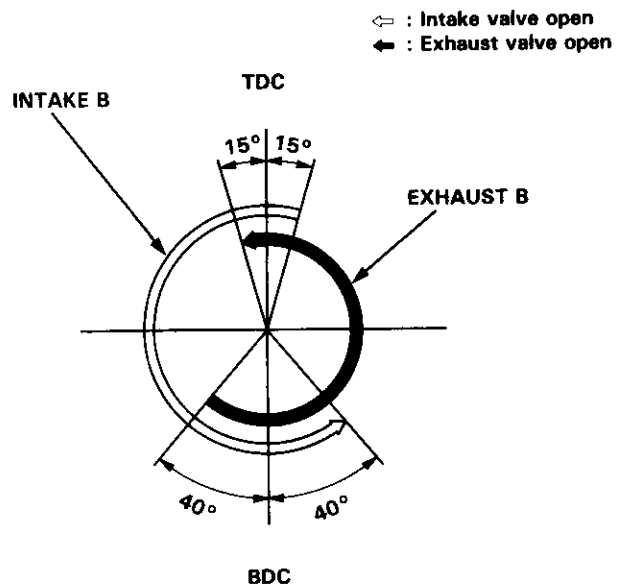

TDC: Top dead center
BDC: Bottom dead center



Valves and Valve Springs

The valves are opened and closed by rocker arms driven by the camshaft.

Light weight and large diameter valves made of a high strength metal with small diameter stems are used. The air resistance is decreased by the slender stems and the intake efficiency is increased by inlet ports that match with large diameter valves.

Valve specifications

Unit: mm (in)

ITEM \ VALVE	INTAKE	EXHAUST
HEAD DIAMETER	35.0 (1.38)	30.0 (1.18)
STEM DIAMETER	5.5 (0.22)	5.5 (0.22)
OVERALL LENGTH	106.75 (4.203)	106.95 (4.211)
VALVE LIFT	Secondary: 8.0 (0.31) Mid: 11.5 (0.45)* Primary: 6.5 (0.26)	Secondary: 7.5 (0.30) Mid: 10.5 (0.41)* Primary: 6.0 (0.24)

* Indicates high-speed valves

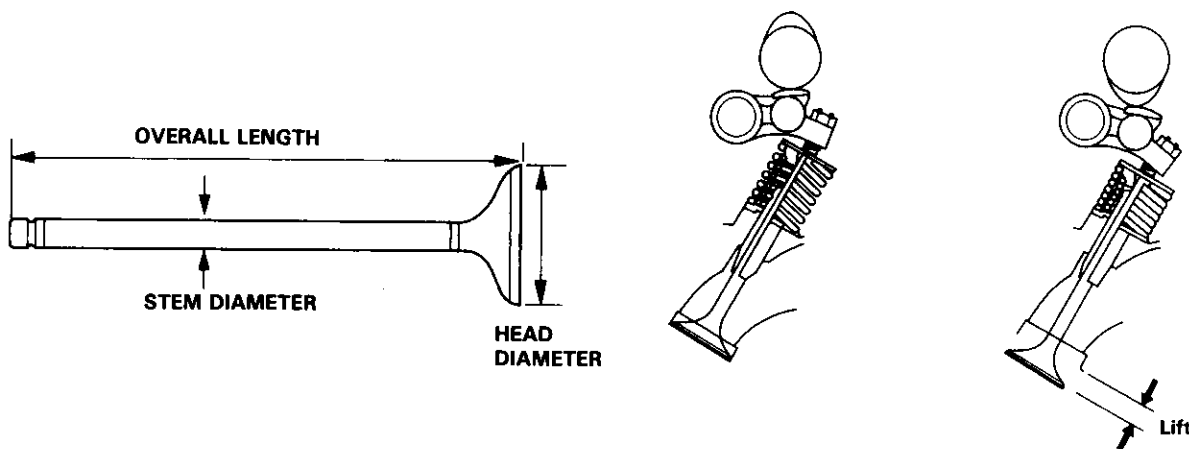

The valve spring wire uses a modified cross-section to valve lift in a limited space.

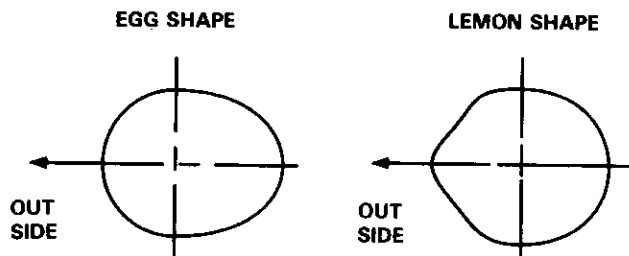

Belt Tensioner

Outline

The tensioners for the balancer shaft drive belt and the timing belt are arranged in parallel on a single axis for a more compact configuration. This tensioner allows easy belt maintenance.

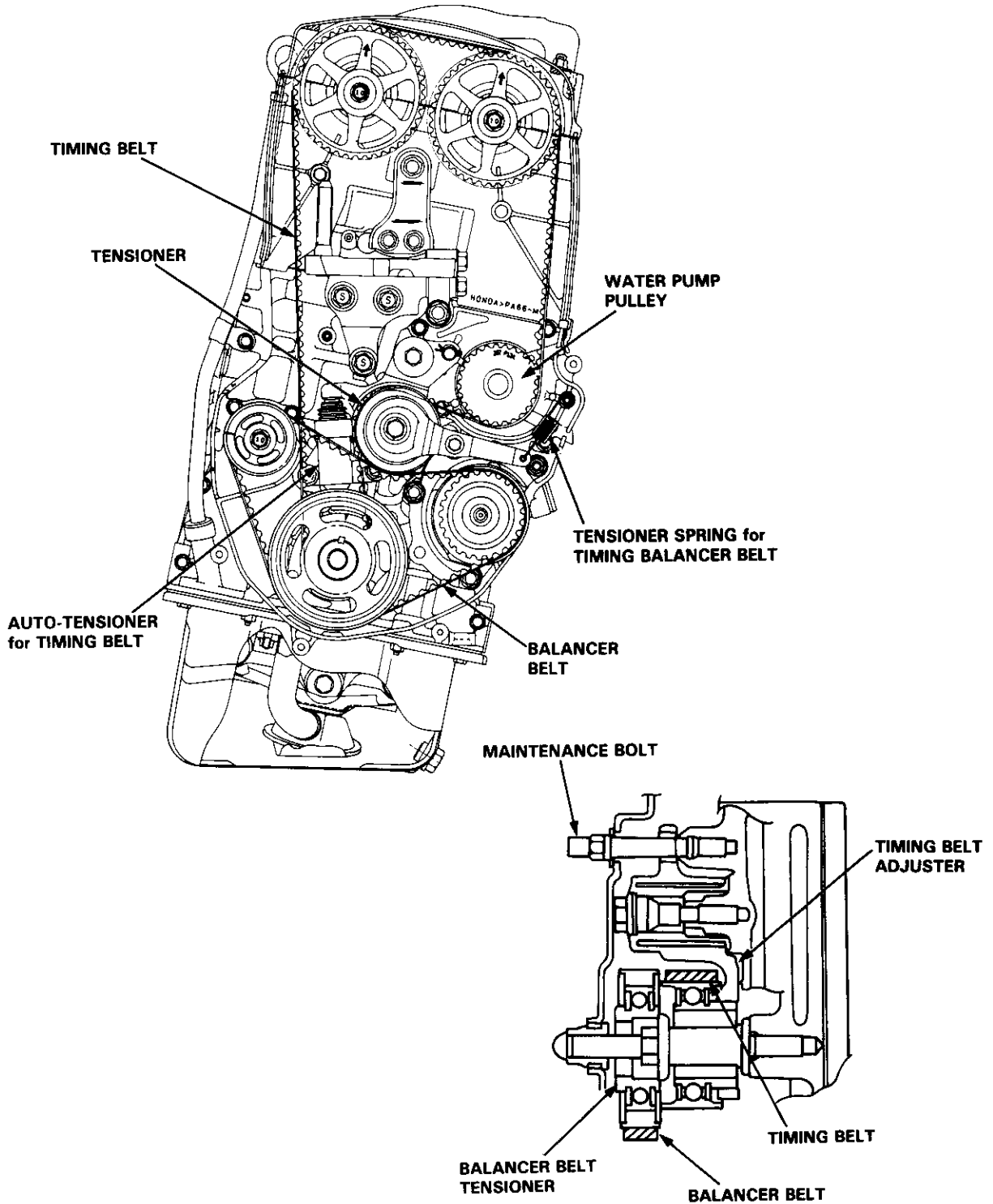



— Auto-tensioner

The auto-tensioner uses a torsion spring to regulate the timing belt tension. The main components are the torsion spring, a male screw and a female rod. The assembly is filled with oil and sealed. The spring turns the male screw, which pushes the female rod out against the belt. The design is such that the rod cannot be pushed back into the housing by belt tension. To pull the female rod back into the assembly, the male screw must be turned with a screwdriver.

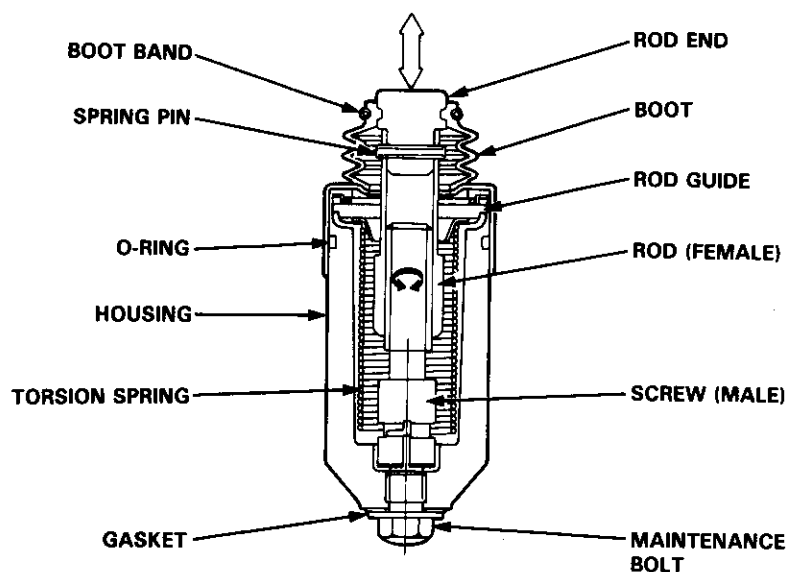

Mechanism:



- ① The male screw is rotated by the torsion spring.

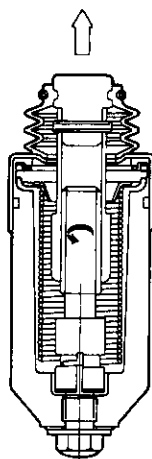

- ② The female rod is pushed out as the rod rotates.

Belt Reaction Force

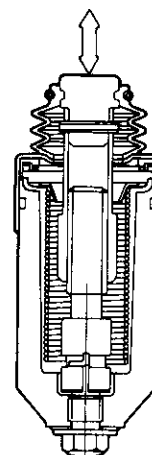

- ③ The rod stops when the force of the torsion spring and the timing belt equalize.

Cylinder Block

The cylinder block is a closed deck design made of aluminum alloy. The cylinder sleeves are made of FRM, a composite material of aluminum, alumina fiber and carbon fiber. The bores in the cylinder block for the balancer shafts and the deep skirt design improve the rigidity of the block.

Cylinder specifications

Bore x Stroke	87.0 x 90.7 mm (3.43 x 3.57 in)
Bore Pitch	94.0 mm (3.70 in)
Block Height	219.52 (8.643 in)
Skirt Depth	50.0 mm (1.97 in)
Displacement	2.157 cm ³ (131.6 cu-in)

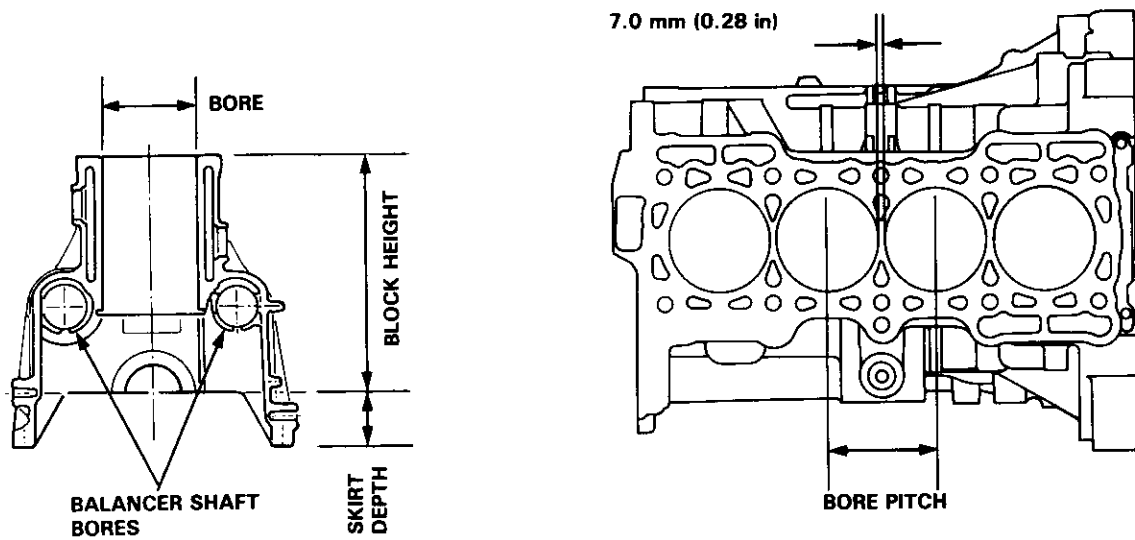

Oil Flow



Lubrication of the crankshaft and connecting rod bearings is done by oil pumped through the main bearing caps and into passages in the crankshaft. The pistons and cylinder walls are lubricated by oil spray nozzles mounted on the cylinder block.

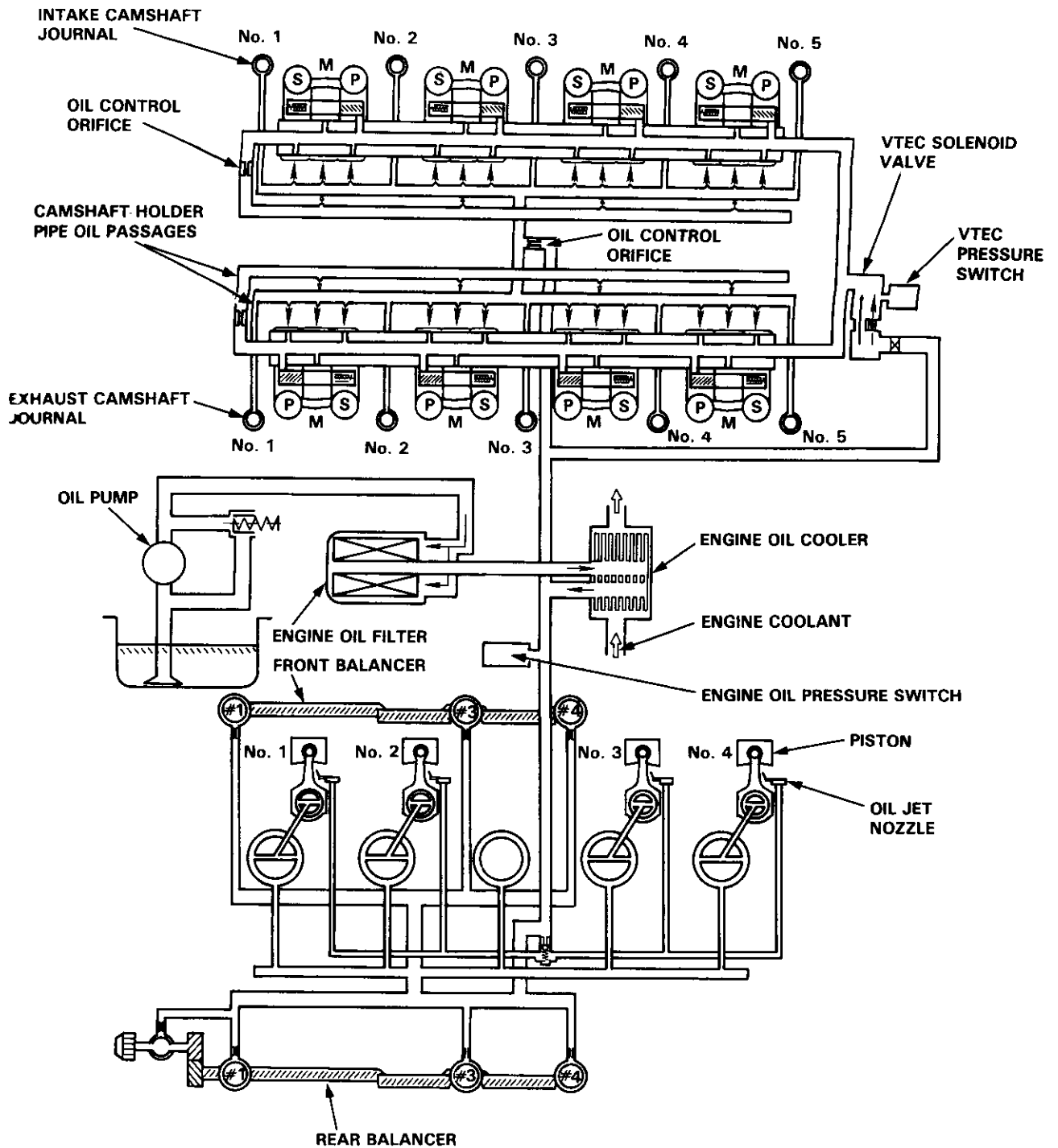

(cont'd)

Oil Flow

(cont'd)

Oil pumped to the cylinder head serves two purposes; to lubricate the components and to operate the VTEC. Oil is pumped into the camshaft holder to lubricate the journals, and it sprays from orifices in the holder to lubricate the rocker arms and valves. Oil is also supplied to the VTEC solenoid valve. At high RPM, this valve opens and oil is pumped at high pressure through the rocker arm shafts to operate the VTEC.

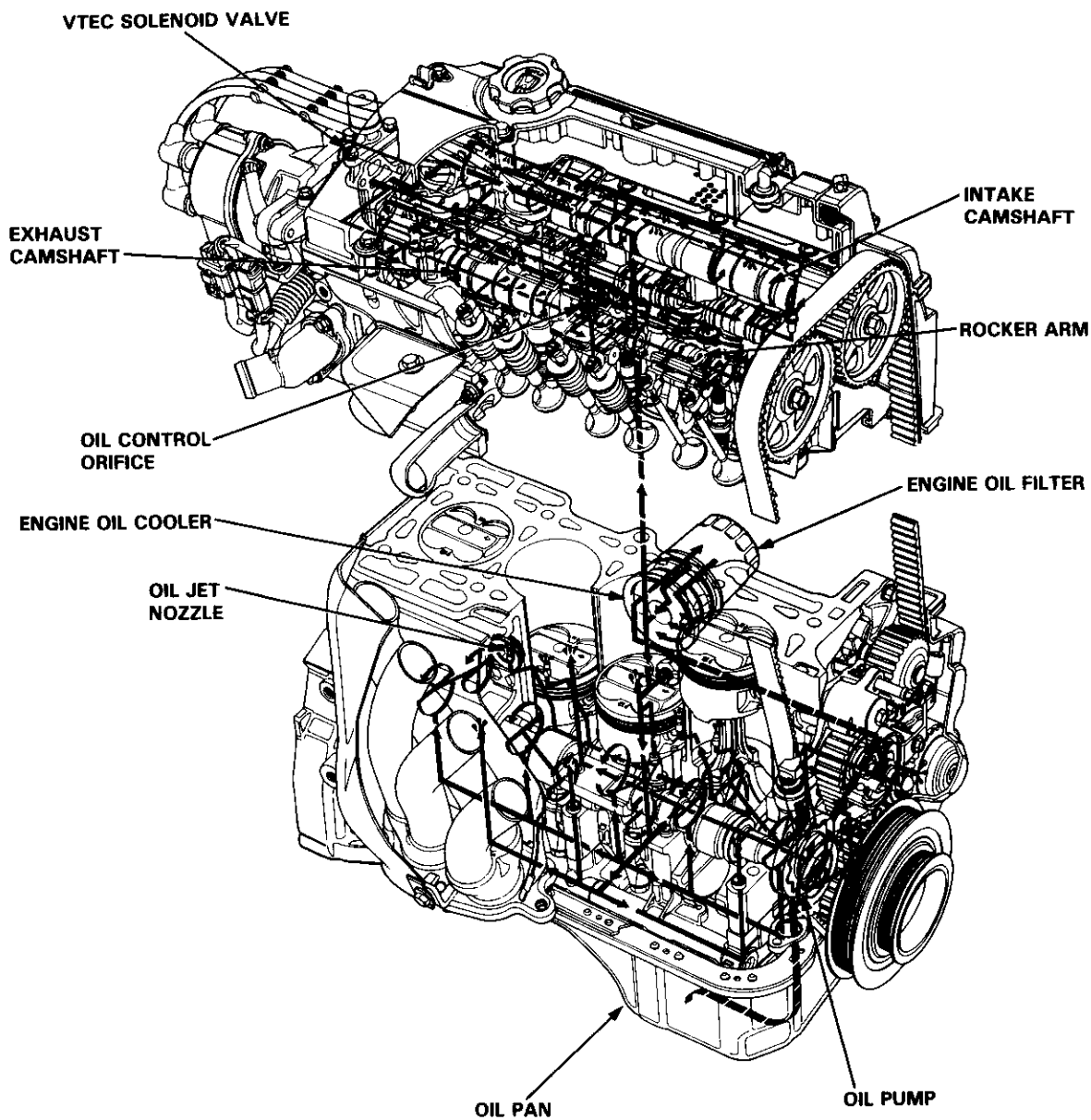

is
er
gh

Engine Removal/Installation



Engine Removal/Installation

⚠ WARNING

- Make sure jacks and safety stands are placed properly and hoist brackets are attached to the correct positions on the engine.
- Make sure the car will not roll off stands and fall while you are working under it.

CAUTION:

- Use fender covers to avoid damaging painted surfaces.
- Unspecified items are common.
- Unplug the wiring connectors carefully while holding the connector portion to avoid damage.
- Mark all wiring and hoses to avoid misconnection. Also, be sure that they do not contact other wiring or hoses or interference with other parts.

NOTE: The radio may have a coded theft protection circuit. Be sure to get the customer's code number before — Disconnecting the battery. — Removing the No. 43 (10 A) fuse (In the under-hood fuse/relay box). — Removing the radio.

After service, reconnect power to the radio and turn it on.

When the word "CODE" is displayed, enter the customer's 5-digit code to restore radio operation.

1. Secure the hood as far open as possible.
2. Disconnect the battery negative terminal first, then the positive terminal.
3. Remove the radiator cap.

⚠ WARNING Use care when removing the radiator cap to avoid scalding by hot coolant or steam.

4. Raise the hoist to full height. Remove the front wheels and the engine splash shield.

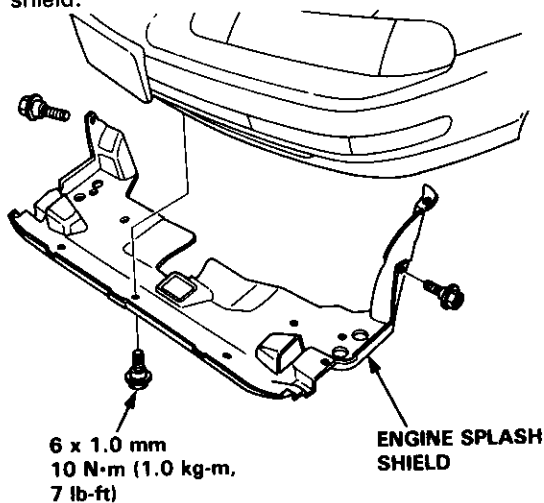

5. Loosen the drain plug on the radiator.
6. Drain the transmission oil/fluid. Reinstall the drain plug using a new washer.
7. Drain the engine oil. Reinstall the drain plug using a new washer.

CAUTION: Do not overtighten the drain plug.

8. Lower the hoist.
9. Remove the air cleaner housing and intake air duct.

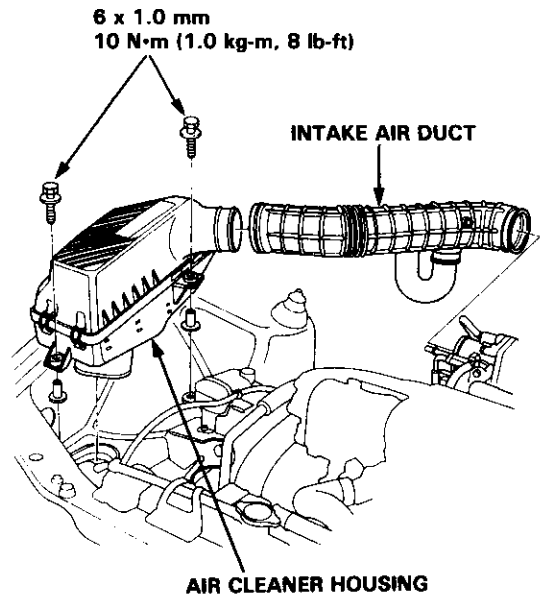

10. Remove the pulsed secondary air injection (PAIR) vacuum tank and bracket.

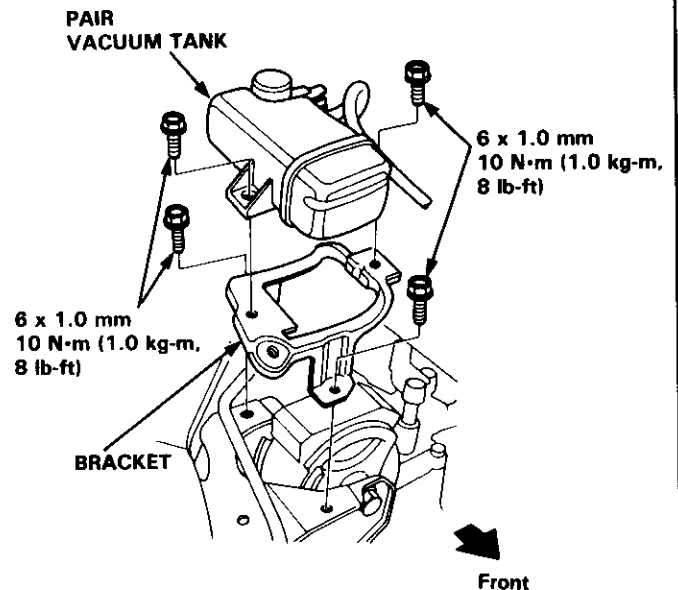



11. Remove the battery, battery base, battery cable and starter cable.

MANUAL TRANSMISSION (M/T):

8 x 1.25 mm
22 N·m (2.2 kg-m,
16 lb-ft)

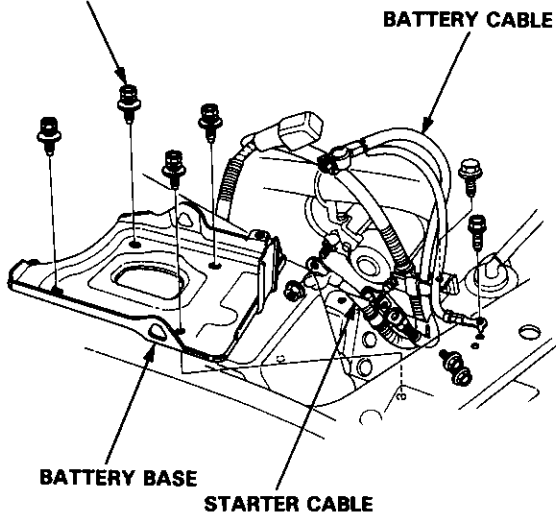

AUTOMATIC TRANSMISSION (A/T):

NOTE: When installing the starter cable clamp, make sure the tab is in the hole in the bracket.

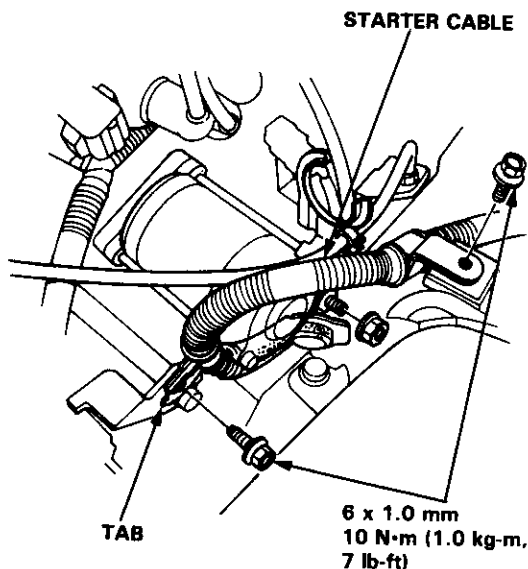

12. Relieve fuel pressure by slowly loosening the service bolt on the fuel rail about one turn (see section 11).

⚠ WARNING Do not smoke while working on fuel system. Keep open flame or spark away from work area. Drain fuel only into an approved container.

CAUTION:

- Before disconnecting any fuel line, relieve the fuel pressure as described above.
- Place a shop towel over the fuel filter to prevent pressurized fuel from spraying over the engine.

13. Remove the fuel feed hose from the fuel rail.

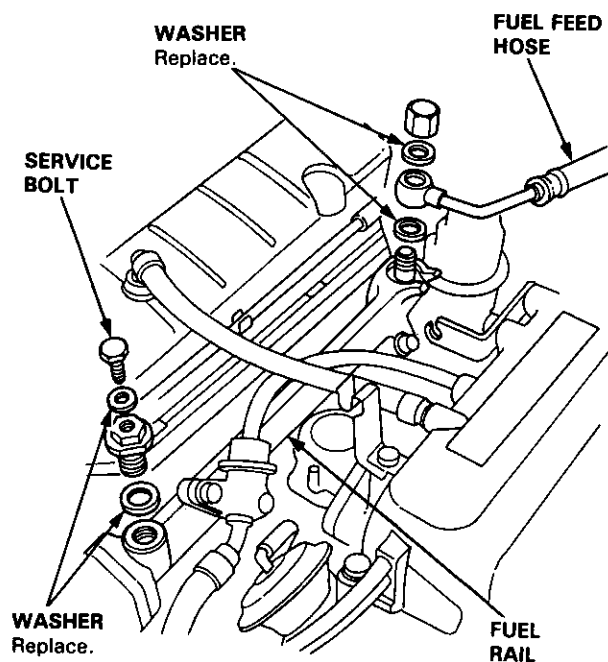

14. Remove the injector resistor connector on the left side of engine compartment.

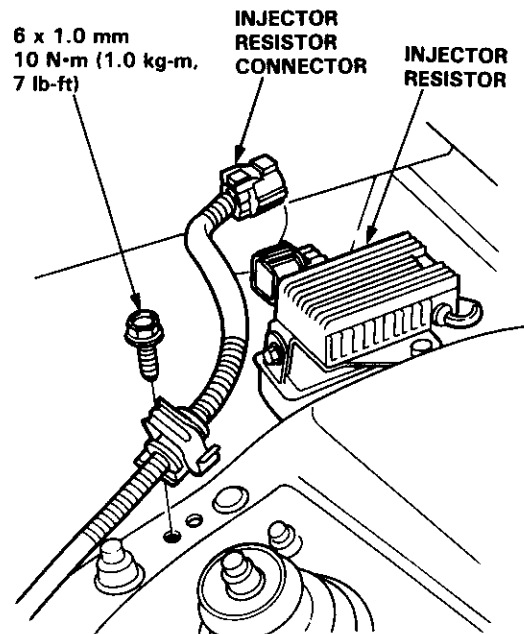

(cont'd)

Engine Removal/Installation

(cont'd)

15. Remove the throttle cable by loosening the locknut, then slip the cable end out of the throttle linkage.

NOTE:

- Take care not to bend the cable when removing it. Always replace any kinked cable with a new one.
- Adjust the throttle cable when installing (see section 11).

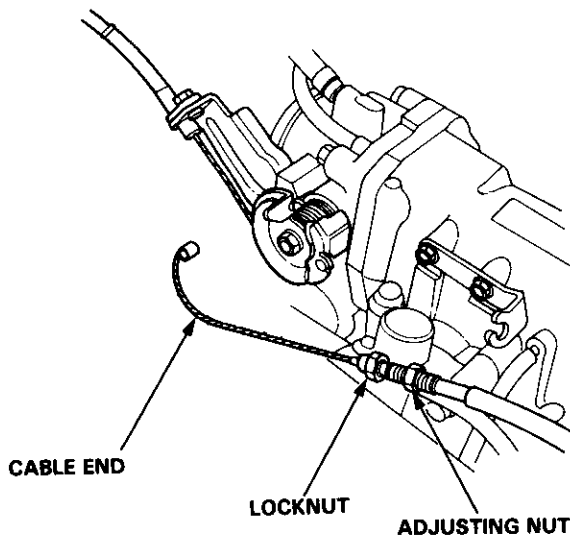

16. Remove the engine wire harness connectors, terminal and clamps on the right side of engine compartment.

17. Remove the power cable from the under-hood fuse/relay box.

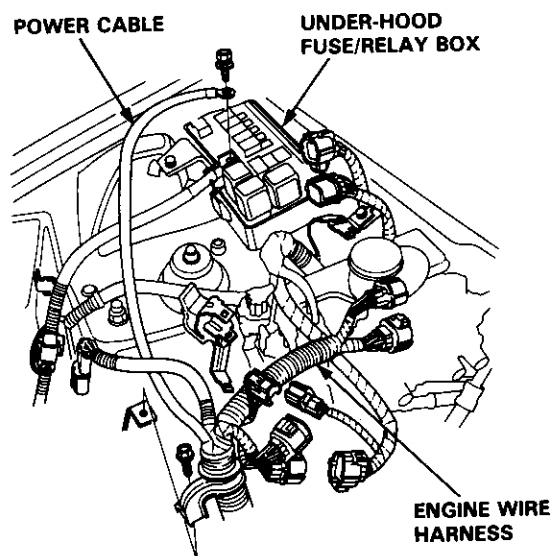

18. Remove the brake booster vacuum hose and emission control vacuum tubes from the intake manifold.

EVAPORATIVE EMISSION (EVAP) CONTROL CANISTER HOSE

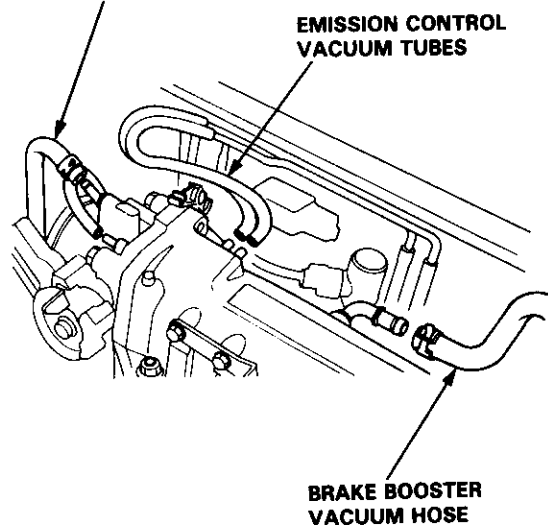

19. Disconnect the connector and vacuum tube, then remove the cruise control actuator.

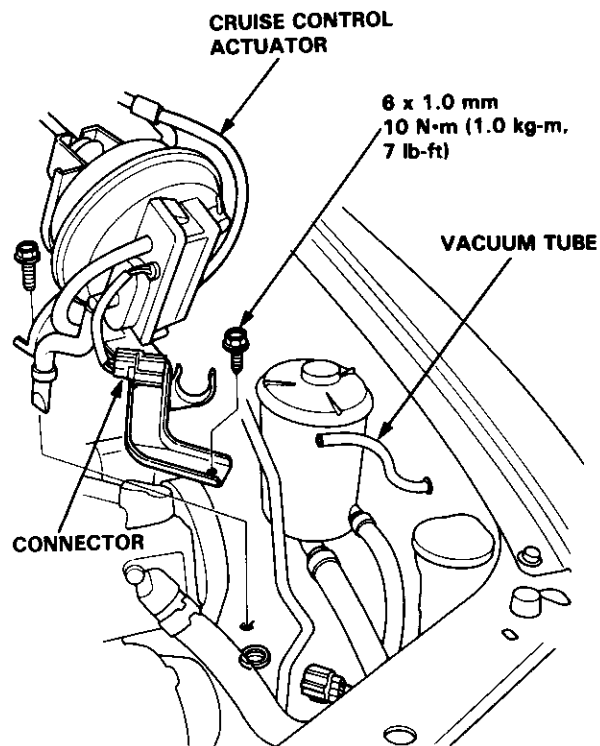



20. Remove the engine ground cable from the body side.
21. Remove the power steering (P/S) pump belt and pump.
 - Do not disconnect the P/S hoses.

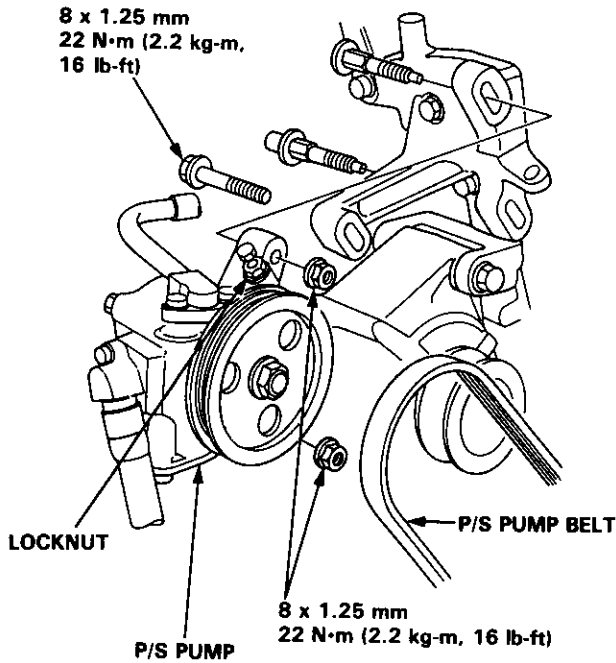

22. Remove the air conditioning (A/C) condenser fan shroud, then install a protector plate on the radiator.

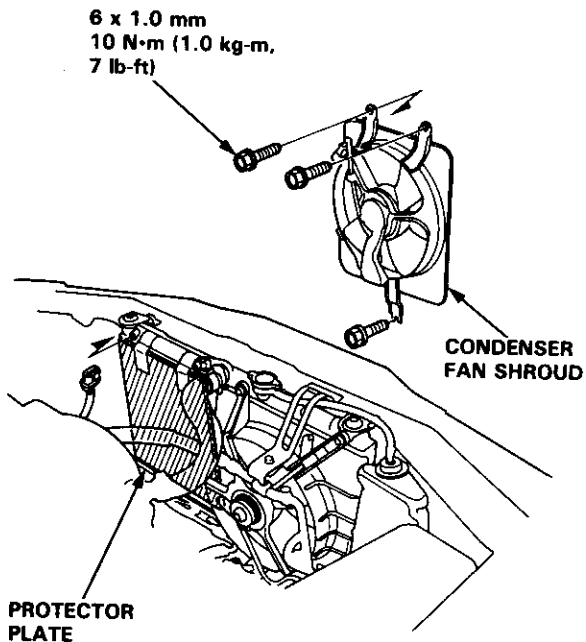

23. Loosen the alternator mounting bolt, nut and adjusting nut, then remove the alternator belt.

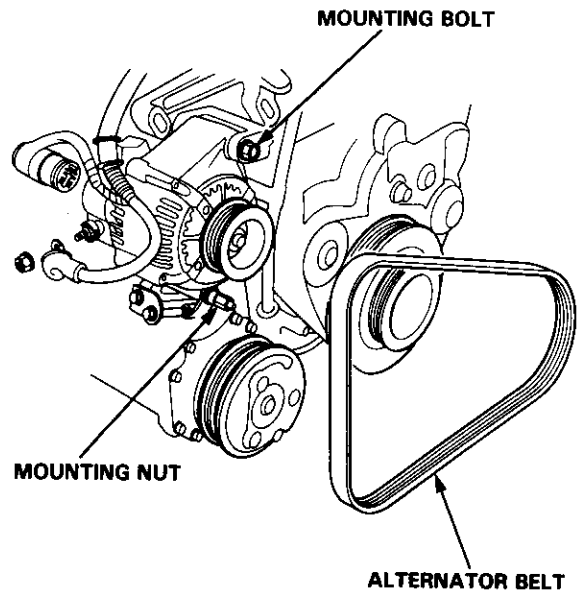

24. Loosen the mounting bolt, then remove the A/C compressor. Disconnect the connector.
 - Do not disconnect the A/C hoses.

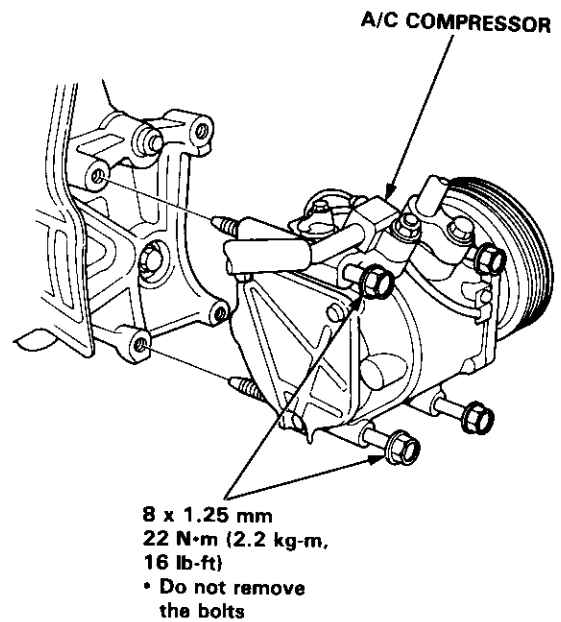

(cont'd)

Engine Removal/Installation

(cont'd)

25. Remove the upper and lower radiator hoses and the heater hoses.

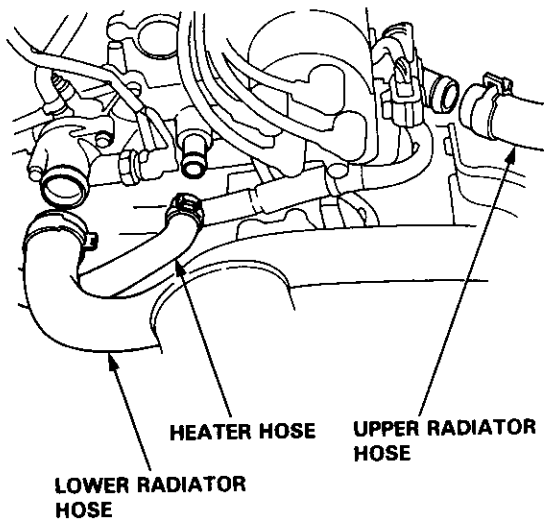

26. Remove the transmission ground cable and the automatic transmission fluid (ATF) cooler hoses (A/T).

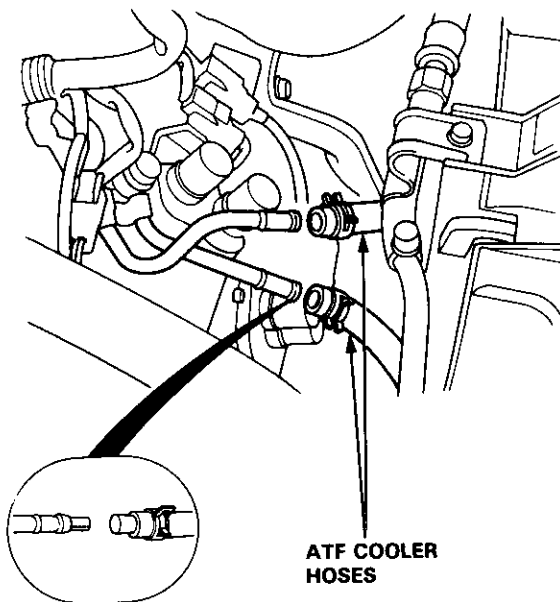

27. Remove the shift cable and select cable (M/T).

NOTE:

- Take care not to bend the cable when removing it. Always replace any kinked cable with a new one.
- Adjust the shift cable and select cable when installing (see section 13).

8 x 1.25 mm
22 N·m (2.2 kg-m, 16 lb-ft)

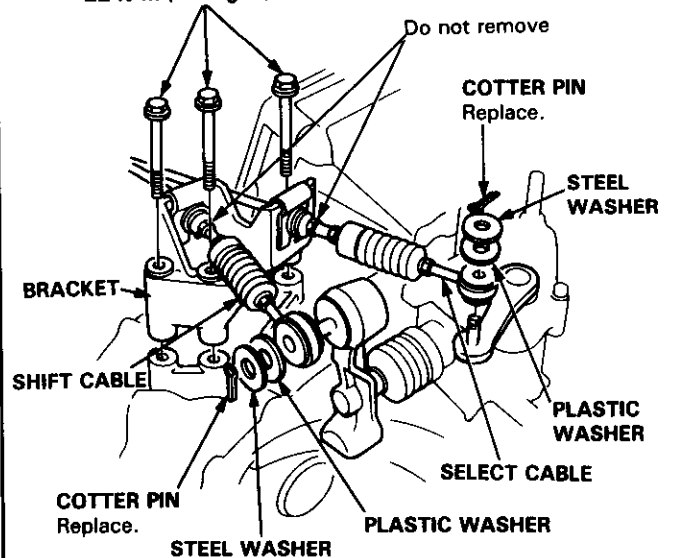

28. Remove the clutch slave cylinder and the pipe/hose assembly (M/T).

NOTE:

- Do not operate the clutch pedal once the slave cylinder has been removed.
- Take care not to bend the pipe.

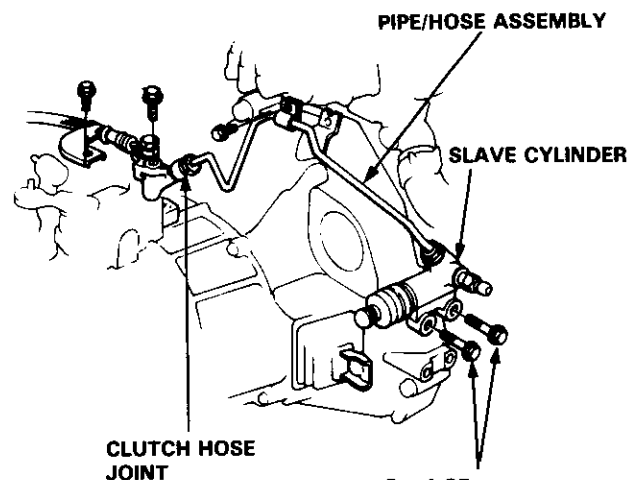

8 x 1.25 mm
22 N·m (2.2 kg-m,
16 lb-ft)



29. Remove the clutch damper assembly.

NOTE: Take care not to bend the pipe.

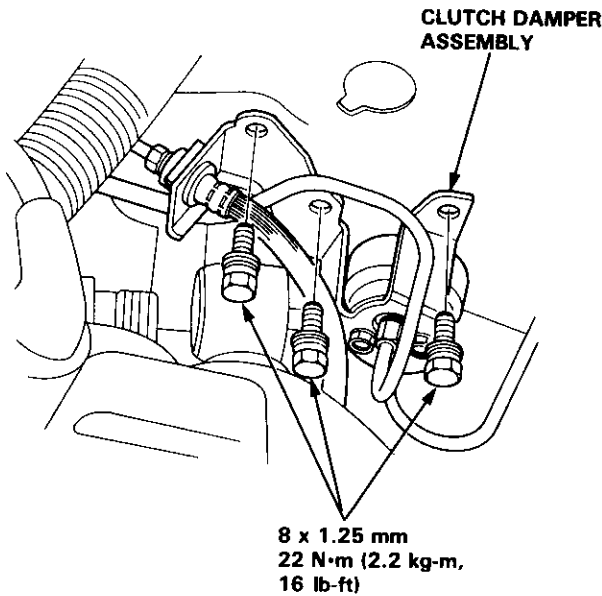

30. Remove the vehicle speed sensor (VSS)/power steering (P/S) speed sensor assembly.

NOTE: Do not disconnect the hoses.

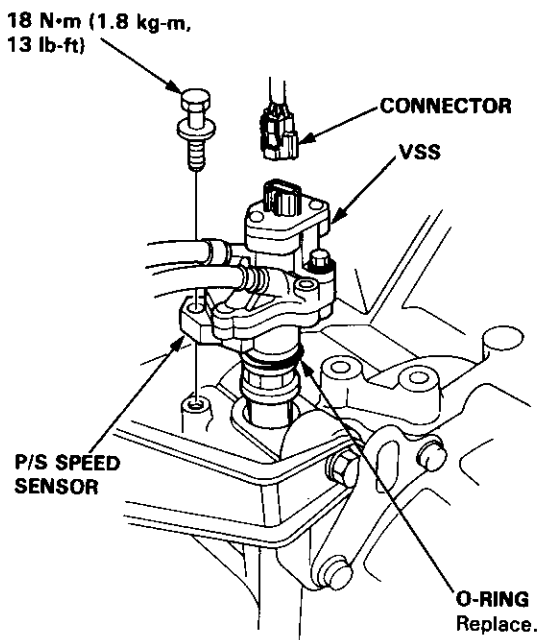

31. Raise the hoist to full height.

32. Remove the exhaust pipe A and bracket.

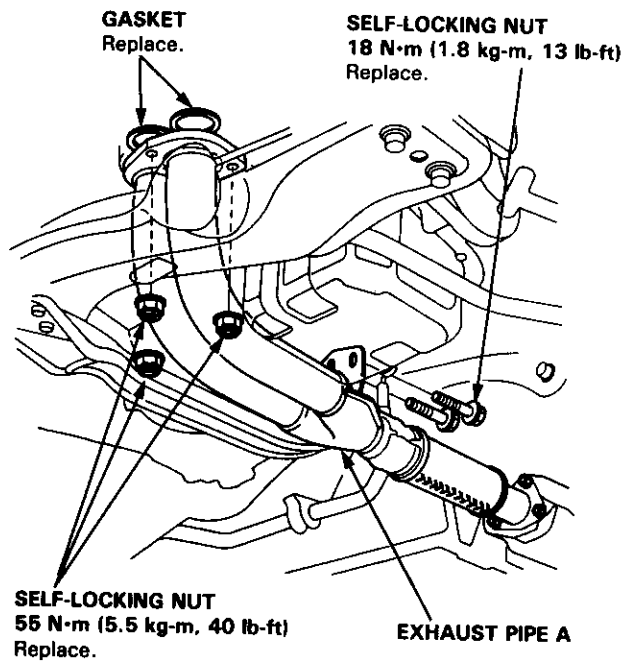

33. Remove the A/T shift cable (A/T).

NOTE:

- Take care not to bend the cable when removing it. Always replace any kinked cable with a new one.
- Adjust the shift cable when installing (see section 14).

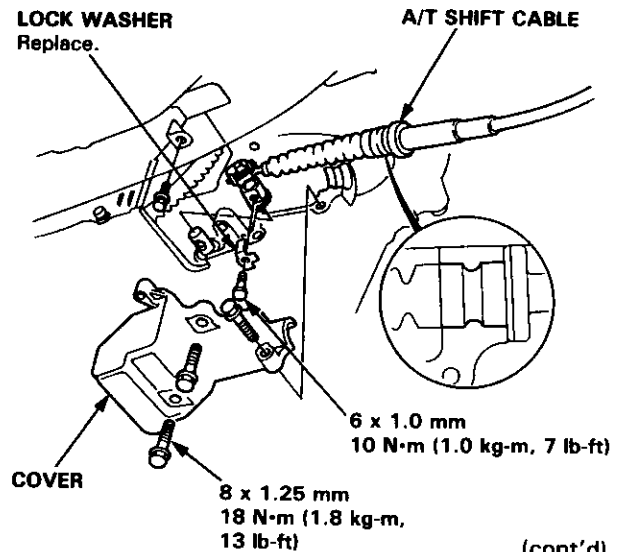

(cont'd)

Engine Removal/Installation

(cont'd)

34. Remove the damper fork.

SELF-LOCKING BOLT
10 x 1.25 mm
44 N·m (4.4 kg-m, 32 lb-ft)
Replace.

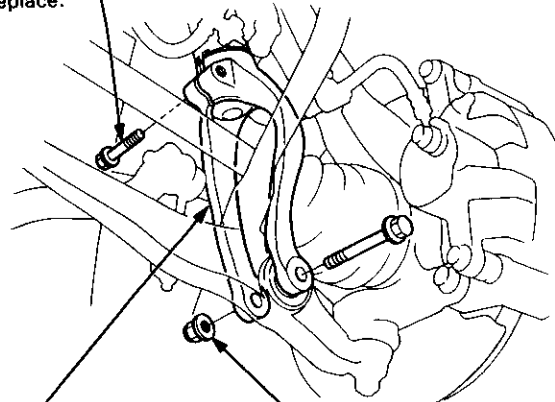

DAMPER FORK

SELF-LOCKING NUT
12 x 1.25 mm
65 N·m (6.5 kg-m, 47 lb-ft)
Replace.

35. Disconnect the suspension lower arm ball joint with the special tool. Refer to section 18 for the procedure.

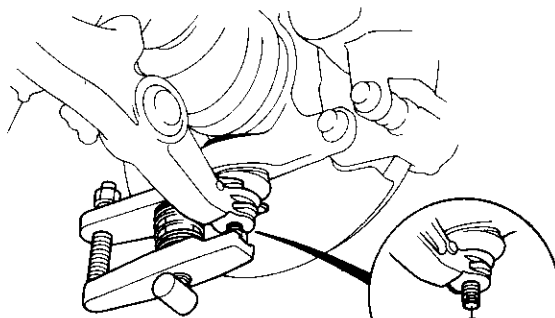

CASTLE NUT
14 x 2.0 mm
50–60 N·m
(5.0–6.0 kg-m,
36–43 lb-ft)

COTTER PIN
Replace.

36. Remove the driveshafts.

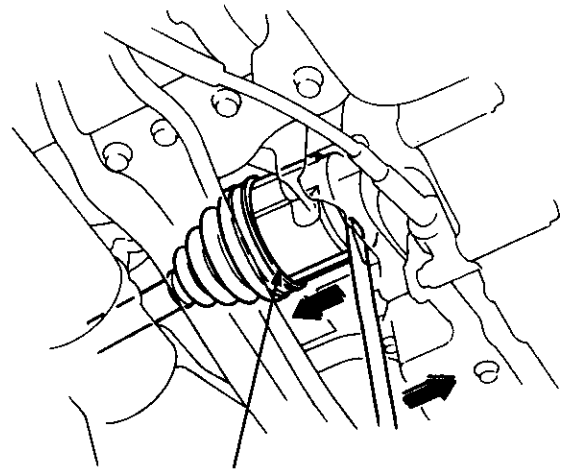

DRIVESHAFT

37. Swing the driveshaft under the fender.

NOTE:

- Coat all precision-finished surfaces with clean engine oil or grease.
- Tie plastic bags over the driveshaft ends.

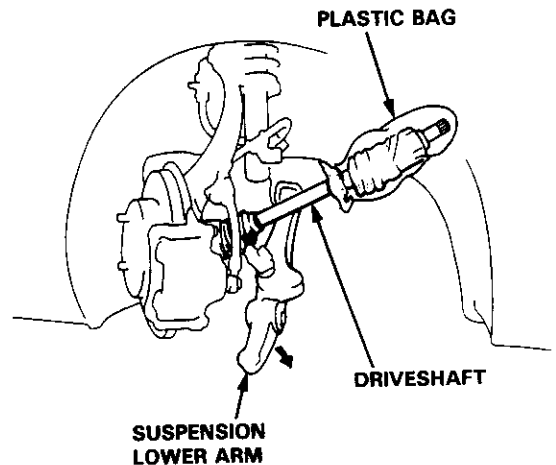



- 38. Lower the hoist.
- 39. Attach the chain hoist to the engine.

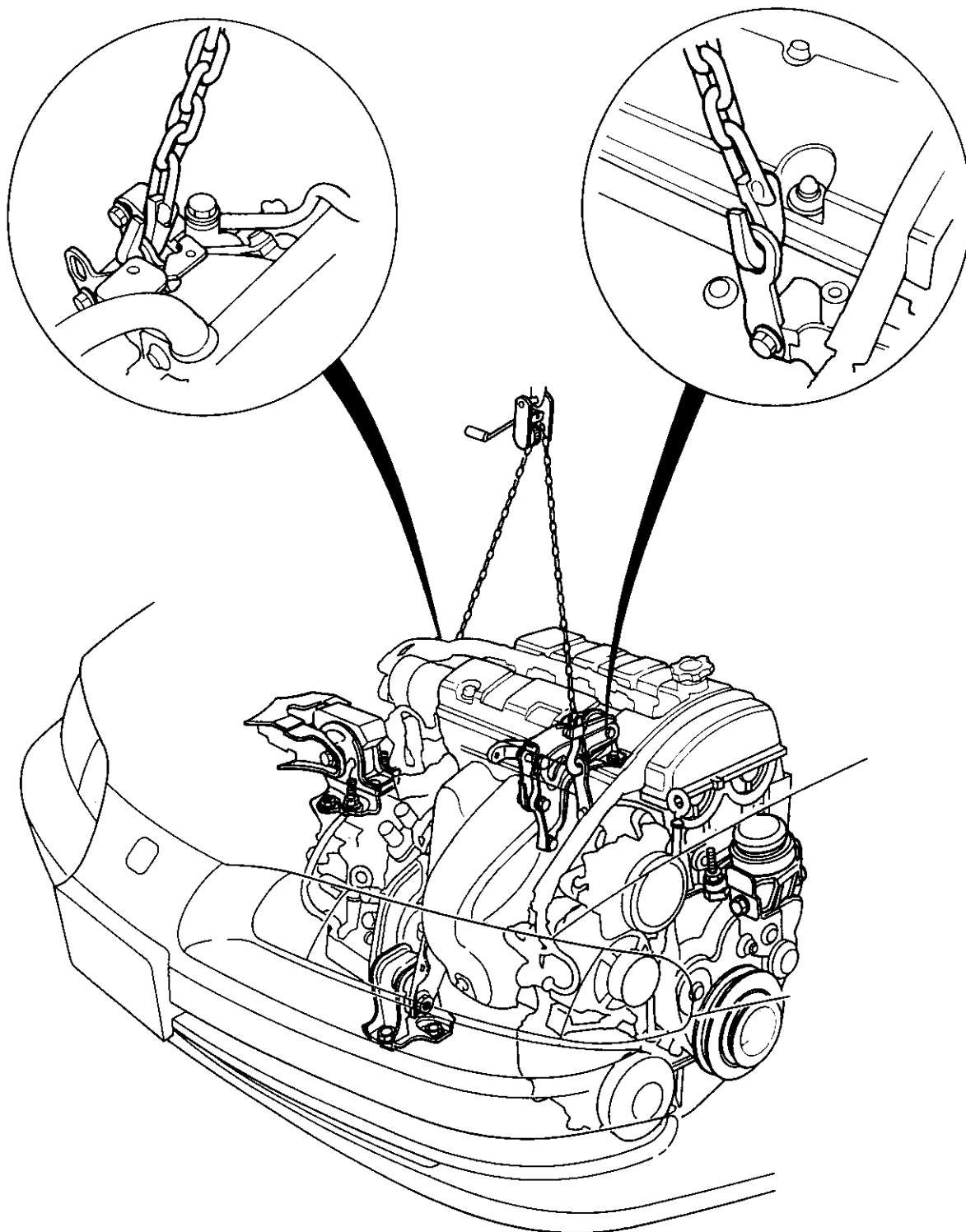

(cont'd)

Engine Removal/Installation

(cont'd)

40. Remove the rear mount bracket.

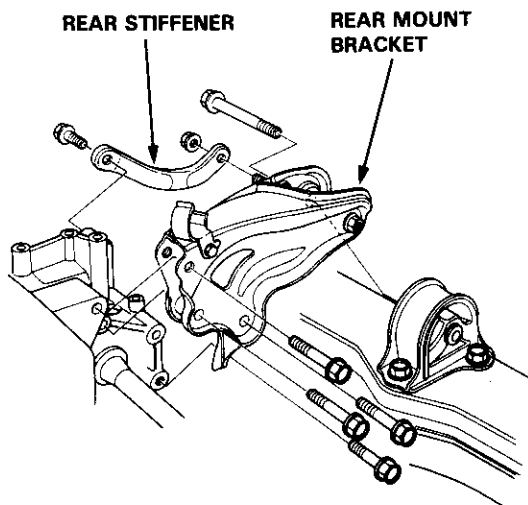

41. Remove the front mount bracket.

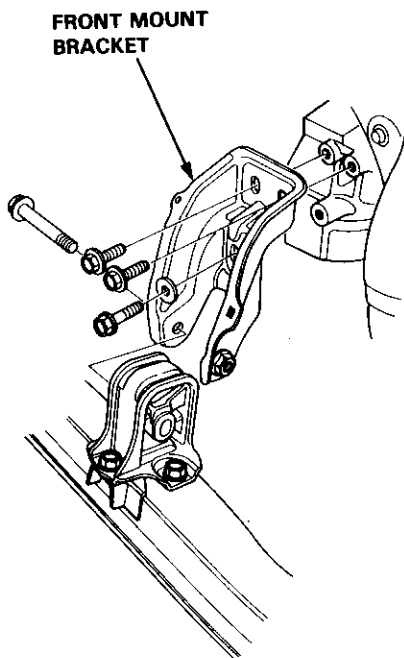

42. Remove the left side engine mount.

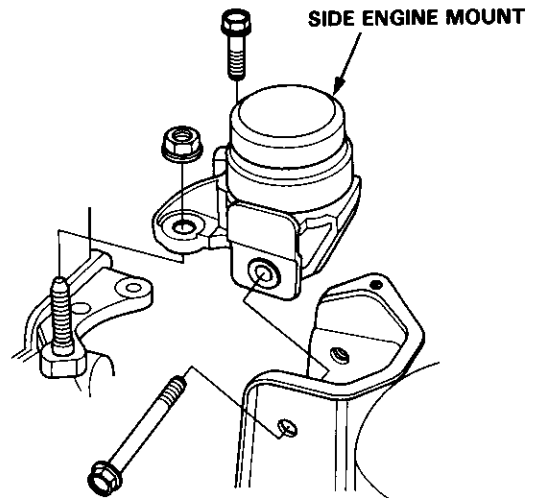

43. Remove the transmission mount and mount bracket.

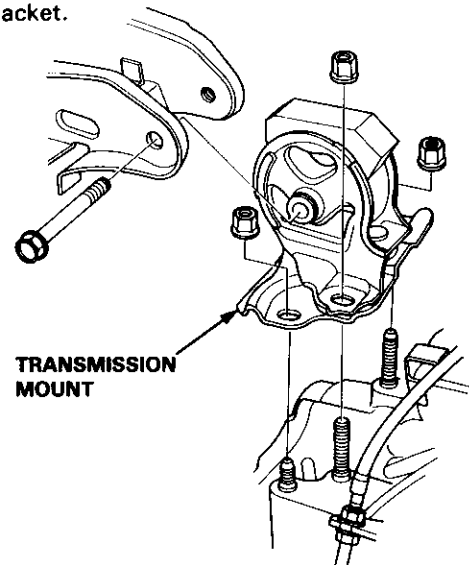

44. Raise the chain hoist to remove all slack from the chain.

45. Check that the engine is completely free of vacuum hoses, fuel and coolant hoses, and electrical wiring.

46. Slowly raise the engine approximately 150 mm (6 in).
Check once again that all hoses and wires have been disconnected from the engine.

47. Raise the engine all the way and remove it from the car.



48. Install the engine in the reverse order of removal.

NOTE: After the engine is in place:

- Torque the engine mounting bolts in the sequence shown below.

CAUTION: Failure to tighten the bolts in the proper sequence can cause excessive noise and vibration, and reduce bushing life; check that the bushings are not twisted or offset.

- Check that the spring clip on the end of each driveshaft clicks in to place.

CAUTION: Install new spring clips.

- Bleed air from the cooling system at the bleed bolt with the heater valve open.
- Adjust the throttle cable tension.
- Check the clutch pedal free play (M/T).
- Check that the transmission shifts into gear smoothly.

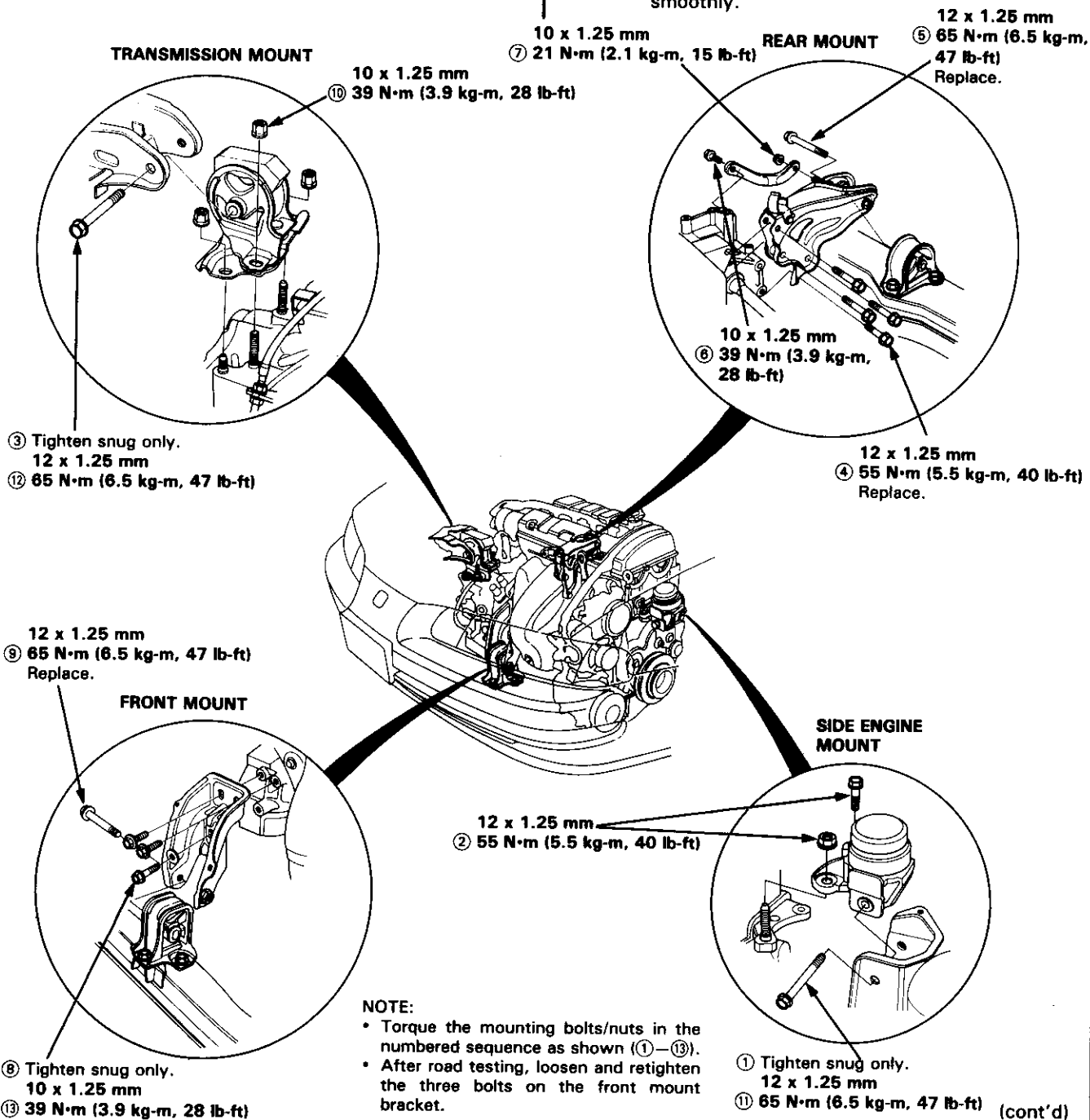

Engine Removal/Installation

(cont'd)

- Adjust the tension of the following drive belts:
 Alternator belt (section 23).
 Power steering pump belt (section 17).
 Air conditioner compressor belt (section 22).
- Clean battery posts and cable terminals with sandpaper, assemble, then apply grease to prevent corrosion.

- Inspect for fuel leakage.
 After connecting all fuel line parts, turn on the ignition switch (do not operate the starter) so that the fuel pump operates for approximately two seconds and the fuel line is pressurized. Repeat this operation two or three times, then check for fuel leakage at any point in the fuel line.

Mount and Bracket Bolts/Nuts Torque Value Specifications:

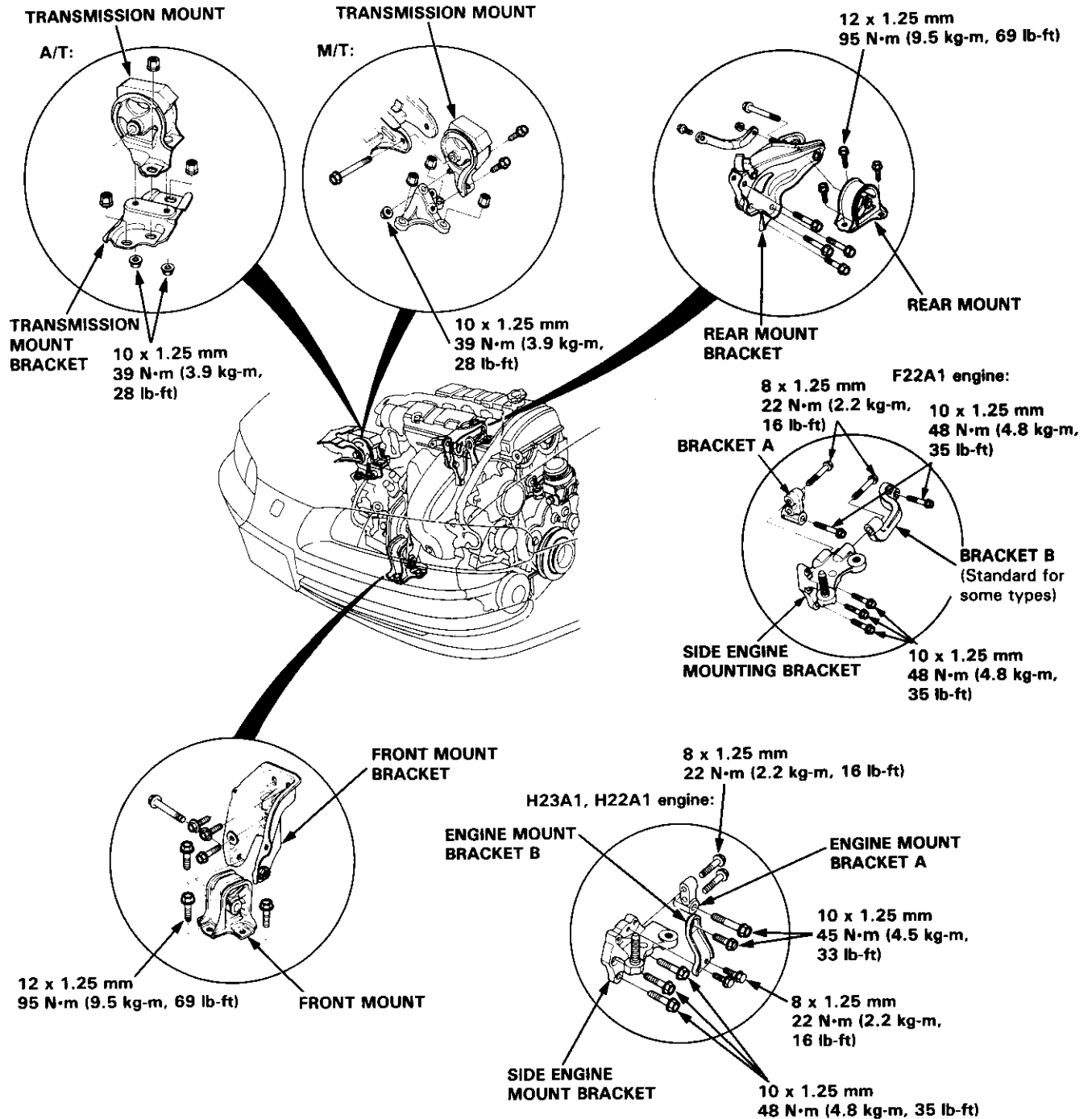



Additional Torque Value Specifications;

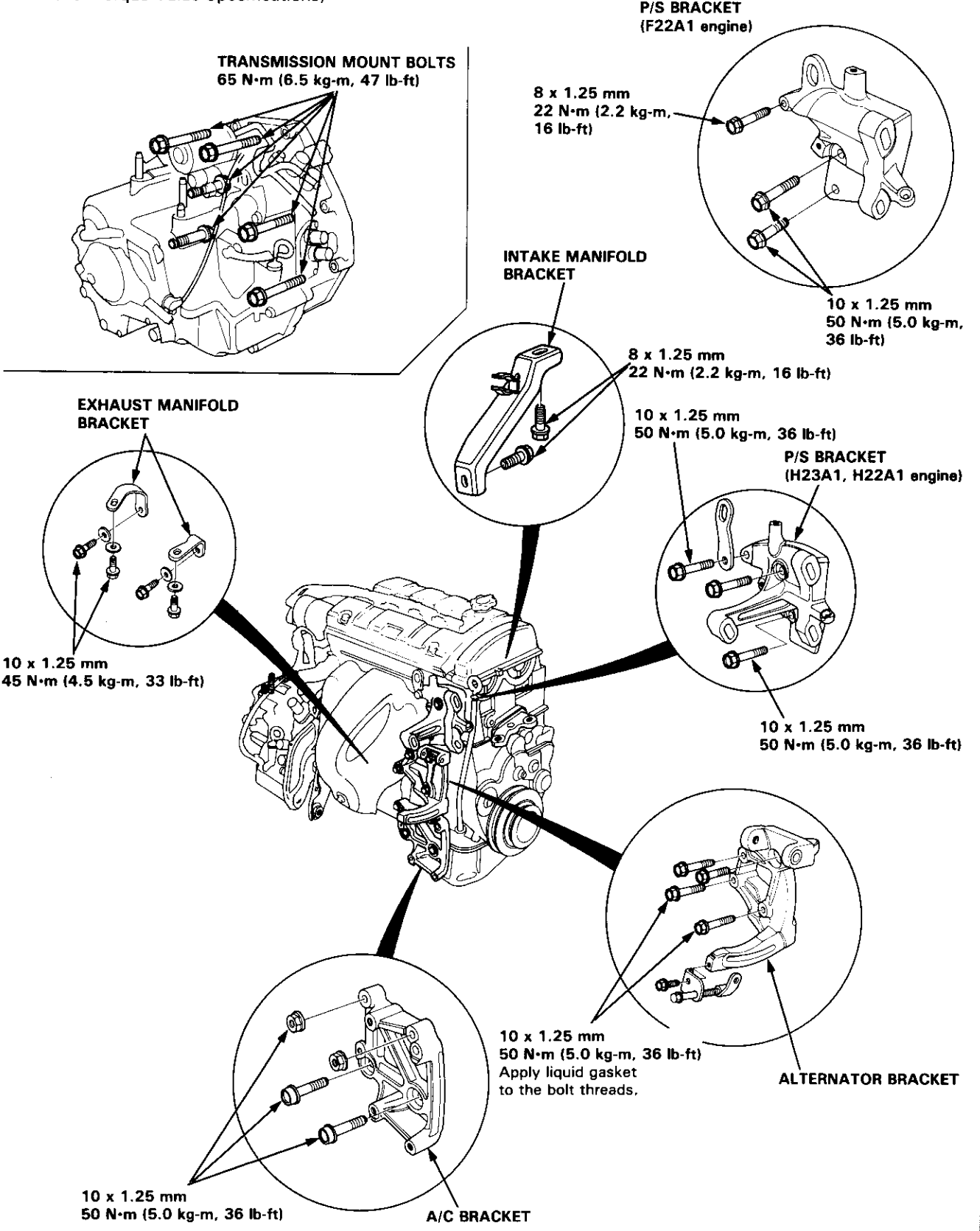

Cylinder Head/Valve Train

F22A1 engine	6-1
H23A1 engine	6-37
H22A1 engine	6-71



Cylinder Head/Valve Train (F22A1 engine)

Special Tools	6-2	Valve Seats	
Illustrated Index	6-3	Reconditioning	6-17
Valve Seals		Valve Guides	
Replacement (Cylinder head removal not required)	6-5	Valve Movement	6-18
Cylinder Head		Replacement	6-19
Removal	6-7	Reaming	6-20
Warpage	6-18	Camshaft/Rocker Arms and Camshaft Seals/Pulley	
Installation	6-23	Installation	6-22
Camshaft Pulley		Timing Belt and Timing Balancer Belt	
Removal	6-12	Illustrated Index	6-25
Rocker Arm Assembly		Replacement	6-29
Removal	6-12	Timing Belt	
Rocker Arms		Inspection	6-26
Overhaul	6-13	Tension Adjustment	6-26
Clearance	6-15	Positioning Crankshaft Before Installing Timing Belt	6-28
Camshaft		Timing Balancer Belt	
Inspection	6-14	Inspection	6-27
Valves, Valve Springs and Valve Seals		Valve Clearance	
Removal	6-16	Adjustment	6-34
Valve Spring and Valve Seal Installation Sequence	6-21		
Valve Installation	6-21		



Special Tools

Ref. No.	Tool Number	Description	Qty	Page Reference
①	07HAH-PJ7010A or 07HAH-PJ7010B	Valve Guide Reamer, 5.5 mm	1	6-20
②	07NAF-PT0010A	Installer Cup	1	6-22
③	07NAF-PT0020A	Installer Shaft	1	6-22
④	07NAG-PT0010A	Seal Guide	1	6-22
⑤	07742-0010100	Valve Guide Driver, 5.5 mm	1	6-19, 20



①

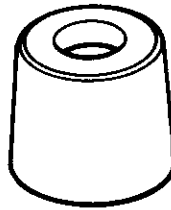

②

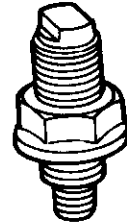

③

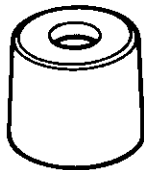

④



⑤

Illustrated Index



CAUTION:

- To avoid damaging the cylinder head, wait until the engine coolant temperature drops below 100°F (38°C) before removing it.
- In handling a metal gasket, take care not to fold it or damage the contact surface of the gasket.

NOTE:

- Use new O-rings and gaskets when reassembling.
- Clean the oil control orifice before installing.

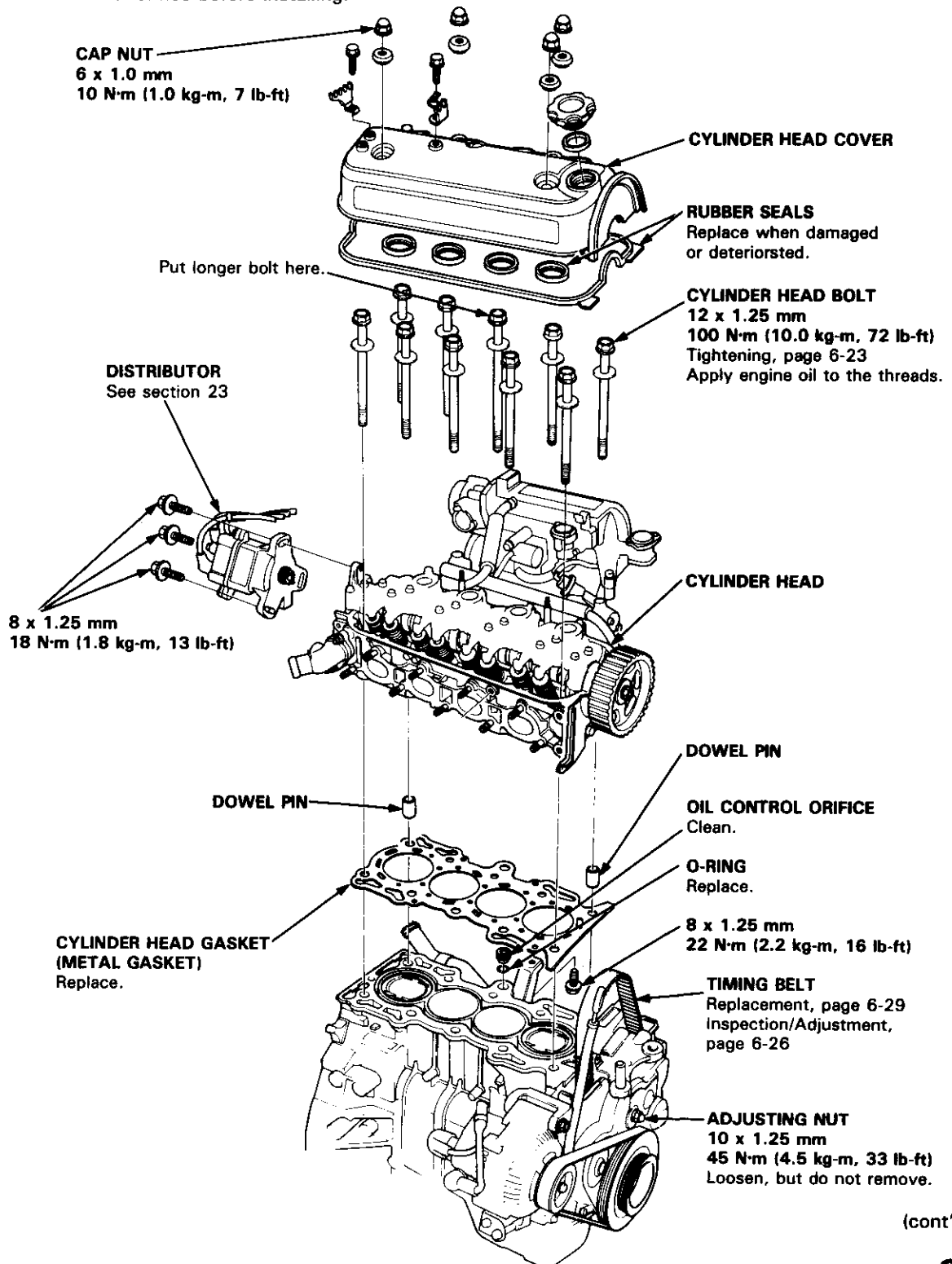

(cont'd)

Illustrated Index

(cont'd)

 Prior to reassembling, clean all the parts in solvent, dry them and apply lubricant to any contact parts.

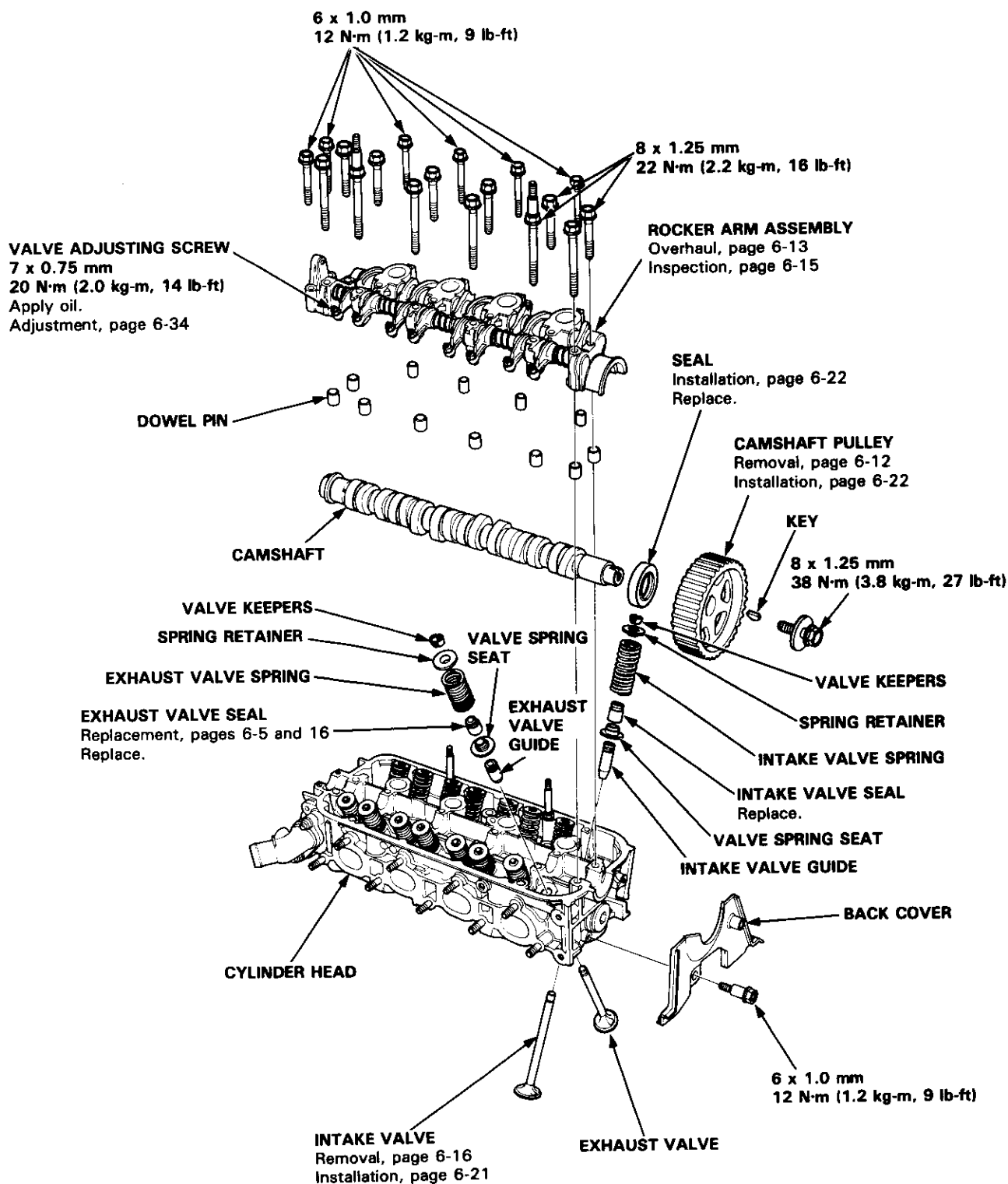



Valve Seals

Replacement (Cylinder head removal not required)

NOTE: Cylinder head removal is not required in this procedure.

The procedure shown below applies when using the in-car valve spring compressor. (Snap-on YA8845 with YA8845-2 A 7/8" attachment)

▲ WARNING Always wear approved eye protection when using the in-car valve spring compressor.

1. Turn the crankshaft so that the No. 1 and the No. 4 pistons are at top dead center (TDC).

2. Remove the cylinder head cover and the rocker arm assembly.

NOTE:

- Refer to page 6-12 for rocker arm assembly removal.
- When removing or installing the rocker arm assembly, do not remove the camshaft holder bolts. The bolts will keep the holders, springs and rocker arms on the shaft.

3. Remove the fuel injectors and the wire harness.

4. Using the 8 mm bolts supplied with the tool, mount the two uprights to the cylinder head at the end camshaft holders. The uprights fit over the camshaft as shown.

5. Insert the cross shaft through the top hole of the two uprights.

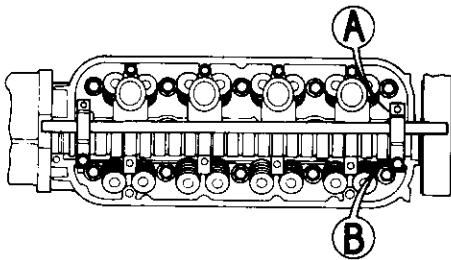

Intake Valve Seals:

6. Select the 7/8 in diameter long compressor attachment and fasten the attachment to the No. 5 hole of the lever arm with the speed pin supplied.

7. Insert an air adaptor into the spark plug hole. Pump air into the cylinder to keep the valve closed while compressing springs and removing the valve keepers.

8. Position the lever arm under the cross shaft so the lever is perpendicular to the shaft and the compressor attachment rests on top of the retainer for the spring being compressed. Use the front position slot on the lever as shown.

NOTE: Put shop towels over the oil passages to prevent the valve keepers from falling into the cylinder head.

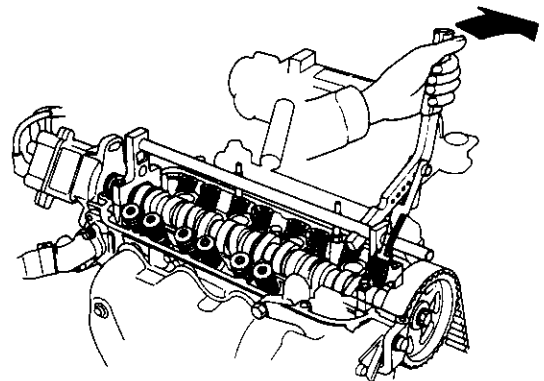
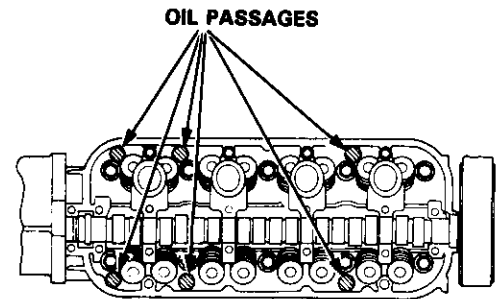

(cont'd)

Valve Seals

Replacement (Cylinder head removal not required) (cont'd)

9. Using a downward motion on the lever arm, compress the valve spring and remove the keepers from the valve stem. Slowly release pressure on the spring.
10. Remove the valve seals (page 6-16).
11. Install the valve seals (page 6-21).
12. Install the springs, the retainers and the keepers in reverse order of removal.

Exhaust Valve Seals:

13. Select the 7/8 in. diameter short compressor attachment and fasten the attachment to the No. 4 hole of the lever arm with the speed pin supplied.
14. Position the lever arm under the cross shaft so the lever is perpendicular to the shaft and the compressor attachment rests on top of the retainer for the spring being compressed. Use the front position slot on the lever as shown.

NOTE: Put shop towels over the oil passages to prevent the valve keepers from falling into the cylinder head.

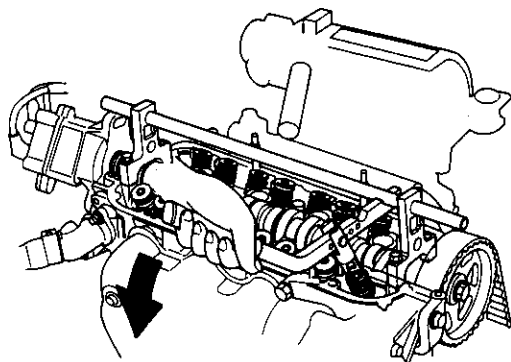

15. Using a downward motion on the lever arm, compress the valve spring and remove the keepers from the valve stem. Slowly release pressure on the spring.
16. Remove the valve seals (page 6-16).
17. Install the valve seals (page 6-21).
18. Install the springs, the retainers and the keepers in reverse order of removal.
19. Repeat steps 6 to 18 on the other cylinders.

Cylinder Head

Removal



Engine removal is not required for this procedure.

▲ WARNING

- Make sure jacks and safety stands are placed properly and hoist brackets are attached to correct positions on the engine.
- Make sure the car will not roll off stands and fall while you are working under it.

CAUTION:

- Use fender covers to avoid damaging painted surfaces.
- Unspecified items are common.
- Unplug the wiring connectors carefully while holding the connector portion to avoid damage.
- Mark all wiring and hoses to avoid misconnection. Also, be sure that they do not contact other wiring or hoses or interfere with other parts.
- To avoid damaging the cylinder head, wait until the engine coolant temperature drops below 100°F (38°C) before loosening the retaining bolt.
- Inspect the timing belt before removing the cylinder head.
- Turn the crankshaft pulley so that the No. 1 piston is at top dead center (page 6-28).
- Make all emission hoses before disconnecting them.

NOTE: The radio may have a coded theft protection circuit. Be sure to get the customer's code number before

- Disconnecting the battery.
- Removing the No. 43 (10A) fuse (In the under-hood fuse/relay box).
- Removing the radio.

After service, reconnect power to the radio and turn it on. When the word "CODE" is displayed, enter the customer's 5-digit code to restore radio operation.

1. Disconnect the negative terminal from the battery.
2. Drain the engine coolant (see section 10).
 - Remove the radiator cap to speed draining
3. Relieve the fuel pressure.

▲ WARNING

Do not smoke while working on fuel system, keep open flame or spark away from work area. Drain fuel only into an approved container.

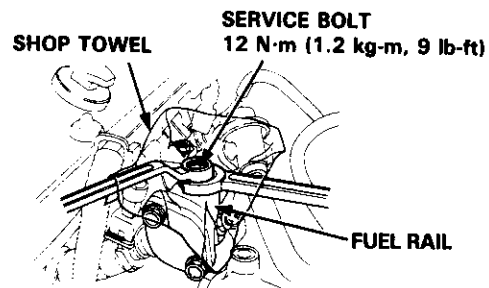

4. Remove the vacuum tube, breather hose and intake air duct.
5. Remove the water bypass hose from the cylinder head
6. Remove the fuel feed hose and evaporative emission (EVAP) control canister hose from the intake manifold.

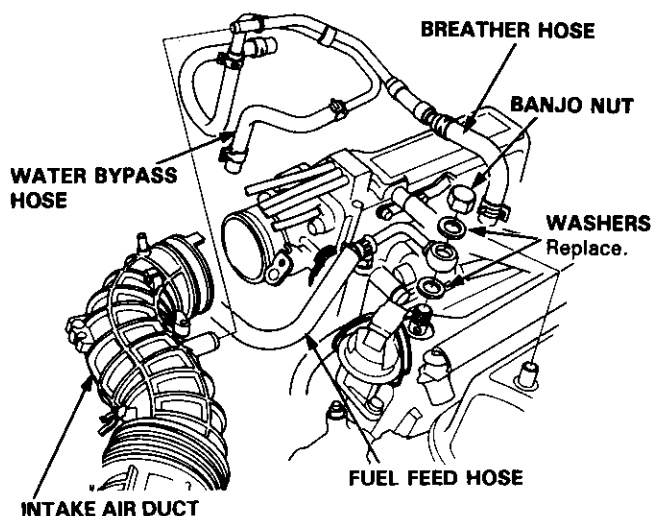

(cont'd)

Cylinder Head

Removal (cont'd)

7. Remove the brake booster vacuum hose and vacuum hose mount (A/T only) from the intake manifold.
8. Remove the fuel return hose and cruise control vacuum hose.

BRAKE BOOSTER VACUUM HOSE

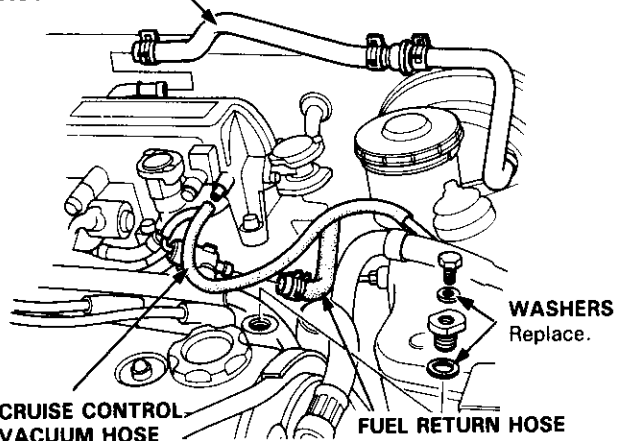

9. Remove the throttle cable and the throttle control cable (A/T only) from the throttle body.

NOTE:

- Take care not to bend the cable when removing it. Always replace any kinked cable with a new one.
- Adjust the throttle cable when installing (see section 11).

6 x 10 mm
12 N·m (1.2 kg-m, 9 lb-ft)

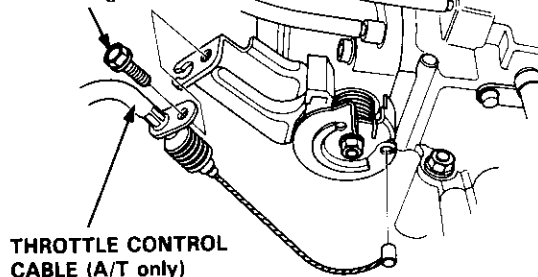

10. Remove the ignition coil.

☆ 8 x 1.25 mm
22 N·m (2.2 kg-m, 16 lb-ft)

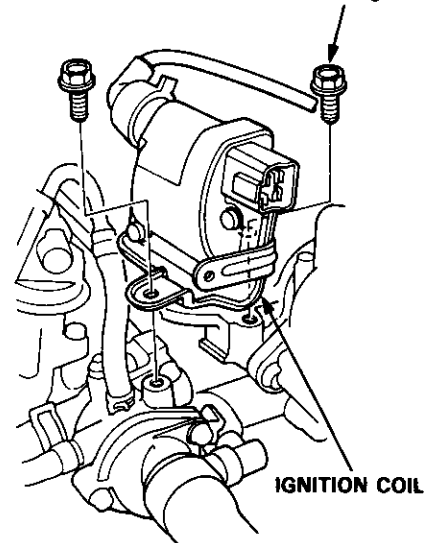

11. Remove the spark plug caps and the distributor.
12. Remove the connector and the terminal from the alternator, then remove the engine wire harness from the cylinder head cover.
13. Remove the following engine wire harness connectors and clamps from the cylinder head and the intake manifold:
 - Four fuel injector connectors
 - Intake air temperature (IAT) sensor connector
 - Idle air control (IAC) valve connector
 - Throttle position (TP) sensor connector
 - Exhaust gas recirculation (EGR) valve lift sensor connector
 - Ground cable terminals
 - Engine coolant temperature (ECT) switch B connector
 - Heated oxygen sensor (HO2S) connector
 - ECT sensor connector
 - ECT gauge sending unit connector
 - Ignition coil connector
 - CKP/TDC/CYP sensor connector
 - Vehicle speed sensor (VSS) connector
 - ECT switch A connector

☆: CORROSION RESISTANT BOLT



14. Remove the upper and lower radiator hoses and heater hoses.

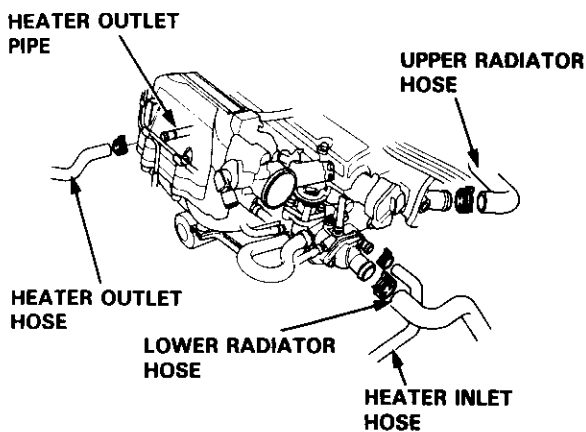

15. Remove the emission vacuum hoses and water bypass hoses from the intake manifold assembly.
16. Remove the water bypass hose from thermostat housing.
17. Remove the thermostat assembly from intake manifold.

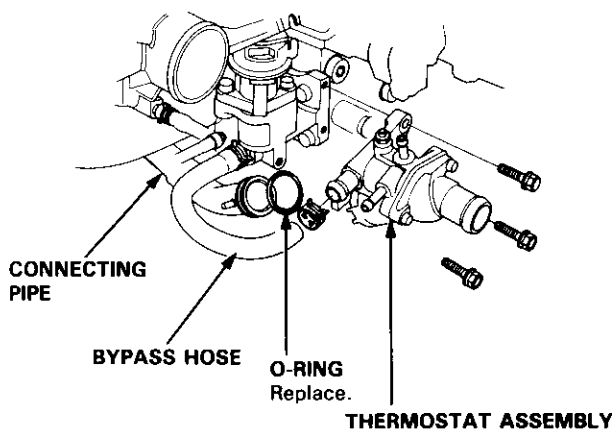

18. Disconnect the connector and vacuum tube, then remove the cruise control actuator

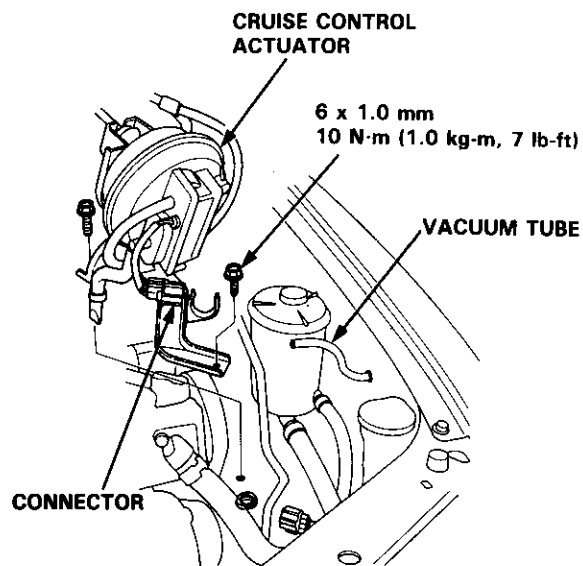

19. Remove the engine ground cable from the bodyside.
20. Remove the power steering (P/S) pump belt and pump.

NOTE:

- Do not disconnect the P/S hoses.
- After installing adjust the tension of the P/S pump belt (see section 17).

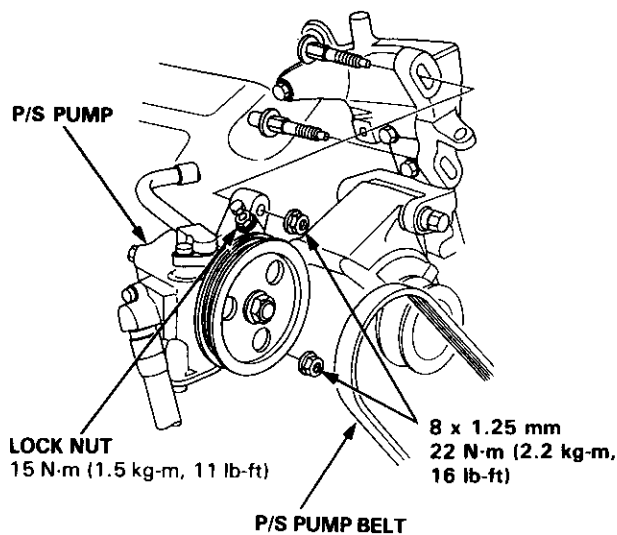

(cont'd)

Cylinder Head

Removal (cont'd)

21. Remove the intake manifold bracket and intake manifold.

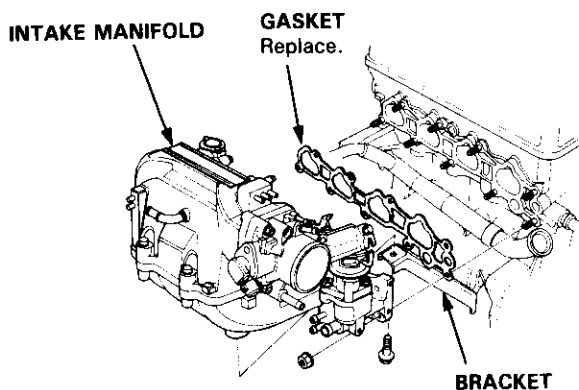

22. Lift the front of the car up and place it on safety stands.

▲ WARNING

- Make sure lifts, jacks and safety stands are placed properly, and hoist brackets are attached to the correct position on the engine (see page 1-10 thru 1-12).
- Apply parking brake and block rear wheels, so car will not roll off stands and fall on you while working under it.

23. Remove the front wheels and the engine splash shield (page 5-18).

24. Remove the heat insulator (cars equipped with air conditioning only).

25. Remove the self-locking nuts and disconnect the exhaust manifold and exhaust pipe A.

26. Remove the exhaust manifold bracket and exhaust manifold.

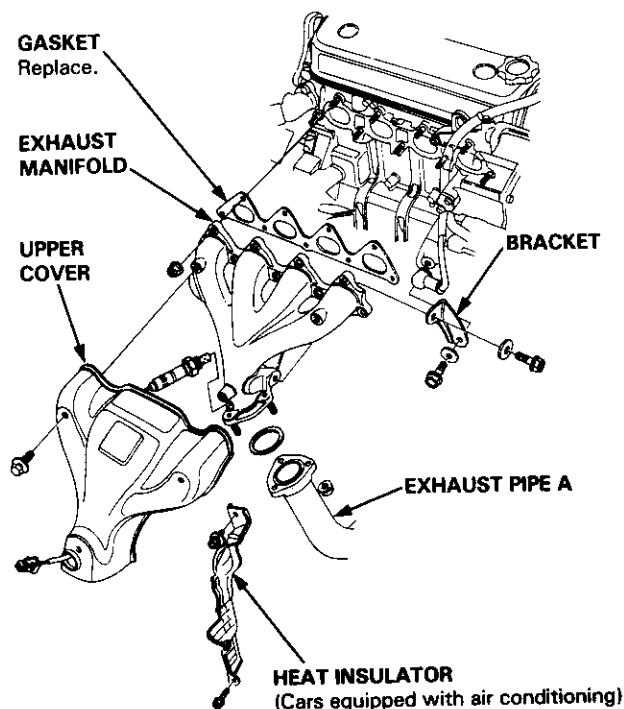

27. Remove the positive crankcase ventilation (PCV) hose, then remove the cylinder head cover.

28. Remove the upper cover.

29. Loosen the adjusting nut 270 – 360°.

30. Push the tensioner to release tension from the timing belt, then retighten the adjusting nut.

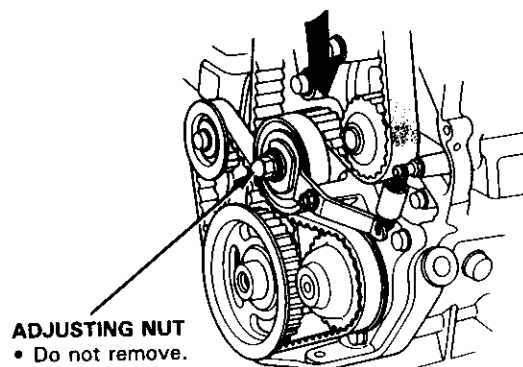



31. Remove the timing belt from the camshaft pulley.

CAUTION: Do not crimp or bend the timing belt more than 90° or less than 25 mm (1 in) in diameter.

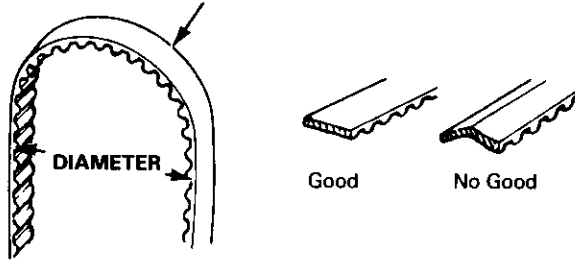

NOTE: Separate the cylinder head from the block with a flat blade screwdriver as shown.

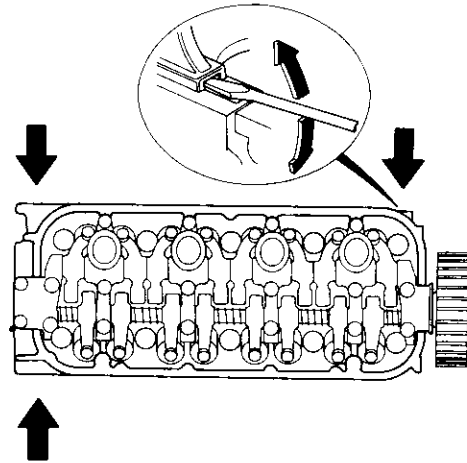

32. Remove the cylinder head bolts, then remove the cylinder head.

CAUTION: To prevent warpage, unscrew the bolts in sequence 1/3 turn at a time; repeat until all bolts are loosened.

CYLINDER HEAD BOLT LOOSENING SEQUENCE

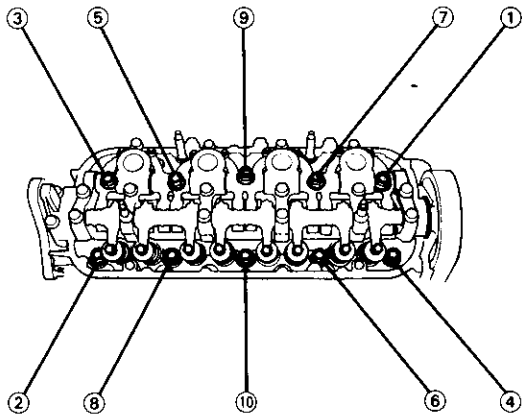

Camshaft Pulley

Removal

1. To ease reassembly, turn the camshaft pulley until the "UP" mark faces up, and the front timing mark is aligned with the cylinder head upper surface.

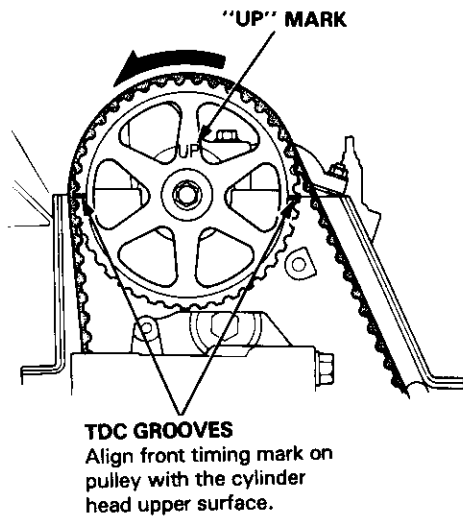

2. Remove the timing belt.
3. Remove the retaining bolt, the special washer, the camshaft pulley and the key, then remove the back cover.

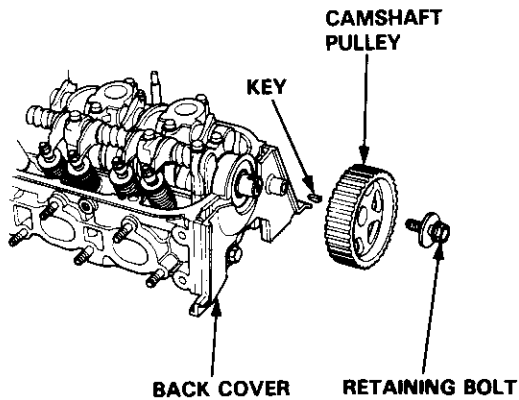

Rocker Arm Assembly

Removal

1. Loosen the adjusting screws, then remove the bolts and the rocker arm assembly.

NOTE:

- Unscrew the camshaft holder bolts two turns at a time, in a crisscross pattern to prevent damaging the valves or rocker arm assembly.
- When removing the rocker arm assembly, do not remove the camshaft holder bolts. The bolts will keep the camshaft holders, the springs and the rocker arms on the shafts.

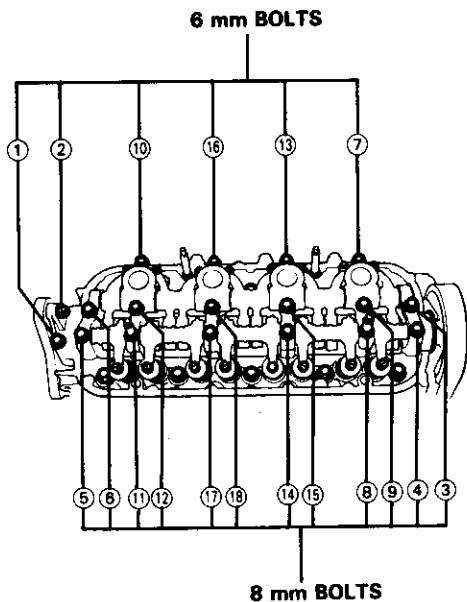
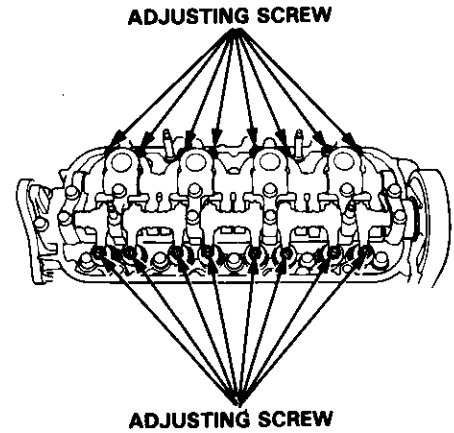



Rocker Arms

Overhaul

NOTE:

- Identify parts as they are removed to ensure reinstallation in original locations.
- Inspect rocker shafts and rocker arms (page 6-15).
- Rocker arms must be installed in the same position if reused.
- When removing or installing rocker arm assembly, do not remove the camshaft holder bolts. The bolts will keep the holders, springs and rocker arms on the shaft.
- When reassembling, fit the projection of the intake rocker shaft to the notch in the camshaft holder.



Prior to reassembling, clean all the part in solvent, dry them and apply lubricant to any contact parts.

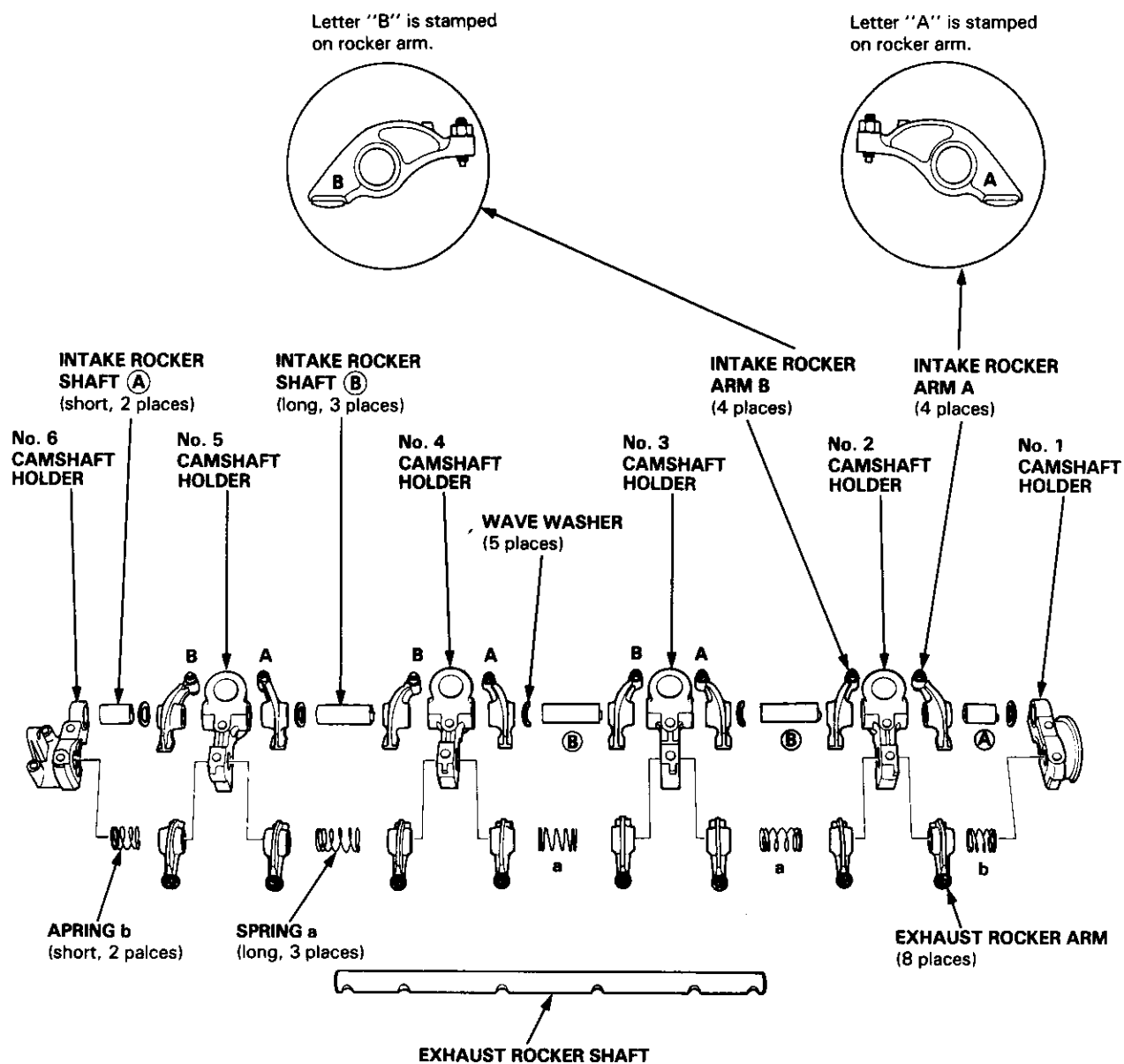

Camshaft Inspection

Note:

- Do not rotate the camshaft during inspection.
- Remove the rocker arms and rocker shafts.

1. Put the camshaft and the camshaft holders on the cylinder head, then tighten the bolts to the specified torque.

Specified torque:

8 mm bolts: 22 N·m (2.2 kg-m, 16 lb-ft)

6 mm bolts: 12 N·m (1.2 kg-m, 9 lb-ft)

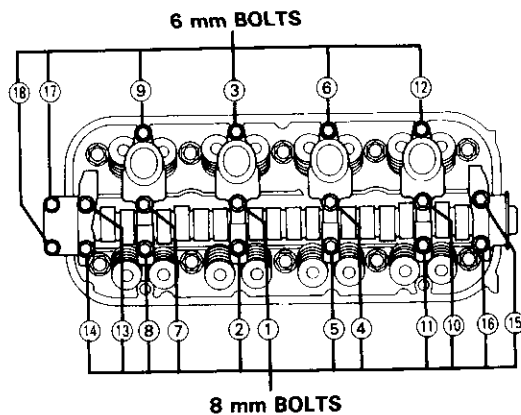

2. Seat the camshaft by pushing it toward distributor end of cylinder head.
3. Zero the dial indicator against end of distributor drive, then push the camshaft back and forth and read the end play.

Camshaft End Play:

Standard (New): 0.05–0.15 mm
(0.002–0.006 in)

Service Limit: 0.5 mm (0.02 in)

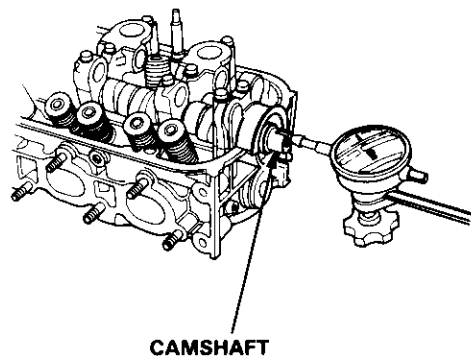

4. Remove the bolts, then remove the camshaft holders from the cylinder head.

– Lift camshaft out of cylinder head, wipe clean, then inspect lift ramps. Replace camshaft if lobes are pitted, scored, or excessively worn.

– Clean the camshaft bearing surfaces in the cylinder head, then set camshaft back in place.

– Insert plastigage strip across each journal.

5. Install the camshaft holders, then tighten the bolts to the specified torque as shown in the left column on this page.

6. Measure widest portion of plastigage on each journal.

Camshaft-to-Holder Oil Clearance:

Standard (New): 0.050–0.089 mm
(0.0020–0.0035 in)

Service Limit: 0.15 mm (0.006 in)

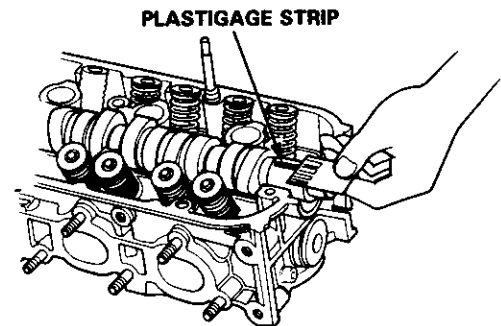



Rocker Arms

Clearance

Measure both the intake rocker shafts and exhaust rocker shaft.

1. Measure diameter of the shaft at the first rocker location.

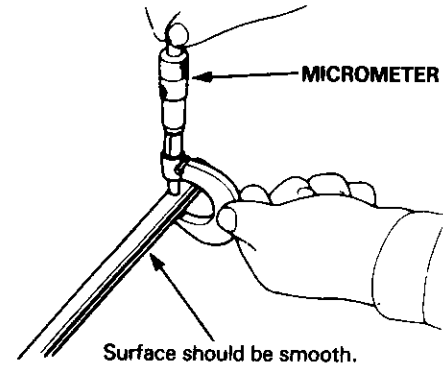

2. Zero the gauge to the shaft diameter.

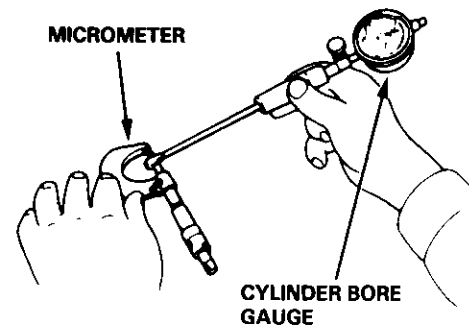

3. Measure the inside diameter of the rocker arm and check for out-of-round condition.

Rocker Arm-to-Shaft Clearance: Standard(New)

Intake: 0.017–0.050 mm
(0.0007–0.0020 in)

Exhaust: 0.018–0.054 mm
(0.0007–0.0021 in)

Service Limit: 0.08 mm
(0.003 in)

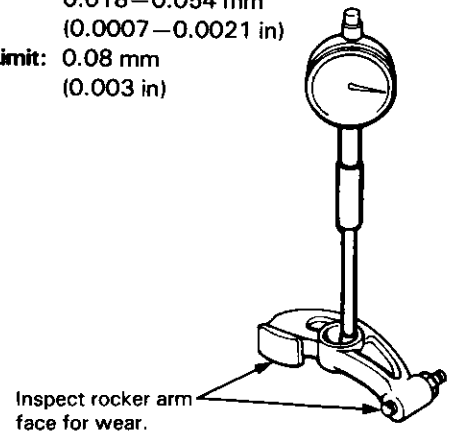

Repeat for all rockers. If over limit, replace the rocker shaft and all over-tolerance rocker arms.

7. If camshaft-to-holder oil clearance is out of tolerance:

- And the camshaft has already been replaced, you must replace the cylinder head.
- If camshaft has not been replaced, first check total runout with the camshaft supported on V-blocks.

Camshaft Total Runout:

Standard(New): 0.03 mm (0.001 in) max.

Service Limit: 0.06 mm (0.002 in)

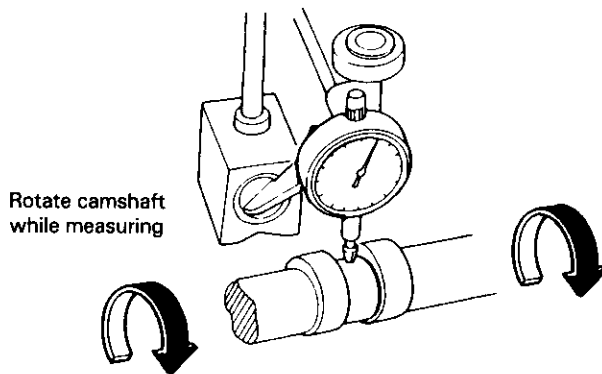

- If the total runout of the camshaft is within tolerance, replace the cylinder head.
- If the total runout is out of tolerance, replace the camshaft and recheck. If the oil clearance is still out of tolerance, replace the cylinder head.

8. Measure cam lobe height.

Cam Lobe Height:

Intake Standard: 38.526 mm (1.5168 in)

Exhaust Standard: 38.778 mm (1.5267 in)

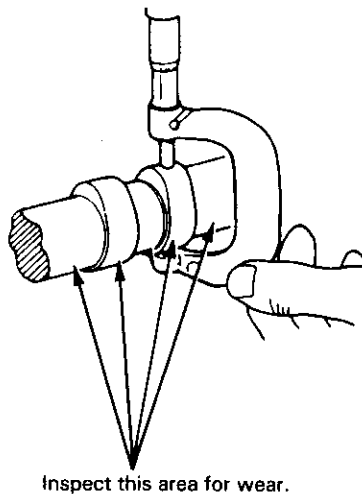

Valves, Valve Springs and Valve Seals

Removal

NOTE: Identify valves and valve springs as they are removed so that each item can be reinstalled in its original position.

1. Tap each valve stem with a plastic mallet to loosen valve keepers before installing the spring compressor.
2. Install the spring compressor. Compress the spring and remove the valve keepers.

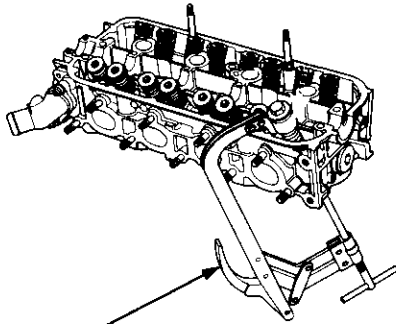

VALVE SPRING COMPRESSOR
COMMERCIALY AVAILABLE

3. Install the special tool as shown.

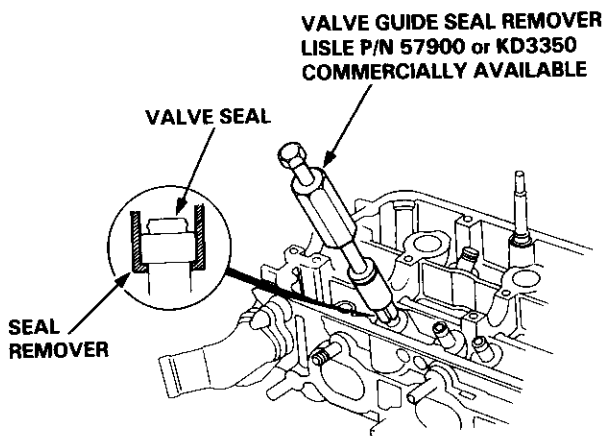

4. Remove the valve seal.

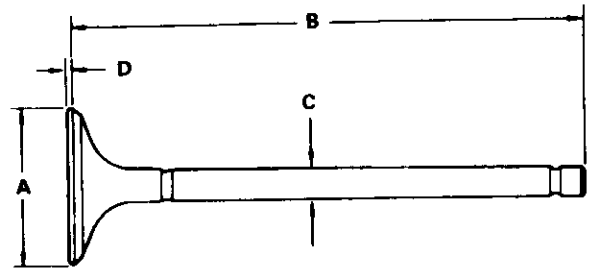
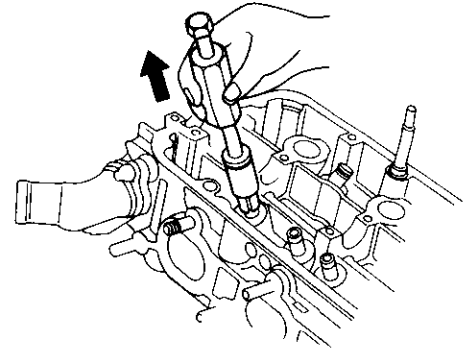

Intake Valve Dimensions

A Standard(New): 33.90–34.10 mm
(1.335–1.343 in)

B Standard(New): 110.88–111.18 mm
(4.365–4.377 in)

C Standard(New): 5.485–5.495 mm
(0.2159–0.2163 in)

C Service Limit: 5.455 mm (0.2148 in)

D Standard(New): 0.85–1.15 mm
(0.033–0.045 in)

D Service Limit: 0.65 mm (0.026 in)

Exhaust Valve Dimensions

A Standard(New): 28.90–29.10 mm
(1.138–1.146 in)

B Standard(New): 122.15–122.45 mm
(4.809–4.821 in)

C Standard(New): 5.450–5.460 mm
(0.2146–0.2150 in)

C Service Limit: 5.420 mm (0.2134 in)

D Standard(New): 1.05–1.35 mm
(0.041–0.053 in)

D Service Limit: 0.95 mm (0.037 in)

Valve Seats

Reconditioning



1. Renew the valve seats in the cylinder head using a valve seat cutter.

NOTE: If guides are worn (page 6-18), replace them (page 6-19) before cutting the valve seats.

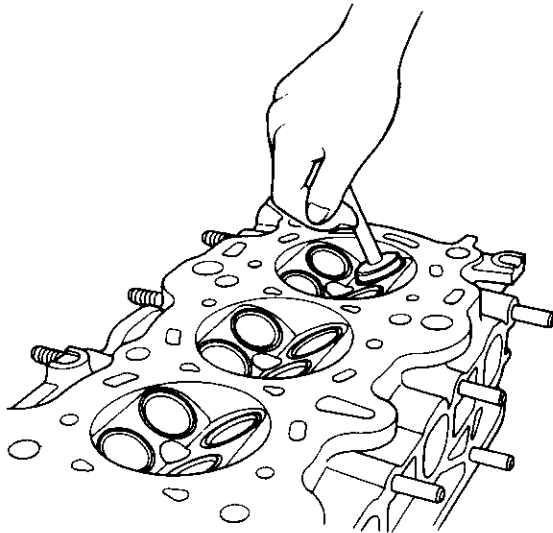

2. Carefully cut a 45° seat, removing only enough material to ensure a smooth and concentric seat.
3. Bevel the upper edge of the seat with the 30° cutter and the lower edge of the seat with the 60° cutter. Check width of seat and adjust accordingly.
4. Make one more very light pass with the 45° cutter to remove any possible burrs caused by the other cutter.

Valve Seat Width:

Standard (New): 1.25–1.55 mm

(0.049–0.061 in)

Service Limit: 2.00 mm (0.079 in)

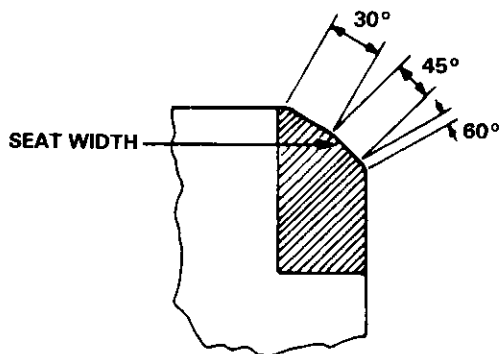

5. After resurfacing the seat, inspect for even valve seating: Apply Prussian Blue compound to the valve face, and insert valve in original location in the head, then lift it and snap it closed against the seat several times.

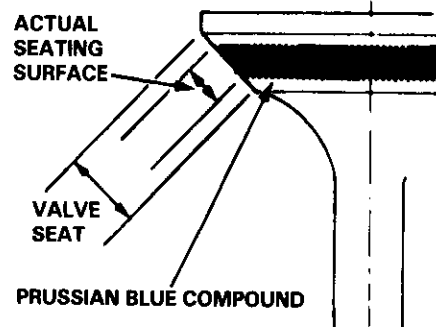

6. The actual valve seating surface, as shown by the blue compound, should be centered on the seat.
 - If it is too high (closer to the valve stem), you must make a second cut with the 60° cutter to move it down, then one more cut with the 45° cutter to restore seat width.
 - If it is too low (closer to the valve edge), you must make a second cut with the 30° cutter to move it up, then one more cut with the 45° cutter to restore seat width.
7. Insert intake and exhaust valves in the head and measure valve stem installed height.

Intake Valve Stem Installed Height:

Standard (New): 48.245–48.715 mm
(1.8994–1.9179 in)

Service Limit: 48.965 mm (1.9278 in)

Exhaust Valve Stem Installed Height:

Standard (New): 50.315–50.785 mm
(1.9809–1.9994 in)

Service Limit: 51.035 mm (2.0092 in)

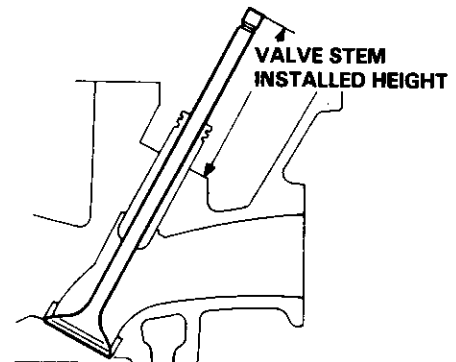

8. If valve stem installed height is over the service limit, replace the valve and recheck. If still over the service limit, replace the cylinder head; the valve seat in the head is too deep.

Cylinder Head

Warpage

NOTE: If camshaft-to-holder oil clearance (page 6-14) are not within specification, the cylinder head cannot be resurfaced.

If camshaft-to-holder oil clearances are within specifications, check the cylinder head for warpage.

- If warpage is less than 0.05 mm (0.002 in) cylinder head resurfacing is not required.
- If warpage is between 0.05 mm (0.002 in) and 0.2 mm (0.008 in), resurface cylinder head.
- Maximum resurface limit is 0.2 mm (0.008 in) based on a height of 100 mm (3.94 in).

PRECISION STRAIGHT EDGE

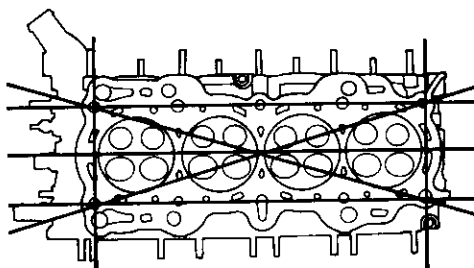
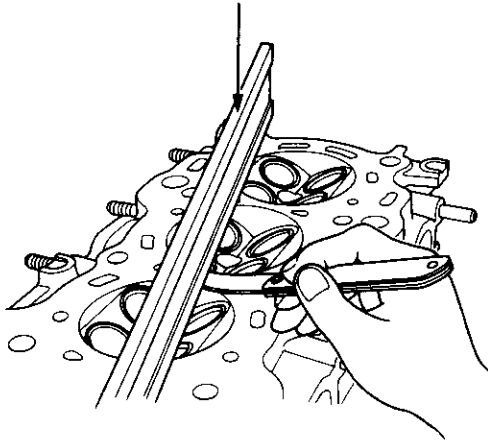

Measure along edges, and 3 ways across center.

Cylinder Head Height:

Standard (New): 99.95–100.05 mm
(3.935–3.939 in)

Valve Guides

Valve Movement

Measure the guide-to-stem clearance with a dial indicator while rocking the stem in the direction of normal thrust (wobble method).

Intake Valve Stem-to-Guide Clearance:

Standard (New): 0.04–0.09 mm
(0.002–0.004 in)

Service Limit: 0.16 mm (0.006 in)

Exhaust Valve Stem-to-Guide Clearance:

Standard (New): 0.11–0.16 mm
(0.004–0.006 in)

Service Limit: 0.24 mm (0.009 in)

Valve extended 10 mm out from seat.

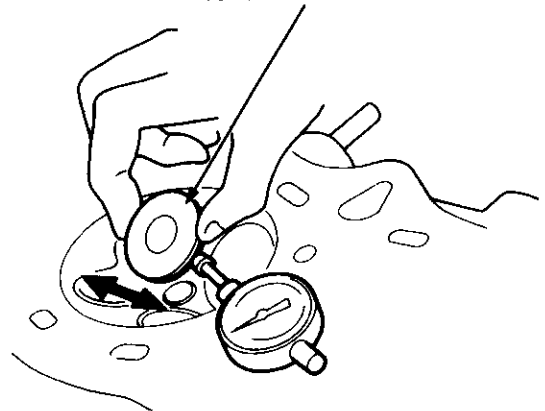

- If measurement exceeds the service limit, recheck using a new valve.
- If measurement is now within service limit, reassemble using a new valve.
- If measurement still exceeds limit, recheck using alternate method below, then replace valve and guide, if necessary.

NOTE: An alternate method of checking guide to stem clearance is to subtract the O.D. of the valve stem, measured with a micrometer, from the I.D. of the valve guide, measured with an inside micrometer or ball gauge.

Take the measurements in three places along the valve stem and three places inside the valve guide.

The difference between the largest guide measurement and the smallest stem measurement should not exceed the service limit.

Intake Valve Stem-to-Guide Clearance:

Standard (New): 0.020–0.045 mm
(0.0008–0.0018 in)

Service Limit: 0.08 mm (0.003 in)

Exhaust Valve Stem-to-Guide Clearance:

Standard (New): 0.055–0.080 mm
(0.0022–0.0031 in)

Service Limit: 0.12 mm (0.005 in)



Replacement

1. As illustrated in the removal steps of this procedure, use a commercially—available air-impact driver attachment modified to fit the diameter of the valve guides. In most cases, the same procedure can be done using the Valve Guide Driver and a conventional hammer.

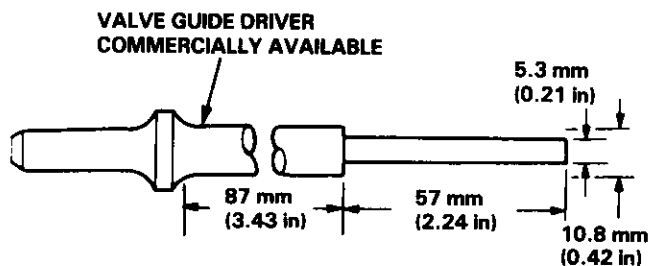

Removal and installation
VALVE GUIDE DRIVER, 5.5 mm
07742-0010100

2. Select the proper replacement guides and chill them in the freezer section of a refrigerator for about an hour.
3. Use a hot plate or oven to evenly heat the cylinder head to 300°F (150°C). Monitor the temperature with a cooking thermometer.

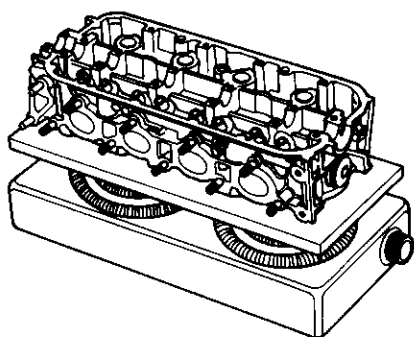

CAUTION:

- Do not use a torch; it may warp the head.
- Do not get the head hotter than 300°F (150°C); excessive heat may loosen the valve seats.
- To avoid burns, use heavy gloves when handling the heated cylinder head.

4. Working from the camshaft side. Use the driver and an air hammer to drive the guide about 2 mm (0.1 in) towards the combustion chamber. This will knock off some of the carbon and make removal easier.

CAUTION:

- Always wear safety goggles or a face shield when using the air hammer.
- Hold the air hammer directly in line with the valve guide to prevent damaging the driver.

5. Turn the head over and drive the guide out toward the camshaft side of head.

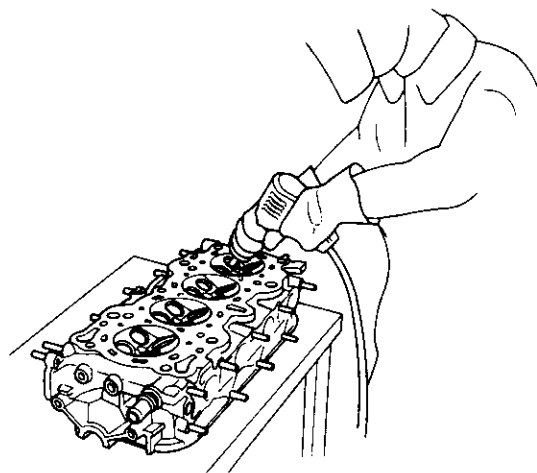

VALVE GUIDE DRIVER
COMMERCIALY AVAILABLE

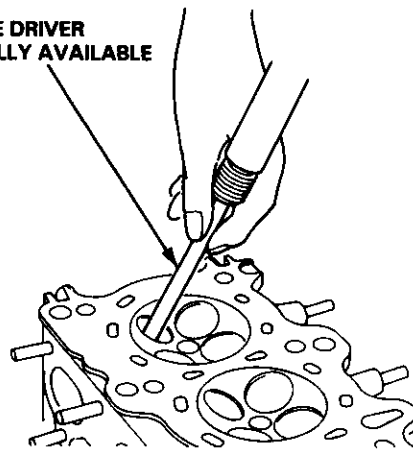

If a valve guide still won't move, drill it out with a 8 mm (5/16 inch) bit, then try again.

CAUTION: Drill guides only in extreme cases; you could damage the cylinder head if the guide breaks.

6. Remove the new guide(s) from the refrigerator, one at a time, as you need them.

(cont'd)

Valve Guides

Replacement (cont'd)

- Slip a 6 mm (0.2 in) steel washer and the correct driver attachment over the end of the driver (The washer will absorb some of the impact and extend the life of the driver).

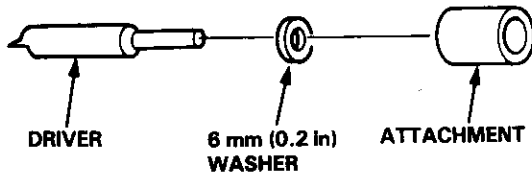

- Install the new guide(s) from the camshaft side of the head; drive each one in until the attachment bottoms on the head. If you have all sixteen guides to do, you may have to reheat the head one or two more times.

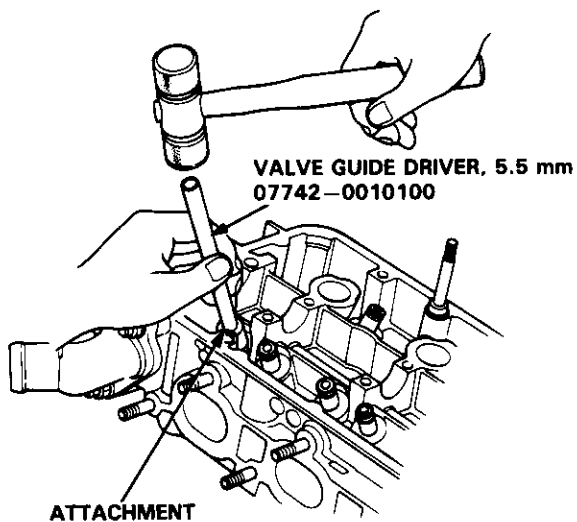

Valve Guide Installed Height:

Intake: 23.75–24.25 mm (0.915–0.947 in)

Exhaust: 15.05–15.55 mm (0.593–0.612 in)

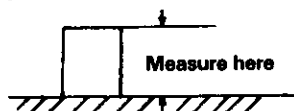

Reaming

NOTE: For new valve guides only.

- Coat both reamer and valve guide with cutting oil.
- Rotate the reamer clockwise the full length of the valve guide bore.
- Continue to rotate the reamer clockwise while removing it from the bore.
- Thoroughly wash the guide in detergent and water to remove any cutting residue.
- Check clearance with a valve (page 6-18).
 - Verify that the valve slides in the intake and exhaust valve guides without exerting pressure.

VALVE GUIDE REAMER,
5.5 mm
07HAH-PJ7010A or
07HAH-PJ7010B

REAMER HANDLE

Turn reamer in
clockwise direction only.

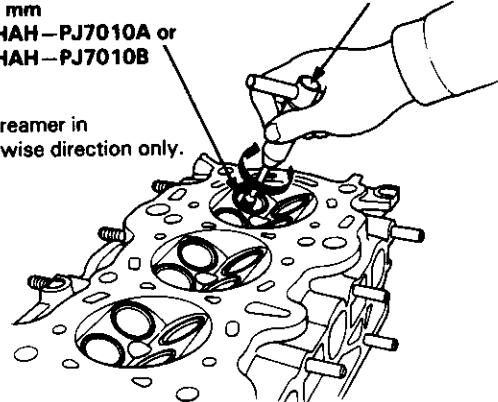



Valves, Valve Springs and Valve Seals

Valve Spring and Valve Seal Installation Sequence

NOTE: Exhaust and intake valve seals are NOT interchangeable.

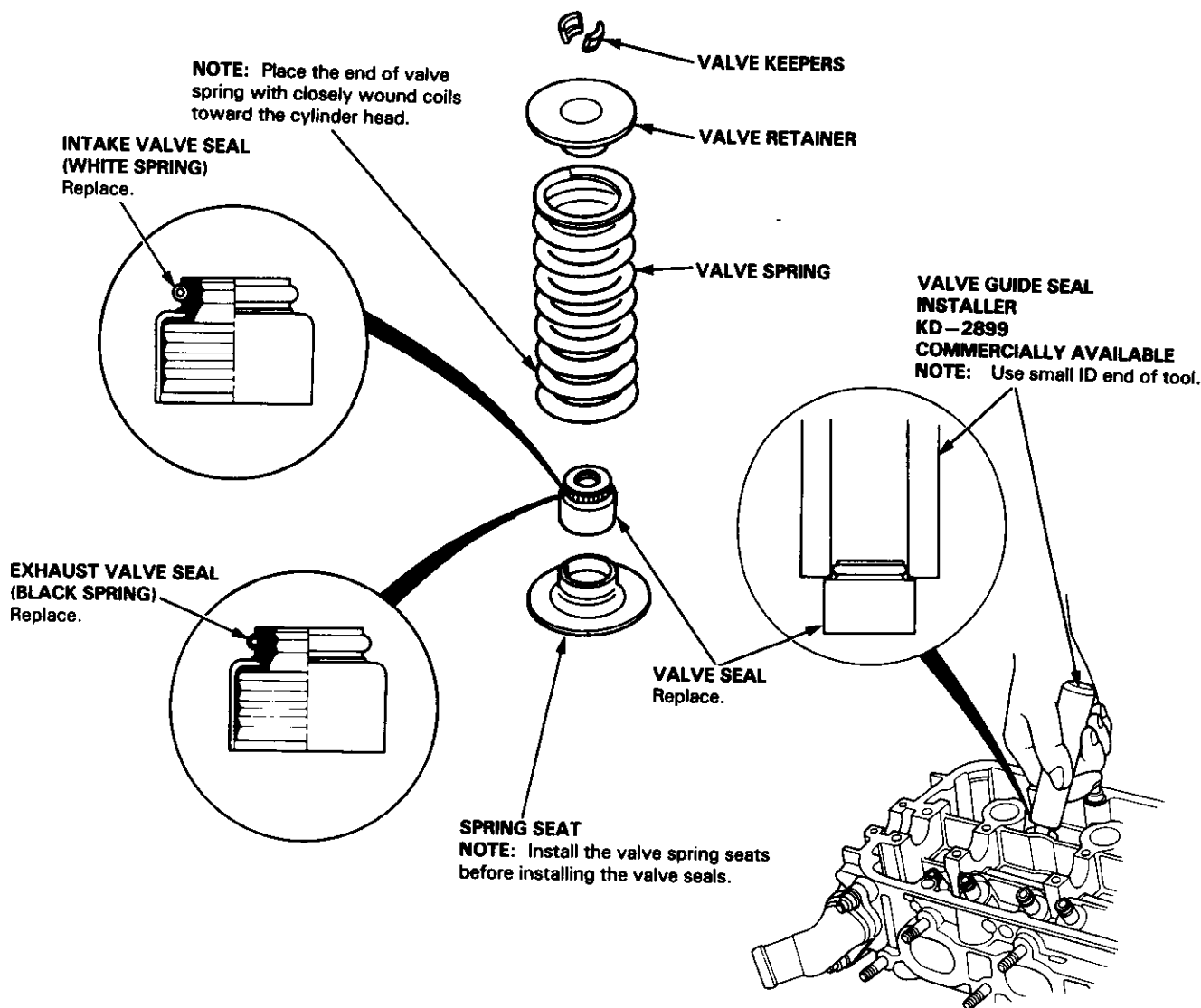

Valve Installation

When installing valves in cylinder head, coat valve stems with oil before inserting into valve guides, and make sure valves move up and down smoothly.

When valves and springs are in place, lightly tap the end of each valve stem two or three times with a plastic mallet to ensure proper seating of valve and valve keepers.

NOTE: Tap the valve stem only along its axis so you do not bend the stem.

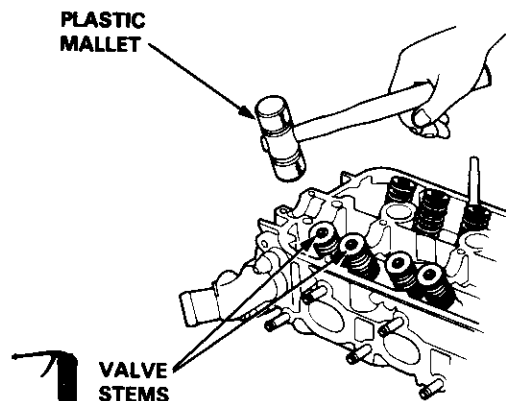

Camshaft/Rocker Arms and Camshaft Seals/Pulley

Installation

CAUTION:

- Make sure that all rockers are in alignment with valves when torquing rocker assembly bolts.
- Valve locknuts should be loosened and adjust screws backed off before installation.
- To prevent rocker arm assembly from coming apart, leave bearing cap holding bolts in the holes.

1. After wiping down the camshaft and journals in cylinder head, lubricate both surfaces and install camshaft.

 Lubricate cam lobes after reassembly.

2. Turn the camshaft until its keyway is facing up. (No.1 cylinder TDC).
3. Apply liquid gasket to the head mating surfaces of the No. 1 and No. 6 camshaft holders.
 - Apply liquid gasket to the shaded areas.

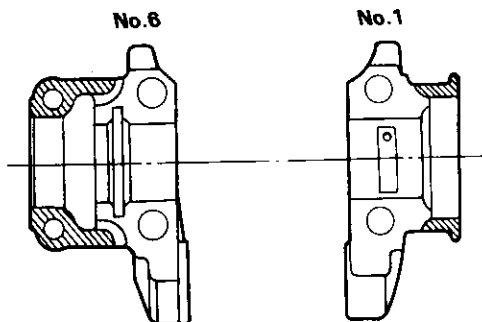

4. Set the rocker arm assembly in place and loosely install the bolts.
 - Make sure that the rocker arms are properly positioned on the valve stems.
5. Install the camshaft oil seal using the special tools as shown.

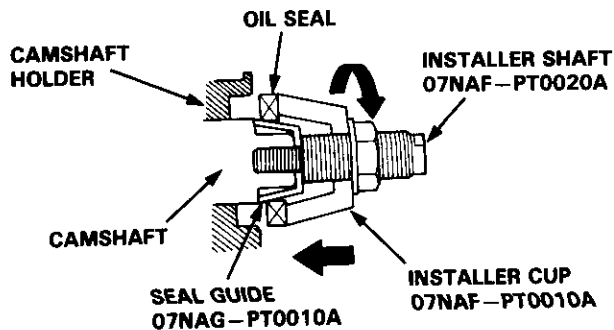
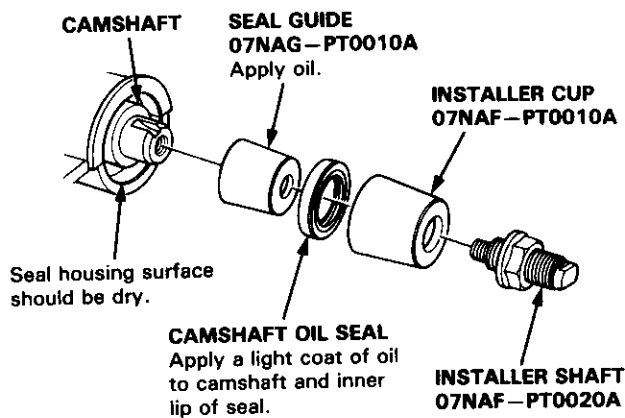

6. Tighten each bolt two turns at a time in the sequence shown below to ensure that the rockers do not bind on the valves.

Specified torque:

8 mm bolts: 22 N·m (2.2 kg-m, 16 lb-ft)

6 mm bolts: 12 N·m (1.2 kg-m, 9 lb-ft)

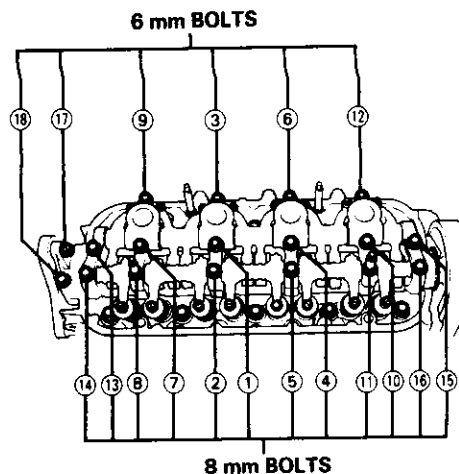

7. Install the back cover.
8. Install the key and the camshaft pulley onto the camshaft, then tighten the retaining bolt to the torque shown.

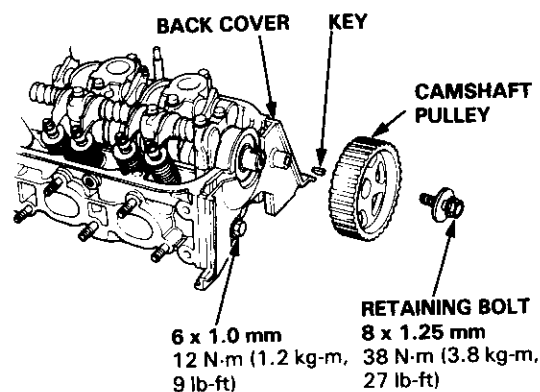



Cylinder Head

Installation

Install the cylinder head in the reverse order of removal:

NOTE:

- Always use a new head gasket.
- Cylinder head and engine block surface must be clean.
- "UP" mark on camshaft pulley should be at the top.
- Turn the crankshaft so the No. 1 cylinder is at TDC (page 6-28).
- Clean the oil control orifice before installing.

1. Cylinder head dowel pins and oil control orifice must be aligned.

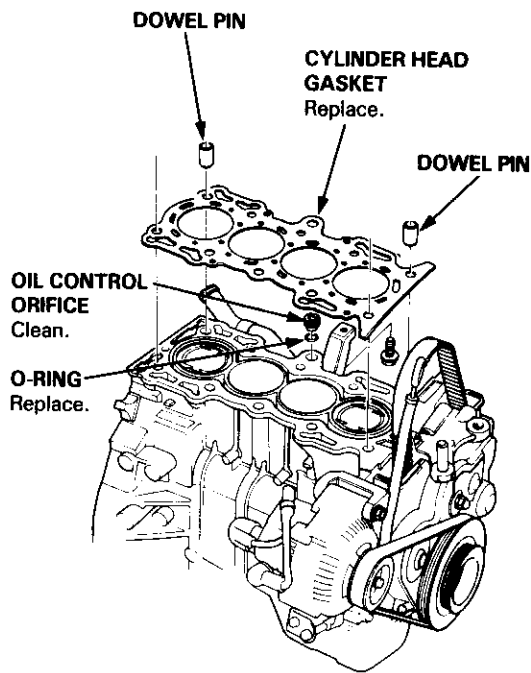

2. Install the bolts that secure the intake manifold to its bracket but do not tighten them yet.
3. Position the camshaft correctly (page 6-28).
4. Tighten the cylinder head bolts sequentially in three steps.

1st step torque: 40 N·m (4.0 kg-m, 29 lb-ft)

2nd step torque: 70 N·m (7.0 kg-m, 51 lb-ft)

3rd step torque: 100 N·m (10.0 kg-m, 72 lb-ft)

NOTE:

- We recommend using a beam-type torque wrench. When using a preset-type torque wrench, be sure to tighten slowly and not to overtighten.
- If a bolt makes any noise while you are torquing it, loosen the bolt and retighten it from the 1st step.

CYLINDER HEAD BOLTS TORQUE SEQUENCE

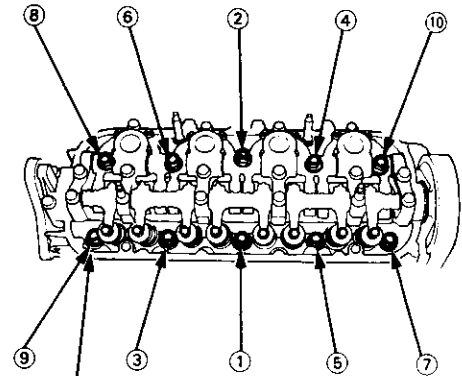

CYLINDER HEAD BOLTS

12 x 1.25 mm

100 N·m (10.0 kg-m, 72 lb-ft)

Apply clean engine oil to bolt threads and under bolt heads.

(cont'd)

Cylinder Head

Installation (cont'd)

5. Install the intake manifold and tighten the nuts in a crisscross pattern in 2 or 3 steps, beginning with the inner nuts.
- Always use a new intake manifold gasket.

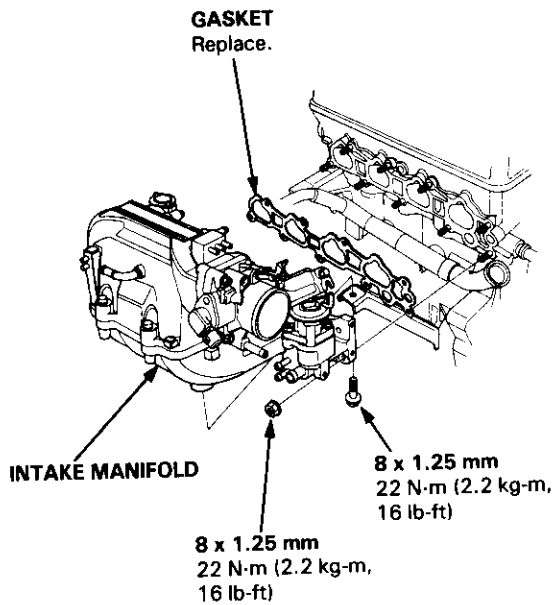

6. Install the heat insulator to the cylinder head and the block.

7. Install the exhaust manifold and tighten the nuts in a crisscross pattern in 2 or 3 steps, beginning with the inner nut.
- Always use a new exhaust manifold gasket.
8. Install the exhaust manifold bracket, then install the exhaust pipe A and the bracket, and then install the cover.

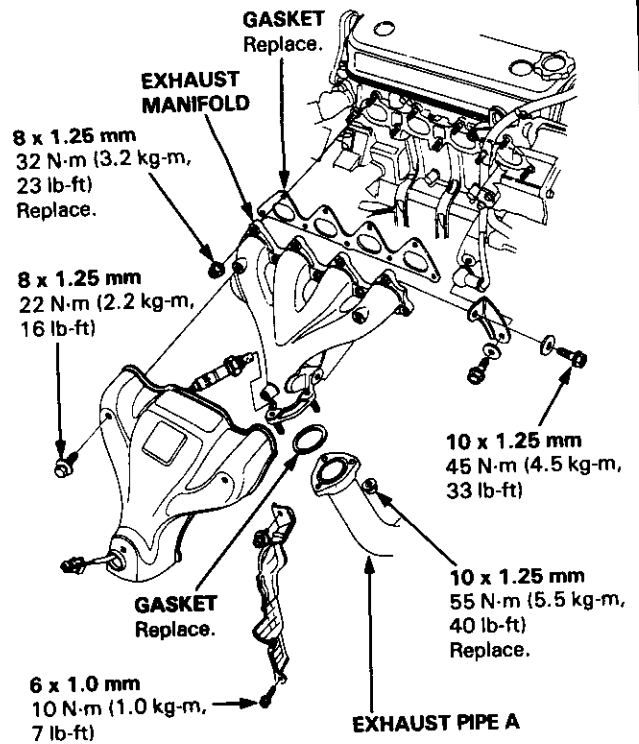



Timing Belt and Timing Balancer Belt

Illustrated Index

NOTE:

- Refer to page 6-28 for positioning crankshaft and pulley before installing timing belt.
- Before removing, mark direction of rotation.

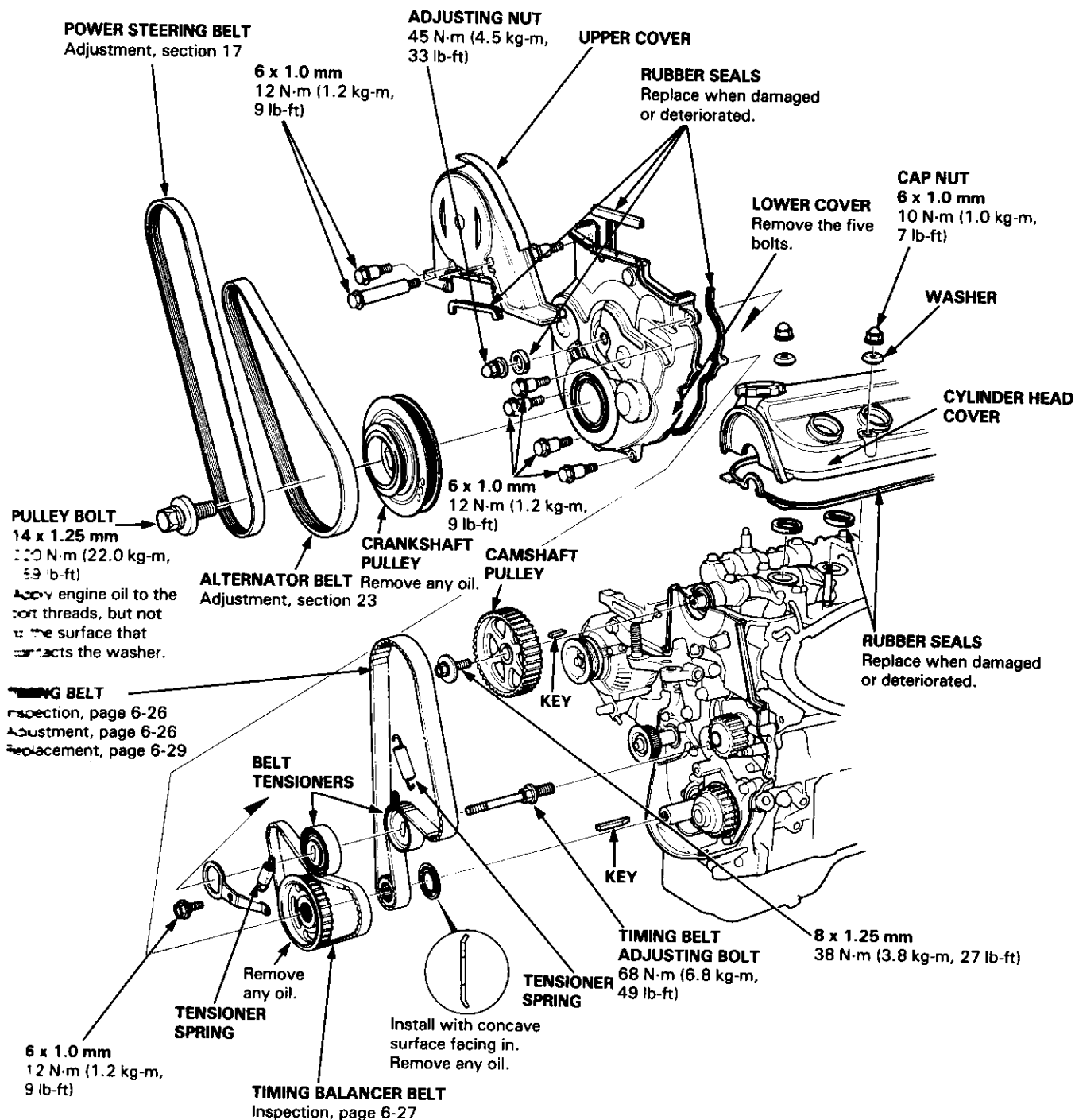

Timing Belt

Inspection

1. Disconnect the alternator terminal and the connector, then remove the engine wire harness from the cylinder head cover.
2. Remove the cylinder head cover.
3. Remove the upper cover.
4. Inspect the timing belt for cracks and oil or coolant soaking.

NOTE:

- Replace the belt if oil or coolant soaked.
- Remove any oil or solvent that gets on the belt.

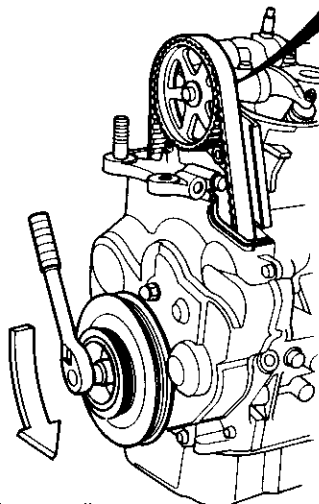
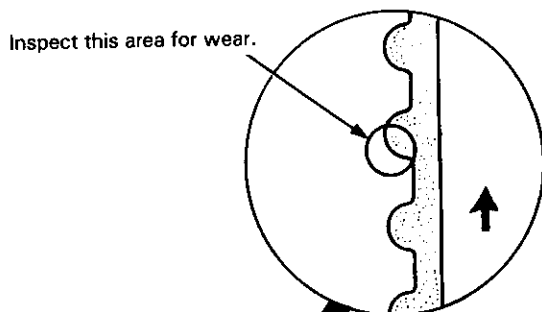

Rotate pulley
and inspect belt.

5. After inspecting, retorque the crankshaft pulley bolt to 220 N·m (22.0 kg·m, 159 lb·ft).

Tension Adjustment

CAUTION: Always adjust timing belt tension with the engine cold.

NOTE:

- The tensioner is spring-loaded to apply proper tension to the belt automatically after making the following adjustment.
- Always rotate the crankshaft counterclockwise when viewed from the pulley side. Rotating it clockwise may result in improper adjustment of the belt tension.
- Inspect the timing balancer belt before adjusting the belt tension.
- Do not loosen the adjusting nut more than one full turn.

1. Disconnect the alternator terminal and the connector, then remove the engine wire harness from the cylinder head cover.
2. Remove the cylinder head cover.
3. Set the No. 1 piston at TDC (page 6-28).
4. Loosen the adjusting nut 2/3-1 turn, then tighten it.

ADJUSTING NUT
45 N·m (4.5 kg·m, 33 lb·ft)

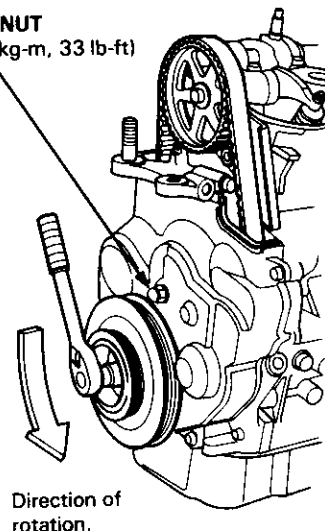

5. Rotate the crankshaft counterclockwise 3-teeth on the camshaft pulley, then reloosen the adjusting nut to create tension on the timing belt.
6. Tighten the adjusting nut.
7. After adjusting, retorque the crankshaft pulley bolt to 220 N·m (22.0 kg·m, 159 lb·ft).



Timing Balancer Belt

Inspection

1. Disconnect the alternator terminal and the connector, then remove the engine wire harness from the cylinder head cover.
2. Remove the cylinder head cover.
3. Remove the upper cover.
4. Remove the crankshaft pulley.
5. Remove the lower cover.
6. Install the crankshaft pulley.
7. Inspect the timing balancer belt for cracks and oil or coolant soaking.

NOTE:

- Replace the belt if oil or coolant soaked.
- Remove any oil or solvent that gets on the belt.

Inspect this area for wear.

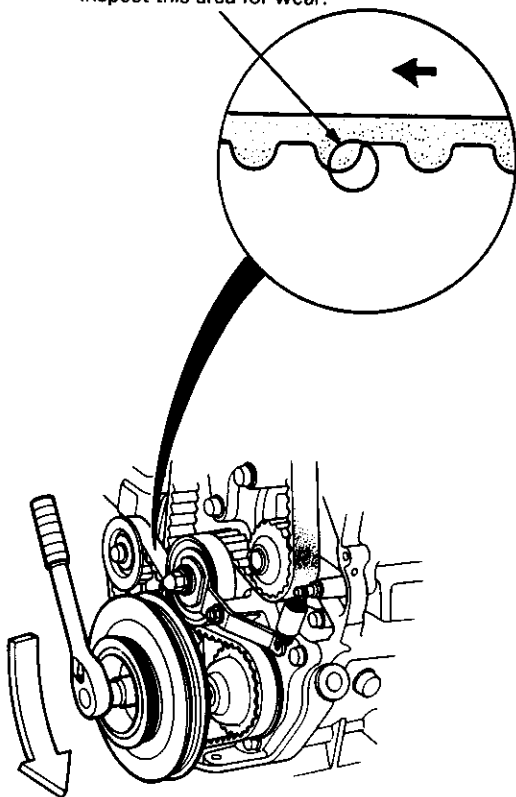

Rotate pulley
and inspect belt.

8. After inspecting, retorque the crankshaft pulley bolt to 220 N-m (22.0 kg-m, 159 lb-ft).

NOTE: Refer to page 6-32 for timing balancer belt tension adjustment.

Timing Belt

Positioning Crankshaft Before Installing Timing Belt

NOTE:

- Install the timing belt with the No. 1 piston at TDC.
- After installing retorque the crankshaft pulley bolt to 220 N·m (22.0 kg·m, 159 lb-ft).

CAMSHAFT TDC POSITION:

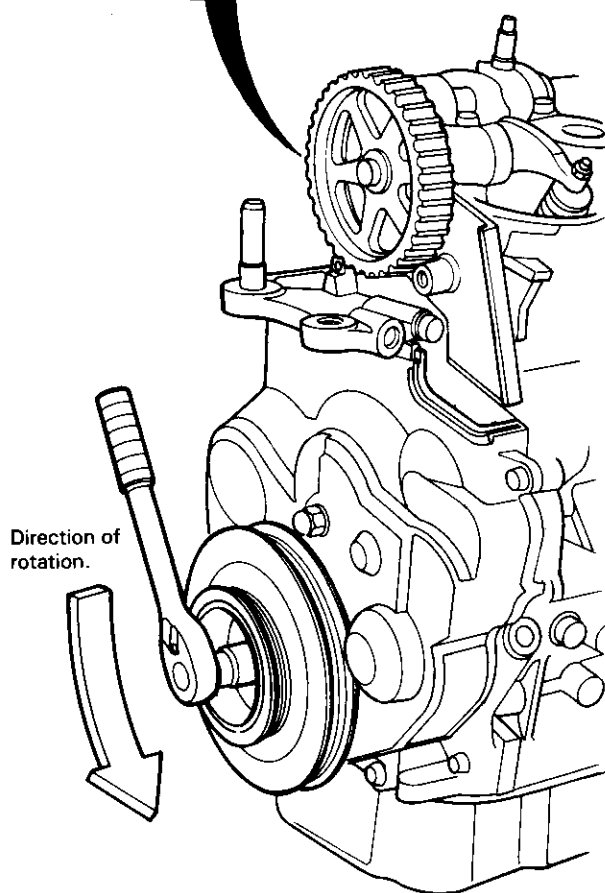
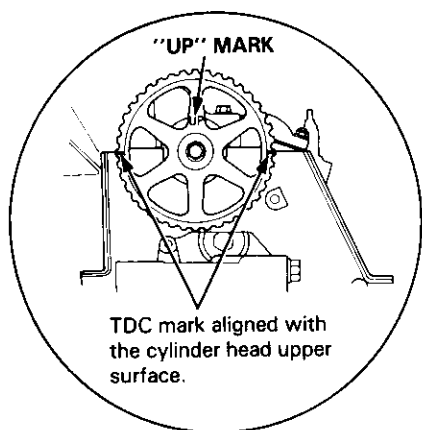

NOTE: When turning the crankshaft with a socket wrench, install the crankshaft pulley and the pulley bolt.

CRANKSHAFT TDC POSITION:

MANUAL TRANSMISSION:

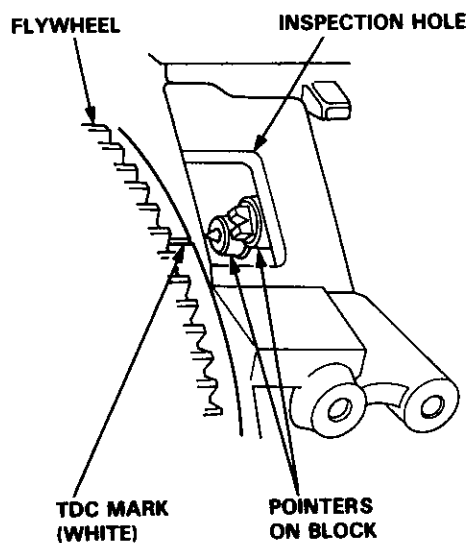

AUTOMATIC TRANSMISSION:

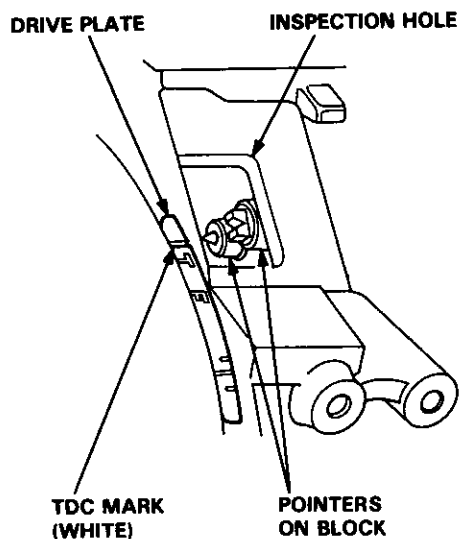

Timing Belt and Timing Balancer Belt



Replacement

CAUTION: Inspect the water pump when replacing the timing belt (Page 10-12).

NOTE: Turn the crankshaft so that the No. 1 piston is at TDC (page 6-28).

1. Remove the splash shield.

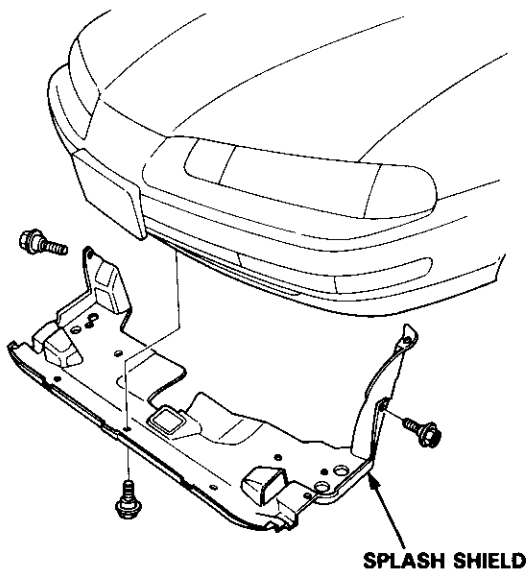

2. Disconnect the connector, then remove the cruise control actuator.

NOTE:

- Do not disconnect the control cable.
- Take care not to bend the cable when removing the actuator. Always replace a kinked cable with a new one.

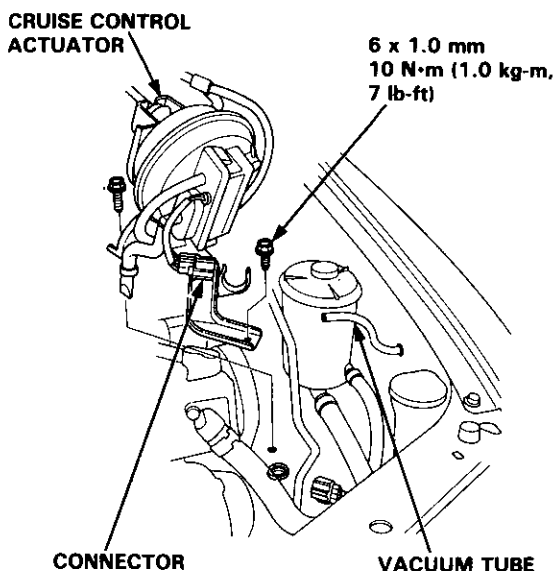

3. Remove the mounting bolts, nuts and P/S pump belt from the power steering (P/S) pump.

NOTE:

- Do not disconnect the P/S pipe and hose.
- After installing, adjust the tension of the P/S pump belt (see section 17).

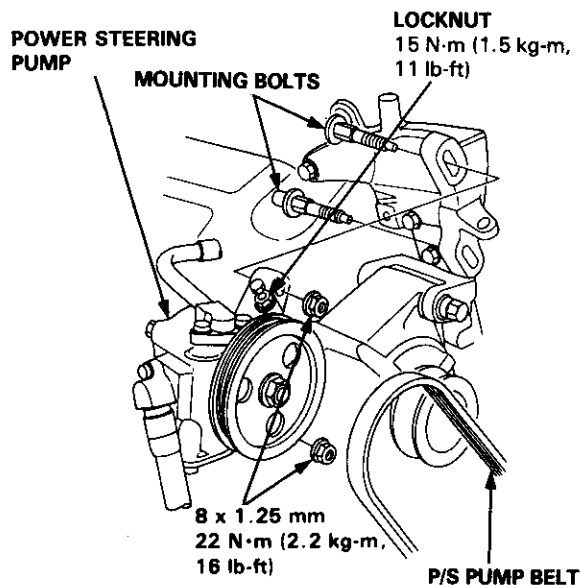

4. Disconnect the alternator terminal and the connector, then remove the engine wire harness from the cylinder head cover.
5. Loosen the alternator mounting bolt/nut and adjusting bolt, then remove the alternator belt.

NOTE: After installing, adjust the tension of the alternator belt (see section 23).

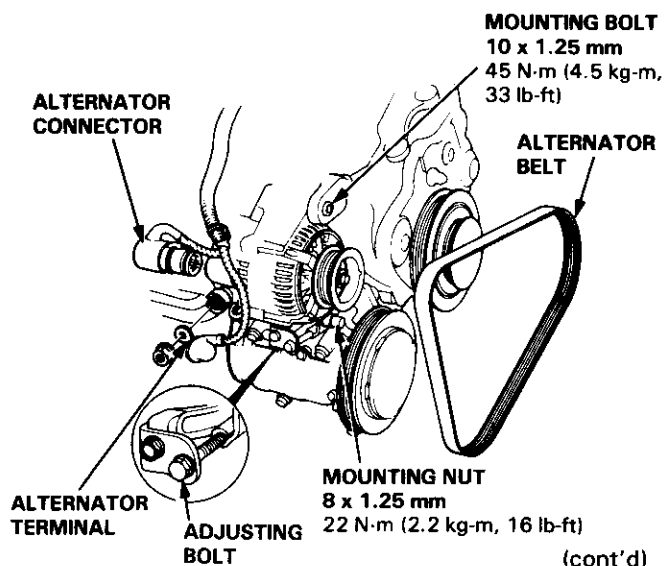

Timing Belt and Timing Balancer Belt

Replacement (cont'd)

6. Remove the cylinder head cover.
7. Remove the side engine mount bracket B (standard for some types).
8. Remove the upper cover.
9. Remove the side engine mount.
10. Remove the dipstick and the pipe.
11. Remove the pulley bolt and the crankshaft pulley. Remove the two rear bolts from the center beam to allow the engine to drop down and give clearance to remove the lower cover.
12. Remove the rubber seal around the adjusting nut. Do not loosen the adjusting nut.
13. Remove the lower cover.

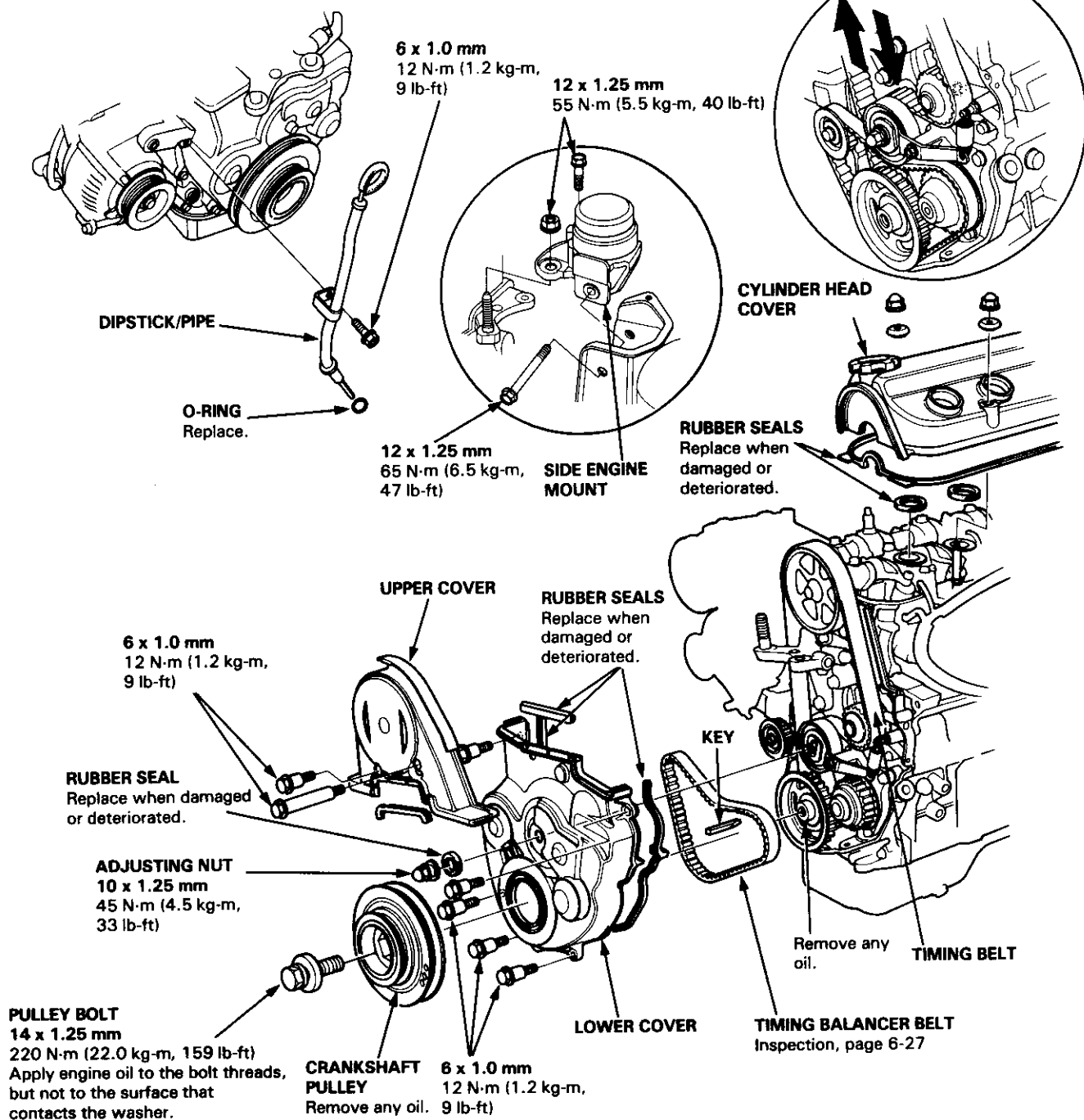



14. Lock the timing belt adjuster arm in place by installing one of the 6 x 1.0 mm lower cover mounting bolts.
15. Loosen the timing belt adjusting nut. Push on the pulley to remove tension from the timing balancer belt, then tighten the adjusting nut.
16. Remove the timing balancer belt.

NOTE: If you are removing only the timing balancer belt, go to step 22. If you are removing both belts, continue with this procedure.

17. Loosen the 6 x 1.0 mm lock bolt and the adjusting nut. Push on the timing belt adjuster pulley to remove tension from the belt, then tighten the adjusting nut.
18. Remove the timing belt.
19. Install the timing belt in the reverse order of removal. Adjust the valve clearances (page 6-34)
 - Before installing the timing belt, the crankshaft and camshaft pulleys as shown on page 6-28.
20. Perform the timing belt tension adjustment (page 6-26).
21. Tighten the 6 x 1.0 mm bolt to lock the timing belt adjuster arm.

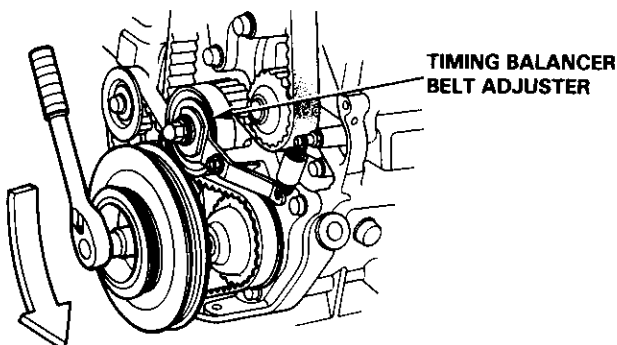
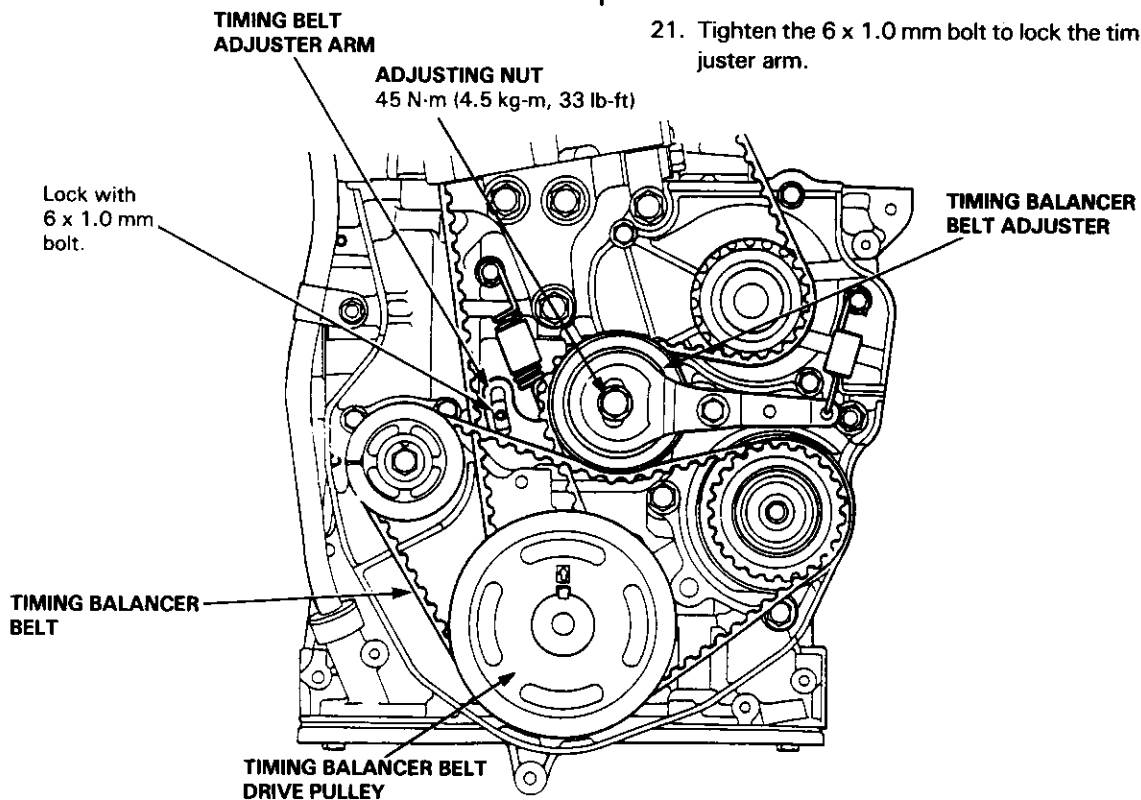

(cont'd)

Timing Belt and Timing Balancer Belt

Replacement (cont'd)

22. Make sure the crankshaft is positioned with the No. 1 piston at TDC.
23. Align the groove on the front balancer after pulley with the pointer on the oil pump housing as shown.
24. Align the rear balancer shaft pulley by using 6 x 100 mm bolt or equivalent as an alignment tool. Scribe a line 74 mm (2.9 in) from the end of the bolt. Insert the bolt into the maintenance hole to the scribed line.
25. Loosen the adjusting nut and verify that the timing balancer belt adjuster moves freely.
26. Install the timing balancer belt. Remove the 6 x 100 mm bolt from the rear balancer shaft.

27. Turn the crankshaft pulley about one turn counter-clockwise, then tighten the adjusting nut to the specified torque.

NOTE: Both belt adjusters are spring-loaded to properly tension the belts. Do not apply any extra pressure to the pulleys or tensioners while performing the adjustment.

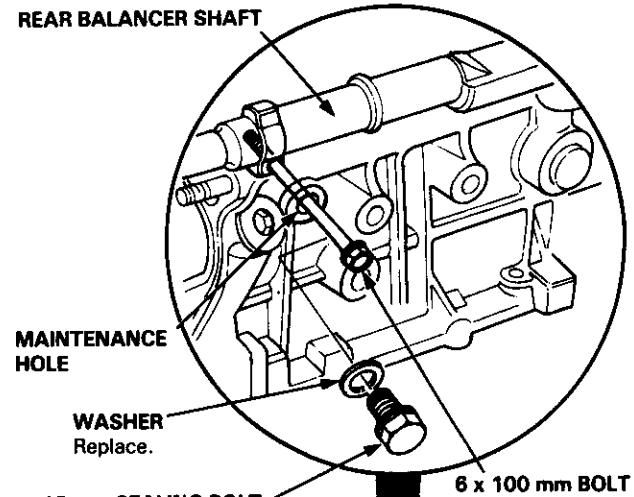
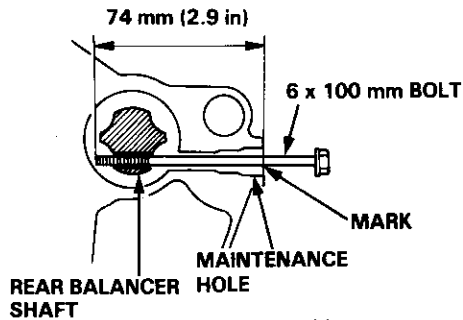

12 mm SEALING BOLT
30 N·m (3.0 kg·m, 22 lb·ft)
NOTE: Tighten the bolt after installing the belt.

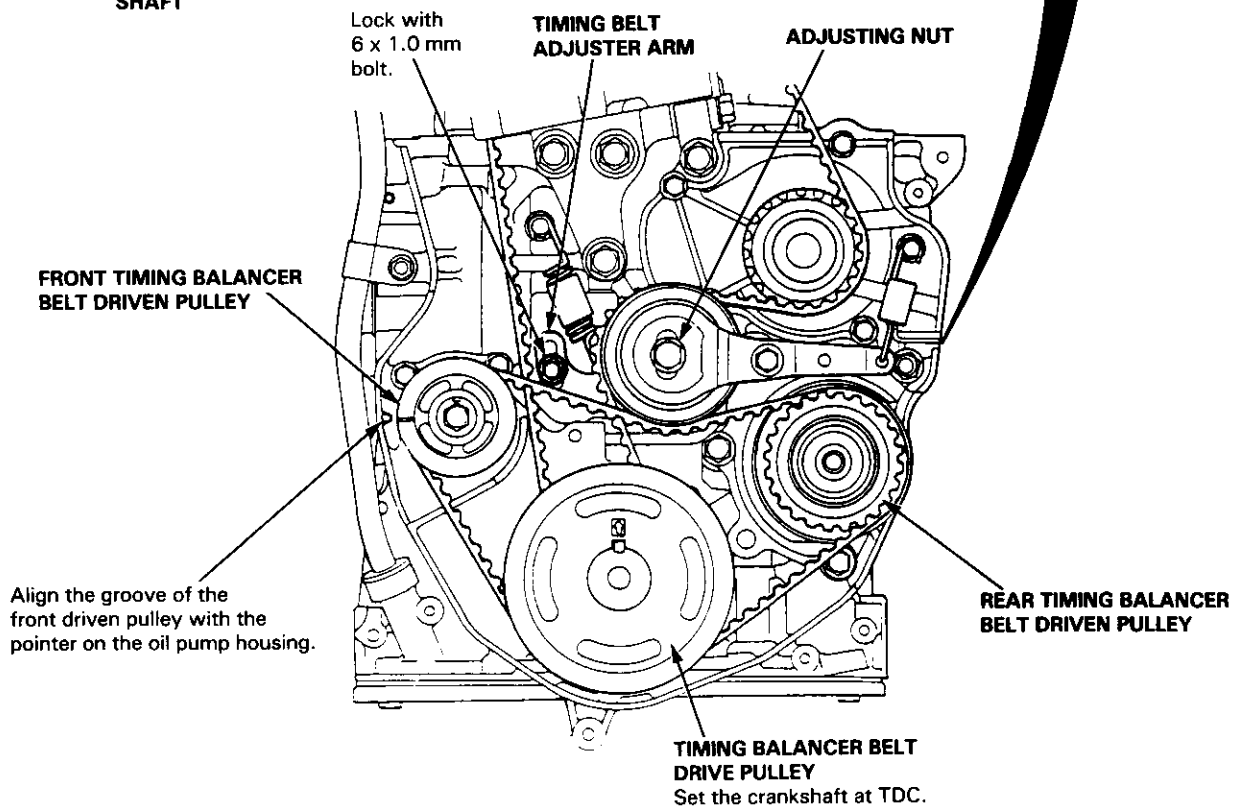



- 28. Remove the 6 x 1.0 mm bolt from the timing belt adjuster arm.
- 29. Remove the crankshaft pulley.
- 30. Install the lower cover.
- 31. Install a rubber seal around the adjusting nut. Do not loosen the nut.

- 32. Install the upper cover.
- 33. Install the crankshaft pulley.
- 34. Coat the threads and seating face of the pulley bolt with engine oil. Install and tighten to the specified torque.

Specified torque: 220 N·m (22.0 kg·m, 159 lb-ft)

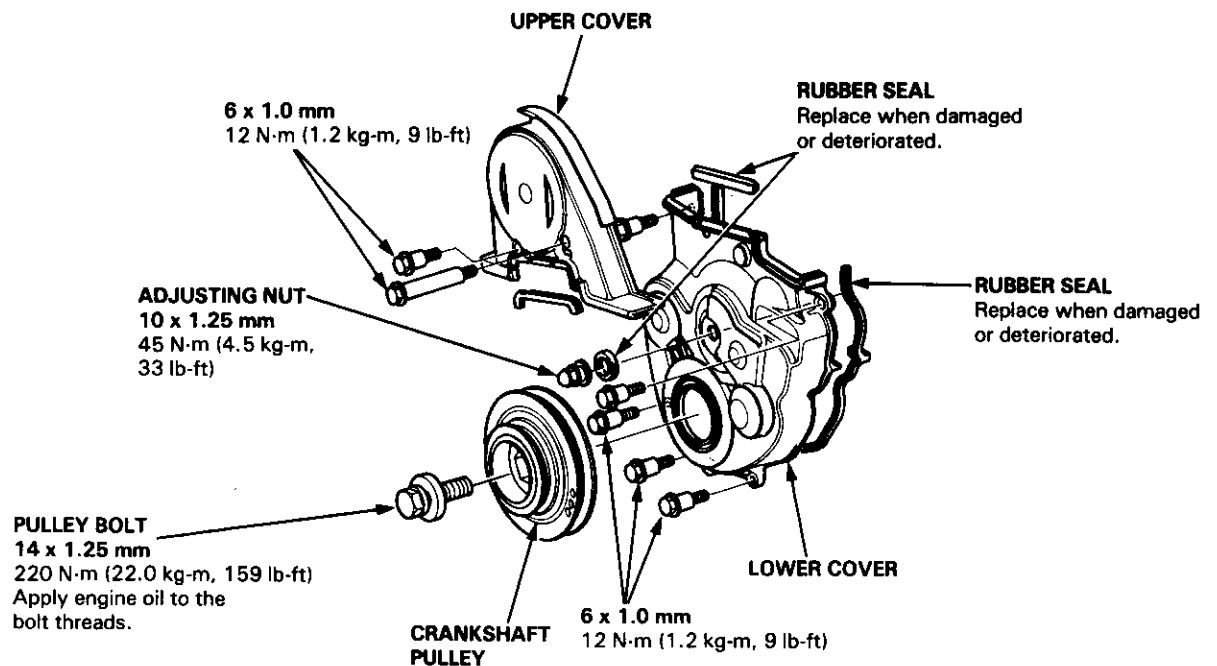

Valve Clearance

Adjustment

NOTE:

- Valves should be adjusted cold when the cylinder head temperature is less than 100°F (38°C).
- After adjusting, retorque the crankshaft pulley bolt to 220 N·m (22.0 kg·m, 159 lb·ft).

1. Remove the cylinder head cover.

INTAKE

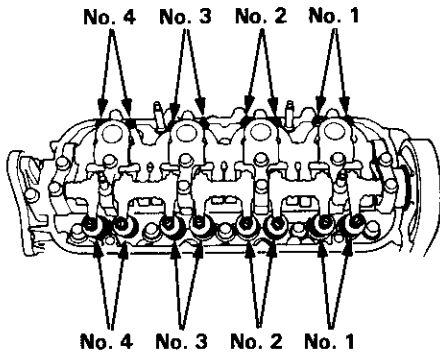

EXHAUST

2. Set No. 1 piston at TDC. "UP" mark on the camshaft pulley should be at top, and TDC grooves on the camshaft pulley should align with cylinder head surface.

Number 1 piston at TDC:

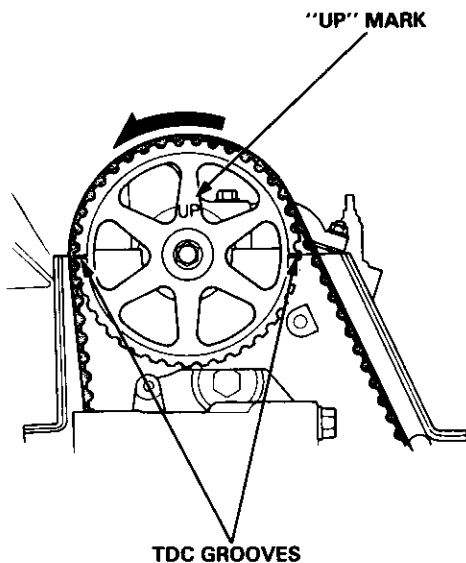

3. Adjust valves on No. 1 cylinder.

Intake: 0.26 mm (0.010 in) $\begin{matrix} +0.02 \text{ mm (0.0008 in)} \\ -0.03 \text{ mm (0.0012 in)} \end{matrix}$

Exhaust: 0.30 mm (0.012 in) $\begin{matrix} +0.02 \text{ mm (0.0008 in)} \\ -0.03 \text{ mm (0.0012 in)} \end{matrix}$

4. Loosen locknut and turn adjustment screw until feeler gauge slides back and forth with slight amount of drag.

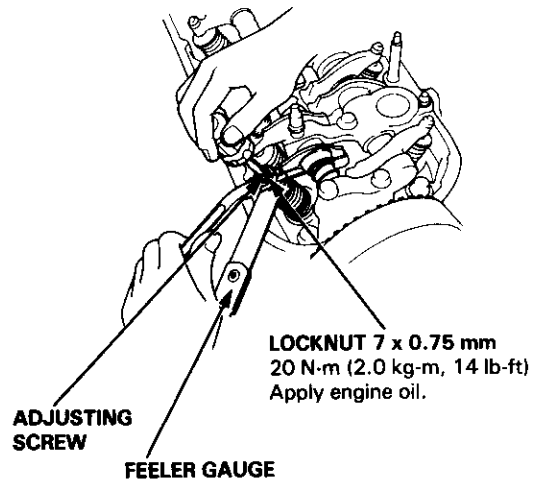

5. Tighten locknut and check clearance again. Repeat adjustment if necessary.

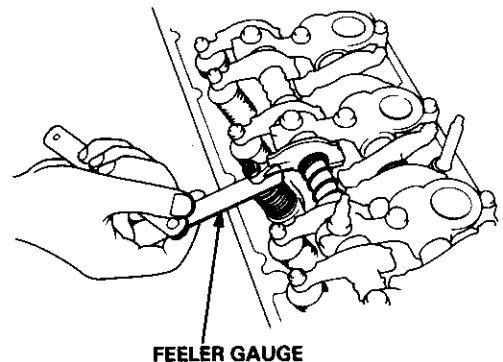



6. Rotate crankshaft 180° counterclockwise (Camshaft pulley turns 90°). The "UP" mark should be at exhaust side. Adjust valves on No. 3 cylinder.

Number 3 Piston at TDC:

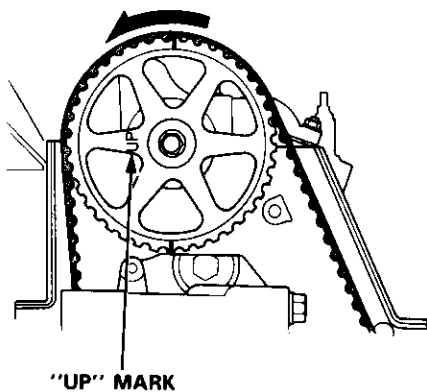

8. Rotate crankshaft 180° counterclockwise to bring No. 2 piston to TDC. The "UP" mark should be at intake side. Adjust valves on No. 2 cylinder.

Number 2 Piston at TDC:

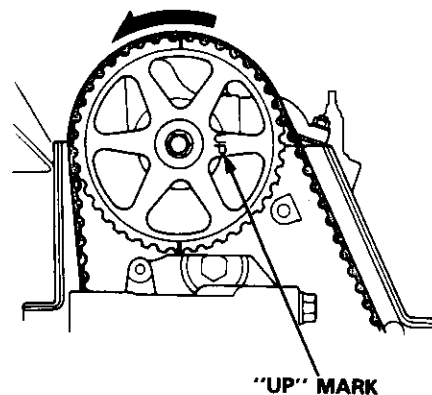

7. Rotate crankshaft 180° counterclockwise to bring No.4 piston to TDC. Both TDC grooves are once again visible. Adjust valves on No. 4 cylinder.

Number 4 Piston at TDC:

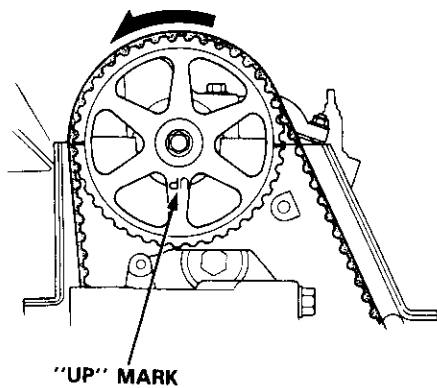

Cylinder Head/Valve Train (H23A1 engine)

Special Tools	6-38	Valve Guides	
Illustrated Index	6-39	Valve Movement	6-52
Valve Seals		Replacement	6-53
Replacement (Cylinder head removal not required)	6-41	Reaming	6-54
Cylinder Head		Rocker Arms/Camshafts and Camshaft Seals/Pulleys	
Removal	6-43	Installation	6-57
Warpage	6-52	Timing Belt and Timing Balancer Belt	
Installation	6-56	Illustrated Index	6-59
Camshaft Pulleys		Replacement	6-63
Removal	6-48	Timing Belt	
Camshafts		Inspection	6-60
Inspection	6-48	Tension Adjustment	6-60
Valves, Valve Springs and Valve Seals		Positioning Crankshaft Before Installing Timing Belt	6-62
Removal	6-50	Timing Balancer Belt	
Valve Spring and Valve Seal Installation Sequence	6-55	Inspection	6-61
Valve Installation	6-55	Valve Clearance	
Valve Seats		Adjustment	6-68
Reconditioning	6-51		



Special Tools

Ref. No.	Tool Number	Description	Qty	Page Reference
①	07GAD-PH70100	Valve Guide Seal Installer	1	6-55
②	07757-PJ1010A	Valve Spring Compressor Attachment	1	6-50
③	07942-6570100	Valve Guide Driver, 6.6 mm	1	6-53, 54
④	07984-657010C or 07984-657010D	Valve Guide Reamer, 6.6 mm	1	6-54



①

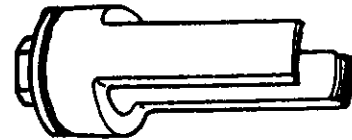

②



③



④

Illustrated Index



CAUTION: To avoid damaging the cylinder head, wait until the engine coolant temperature drops below 100°F (38°C) before removing it.

NOTE: Use new O-rings and gaskets when reassembling.

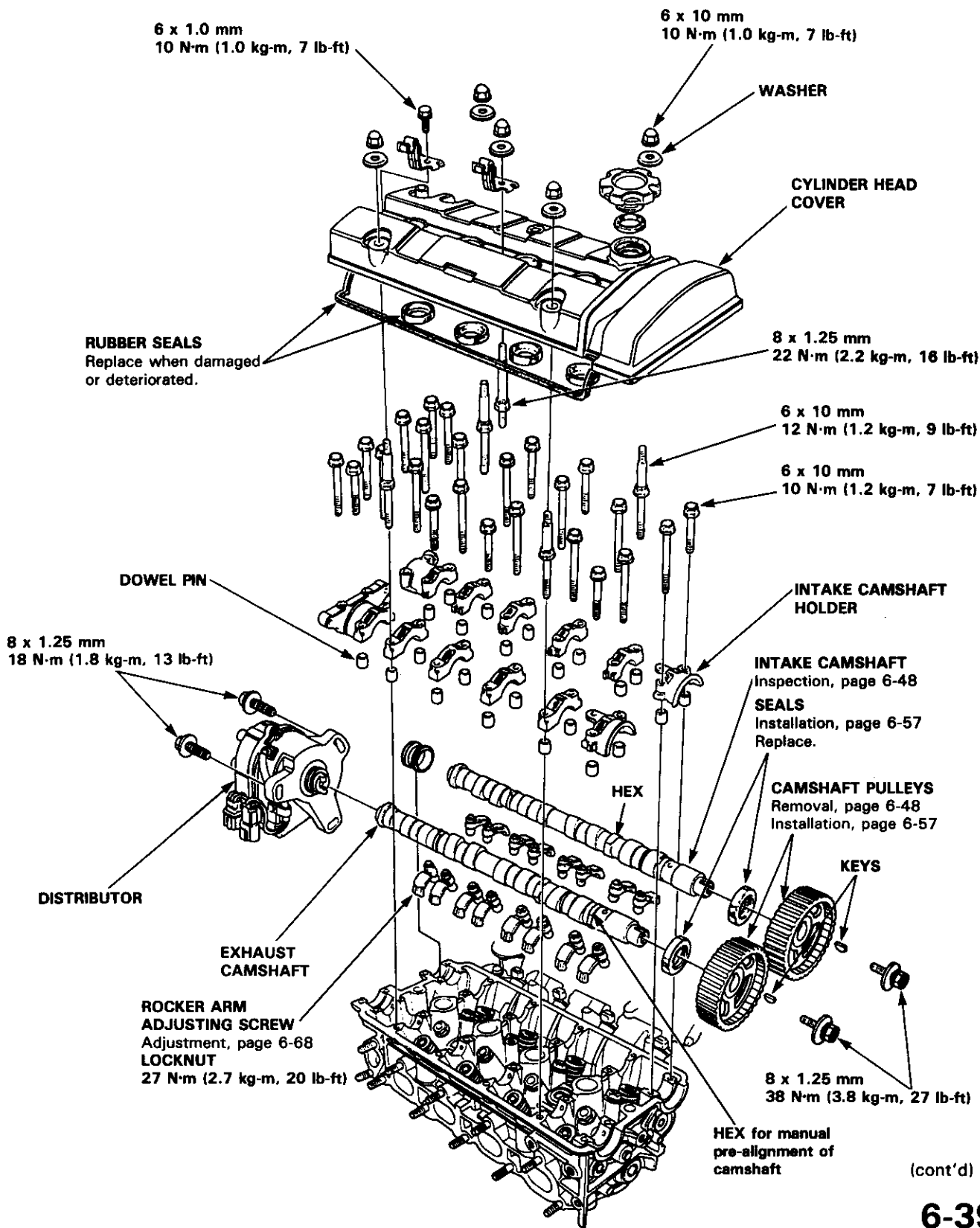

(cont'd)

Illustrated Index

(cont'd)

CAUTION: In handling a metal gasket, take care not to fold it or damage the contact surface of the gasket.

NOTE: Clean the oil control orifice before installing.



Prior to reassembling, clean all the parts in solvent, dry them and apply lubricant to any contact parts.

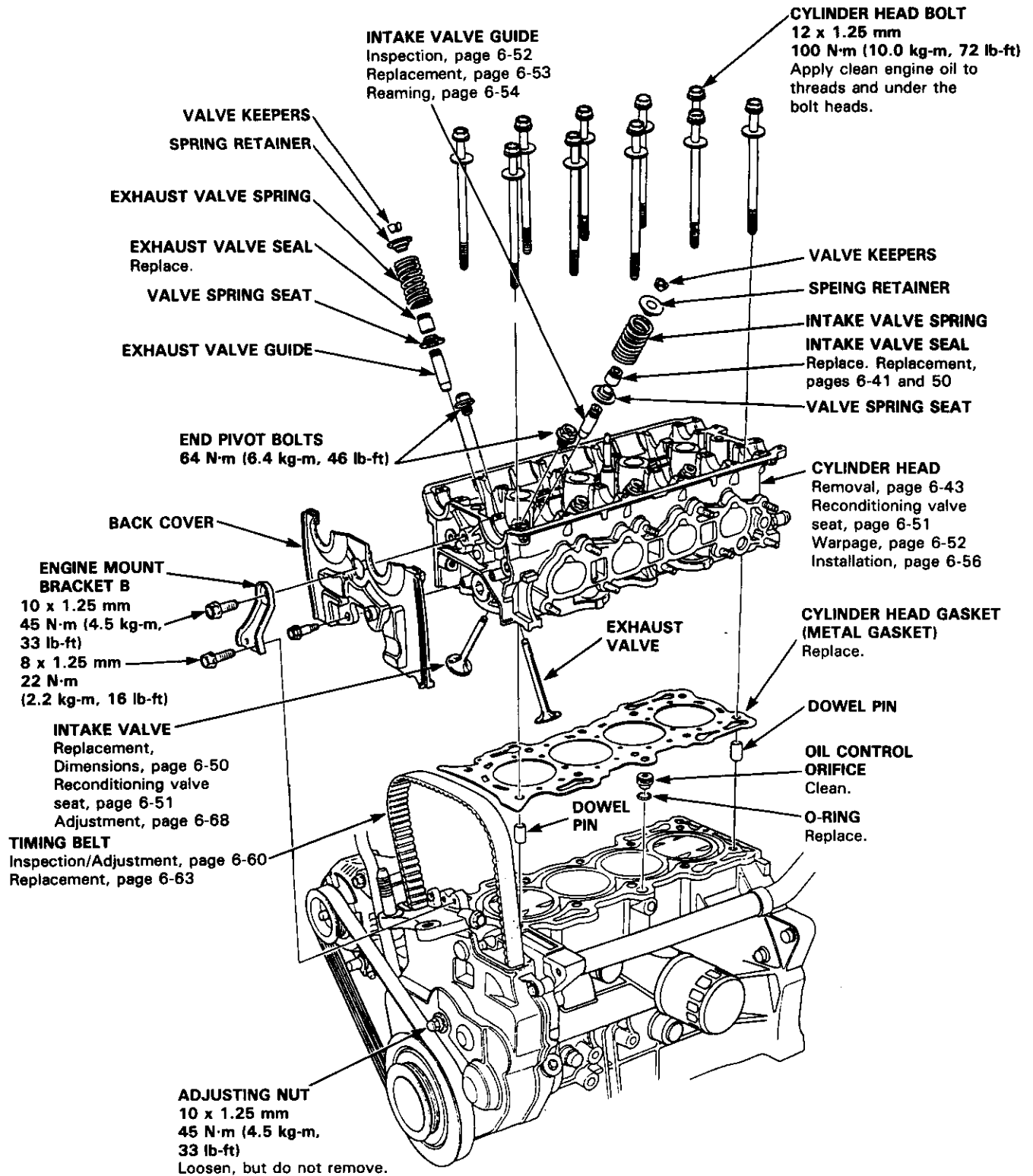

Valve Seals



Replacement (Cylinder head removal not required)

NOTE: Cylinder head removal is not required in this procedure.

Use the procedure shown below applies when using the in-car valve spring compressor (Snap-on YA8845).

⚠ WARNING Always wear approved eye protection when using the in-car valve spring compressor.

1. Turn the crankshaft so that the No. 1 and the No. 4 pistons are at TDC.
2. Remove the cylinder head cover.
3. Loosen and remove timing belt from the camshaft pulleys.
4. Remove the distributor.
5. Remove the camshaft holder bolts, then remove the camshaft holders, the camshafts, and the rocker arms.
6. Using the 6 mm bolts supplied with the tool, mount the two uprights to the cylinder as shown.
7. Insert the cross shaft through the bottom holes of the two uprights.

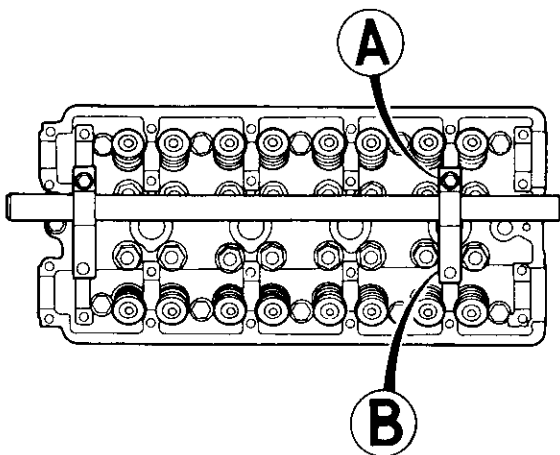

Intake Valve Seals:

8. Select the 1-1/8 in. diameter long compressor attachment and fasten the attachment to the hole of the lever arm with the speed pin supplied.
9. Insert an air adaptor into the spark plug hole. Pump air into the cylinder to keep the valve closed while compressing springs and removing the valve keepers.
10. Position the lever arm under the cross shaft so the lever is perpendicular to the shaft and the compressor attachment rests on top of the retainer for the spring being compressed. Use the front position slot on the lever as shown.

NOTE: Put shop towels over the oil passages to prevent the valve keepers from falling into the cylinder head.

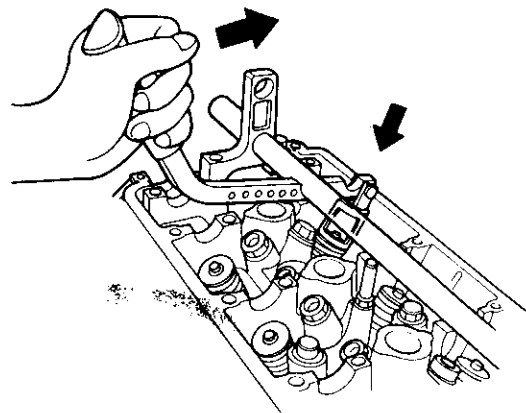
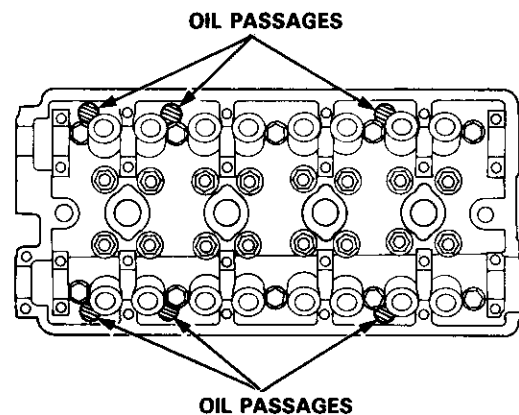

(cont'd)

Valve Seals

Replacement (Cylinder head removal not required) (cont'd)

11. Using a downward motion on the lever arm, compress the valve spring and remove the keepers from the valve stem. Slowly release pressure on the spring.
12. Repeat step 11 for the other intake valve in that cylinder.
13. Remove the valve seals (page 6-50).
14. Replace the valve seals (page 6-55).
15. Install the springs, the retainers and the keepers in reverse order of removal.

Exhaust Valve Seals:

16. Select the 7/8 in. diameter compressor attachment and fasten the attachment to the No. 5 hole of the lever arm with the speed pin.
17. Position the lever arm under the cross shaft so it is perpendicular to the shaft and the compressor attachment rests on top of the retainer for the spring being compressed. Use the front position slot on the lever as shown.

NOTE: Put shop towels over the oil passages to prevent the valve keepers from falling into the cylinder head.

18. Using a downward motion on the lever arm, compress the valve spring and remove the keepers from the valve stem. Slowly release pressure on the spring.
19. Repeat step 18 for the other exhaust valve in that cylinder.
20. Remove the valve seals (page 6-50).
21. Replace the valve seals (page 6-55).
22. Install the springs, the retainers and the keepers in reverse order of removal.
23. Repeat steps 8 to 22 for the other cylinders.

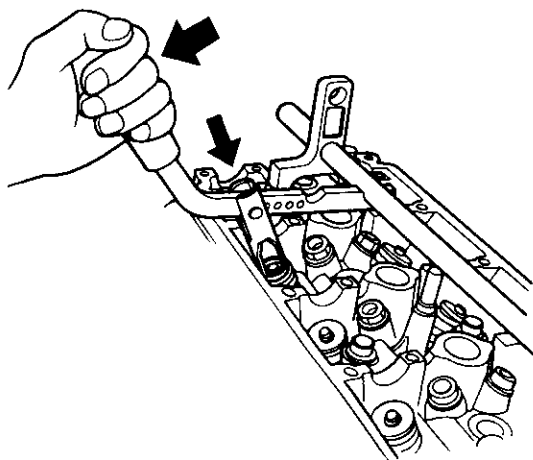

Cylinder Head

Removal

Engine removal is not required for this procedure.

⚠ WARNING

- Make sure jacks and safety stands are placed properly and hoist brackets are attached to correct positions on the engine.
- Make sure the car will not roll off stands and fall while you are working under it.

CAUTION:

- Use fender covers to avoid damaging painted surfaces.
- Unspecified items are common.
- Unplug the wiring connectors carefully while holding the connector portion to avoid damage.
- Mark all wiring and hoses to avoid misconnection. Also, be sure that they do not contact other wiring or hoses or interfere with other parts.
- To avoid damaging the cylinder head, wait until the engine coolant temperature drops below 100°F (38°C) before loosening the retaining bolts.

NOTE:

- Inspect the timing belt before removing the cylinder head.
- Turn the crankshaft pulley so that the No. 1 piston is at top dead center (page 6-62).
- Mark all emission hoses before disconnecting them.
- The radio may have a coded theft protection circuit. Be sure to get the customer's code number before.
 - Disconnecting the battery.
 - Removing the No. 43 (10A) fuse. (In the under-hood fuse/relay box)
 - Removing the radio.

After service, reconnect power to the radio and turn it on. When the word "CODE" is displayed, enter the customer's 5-digit code to restore radio operation.

1. Disconnect the negative terminal from the battery.
2. Drain the engine coolant (see section 10).
 - Remove the radiator cap to speed draining.
3. Relieve the fuel pressure.

⚠ WARNING

Do not smoke while working on fuel system, keep open flame or spark away from work area. Drain fuel only into an approved container.

4. Remove the intake air duct.
5. Remove the fuel feed hose and evaporative emission (EVAP) control canister hose from the intake manifold.

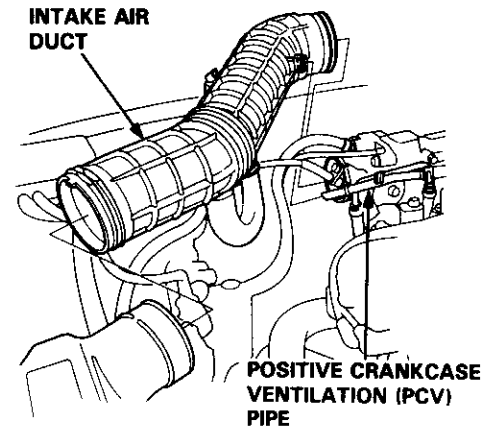

6. Remove the throttle control cable from the throttle body (A/T only).

NOTE:

- Take care not to bend the cable when removing it. Always replace any kinked cable with a new one.
- Adjust the throttle cable when installing (see section 11).

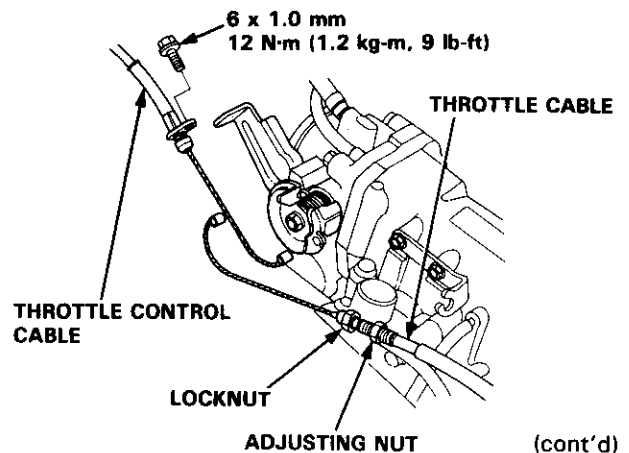

Cylinder Head

Removal (cont'd)

7. Remove the fuel feed hose, the fuel return hose and the brake booster vacuum hose.

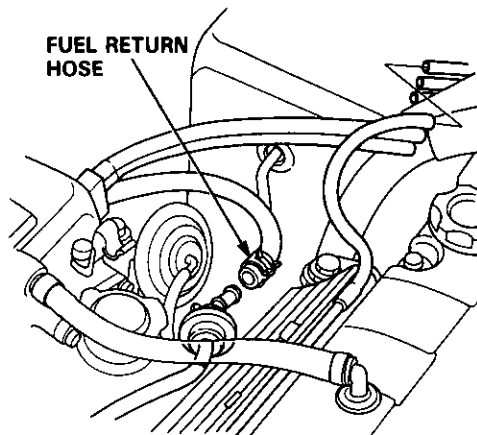
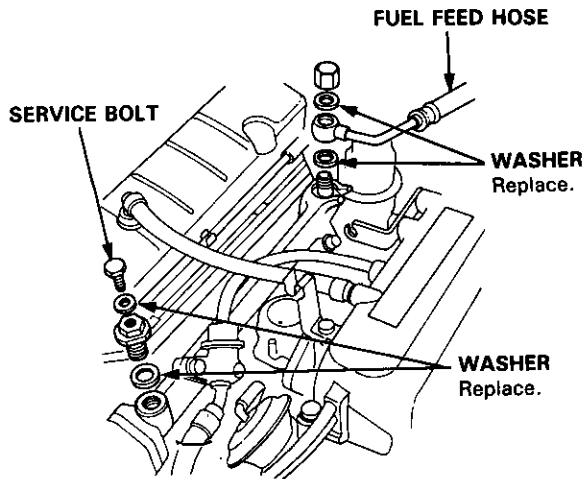

8. Remove the following engine wire harness connectors and clamps from the cylinder head and the intake manifold:

- Four fuel injector connectors
- Intake air temperature (IAT) sensor connector
- Idle air control (IAC) valve connector
- Throttle position (TP) sensor connector
- Exhaust gas recirculation (EGR) valve lift sensor connector
- Ground cable terminals
- Engine coolant temperature (ECT) switch B connector
- Heated oxygen sensor (HO2S) connector
- ECT sensor connector
- ECT gauge sending unit connector
- Ignition control module (ICM) connector
- CKP/TDC/CYP sensor connector
- Vehicle speed sensor (VSS) connector
- Ignition coil connector
- Intake air bypass solenoid valve connector
- ECT switch A connector
- Knock sensor connector

9. Remove the engine ground cable from the cylinder head cover.

10. Disconnect the alternator terminal and connector, then remove the engine wire harness from the cylinder head cover.

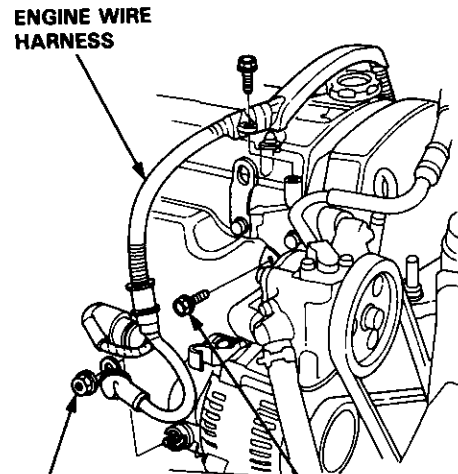

6 x 1.0 mm
8 N·m (0.8 kg-m, 6 lb-ft)

6 x 1.0 mm
10 N·m (1.0 kg-m, 7 lb-ft)

11. Remove the power steering (P/S) pump belt and pump.

- Do not disconnect the P/S hoses.

8 x 1.25 mm
22 N·m (2.2 kg-m,
16 lb-ft)

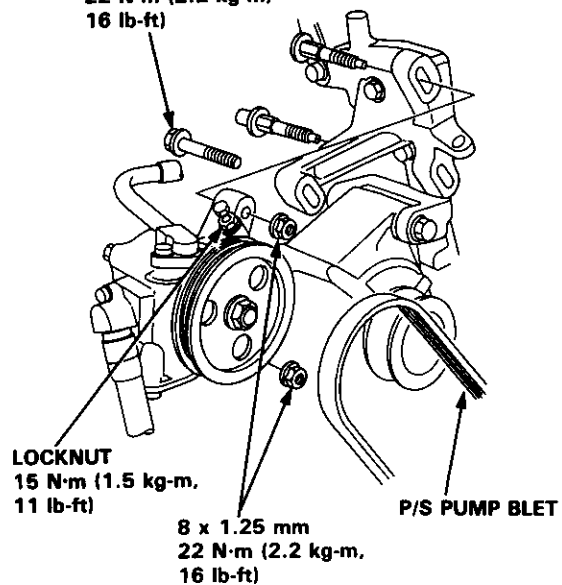



12. Remove the ignition coil.

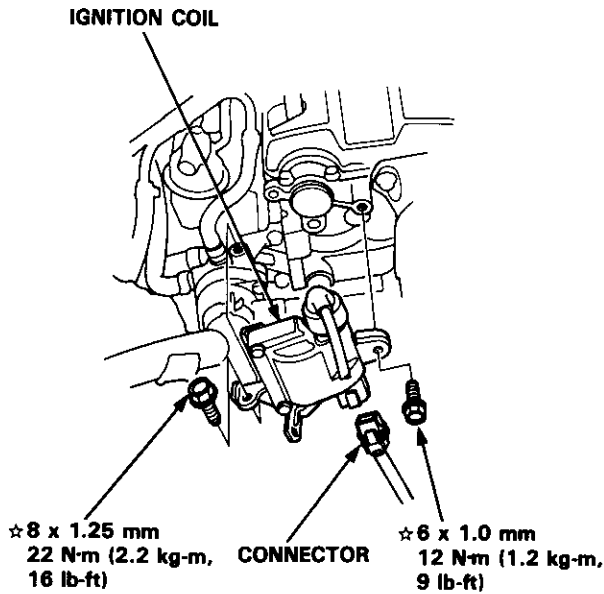

13. Remove the emission vacuum hoses and water bypass hoses from the intake manifold assembly.

14. Remove the radiator upper hose and heater hose from the cylinder head.

15. Remove the water bypass hose and the thermostat housing.

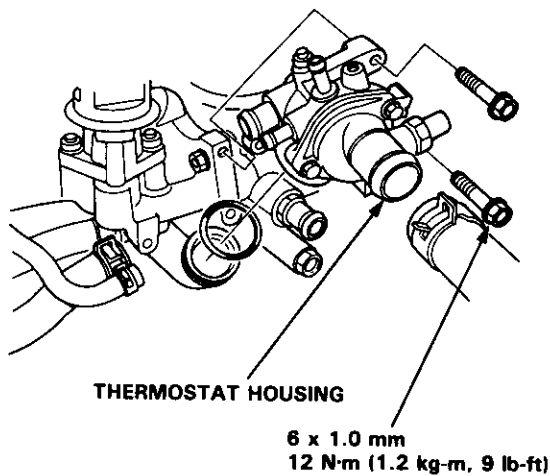

☆: CORROSION RESISTANT BOLT

16. Remove the intake manifold bracket and intake manifold.

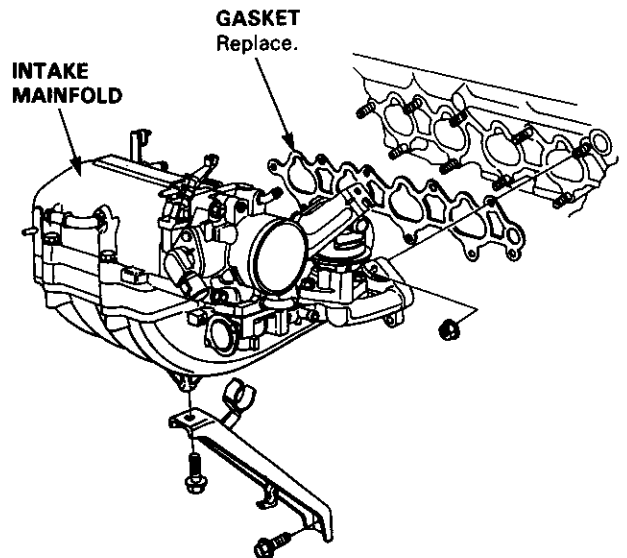

17. Remove the self-locking nuts and disconnect the exhaust manifold and exhaust pipe A.

18. Remove the heat insulator (cars equipped with A/C), exhaust manifold bracket and exhaust manifold.

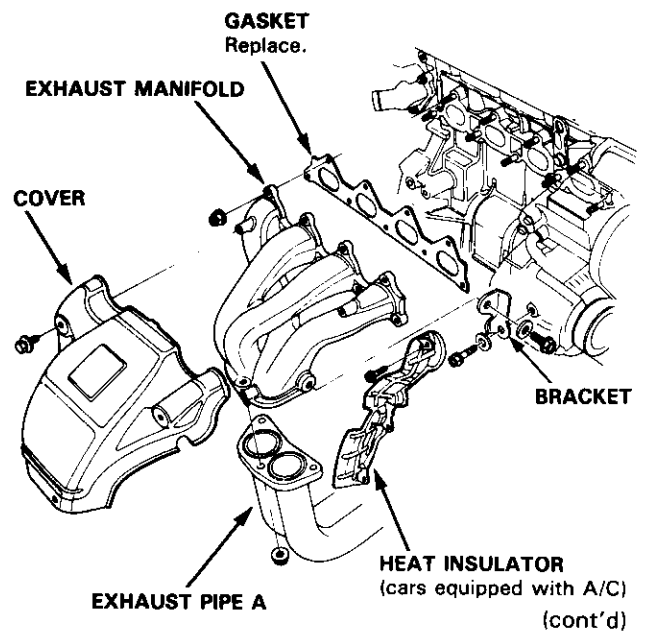

Cylinder Head

Removal (cont'd)

19. Remove the PCV hose, then remove the cylinder head cover.
20. Remove the middle cover.
21. Loosen the adjusting nut 180°.
22. Push the tensioner to release tension from the timing belt, then retighten the adjusting nut.

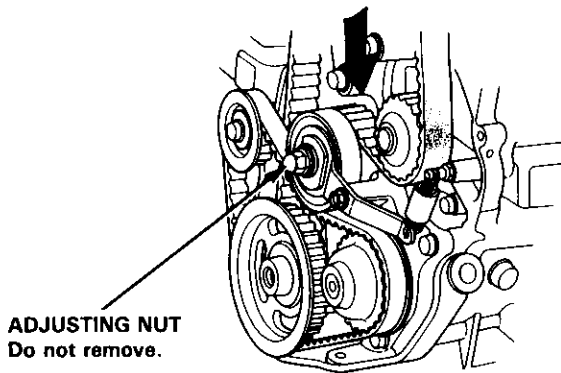

23. Remove the timing belt from the camshaft pulleys.

CAUTION: Do not crimp or bend the timing belt more than 90° or less than 25 mm (1 in) in diameter.

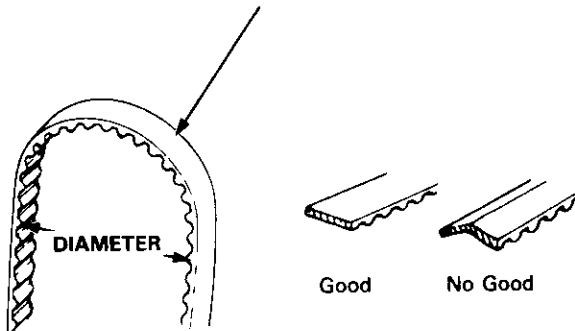

24. Remove the camshaft pulleys.

NOTE: To set the camshafts at TDC for No. 1 cylinder, align the holes in the camshafts with the holes in the No. 1 camshaft holders and insert 5.0 mm pin punches.

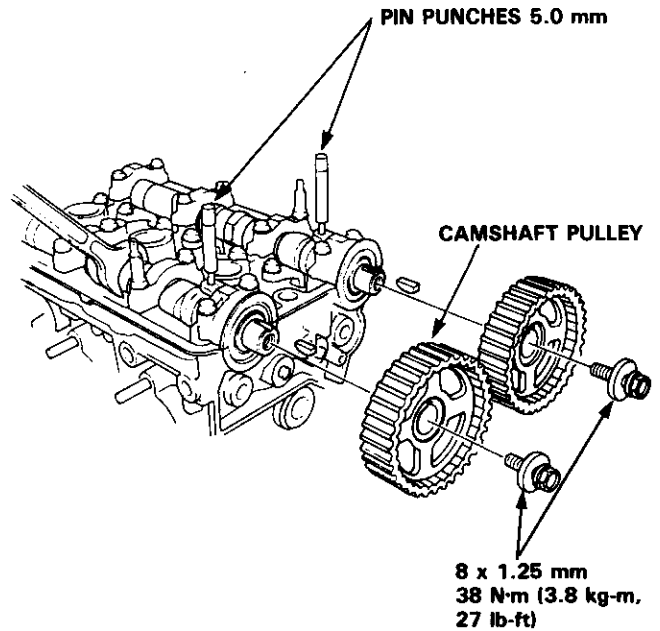

25. Loosen the rocker arm adjusting screws, then remove the camshaft holders and camshafts.

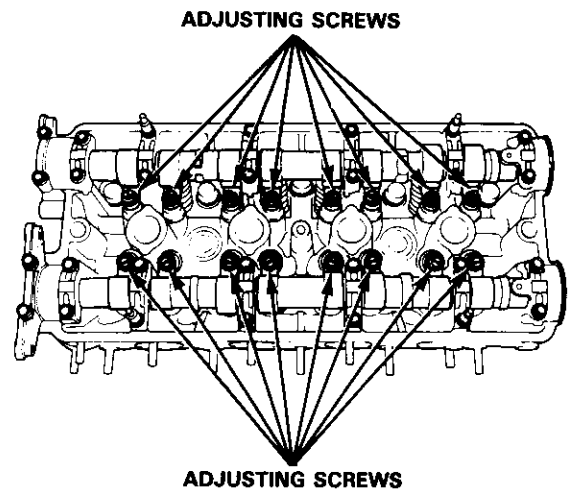



26. Remove the side engine mount bracket B and back cover.

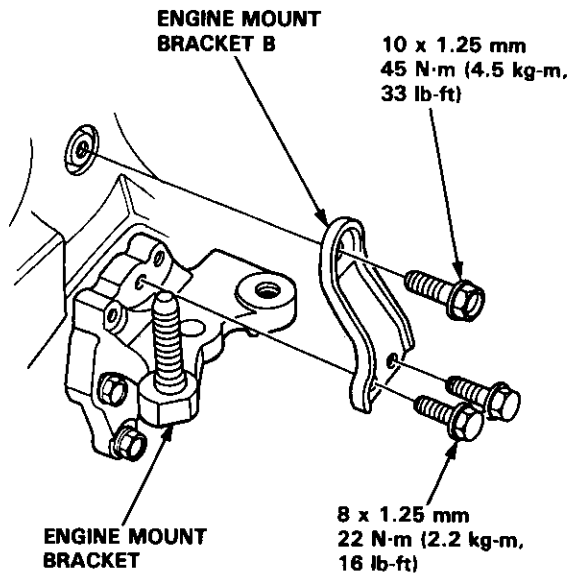

27. Remove the cylinder head bolts, then remove the cylinder head.

CAUTION: To prevent warpage, unscrew the bolts in sequence 1/3 turn at a time; repeat until all bolts are loosened.

CYLINDER HEAD BOLT LOOSENING SEQUENCE

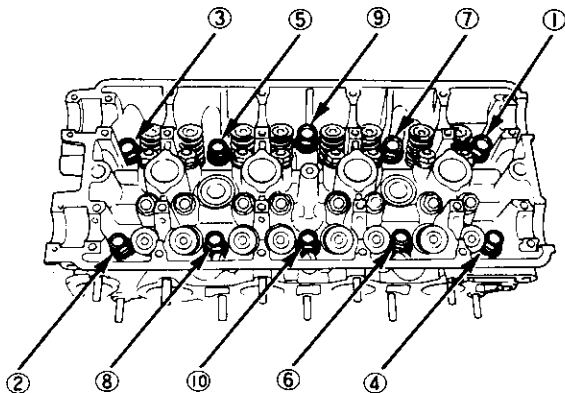

NOTE: Separate the cylinder head from the block with a flat tip screwdriver as shown.

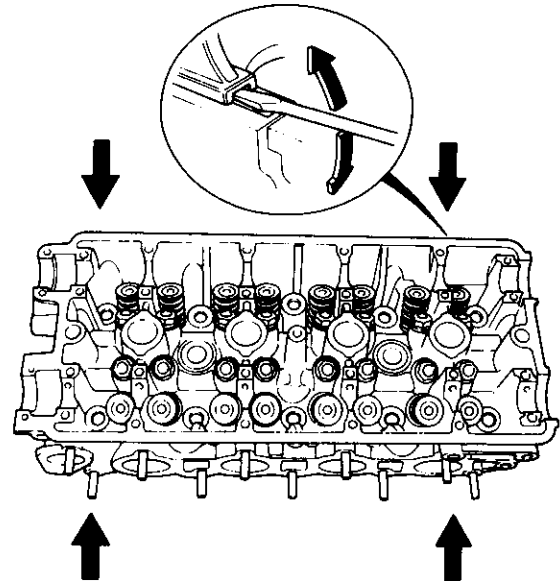

Camshaft Pulleys

Removal

1. To ease reassembly, turn the pulley until the "UP" marks face up, and the front timing marks are aligned with the marks on the pulleys.

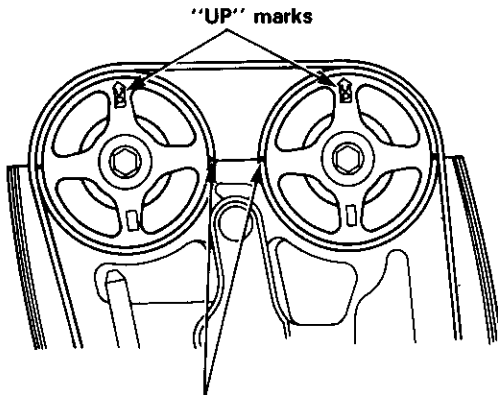

Align the marks on the pulleys.

2. Remove the timing belt.
3. Remove the pulley bolts, then remove the camshaft pulleys.

NOTE: To set the camshafts at TDC for No. 1 cylinder, align the holes in the camshafts with the holes in the No. 1 camshaft holders and insert 5.0 mm pin punches.

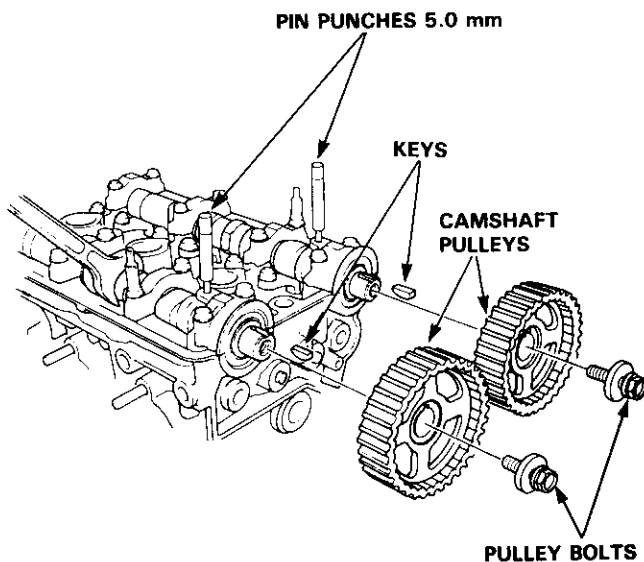

Camshafts

Inspection

NOTE: Do not rotate camshaft during inspection.

1. Remove the rocker arms.

NOTE: Rocker arms must be installed in the same position if reused.

2. Put the camshafts and the camshaft holders on the cylinder head, then tighten the bolts to the specified torque.

Specified torque:

Except Intake ⑤, ⑦. Exhaust ⑥, ⑧:

10 N·m (1.0 kg-m, 7 lb-ft)

Intake ⑤, ⑦. Exhaust ⑥, ⑧:

12 N·m (1.2 kg-m, 9 lb-ft)

TIGHTENING SEQUENCE

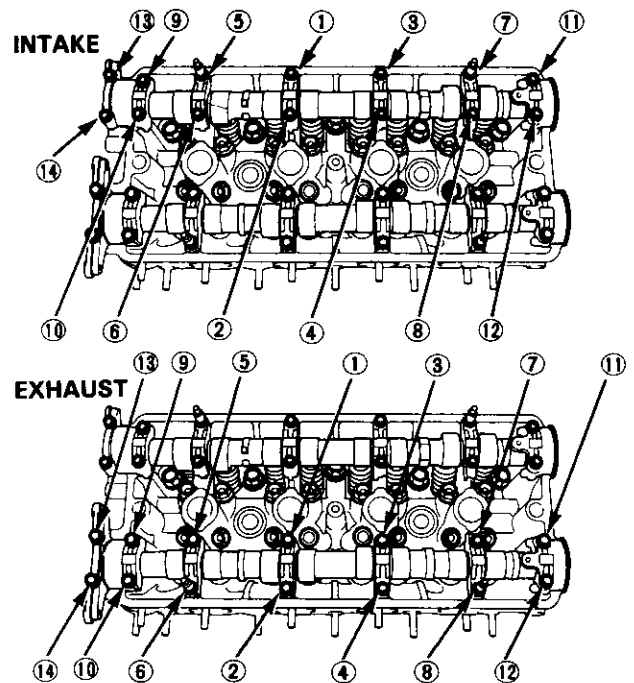



3. Seat camshafts by pushing them toward distributor end of cylinder head.
4. Zero dial indicator against end of camshaft, then push camshaft back and forth, and read the end play.

Camshaft End Play:

Standard (New): 0.05–0.15 mm
(0.002–0.006 in)

Service Limit: 0.5 mm (0.02 in)

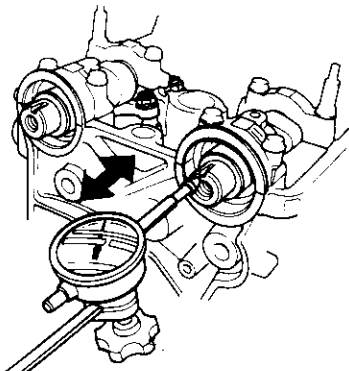

5. Remove the camshaft holder bolts from the cylinder head.

- Lift camshaft out of cylinder head, wipe clean, then inspect lift ramps. Replace camshaft if lobes are pitted, scored, or excessively worn.
- Clean the camshaft bearing surfaces in the cylinder head, then set camshaft back in place.
- Insert plastigage strip across each journal.
- Install the camshaft holders and torque bolts to the values and in the sequence shown on page 6-48.

6. Measure widest portion of plastigage on each journal.

Camshaft-to-Holder Oil Clearance:

Standard (New): 0.050–0.089 mm
(0.0020–0.0035 in)

Service Limit: 0.15 mm (0.006 in)

Exhaust No. 5 Journal:

Standard (New): 0.100–0.139 mm
(0.0039–0.0055 in)

Service Limit: 0.20 mm (0.008 in)

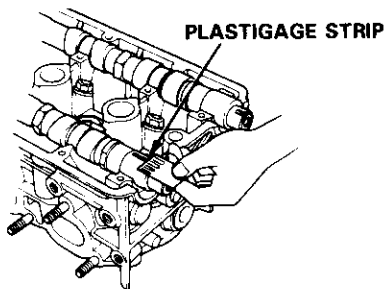

7. If camshaft-to-holder oil clearance is out of tolerance:

- And the camshaft has already been replaced, you must replace the cylinder head.
- If camshaft has not been replaced, first check total runout with the camshaft supported on V-blocks.

Camshaft Total Runout:

Standard (New): 0.03 mm (0.001 in) max.

Service Limit: 0.06 mm (0.002 in)

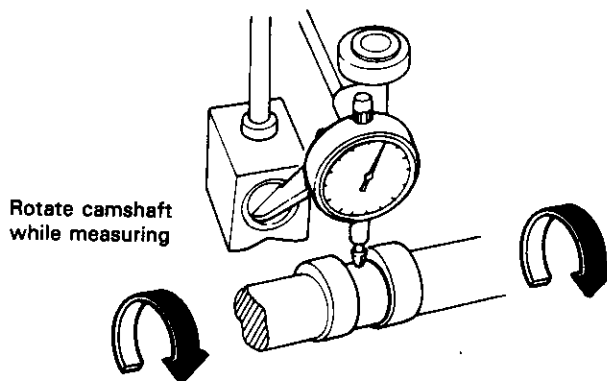

- If the total runout of the camshaft is within tolerance, replace the cylinder head.
- If the total runout is out of tolerance, replace the camshaft and recheck. If the oil clearance is still out of tolerance, replace the cylinder head.

8. Measure camshaft lobe height.

Intake Standard: 33.661 mm (1.3252 in)

Exhaust Standard: 33.725 mm (1.3278 in)

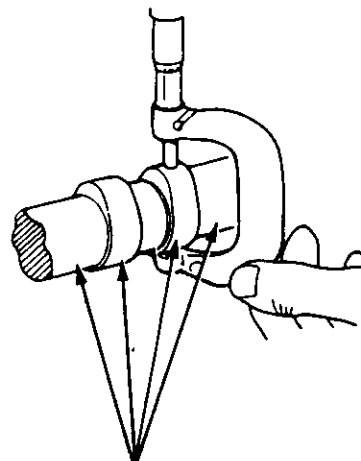

Valves, Valve Springs and Valve Seals

Removal

NOTE: Identify valves and valve springs as they are removed so that each item can be reinstalled in its original position.

1. Tap each valve stem with a plastic mallet to loosen valve keepers before installing the spring compressor.
2. Install the spring compressor. Compress spring and remove valve keeper.

**VALVE SPRING COMPRESSOR
COMMERCIALY AVAILABLE**

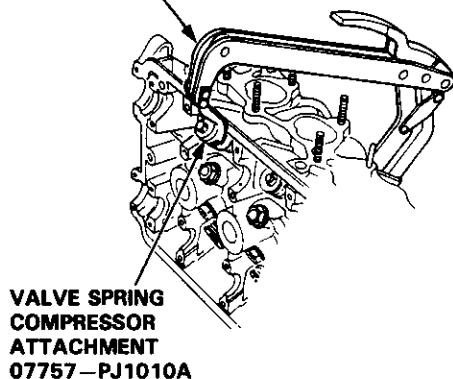

3. Install the special tools as shown.

**VALVE GUIDE SEAL REMOVER
LISLE P/N 57900 or KD3350
COMMERCIALY AVAILABLE**

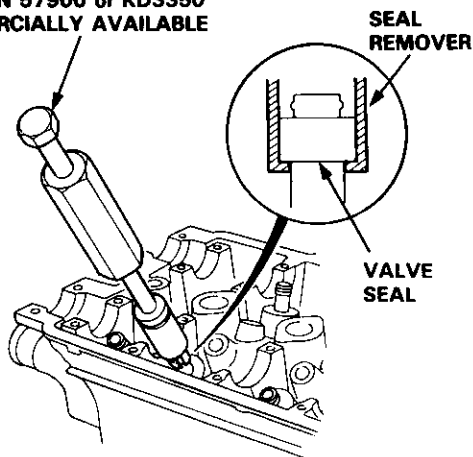

4. Remove the valve seal.

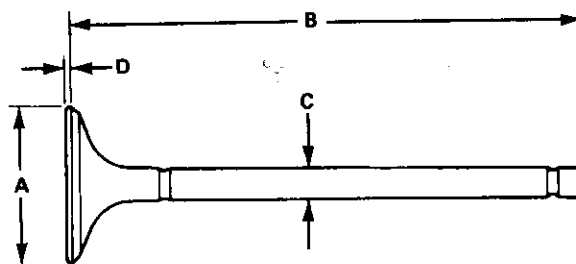
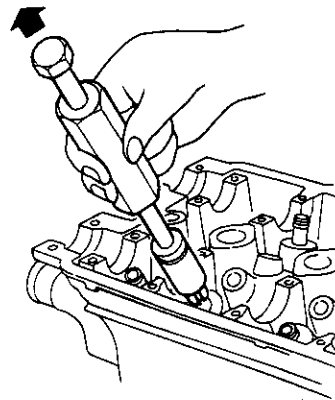

Intake Valve Dimensions

- A Standard (New):** 33.90–34.10 mm
(1.335–1.343 in)
- B Standard (New):** 102.50–102.80 mm
(4.035–4.047 in)
- C Standard (New):** 6.580–6.590 mm
(0.2591–0.2594 in)
- C Service Limit:** 6.55 mm (0.258 in)
- D Standard (New):** 0.85–1.15 mm
(0.033–0.045 in)
- D Service Limit:** 0.65 mm (0.026 in)

Exhaust Valve Dimensions

- A Standard (New):** 28.90–29.10 mm
(1.138–1.161 in)
- B Standard (New):** 101.40–101.70 mm
(3.992–4.004 in)
- C Standard (New):** 6.550–6.560 mm
(0.2579–0.2583 in)
- C Service Limit:** 6.52 mm (0.257 in)
- D Standard (New):** 1.05–1.35 mm
(0.041–0.053 in)
- D Service Limit:** 0.85 mm (0.033 in)



Valve Seats

Reconditioning

1. Renew the valve seats in the cylinder head using a valve seat cutter.

NOTE: If guides are worn (page 6-52), replace them (page 6-53) before cutting the valve seats.

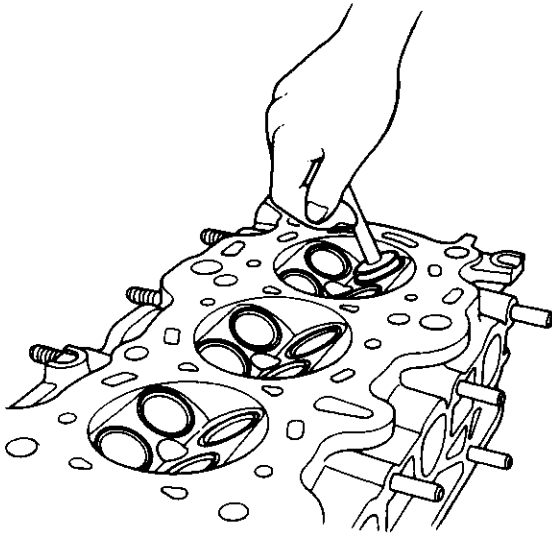

2. Carefully cut a 45° seat, removing only enough material to ensure a smooth and concentric seat.
3. Bevel the upper edge of the seat with the 30° cutter and the lower edge of the seat with the 60° cutter. Check width of seat and adjust accordingly.
4. Make one more very light pass with the 45° cutter to remove any possible burrs caused by the other cutters.

Valve Seat Width (Intake and exhaust):

Standard: 1.25–1.55 mm
(0.049–0.061 in)
Service Limit: 2.00 mm (0.079 in)

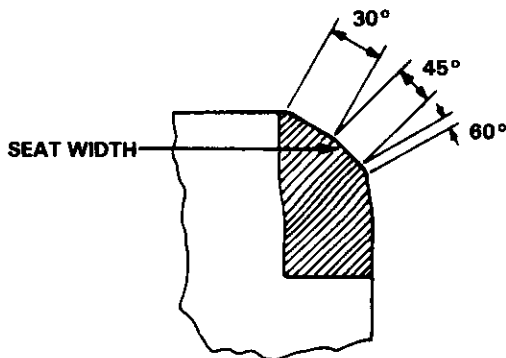

5. After resurfacing the seat, inspect for even valve seating: Apply Prussian Blue compound to the valve face, and insert valve in original location in the head, then lift it and snap it closed against the seat several times.

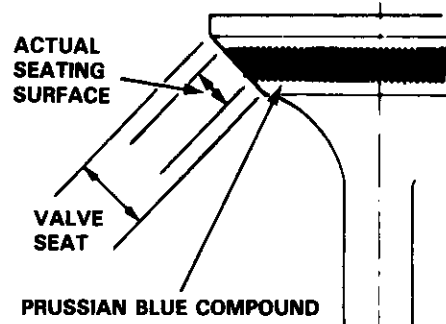

6. The actual valve seating surface, as shown by the blue compound, should be centered on the seat.
 - If it is too high (closer to the valve stem), you must make a second cut with the 60° cutter to move it down, then one more cut with the 45° cutter to restore seat width.
 - If it is too low (close to the valve edge), you must make a second cut with the 30° cutter to move it up, then one more cut with the 45° cutter to restore seat width.

NOTE: The final cut should always be made with the 45° cutter.

7. Insert intake and exhaust valves in the head and measure valve stem installed height.

Intake Valve Stem Installed Height:

Standard (New): 39.365–39.835 mm
(1.5498–1.5683 in)

Service Limit: 40.085 (1.5781 in)

Exhaust Valve Stem Installed Height:

Standard (New): 39.165–39.635 mm
(1.5419–1.5604 in)

Service Limit: 39.885 mm (1.5703 in)

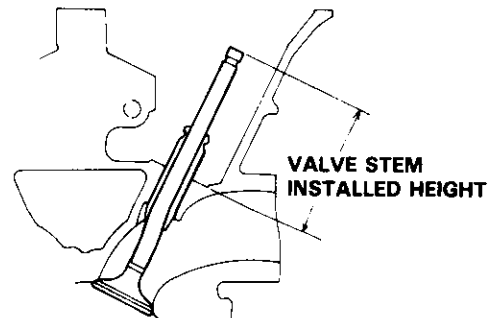

8. If valve stem installed height is over the service limit, replace valve and recheck. If still over the service limit, replace cylinder head; the valve seat in the head is too deep.

Cylinder Head

Warpage

NOTE: If camshaft-to-holder oil clearances (page 6-49) are not within specification, the cylinder head cannot be resurfaced.

If camshaft-to-holder oil clearances are within specifications, check the cylinder head for warpage.

- If warpage is less than 0.05 mm (0.002 in) cylinder head resurfacing is not required.
- If warpage is between 0.05 mm (0.002 in) and 0.2 mm (0.008 in), resurface cylinder head.
- Maximum resurface limit is 0.2 mm (0.008 in) based on a height of 132.0 mm (5.20 in)

PRECISION STRAIGHT EDGE

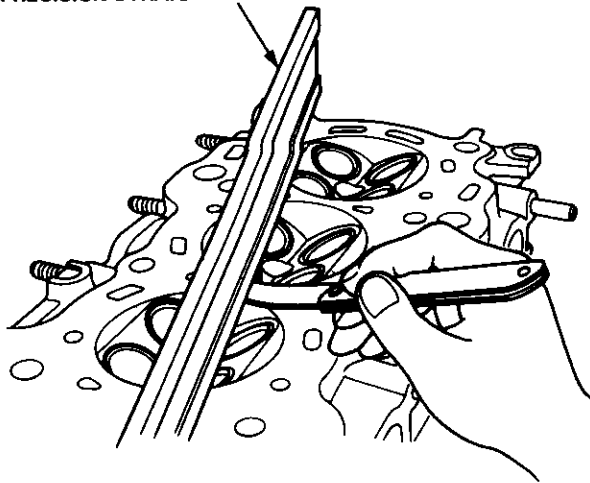

Measure along edges, and 3 ways across center.

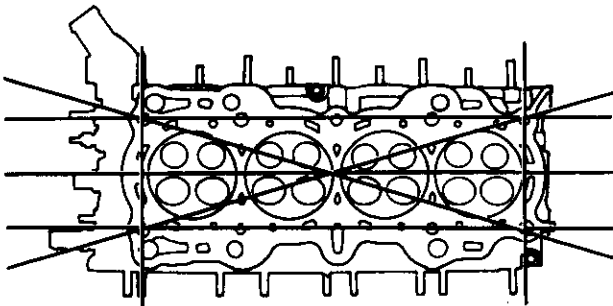

Cylinder Head Height:
Standard (New): 131.95–132.05 mm
(5.195–5.199 in)

Valve Guides

Valve Movement

Measure the guide-to-stem clearance with a dial indicator while rocking the stem in the direction of normal thrust (wobble method).

Intake Valve Stem-to-Guide Clearance:

Standard (New): 0.04–0.10 mm
(0.002–0.004 in)

Service Limit: 0.16 mm (0.006 in)

Exhaust Valve Stem-to-Guide Clearance:

Standard (New): 0.10–0.16 mm
(0.004–0.006 in)

Service Limit: 0.22 mm (0.009 in)

Valve extended 10 mm out from seat.

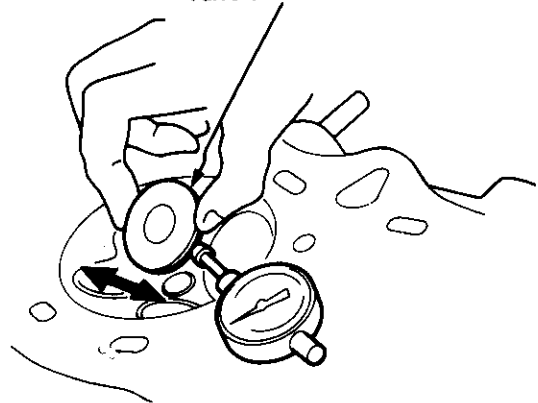

- If measurement exceeds the service limit, recheck using a new valve.
- If measurement is now within the service limit, reassemble using a new valve.
- If measurement still exceeds limit, recheck using alternate method below, then replace valve and guide, if necessary.

NOTE: An alternate method of checking guide to stem clearance is to subtract the O.D. of the valve stem, measured with a micrometer, from the I.D. of the valve guide, measured with an inside micrometer or ball gauge.

Take the measurements in three places along the valve stem and three places inside the valve guide. The difference between the largest guide measurement and the smallest stem measurement should not exceed the service limit.

Intake Valve Stem-to-Guide Clearance:

Standard (New): 0.02–0.05 mm
(0.001–0.002 in)

Service Limit: 0.08 mm (0.003 in)

Exhaust Valve Stem-to-Guide Clearance:

Standard (New): 0.05–0.08 mm
(0.002–0.003 in)

Service Limit: 0.11 mm (0.004 in)



Replacement

1. As illustrated in the removal steps of this procedure, use a commercially—available air-impact driver attachment modified to fit the diameter of the valve guides. In most cases, the same procedure can be done using Valve Guide Drivers and a conventional hammer. Tool numbers are at the end of this procedure.

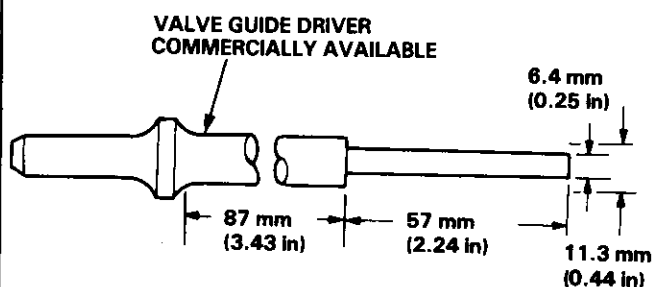

Removal and installation
VALVE GUIDE DRIVER, 6.6 mm
07942-6570100

2. Select the proper replacement guides and chill them in the freezer section of a refrigerator for about an hour.
3. Use a hot plate or oven to evenly heat the cylinder head to 300°F (150°C). Monitor the temperature with a cooking thermometer.

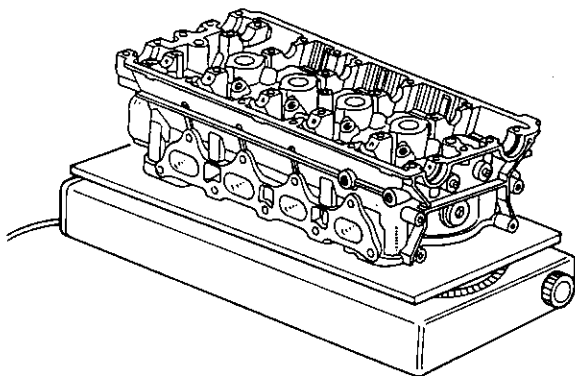

CAUTION:

- Do not use a torch; it may warp the head.
- Do not get the head hotter than 300°F (150°C); excessive heat may loosen the valve seats.
- To avoid burns, use heavy gloves when handling the heated cylinder head.

4. Working from the camshaft side, use the driver and an air hammer to drive the guide about 2 mm (0.1 in) towards the combustion chamber. This will knock off some of the carbon and make removal easier.

CAUTION:

- Always wear safety goggles or a face shield when using the air hammer.
- Hold the air hammer directly in line with the valve guide to prevent damaging the driver.

5. Turn the head over and drive the guide out toward the camshaft side of head.

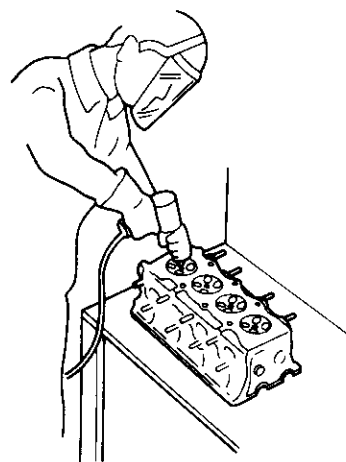

VALVE GUIDE DRIVER
COMMERCIALY AVAILABLE

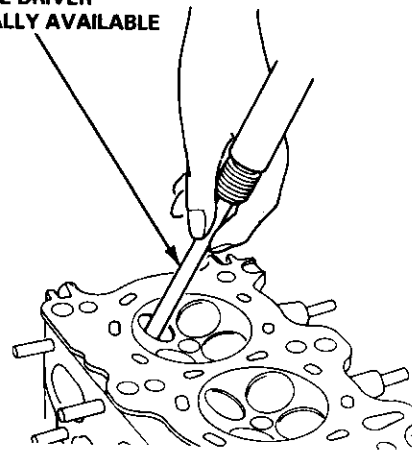

If a valve guide still won't move, drill it out with a 8 mm (5/16 inch) bit, then try again.

CAUTION: Drill guides only in extreme cases; you could damage the cylinder head if the guide breaks.

6. Remove the new guide(s) from the refrigerator, one at a time, as you need them.

(cont'd)

Valve Guides

Replacement (cont'd)

7. Slip a 6.5 mm (0.26 in) steel washer and the correct driver attachment over the end of the driver (The washer will absorb some of the impact and extend the life of the driver).

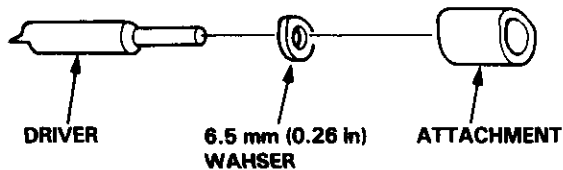

8. Install the new guide(s) from the camshaft side of the head; drive each one in until the attachment bottoms on the head. If you have all sixteen guides to do, you may have to reheat the head one or two more times.

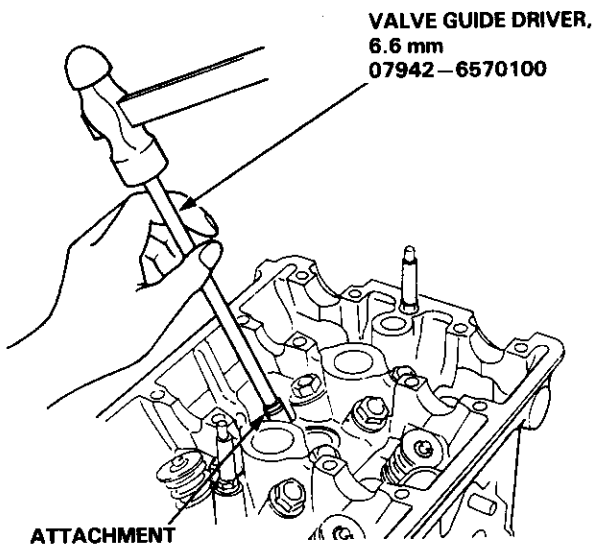

Valve Guide Installed Height:

Standard (New):

Intake: 13.25–13.75 mm
(0.522–0.541 in)

Exhaust: 13.75–14.25 mm
(0.541–0.561 in)

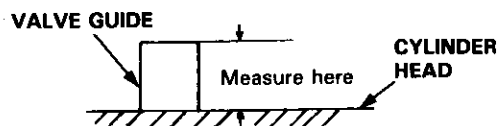

Reaming

NOTE: For new valve guides only.

1. Coat both reamer and valve guide with cutting oil.
2. Rotate the reamer clockwise the full length of the valve guide bore.
3. Continue to rotate the reamer clockwise while removing it from the bore.
4. Thoroughly wash the guide in detergent and water to remove any cutting residue.
5. Check clearance with a valve (page 6-52)
 - Verify that the valve slides in the intake and exhaust valve guides without exerting pressure.

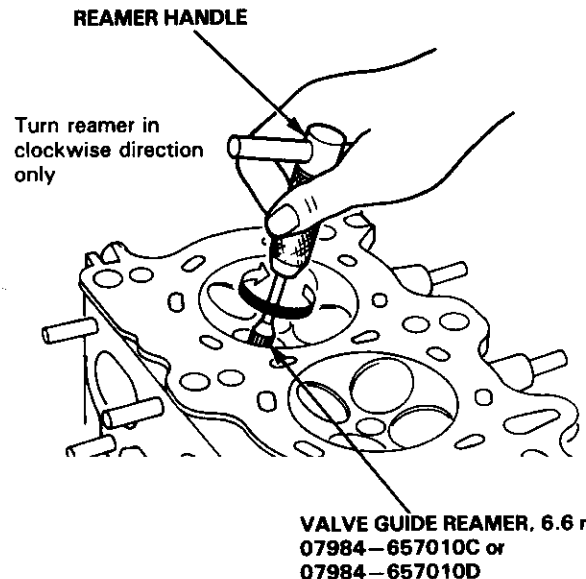



Valves, Valve Springs and Valve Seals

Valve Spring and Valve Seal Installation Sequence

NOTE: Exhaust and intake valve seals are NOT interchangeable.

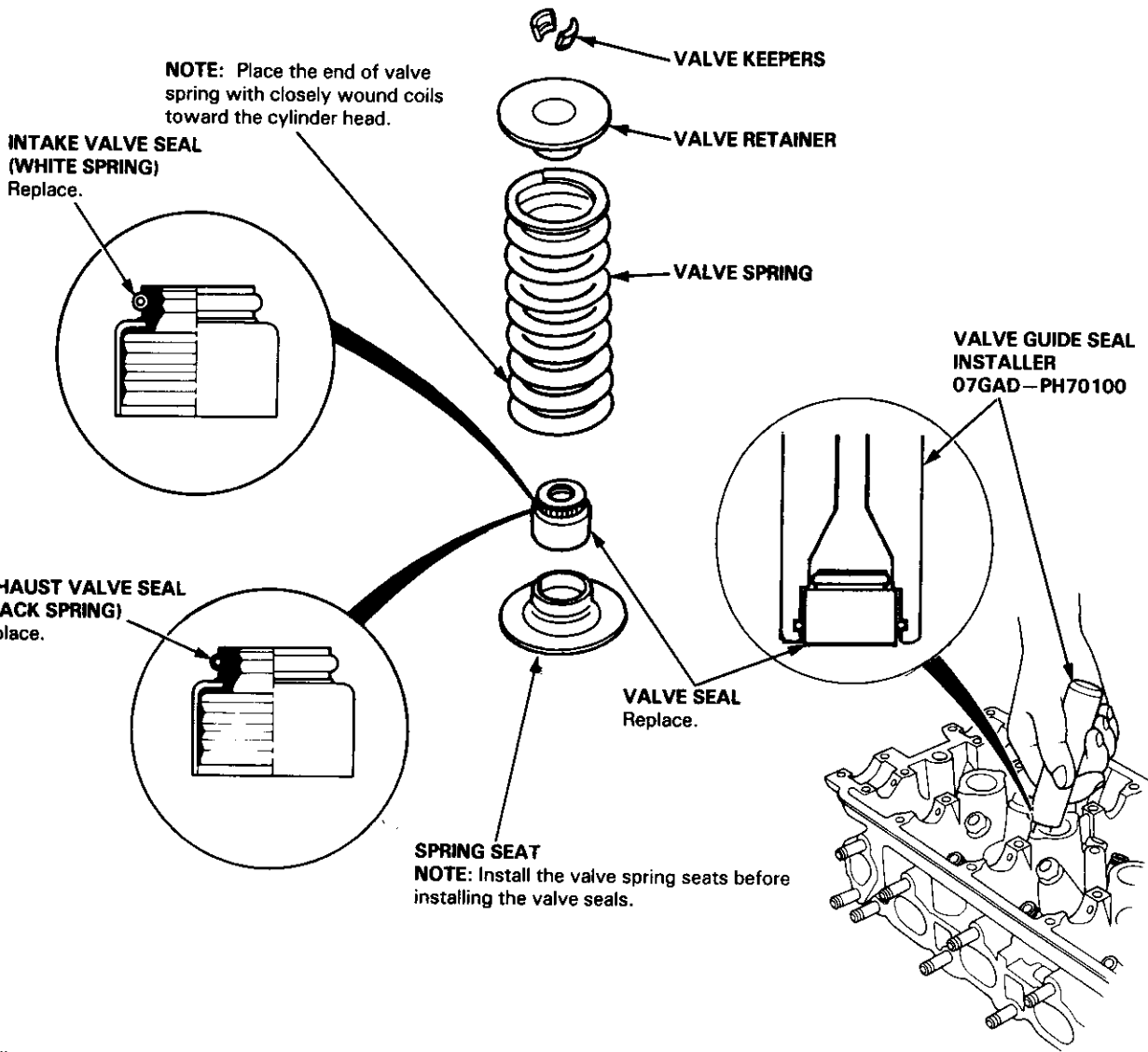

Valve Installation

When installing valves in cylinder head, coat valve stems with oil before inserting into valve guides, and make sure valves move up and down smoothly.

When valves and springs are in place, lightly tap the end of each valve stem two or three times with a plastic mallet to ensure proper seating of valve and valve keepers.

NOTE: Tap the valve stem only along its axis so you do not bend the stem.

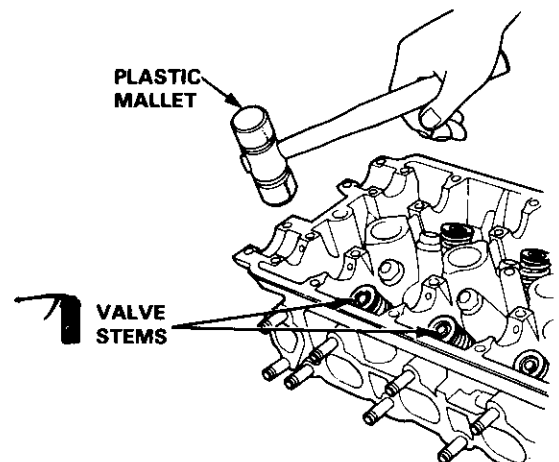

Cylinder Head

Installation

Install the cylinder head in the reverse order of removal:

NOTE:

- Always use a new head gasket.
- Cylinder head and engine block surface must be clean.
- "UP" marks on camshaft pulleys should be at the top.
- Turn the crankshaft so the No. 1 piston is at TDC (page 6-62).
- Clean the oil control orifice before installing.

1. Cylinder head dowel pins and oil control orifice must be aligned.

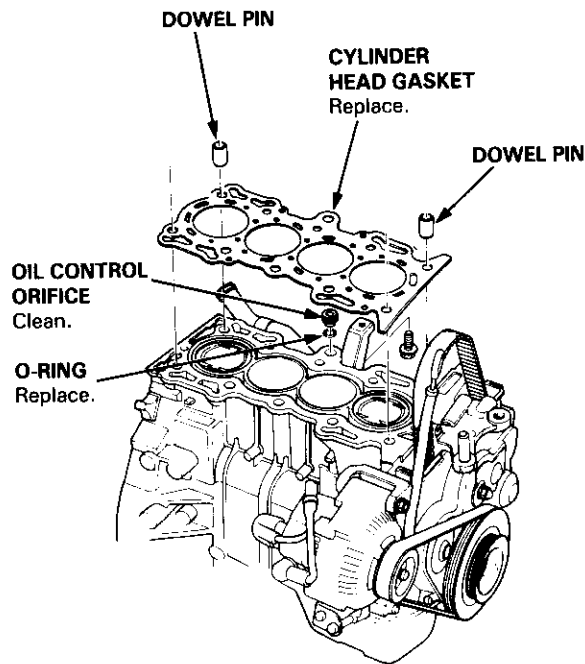

2. Tighten the cylinder head bolts sequentially in three steps.

1st step torque: 40 N·m (4.0 kg·m, 29 lb·ft)

2nd step torque: 70 N·m (7.0 kg·m, 51 lb·ft)

3rd step torque: 100 N·m (10.0 kg·m, 72 lb·ft)

NOTE:

- We recommend using a beam-type torque wrench. When using a preset-type torque wrench, be sure to tighten slowly and not to overtighten.
- If a bolt makes any noise while you are torquing it, loosen the bolt and retighten it from the 1st step.

CYLINDER HEAD BOLTS TORQUE SEQUENCE

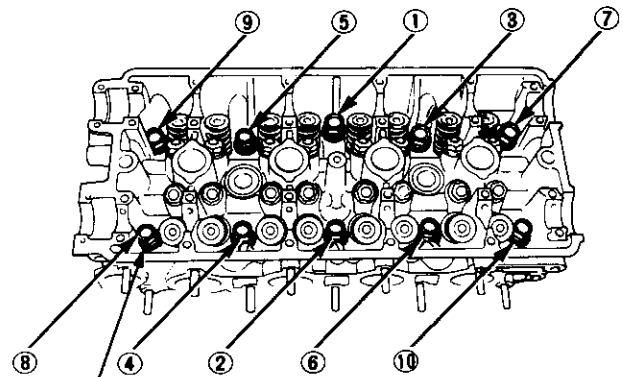

CYLINDER HEAD BOLTS

12 x 1.25 mm

100 N·m (10.0 kg·m, 72 lb·ft)

Apply clean engine oil bolt threads and under bolt heads.

Rocker Arms/Camshafts and Seals/Pulleys



3. Install the intake manifold and tighten the nuts in a criss-cross pattern in 2 or 3 steps, beginning with the inner nuts.

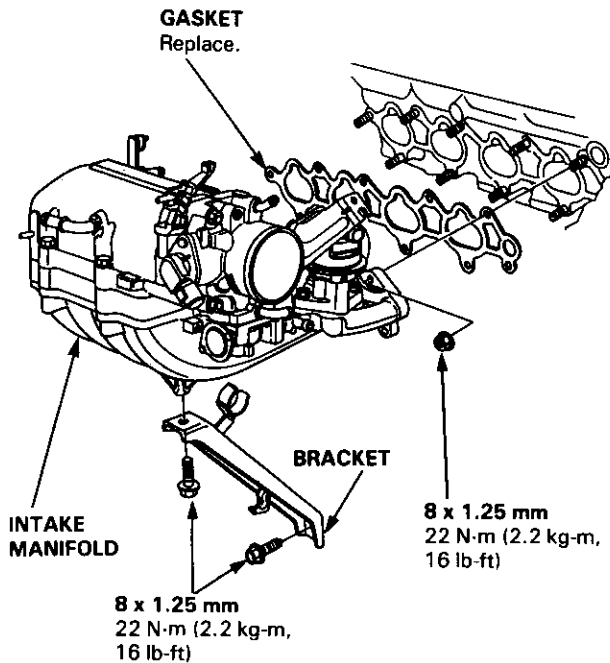

4. Install the exhaust manifold and bracket. Tighten the nuts in a criss-cross pattern in 2 or 3 steps, beginning with the inner nuts.

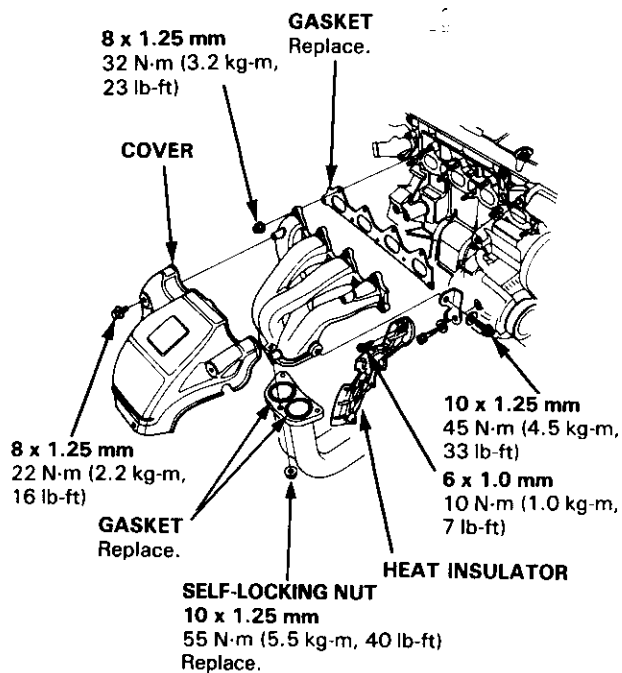

Installation

CAUTION:

- Make sure that the keyways on the camshafts are facing up. (No. 1 piston TDC).
- Valve locknuts should be loosened and before screws backed off before installation.
- Replace the rocker arms in their original positions.

1. Place the rocker arms on the pivot bolts and the valve stems.
2. Install the camshafts and the camshaft seals with the open side (spring) facing in.

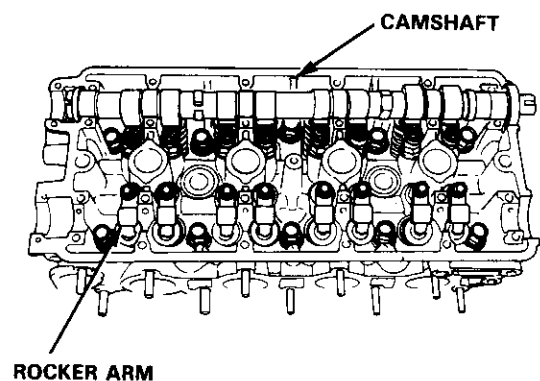

3. Apply liquid gasket to the head mating surfaces of the No. 1 and No. 6 camshaft holders, then install them, along with No. 2, 3, 4 and 5.

NOTE:

- "I" or "E" marks are stamped on the camshaft holders.
- Do not apply oil to the holder mating surface of camshaft seals.
- Apply liquid gasket to the shaded areas.
- The arrows marked on the camshaft holders should point toward the timing belt.

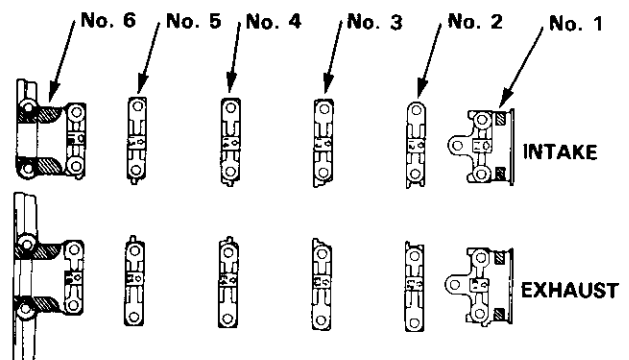

(cont'd)

Rocker Arms/Camshafts and Seals/Pulleys

Installation (cont'd)

4. Tighten the camshaft holders temporarily.
 - Make sure that the rocker arms are properly positioned on the valve stems.

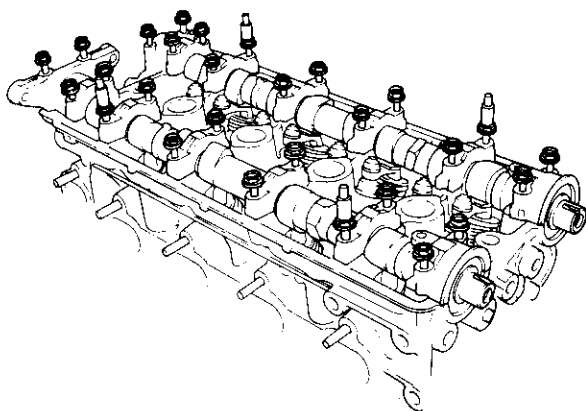

5. Press in the camshaft seals securely.

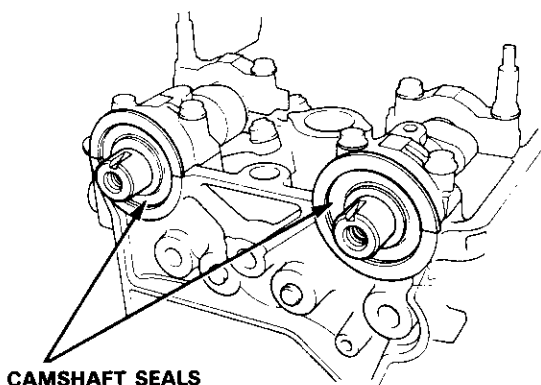

CAMSHAFT SEALS

6. Tighten each bolt in two steps to ensure that the rockers do not bind on the valves.

Specified Torque: Intake
 Except ⑤, ⑦: 10 N·m (1.0 kg-m, 7 lb-ft)
 ⑤, ⑦: 12 N·m (1.2 kg-m, 9 lb-ft)

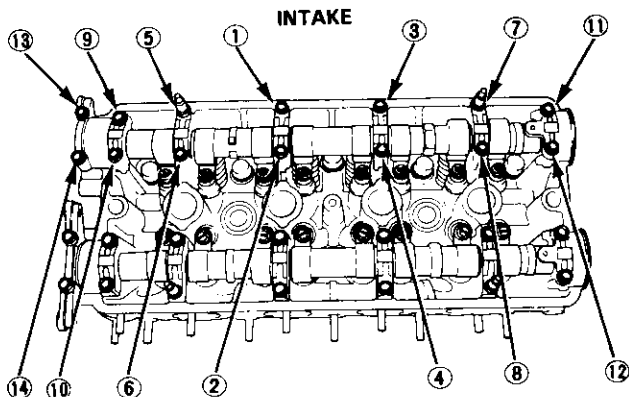

INTAKE

Specified Torque: Exhaust
 Except ⑥, ⑧: 10 N·m (1.0 kg-m, 7 lb-ft)
 ⑥, ⑧: 12 N·m (1.2 kg-m, 9 lb-ft)

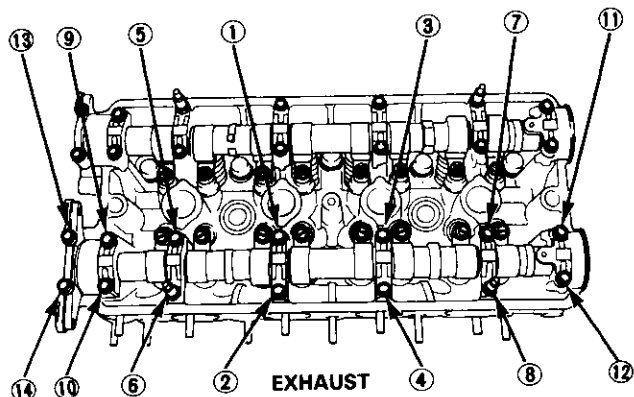

EXHAUST

7. Install the back cover.
8. Install keys into camshaft grooves.

NOTE: To set the camshafts at TDC position for No. 1 piston, align the holes in the camshafts with the holes in No. 1 camshaft holders and insert 5.0 mm pin punches in the holes.

PIN PUNCHES, 5.0 mm

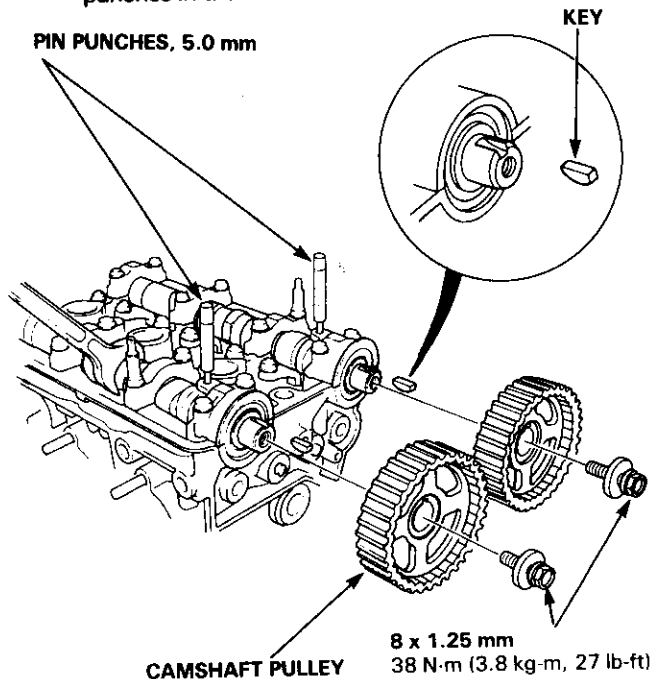

CAMSHAFT PULLEY

8 x 1.25 mm
 38 N·m (3.8 kg-m, 27 lb-ft)

9. Push camshaft pulleys onto camshafts, then tighten the retaining bolts to the torque specified.
10. Adjust the valve clearance (page 6-68).
11. After installation, check that all tubes, hoses and connectors are installed correctly.



Timing Belt and Timing Balancer Belt

Illustrated Index

NOTE:

- Refer to page 6-62 for positioning crankshaft and pulley before installing timing belt.
- Before removing, mark direction of rotation on each belt.

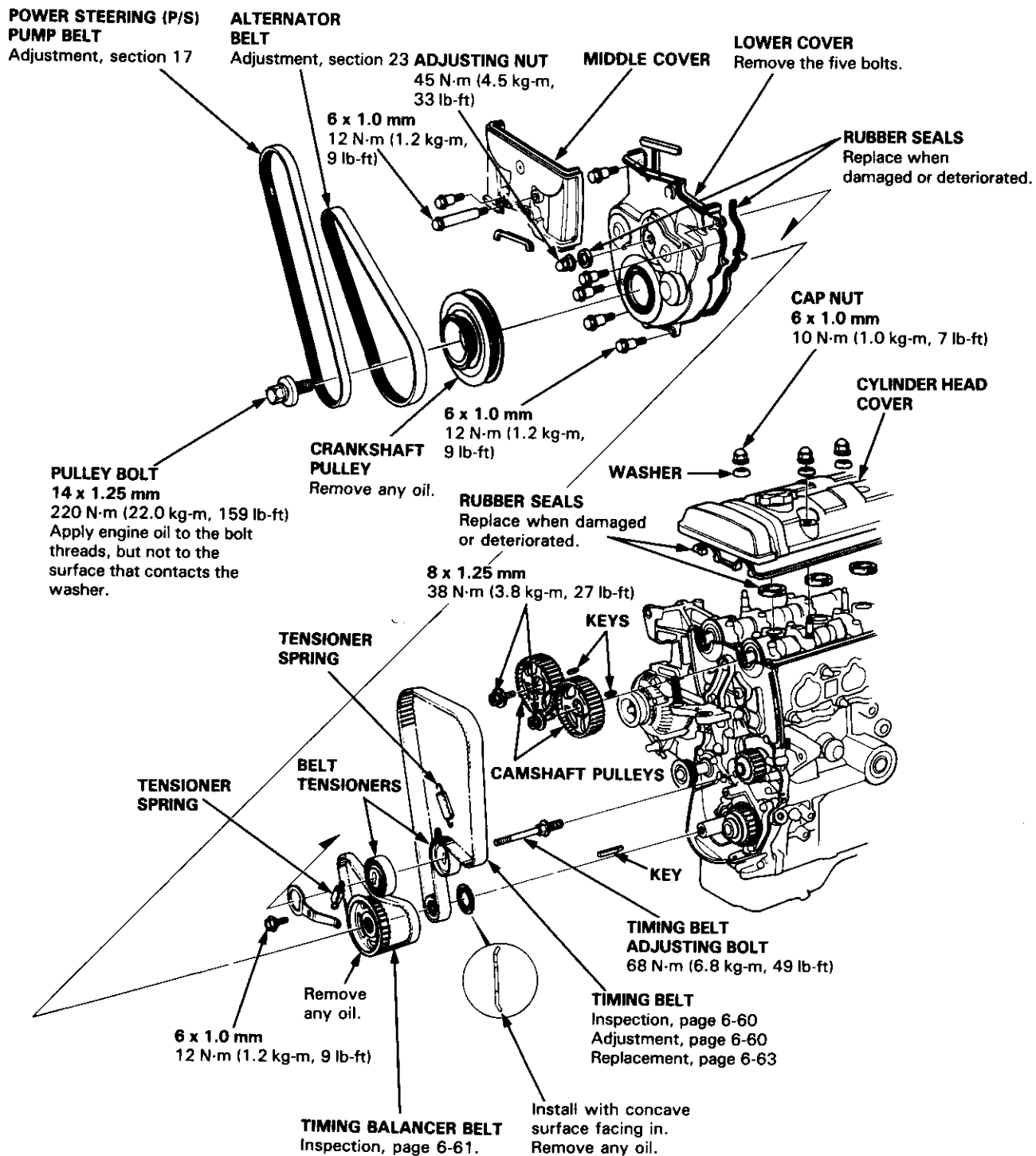

Timing Belt

Inspection

1. Disconnect the alternator terminal and the connector, then remove the engine wire harness from the cylinder head cover.
2. Remove the cylinder head cover.
3. Remove the middle cover.
4. Inspect the timing belt for cracks and oil or coolant soaking.

NOTE:

- Replace the belt if oil or coolant soaked.
- Remove any oil or solvent that gets on the belt.

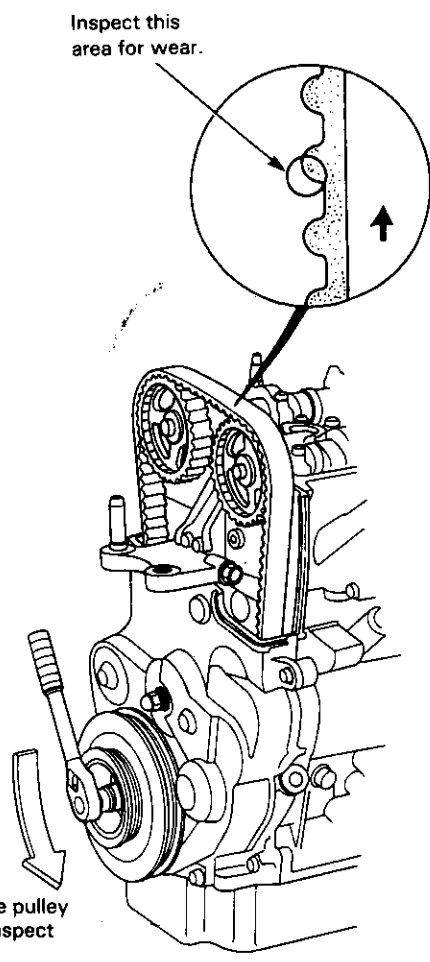

5. After inspecting, retorque the crankshaft pulley bolt to 220 N·m (22.0 kg·m, 159 lb·ft).

Tension Adjustment

CAUTION: Always adjust timing belt tension with the engine cold.

NOTE:

- The tensioner is spring-loaded to apply proper tension to the belt automatically after making the following adjustment.
- Always rotate the crankshaft counterclockwise when viewed from the pulley side. Rotating it clockwise may result in improper adjustment of the belt tension.
- Inspect the timing balancer belt before adjusting the belt tension.
- Do not loosen the adjusting nut more than one full turn.

1. Disconnect the alternator terminal and the connector, then remove the engine wire harness from the cylinder head cover.
2. Remove the cylinder head cover.
3. Set the No. 1 piston at TDC (page 6-62).
4. Loosen the adjusting nut 2/3-1 turn, then tighten it.

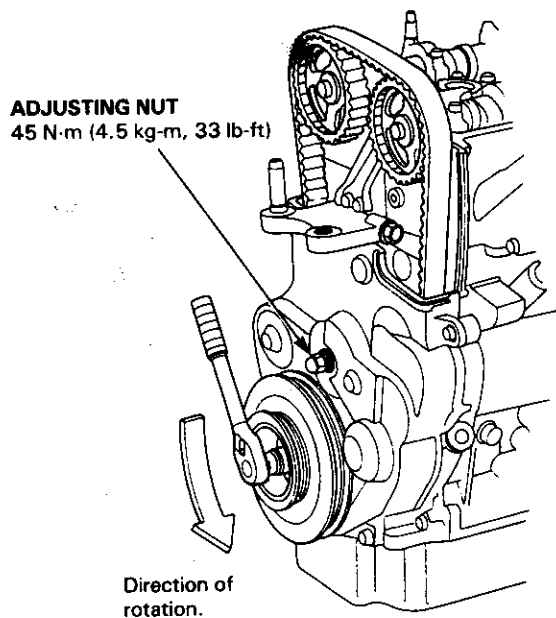

5. Rotate the crankshaft counterclockwise 3-teeth on the camshaft pulley, then reloosen the adjusting nut to create tension on the timing belt.
6. Tighten the adjusting nut.
7. After adjusting, retorque the crankshaft pulley bolt to 220 N·m (22.0 kg·m, 159 lb·ft).



Timing Balancer Belt

Inspection

1. Disconnect the alternator terminal and the connector, then remove the engine wire harness from the cylinder head cover.
2. Remove the cylinder head cover.
3. Remove the middle cover.
4. Remove the crankshaft pulley.
5. Remove the lower cover.
6. Install the crankshaft pulley.
7. Inspect the timing belt for cracks and oil or coolant soaking.

NOTE:

- Replace the belt if oil or coolant soaked.
- Remove any oil or solvent that gets on the belt.

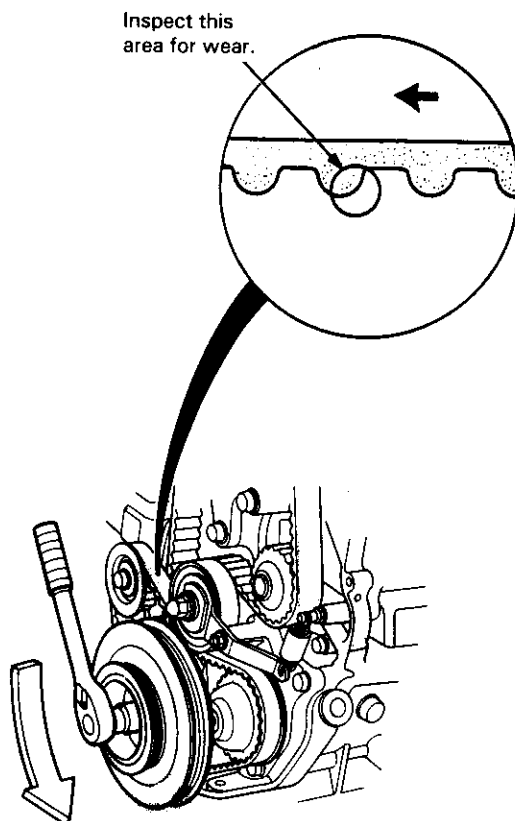

Rotate pulley
and inspect belt.

8. After inspecting, retorque the crankshaft pulley bolt to 220 N·m (22.0 kg·m, 159 lb·ft).

NOTE: Refer to page 6-66 for timing balancer belt tension adjustment.

Timing Belt

Positioning Crankshaft Before Installing Timing Belt.

NOTE:

- Install the timing belt with the No. 1 piston at TDC.
- After installing, retorque the crankshaft pulley bolt to 220 N·m (22.0 kg-m, 159 lb-ft).

CRANKSHAFT TDC POSITION:

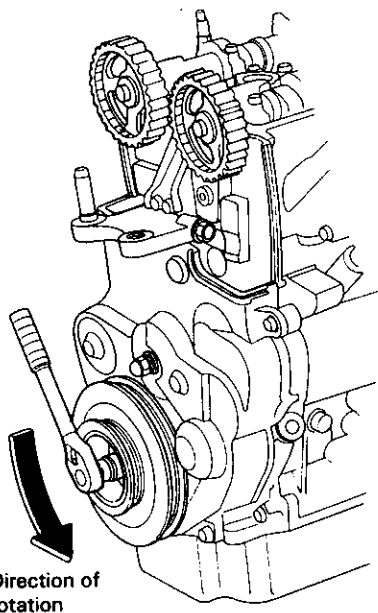
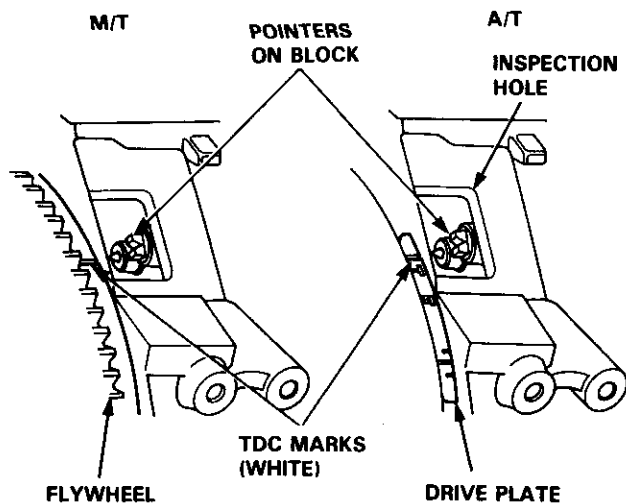

NOTE: When turning the crankshaft with a socket wrench, install the crankshaft pulley and the pulley bolt.

CAMSHAFT TDC POSITION:

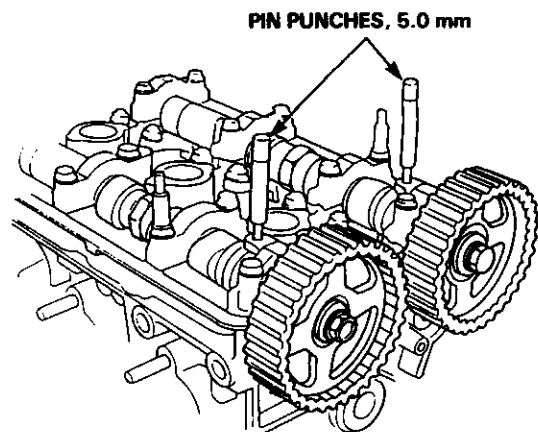
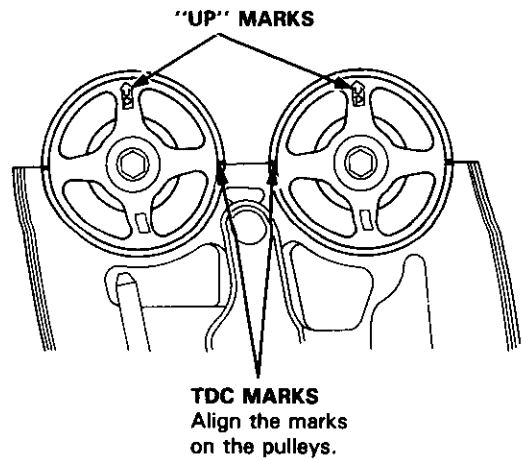

CAUTION: Remove the pin punches after installing the timing belt.



Timing Belt and Timing Balancer Belt

Replacement

CAUTION: Inspect the water pump when replacing the timing belt (page 10-12).

NOTE: Turn the crankshaft so that the No. 1 piston is at TDC (page 6-62).

1. Remove the splash shield.

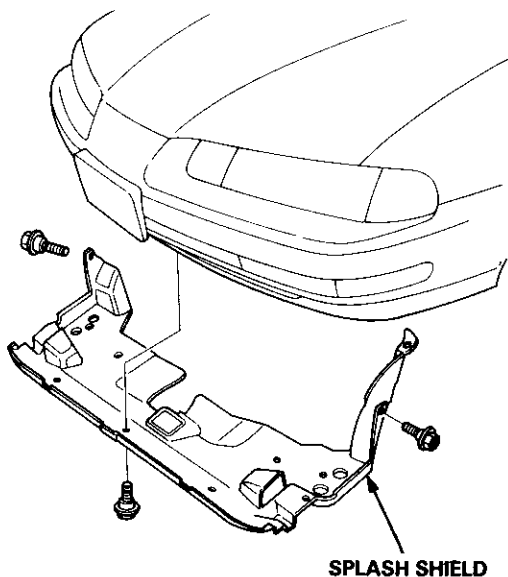

2. Disconnect the connector, then remove the cruise control actuator.

NOTE:

- Do not disconnect the control cable.
- Take care not to bend the cable when removing the actuator. Always replace a kinked cable with a new one.

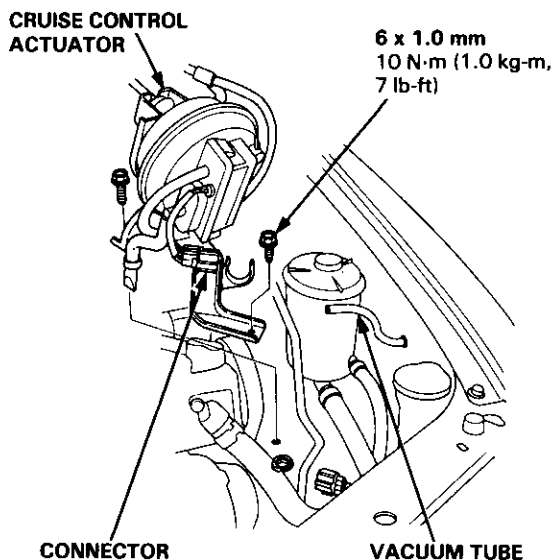

3. Remove the mounting bolts, nuts and poly-V-belt from the power steering (P/S) pump.

NOTE:

- Do not disconnect the P/S pipe and hose.
- After installing, adjust the tension of the P/S pump belt (see section 17).

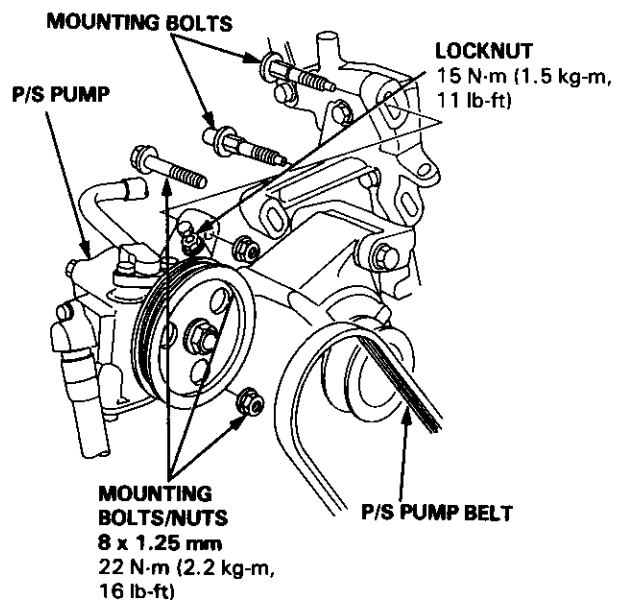

4. Disconnect the alternator terminal and the connector, then remove the engine wire harness from the cylinder head cover.

5. Loosen the alternator mounting bolt, nut and the adjusting bolt, then remove the alternator belt.

NOTE: After installing, adjust the tension of the alternator belt (see section 23).

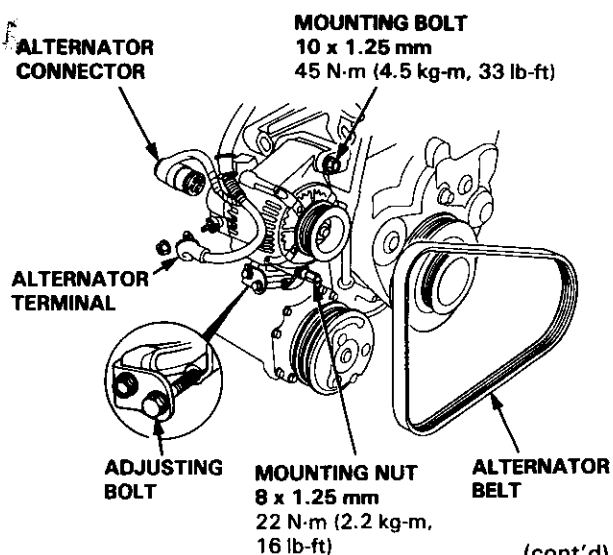

(cont'd)

Timing Belt and Timing Balancer Belt

Replacement (cont'd)

6. Remove the cylinder head cover.
7. Remove the middle cover.
8. Remove the side engine mount.
9. Remove the dipstick and the pipe.
10. Remove the pulley bolt and the crankshaft pulley. Remove the two rear bolts from the center beam to allow the engine to drop down and give clearance to remove the lower cover.
11. Remove the rubber seal around the adjusting nut. Do not loosen the adjusting nut.
12. Remove the lower cover.

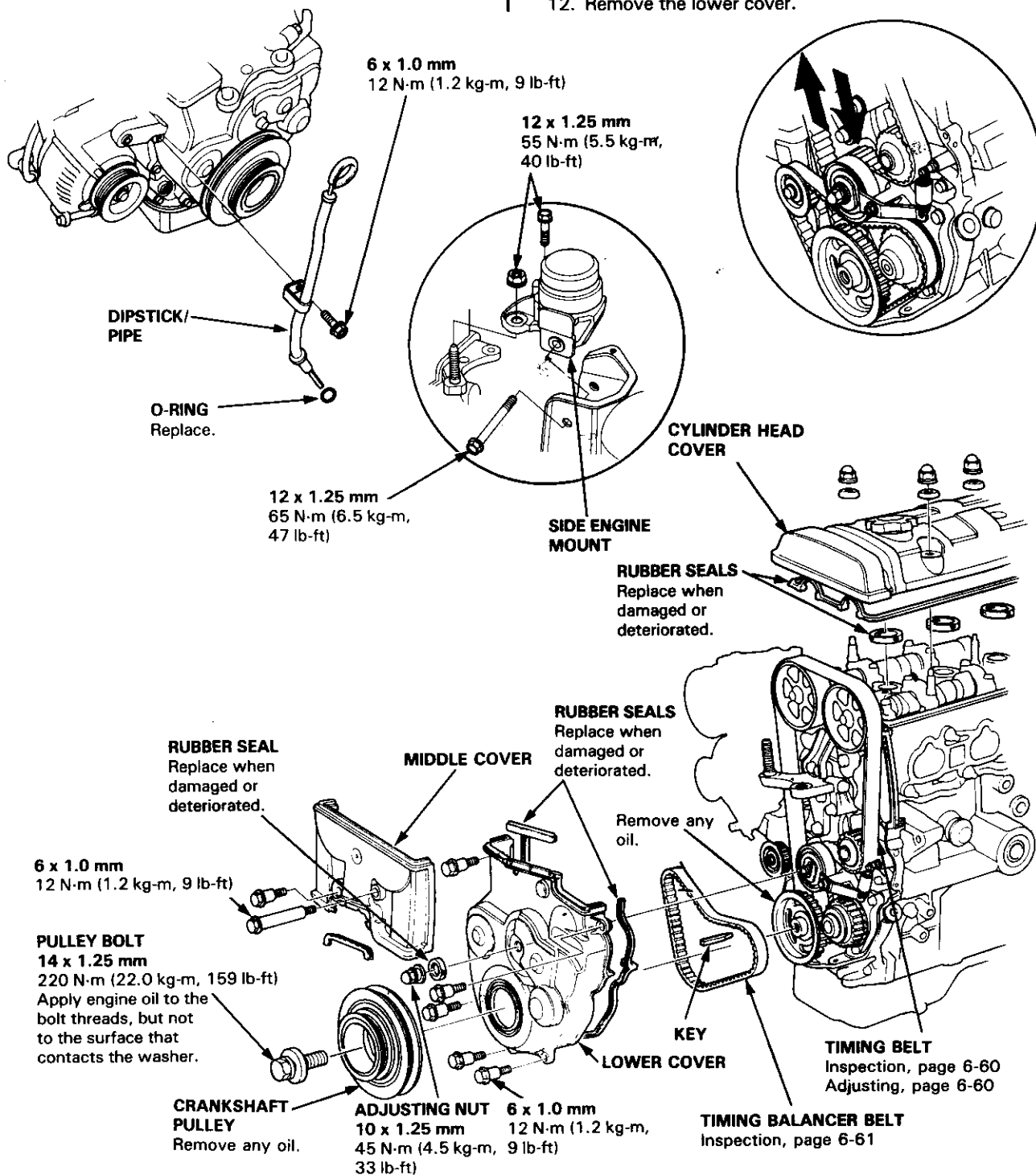



13. Lock the timing belt adjuster arm in place by installing one of the 6 x 1.0 mm lower cover mounting bolts.
14. Loosen the timing belt adjusting nut. Push on the pulley to remove tension from the timing balancer belt, then tighten the adjusting nut.
15. Remove the timing balancer belt.

NOTE: If you are removing only the timing balancer belt, go to step 21. If you are removing both belts, continue with this procedure.

16. Loosen 6 x 1.0 mm lock bolt and the adjusting nut. Push on the timing belt adjuster pulley to remove tension from the belt, then tighten the adjusting nut.
17. Remove the timing belt.
18. Install the timing belt in the reverse order of removal.
 - Before installing the timing belt, position the crankshaft and camshaft pulleys as shown on page 6-62.
19. Perform the timing belt tension adjustment (page 6-60).
20. Tighten the 6 x 1.0 mm bolt to lock the timing belt adjuster arm.

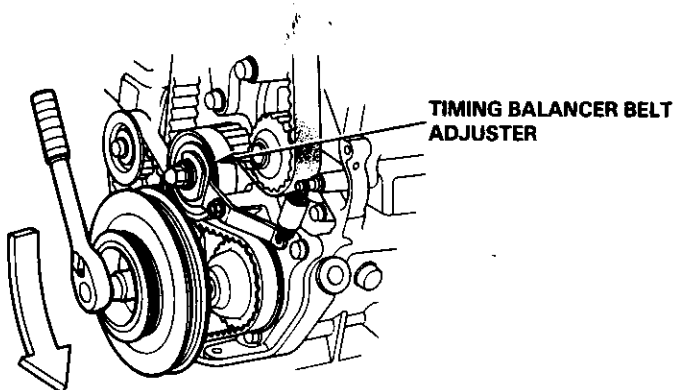
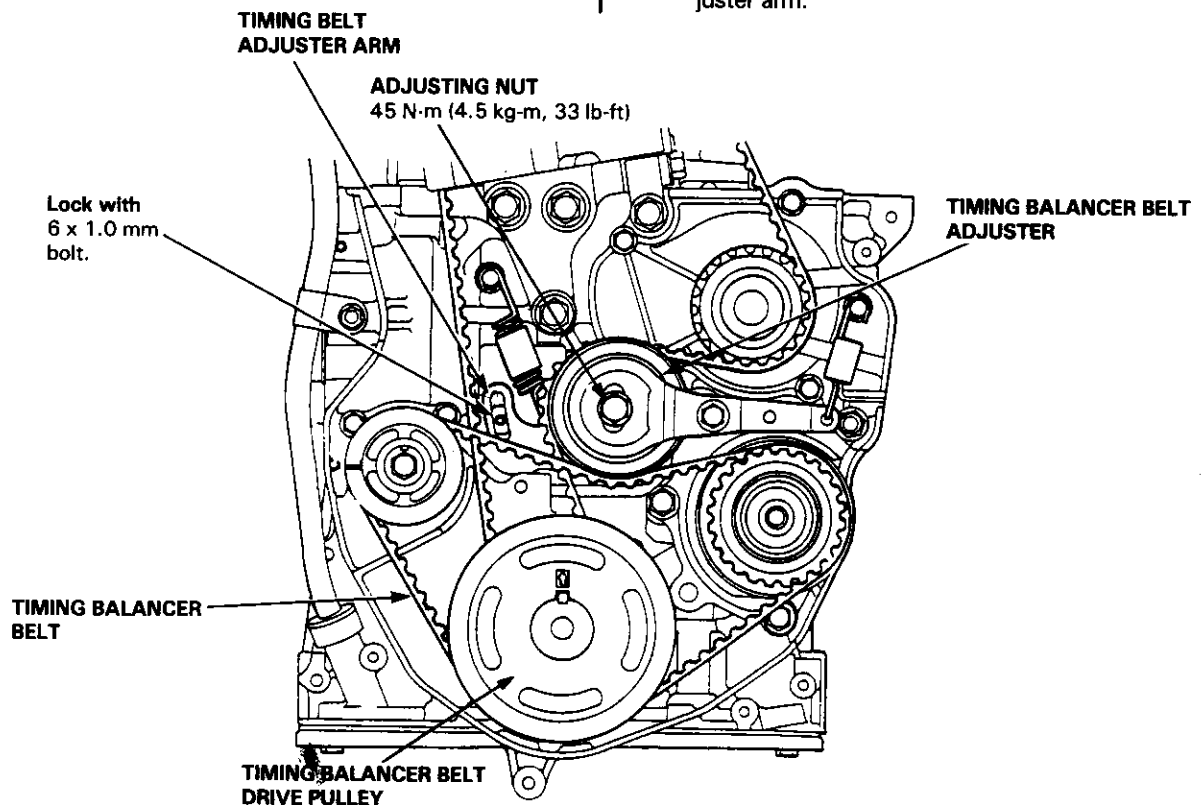

(cont'd)

Timing Belt and Timing Balancer Belt Replacement (cont'd)

21. Make sure the crankshaft is positioned with the No. 1 piston at TDC.
22. Align the groove on the front balancer shaft pulley with the pointer on the oil pump housing as shown.
23. Align the rear balancer shaft pulley by using a 6 x 100 mm bolt or equivalent as an alignment tool. Scribe a line 74 mm (2.9 in) from the end of the bolt. Insert the bolt into the maintenance hole to the scribed line.
24. Loosen the adjusting nut and verify that the timing balancer belt adjuster moves freely.
25. Install the timing balancer belt. Remove the 6 x 100 mm bolt from the rear balancer shaft.

26. Turn the crankshaft pulley about one turn counterclockwise, then tighten the adjusting nut to the specified torque.

NOTE: Both belt adjusters are spring-loaded to properly tension the belts. Do not apply any extra pressure to the pulleys or tensioners while performing the adjustment.

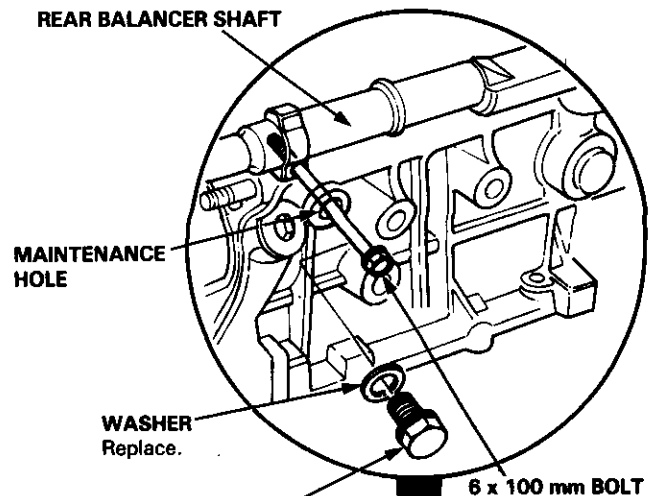
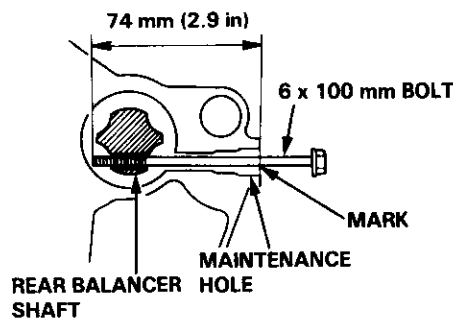

12 mm SEALING BOLT
30 N·m (3.0 kg-m, 22 lb-ft)
NOTE: Tighten the bolt after installing the belt.

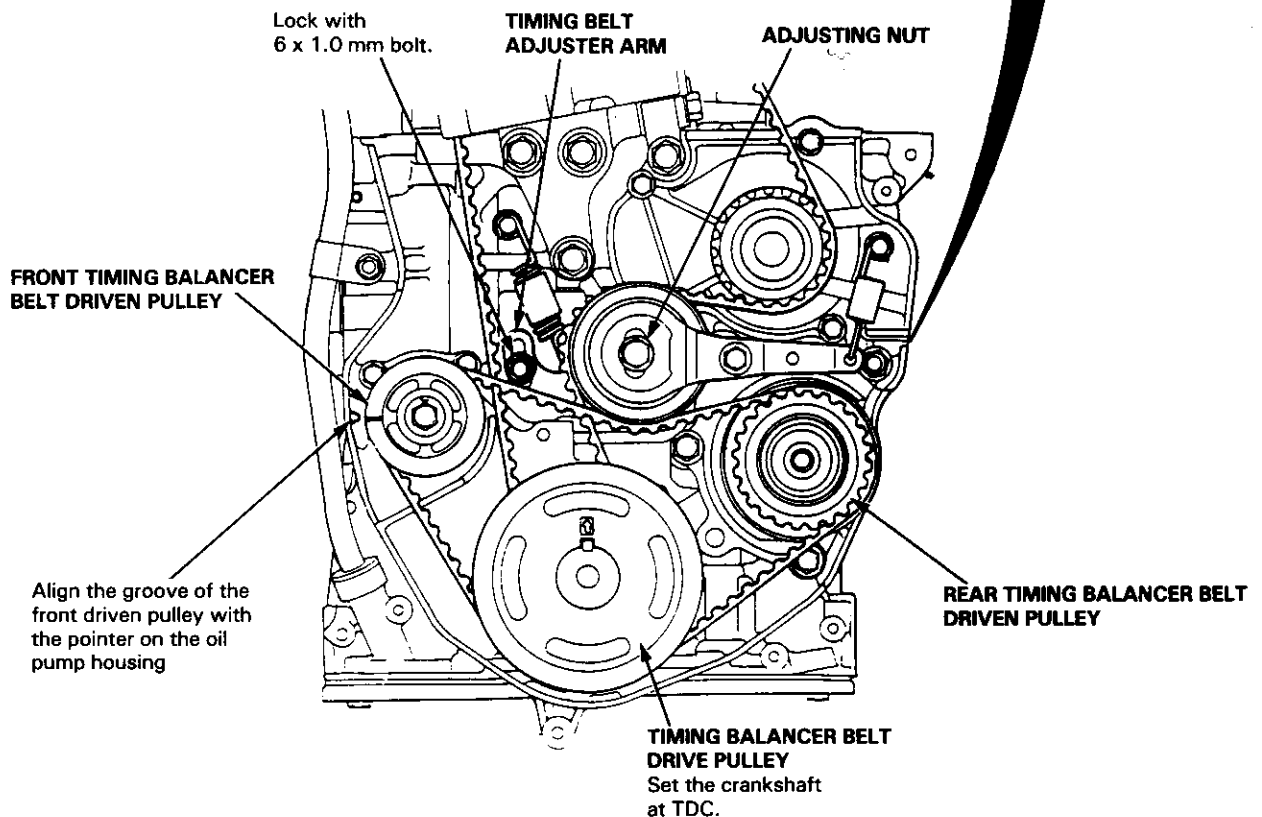



27. Remove the 6 x 1.0 mm bolt from the timing belt adjuster arm.
28. Remove the crankshaft pulley.
29. Install the lower cover.
30. Install a rubber seal around the adjusting nut. Do not loosen the nut.

31. Install the middle cover.
32. Install the crankshaft pulley.
33. Coat the threads and seating face of the pulley bolt with engine oil. Install and tighten to the specified torque.

Specified torque: 220 N·m (22.0 kg-m, 159 lb-ft)

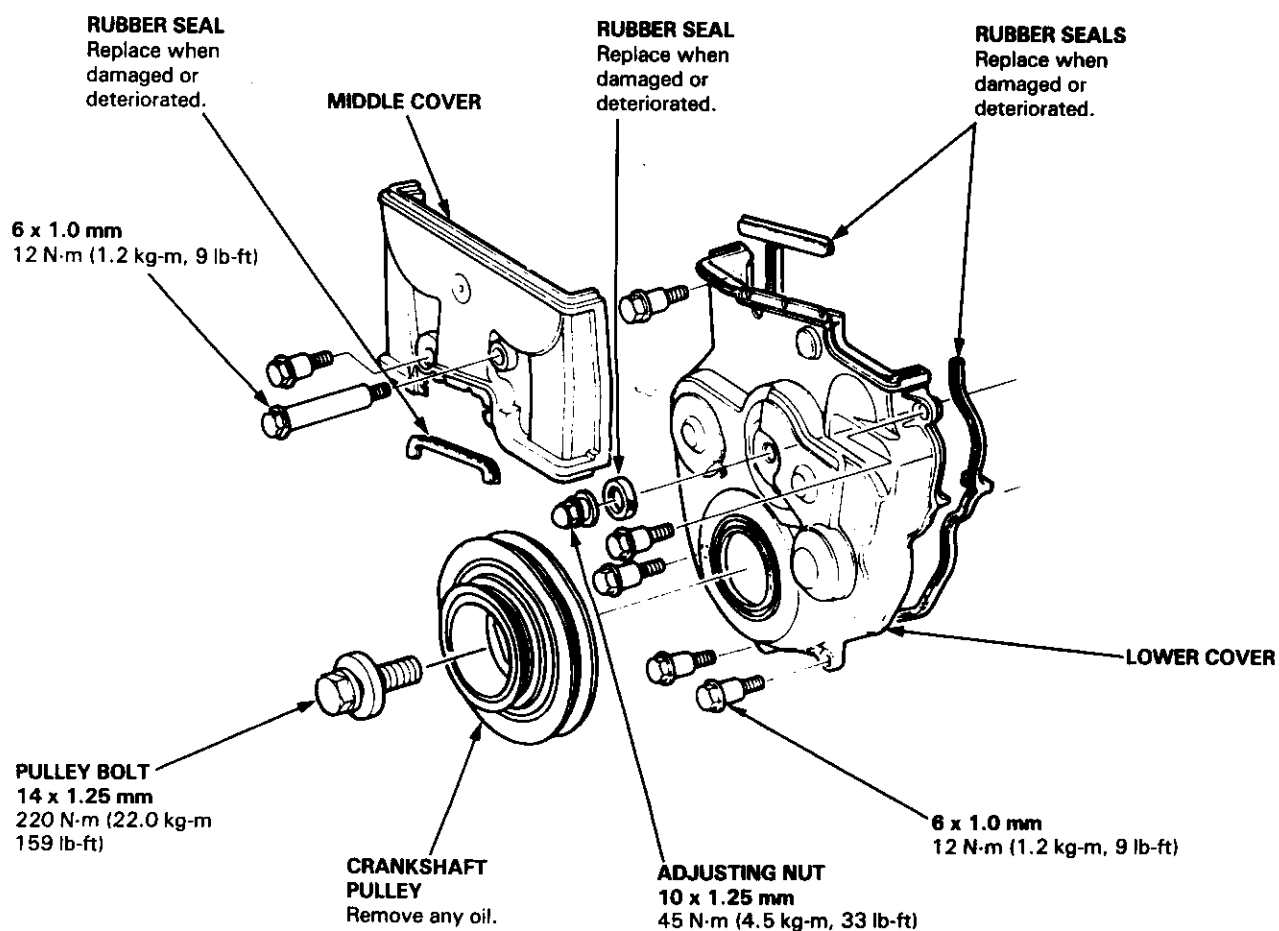

Valve Clearance

Adjustment

NOTE:

- Valves should be adjusted cold when the cylinder head temperature is less than 100°F (38°C).
- After adjusting, retorque the crankshaft pulley bolt to 220 N·m (22.0 kg·m, 159 lb·ft)

1. Remove the cylinder head cover.

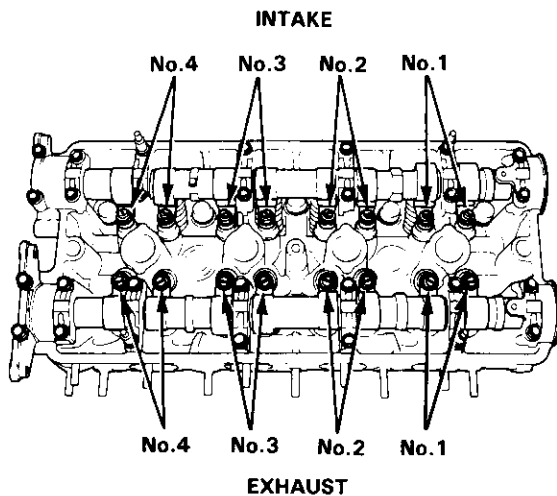

2. Set No. 1 piston at TDC. "UP" marks on the camshaft pulleys should be at top, and TDC grooves on the camshaft pulleys should align with cylinder head surface.

Number 1 piston at TDC:

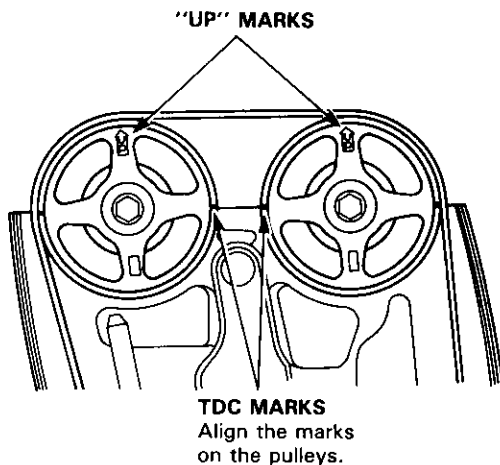

3. Adjust valves on No. 1 cylinder.

Valve Clearance:

Intake: 0.07–0.11 mm (0.003–0.004 in)

Exhaust: 0.15–0.19 mm (0.006–0.007 in)

4. Loosen locknut and turn adjusting screw until feeler gauge slides back and forth with slight amount of drag.

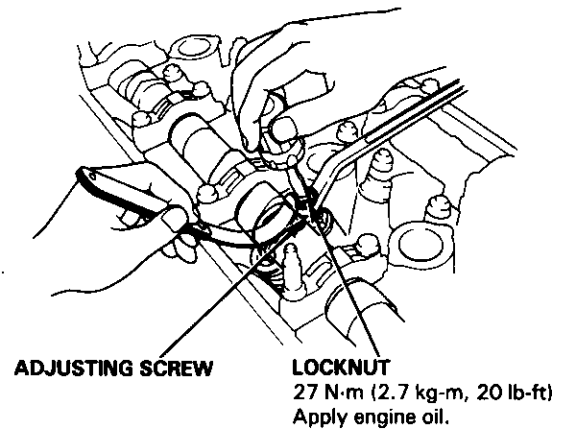

5. Tighten the locknut and check clearance again. Repeat adjustment if necessary.

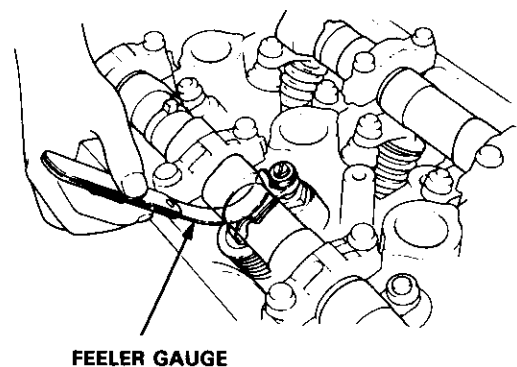



6. Rotate crankshaft 180° counterclockwise (Camshaft pulleys turns 90°). The "UP" marks should be at exhaust side. Adjust valves on No. 3 cylinder.

Number 3 piston at TDC:

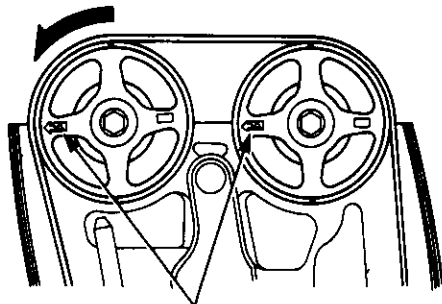

"UP" MARKS

8. Rotate crankshaft 180° counterclockwise to bring No.2 piston to TDC. The "UP" marks should be at intake side. Adjust valves on No. 2 cylinder.

Number 2 piston at TDC:

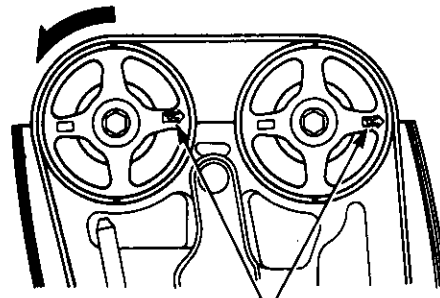

"UP" MARKS

7. Rotate crankshaft 180° counterclockwise to bring No. 4 piston to TDC. the TDC grooves are once again aligned. Adjust valves on No. 4 cylinder.

Number 4 piston at TDC:

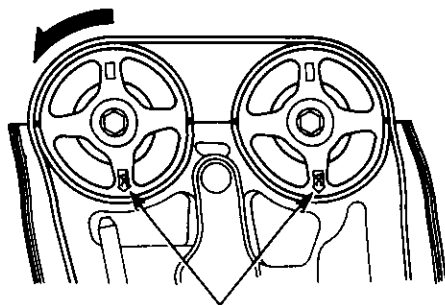

"UP" MARKS

Cylinder Head/Valve Train (H22A1 engine)

Special Tools	6-72	Camshafts	
Illustrated Index	6-73	Inspection	6-93
VTEC		Valves, Valve Springs and Valve Seals	
Troubleshooting Flowchart —		Removal	6-95
VTEC Solenoid Valve	6-75	Valve Spring and Valve Seal	
VTEC Pressure Switch.....	6-77	Installation Sequence.....	6-101
VTEC Solenoid Valve Inspection.....	6-80	Valve Installation	6-102
Rocker Arms		Valve Seats	
Manual Inspection.....	6-81	Reconditioning	6-97
Inspection Using Special Tools.....	6-81	Valve Guides	
Inspection	6-92	Valve Movement	6-98
Cylinder Head		Replacement.....	6-99
Removal	6-83	Reaming	6-100
Warpage.....	6-98	Timing Belt and Timing Balancer Belt	
Installation	6-103	Illustrated Index.....	6-107
Rocker Arms and Shafts		Replacement.....	6-109
Removal	6-88	Timing Belt	
Locations	6-90	Inspection	6-108
Clearance.....	6-91	Timing Balancer Belt	
Installation	6-102	Inspection	6-108
Lost motion Assemblies		Valve Clearance	
Inspection	6-92	Adjustment	6-115



Special Tools

Ref. No.	Tool Number	Description	Qty	Page Reference
①	07HAH-PJ7010A or 07HAH-PJ7010B	Valve Guide Reamer, 5.5 mm	1	6-100
②	07LAJ-PR3020A	Air Stopper	1	6-81, 82
③	07MAA-PR70110	Tappet Adjuster	1	6-115
④	07MAA-PR70120	Tappet Locknut Wrench	1	6-115
⑤	07MAF-PR9010A	Valve Spring Compressor Attachment Extension	1	6-95
⑥	07NAG-P130100	Timing Belt Slider	1	6-106
⑦	07742-0010100	Valve Guide Driver, 5.5 mm	1	6-99, 100
⑧	07757-PJ1010A	Valve Spring Compressor Attachment	1	6-95



①



②



③

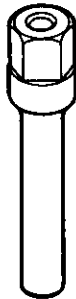

④

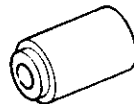

⑤

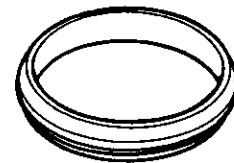

⑥

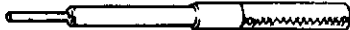

⑦

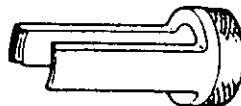

⑧

Illustrated Index



CAUTION: To avoid damaging the cylinder head, wait until the engine coolant temperature drops below 100°F (38°C) before removing it.

NOTE:

- Use new O-rings and gaskets when reassembling.
- Use liquid gasket, Part No. 08740-0001.
- Clean the oil control orifice before installing.

 Prior to reassembling, clean all the parts in solvent, dry them, and apply lubricant to any contact parts.

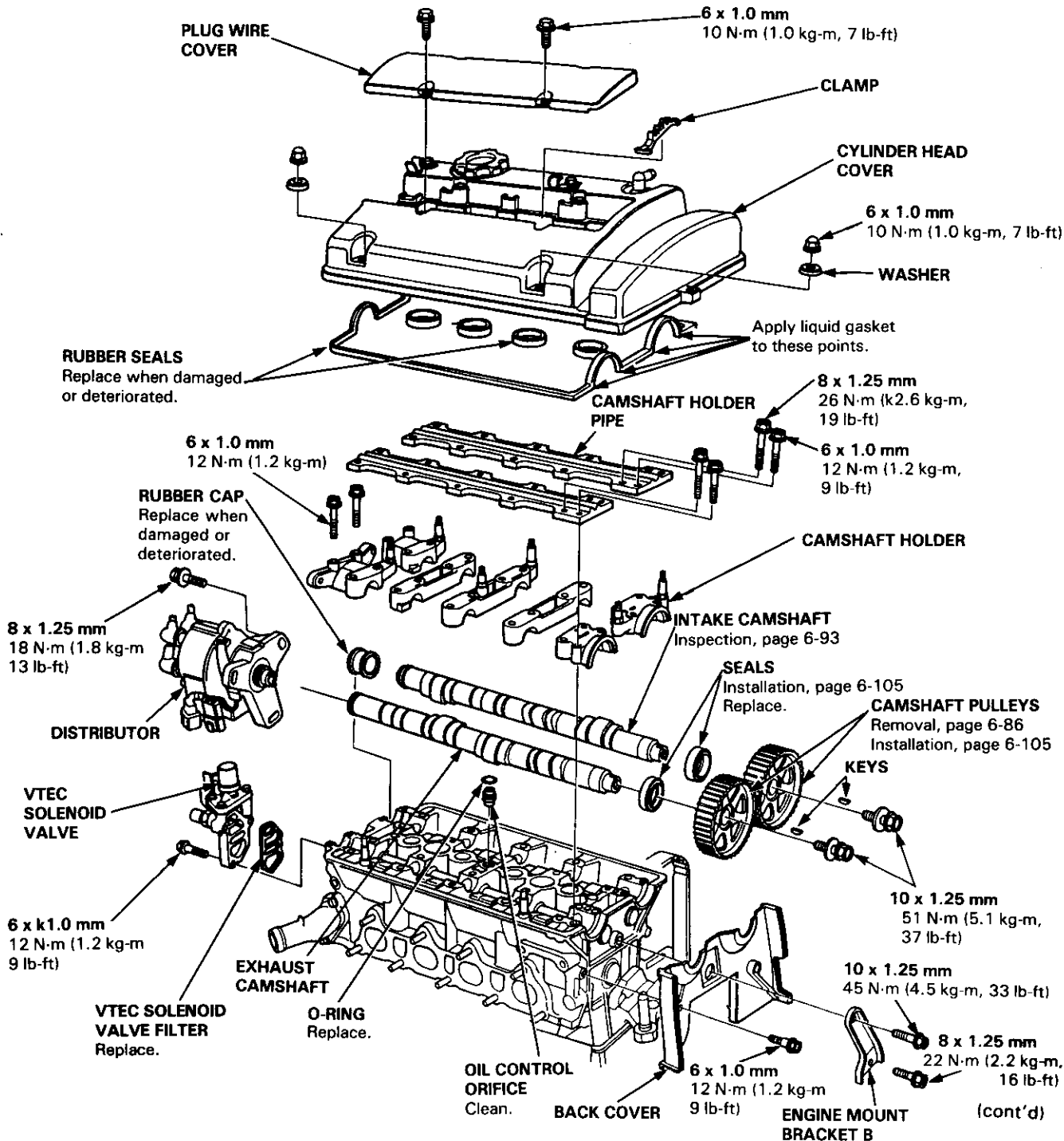

Illustrated Index

(cont'd)

NOTE: Clean the rocker shaft orifices when installing.

CYLINDER HEAD BOLTS
12 x 1.25 mm
100 N-m (10.0 kg-m, 72 lb-ft)
Apply clean engine oil to threads and under the bolt heads.

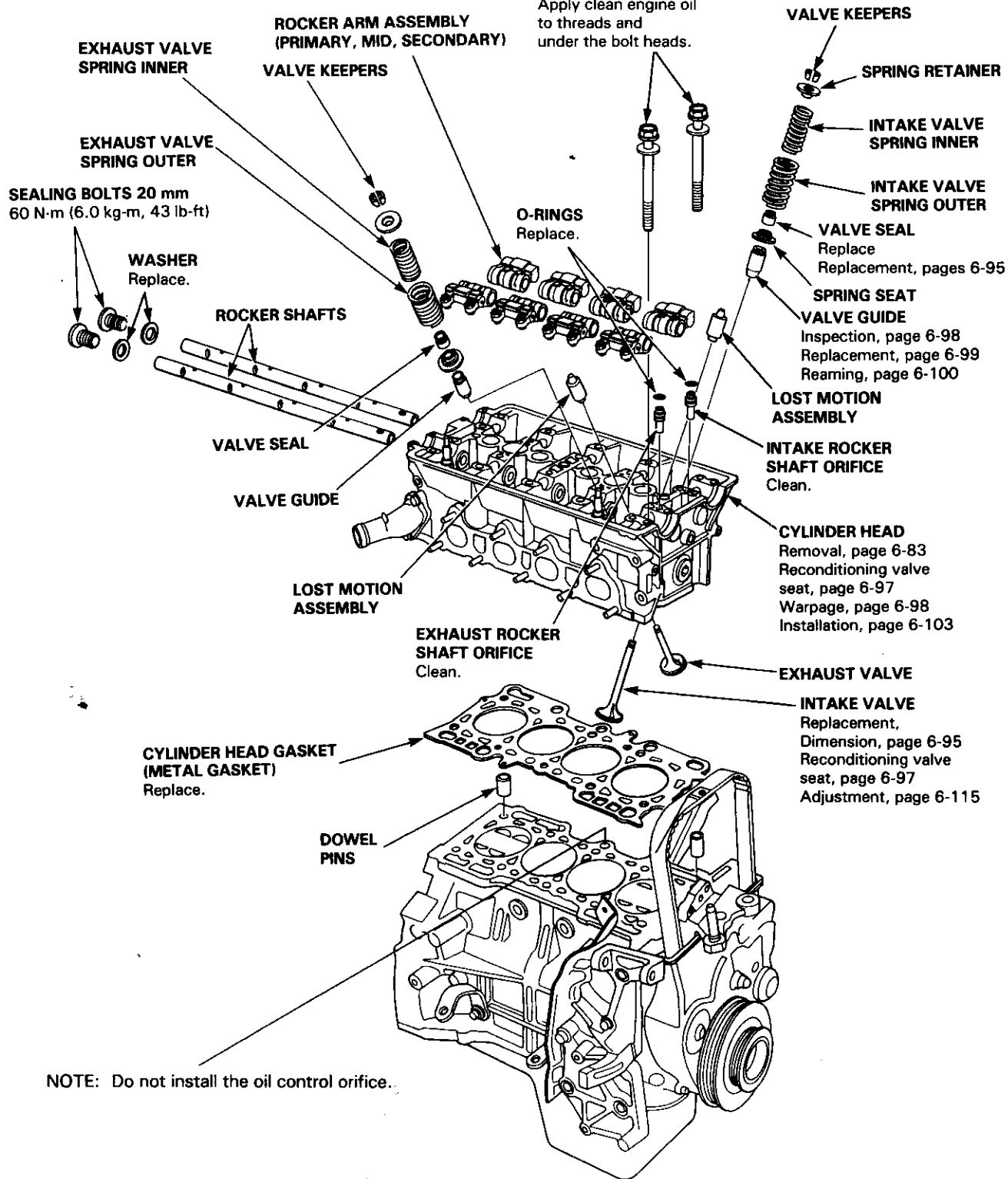

NOTE: Do not install the oil control orifice.



VTEC

Troubleshooting Flowchart — VTEC Solenoid Valve



21

Malfunction Indicator Lamp (MIL) indicates Diagnostic Trouble Code (DTC) 21: A problem in the VTEC Solenoid Valve circuit.



21

- MIL has been reported on.
- With service check connector jumped (page 11-42), code 21 is indicated.

Do the engine control module (ECM) Reset Procedure (page 11-43).

Start the engine.

Warm up engine to normal operating temperature (radiator fan comes on).

Do the Road Test.*

*Road Test:

Accelerate in 2nd gear to an engine speed over 6000 rpm. Hold that engine speed for at least two seconds. Repeat this test at least three times.

Is MIL on and does it indicate code 21?

NO

Intermittent failure, system is OK at this time. Check for poor connections or loose wires at VTEC solenoid valve and ECM.

YES

Turn the ignition switch OFF.

Disconnect the 1P connector from the VTEC solenoid valve.

Check for continuity between 1P connector terminal and body ground.

Is there 14-30Ω?

NO

Replace the VTEC solenoid valve.

YES

(To page 6-76)

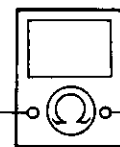
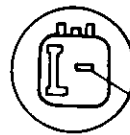
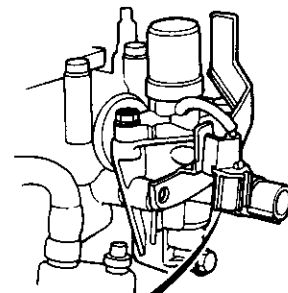

14-30Ω

(cont'd)

VTEC

Troubleshooting Flowchart—VTEC Solenoid Valve (cont'd)

(From page 6-75)

Reconnect 1P connector to VTEC solenoid valve. Connect the ECM test harness to the main harness only.

Measure the resistance between A4 terminal and A26 terminal.

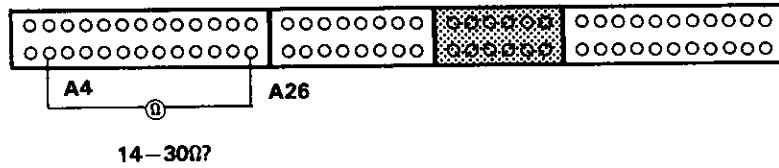

Is there 14-30 Ω?

NO

Check for open or short in wire between ECM and VTEC solenoid valve.

YES

Substitute a known-good ECM and recheck. If symptom/indication goes away replace the original ECM.



Troubleshooting Flowchart — VTEC Pressure Switch



22

Malfunction Indicator Lamp (MIL) indicates Diagnostic Trouble Code (DTC) 22: A problem in the VTEC Pressure Switch circuit.



22

— MIL has been reported on.
— With service check connector jumped (page 11-42). Code 22 is indicated.

Do the engine control module (ECM) Reset Procedure (page 11-43).

Start the engine.

Warm up engine to normal operating temperature (radiator fan comes on).

Do the Road Test.*

*Road Test:
Accelerate in 2nd gear to an engine speed over 6000 rpm.
Hold that engine speed for at least two seconds.
Repeat this test at least three times.

Is MIL on and does it indicate code 22?

NO

Intermittent failure, system is OK at this time.
Check for poor connections or loose wires at VTEC pressure switch and EM.

YES

Turn the ignition switch OFF.

Disconnect the 2P connector from the VTEC pressure switch.

Check for continuity between the 2 terminals on the VTEC pressure switch.

Is there continuity?

NO

Replace VTEC pressure switch.

YES

Turn the ignition switch ON.

Measure the voltage between the BLU/BLK wire and body ground.

(To page 6-78)

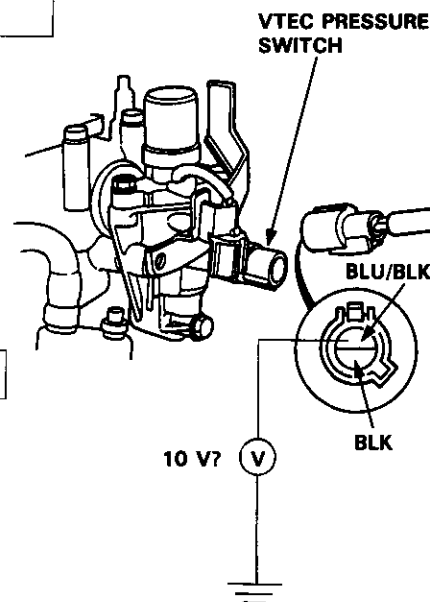

(cont'd)

VTEC

Troubleshooting Flowchart — VTEC Pressure Switch (cont'd)

(From page 6-77)

Is there approx. 10 V?

NO

Inspect for an open or short to ground in the BLU/BLK wire between the 2P connector and D6 terminal of the ECM. If wire is OK, substitute a known-good ECM and retest.

YES

Measure the voltage across the BLU/BLK and BLK wires in 2P connector.

Is there approx. 10 V?

NO

Repair open circuit in BLK wire between the 2P connector and body ground.

YES

Turn the ignition switch OFF.

Remove 10 mm sealing bolt and connect oil pressure gauge.

Connect a tachometer (see section 11).

Start the engine and warm it up to normal operating temperature.

Check oil pressure at engine speed of 1,000, 3,000 and 5,000 rpm.

Is pressure below 50 kPa (0.5 kg/cm², 7 psi)?

NO

Inspect the VTEC solenoid valve.

YES

Disconnect the 1P connector from the VTEC solenoid valve.

Attach the battery positive terminal to the GRN/WHT terminal.

(To page 6-79)

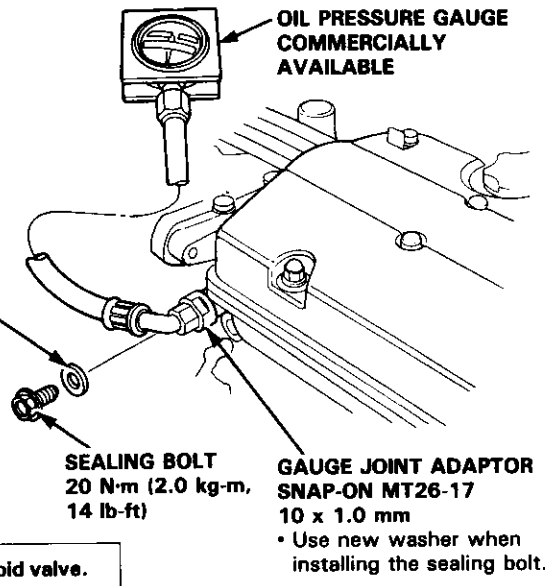
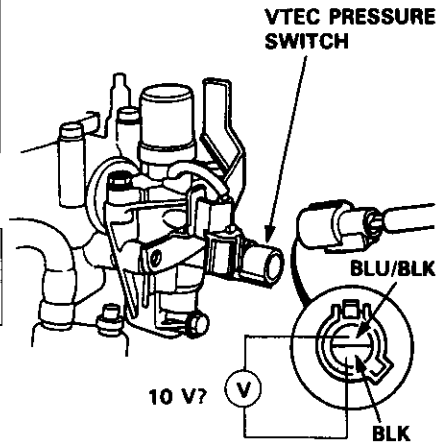

NOTE: Keep measuring time as short as possible because engine is running with no load (less than one minute).



(From page 6-78)

Start the engine and check oil pressure at 5,000 rpm.

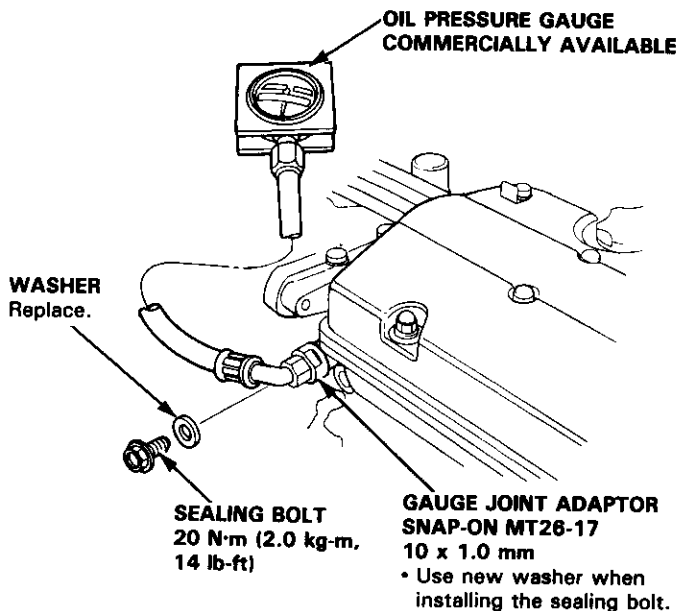

NOTE: Keep measuring time as short as possible because engine is running with no load (less than one minute).

Is pressure above 400 kPa (4 kg/cm², 57 psi)?

NO

Inspect the VTEC solenoid valve.

YES

Turn the ignition switch OFF.

Reconnect the 2P connector to the VTEC pressure switch.

Install the test harness (page 11-25).

Start the engine and run above 5,000 rpm. Measure the voltage between D6 (+) and D22 (-) terminal of the ECM.

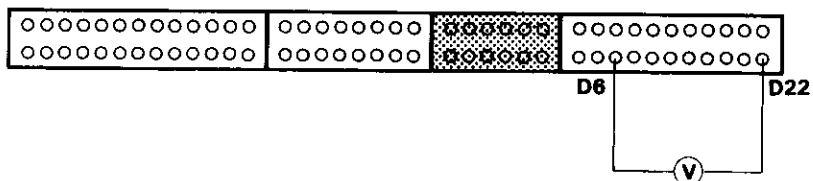

Is there approx. 10 V above 5,000 rpm?

NO

Replace the VTEC pressure switch.

YES

Substitute a known-good ECM and recheck. If symptom/indication goes away replace the original ECM.

VTEC

VTEC Solenoid Valve Inspection

1. Disconnect the 1P connector from the VTEC solenoid valve.
2. Measure resistance between the terminal and body ground.

Resistance: approx 14–30 ohms

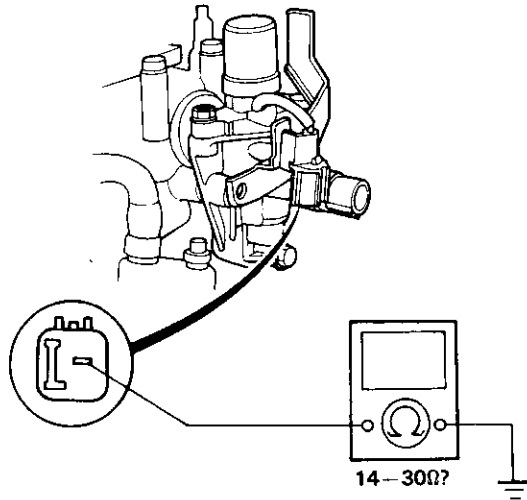

3. If the resistance is within specifications, remove the VTEC solenoid valve from the cylinder head, and check the VTEC solenoid valve filter for clogging.
 - If there is clogging, replace the engine oil filter and the engine oil.

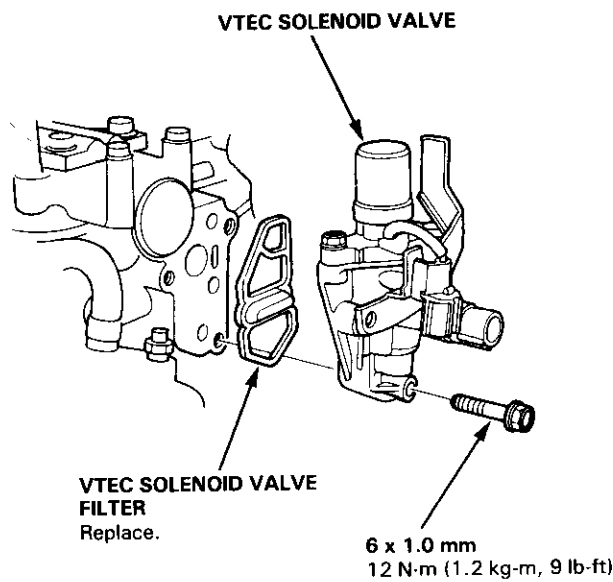

4. If the filter is not clogged, push the VTEC solenoid valve with your finger and check its movement.
 - If VTEC solenoid valve is normal, check the engine oil pressure.

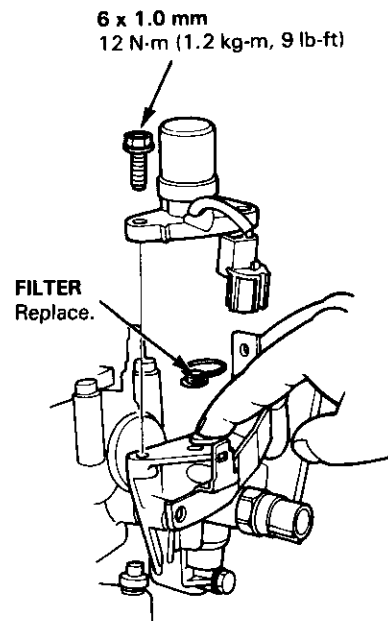



Rocker Arms

Manual Inspection

1. Remove the cylinder head cover.
2. Push the mid rocker arm on the No. 1 cylinder manually.
3. Check that the mid rocker arm moves independently of the primary and secondary intake rocker arms.

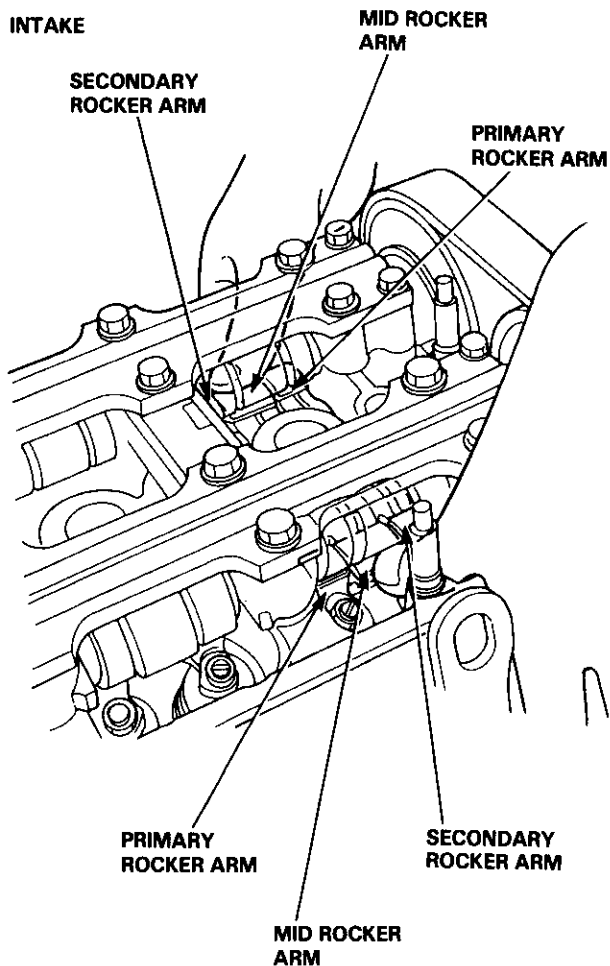

EXHAUST

4. Check the mid rocker arm of each cylinder at TDC.
 - If the mid rocker arm does not move, remove the mid, primary and secondary rocker arms as an assembly and check that the pistons in the mid and primary rocker arms move smoothly.
 - If any rocker arm needs replacing, replace the primary, mid, and secondary rocker arms as an assembly.

Inspection Using Special Tools

CAUTION:

- Before using the special tool (Valve Inspection Tool), make sure that the air pressure gauge on the air compressor indicates over 250 kPa (2.5 kg/cm², 36 psi).
- Inspect the valve clearance before rocker arm inspection.
- Cover the timing belt with a shop towel to protect the belt from oil soaking.
- Check the mid rocker arm of each piston at TDC.

1. Remove the cylinder head cover.
2. Plug the relief hole with the special tool.

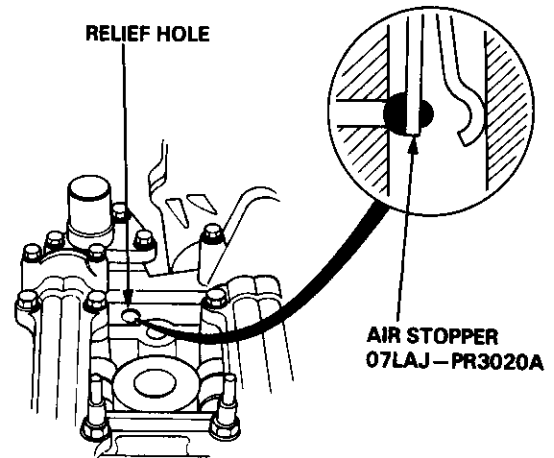

(cont'd)

Rocker Arms

Inspection Using Special Tools (cont'd)

3. Remove the bolt and washer from the inspection hole and connect the valve inspection tool.

REGULATOR VALVE
Pull the lever and turn to adjust.

VALVE INSPECTION TOOL
COMMERCIALY AVAILABLE

AIR STOPPER
07LAJ-PR3020A

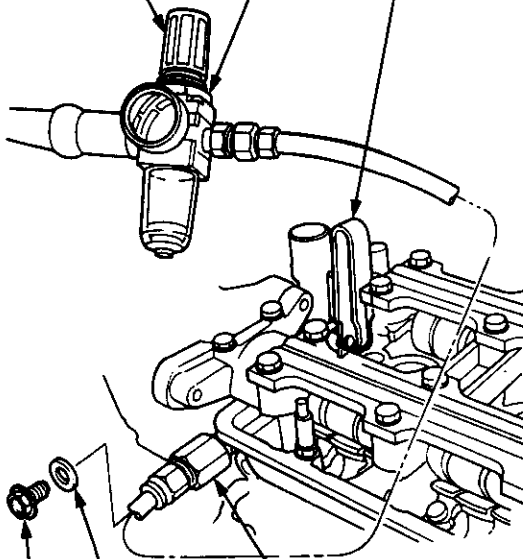

WASHER
Replace.

SEALING BOLT
10 x 1.0 mm
20 N·m (2.0 kg·m,
14 lb·ft)

10 x 1.0 mm
ADAPTER
SNAP-ON MT26-17
or EQUIVALENT

4. Loosen the regulator valve on the valve inspection tool and apply the specified air pressure to the rocker arm pistons.

Specified Air Pressure:
250 kPa (2.5 kg/cm², 36 psi)
— 500 kPa (5.0 kg/cm², 71 psi)

5. Make sure that the intake primary and secondary rocker arms are mechanically connected by the pistons and that the mid rocker arms do not move when pushed manually.

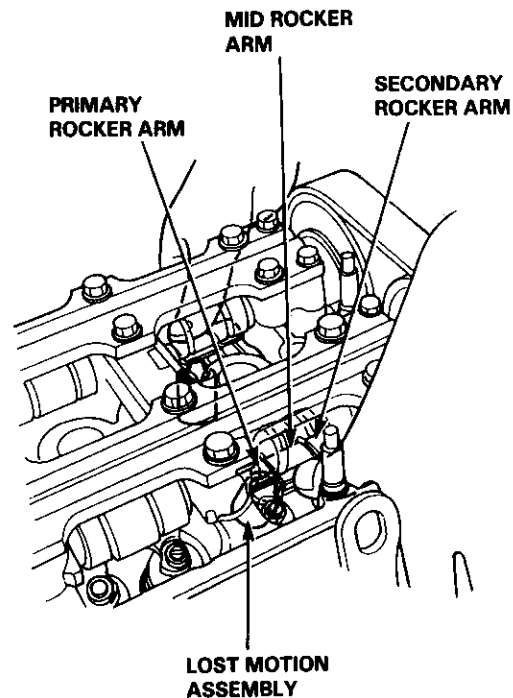

- If any mid rocker arm independently of the primary and secondary rocker arms, replace the rocker arms, as a set.

6. Remove the tools.
7. Check for smooth operation of the lost motion assembly. It is compressed slightly when the mid rocker arm is lightly pushed and compressed deeply when the mid rocker arm is strongly pushed.
 - Replace the lost motion assembly if it does not move smoothly.
8. After inspection, check that the malfunction indicator lamp (MIL) does not come on.

Cylinder Head

Removal

Engine removal is not required for this procedure.

▲ WARNING

- Make sure jacks and safety stands are placed properly and hoist brackets are attached to correct positions on the engine.
- Make sure the car will not roll off stands and fall while you are working under it.

CAUTION:

- Use fender covers to avoid damaging painted surfaces.
- Unplug the wiring connectors carefully while holding the connector portion to avoid damage.
- Mark all wiring and hoses to avoid misconnection. Also, be sure that they do not contact other wiring or hoses or interfere with other parts.
- To avoid damaging the cylinder head, wait until the coolant temperature drops below 100°F (38°C) engine before loosening the retaining bolts.

NOTE:

- Inspect the timing belt before removing the cylinder head.
- Turn the crankshaft pulley so that the No. 1 piston is at top dead center (page 6-106).
- Mark all emission hoses before disconnecting them.

NOTE: The radio may have a coded theft protection circuit. Be sure to get the customer's code number before

- Disconnecting the battery.
- Removing the No. 43 (10 A) fuse (In the under-hood fuse/relay box).
- Removing the radio.

After service, reconnect power to the radio and turn it on.

When the word "CODE" is displayed, enter the customer's 5-digit code to restore radio operation.

1. Disconnect the negative terminal from the battery.
2. Drain the engine coolant (see section 10).
 - Remove the radiator cap to speed draining

3. Relieve fuel pressure.

▲ WARNING

Do not smoke while working on fuel system, keep open flame or spark away from work area. Drain fuel only into an approved container.

4. Remove the intake air duct.
5. Remove the fuel feed hose and evaporative emission (EVAP) control canister hose from the intake manifold.

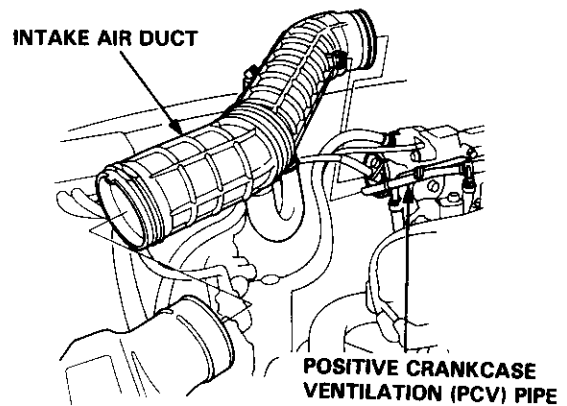

6. Remove the throttle cable from the throttle body.

NOTE:

- Take care not to bend the cable when removing it. Always replace any kinked cable with a new one.
- Adjust the throttle cable when installing (see section 11).

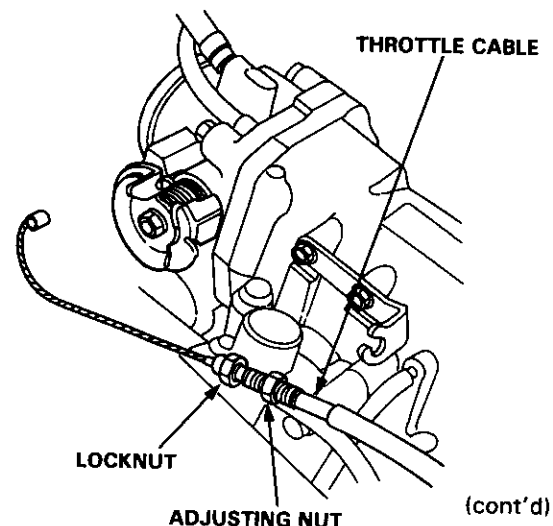

(cont'd)

Cylinder Head

Removal (cont'd)

7. Remove the fuel feed hose, the fuel return hose and the brake booster vacuum hose.

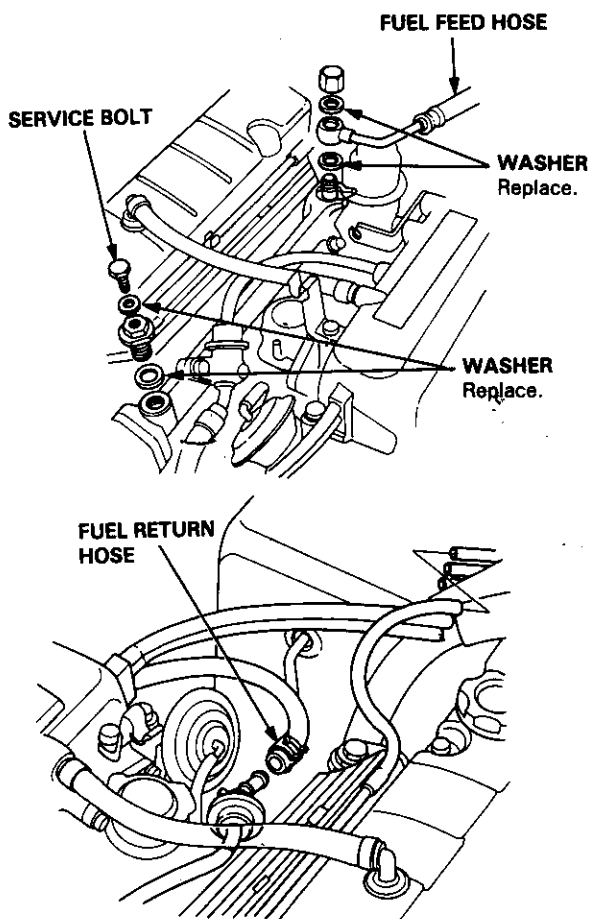

8. Remove the following engine wire harness connectors and clamps from the cylinder head and the intake manifold:

- Four fuel injector connectors
- Intake air temperature (IAT) sensor connector
- Idle air control (IAC) valve connector
- Throttle position (TP) sensor connector
- Exhaust gas recirculation (EGR) valve lift sensor connector
- Ground cable terminals
- Engine coolant temperature (ECT) switch B connector
- Heated oxygen sensor (HO2S) connector
- ECT sensor connector
- ECT gauge sending unit connector
- Ignition control module (ICM) connector
- CKP/TDC/CYP sensor connector
- Vehicle speed sensor (VSS) connector
- Ignition coil connector
- VTEC solenoid valve connector
- VTEC presser switch connector
- Intake air bypass solenoid valve connector
- ECT switch A connector
- Knock sensor connector

9. Remove the engine ground cable from the cylinder head cover.

10. Disconnect the alternator terminal and connector, then remove the engine wire harness from the cylinder head cover.

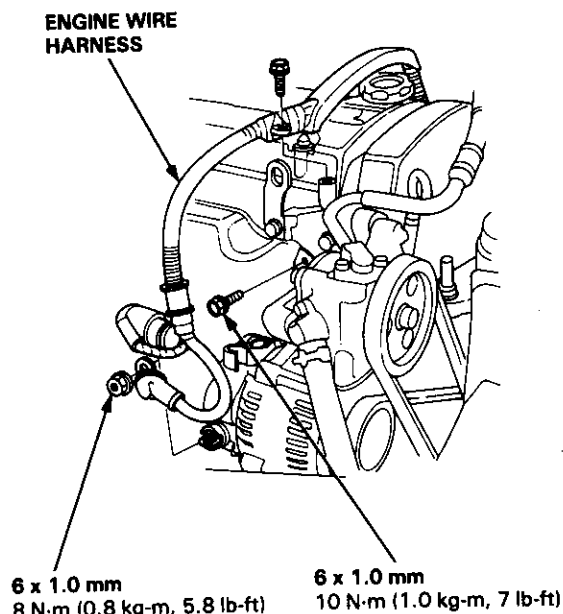

11. Remove the power steering (P/S) pump belt and pump.
- Do not disconnect the P/S hoses.

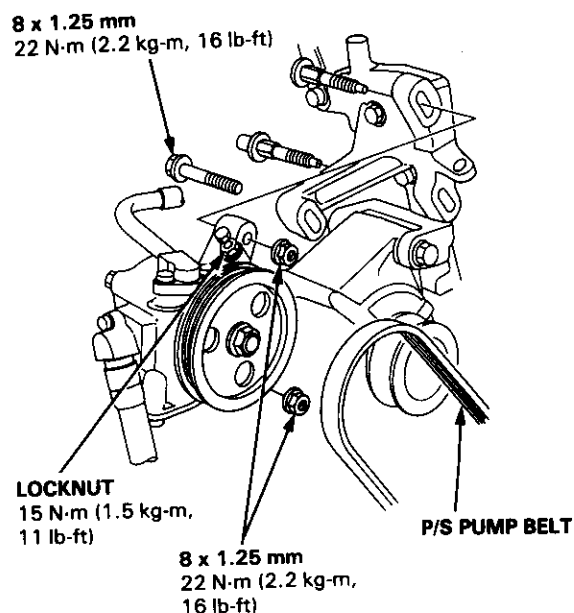



12. Remove the ignition coil.

☆: CORROSION RESISTANT BOLT

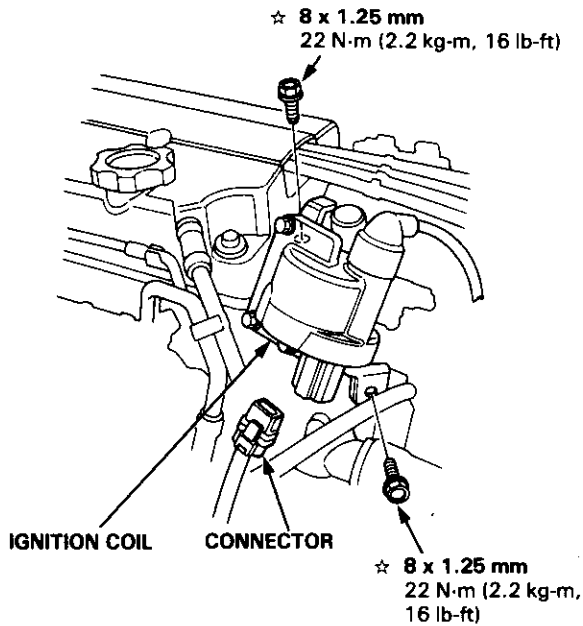

13. Remove the emission vacuum hoses and water bypass hoses from the intake manifold assembly.

14. Remove the radiator upper hose and heater hose from the cylinder head.

15. Remove the water bypass hose and the thermostat housing.

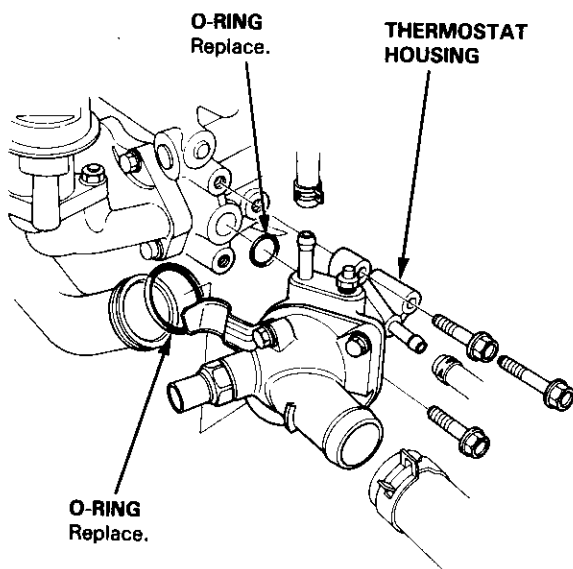

16. Remove the bracket and intake manifold.

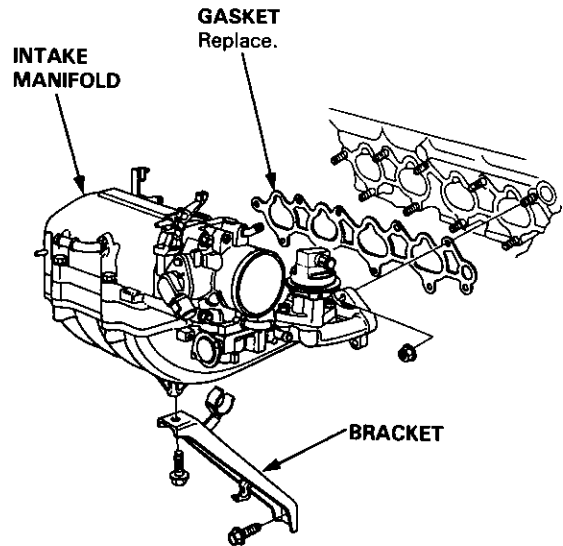

17. Remove the self-locking nuts and disconnect the exhaust manifold and exhaust pipe A.

18. Remove the heat insulator, brackets and exhaust manifold.

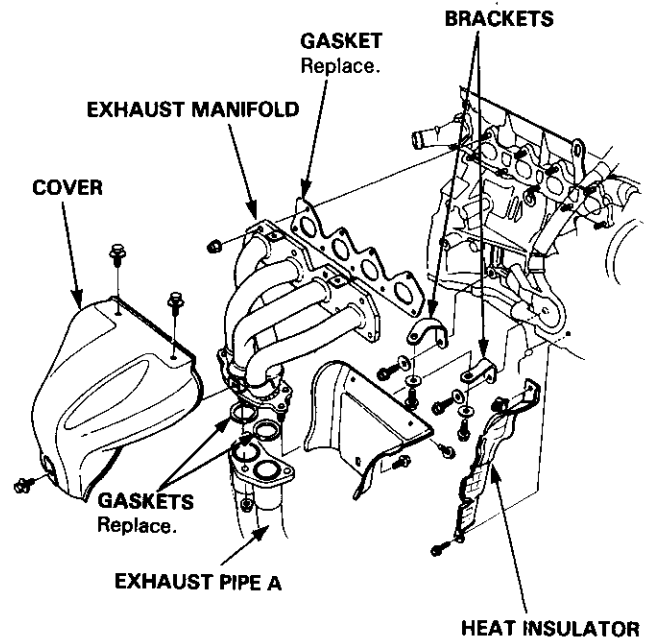

(cont'd)

Cylinder Head

Removal (cont'd)

19. Remove the cylinder head cover.
20. Remove the middle cover.
21. Use a wrench to loosen the maintenance bolt. If it cannot be loosened with an open-end wrench, a box wrench can be used after pulling out the lock pin.

NOTE: Use of a tool should be limited to initial loosening only.

22. Loosen the maintenance bolt by hand until it stops. The auto-tensioner bracket is now fixed.

NOTE:

- Never use a tool to loosen the maintenance bolt after initial loosening.
- If the auto-tensioner has been extended and the timing belt cannot be installed, remove the auto-tensioner, compress it and reinstall it (page 6-112).

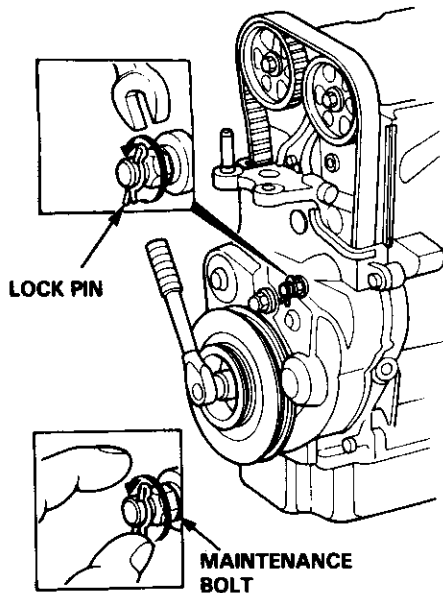

Auto-tensioner functional.

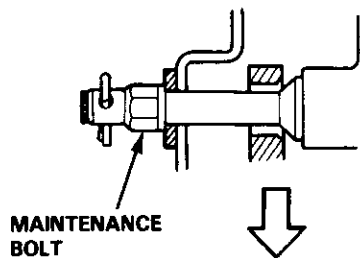

Auto-tensioner fixed in place.

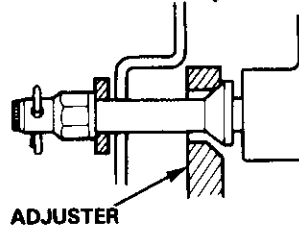

23. Remove the belt from the camshaft pulleys.

CAUTION: Do not crimp or bend the timing belt more than 90° or less than 25 mm (1 in) in diameter.

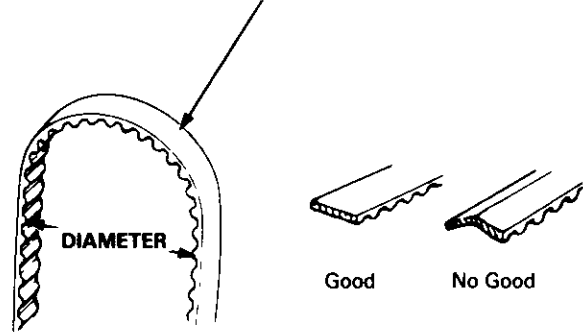

24. Remove the camshaft pulleys.

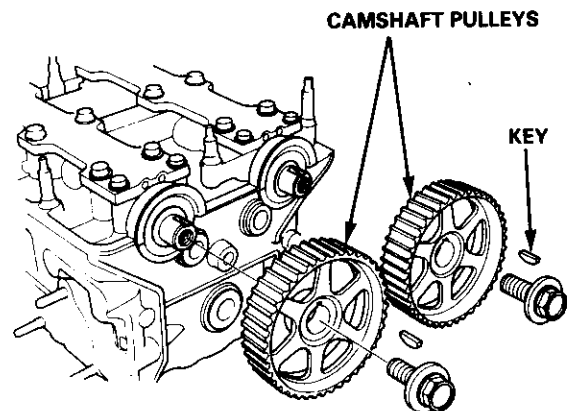



25. Loosen the rocker arm adjusting screws, then remove the camshaft holders and camshafts.

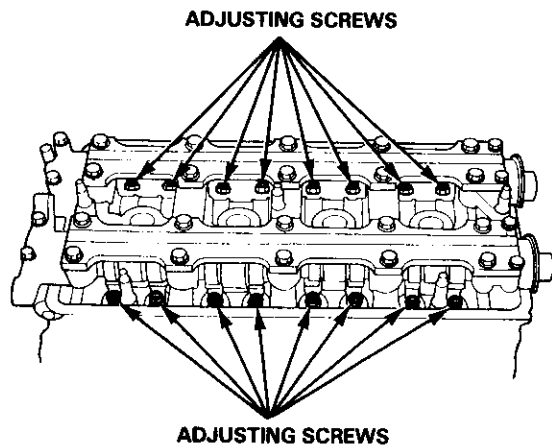

26. Remove the side engine mount bracket B and timing belt back cover.

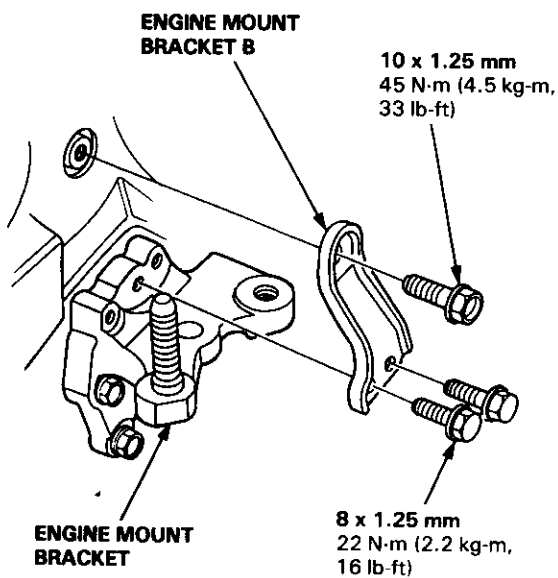

27. Remove the cylinder head bolts, then remove the cylinder head.

CAUTION: To prevent warpage, unscrew the bolts in sequence 1/3 turn at a time; repeat the sequence until all bolts are loosened.

CYLINDER HEAD BOLT LOOSENING SEQUENCE

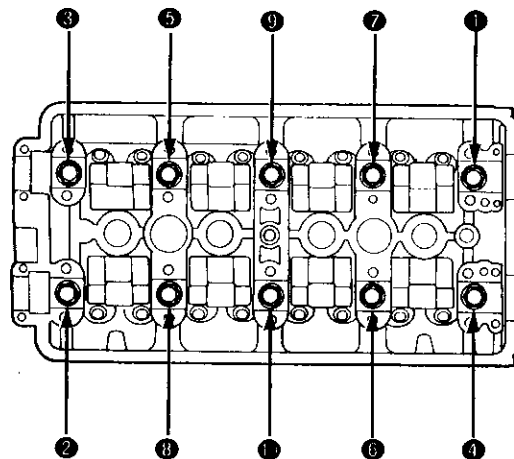

NOTE: Separate the cylinder head from the block with a flat tip screwdriver as shown.

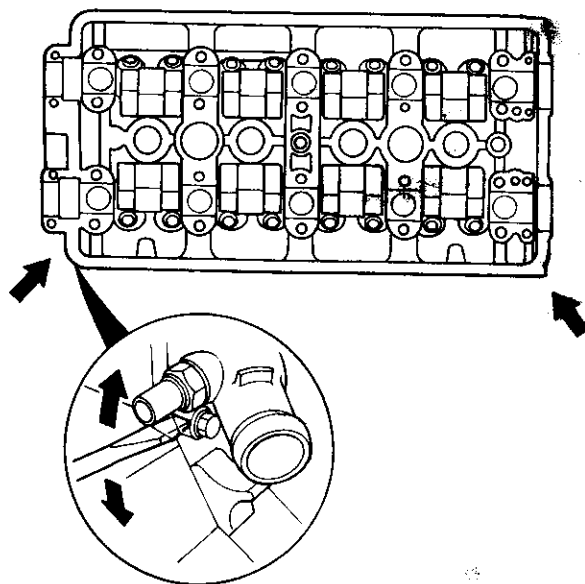

Rocker Arms and Shafts

Removal

1. Loosen the adjusting screws, then remove the bolts and the rocker arm assembly.

NOTE:

- Unscrew the camshaft holder bolts two turns at a time, in a crisscross pattern, to prevent damaging the valves or rocker arm assembly.
- When removing the rocker arm assembly, do not remove the camshaft holder bolts. The bolts will keep the camshaft holders, the springs and the rocker arms on the shafts.

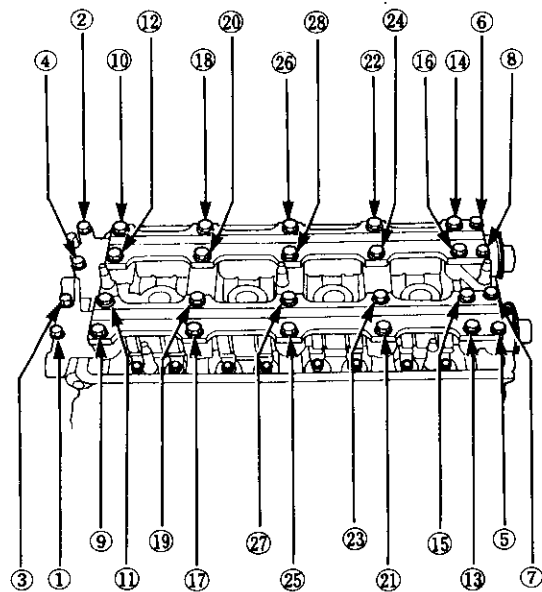
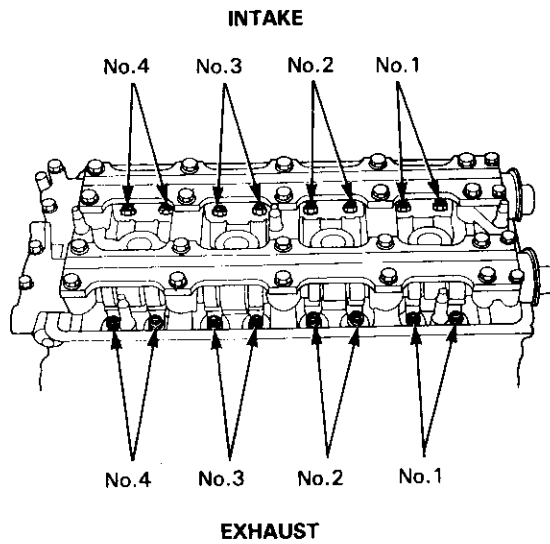

2. Remove the VTEC solenoid valve and filter.

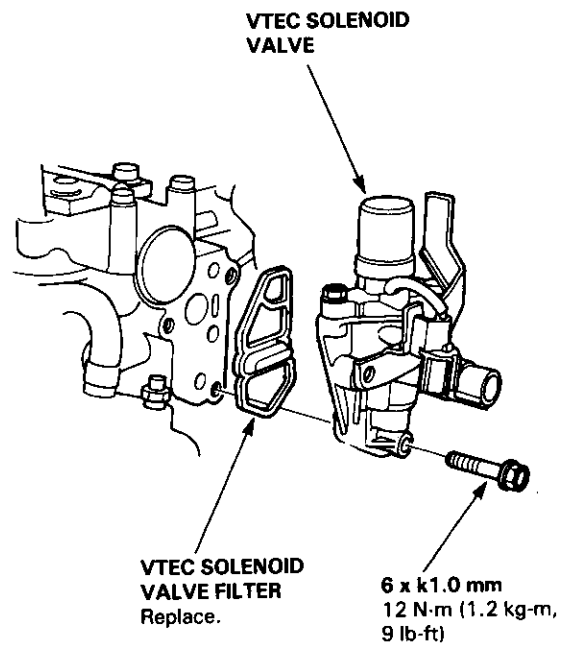



3. Hold the rocker arms together with a rubber band to prevent them from separating.

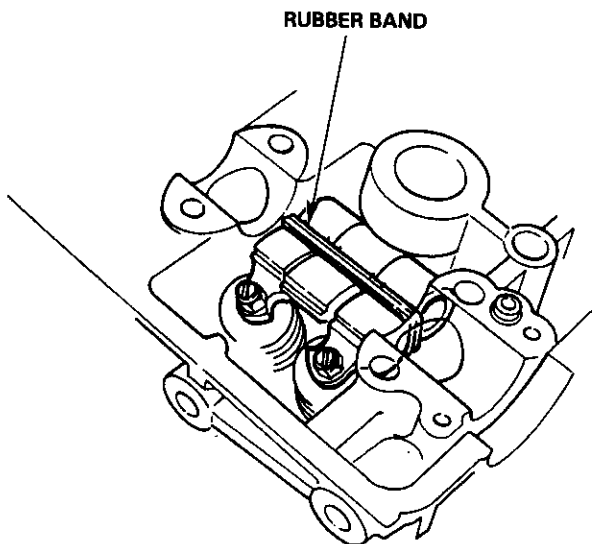

4. Remove the intake and exhaust rocker shaft orifice.

NOTE: The shapes of the rocker shaft orifices of the intake and exhaust are different. Identify the parts as they are removed to ensure reinstallation in the original locations.

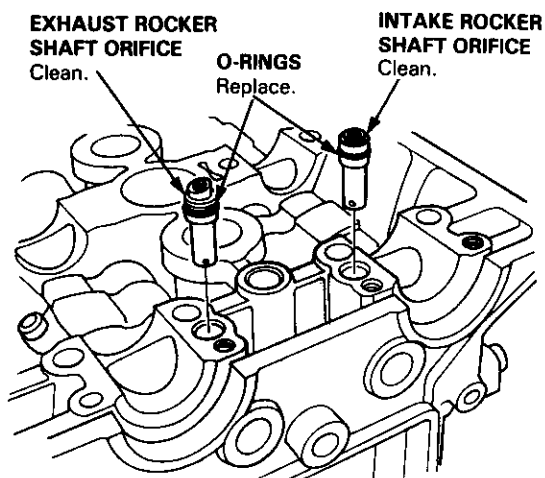

5. Screw 12 mm bolts into the rocker arm shafts. Remove each rocker arm while slowly pulling out the intake and exhaust rocker arm shafts.

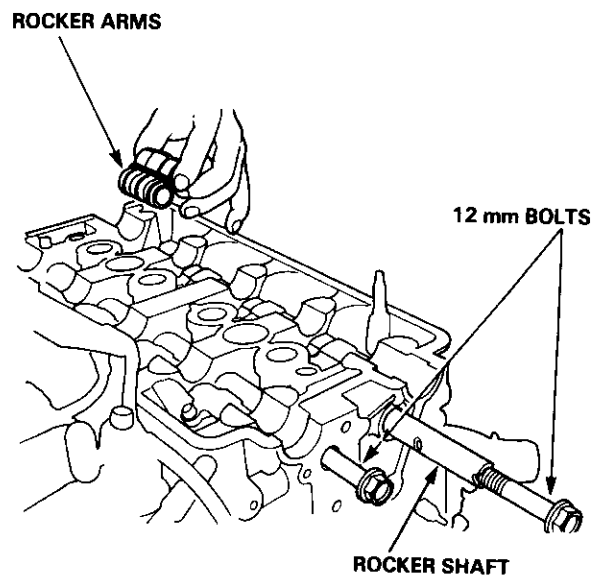

Rocker Arms and Shafts

Locations

CAUTION: After installing the rocker shaft orifice, try to turn the rocker shaft to make sure that the orifice has been inserted in the hole of rocker shaft correctly. If the orifice is in place, it should not turn.

NOTE:

- Identify parts as they are removed to ensure reinstallation in original locations.
- Inspect rocker shafts and rocker arms (pages 6-93 and 94).
- Rocker arms must be installed in the same position if reused.
- Clean the intake and exhaust rocker shaft orifices before installing.



Prior to reinstalling, clean all the parts in solvent, dry them and apply lubricant to any contact surfaces.

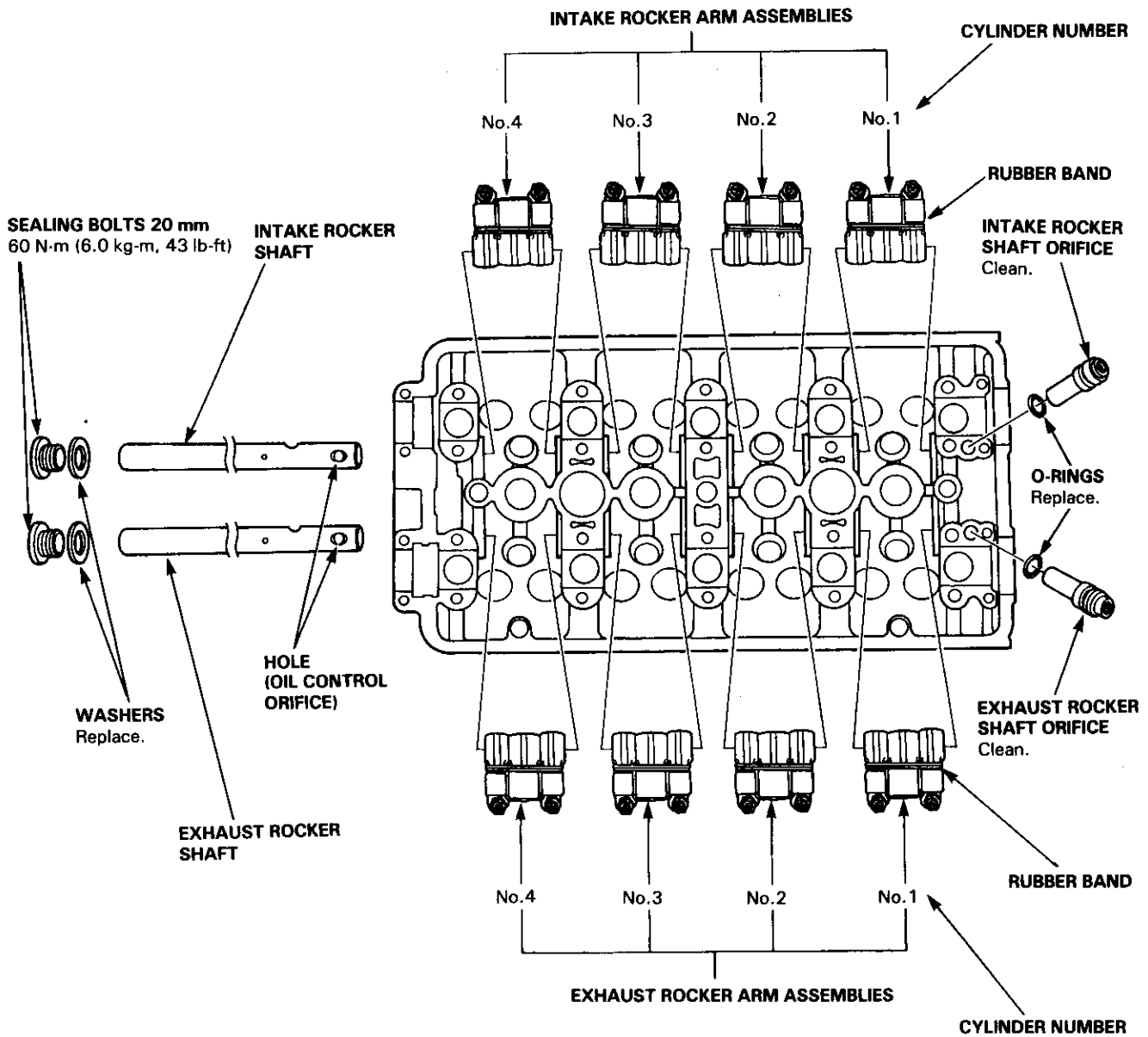

Rocker Arms and Shafts



Clearance

Measure both the intake rocker shaft and exhaust rocker shaft.

1. Measure diameter of shaft at first rocker location.

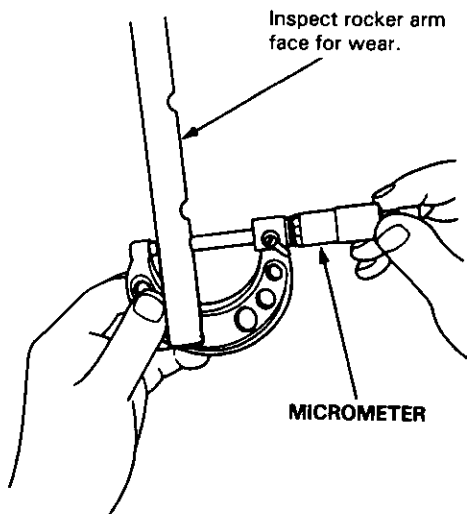

2. Zero gauge to shaft diameter.

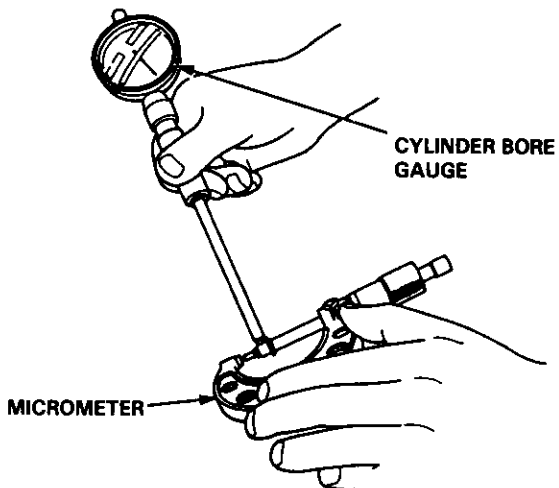

3. Measure inside diameter of rocker arm and check for out-of-round condition.

Rocker Arm-to-Shaft Clearance:

Intake and Exhaust

Standard (New): 0.025–0.052 mm
(0.0010–0.0020 in.)

Service Limit: 0.08 mm (0.003 in.)

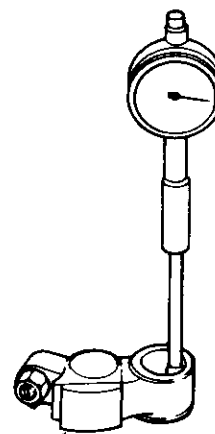

Surface should be smooth.

Repeat for all rockers.

— If over limit, replace rocker shaft and all over-tolerance rocker arms.

NOTE: If any rocker arm needs replacement, replace all three rocker arms in that set (primary, mid, and secondary).

Rocker Arms

Inspection

NOTE: When reassembling the primary rocker arm, carefully apply air pressure to the oil passage of the rocker arm.

1. Inspect the rocker arm piston. Push it manually.
 - If it does not move smoothly, replace the rocker arm assembly.

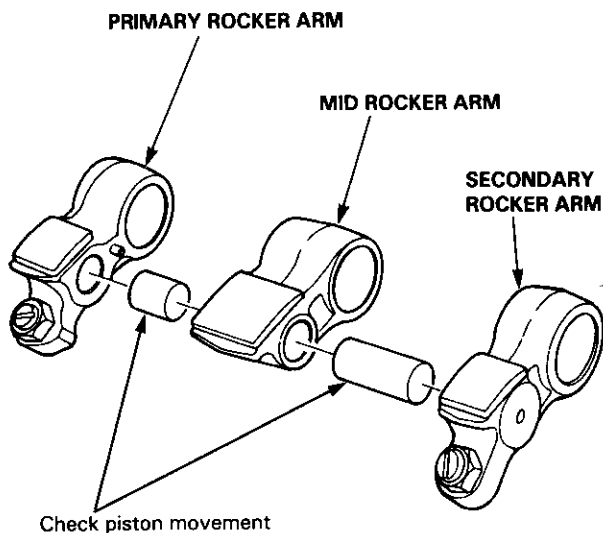

NOTE:

- Apply oil to the pistons when reassembling.
- Bundle the rocker arms with a rubber band to prevent them from separating.

Lost Motion Assemblies

Inspection

1. Remove the lost motion assembly from the cylinder head and inspect it. Pushing it gently with the finger will cause it to sink slightly. Increasing the force on it will cause it to sink deeper.
 - If the lost motion assembly does not move smoothly, replace it.

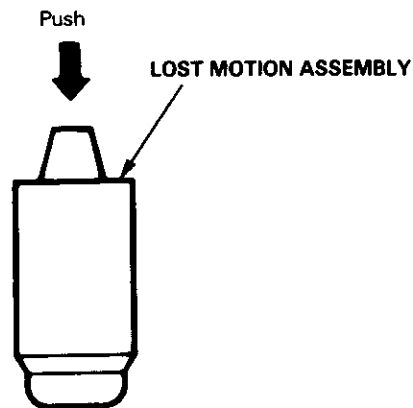

Camshafts

Inspection

NOTE: Do not rotate camshaft during inspection.

1. Remove the rocker arms and rocker shafts.

NOTE: Rocker arms must be installed in the same position if reused.

2. Put the camshafts, camshaft holders and holder pipes on the cylinder head, then tighten the bolts to the specified torque.

Specified torque:

- ①—⑳: 8 x 1.25 mm
26 N·m (2.6 kg·m, 19 lb-ft)
- ㉑—㉘: 6 x 1.0 mm
12 N·m (1.2 kg·m, 9 lb-ft)

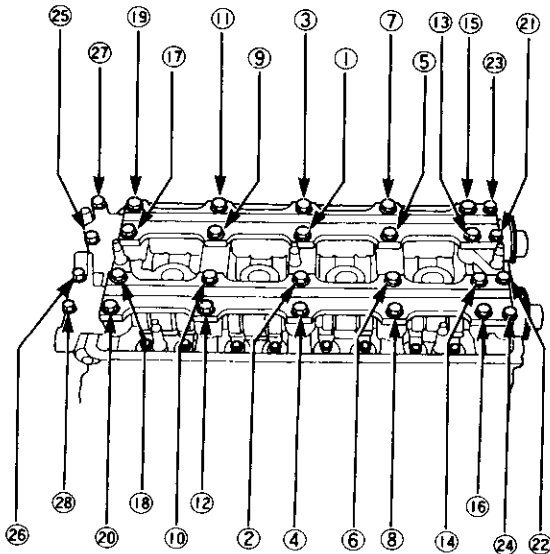

3. Seat camshafts by pushing them toward distributor end of cylinder head.
4. Zero dial indicator against end of camshaft, then push camshaft back and forth and read the end play.

Camshaft End Play:

Standard (New): 0.05—0.15 mm
(0.002—0.006 in)

Service Limit: 0.5 mm (0.02 in)

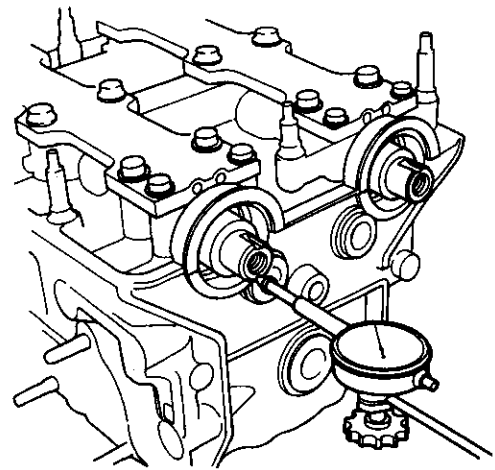

5. Remove the camshaft holders and holder pipes bolts from the cylinder head.
 - Lift camshaft out of cylinder head, wipe clean, then inspect lift ramps. Replace camshaft if lobes are pitted, scored, or excessively worn.
 - Clean the camshaft holder surfaces in the cylinder head, then set camshaft back in place.
 - Insert plastigage strip across each journal.
 - Install the camshaft holders and holder pipes and torque bolts to the values and in the sequence shown in left column.

(cont'd)

Camshafts

Inspection (cont'd)

6. Measure widest portion of plastigage on each journal.

Camshaft-to-Holder Oil Clearance:
Standard (New): 0.050–0.089 mm
 (0.0020–0.0035 in)
Service Limit: 0.15 mm (0.006 in)

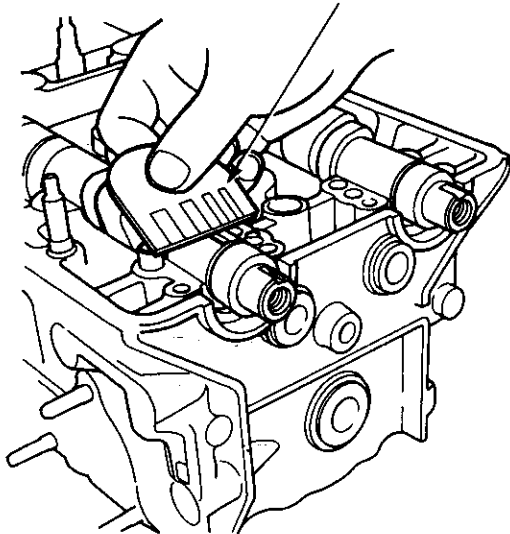

7. If camshaft-to-holder oil clearance is out of tolerance:
- And the camshaft has already been replaced, you must replace the cylinder head.
 - If camshaft has not been replaced, first check total runout with the camshaft supported on V-blocks.

Camshaft Total Runout:
Standard (New): 0.03 mm (0.001 in) max.
Service Limit: 0.06 mm (0.002 in)

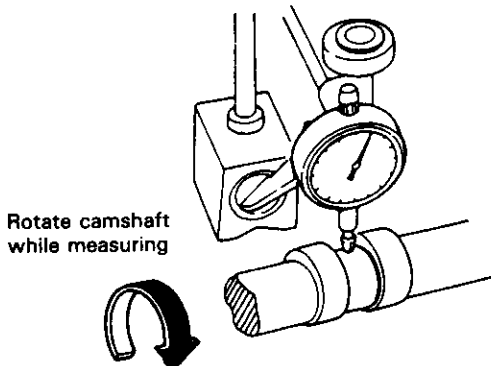

- If the total runout of the camshaft is within tolerance, replace the cylinder head.
- If the total runout is out of tolerance, replace the camshaft and recheck. If the bearing clearance is still out of tolerance, replace the cylinder head.

Measure cam lobe height.

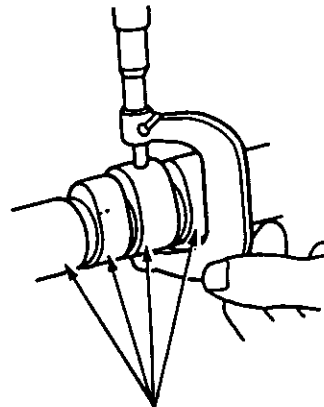

Inspect this area for wear.

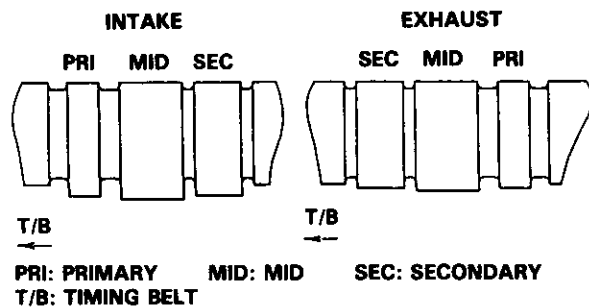

Cam Lobe Height Standard (New):

	INTAKE	EXHAUST
PRIMARY	34.041 mm (1.3402 in)	33.745 mm (1.3285 in)
MID	36.856 mm (1.4510 in)	36.323 mm (1.4300 in)
SECONDARY	34.971 mm (1.3768 in)	34.683 mm (1.3655 in)



Valves, Valve Springs and Valve Seals

Removal

NOTE: Identify valves and valve springs as they are removed so that each item can be reinstalled in its original position.

1. Using an appropriately-sized socket and plastic mallet, lightly tap the valve retainer to loosen the valve keepers before installing the valve spring compressor.

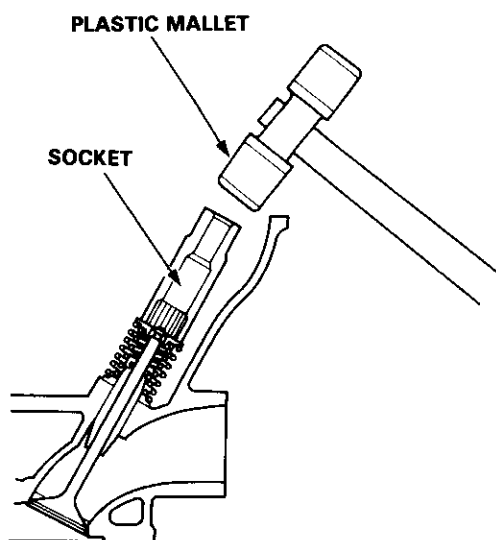

2. Install spring compressor. Compress spring and remove valve keeper.

**VALVE SPRING
COMPRESSOR ATTACHMENT
EXTENSION
07MAF-PR9010A**

**VALVE SPRING
COMPRESSOR
ATTACHMENT
07757-PJ1010A**

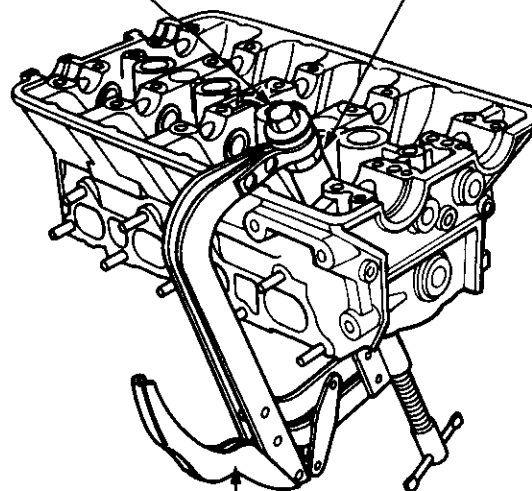

**VALVE SPRING COMPRESSOR
SNAP-ON CF711**

(cont'd)

Valves, Valve Springs and Valve Seals

Removal (cont'd)

3. Install the special tool as shown.

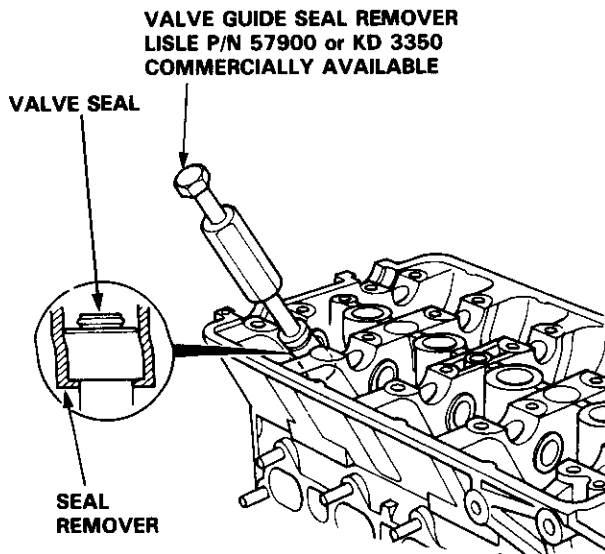

4. Remove the valve seal.

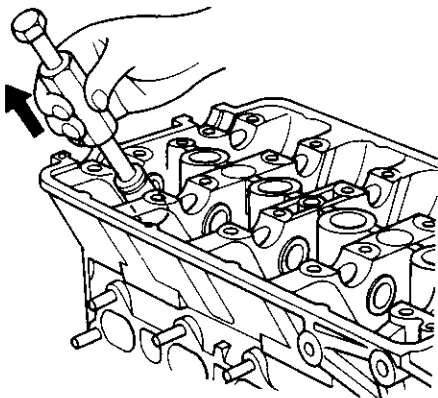

Valve Dimensions:

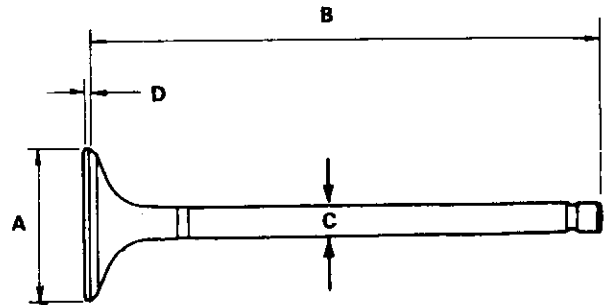

Intake Valve

- A Standard (New):** 34.90–35.10 mm
(1.374–1.382 in)
- B Standard (New):** 105.40–105.70 mm
(4.150–4.161 in)
- C Standard (New):** 5.475–5.483 mm
(0.2156–0.2159 in)
- C Service Limit:** 5.445 (0.2144 in)
- D Standard (New):** 1.05–1.35 mm
(0.041–0.053 in)
- D Service Limit:** 0.85 mm (0.034 in)

Exhaust Valve

- A Standard (New):** 29.90–30.10 mm
(1.177–1.185 in)
- B Standard (New):** 105.00–105.30 mm
(4.134–4.146 in)
- C Standard (New):** 5.475–5.485 mm
(0.2156–0.2159 in)
- C Service Limit:** 5.445 (0.2144 in)
- D Standard (New):** 1.65–1.95 mm
(0.065–0.078 in)
- D Service Limit:** 1.45 mm (0.057 in)



Valve Seats

Reconditioning

1. Renew the valve seats in the cylinder head using a valve seat cutter.

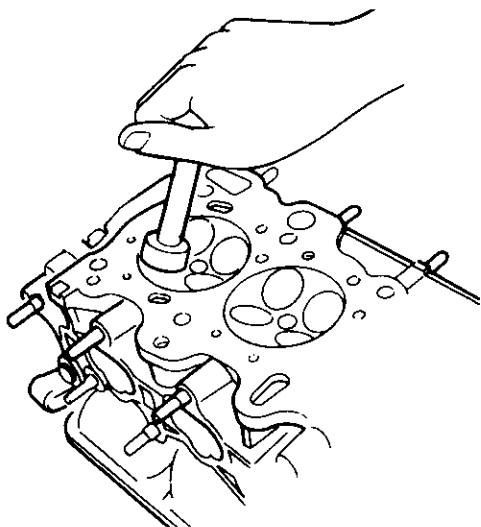

NOTE: If guides are worn (page 6-98), replace them (page 6-99) before cutting the valve seats.

2. Carefully cut a 45° seat, removing only enough material to ensure a smooth and concentric seat.
3. Bevel the upper edge of the seat with the 30° cutter and the lower edge of the seat with the 60° cutter. Check width of seat and adjust accordingly.
4. Make one more very light pass with the 45° cutter to remove any possible burrs caused by the other cutters.

Valve Seat Width (Intake and exhaust):
Standard (New): 1.25–1.55 mm
 (0.049–0.061 in)
Service Limit: 2.00 mm (0.079 in)

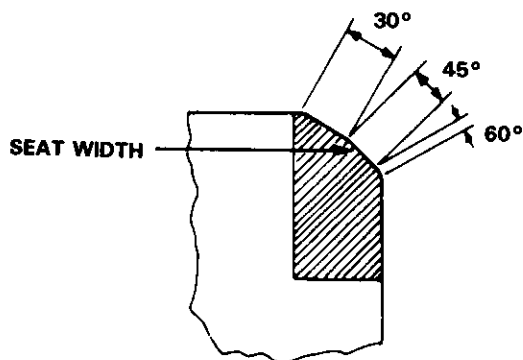

5. After resurfacing the seat, inspect for even valve seating: Apply Prussian Blue compound to the valve face, and insert valve in original location in the head, then lift it and snap it closed against the seat several times.

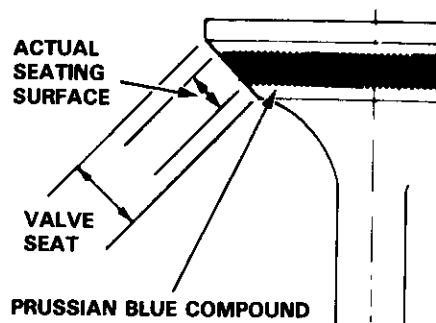

6. The actual valve seating surface, as shown by the blue compound, should be centered on the seat.
 - If it is too high (closer to the valve stem), you must make a second cut with the 60° cutter to move it down, then one more cut with the 45° cutter to restore seat width.
 - If it is too low (close to the valve edge), you must make a second cut with the 30° cutter to move it up, then one more cut with the 45° cutter to restore seat width.

NOTE: The final cut should always be made with the 45° cutter.

7. Insert intake and exhaust valves in the head and measure valve stem installed height.

Intake Valve Stem Installed Height:

Standard (New): 37.465–37.935 mm
 (1.4750–1.4935 in)

Service Limit: 38.185 mm (1.5033 in)

Exhaust Valve Stem Installed Height:

Standard (New): 37.165–37.635 mm
 (1.4632–1.4817 in)

Service Limit: 37.885 mm (1.4915 in)

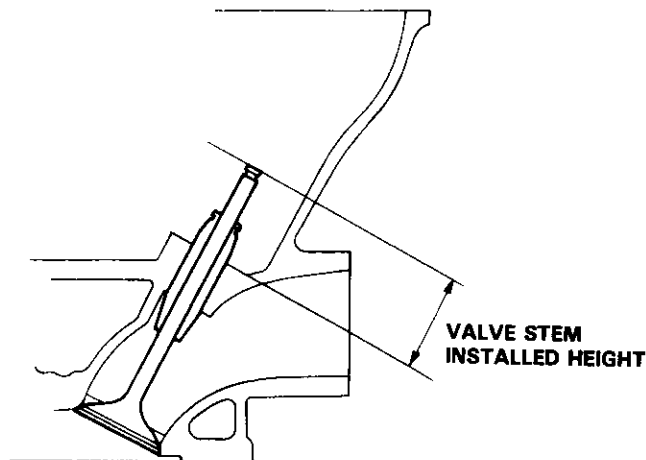

8. If valve stem installed height is over the service limit, replace valve and recheck. If still over the service limit, replace cylinder head; the valve seat in the head is too deep.

Cylinder Head

Warpage

NOTE: If camshaft-to-holder oil clearances (page 6-93) are not within specification, the head cannot be resurfaced.

If camshaft-to-holder oil clearances are within specifications, check the head for warpage.

- If warpage is less than 0.05 mm (0.002 in) cylinder head resurfacing is not required.
- If warpage is between 0.05 mm (0.002 in) and 0.2 mm (0.008 in), resurface cylinder head.
- Maximum resurface limit is 0.2 mm (0.008 in) based on a height of 132.0 mm (5.20 in).

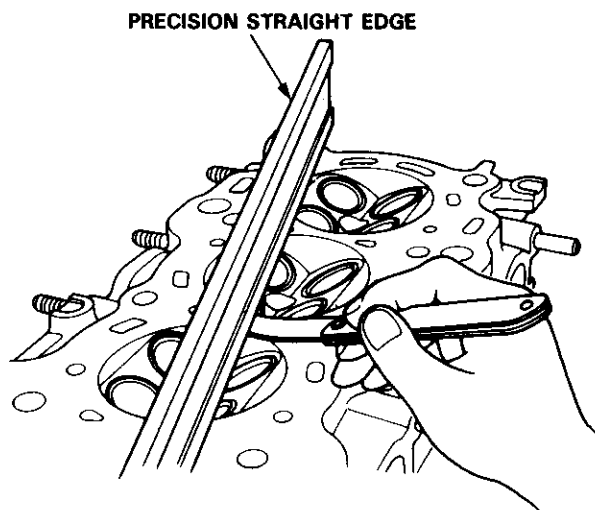

Measure along edges, and 3 ways across center.

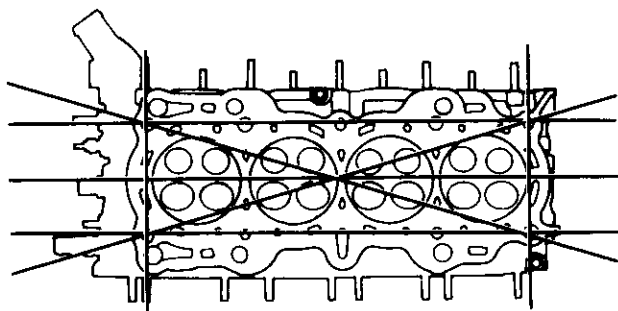

Cylinder Head Height:
Standard (New): 141.95–142.05 mm
(5.589–5.593 in)

Valve Guides

Valve Movement

Measure the guide-to-stem clearance with a dial indicator while rocking the stem in the direction of normal thrust (wobble method).

Intake Valve Stem-to-Guide Clearance:

Standard (New): 0.05–0.11 mm
(0.002–0.004 in)

Service Limit: 0.16 mm (0.006 in)

Exhaust Valve Stem-to-Guide Clearance:

Standard (New): 0.10–0.16 mm
(0.004–0.006 in)

Service Limit: 0.22 mm (0.009 in)

Valve extended 10 mm out from seat.

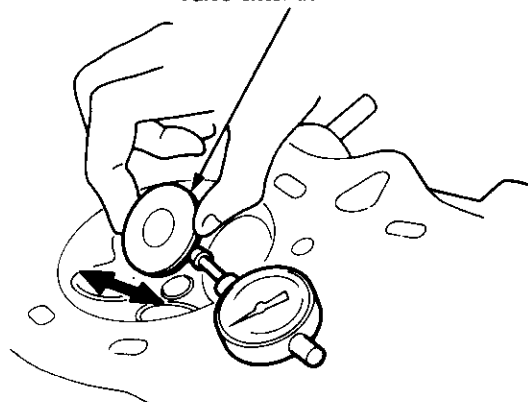

- If measurement exceeds the service limit, recheck using a new valve.
- If measurement is now within the service limit, reassemble using a new valve.
- If measurement still exceeds limit, recheck using alternate method below, then replace valve and guide, if necessary.

NOTE: An alternate method of checking guide to stem clearance is to subtract the O.D. of the valve stem, measured with a micrometer, from the I.D. of the valve guide, measured with an inside micrometer or ball gauge.

Take the measurements in three places along the valve stem and three places inside the valve guide. The difference between the largest guide measurement and the smallest stem measurement should not exceed the service limit.

Intake Valve Stem-to-Guide Clearance:

Standard (New): 0.025–0.055 mm
(0.0010–0.0022 in)

Service Limit: 0.08 mm (0.003 in)

Exhaust Valve Stem-to-Guide Clearance:

Standard (New): 0.050–0.080 mm
(0.0020–0.0031 in)

Service Limit: 0.11 mm (0.004 in)



Replacement

1. As illustrated in the removal steps of this procedure, use a commercially-available air-impact driver attachment modified to fit the diameter of the valve guides. In most cases, the same procedure can be done using Valve Guide Drivers and a conventional hammer. Tool numbers are at the end of this procedure.

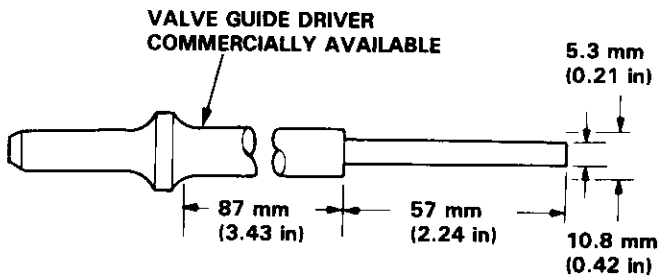

Removal and Installation
VALVE GUIDE DRIVER, 5.5 mm
 07742-0010100

2. Select the proper replacement guides and chill them in the freezer section of a refrigerator for about an hour.
3. Use a hot plate or oven to evenly heat the cylinder head to 300°F (150°C). Monitor the temperature with a cooking thermometer.

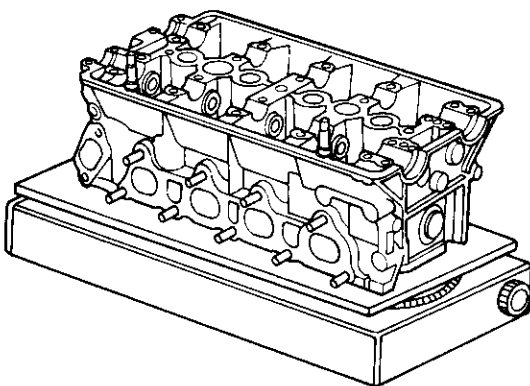

CAUTION:

- Do not use a torch; it may warp the head.
- Do not get the head hotter than 300°F (150°C); excessive heat may loosen the valve seats.
- To avoid burns, use heavy gloves when handling the heated cylinder head.

4. Working from the camshaft side, use the driver and an air hammer to driver the guide about 2 mm (0.1 in) towards the combustion chamber. This will knock off some of the carbon and make removal easier.

CAUTION:

- Always wear safety goggles or a face shield when using the air hammer.
- Hold the air hammer directly in line with the valve guide to prevent damaging the driver.

5. Turn the head over and drive the guide out toward the camshaft side of head.

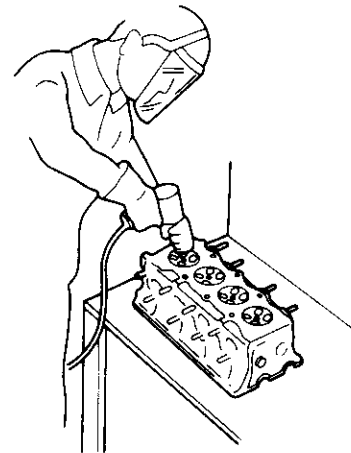

VALVE GUIDE DRIVER,
 COMMERCIALY AVAILABLE

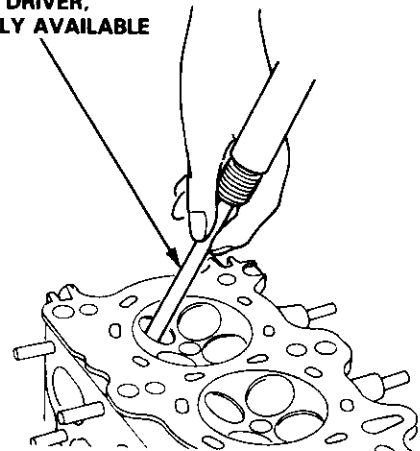

If a valve guide still won't move, drill it out with a 8 mm (5/16 inch) bit, then try again.

CAUTION: Drill guides only in extreme cases; you could damage the cylinder head if the guide breaks.

6. Remove the new guide(s) from the refrigerator, one at a time, as you need them.

(cont'd)

Valve Guides

Replacement (cont'd)

- Slip a 6 mm (0.2 in) steel washer and the correct driver attachment over the end of the driver (the washer will absorb some of the impact and extend the life of the driver).

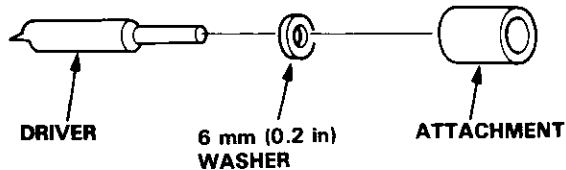

- Install the new guide(s) from the camshaft side of the head; drive each one in until the attachment bottoms on the head. If you have all sixteen guides to do, you may have to reheat the head one or two more times.

VALVE GUIDE DRIVER,
5.5 mm
07742-0010100

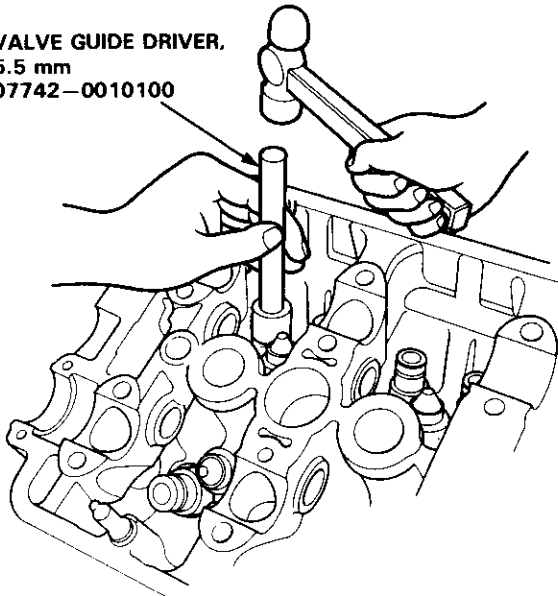

Valve Guide Installed Height:

Standard (New):

Intake: 12.55–13.05 mm (0.494–0.514 in)

Exhaust: 12.55–13.05 mm (0.494–0.514 in)

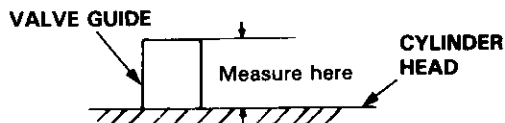

Reaming

NOTE: For new valve guides only.

- Coat both reamer and valve guide with cutting oil.
- Rotate the reamer clockwise the full length of the valve guide bore.
- Continue to rotate the reamer clockwise while removing it from the bore.
- Thoroughly wash the guide in detergent and water to remove any cutting residue.
- Check clearance with a valve (page 6-98).
 - Verify that the valve slides in the intake and exhaust valve guides without exerting pressure.

REAMER HANDLE

Turn reamer in
clockwise direction
only.

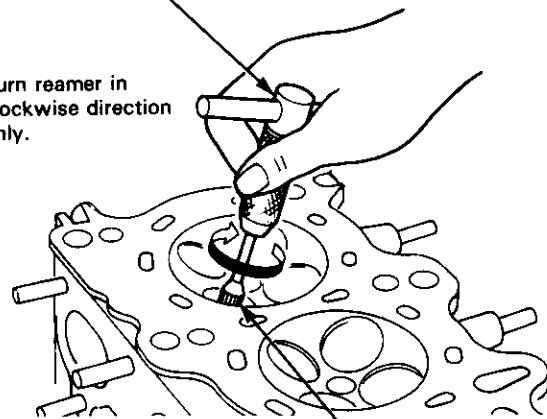

VALVE GUIDE REAMER,
5.5 mm
07HAH-PJ7010A
07HAH-PJ7010B



Valves, Valve Springs and Valve Seals

Valve Spring and Valve Seal Installation Sequence

NOTE: Exhaust and intake valve seals are NOT interchangeable.

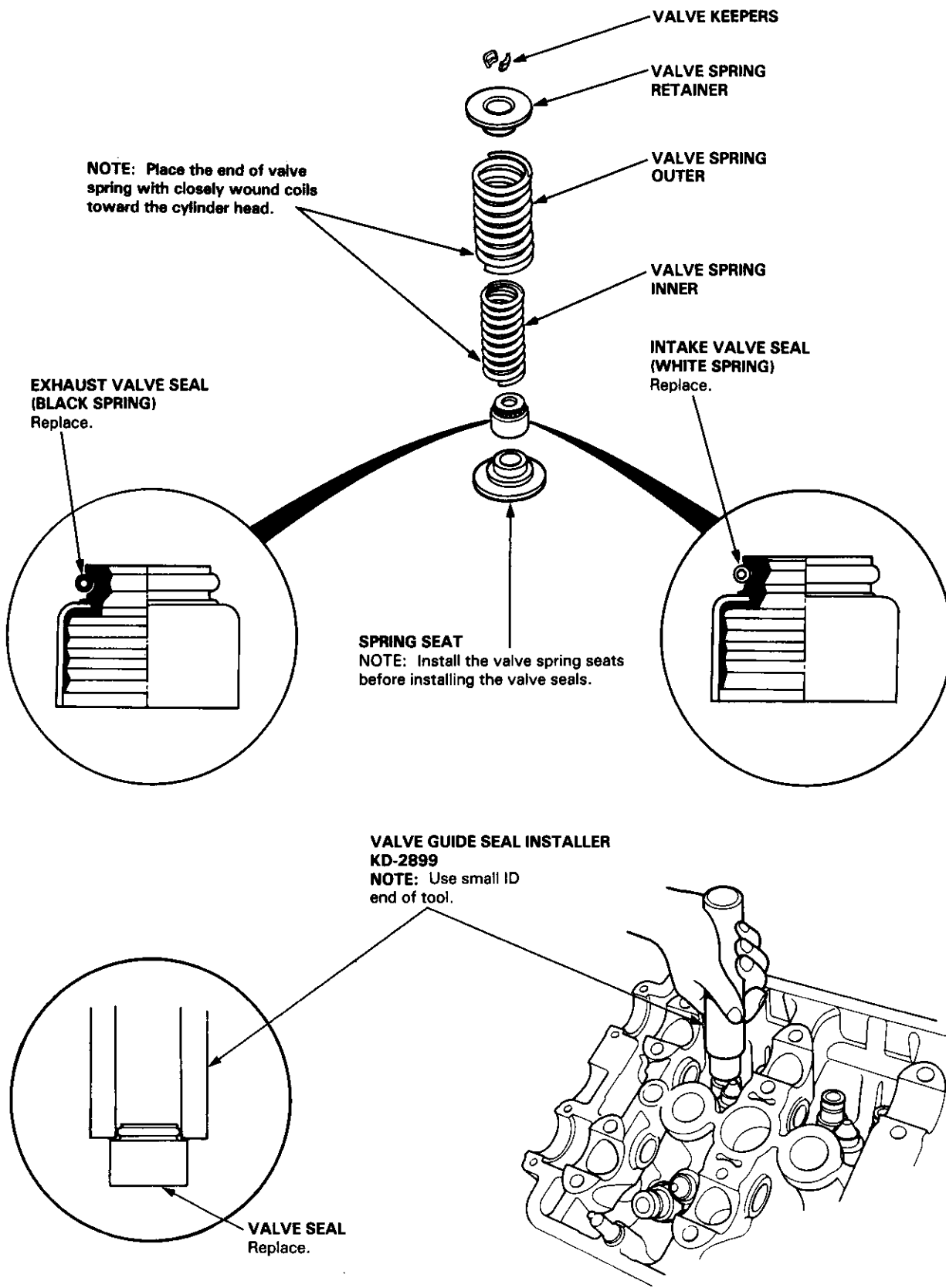

Valves, Valve Springs and Valve Seals

Valve Installation

- When installing valves in cylinder head, coat valve stems with oil before inserting into valve guides, and make sure valves move up and down smoothly.
- When valves and springs are in place, lightly tap the end of each valve stem two or three times to ensure proper seating of valve and valve keepers (use hammer grip bottom).

NOTE: Tap the valve stem only along its axis so you do not bend the stem.

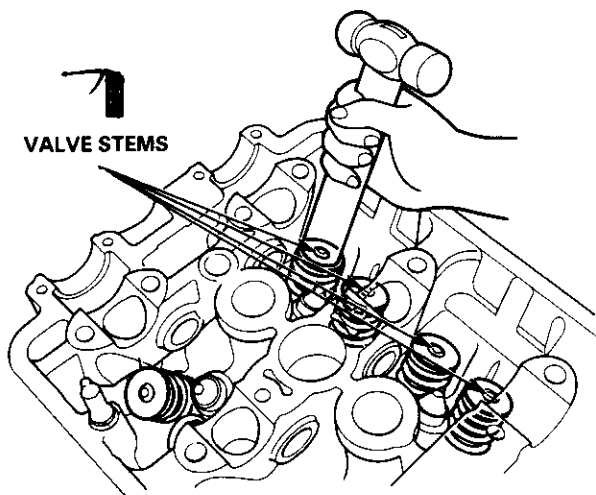

Rocker Arms

Installation

1. Install the rocker arms in the reverse order of removal:
 - Valve adjusting locknuts should be loosened and adjusting screw backed off before installation.
 - The component parts must be reinstalled in the original locations.
2. Install the lost motion assembly.
3. Install the rocker arms while passing the rocker arm shaft through the cylinder head.

NOTE: Removed the rubber band after installing the rocker arms.

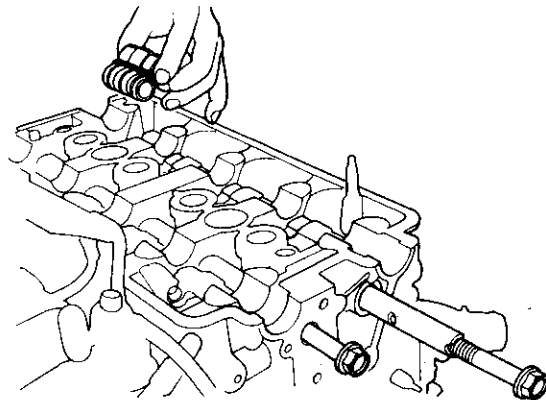

4. Install the rocker shaft orifices. If the holes in the rocker arm shaft and cylinder head are not in line with each other, threads a 12 mm bolt into the rocker arm shaft and rotate the shaft.

NOTE:

- The shapes of the rocker shaft orifices for the intake and exhaust are different. The orifices must be installed in the original locations.
- Clean and install the rocker shaft orifices with new O-rings.

EXHAUST ROCKER
SHAFT ORIFICE
Clean.

O-RING
Replace.

INTAKE ROCKER
SHAFT ORIFICE
Clean.

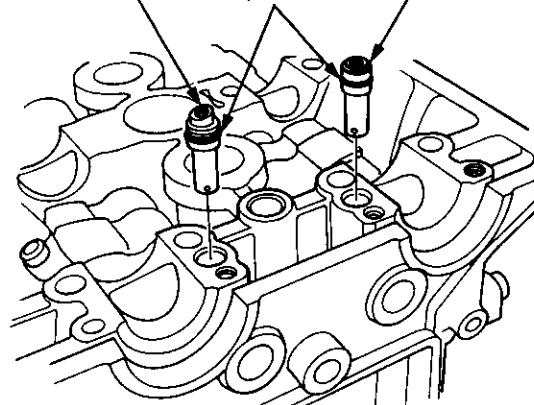



Cylinder Head

Installation

1. Install the cylinder head in the reverse order of removal:
 - Always use new head and manifold gaskets.
 - The cylinder head gasket is a metal gasket. Take care not to bend it.
 - Rotate the crankshaft, set the No. 1 piston at TDC (page 6-106).
2. Install the cylinder head gasket and dowel pins on the cylinder head.

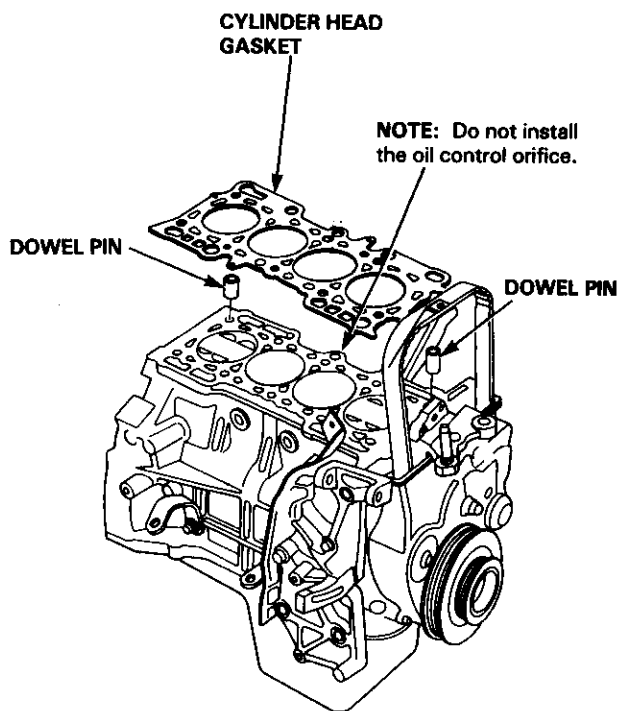

3. Tighten the cylinder head bolts sequentially in three steps.

1st step torque: 40 N·m (4.0 kg·m, 29 lb·ft)

2nd step torque: 70 N·m (7.0 kg·m, 51 lb·ft)

3rd step torque: 100 N·m (10.0 kg·m, 72 lb·ft)

NOTE:

- We recommend using a beam-type torque wrench. When using a preset-type torque wrench, be sure to tighten slowly and not to overtighten.
- If a bolt makes any noise while you are torquing it, loosen the bolt and retighten it from the 1st step.

CYLINDER HEAD BOLTS TORQUE SEQUENCE

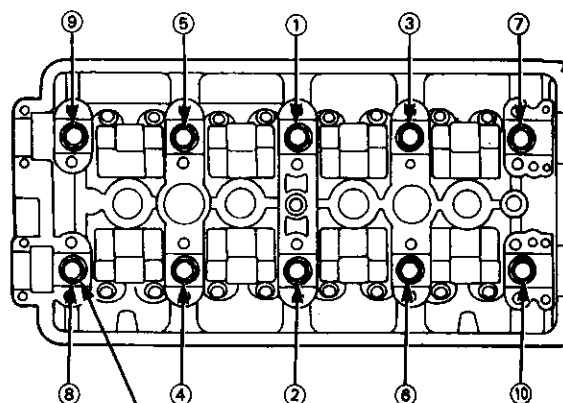

CYLINDER HEAD BOLTS

12 x 1.25 mm

100 N·m (10.0 kg·m, 72 lb·ft)

Apply clean engine oil to bolt threads and under bolt heads.

(cont'd)

Cylinder Head

Installation (cont'd)

4. Install the intake manifold and tighten the nuts in a crisscross pattern in 2 or 3 steps, beginning with the inner nuts.

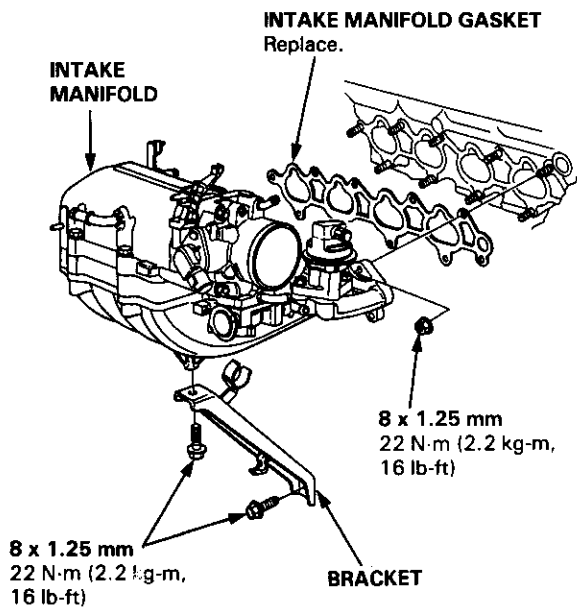

5. Install the exhaust manifold and brackets. Tighten the nuts in a crisscross pattern in 2 or 3 steps, beginning with the inner nuts.

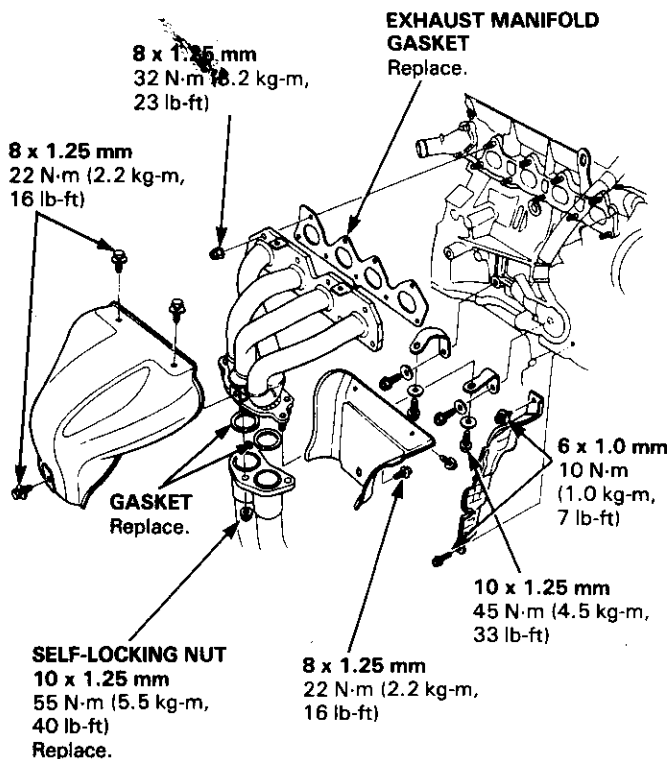

6. Install the camshafts and camshaft oil seals.

NOTE:

- Install the camshafts with keyway facing up.
- Install the oil seal with the spring side facing in.
- The oil seal housing surface should be dry.

7. Clean and install the oil control orifice with new O-ring in the oil passage of the No. 3 camshaft holder.

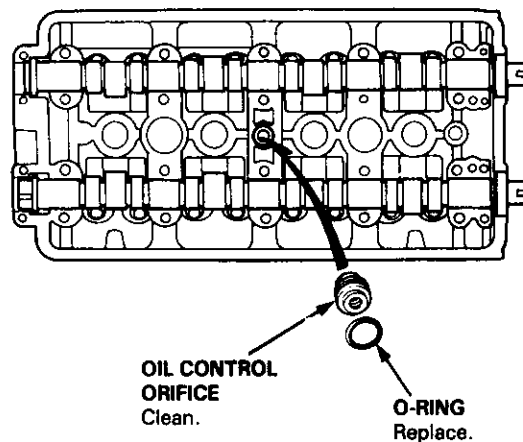

8. Apply liquid gasket to the head mating surface of the No. 1 and No. 5 camshaft holders on both the intake and exhaust side. Confirm that the camshaft keyway are face up, then place the holders, together with the No. 2, No. 3 and No. 4 camshaft holders, on the cylinder head.

NOTE: The arrows marked on the camshaft holders should point to the timing belt.

CAMSHAFT HOLDERS

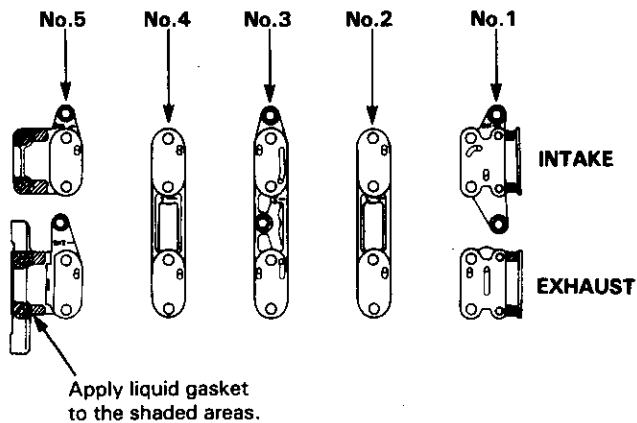



9. Temporarily tighten the bolts of the camshaft holders and the camshaft holder pipes.

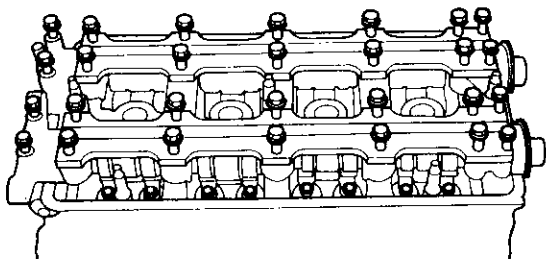

10. Push the camshaft oil seal securely against the base of the camshaft holder.

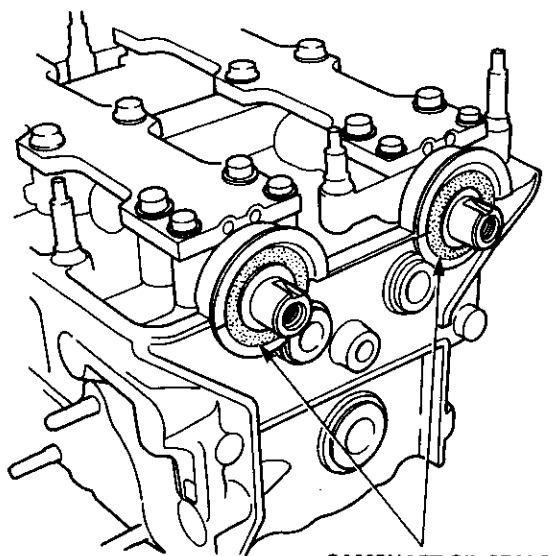

11. Tighten the bolts in the sequence shown below.

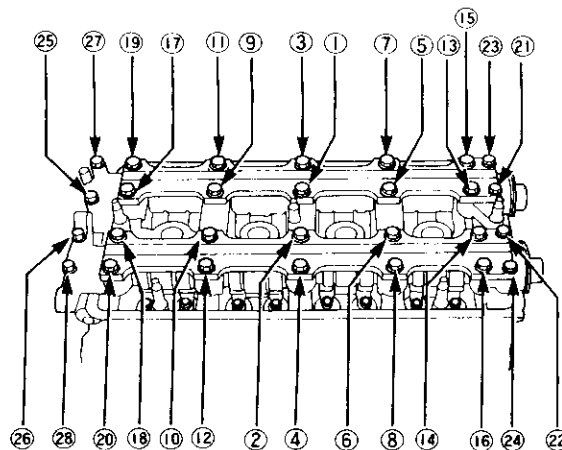

- ①—⑳ : 8 x 1.25 mm
26 N·m (2.6 kg·m, 19 lb·ft)
㉑—㉘ : 6 x 1.0 mm
12 N·m (1.2 kg·m, 9 lb·ft)

12. Install the back cover of the timing belt.

13. Install the camshaft pulleys.

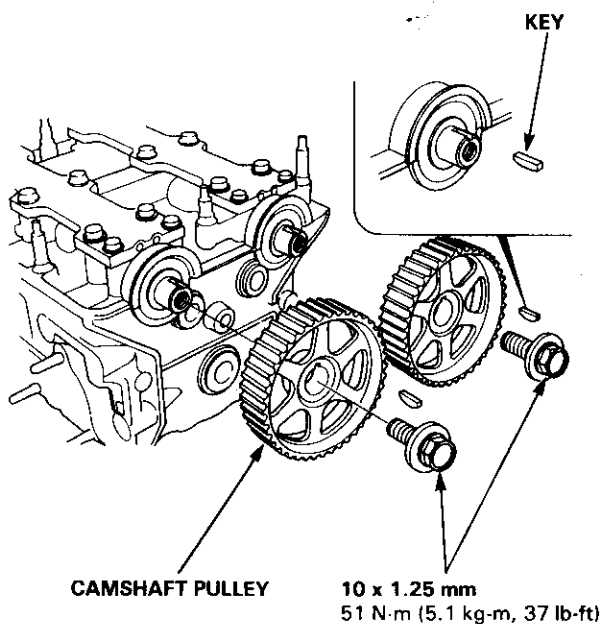

(cont'd)

Cylinder Head

Installation (cont'd)

14. Install the timing belt in the reverse order of removal. Adjust the valve clearances (page 6-115)
— Before installing the timing belt, position the crankshaft and camshaft pulleys as shown

CAMSHAFT TDC POSITION:

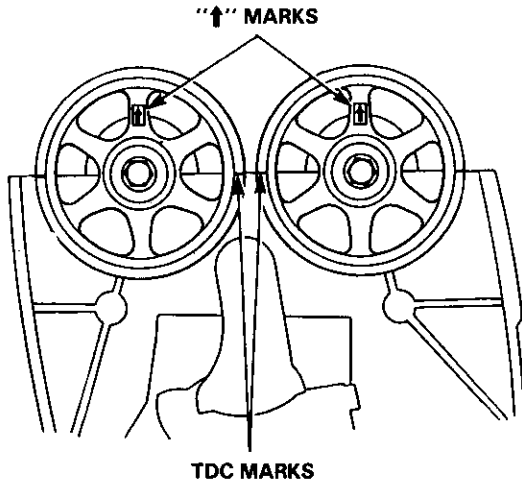

CRANKSHAFT TDC POSITION:

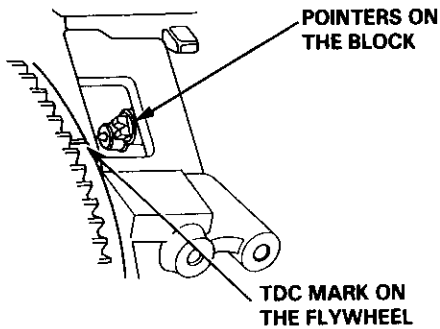

15. Install the special tool on the intake camshaft pulley.

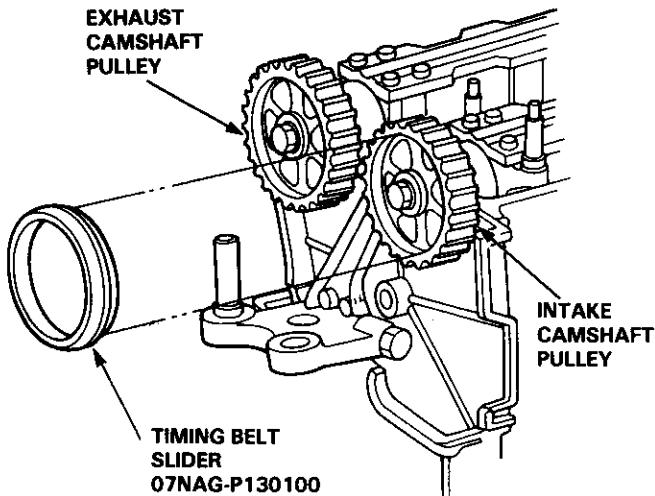

16. Install the timing belt.

NOTE:

- If the auto-tensioner has been extended and the timing belt cannot be installed, remove the auto-tensioner, compress it and reinstall it (page 6-112).
- Take care not to damage the timing belt when installing it.

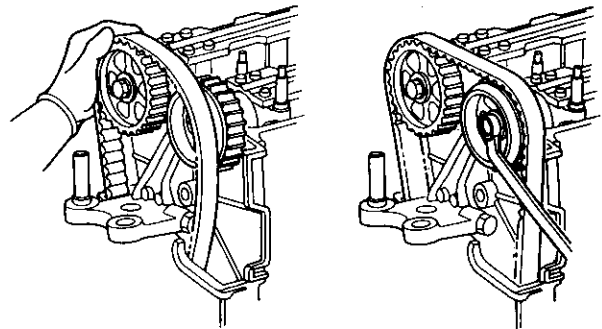

17. Tighten the maintenance bolt to make the auto-tensioner functional.

NOTE: Turn the maintenance bolt by hand until it stops.

Auto-tensioner fixed in place.

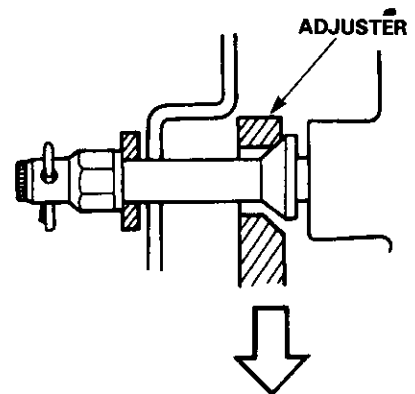

Auto-tensioner functional.

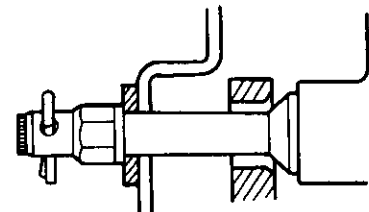



Timing Belt and Timing Balancer Belt

Illustrated Index

NOTE:

- Refer to page 6-106 for positioning crankshaft and pulley before installing timing belt.
- Before removing, mark direction of rotation on each belt.

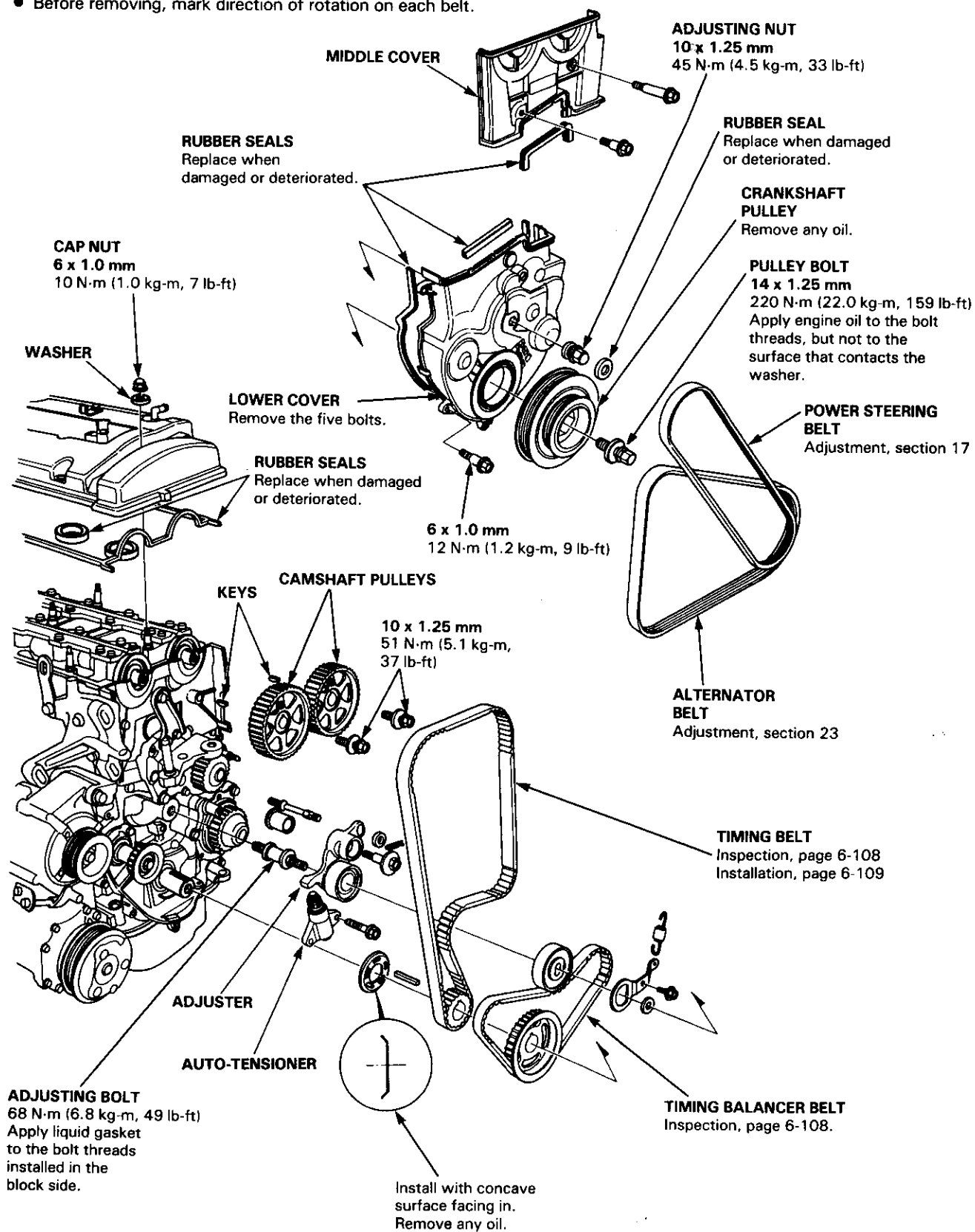

Timing Belt

Inspection

1. Disconnect the alternator terminal and the connector, then remove the engine wire harness from the cylinder head cover.
2. Remove the cylinder head cover.
3. Remove the middle cover.
4. Inspect the timing belt for cracks and oil or coolant soaking.

NOTE:

- Replace the belt if oil or coolant soaked.
- Remove any oil or solvent that gets on the belt.

Inspect this area for wear.

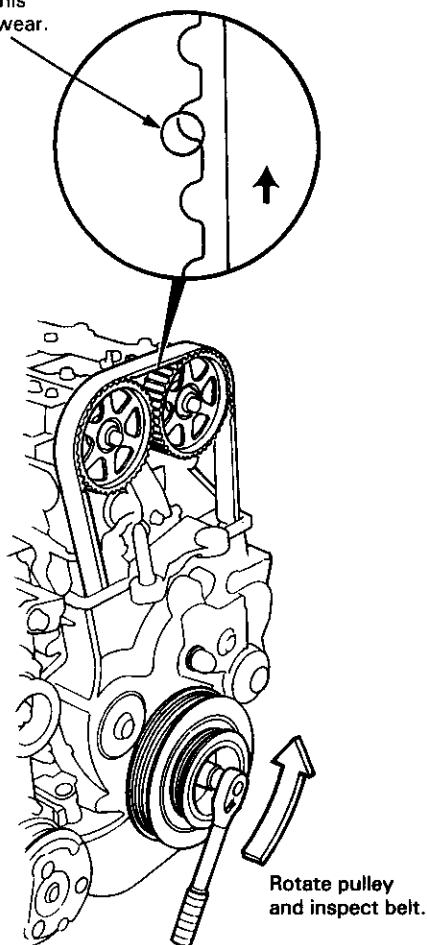

5. After inspecting, retorque the crankshaft pulley bolt to 220 N·m (22.0 kg·m, 159 lb·ft).

Timing Balancer Belt

Inspection

1. Disconnect the alternator terminal and the connector, then remove the engine wire harness from the cylinder head cover.
2. Remove the cylinder head cover.
3. Remove the middle cover.
4. Remove the crankshaft pulley.
5. Remove the lower cover.
6. Install the crankshaft pulley.
7. Inspect the timing belt for cracks and oil or coolant soaking.

NOTE:

- Replace the belt if oil or coolant soaked.
- Remove any oil or solvent that gets on the belt.

Inspect this area for wear.

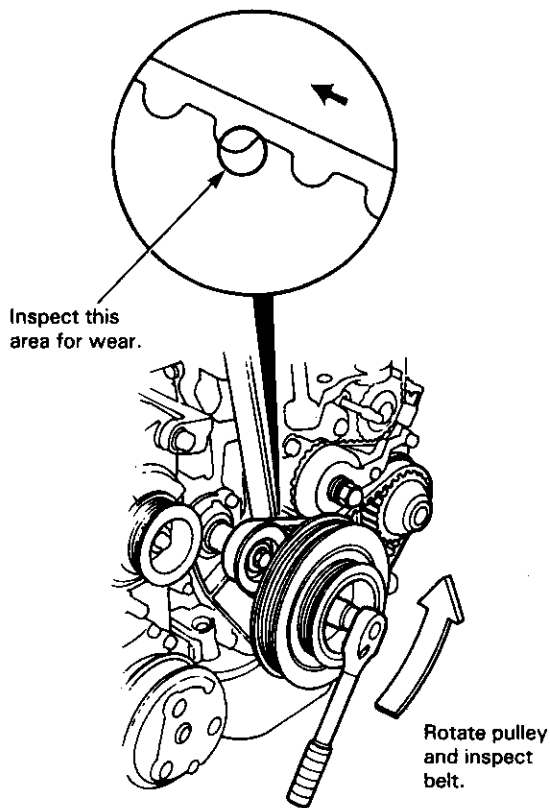

8. After inspecting, retorque the crankshaft pulley bolt to 220 N·m (22.0 kg·m, 159 lb·ft).

NOTE: Refer to page 6-113 for timing balancer belt tension adjustment.

Timing Belt and Timing Balancer Belt



Replacement

CAUTION: Inspect the water pump when replacing the timing belt (page 10-12).

NOTE: Turn the crankshaft so that the No. 1 piston is at TDC (page 6-106).

1. Remove the splash shield.

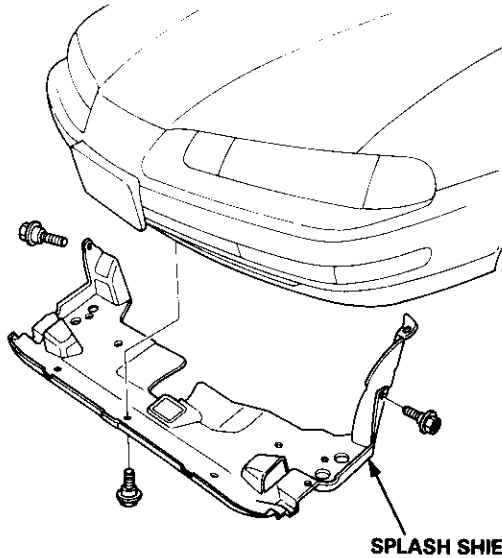

2. Disconnect the connector, then remove the cruise control actuator.

NOTE:

- Do not disconnect the control cable.
- Take care not to bend the cable when removing the actuator. Always replace a kinked cable with a new one.

CRUISE CONTROL ACTUATOR

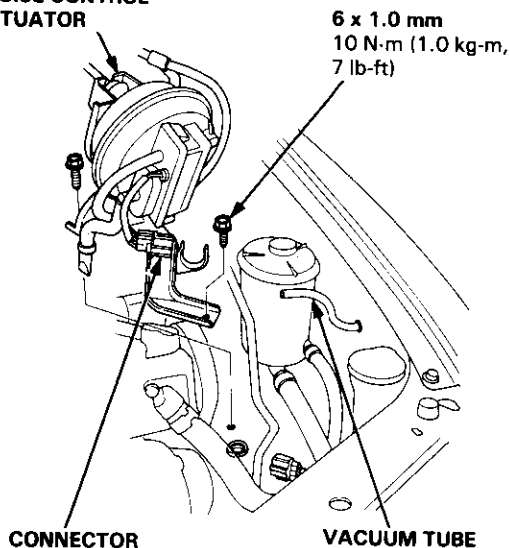

3. Remove the mounting bolts, nuts and belt from the power steering (P/S) pump.

NOTE:

- Do not disconnect the P/S pipe and hose.
- After installing, adjust the tension of the P/S pump belt (see section 17).

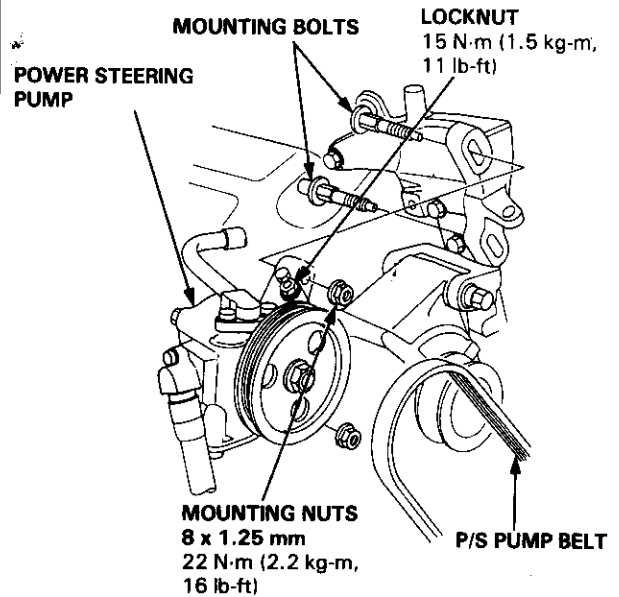

4. Disconnect the alternator terminal and the connector, then remove the engine wire harness from the body side.

5. Loosen the alternator mounting bolt, nut and the adjusting nut, then remove the alternator belt.

NOTE: After installing, adjust the tension of the alternator belt (see section 23).

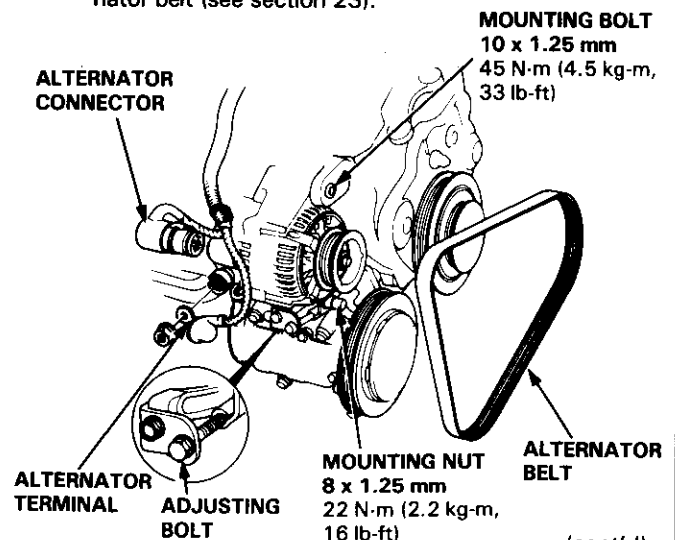

(cont'd)

Timing Belt and Timing Balancer Belt

Replacement (cont'd)

6. Remove the cylinder head cover.
7. Remove the middle cover.
8. Remove the side engine mount.

12 x 1.25 mm
55 N-m (5.5 kg-m,
40 lb-ft)

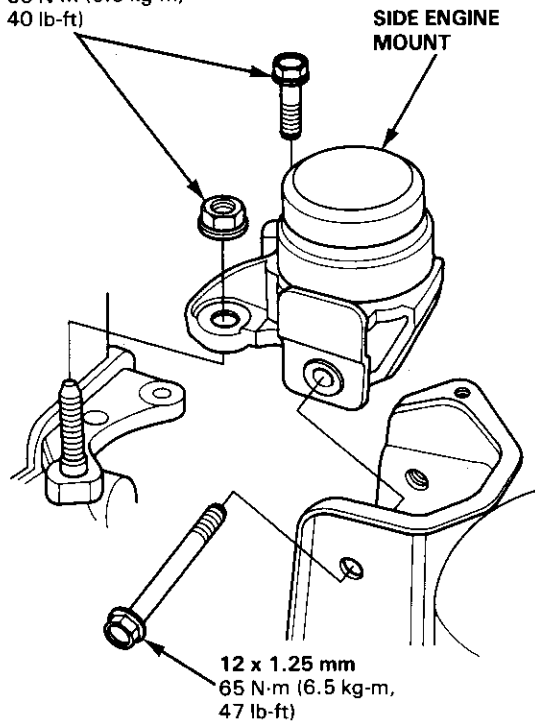

9. Remove the dipstick and the pipe

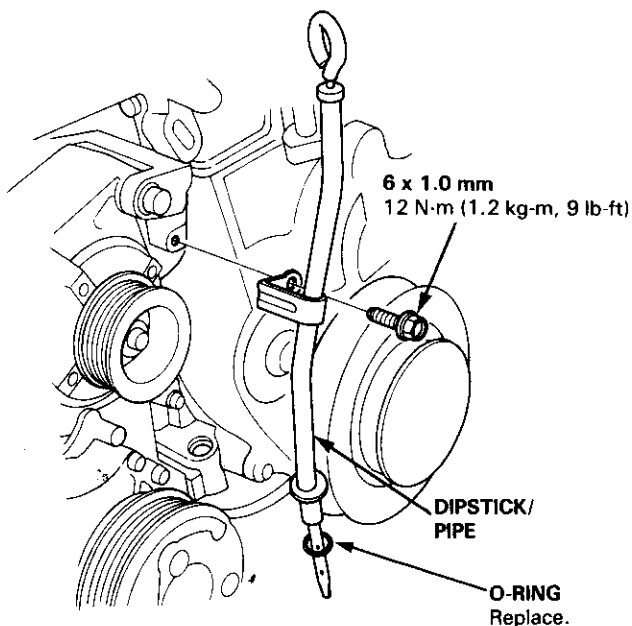

10. Remove the crankshaft bolt and the pulley.
Remove the two rear bolts from the center beam to allow the engine to drop down and give clearance to remove the lower cover.
11. Remove the adjuster rubber seal. Do not loosen the adjusting nut.
12. Remove the lower cover.
13. Loosen the adjusting nut. Push on the pulley to remove tension from the timing balancer belt, then tighten the adjusting nut.

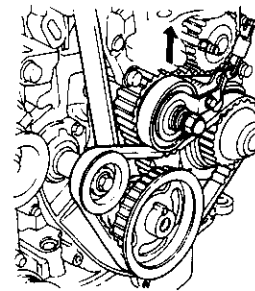

14. Remove the timing balancer belt.
15. Remove the timing belt.
16. Remove the auto-tensioner.

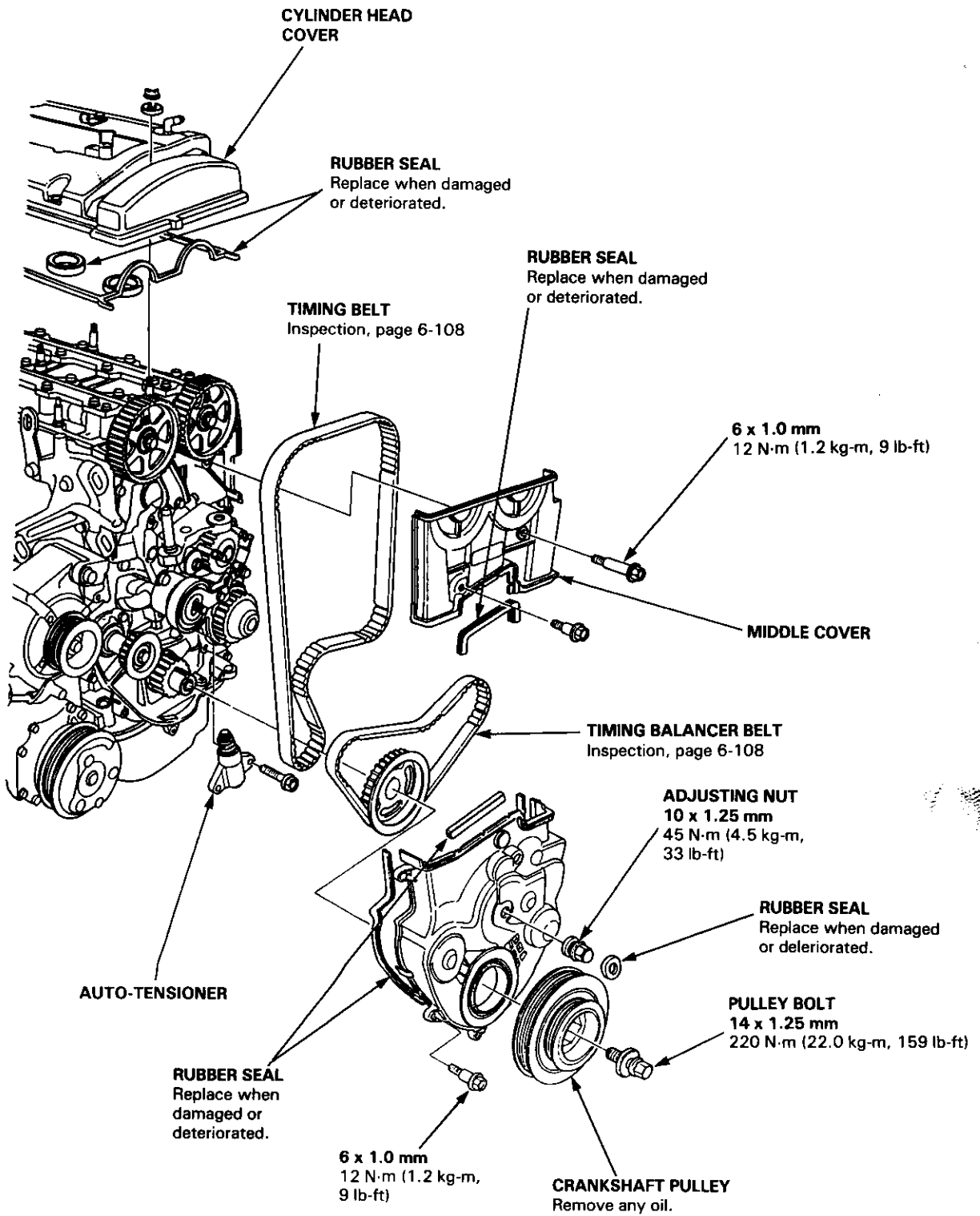

Timing Belt and Timing Balancer Belt

Replacement (cont'd)

17. Install the timing belt in the reverse order of removal.
— Before installing the timing belt, position the crankshaft and camshaft pulleys as shown

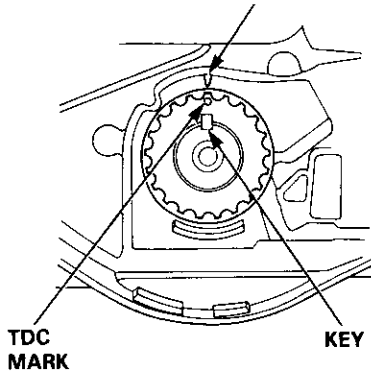
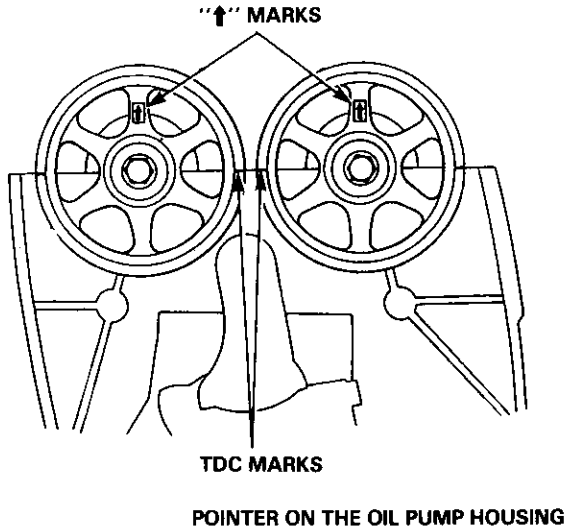

18. Hold the auto-tensioner with the maintenance bolt pointing up. Loosen and remove the maintenance bolt.

NOTE: Handle the auto-tensioner carefully so the oil inside does not spill or leak. Replenish the auto-tensioner with oil if any spills or leaks. The total capacity is 8 cc (1/4 fl oz).

19. Clamp the boss of the auto-tensioner in a vise. Use pieces of wood or a cloth to protect the boss.

NOTE: Do not grip the housing of the auto-tensioner.

20. Insert a flat blade screwdriver into the maintenance hole. Place the stopper (P/N 14540-P13-003) on the auto-tensioner while turning the screwdriver clockwise to compress the bottom.

NOTE: Take care not to damage the threads or the gasket contact surface with the screwdriver.

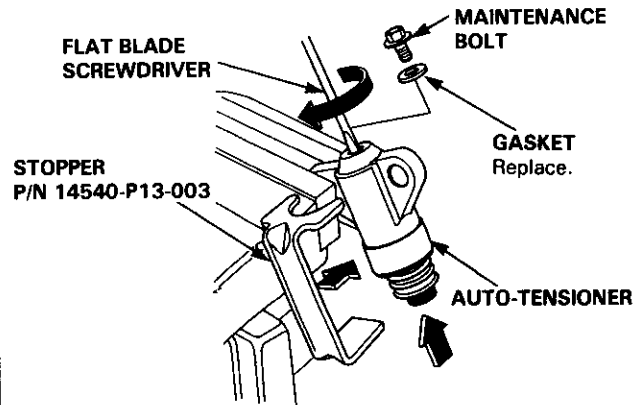

21. Remove the screwdriver and reinstall the maintenance bolt.

NOTE: Be sure to use a new gasket.

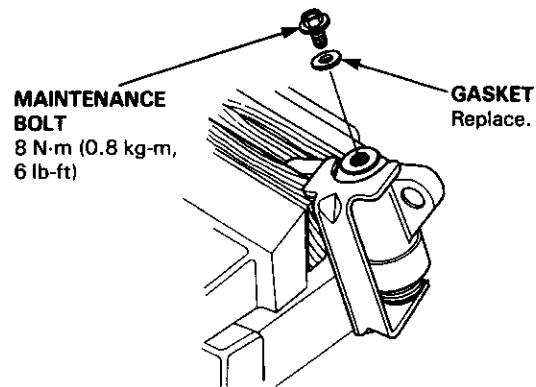

22. Make sure no oil is leaking around the maintenance bolt. Install the auto-tensioner on the engine.

NOTE: Make sure the stopper stays in place.

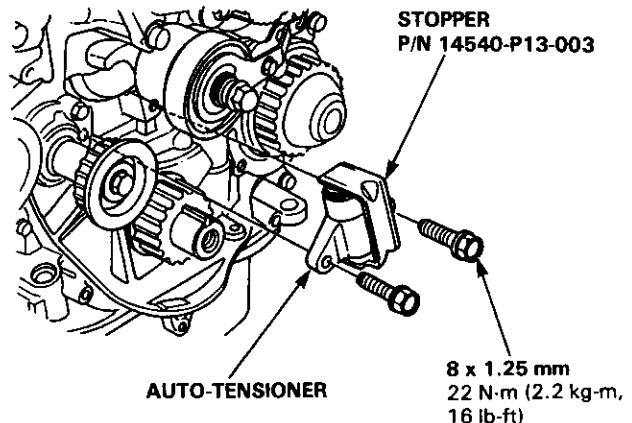



23. Remove the stopper.

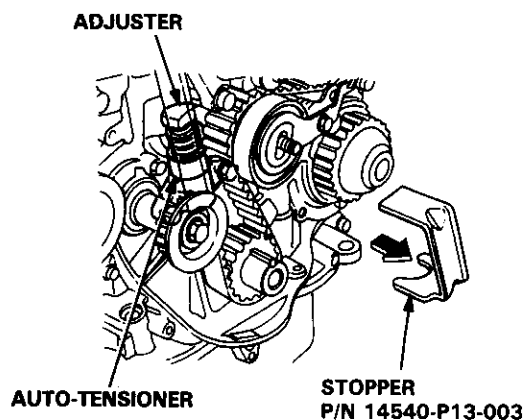

24. Make sure the crankshaft is positioned with the No. 1 cylinder at TDC.

25. Align the groove on the front balancer shaft pulley with the pointer on the oil pump housing as shown.

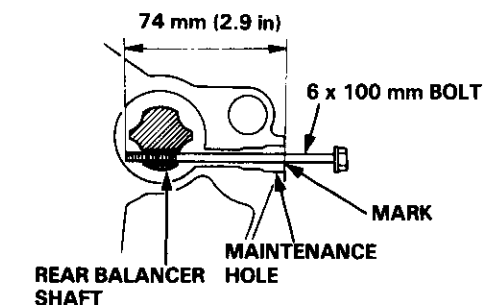

FRONT TIMING BALANCER BELT DRIVEN PULLEY

Align the groove of the front driven pulley with the pointer on the oil pump housing.

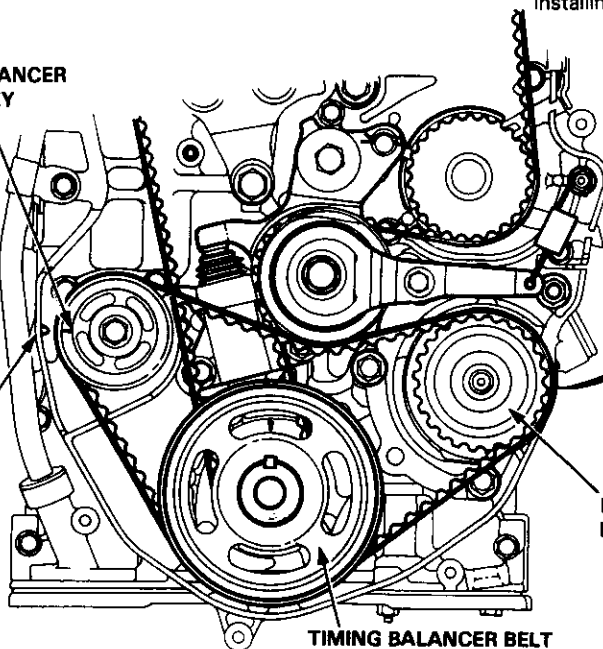

Set the crankshaft at TDC.

26. Align the rear balancer shaft pulley by using a 6 x 100 mm bolt or equivalent as an alignment tool. Scribe a line 74 mm (2.9 in) from the end of the bolt. Insert the bolt into the maintenance hole to the scribed line.

27. Loosen the adjusting nut and verify that the timing balancer belt adjuster moves freely.

28. Install the timing balancer belt. Remove the 6 x 100 mm bolt from the rear balancer shaft.

29. Turn the crankshaft pulley about one turn, then tighten the adjusting nut to the specified torque.

NOTE: Both belt adjusters are spring-loaded to properly tension the belts. Do not apply any extra pressure to the pulleys or tensioners while performing the adjustment.

REAR BALANCER SHAFT

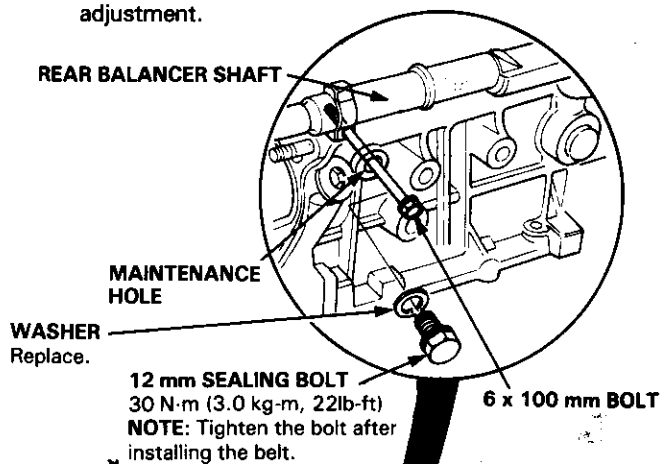

(cont'd)

Timing Belt and Timing Balancer Belt

Replacement (cont'd)

30. Install the lower cover.

31. Install a rubber seal around the adjusting nut. Do not loosen the nut.

32. Install the middle cover.

33. Install the crankshaft pulley.

34. Coat the threads and seating face of the pulley bolt with engine oil. Install and tighten to the specified torque.

Specified torque: 220 N-m (22.0 kg-m, 159 lb-ft)

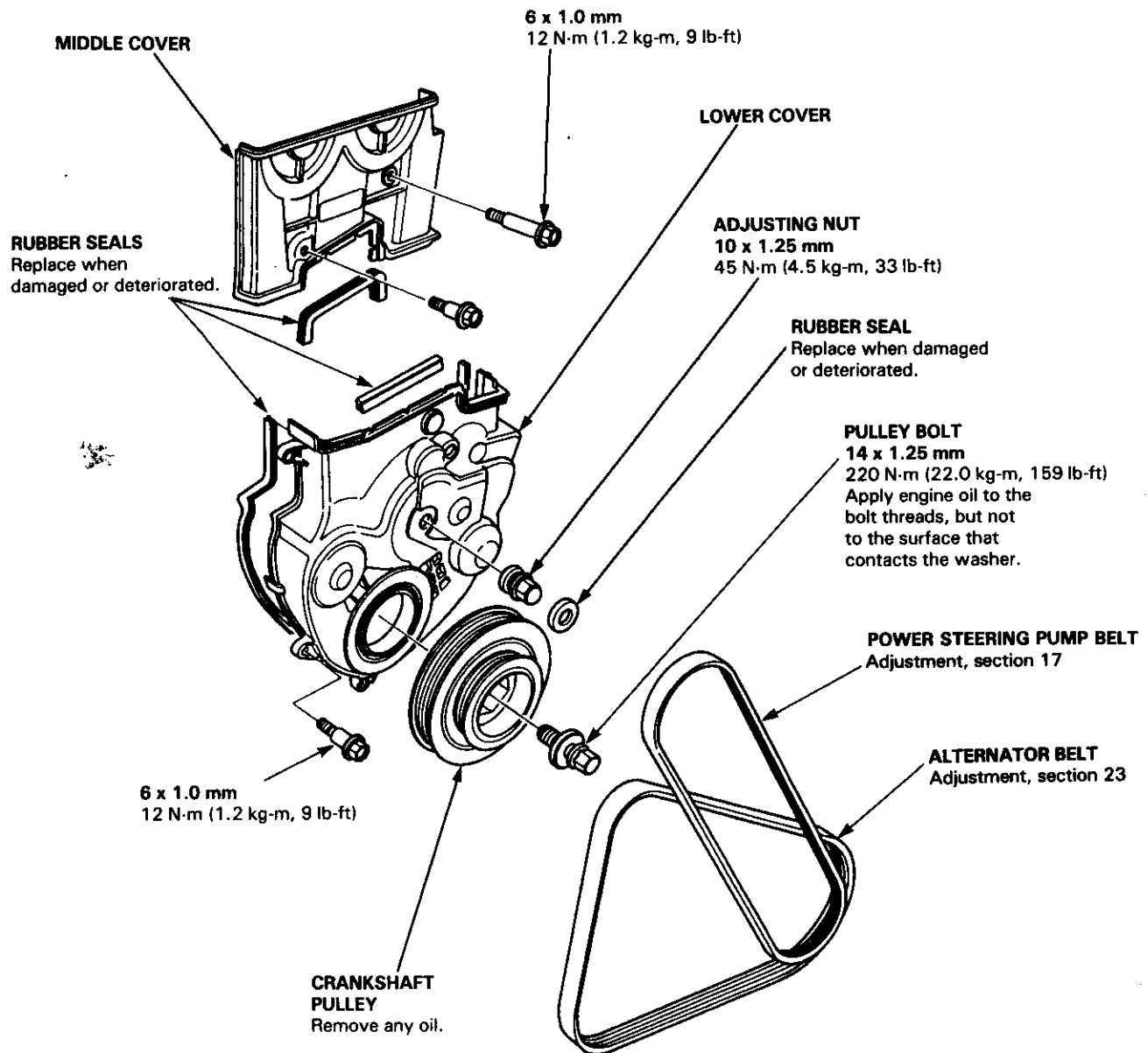



Valve Clearance

Adjustment

NOTE:

- Valves should be adjusted cold when the cylinder head temperature is less than 100°F (38°C).
- After adjusting, retorque the crankshaft pulley bolt to 220 N-m (22.0 kg-m, 159 lb-ft).

1. Remove the cylinder head cover.

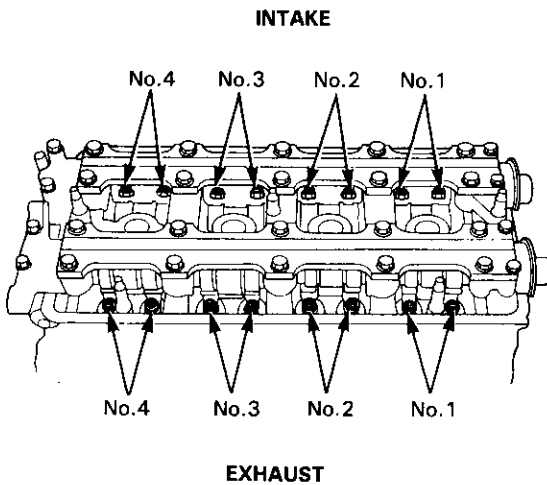

2. Set No.1 piston at TDC. "↑" marks on the pulleys should be at top, and TDC grooves on the pulleys should align with cylinder heads surface.

Number 1 piston at TDC:

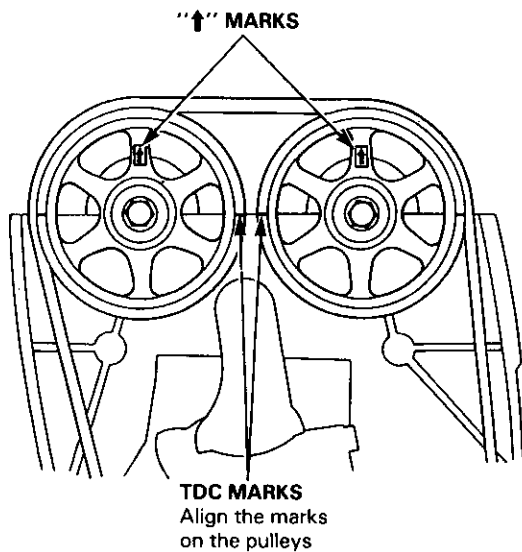

3. Adjust valves on No.1 cylinder.

Valve Clearance:

Intake: 0.15–0.19 mm (0.006–0.007 in)

Exhaust: 0.17–0.21 mm (0.007–0.008 in)

4. Loosen locknut and turn adjusting screw until feeler gauge slides back and forth with slight amount of drag.

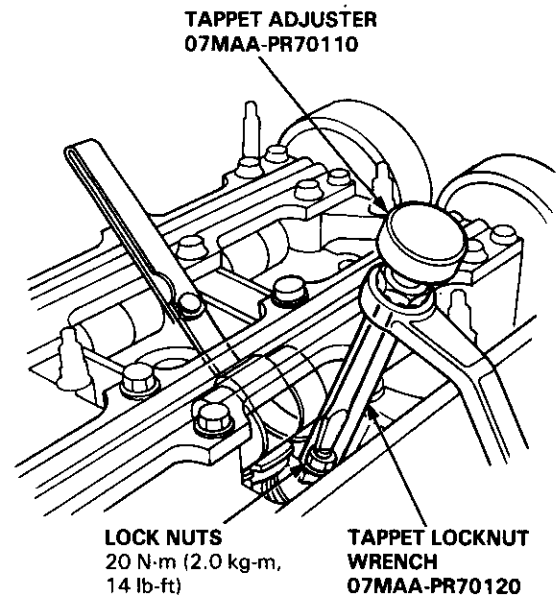

5. Tighten the locknut and check clearance again. Repeat adjustment if necessary.

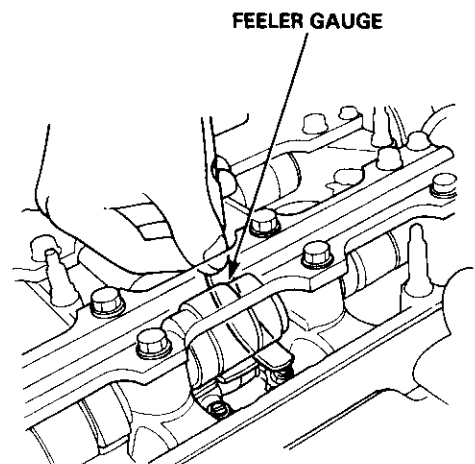

(cont'd)

Valve Clearance

Adjustment (cont'd)

6. Rotate crankshaft 180° counterclockwise (camshaft pulleys turns 90°). The "↑" marks should be at exhaust side. Adjust valves on No.3 cylinder.

Number 3 piston at TDC:

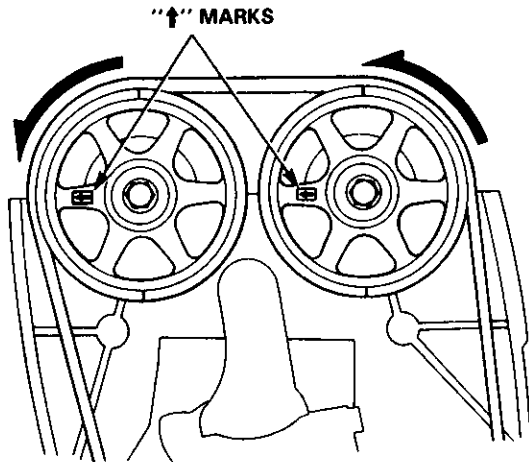

7. Rotate crankshaft 180° counterclockwise to bring No. 4 piston to TDC. The TDC grooves are once again aligned. Adjust valves on No. 4 cylinder.

Number 4 piston at TDC:

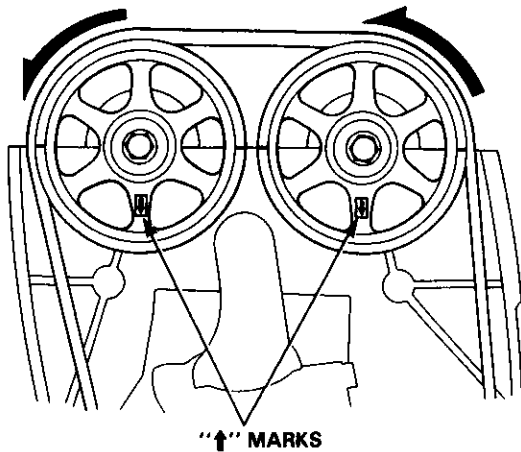

8. Rotate crankshaft 180° counterclockwise to bring No. 2 piston to TDC. The "↑" marks should be at intake side. Adjust valves on No. 2 cylinder.

Number 2 piston at TDC:

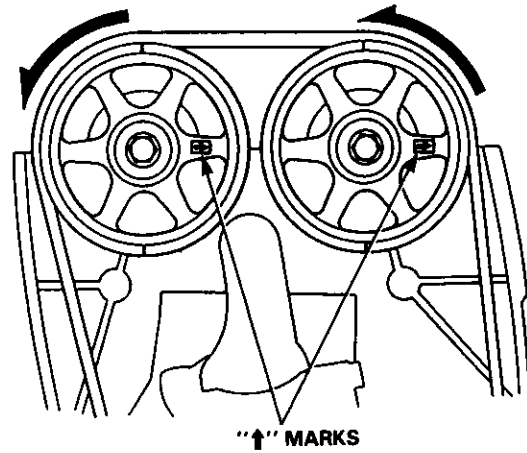

Engine Block

Special Tools	7-2
Illustrated Index	7-3
Flywheel and Drive Plate	
Replacement	7-7
Connecting Rod and Crankshaft	
End Play	7-7
Main Bearings	
Clearance	7-8
Selection	7-9
Connecting Rod Bearings	
Clearance	7-10
Selection	7-11
Crankshaft, Balancer Shafts and Pistons	
Removal	7-12
Crankshaft	
Inspection	7-15
Pistons	
Inspection	7-16
Installation	7-25
Cylinder Block	
Inspection	7-17
Bore Honing (H23A1, H22A1 engines)	7-18
Bore Honing (F22A1 engine)	7-19
Piston Pins	
Removal	7-19
Installation	7-20
Inspection	7-21
Connecting Rods	
Selection	7-20
Piston Rings	
End Gap	7-22
Replacement	7-23
Ring-to-Groove Clearance	7-23
Alignment	7-24
Crankshaft Oil Seal	
Installation	7-25
Crankshaft and Balancer Shaft Oil Seal	
Installation (engine removal is not required)	7-30
Crankshaft and balancer shafts	
Instration	7-26
Balancer Shafts	
Inspection	7-31



Special Tools

Ref. No.	Tool Number	Description	Qty	Page Reference
①	07GAF — PH60300	Piston Pin Base Insert	1	7-19, 20
②	07GAF — PH70100	Pilot Collar	1	7-19, 20
③	07GAF — SE00200	Hub Assembly Guide Attachment	1	7-30
④	07HAF — PL20102	Piston Base Head	1	7-19, 20
⑤	07LAD — PT3010A	Seal Driver	1	7-30
⑥	07LAF — PV00100 or 07924 — PD20003	Ring Gear Holder	1	7-7
⑦	07746 — 0030300	Attachment, 30 mm I.D.	1	7-30
⑧	07749 — 0010000	Driver	1	7-25, 30
⑨	07948 — SB00101	Driver Attachment	1	7-25, 30
⑩	07973 — PE00310	Piston Pin Driver Shaft	1	7-19, 20
⑪	07973 — PE00320	Piston Pin Driver Head	1	7-19, 20
⑫	07973 — 6570500	Piston Base	1	7-19, 20
⑬	07973 — 6570600	Piston Base Spring	1	7-19, 20



①



②

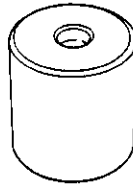

③

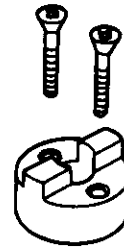

④

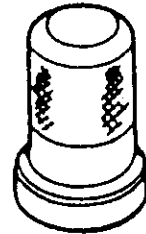

⑤

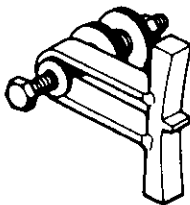

⑥



⑦

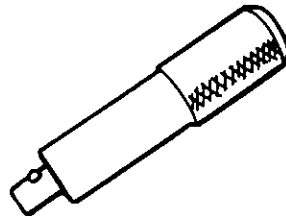

⑧

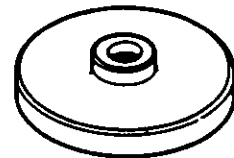

⑨

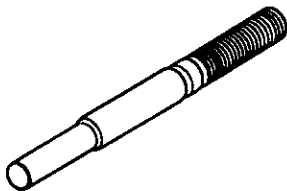

⑩



⑪

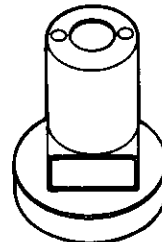

⑫



⑬

Illustrated Index



 Lubricate all internal parts with engine oil during reassembly.

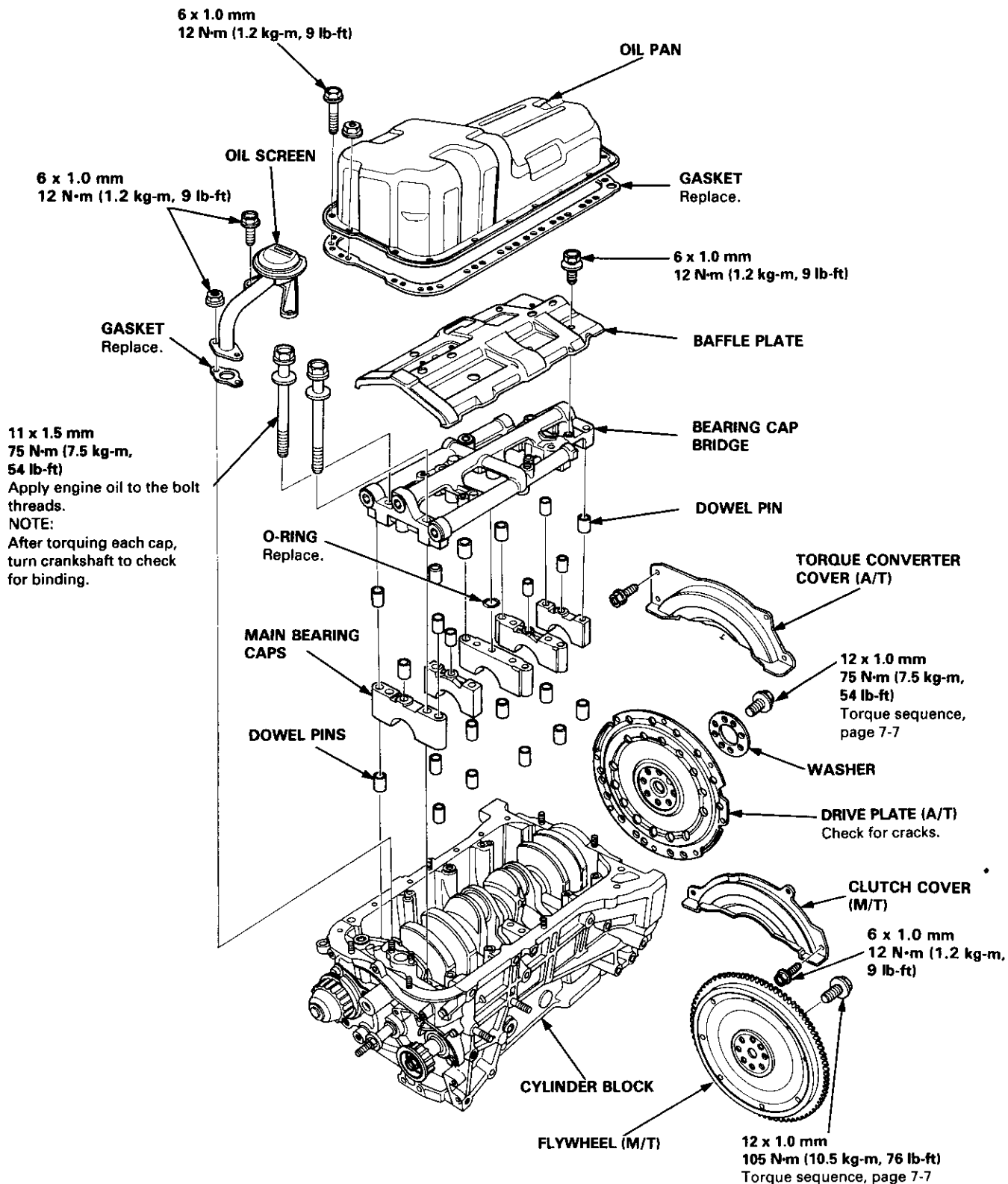

(cont'd)

Illustrated Index

(cont'd)

 Lubricate all internal parts with engine oil during reassembly.

NOTE:

- Apply liquid gasket to the mating surfaces of the right side cover and oil pump case before installing them.
- Use liquid gasket, part No. 08718 — 0001.

CRANKSHAFT
End play, page 7-7
Runout, Taper and
Out-of-Round, page 7-15
Installation, page 7-26

MAIN BEARINGS
Oil clearance, page 7-8
Selection, page 7-9
NOTE: New main bearings must
be selected by matching crank and
block identification markings.

THRUST WASHERS
Grooved sides face outward.
NOTE: Thrust washer thickness
is fixed and must not be changed
by grinding or shimming.

CRANKSHAFT OIL SEAL
Installation, pages 7-25 and 30

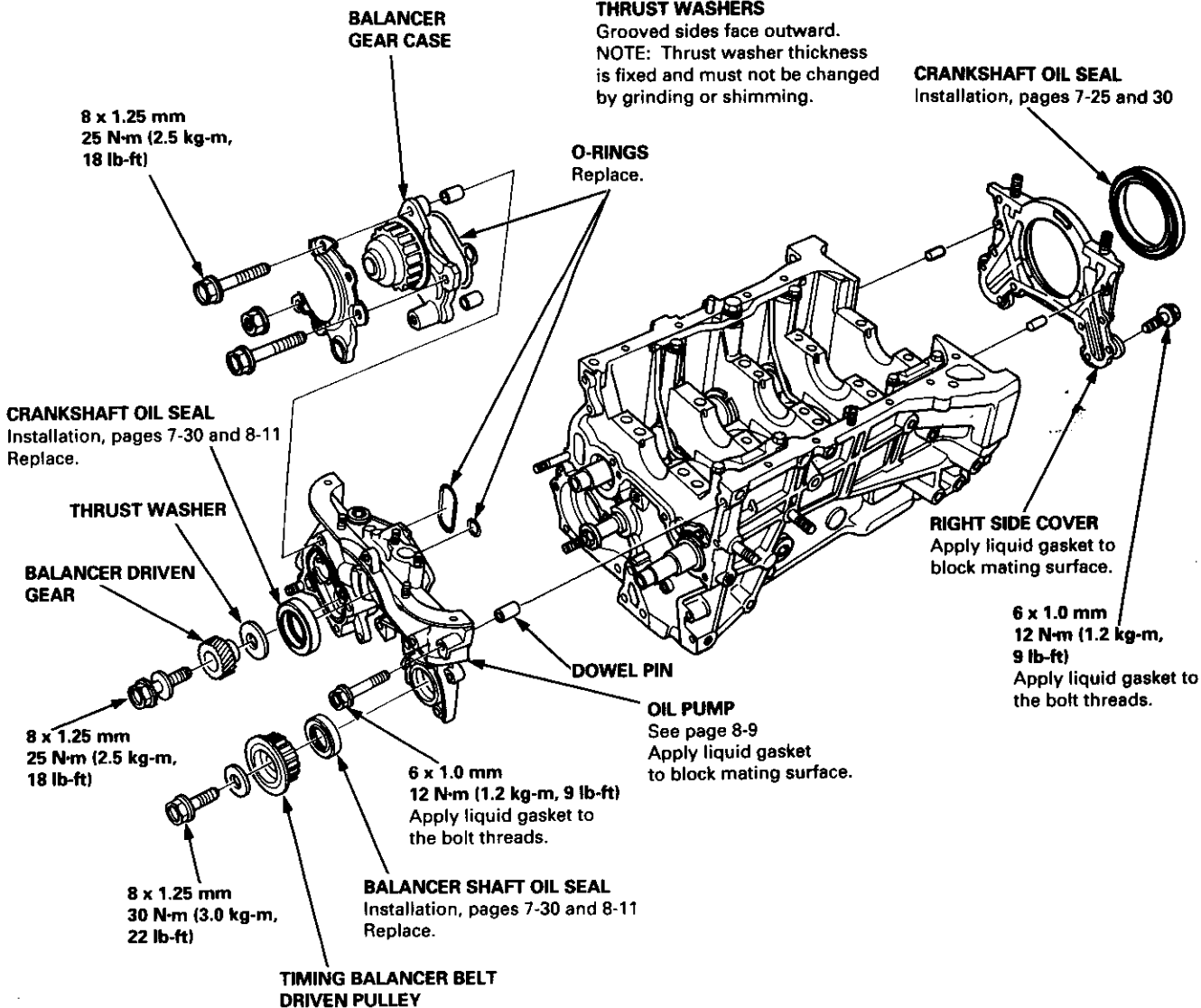

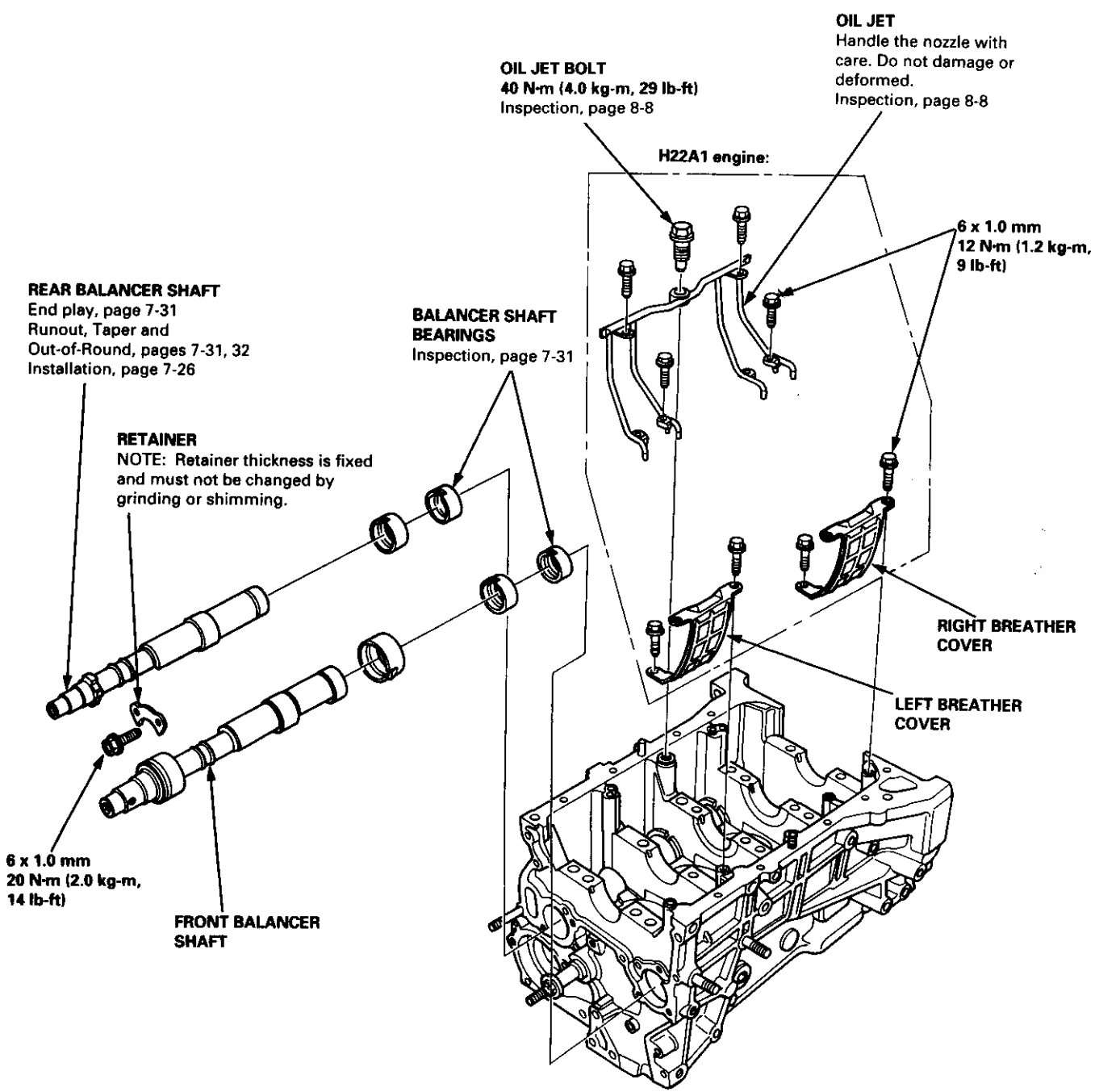

(cont'd)

Illustrated Index

(cont'd)

 Lubricate all internal parts with engine oil during reassembly.

NOTE: New rod bearings must be selected by matching connecting rod and crankshaft identification markings (pages 7-10, 11).

PISTON INSTALLATION DIRECTION

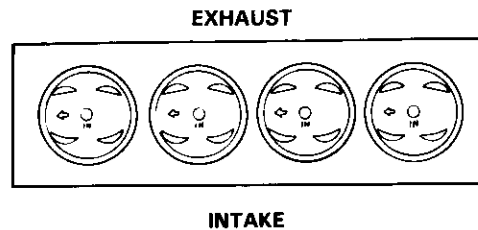

PISTON RINGS

Replacement, page 7-23
Measurement, pages 7-22, 23
Alignment, page 7-24

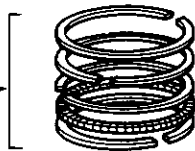

PISTON PIN

Removal, page 7-19
Installation page 7-20
Inspection, page 7-21

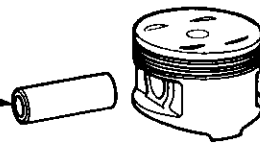

PISTON

Removal, page 7-12
Measurement, page 7-16

NOTE: To maintain proper clearance, match the letter on the piston top with the letter for each cylinder stamped on the block.

On the piston top	On the block
No letter	A or I
B	B or I

CONNECTING ROD

End play, page 7-7
Selection, page 7-20
Small end measurement, page 7-21

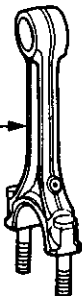

ENGINE BLOCK

Cylinder bore inspection, page 7-17
Warpage inspection, page 7-17
Cylinder bore honing, pages 7-18, 19
Inspect top of each cylinder bore for carbon build-up or ridge before removing piston.
Remove ridge if necessary, page 7-14

CONNECTING ROD BEARINGS

Clearance, page 7-10
Selection, page 7-11

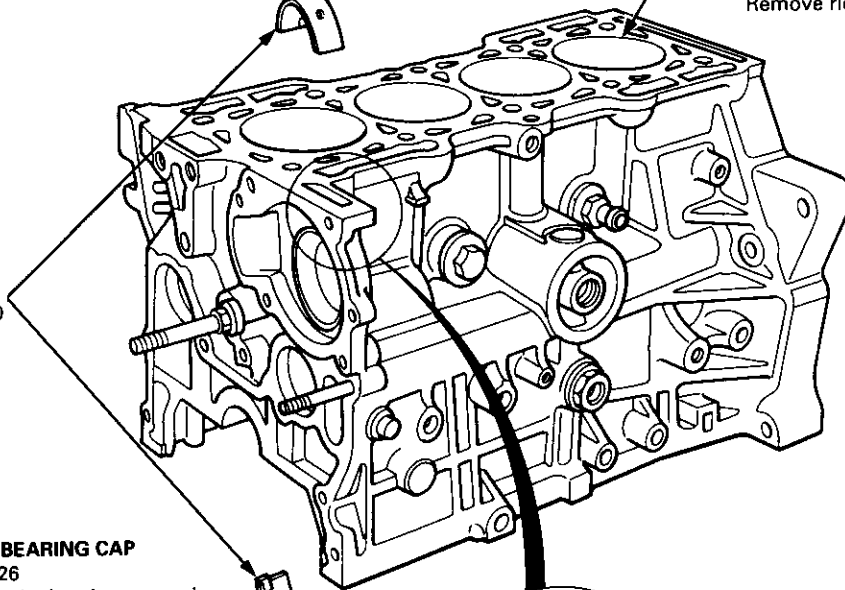

CONNECTING ROD BEARING CAP

Installation, page 7-26
NOTE: Install cap so the bearing recess is on the same side as the recess in the rod.



CONNECTING ROD NUT

9 x 0.75 mm
47 N·m (4.7 kg-m, 34 lb-ft)
After torquing each bearing cap, rotate crankshaft to check for binding.

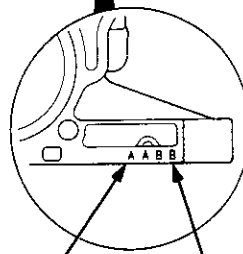

CYLINDER BORE SIZES

(A or I, B or I)

NOTE: To maintain proper piston clearance, match these letters with the letters on the pistons. The letters on the block read from left to right, No. 1 through No. 4 cylinders.

On the block	On the piston top
A or I	No letter
B or I	B

Flywheel and Drive Plate

Replacement

Manual Transmission:

Remove the eight flywheel bolts, then separate the flywheel from the crankshaft flange. After installation, tighten the bolts in the sequence shown.

RING GEAR HOLDER
07LAB — PV00100
or 07924 — PD20003

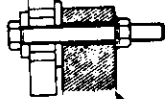

RING GEAR HOLDER
07LAB — PV00100
or 07924 — PD20003

ENGINE
BLOCK

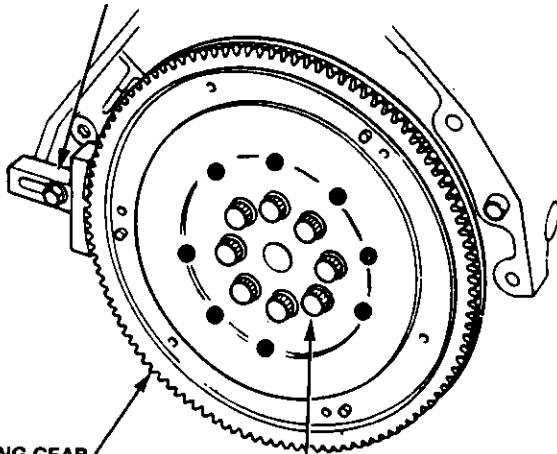

RING GEAR
Inspect ring gear
teeth for wear or damage.

12 x 1.0 mm
105 N·m (10.5 kg·m, 76 lb·ft)

Automatic Transmission:

Remove the eight drive plate bolts, then separate the drive plate from the crankshaft flange. After installation, tighten the bolts in the sequence shown.

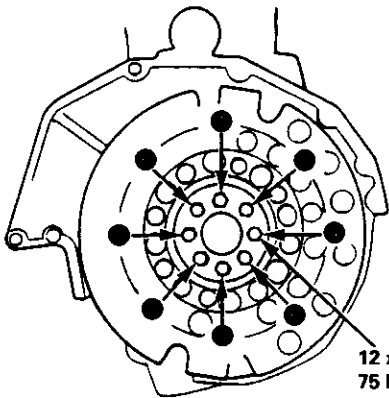

12 x 1.0 mm
75 N·m (7.5 kg·m,
54 lb·ft)

Connecting Rod and Crankshaft



End Play

Connecting Rod End Play:

Standard (New): 0.15 — 0.30 mm
(0.006 — 0.012 in)
Service Limit: 0.40 mm (0.016 in)

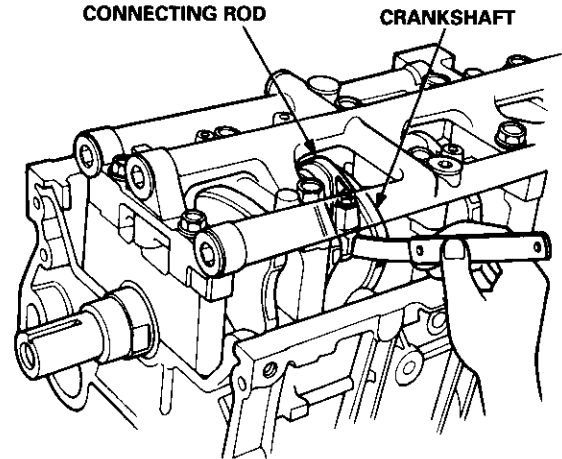

- If out-of-tolerance, install a new connecting rod.
- If still out-of-tolerance, replace the crankshaft (pages 7-11 and 7-26).

Push the crankshaft firmly away from the dial indicator, and zero the dial against the end of the crankshaft. Then pull the crankshaft firmly back toward the indicator; dial reading should not exceed service limit.

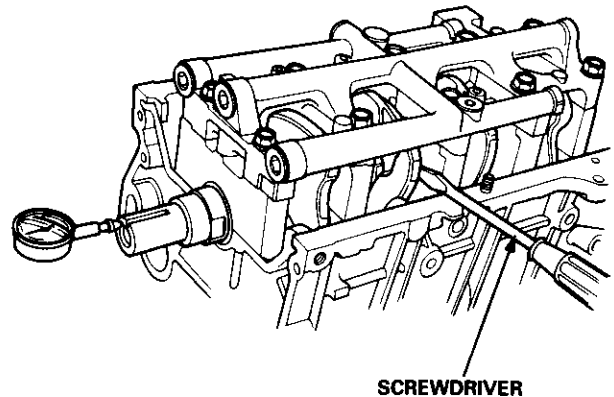

SCREWDRIVER

Crankshaft End Play:

Standard (New): 0.10 — 0.35 mm
(0.004 — 0.014 in)
Service Limit: 0.45 mm (0.018 in)

- If end play is excessive than the service limit, inspect the thrust washers and thrust surface on the crankshaft. Replace parts as necessary.

NOTE: Thrust washer thickness is fixed and must not be changed either by grinding or shimming. Thrust washers are installed with grooved sides facing outward.

Main Bearings

Clearance

1. To check main bearing-to-journal oil clearance, remove the main caps and bearing halves.
2. Clean each main journal and bearing half with a clean shop towel.
3. Place one strip of plastigage across each main journal.

NOTE: If the engine is still in the car when you bolt the main cap down to check clearance, the weight of the crankshaft and flywheel will flatten the plastigage further than just the torque on the cap bolt, and give you an incorrect reading. For an accurate reading, support the crank with a jack under the counterweights and check only one bearing at a time.

4. Reinstall the bearings and caps, then torque the bolts.

75 N·m (7.5 kg-m, 54 lb-ft)

NOTE: Do not rotate the crankshaft during inspection.

5. Remove the cap and bearings again, and measure the widest part of the plastigage.

Main Bearing-to-Journal Oil Clearance: Standard (New):

No. 1, 2:	0.021 — 0.045 mm (0.0008 — 0.0018 in)
Service Limit:	0.050 mm (0.0020 in)
No. 3	0.025 — 0.049 mm (0.0010 — 0.0019 in)
Service Limit:	0.055 mm (0.0022 in)
No. 4	0.013 — 0.037 mm (0.0005 — 0.0015 in)
Service Limit:	0.050 mm (0.0020 in)
No. 5	0.009 — 0.033 mm (0.0004 — 0.0013 in)
Service Limit:	0.040 mm (0.0016 in)

PLASTIGAGE STRIP

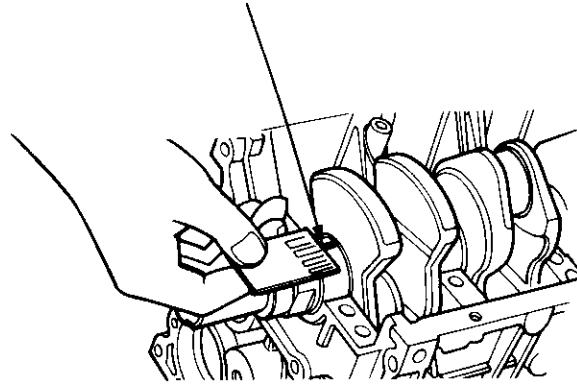

6. If the plastigage measures too wide or too narrow, (remove the engine if it's still in the car), remove the crankshaft, and remove the upper half of the bearing. Install a new, complete bearing with the same color code (select the color as shown on the next page), and recheck the clearance.

CAUTION: Do not file, shim, or scrape the bearings or the caps to adjust clearance.

7. If the plastigage shows the clearance is still incorrect, try the next larger or smaller bearing (the color listed above or below that one), and check again.

NOTE: If the proper clearance cannot be obtained by using the appropriate larger or smaller bearings, replace the crankshaft and start over.



Selection

CAUTION: If the codes are indecipherable because of an accumulation of dirt and dust, do not scrub them with a wire brush or scraper. Clean them only with solvent or detergent.

Crankshaft Bore Code Location (Numbers, Letters or Bars)

Numbers or Letters or Bars have been stamped on the end of the block as a code for the size of each of the 5 main journal bores.

Use them, and the numbers stamped on the crankshaft (codes for main journal size), to choose the correct bearings.

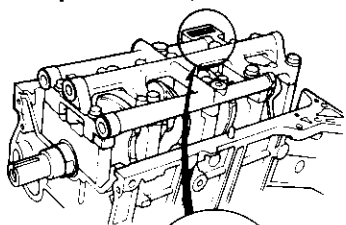

No. 1 JOURNAL
(PULLEY END)

No. 5 JOURNAL
(FLYWHEEL END)

Bearing Design

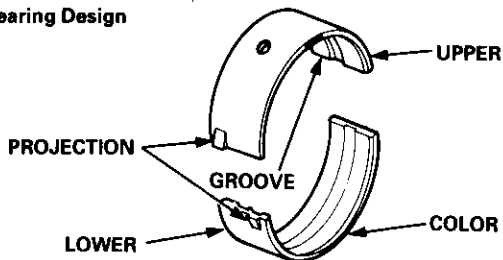

Bearing Identification

Color code is on the edge of the bearing.

1 or I
2 or II
3 or III
4 or IIII
5 or IIIII
6 or IIIII

Smaller
main
journal

Smaller
bearing
(Thicker)

→ Larger crank bore			
1 or A or I	2 or B or II	3 or C or III	4 or D or IIII

→ Smaller bearing (Thicker)			
Pink	Pink/ Yellow	Yellow	Yellow/ Green
Pink/ Yellow	Yellow	Yellow/ Green	Green
Yellow	Yellow/ Green	Green	Green/ Brown
Yellow/ Green	Green	Green/ Brown	Brown
Green	Green/ Brown	Brown	Brown/ Black
Green/ Brown	Brown	Brown/ Black	Black

NOTE: When using bearing halves of different colors, it does not matter which color is used in the top or bottom.

Main Journal Code Locations (Numbers or Bars)

H22A1 engine:

Main Journal Code Locations (Numbers or Bars)

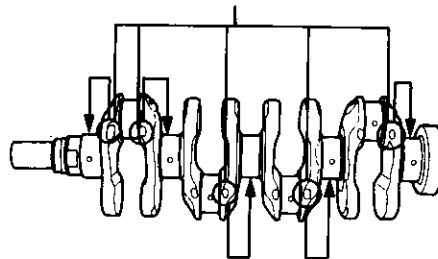

H23A1, F22A1 engines:

The Main Journal Codes are stamped in one of the following locations.

Main Journal Code Locations (Numbers or Bars)

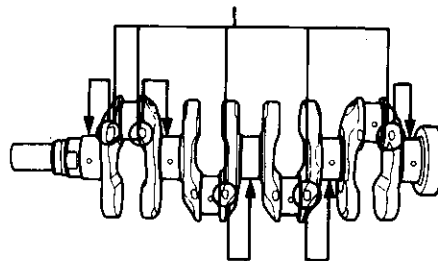

Main Journal Code Locations (Numbers or Bars)

No. 5 JOURNAL
(FLY WHEEL END)

No. 1 JOURNAL
(PULLEY END)

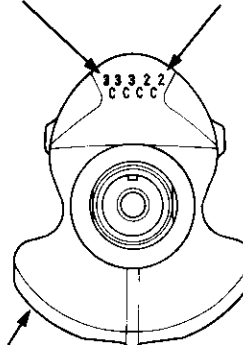

No. 1 CRANK WEB

Connecting Rod Bearings

Clearance

1. Remove the connecting rod cap and bearing half.
2. Clean the crankshaft rod journal and bearing half with a clean shop towel.
3. Place plastigage across the rod journal.
4. Reinstall the bearing half and cap, and torque the nuts to:

47 N-m (4.7 kg-m, 34 lb-ft)

NOTE: Do not rotate the crankshaft during inspection.

5. Remove the rod cap and bearing half and measure the widest part of the plastigage.

Connecting Rod Bearing-to-Journal Oil Clearance:

F22A1 engine:

Standard (New): 0.021 — 0.049 mm
(0.0008 — 0.0019 in)

Service Limit: 0.05 mm (0.002 in)

H23A1, H22A1 engines:

Standard (New): 0.027 — 0.055 mm
(0.0011 — 0.0022 in)

Service Limit: 0.06 mm (0.002 in)

6. If the plastigage measures too wide or too narrow, remove the upper half of the bearing, install a new, complete bearing with the same color code (select the color as shown on the next page), and recheck the clearance.

CAUTION: Do not file, shim, or scrape the bearings or the caps to adjust clearance.

7. If the plastigage shows the clearance is still incorrect, try the next larger or smaller bearing (the color listed above or below that one), and check clearance again.

NOTE: If the proper clearance cannot be obtained by using the appropriate larger or smaller bearings, replace the crankshaft and start over.

PLASTIGAGE STRIP

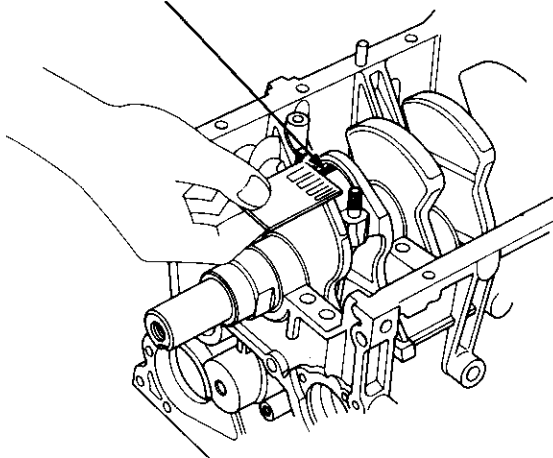



Selection

CAUTION: If the codes are indecipherable because of an accumulation of dirt and dust, do not scrub them with a wire brush or scraper. Clean them only with solvent or detergent.

Connecting Rod Journal Code Locations (Numbers or Bars)

Numbers or Bars have been stamped on the side of each connecting rod as a code for the size of the big end. Use it, and the letters or bars stamped on the crank (codes for rod journal size), to choose the correct bearings.

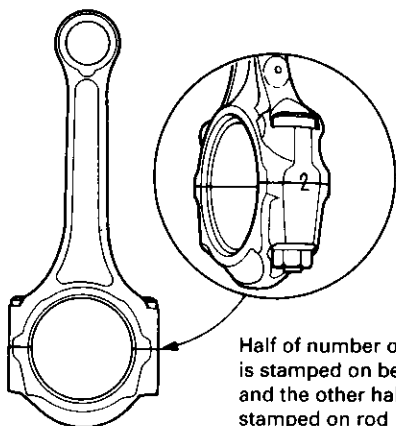

Half of number or bar is stamped on bearing cap and the other half is stamped on rod

Bearing Design

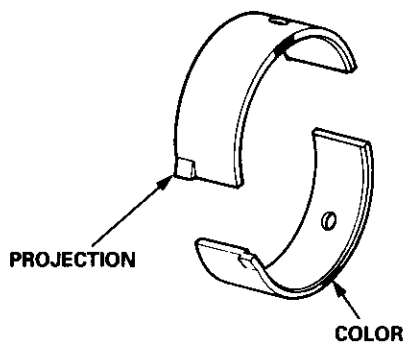

Bearing Identification

Color code is on the edge of the bearing.

A or I	Smaller rod journal
B or II	
C or III	
D or IIII	
	Smaller bearing (Thicker)

→ Larger big end bore

1 or I	2 or II	3 or III	4 or IIII
--------	---------	----------	-----------

→ Smaller bearing (Thicker)

Red	Pink	Yellow	Green
Pink	Yellow	Green	Brown
Yellow	Green	Brown	Black
Green	Brown	Black	Blue

Connecting Rod Journal Code Locations (Letters or Bars)

H22A1 engine:

Connecting Rod Journal Code Locations (Letters or Bars)

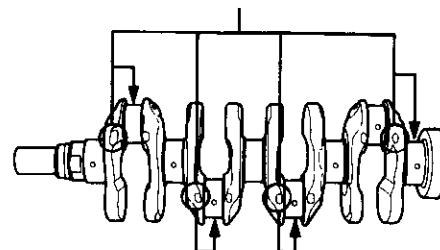

H23A1, F22A1 engines:

The Connecting Rod Journal Codes are stamped in one of the following locations.

Connecting Rod Journal Code Locations (Letters or Bars)

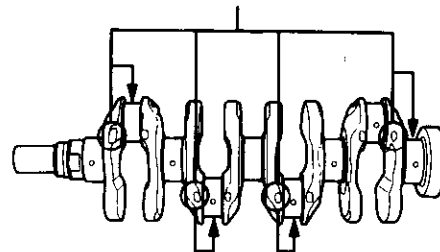

Connecting Rod Journal Code Locations (Letters or Bars)

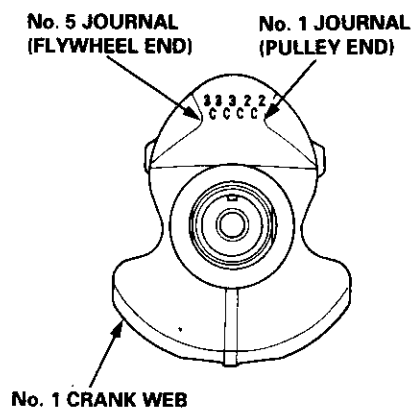

Crankshaft, Balancer Shafts and Pistons

Removal

1. Remove the right side cover.

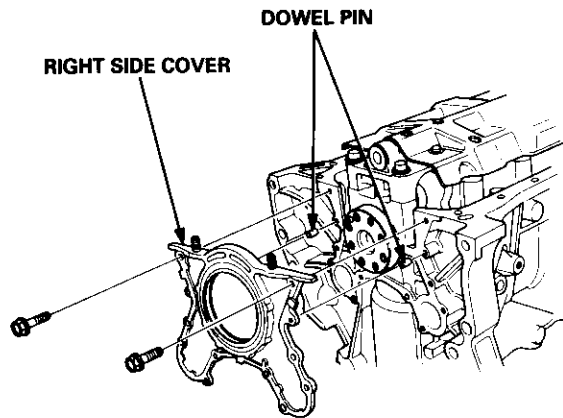

2. Remove the balancer gear case.

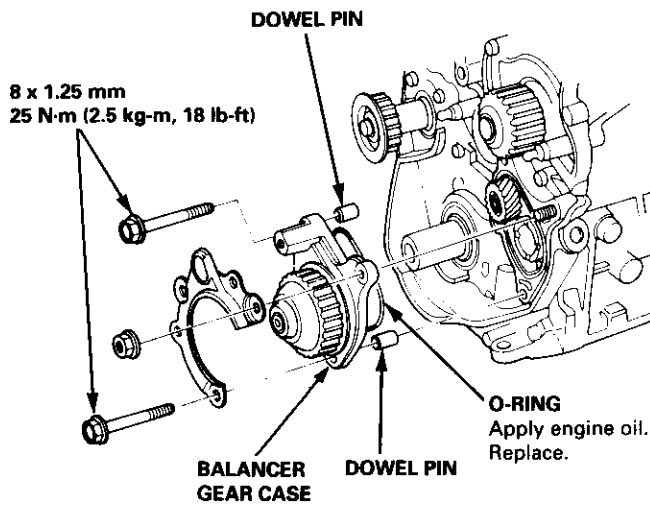

3. Remove the front balancer driven pulley as shown.

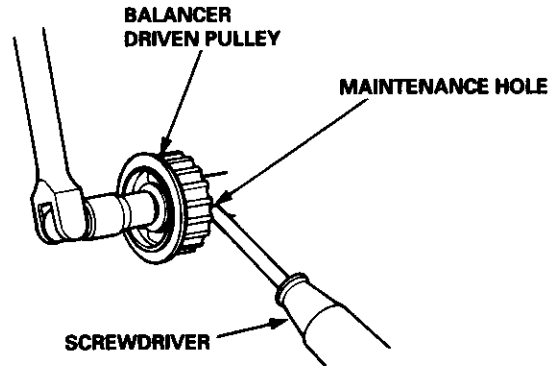

4. Align the bolt hole and the balancer shaft hole, then insert a 6 x 100 mm bolt to hold the rear balancer shaft.
5. Remove the bolt and the balancer driven gear.

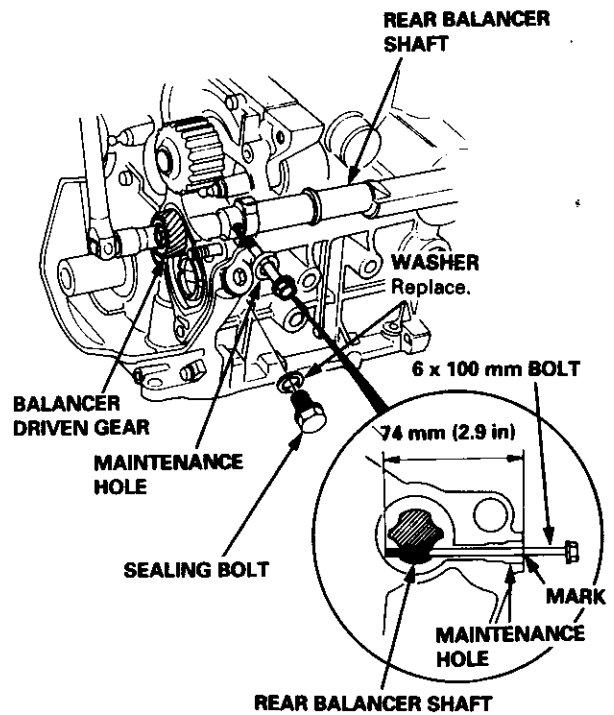



6. Remove the oil screen and the oil pump.

7. Remove the baffle plate.

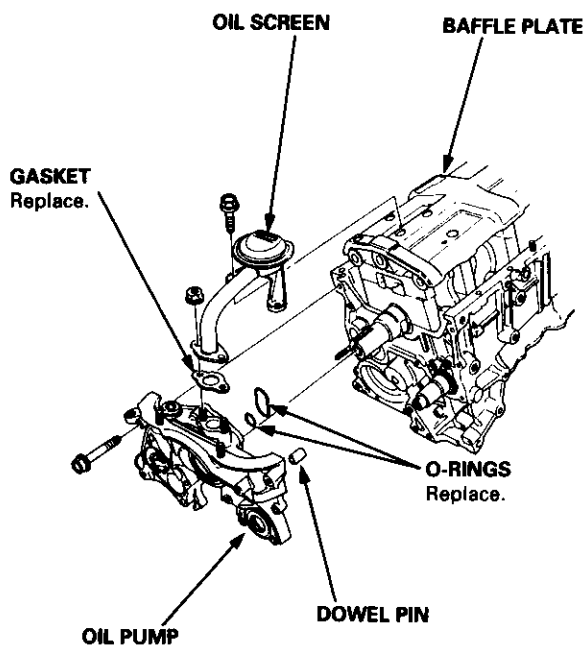

8. Remove the bolts and the bearing cap bridge, then remove the bearing caps.

CAUTION: To prevent warpage, unscrew the bolts in sequence 1/3 turn at a time; repeat the sequence until all bolts are loosened.

MAIN BEARING CAP BOLTS LOOSENING SEQUENCE

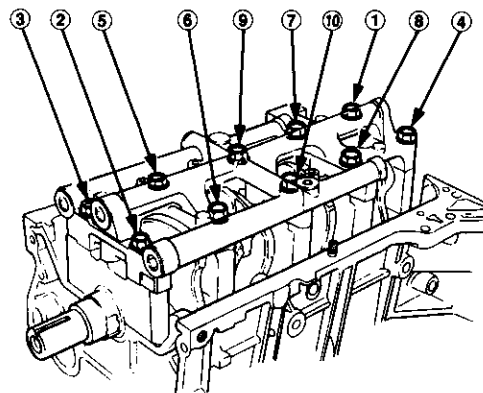

(cont'd)

Crankshaft, Balancer Shafts and Pistons

Removal (cont'd)

9. Turn the crankshaft so No. 2 and 3 crankpins are at the top.
10. Remove the rod caps/bearings and main caps/bearings. Keep all caps/bearings in order.
11. Lift the crankshaft out of the engine, being careful not to damage journals.

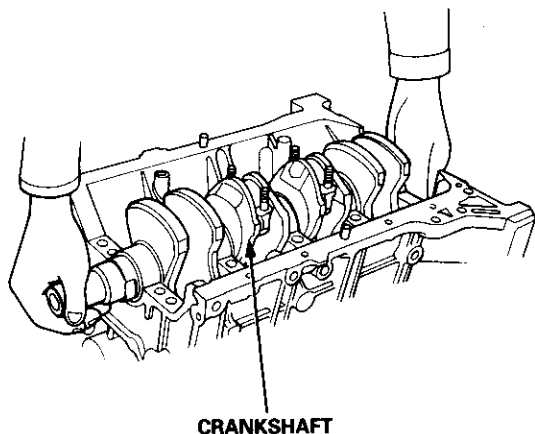

12. Remove the bolts and the retainer, then remove the front balancer shaft and the rear balancer shaft.

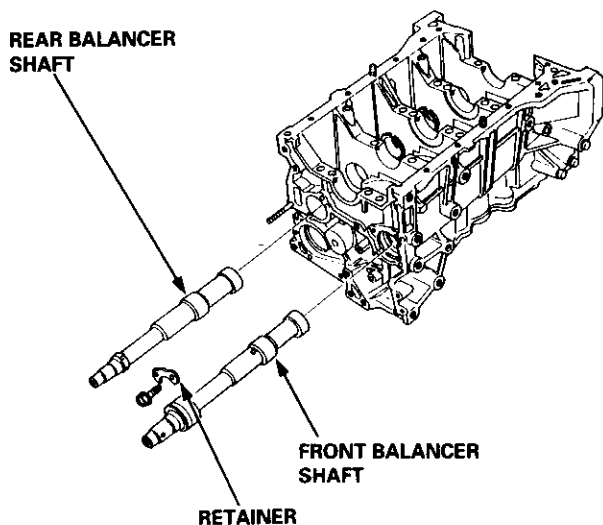

13. Remove the upper bearing halves from the connecting rods and set them aside with their respective caps.
14. Reinstall the main caps and bearings on the engine in proper order.

15. If you can feel a ridge of metal or hard carbon around the top of each cylinder, remove it with a ridge reamer. Follow the reamer manufacturer's instructions.

CAUTION: If the ridge is not removed, it may damage the pistons as they are pushed out.

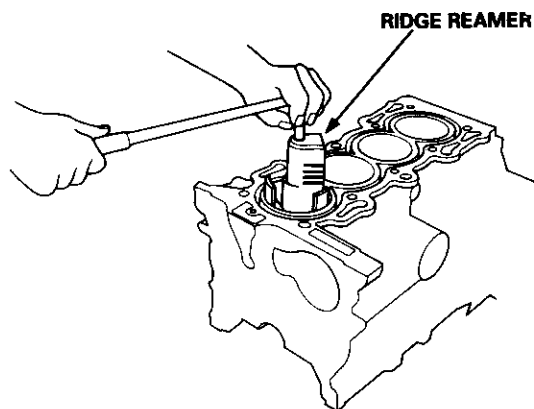

16. Use the wooden handle of a hammer to drive the pistons out.

CAUTION:

- Take care not to damage the contact surface of the metal gasket.
- When removing the piston/connecting rod take care not to hit the oil jet (H22A1 engine only).
- If the oil jet nozzle is damaged or deformed, replace the oil jet assembly (H22A1 engine only, page 8-8).

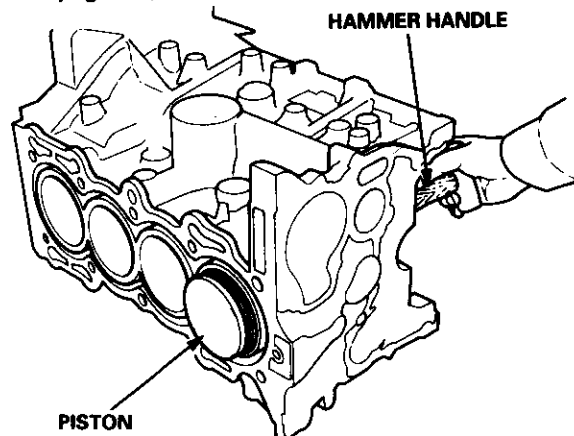

17. Reinstall the connecting rod bearings and caps after removing each piston/connecting rod assembly.
18. Mark each piston/connecting rod assembly with its cylinder number to avoid mixup on reassembly.

NOTE: The existing number on the connecting rod does not indicate its position in the engine, it indicates the rod bore size.



Crankshaft

Inspection

- Clean the crankshaft oil passages with pipe cleaners or a suitable brush.
- Check the keyway and threads.

Alignment

- Measure runout on all main journals to make sure the crank is not bent.
- The difference between measurements on each journal must not be more than the service limit.

Crankshaft Total Indicated Runout:

Standard (New): 0.03 mm (0.001 in)

Service Limit: 0.04 mm (0.002 in)

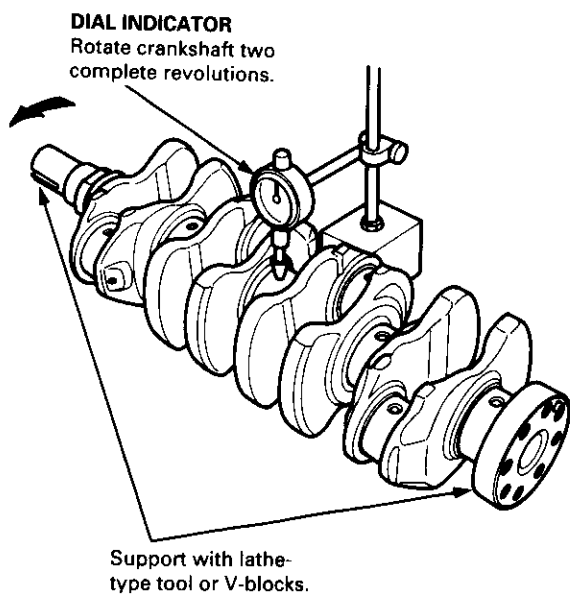

Out-of-Round and Taper

- Measure out-of-round at the middle of each rod and main journal in two places.
- The difference between measurements on each journal must not be more than the service limit.

Journal Out-of-Round:

Standard (New): 0.005 mm (0.0002 in)

Service Limit: 0.006 mm (0.0002 in)

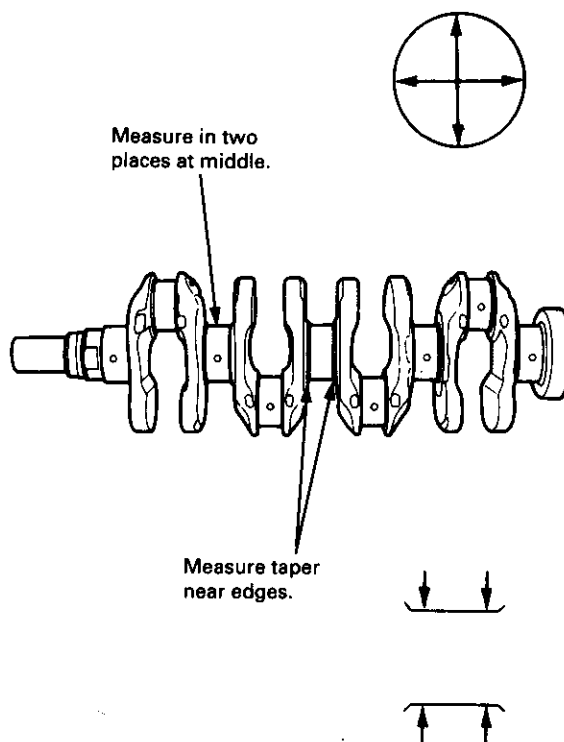

- Measure taper at the edge of each rod and main journal.
- The difference between measurements on each journal must not be more than the service limit.

Journal Taper:

Standard (New): 0.005 mm (0.0002 in) max.

Service Limit: 0.006 mm (0.0002 in)

Pistons

Inspection

1. Check the piston for distortion or cracks.

NOTE: If the cylinder is bored, an oversized piston must be used.

2. Measure the piston diameter at a point F22A1: 21 mm (0.8 in), H23A1, H22A1: 15 mm (0.6 in) from the bottom of the skirt.

NOTE: There are two standard-size pistons (No Letter (A) or B). The letter is stamped on the top of the piston. There letters are also stamped on the block as cylinder bore sizes.

Piston Diameter:

F22A1 engine:

Standard (New):

No Letter (A): 84.980 — 84.990 mm
(3.3457 — 3.3461 in)

B: 84.970 — 84.980 mm
(3.3453 — 3.3457 in)

Service Limit:

No Letter (A): 84.970 mm (3.3453 in)
B: 84.960 mm (3.3449 in)

H23A1, H22A1 engines:

Standard (New):

No Letter (A): 86.990 — 87.003 mm
(3.4248 — 3.4253 in)

B: 86.980 — 86.993 mm
(3.4244 — 3.4249 in)

Service Limit:

No Letter (A): 86.980 mm (3.4244 in)
B: 86.970 mm (3.4240 in)

F22A1 engine:
21 mm (0.8 in)

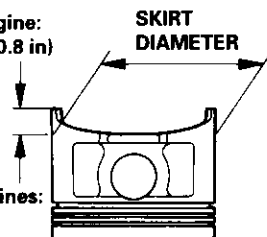

H23A1, H22A1 engines:
15 mm (0.6 in)

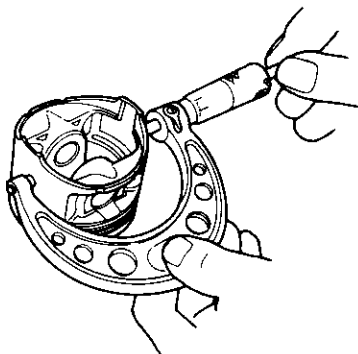

3. Calculate the difference between cylinder bore diameter on (page 7-17) and piston diameter.

Piston-to-Cylinder Clearance:

F22A1 engine:

Standard (New): 0.020 — 0.040 mm
(0.0008 — 0.0016 in)

Service Limit: 0.05 mm (0.002 in)

H23A1, H22A1 engines:

Standard (New): 0.007 — 0.030 mm
(0.0003 — 0.0012 in)

Service Limit: 0.04 mm (0.002 in)

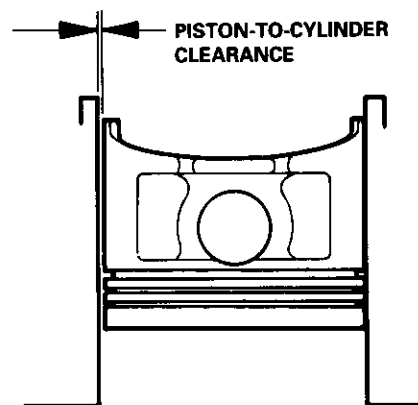

If the clearance is near or exceeds the service limit, inspect the piston and cylinder block for excessive wear.

Oversize Piston Diameter:

F22A1 engine:

0.25: 85.230 — 85.240 mm (3.3555 — 3.3559 in)
0.50: 85.480 — 85.490 mm (3.3653 — 3.3657 in)

H23A1, H22A1 engines:

0.25: 87.230 — 87.243 mm (3.4342 — 3.4348 in)

4. Check the piston pin-to-piston clearance. Coat the piston pin with engine oil. It should then be possible to push the piston pin into the piston hole with thumb pressure.

Piston Pin-to-Piston Clearance:

F22A1 engine:

Standard (New): 0.012 — 0.024 mm
(0.0005 — 0.0009 in)

H23A1, H22A1 engines:

Standard (New): 0.012 — 0.026 mm
(0.0005 — 0.0010 in)



Cylinder Block

Inspection

1. Measure wear and taper in direction X and Y at three levels in each cylinder as shown.

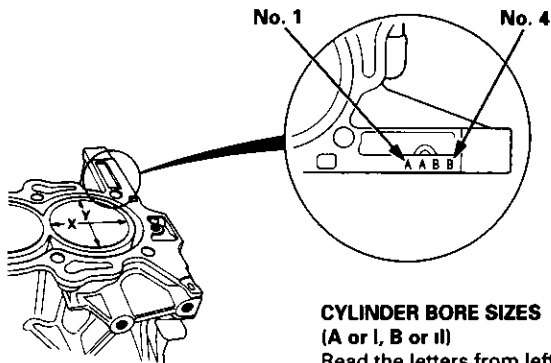
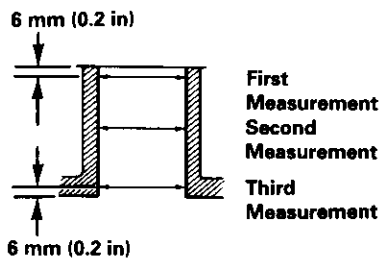

CYLINDER BORE SIZES
(A or I, B or II)
Read the letters from left-to-right
for No. 1 through No. 4 cylinders.

CYLINDER BORE GAUGE

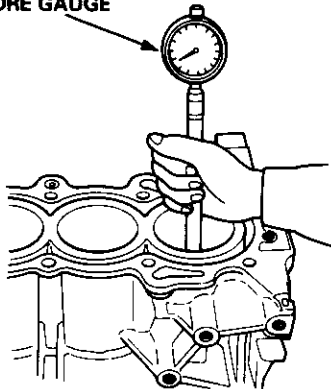

Cylinder Bore Size:

F22A1 engine:

Standard (New):

A or I: 85.010 — 85.020 mm (3.3468 — 3.3472 in)

B or II: 85.000 — 85.010 mm (3.3465 — 3.3468 in)

Service Limit: 85.070 mm (3.3492 in)

H23A1, H22A1 engines:

Standard (New):

A or I: 87.010 — 87.020 mm (3.4256 — 3.4260 in)

B or II: 87.000 — 87.010 mm (3.4252 — 3.4256 in)

Service Limit: 87.070 mm (3.4279 in)

Oversize:

F22A1 engine:

0.25: 85.250 — 85.260 mm (3.3563 — 3.3569 in)

0.50: 85.500 — 85.510 mm (3.3661 — 3.3665 in)

H23A1, H22A1 engines:

0.25: 87.260 mm (3.4354 in)

Bore Taper:

Limit: (Difference between first and third measurement) 0.05 mm (0.002 in)

- If measurements in any cylinder are beyond Oversize Bore Service Limit, replace the block.
- If the block is to be rebored, refer to Piston Clearance Inspection (page 7-16) after reboring.

NOTE: Scored or scratched cylinder bores must be honed.

F22A1 engine: 0.50 mm (0.020 in)

H23A1, H22A1 engines: 0.25 mm (0.010 in)

2. Check the top of the block for warpage. Measure along the edges and across the center as shown.

SURFACES TO BE MEASURED

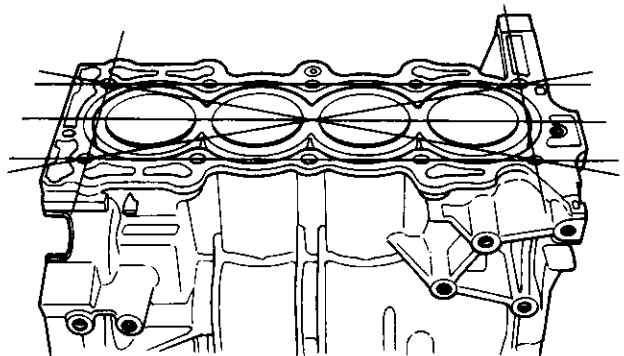

Engine Block Warpage:

Standard (New): below 0.07 mm (0.003 in)

Service Limit: 0.10 mm (0.004 in)

PRECISION STRAIGHT EDGE

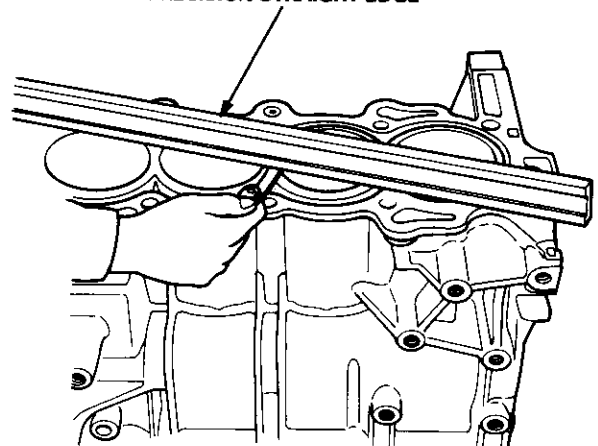

Cylinder Block

Bore Honing (H23A1, H22A1 engines)

CAUTION: This cylinder liner uses FRM (Fiber Reinforced Metal). Hone only as directed below.

1. Measure cylinder bores as shown on page 7-16. If the block is to be reused, hone the cylinders and remeasure the bores.
2. To hone cylinder bores:
 - Use only a rigid hone.
 - Honing stone: GC — 600 — J or finer stone (for nonferrous metals)
 - Pressure: 200 — 300 kPa (2—3 kg-cm², 28 — 43 psi)
 - Honing rpm: 45 — 50 rpm
 - Honing thickness: Less than 0.02 mm (0.0008 in) Do not hone more than 20 cycles
 - Honing lubricant: Oil type
 - Roughness of finished surfaces: $\nabla\nabla\nabla$ or 1.2S
 - Honing pattern: 60 degree cross-hatch

CAUTION: Clean the honing stone every 5 cycles.

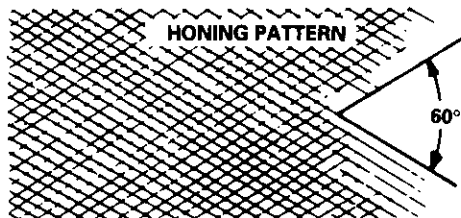

3. When honing is complete, thoroughly clean the cylinder block of all metal particles. Wash the cylinder bores with hot soapy water, then dry and oil immediately to prevent rusting.

NOTE: Never use solvent, it will only redistribute the grit on the cylinder walls.

4. If scoring or scratches are still present in cylinder bores after honing to service limit, rebore the cylinder block.

NOTE: Some light vertical scoring and scratching is acceptable if it is not deep enough to catch your fingernail and does not run the full length of the bore.

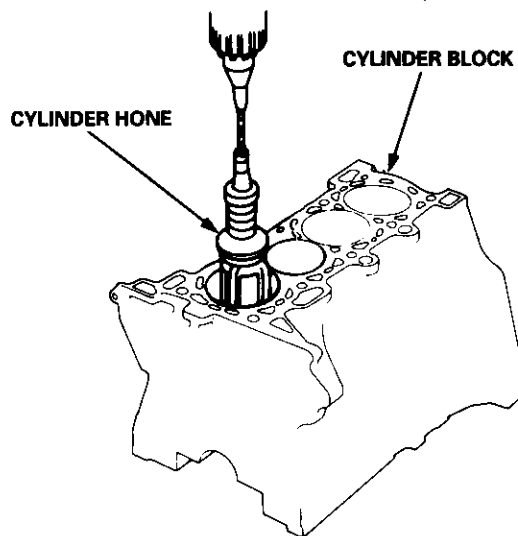



Piston Pins

Bore Honing (F22A1 engine)

1. Measure cylinder bores as shown on page 7-16. If the block is to be reused, hone the cylinders and remeasure the bores.
2. Hone cylinder bores with honing oil and a fine (400 grit) stone in a 60 degree cross-hatch pattern.

NOTE:

- Use only a rigid hone with 400 grit or finer stone such as Sunnen, Ammco, or equivalent.
- Do not use stones that are worn or broken.

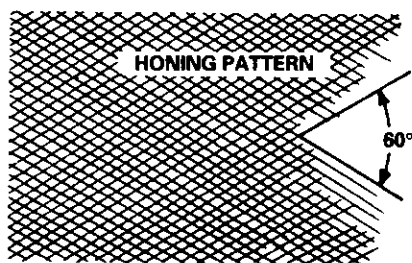

3. When honing is complete, thoroughly clean the engine block of all metal particles. Wash the cylinder bores with hot soapy water, then dry and oil immediately to prevent rusting.

NOTE: Never use solvent, it will only redistribute the grit on the cylinder walls.

4. If scoring or scratches are still present in cylinder bores after honing to the service limit, rebore the cylinder block.

NOTE: Some light vertical scoring and scratching is acceptable if it is not deep enough to catch your fingernail and does not run the full length of the bore.

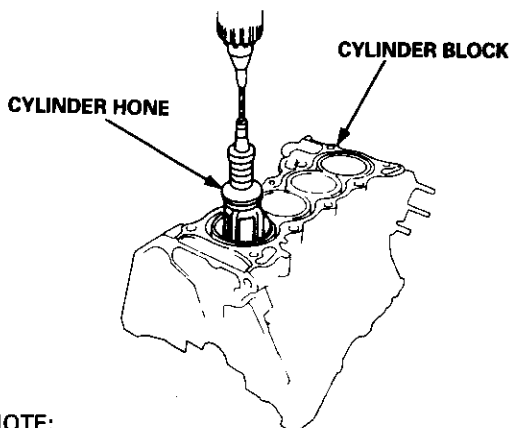

NOTE:

- After honing, clean the cylinder thoroughly with soapy water.
- Only a scored or scratched cylinder bore must be honed.

Removal

1. Assemble the Piston Pin Tools as shown.

PISTON BASE HEAD
07HAF — PL20102

PISTON PIN BASE INSERT
07GAF — PH60300

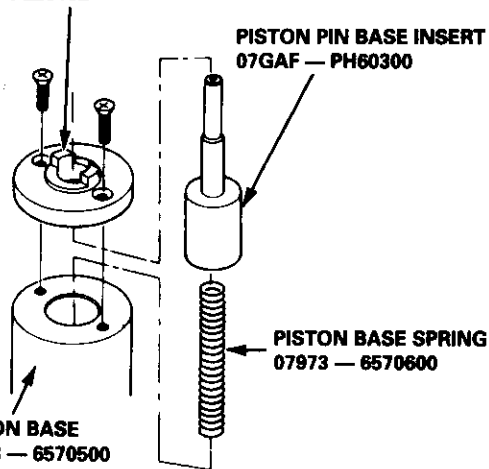

2. Adjust the length A of the piston pin driver.
A: 51.5 mm (2.03 in)

PISTON PIN DRIVER HEAD
07973 — PE00320

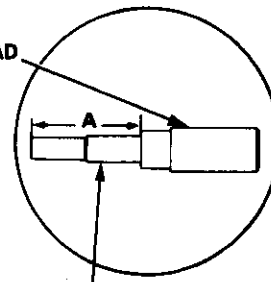

PISTON PIN DRIVER SHAFT
07973 — PE00310

PILOT COLLAR
07GAF — PH70100

Embossed mark facing up.

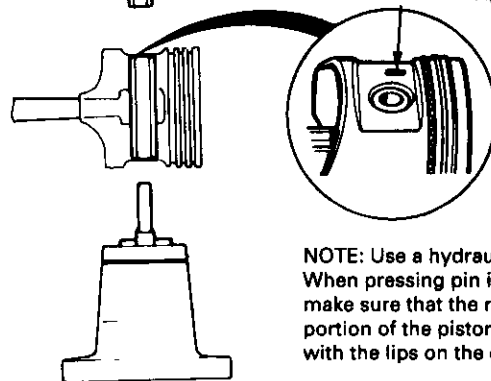

3. Place the piston on the piston base and press the pin out with a hydraulic press.

Connecting Rods

Selection

Each rod falls into one of four tolerance ranges (from 0 to 0.024 mm (0.0009 in), in 0.006 mm (0.0002 in) increments) depending on the size of its big end bore. It's then stamped with a number or bar (1, 2, 3, or 4/I, II, III, or IIII) indicating the range. You may find any combination of 1, 2, 3, or 4/I, II, III, or IIII in any engine.

Normal Bore Size: 51.0 mm (2.01 in)

NOTE:

- Reference numbers or bars are for big end bore size and do not indicate the position of the rod in the engine.
- Inspect connecting rod for cracks and heat damage.

CONNECTING ROD BORE REFERENCE NUMBER or BAR
Half of number is stamped on bearing cap, the other half on connecting rod.

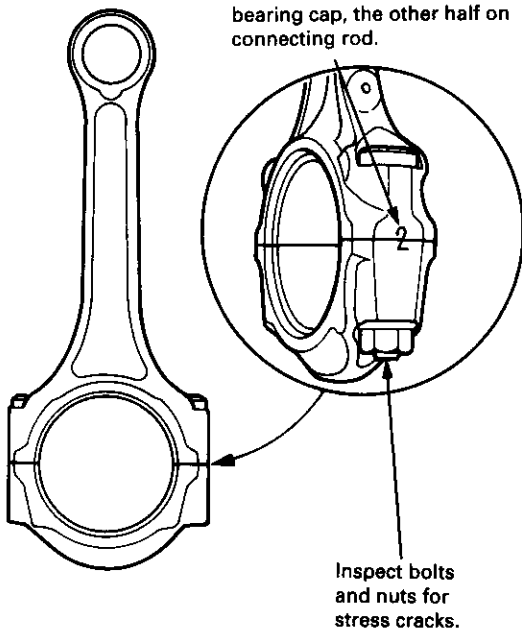

Piston Pins

Installation

1. Use a hydraulic press for installation.
 - When pressing the pin, in or out, be sure to position the recessed flat on the piston against the lugs on the base attachment.

The arrow must face the timing belt side of the engine.

The mark must face the timing belt side of the engine.

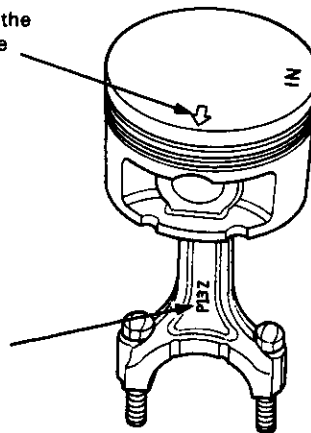

2. Adjust the length B of the piston pin driver.

B: 51.5 mm (2.03 in)

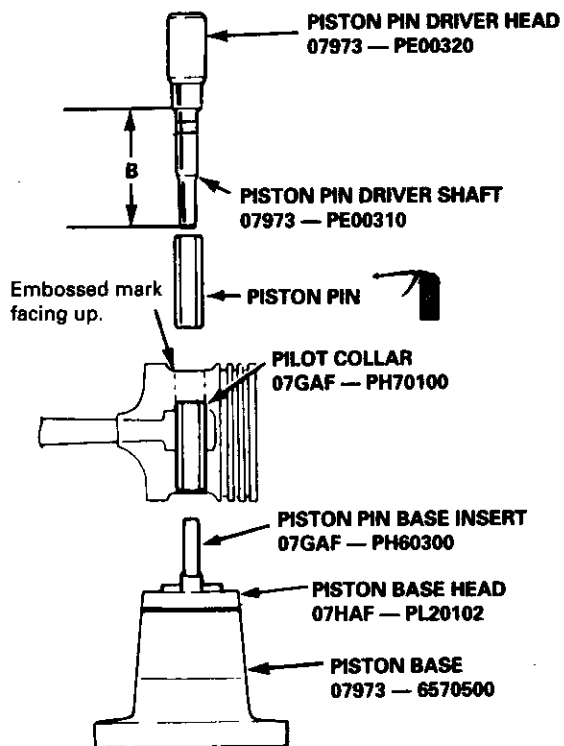

NOTE: Install the assembled piston and rod with the oil hole facing the intake manifold (Except H22A1 engine).



Piston Pins

Inspection

1. Measure the diameter of the piston pin.

Piston Pin Diameter:

Standard (New): 21.994 — 22.000 mm
(0.8659 — 0.8661 in)

Oversize: 21.997 — 22.003 mm
(0.8660 — 0.8663 in)

NOTE: All replacement piston pins are oversize.

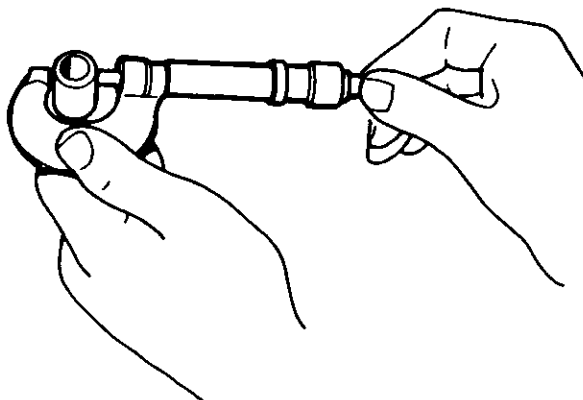

2. Zero the dial indicator to the piston pin diameter.

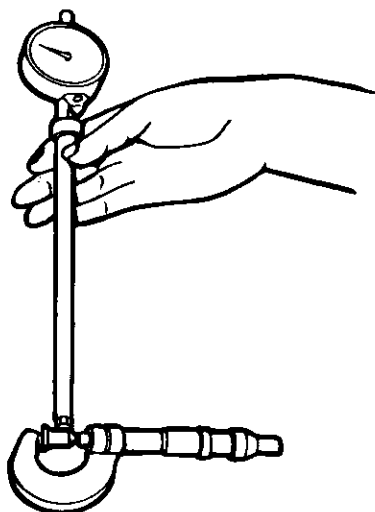

3. Measure the piston pin-to-piston clearance.

NOTE: Check the piston for distortion or cracks.

If the piston pin clearance is greater than F22A1 engine: 0.024 mm (0.0009 in) H23A1, H22A1 engines: 0.026 mm (0.0010 in), remeasure using an oversize piston pin.

Piston Pin-to-Piston Clearance:

F22A1 engine:

Standard (New): 0.012 — 0.024 mm
(0.0005 — 0.0009 in)

H23A1, H22A1 engines:

Standard (New): 0.012 — 0.026 mm
(0.0005 — 0.0010 in)

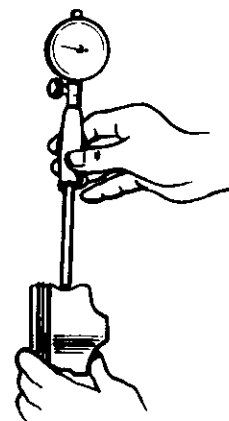

4. Check the difference between piston pin diameter and connecting rod small end diameter.

Piston pin-to Connecting Rod Interference:

Standard (New): 0.013 — 0.032 mm
(0.0005 — 0.0013 in)

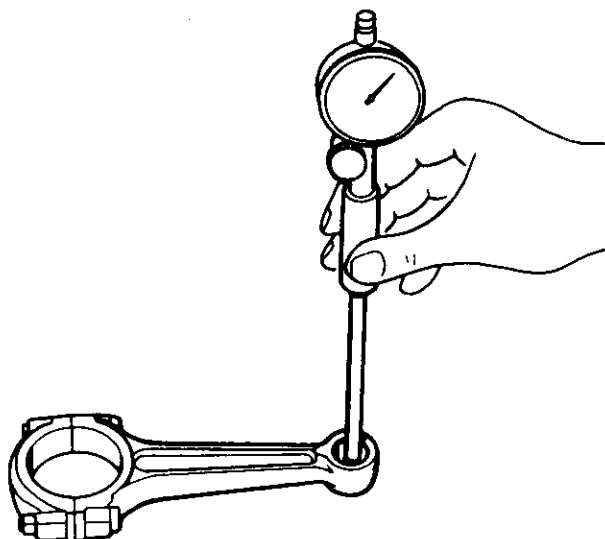

Piston Rings

End Gap

1. Using a piston, push a new ring into the cylinder bore 15 — 20 mm (0.6 — 0.8 in) from the bottom.
2. Measure the piston ring end-gap with a feeler gauge:
 - If the gap is too small, check to see if you have the proper rings for your engine.
 - If the gap is too large, recheck the cylinder bore diameter against the wear limits on page 7-17. If the bore is over the service limit, the cylinder block must be rebored.

Piston Ring End-Gap:

F22A1 engine:

Top Ring

Standard (New): 0.20 — 0.35 mm
(0.008 — 0.014 in)

Service Limit: 0.60 mm (0.024 in)

Second Ring

Standard (New): 0.40 — 0.55 mm
(0.016 — 0.022 in)

Service Limit: 0.70 mm (0.028 in)

Oil Ring

Standard (New): 0.20 — 0.70 mm
(0.008 — 0.028 in)

Service Limit: 0.80 mm (0.031 in)

H23A1, H22A1 engines:

Top Ring

Standard (New): 0.25 — 0.35 mm
(0.010 — 0.014 in)

Service Limit: 0.60 mm (0.024 in)

Second Ring

Standard (New): 0.60 — 0.75 mm
(0.024 — 0.030 in)

Service Limit: 0.90 mm (0.035 in)

Oil Ring

Standard (New):

TEIKOKU PISTON RING manufacture:

0.20 — 0.50 mm (0.008 — 0.020 in)

RIKEN manufacture:

0.20 — 0.70 mm (0.008 — 0.028 in)

Service Limit:

TEIKOKU PISTON RING manufacture:

0.60 mm (0.024 in)

RIKEN manufacture:

0.80 mm (0.031 in)

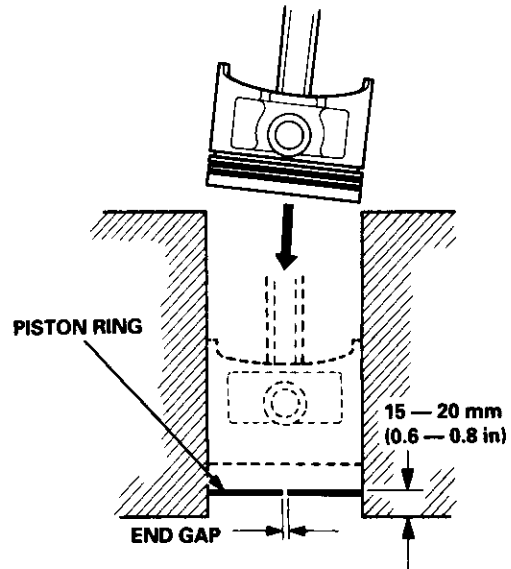

Oversize:

F22A1 engine:

0.25: 85.25 mm (3.356 in)

0.50: 85.50 mm (3.366 in)

H23A1, H22A1 engines:

0.25: 87.25 mm (3.435 in)



Replacement

1. Using a ring expander, remove the old piston rings.
2. Clean all ring grooves thoroughly.

NOTE:

- Use a squared-off broken ring or ring groove cleaner with blade to fit piston grooves.
- Top and 2nd ring grooves are 1.2 mm (0.05 in) wide and the oil ring groove is 2.8 mm (0.11 in) wide.
- File down blade if necessary.

CAUTION: Do not use a wire brush to clean the ring grooves, or cut ring grooves deeper with cleaning tools.

NOTE: If the piston is to be separated from the connecting rod, do not install new rings yet.

3. Install new rings in the proper sequence and position (page 7-24).

NOTE: Do not use old piston rings.

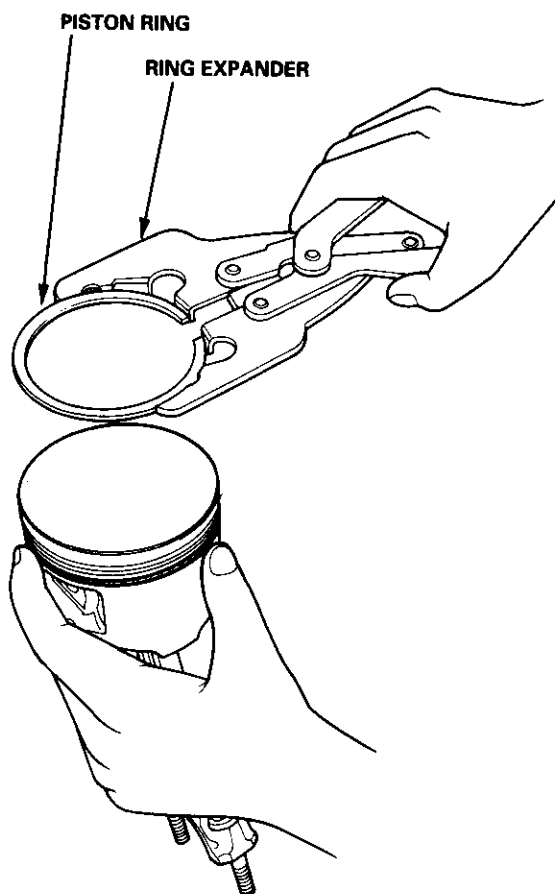

Ring-to-Groove Clearance

After installing a new set of rings, measure the ring-to-groove clearances:

Top Ring Clearance

Standard (New): 0.035 — 0.060 mm
(0.0014 — 0.0024 in)

Service Limit: 0.13 mm (0.005 in)

Second Ring Clearance

Standard (New): 0.030 — 0.055 mm
(0.0012 — 0.0022 in)

Service Limit: 0.13 mm (0.005 in)

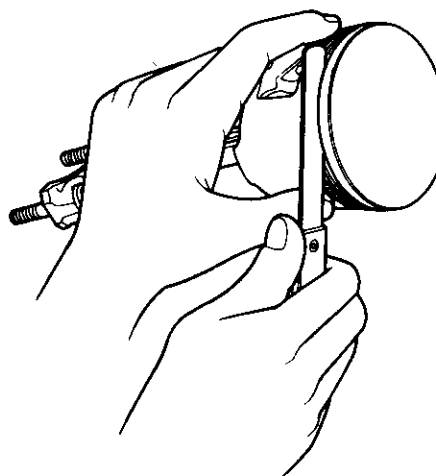

Piston Rings

Alignment

1. Install the rings as shown.

Identify top and second rings by the chamfer on the edge. Make sure they are in their proper grooves on the piston.

NOTE: The manufacturing marks must be facing upward.

F22A1 engine:

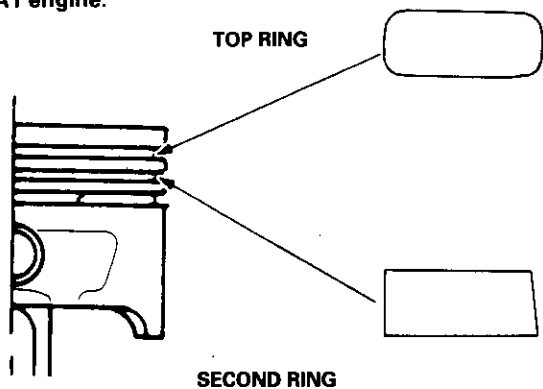

H23A1, H22A1 engines:

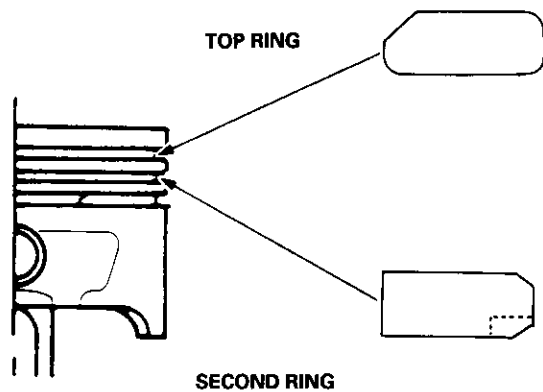

2. Rotate the rings in their grooves to make sure they do not bind.

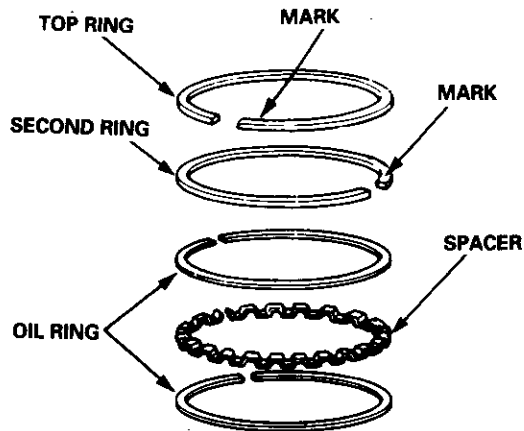

3. Position the ring end gaps as shown:

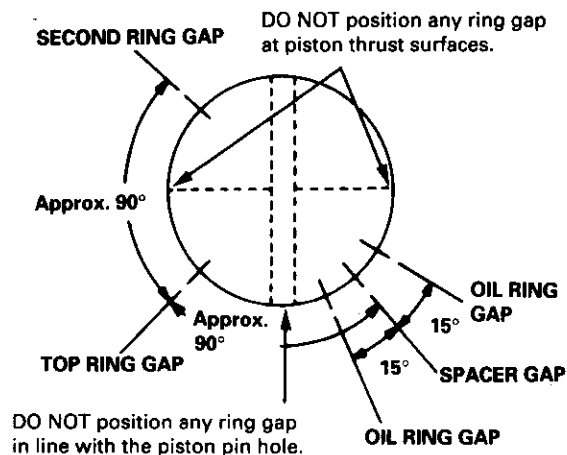

Crankshaft Oil Seal

Installation

 The seal surface on the block should be dry. Apply a light coat of oil to the crankshaft and to the lip of the seal.

1. Drive in crankshaft oil seal against right side cover.

NOTE: Drive the crankshaft oil seal in squarely.

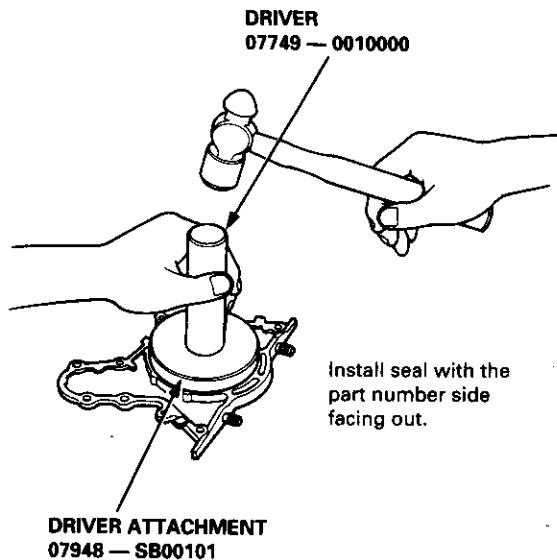

2. Confirm that the clearance is equal all the way around with a feeler gauge.

Clearance: 0.5 — 0.8 mm (0.02 — 0.03 in)

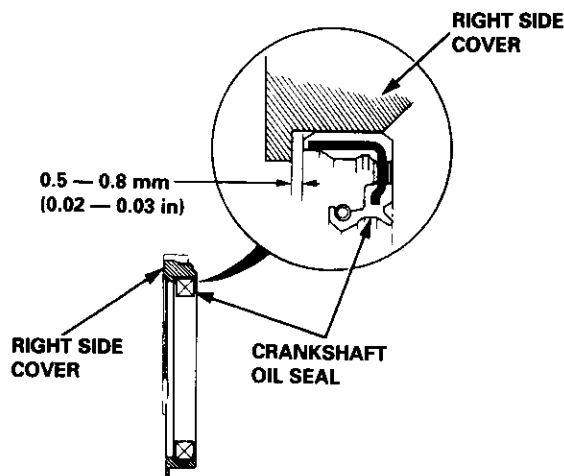

NOTE: Refer to pages 7-30 and 8-11 for installation of the oil pump side crankshaft oil seal.

Pistons

Installation

 Before installing the piston, apply a coat of engine oil to the ring grooves and cylinder bores.

1. If the crankshaft is already installed:
 - Set the crankshaft to BDC for each cylinder.
 - Remove the connecting rod caps and slip short sections of rubber hose over the threaded ends of the connecting rod bolts.
 - Install the ring compressor, check that the bearing is securely in place, then position the piston in the cylinder and tap it in using the wooden handle of a hammer.
 - Stop after the ring compressor pops free and check the connecting rod-to-crank journal alignment before pushing piston into place.
 - Install the rod caps with bearings, and torque the nuts to:
47 N·m (4.7 kg·m, 34 lb·ft)
2. If the crankshaft is not installed:
 - Remove the rod caps and bearings, install the ring compressor, then position the piston in the cylinder and tap it in using the wooden handle of a hammer.
 - Position all pistons at top dead center.

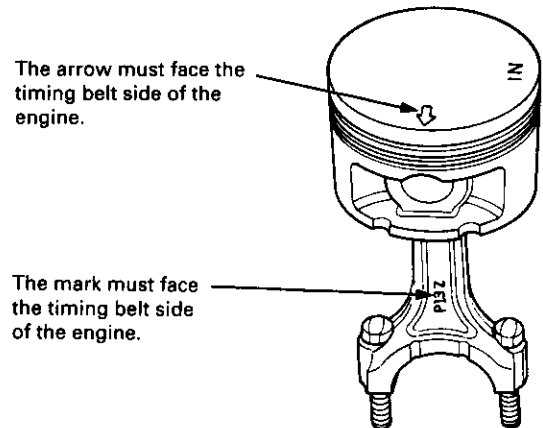

NOTE: Maintain downward force on the ring compressor to prevent rings from expanding before entering the cylinder bore.

Use the wooden handle of a hammer to push, or tap the piston into the cylinder bore.

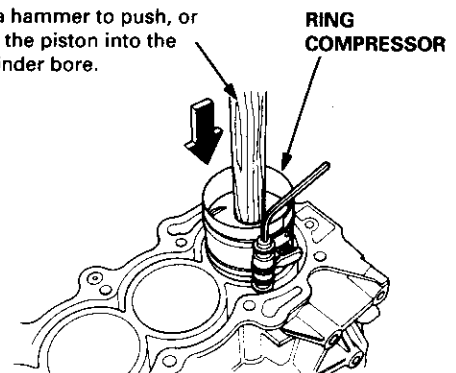

Crankshaft and Balancer Shafts

Installation

 Before installing the crankshaft, apply a coat of engine oil to the main bearings, rod bearings and balancer shaft bearings.

1. Insert bearing halves in the cylinder block and connecting rods.
2. Hold the crankshaft so rod journals for cylinders No. 2 and No. 3 are straight up.
3. Lower the crankshaft into the block, seating the rod journals into connecting rods No. 1 and No. 4. Install the rod caps and nuts finger tight.

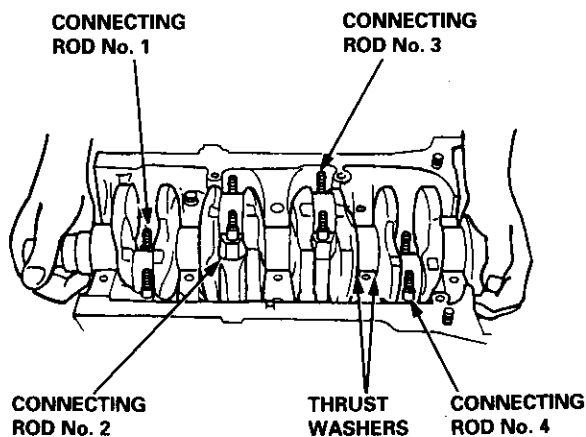

4. Rotate the crankshaft clockwise, seat journals into connecting rods No. 2 and No. 3, and install the rod caps and nuts finger tight.

NOTE: Install caps so the bearing recess is on the same side as the recess in the rod.

5. Check rod bearing clearance with plastigage (page 7-10), then torque the capnuts.
47 N-m (4.7 kg-m, 34 lb-ft)

NOTE: Reference numbers on connecting rod are for big-end bore tolerance and do not indicate the position of piston in the engine.

6. Install the thrust washers, main bearing caps and bearing cap bridge.
Check clearance with plastigage (page 7-8), then tighten the bearing cap bolts in 2 steps.
In the first step tighten all bolts in sequence, to about 30 N-m (3.0 kg-m, 22 lb-ft); in the final step tighten in same sequence, to 75 N-m (7.5 kg-m, 54 lb-ft).

NOTE: Coat the bolt threads with engine oil.

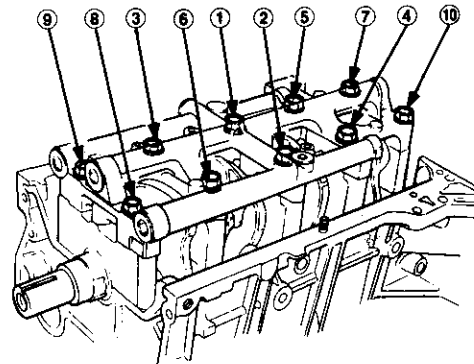

CAUTION: Whenever any crankshaft or connecting rod bearing is replaced, it is necessary after reassembly to run the engine at idling speed until it reaches normal operating temperature, then continue to run it for approximately 15 minutes.

7. Insert the balancer shafts into the block, then install the retainer to the front balancer shaft and block.

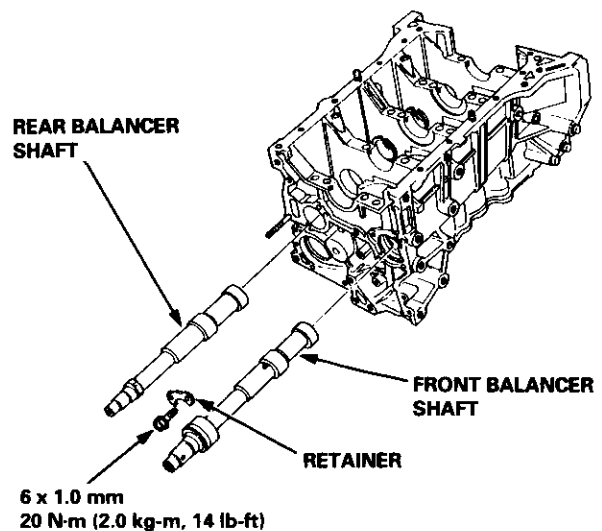



NOTE:

- Use liquid gasket, part No. 08718 — 0001.
- Check that the mating surfaces are clean and dry before applying liquid gasket.
- Apply liquid gasket evenly, being careful to cover all the mating surface.
- To prevent leakage of oil, apply liquid gasket to the inner threads of the bolt holes.
- Do not install the parts if 20 minutes or more have elapsed since applying the liquid gasket. Instead reapply liquid gasket after removing the old residue.
- After assembly, wait at least 30 minutes before filling the engine with oil.

8. Apply liquid gasket to the block mating surface of the right side cover, then install it on the cylinder block.

RIGHT SIDE COVER:

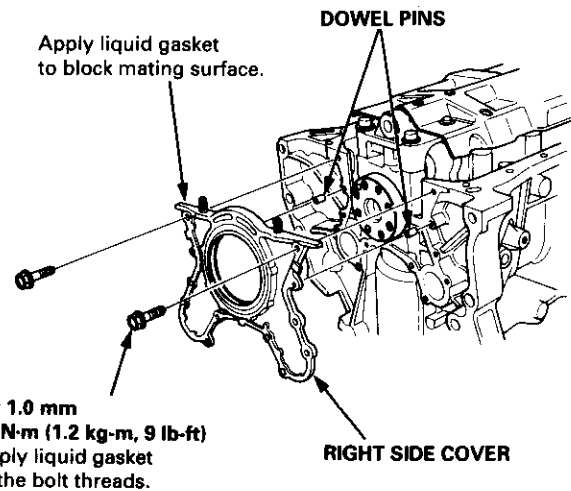
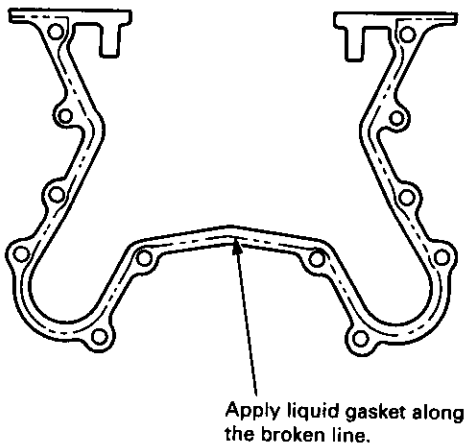

9. Apply liquid gasket to the oil pump mating surface of the block, then install the oil pump on the cylinder block.

- Apply grease to the lips of the oil seals. Then, install the oil pump while aligning the inner rotor with the crankshaft. When the pump is in place, clean any excess grease off the crankshaft and the balancer shaft, then check that the oil seal lips are not distorted.

OIL PUMP:

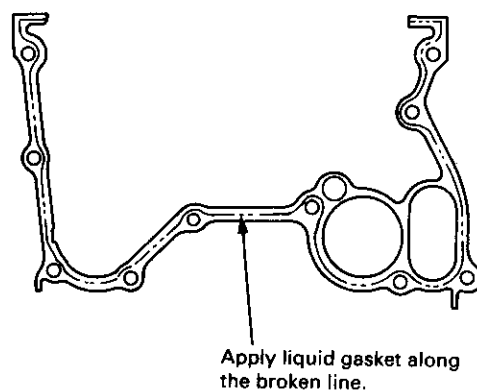

(cont'd)

Crankshaft and Balancer Shafts

Installation (cont'd)

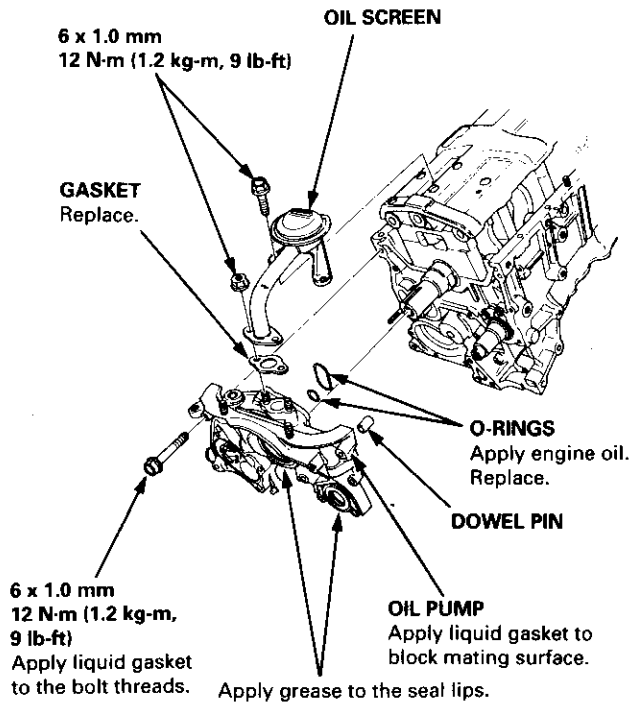

10. Install the baffle plate, then install the oil screen.

11. Apply molybdenum disulfide to the thrust surfaces of the balancer gears as shown, before installing the balancer driven gear and the balancer gear case.

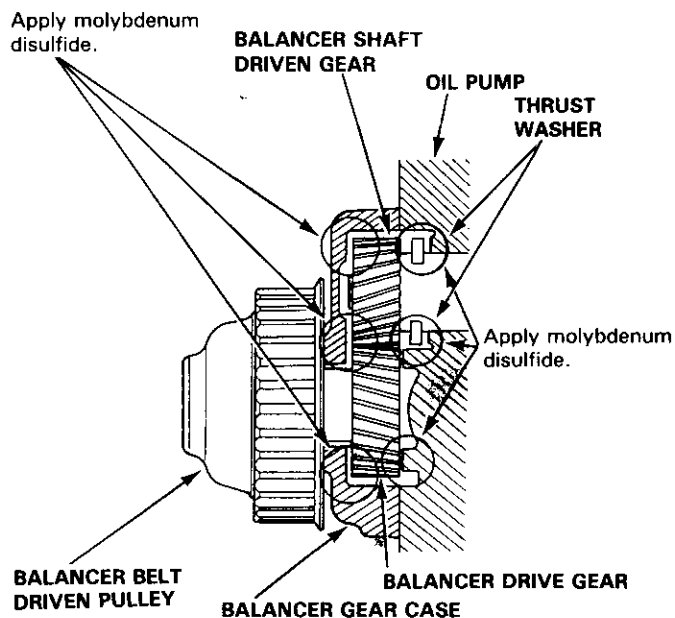

12. Hold the rear balancer shaft with a 6 x 100 mm bolt, then install the balancer driven gear.

REAR BALANCER SHAFT:

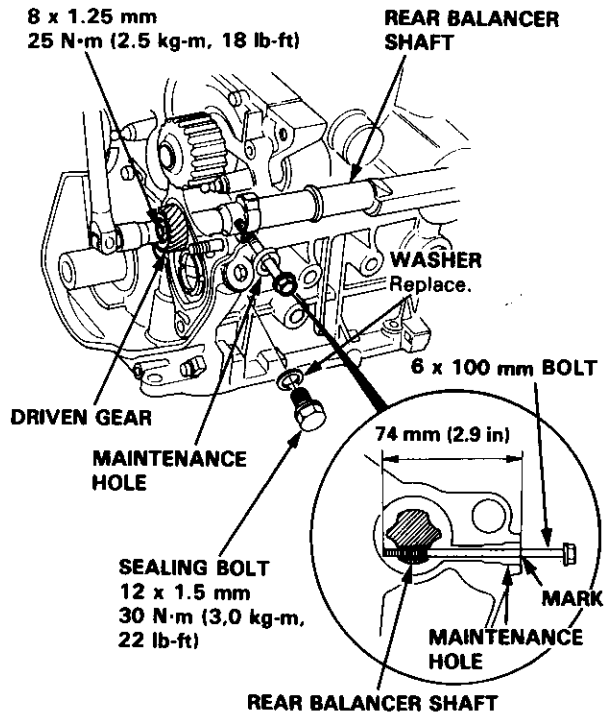

13. Hold the front balancer shaft with a screwdriver, then install the timing balancer belt driven pulley.

FRONT BALANCER SHAFT:

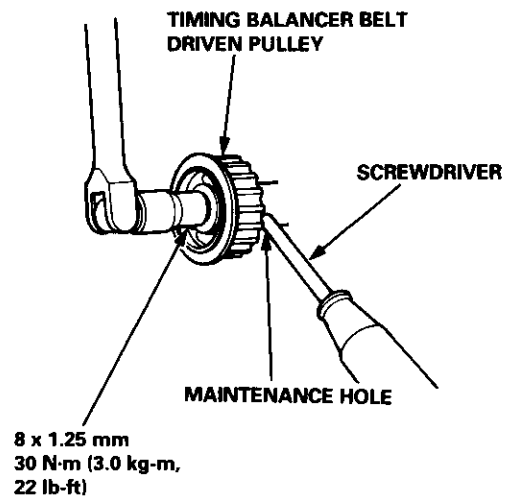



14. Install the balancer gear case to the oil pump.

NOTE: Align the groove on the pulley edge to the pointer on the gear case while holding the rear balancer with 6 x 100 mm bolt, then install the gear case.

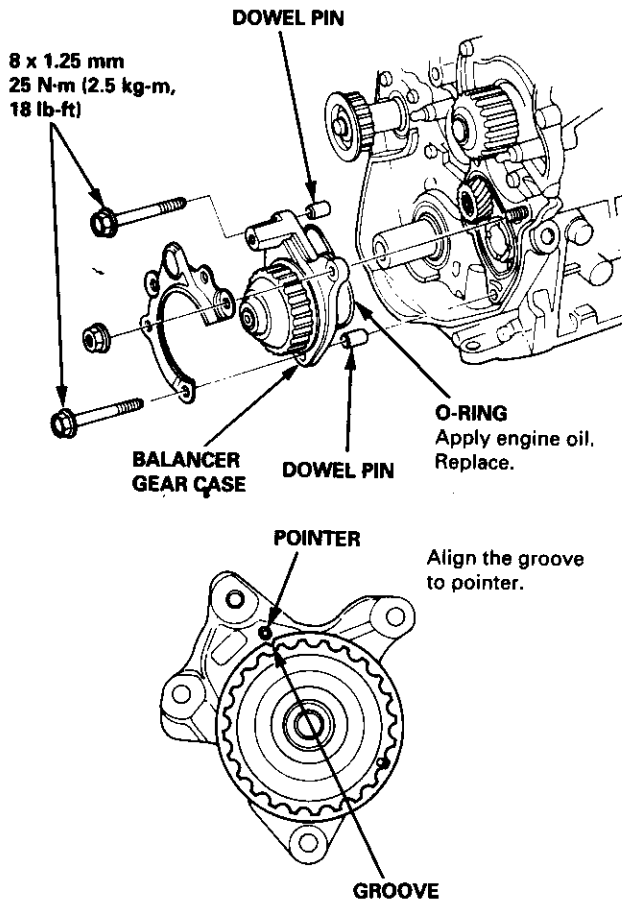

15. Check alignment of pointers after installing the gear case.

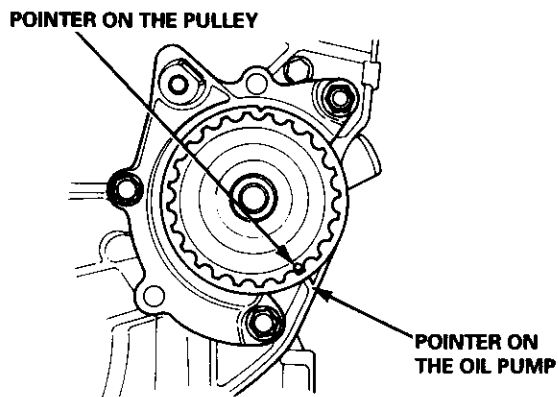

16. Install the oil pan.

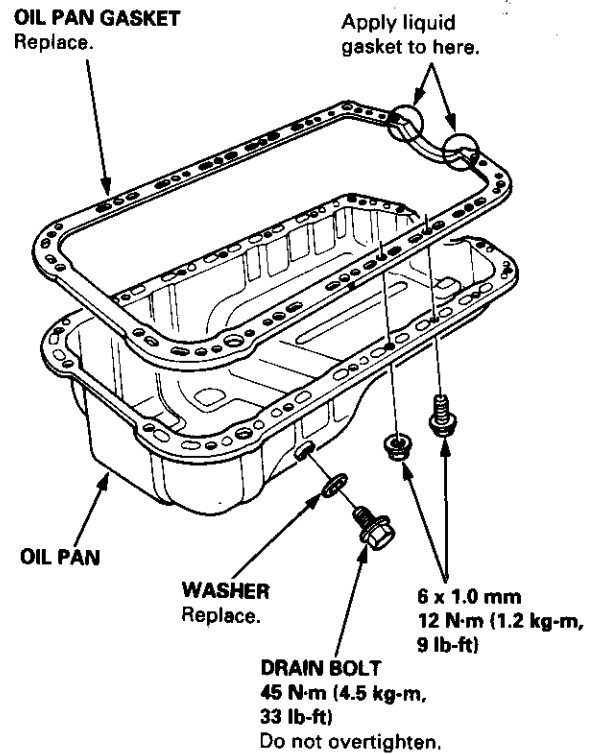

17. Tighten the bolts and nuts as shown below.

Torque: 12 N-m (1.2 kg-m, 9 lb-ft)

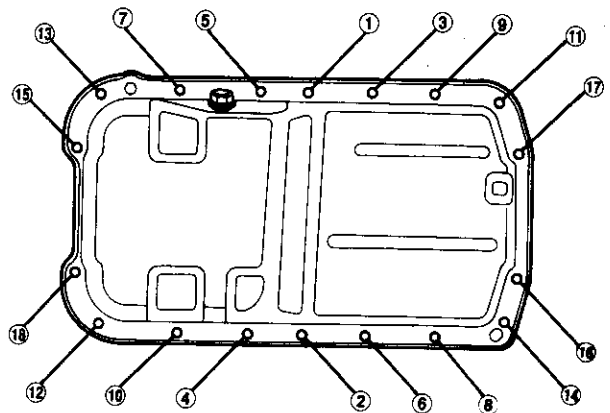

NOTE: Tighten the bolts and nuts in two steps and torque them in a criss-cross pattern.

Crankshaft and Balancer Shaft Oil Seals

Installation (engine removal not required)

NOTE: The crankshaft and front balancer shaft oil seal housing surface should be dry.

Apply a light coat of grease to the crankshaft, the balancer shaft and to the lips of the seals.

1. Using the special tool, drive in the crankshaft oil seal until the driver bottoms against the oil pump. When the seal is in place, clean any excess grease off the crankshaft and check that the oil seal lip is not distorted.

**SEAL DRIVER
07LAD — PT3010A**
Install seal with the
part number side
facing out.

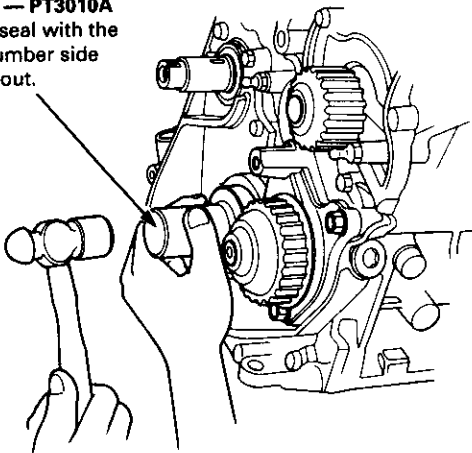

2. Using the special tool, drive in the front balancer shaft oil seal until the driver bottoms against the oil pump. When the seal is in place, clean any excess grease off the balancer shaft and check that the oil seal lip is not distorted.

**HUB ASSEMBLY GUIDE
ATTACHMENT
07GAF — SE00200**

**ATTACHMENT,
30 mm I.D.
07746 — 0030300**

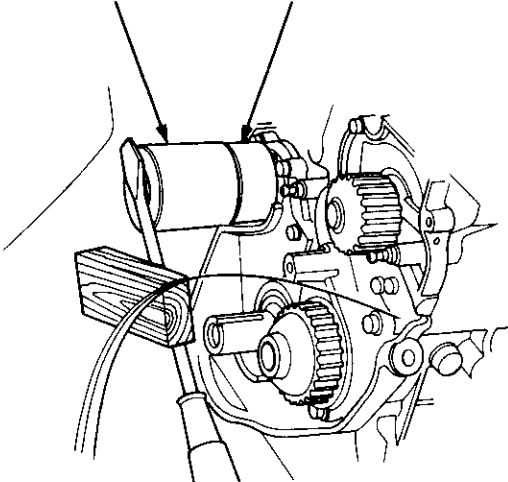

3. Using the special tool, drive in the crankshaft oil seal into the right side cover to the point where the clearance between the bottom of the crankshaft oil seal and right side cover is 0.5 — 0.8 mm (0.02 — 0.03 in) (page 7-25).

NOTE: Align the hole in the driver attachment with the pin on the crankshaft.

**DRIVER
07749 — 0010000**

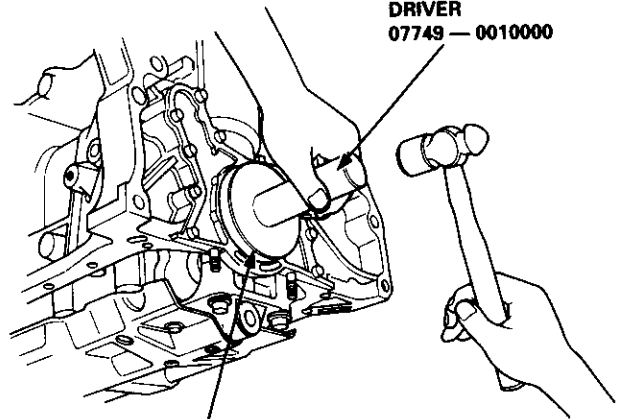

**DRIVER ATTACHMENT
07948 — SB00101**
Install seal with the
part number side
facing out.

Balancer Shafts



Inspection

NOTE: Inspect the balancer shaft before removing the right side cover and the balancer gear case (page 7-12).

1. Push the balancer shaft firmly away from the dial indicator, and zero the dial against the front end of the balancer shaft, then pull the balancer shaft firmly back toward the indicator.

Front Balancer Shaft End Play
Standard (New): 0.10 — 0.35 mm
(0.004 — 0.014 in)

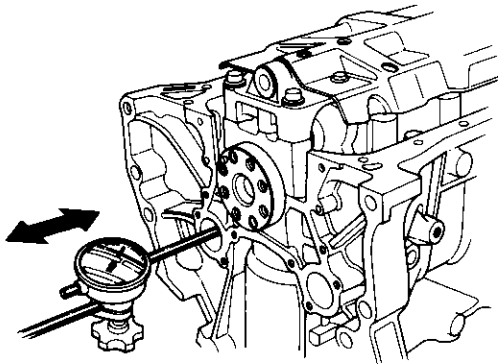

- If end play is excessive, inspect the retainer and thrust surfaces on the balancer shaft.

Rear Balancer Shaft End Play
Standard (New): 0.06 — 0.18 mm
(0.002 — 0.007 in)

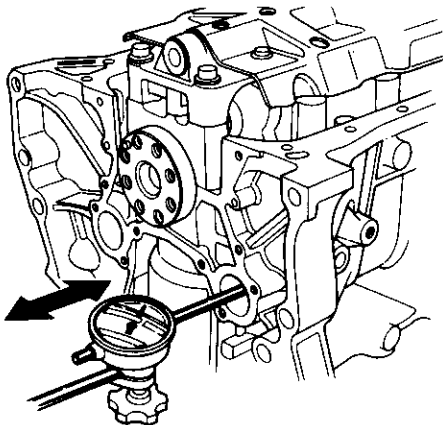

- If end play is excessive, inspect the thrust washer and thrust surfaces on the driven gear and oil pump body.

NOTE: The thickness of the retainer (front) and thrust washer (rear) are fixed and must not be changed either by grinding or shimming.

2. Remove the balancer shafts (page 7-12).

NOTE: Clean the balancer shafts.

3. Inspect the surface of the balancer shaft journal and balancer bearing.
4. Replace if there is wear, damage or discoloration on the surface of the bearing or the balancer shaft journal. When replacing the rear No. 1 bearing be sure to replace the oil pump housing with a new one.

NOTE: A mirror-like surface is normal.

5. Measure taper at the edges of each journal.
 - The difference between measurements on each journal.

Journal Taper
Standard (New): 0.005 mm (0.0002 in)

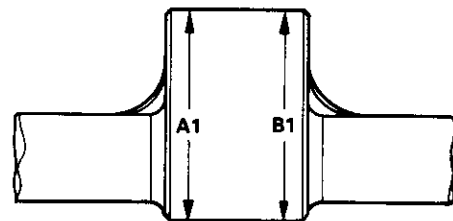
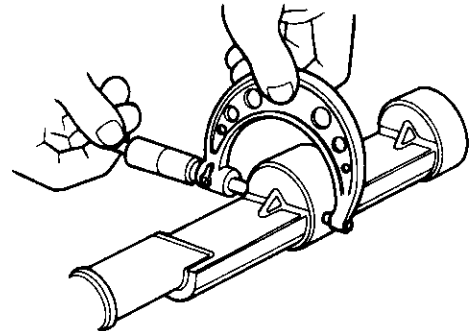

(cont'd)

Balancer Shafts

Inspection (cont'd)

- Measure runout on the No. 2 journal of each balancer shaft to make sure the balancer shafts are not bent.

Balancer Shaft Total Indicated Runout
Standard (New): 0.02 mm (0.001 in)
Service Limit: 0.03 mm (0.001 in)

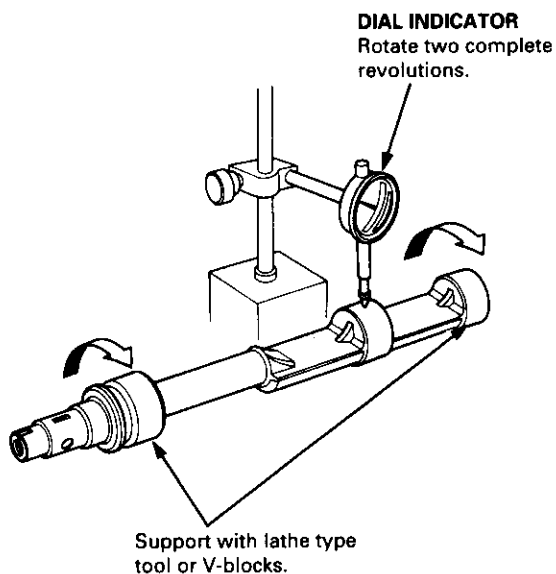

- Measure the diameters of the balancer shaft journals.

MEASURING POINTS

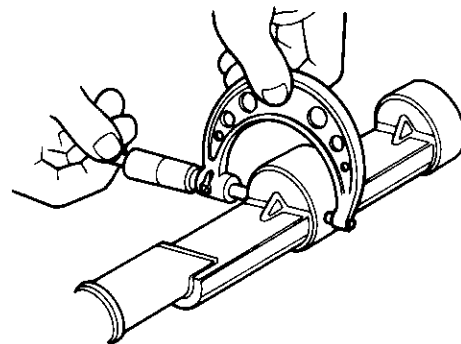
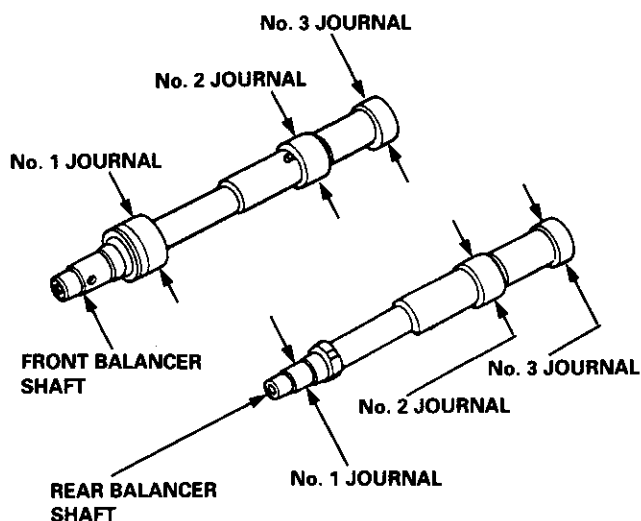

Journal Diameter

Standard (New)

No. 1 journal:

Front: 42.722 — 42.734 mm
(1.6820 — 1.6824 in)

Rear: 20.938 — 20.950 mm
(0.8243 — 0.8248 in)

No. 2 journal: 38.712 — 38.724 mm
(1.5241 — 1.5246 in)

No. 3 journal: 34.722 — 34.734 mm
(1.3670 — 1.3675 in)

Service Limit:

No. 1 journal:

Front: 42.71 mm (1.681 in)

Rear: 20.92 mm (0.824 in)

No. 2 journal: 38.70 mm (1.524 in)

No. 3 journal: 34.71 mm (1.367 in)

- Remove the crankshaft, the pistons and the other parts from the block, then clean the balancer shaft journal bearings of the block and the oil pump housing with a clean shop towel.
- Check the surface of the bearings, if there is wear, damage or discoloration, replace the bearings or the oil pump housing.



10. Measure the inner diameters of the balancer shaft journal bearings.

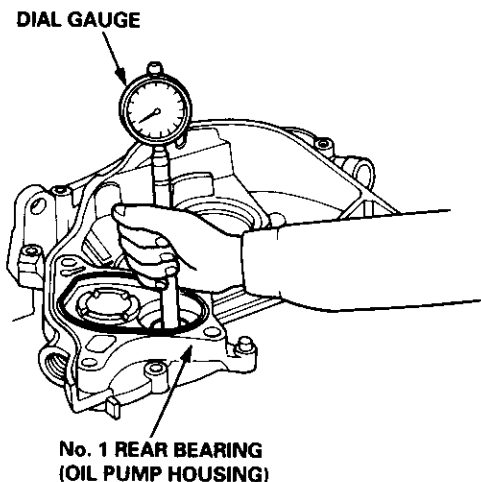
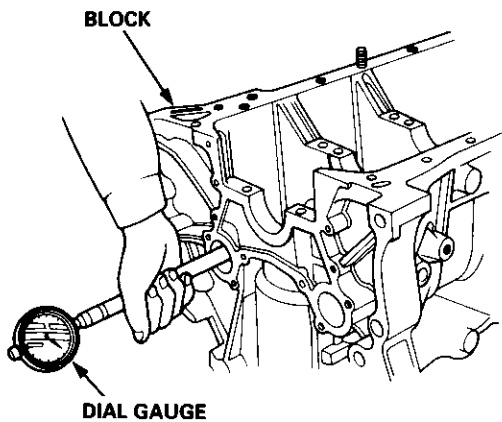
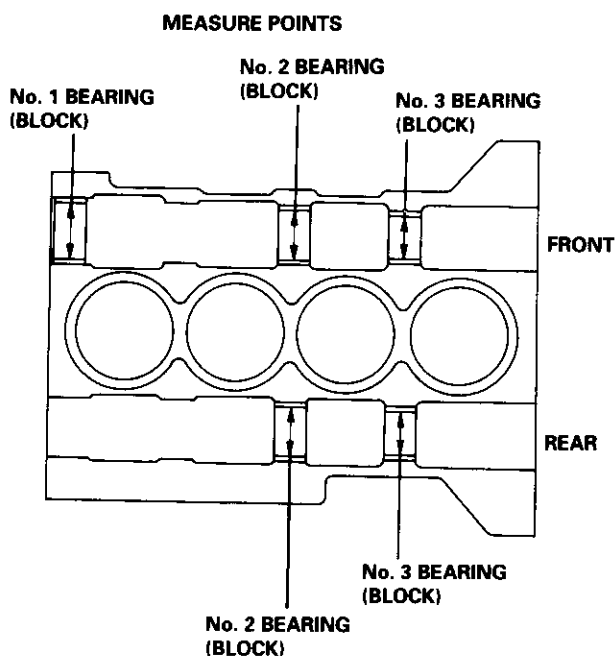

Bearing Inner Diameter

Standard (New):

No. 1 journals:

Front: 42.800 — 42.820 mm
(1.6850 — 1.6858 in)

Rear: 21.000 — 21.013 mm
(0.8268 — 0.8273 in)

No. 2 journals: 38.800 — 38.820 mm
(1.5276 — 1.5283 in)

No. 3 journals: 34.800 — 34.820 mm
(1.3701 — 1.3709 in)

Service Limit:

No. 1 journals:

Front: 42.83 mm (1.686 in)

Rear: 21.02 mm (0.828 in)

No. 2 journals: 38.83 mm (1.529 in)

No. 3 journals: 34.83 mm (1.371 in)

11. Calculate the shaft-to-bearings oil clearances.

BEARING I.D. - JOURNAL O.D. = OIL CLEARANCE

Bearing-to-shaft Oil Clearance

Standard (New)

No. 1 journal front and No. 3 journals:

0.066 — 0.118 mm (0.0026 — 0.0046 in)

No. 2 journals:

0.076 — 0.128 mm (0.0030 — 0.0050 in)

No. 1 journal rear:

0.050 — 0.075 mm (0.0020 — 0.0030 in)

Service Limit:

No. 1 journal front and No. 3 journals:

0.12 mm (0.005 in)

No. 2 journals: 0.13 mm (0.005 in)

No. 1 journal rear: 0.09 mm (0.004 in)

Engine Lubrication

Special Tools	8-2
Illustrated Index	8-3
Engine Oil	
Inspection	8-5
Replacement	8-5
Oil Filter	
Replacement	8-6
Oil Pressure	
Testing	8-8
Oil Jet	
Inspection (H22A1 engine only)	8-8
Oil Pump	
Overhaul	8-9
Removal/Inspection/Installation	8-10



Special Tools

Ref. No.	Tool Number	Description	Qty	Page Reference
①	07LAD — PT3010A	Seal Driver	1	8-11
②	07746 — 0010300	Attachment, 42 x 47 mm	1	8-11
③	07749 — 0010000	Driver	1	8-11
④	07912 — 6110001	Oil Filter Wrench	1	8-7

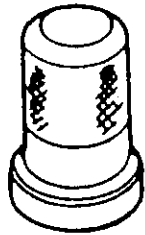

①

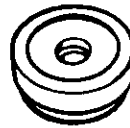

②



③

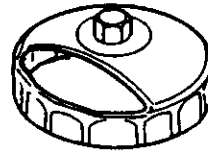

④

Illustrated Index



NOTE:

- Use new O-rings when reassembling.
- Apply oil to O-rings before installation.
- Use liquid gasket, Part No. 08718 — 0001.
- Clean the oil control orifice when installing.

CAUTION: Do not overtighten the drain plug.

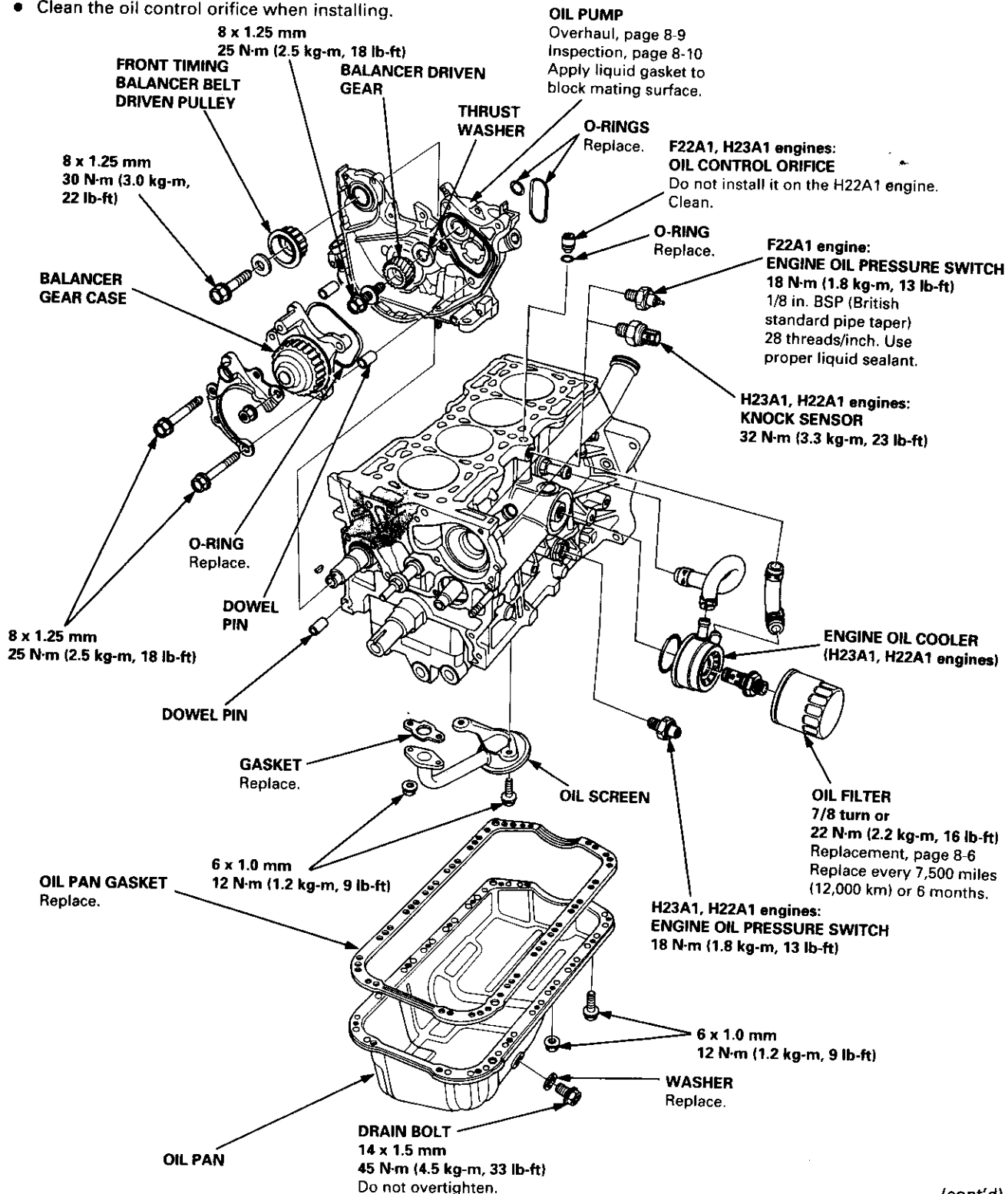

(cont'd)

Illustrated Index

(cont'd)

NOTE:

- Use new O-rings when reassembling.
- Apply oil to O-rings before installation.
- Use liquid gasket, Part No. 08718 — 0001.

11 x 1.5 mm
75 N-m (7.5 kg-m,
54 lb-ft)

Apply engine oil to the bolt
threads and the washers.

NOTE:

After torquing each cap,
turn crankshaft to check
for binding.

6 x 1.0 mm
12 N-m (1.2 kg-m, 9 lb-ft)

BAFFLE PLATE

BEARING CAP
BRIDGE

OIL JET BOLT
40 N-m (4.0 kg-m,
29 lb-ft)

OIL JET
Handle the nozzle with
care. Replace if any part
is damaged or deformed.

O-RING
Replace.

DOWEL PINS

H22A1
engine:

6 x 1.0 mm
12 N-m (1.2 kg-m, 9 lb-ft)

MAIN BEARING
CAPS

RIGHT
BREATHER COVER

LEFT
BREATHER COVER

CRANKSHAFT

THRUST WASHERS
Grooved sides face outward.

MAIN BEARINGS

CYLINDER BLOCK



Engine Oil

Inspection

1. Check engine oil with the engine off and the car parked on level ground.
2. Make certain that the oil level indicated on the dipstick is between the upper and lower marks.
3. If the level has dropped close to the lower mark, add oil until it reaches the upper mark.

CAUTION: Insert the dipstick carefully to avoid bending it.

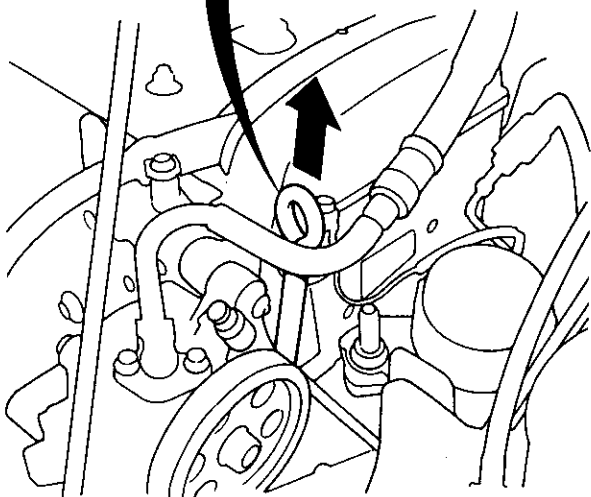
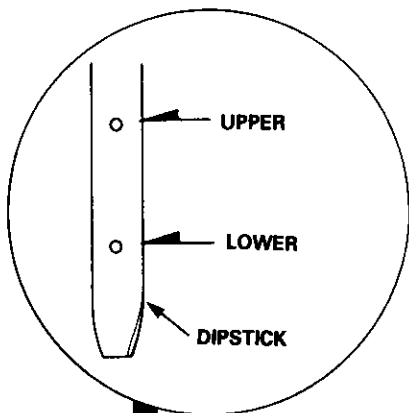

Replacement

CAUTION: Remove the drain bolt carefully while the engine is hot oil may cause scalding.

1. Warm up the engine.
2. Drain the engine oil.

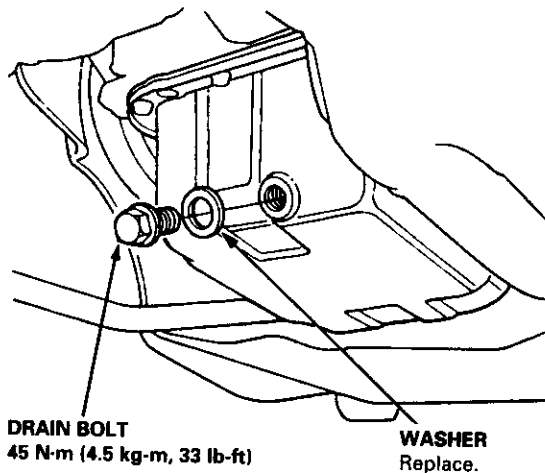

3. Reinstall the drain plug with a new washer, and refill with the recommended oil.

CAUTION: Do not overtighten the drain bolt.

Requirement	API Service Grade: Use "Energy Conserving II" SG grade oil. F22A1, H23A1 engines: 5 W — 30 preferred. H22A1 engine: 10 W — 30 preferred.
Capacity	F22A1 engine: 3.8 ℓ (4.0 US qt, 3.3 Imp qt) change, including filter. 4.9 ℓ (5.2 US qt, 4.3 Imp qt) after engine overhaul. H23A1 engine: 4.3 ℓ (4.5 US qt, 3.8 Imp qt) change, including filter. 5.4 ℓ (5.7 US qt, 4.8 Imp qt) after engine overhaul. H22A1 engine: 4.8 ℓ (5.1 US qt, 4.2 Imp qt) change, including filter. 5.9 ℓ (6.2 US qt, 5.2 Imp qt) after engine overhaul.
Change	Every 7,500 miles (12,000 km) or 6 months

(cont'd)

Engine Oil

Replacement (cont'd)

The numbers in the middle of the API Service label tell you the oil's SAE viscosity or weight. Select the oil for your car according to this chart:

F22A1, H23A1 engines:

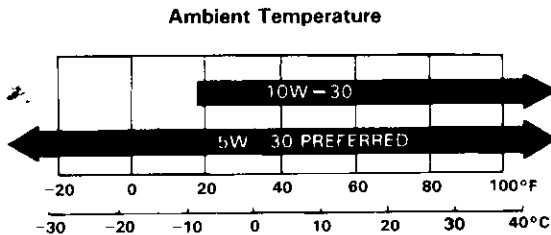

An oil with a viscosity of 5 W — 30 is preferred for improved fuel economy and year-round protection in the car. You may use a 10 W — 30 oil if the climate in your area is limited to the temperature range shown on the chart.

H22A1 engine:

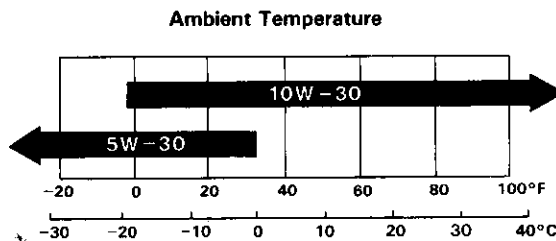

An oil with a viscosity of 10 W — 30 is preferred for improved fuel economy and year-round protection in the car. You may use a 5 W — 30 oil if the climate in your area is within the temperature range shown on the chart.

NOTE: The oil filter should be replaced at each oil change.

Oil Filter

Replacement

⚠ WARNING

- After the engine has been run, the exhaust pipe will be hot; be careful when working around the exhaust pipe.
- Be careful when loosening the drain bolt while the engine is hot. Burns can result because the oil temperature is very high.

1. Remove the oil filter with the special oil filter wrench.
2. Inspect the threads and rubber seal on the new filter. Wipe off seat on engine block, then apply a light coat of oil to the filter rubber seal.

NOTE: Use only filters with a built-in bypass system.

 Apply engine oil to rubber seal before installing.

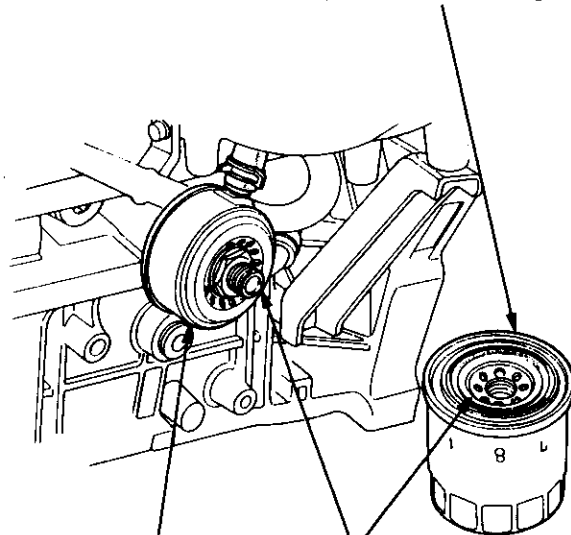

Inspect threads and rubber seal surface.

ENGINE OIL COOLER
(H23A1, H22A1 engines)



3. Install the oil filter by hand.
4. After the rubber seal seats, tighten the oil filter clockwise with the special tool.

Tighten: 7/8 turn clockwise

Tightening torque: 22 N·m (2.2 kg·m, 16 lb·ft)

CAUTION: Installation other than the above procedure could result in serious engine damage due to oil leakage.

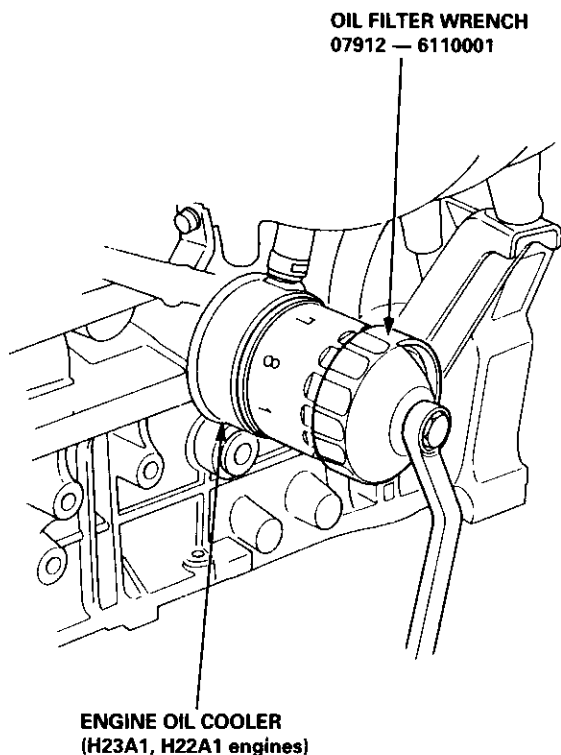

Eight numbers (1 to 8) are printed on the surface of the filter.

The following explains the procedure for tightening filters using these numbers.

- 1) Make a mark on the cylinder block under the number that shows at the bottom of the filter when the rubber seal is seated.
- 2) Tighten the filter by turning it clockwise seven numbers from the marked point. For example, if a mark is made under the number 2 when the rubber seal is seated, the filter should be tightened until the number 1 comes up to the marked point.

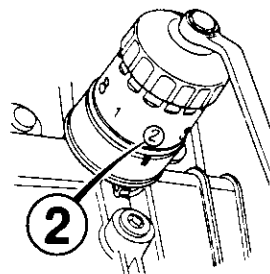

Number when rubber seal is seated.

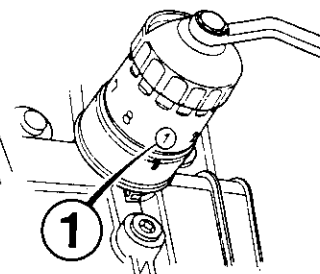

Number after tightening.

Number when rubber seal is seated	1	2	3	4	5	6	7	8
Number after tightening	8	1	2	3	4	5	6	7

5. After installation, fill the engine with oil up to the specified level, run the engine for more than 3 minutes, then check for oil leakage.

Oil Pressure

Testing

If the oil pressure warning light stays on with the engine running, check the engine oil level. If the oil level is correct:

1. Connect a tachometer.
2. Remove the engine oil pressure switch and install an oil pressure gauge.
3. Start the engine. Shut it off immediately if the gauge registers no oil pressure. Repair the problem before continuing.
4. Allow the engine to reach operating temperature (radiator fan comes on at least twice). The pressure should be:

Engine Oil Temperature: 176°F (80°C)

Engine Oil Pressure:

**At Idle: 70 kPa (0.7 kg/cm², 10.0 psi)
minimum**

**At 3,000 rpm: 350 kPa (3.5 kg/cm², 50 psi)
minimum**

- If oil pressure is within specifications, replace the oil pressure switch and recheck.
- If oil pressure is NOT within specifications, inspect the oil pump (pages 8-10, 11).

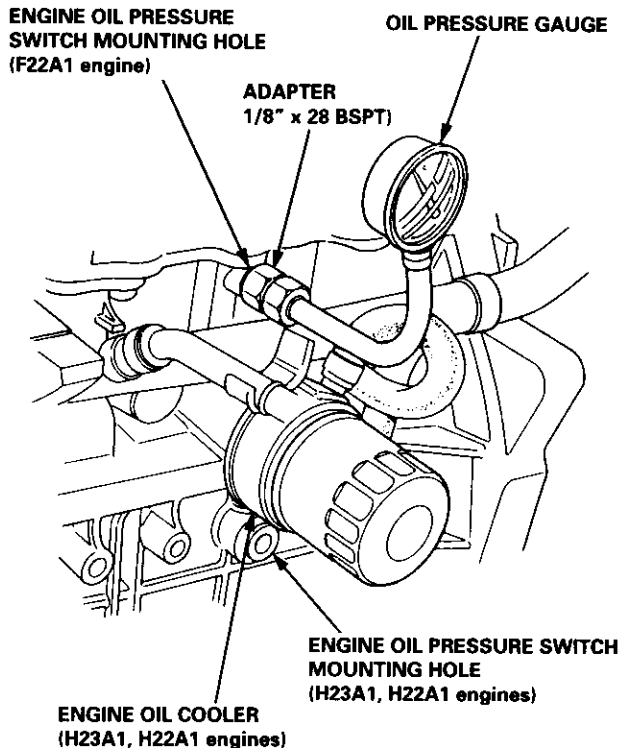

Oil Jet

Inspection (H22A1 engine only)

1. Remove the oil jet (page 8-4) and inspect it as follows.
 - Make sure that a 1.1 mm (0.04 in) diameter drill will go through the nozzle hole (1.2 mm (0.05 in) diameter).
 - Insert the other end of the same 1.1 mm (0.04 in) drill into the oil intake (1.2 mm (0.05 in) diameter). Make sure the check ball moves smoothly and has a stroke of approximately 4.0 mm (0.16 in).
 - Check the oil jet operation with an air nozzle. It should take at least 200 kPa (2.0 kg/cm², 28 psi) to unseat the check ball.

NOTE: Replace the oil jet assembly if the nozzle is damaged or bent.

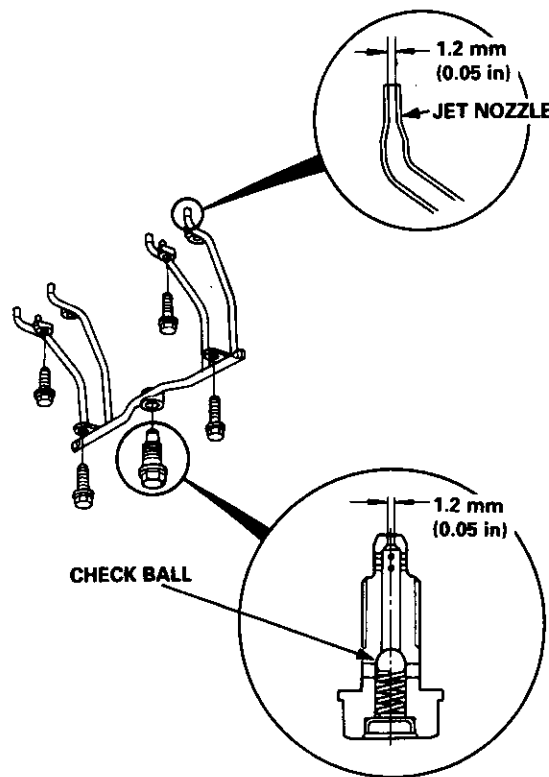

2. Mounting torque is critical. Be very precise when installing.

Torque: 40 N·m (4.0 kg·m, 29 lb·ft)



Oil Pump

Overhaul

NOTE:

- Use new O-rings when reassembling.
- Apply oil to O-rings before installation.
- Use liquid gasket, Part No. 08718 — 0001.

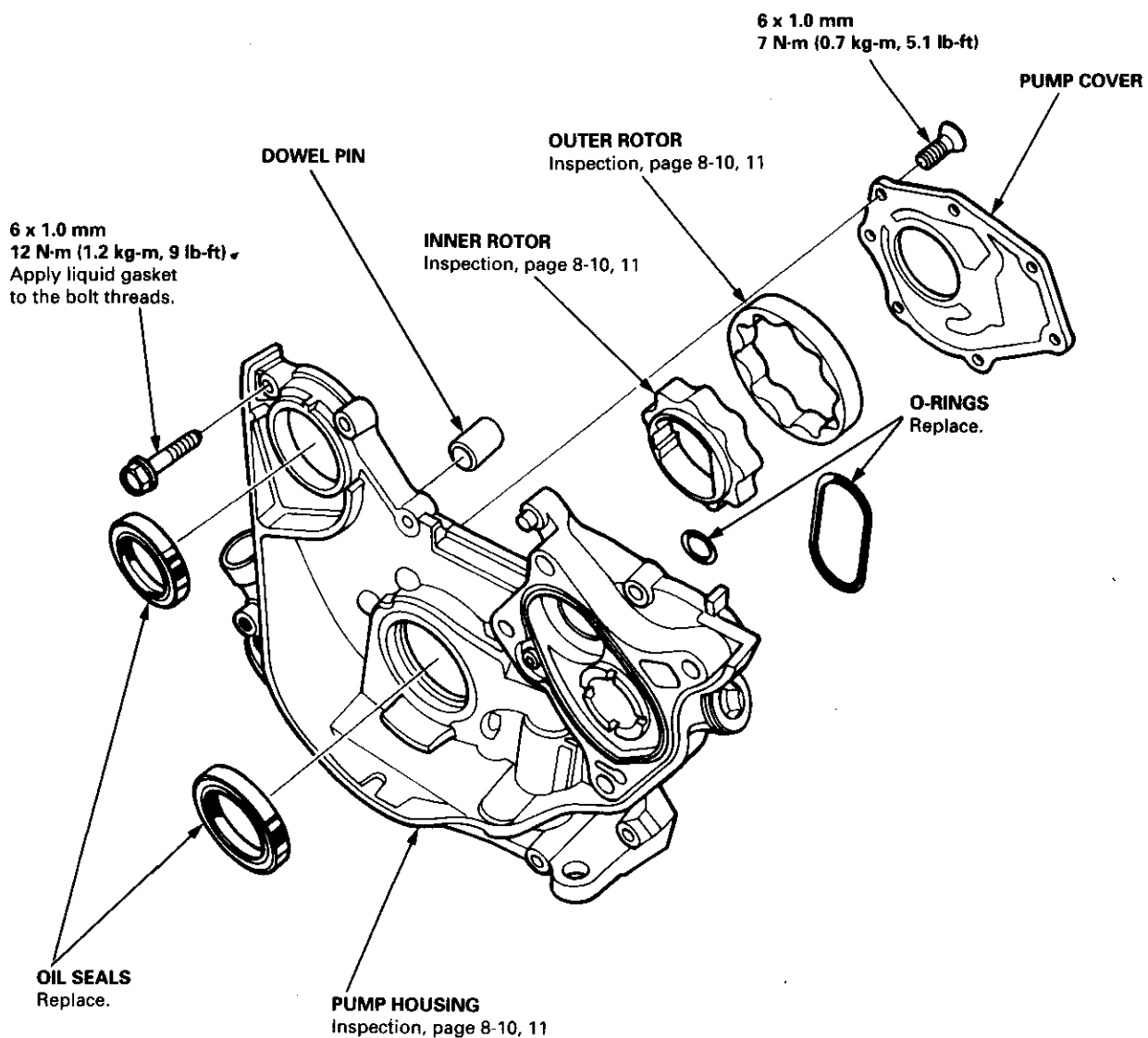

Oil Pump

Removal/Inspection/Installation

1. Drain the engine oil.
2. Turn the crankshaft so that the No. 1 piston is at top dead center (F22A1 engine: page 6-28, H23A1 engine: page 6-62, H22A1 engine: page 6-106).
3. Remove the timing belt and the timing balancer belt (F22A1 engine: page 6-29, H23A1 engine: page 6-63, H22A1 engine: page 6-107).
4. Remove the timing belt tensioner and the timing balancer belt tensioner.
5. Remove the timing belt drive pulley and the timing balancer belt driven pulley (page 7-12).
6. Remove the balancer gear case and the balancer driven gear (page 7-12).
7. Remove the oil pan and the oil screen.
8. Remove the mounting bolts and the oil pump assembly.

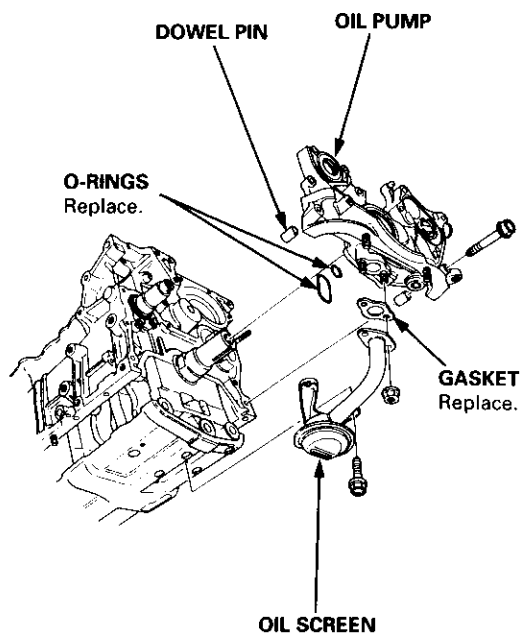

9. Remove the screws from the pump housing, then separate the housing and cover.
10. Check the inner-to-outer rotor radial clearance on the pump rotor.

Inner Rotor-to-Outer Rotor Radial Clearance
Standard (New): 0.02 — 0.16 mm (0.001 — 0.006 in)
Service Limit: 0.20 mm (0.008 in)

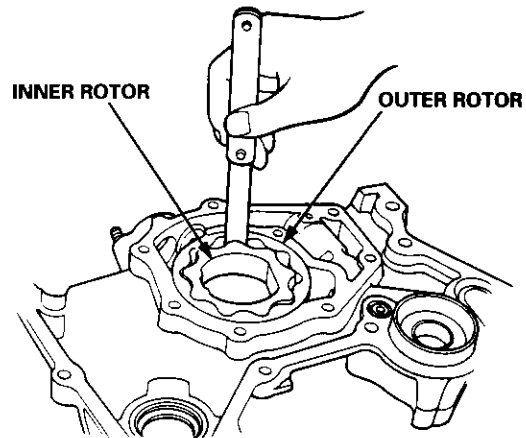

— If the inner-to-outer rotor clearance exceeds the service limit, replace the inner and outer rotors.

11. Check the housing-to-rotor axial clearance on the pump rotor.

Housing-to-Rotor Axial Clearance
Standard (New): 0.02 — 0.07 mm (0.001 — 0.003 in)
Service Limit: 0.12 mm (0.005 in)

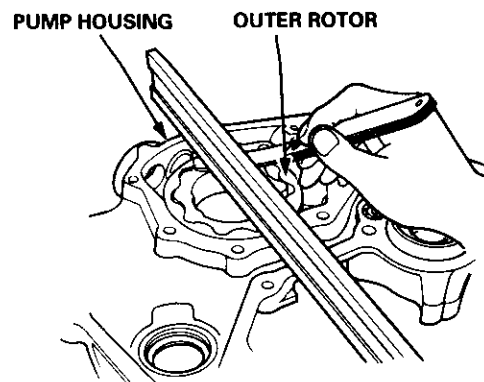

— If the housing-to-rotor axial clearance exceeds the service limit, replace the set of inner and outer rotors and/or the pump housing.



12. Check the housing-to-outer rotor radial clearance.

Housing-to-Outer Rotor Radial Clearance
Standard (New): 0.10 — 0.19 mm (0.004 — 0.007 in)
Service Limit: 0.21 mm (0.008 in)

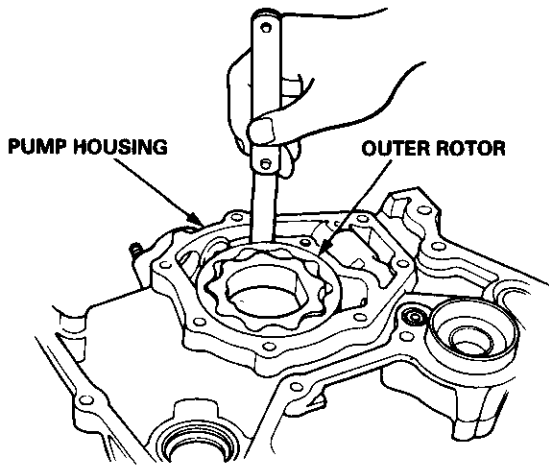

— If the housing-to-outer rotor radial clearance exceeds the service limit, replace the set of inner and outer rotors and/or the pump housing.

13. Inspect both rotors and the pump housing for scoring or other damage. Replace parts if necessary.
14. Remove the old oil seals from the oil pump.
15. Gently tap in the new oil seals until the special tool bottoms on the pump.

NOTE: The oil seals alone can be replaced without removing the oil pump using the special tool.

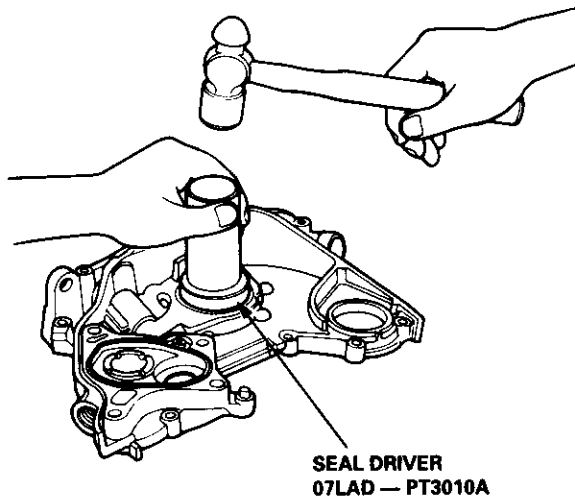

DRIVER
07749 — 0010000

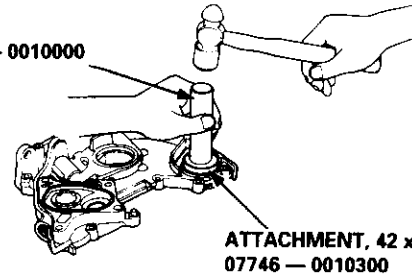

ATTACHMENT, 42 x 47 mm
07746 — 0010300

16. Reassemble the oil pump, applying liquid thread lock to the pump housing screws.
17. Check that the oil pump turns freely.
18. Install a dowel pin and the new O-ring on the pump.

NOTE:

- Use liquid gasket, Part No. 08718 — 0001.
- Check that the mating surfaces are clean and dry before applying liquid gasket.
- Apply liquid gasket evenly, in a narrow bead centered on the mating surface.
- To prevent leakage of oil, apply liquid gasket to the inner threads of the bolt holes.
- Do not install the parts if 20 minutes or more have elapsed since applying liquid gasket. Instead reapply liquid gasket after removing the old residue.
- After assembly, wait at least 30 minutes before filling the engine with oil.

19. Apply liquid gasket to the oil pump and install it.

- Apply grease to the lips of the crankshaft oil seal and the balancer shaft seal. Then, install the oil pump inner rotor onto the crankshaft. When the pump is in place, clean any excess grease off the crankshaft and the balancer shaft, then check that the oil seal lips are not distorted.

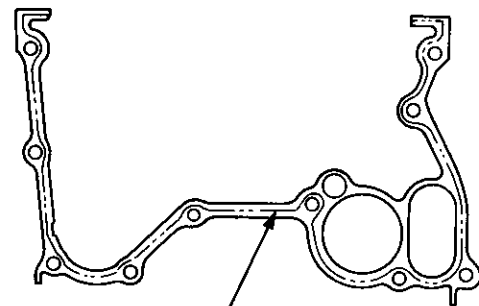

Apply liquid gasket along the broken line.

(cont'd)

Oil Pump

Removal/Inspection/Installation (cont'd)

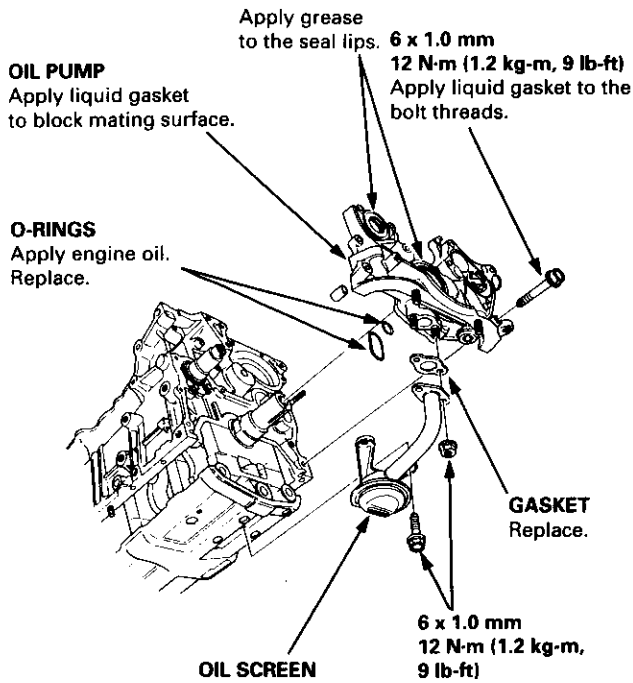

20. Install the baffle plate.

21. Install the oil screen.

22. Apply molybdenum disulfide to the thrust surfaces of the balancer gears, as shown, before installing the balancer driven gear and the balancer gear case.

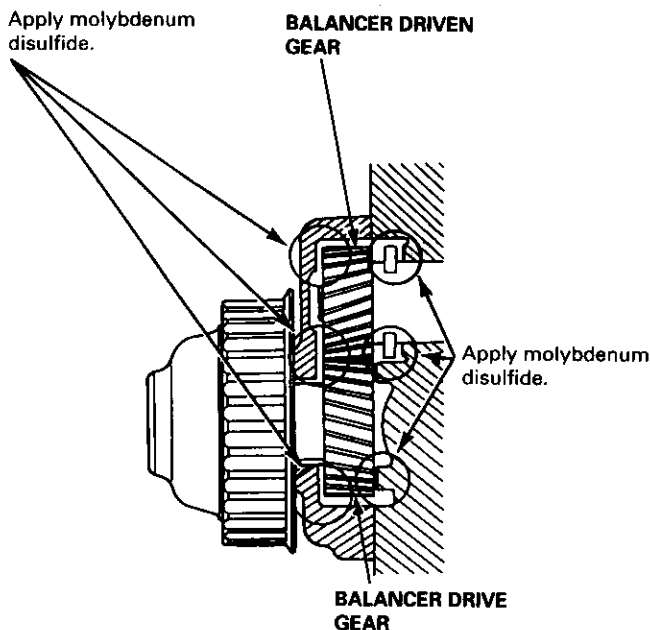

23. Hold the rear balancer shaft with the 6 x 100 mm bolt, then install the balancer driven gear.

REAR BALANCER:

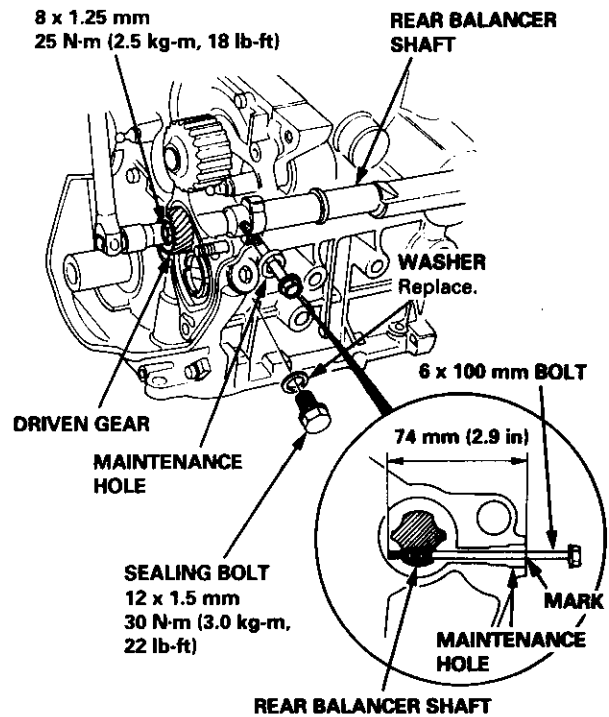

24. Hold the front balancer shaft with a screwdriver, then install the timing balancer belt driven pulley.

FRONT BALANCER:

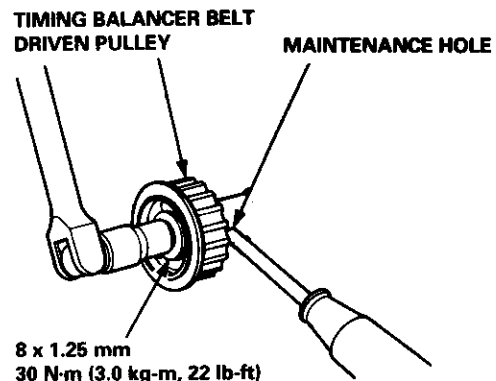



25. Install the balancer gear case on the oil pump.

NOTE: Align the groove on the pulley edge to the pointer on the gear case while holding the rear balancer with the 6 x 100 mm bolt, then install the gear case.

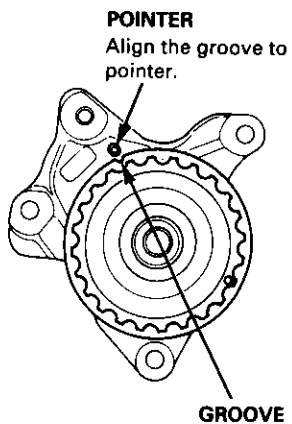
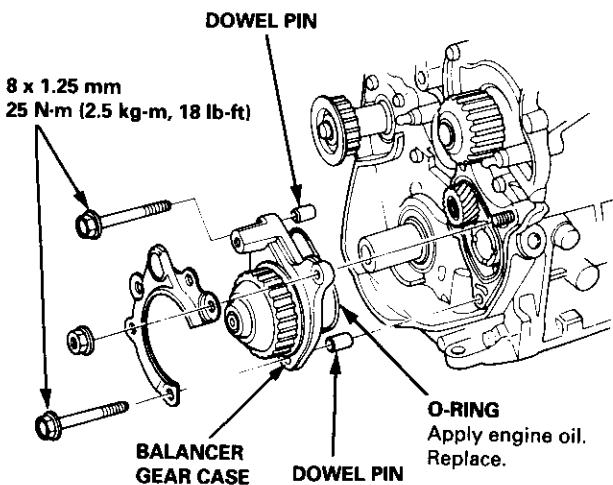

26. Check alignment of pointers after installing the gear case.

POINTNER ON THE PULLEY

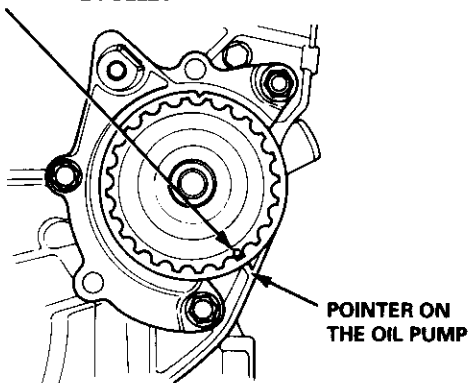

27. Install the oil pan.

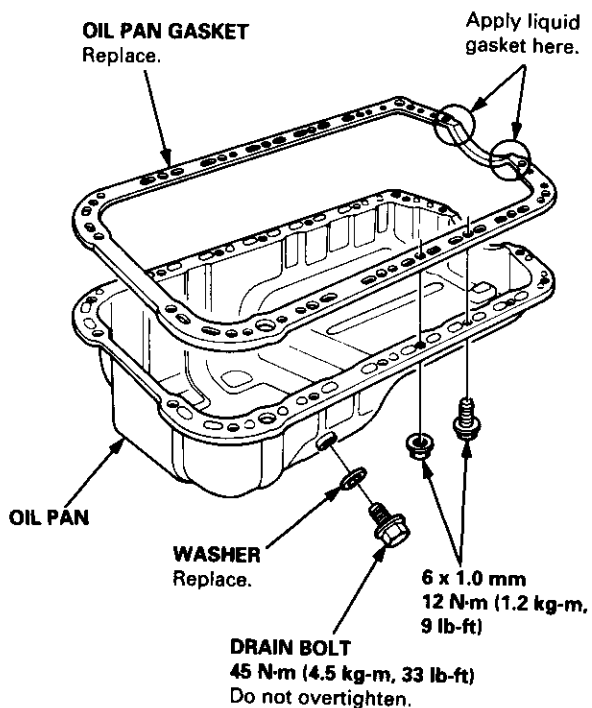

28. Tighten the bolts and nuts as shown below.

Torque: 12 N-m (1.2 kg-m, 9 lb-ft)

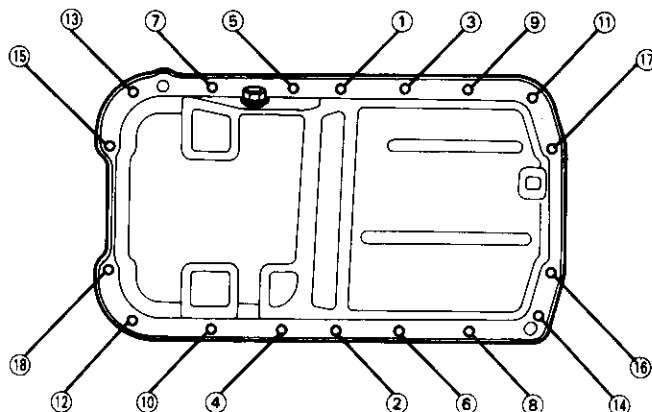

NOTE: Tighten the bolts and nuts in two steps and torque them in a crisscross pattern.

Intake Manifold/Exhaust System

Intake Manifold

Replacement 9-2

Exhaust Manifold

Replacement 9-4

Exhaust Pipe and Muffler

Replacement 9-7



Intake Manifold

Replacement

NOTE: Use new O-rings and gaskets when reassembling.

CAUTION:

- Check for folds or scratches on the surface of the gasket.
- Replace with a new gasket if damaged.

H23A1, H22A1 engines: 8 x 1.25 mm
22 N·m (2.2 kg-m, 16 lb-ft)

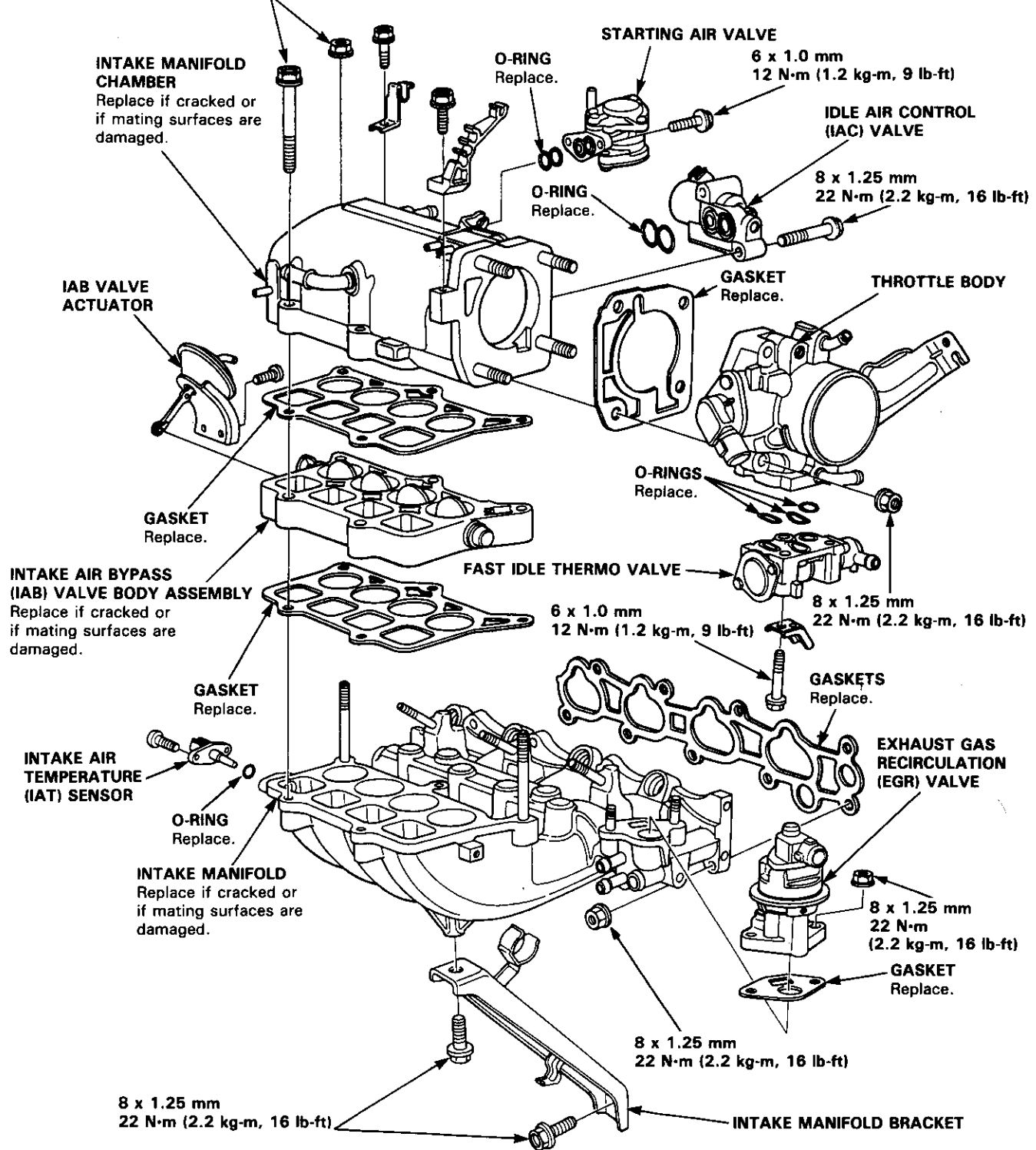



NOTE: Use new O-rings and gaskets when reassembling.

CAUTION:

- Check for folds or scratches on the surface of the gasket.
- Replace with a new gasket if damaged.

F22A1 engine:

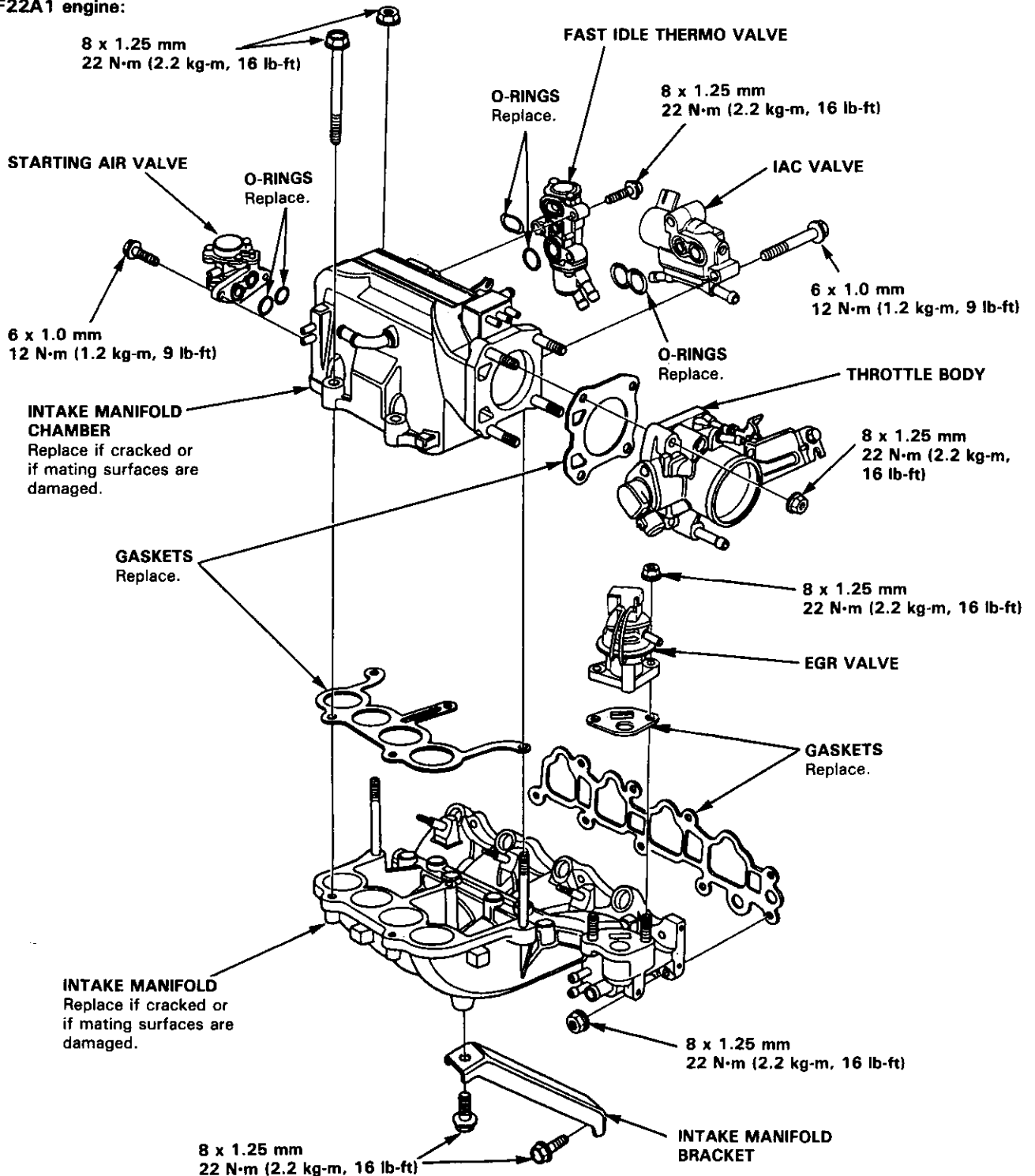

Exhaust Manifold

Replacement

NOTE: Use new gaskets and self-locking nuts when reassembling.

CAUTION:

- Check for folds or scratches on the surface of the gasket.
- Replace with a new gasket if damaged.

H23A1 engine:

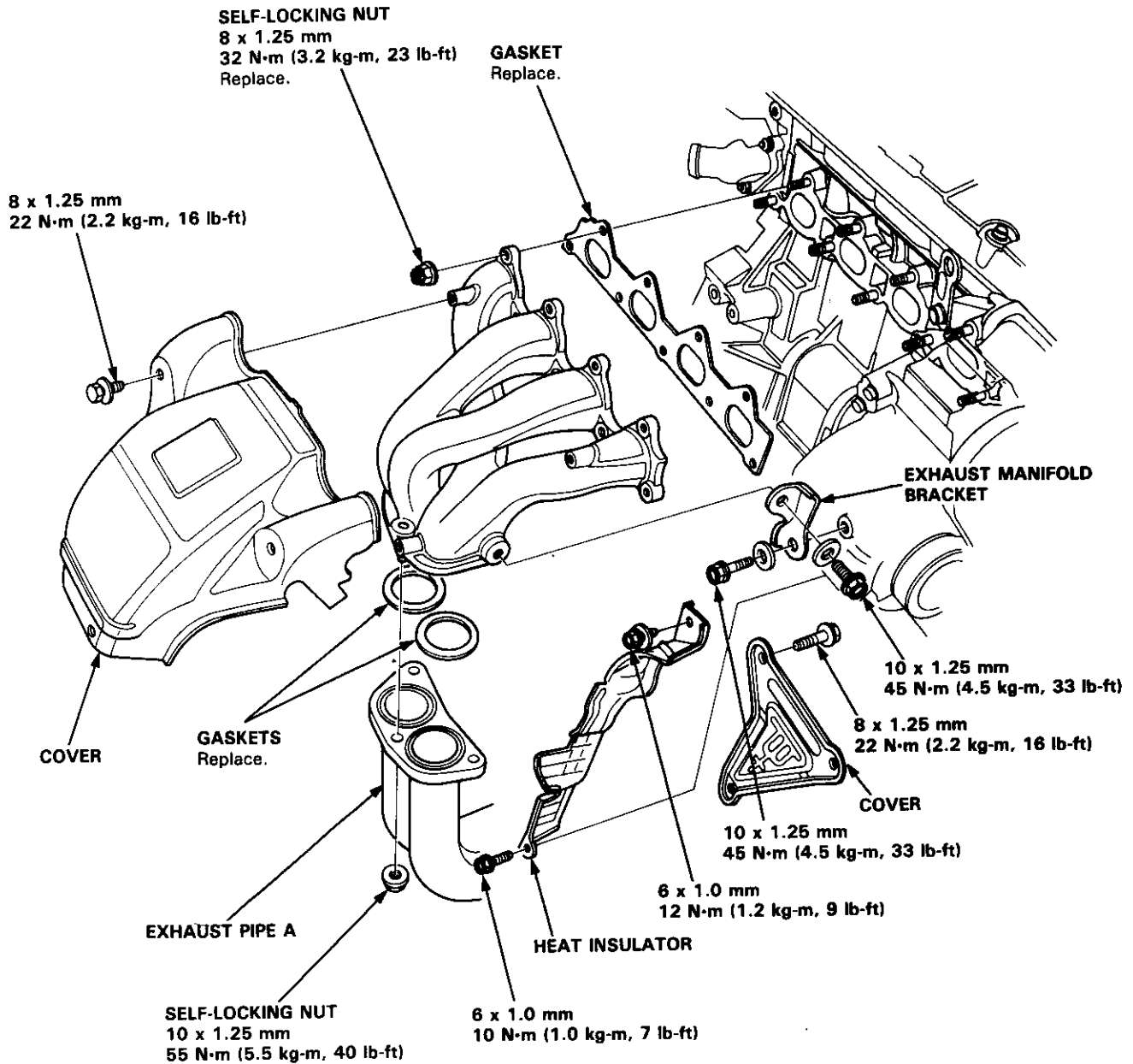



NOTE: Use new gaskets and self-locking nuts when reassembling.

CAUTION:

- Check for folds or scratches on the surface of the gasket.
- Replace with a new gasket if damaged.

F22A1 engine:

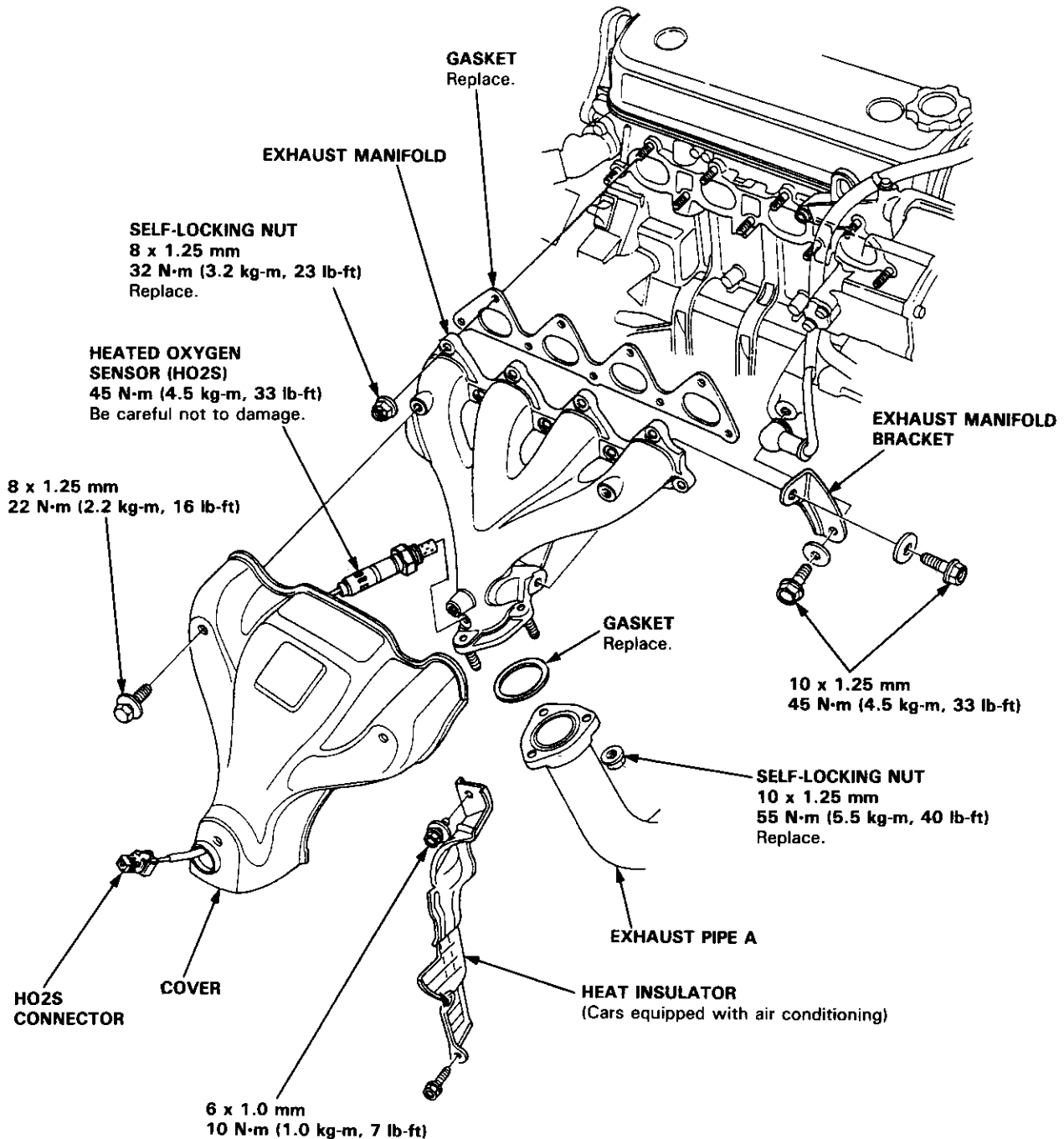

Exhaust Manifold

Replacement

NOTE: Use new gaskets and self-locking nuts when reassembling.

CAUTION:

- Check for folds or scratches on the surface of the gasket.
- Replace with a new gasket if damaged.

H22A1 engine:

SELF-LOCKING NUT
8 x 1.25 mm
32 N·m (3.2 kg-m, 23 lb-ft)
Replace.

GASKET
Replace.

EXHAUST MANIFOLD

COVER

10 x 1.25 mm
45 N·m (4.5 kg-m,
33 lb-ft)

GASKETS
Replace.

8 x 1.25 mm
22 N·m (2.2 kg-m, 16 lb-ft)

COVER

HEAT INSULATOR

SELF-LOCKING NUT
10 x 1.25 mm
55 N·m (5.5 kg-m, 40 lb-ft)

8 x 1.25 mm
22 N·m (2.2 kg-m, 16 lb-ft)

EXHAUST PIPE A

6 x 1.0 mm
10 N·m (1.0 kg-m, 7 lb-ft)



Exhaust Pipe and Muffler

Replacement

NOTE: Use new gaskets and self-locking nuts when reassembling.

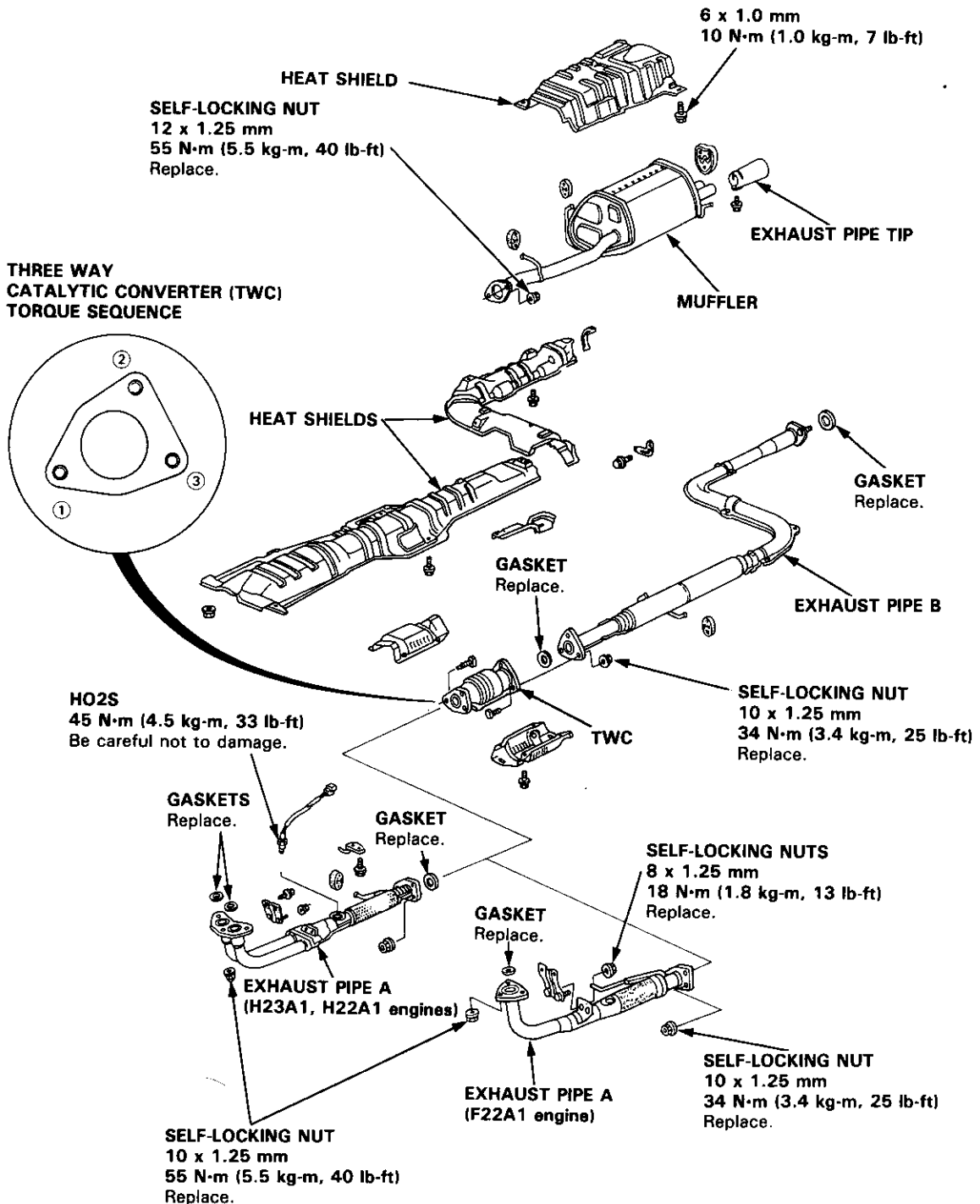

Cooling

Radiator

Illustrated Index	10-2
Replacement	10-5
Engine Coolant Refilling and Bleeding	10-6
Cap Testing	10-7
Testing	10-7

Thermostat

Replacement	10-8
Testing	10-9

Water Pump

Illustrated Index	10-10
Inspection	10-12
Replacement	10-12



Radiator

Illustrated Index

▲ WARNING System is under high pressure when engine is hot. To avoid danger of releasing scalding coolant, remove cap only when engine is cool.

Total Cooling System Capacity (Including heater and reservoir)

F22A1 engine:

Manual: 7.1 ℓ (7.5 US qt, 6.2 Imp qt)

Automatic: 7.0 ℓ (7.4 US qt, 6.2 Imp qt)

H23A1 engine:

Manual: 7.4 ℓ (7.8 US qt, 6.5 Imp qt)

Automatic: 7.3 ℓ (7.7 US qt, 6.4 Imp qt)

H22A1 engine:

Manual: 7.6 ℓ (8.0 US qt, 6.7 Imp qt)

Reservoir capacity: 0.6 ℓ (0.6 US qt, 0.5 Imp qt)

CAUTION: When pouring engine coolant, be sure to shut the relay box lid and not to spill coolant on the electrical parts or the painted portion. If any coolant spills, rinse it off immediately.

NOTE:

- Check all cooling system hoses for damage, leaks or deterioration and replace if necessary.
- Check all hose clamps and retighten if necessary.
- Use new O-rings when reassembling.

RADIATOR

Engine coolant

Refilling and bleeding, page 10-6

Leak test, page 10-7

Inspect soldered joints and seams for leaks.

Blow out dirt from between core fins with compressed air.

If insects, etc., are clogging radiator, wash them off with low pressure water.

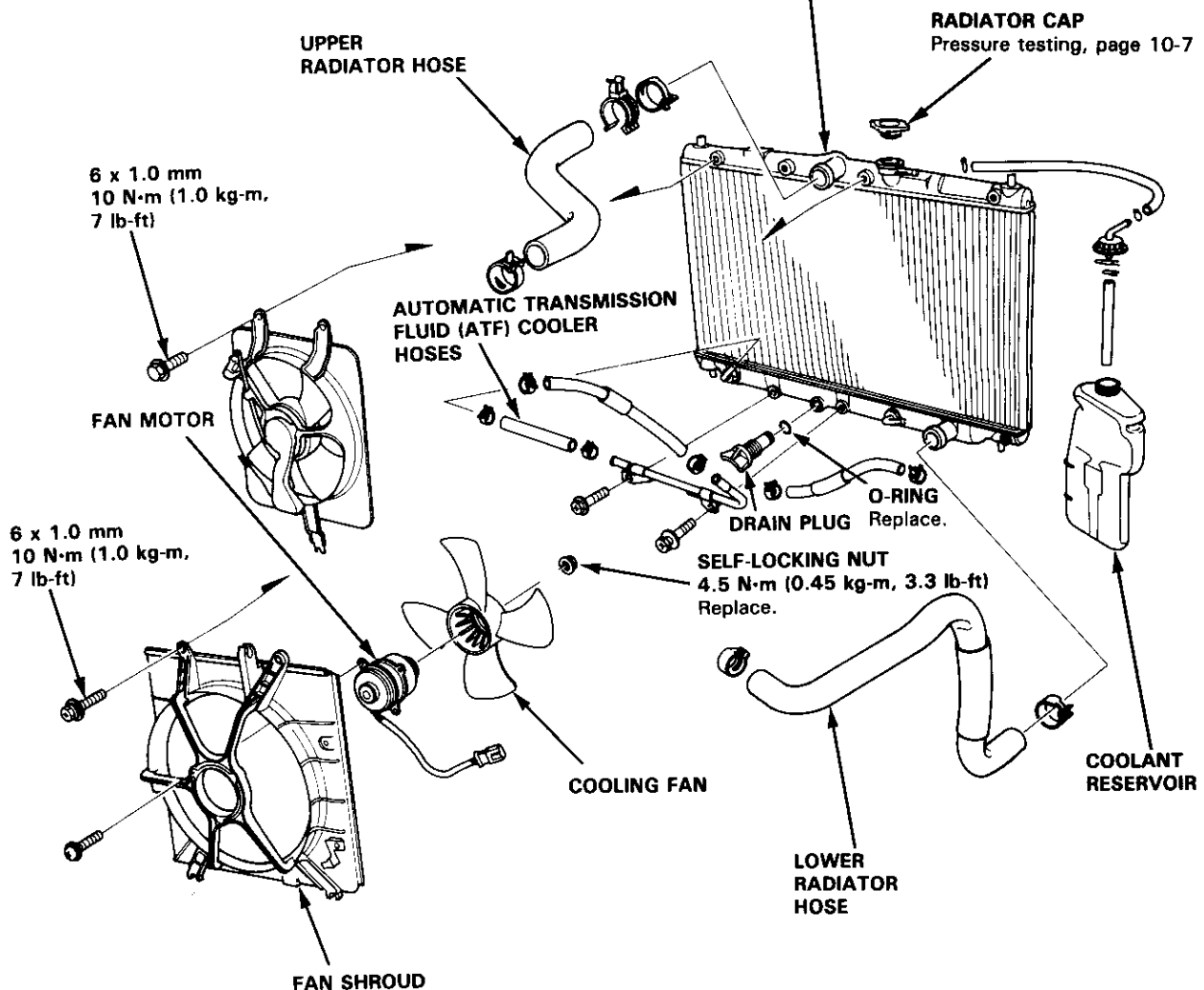



Engine Hose Connections:

F22A1 engine:

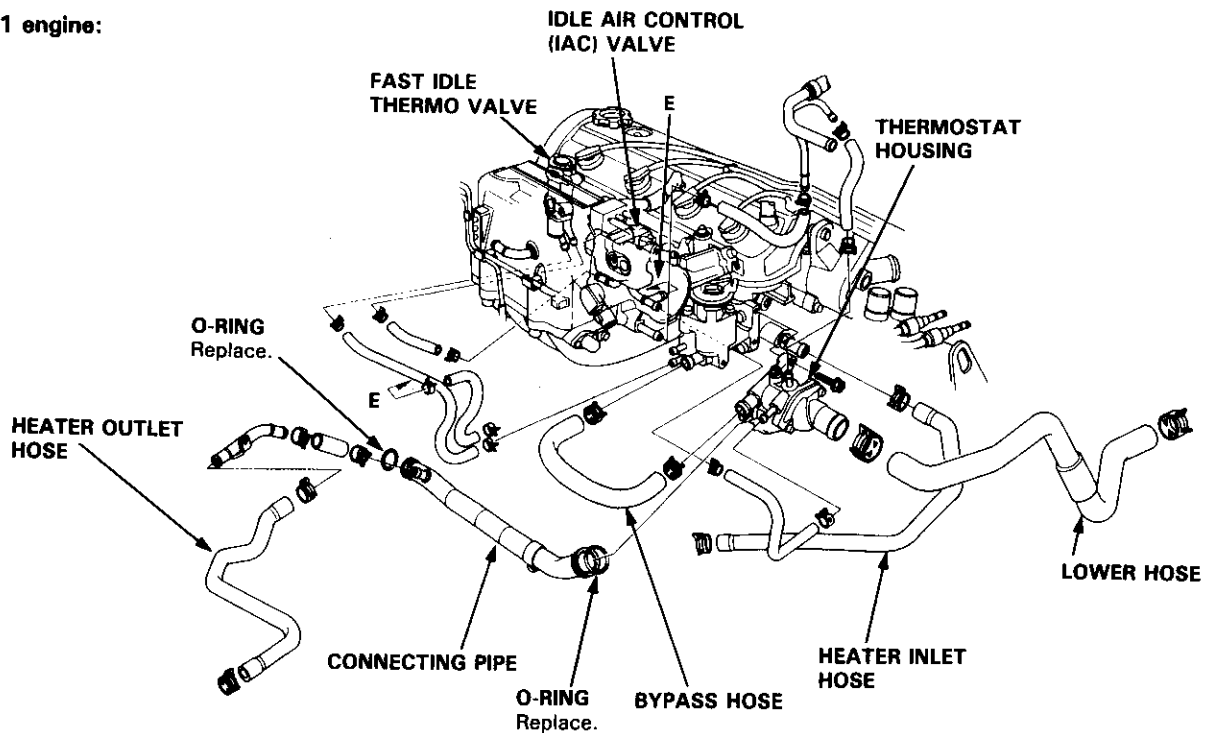

H23A1 engine:

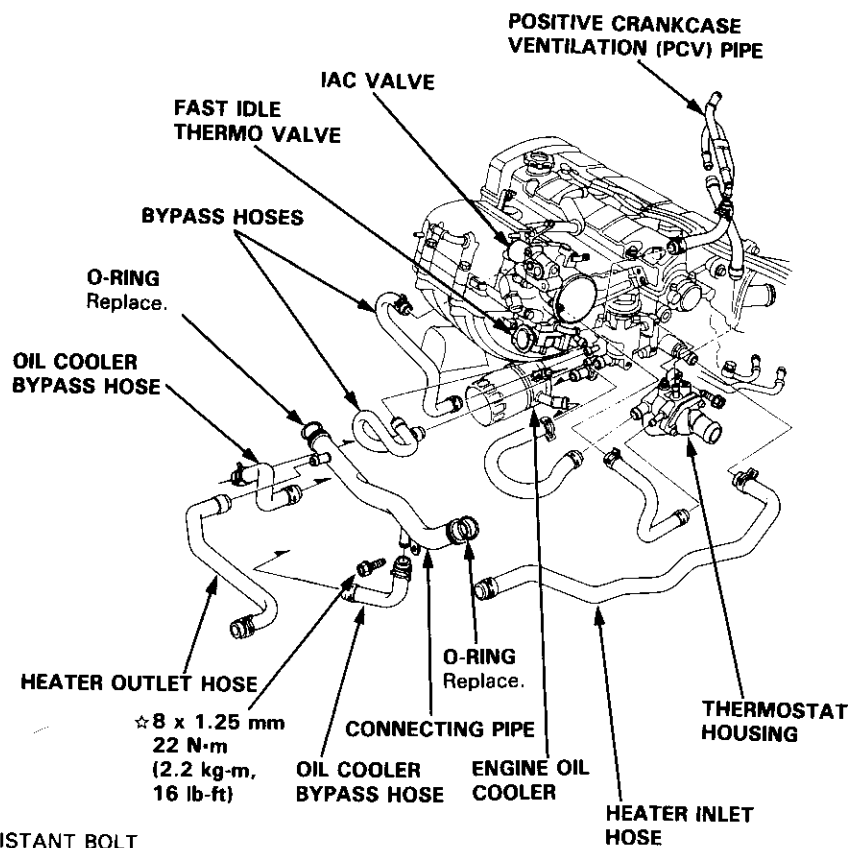

☆ CORROSION RESISTANT BOLT

(cont'd)

Radiator

Illustrated Index (cont'd)

Engine Hose Connections:

H22A1 engine:

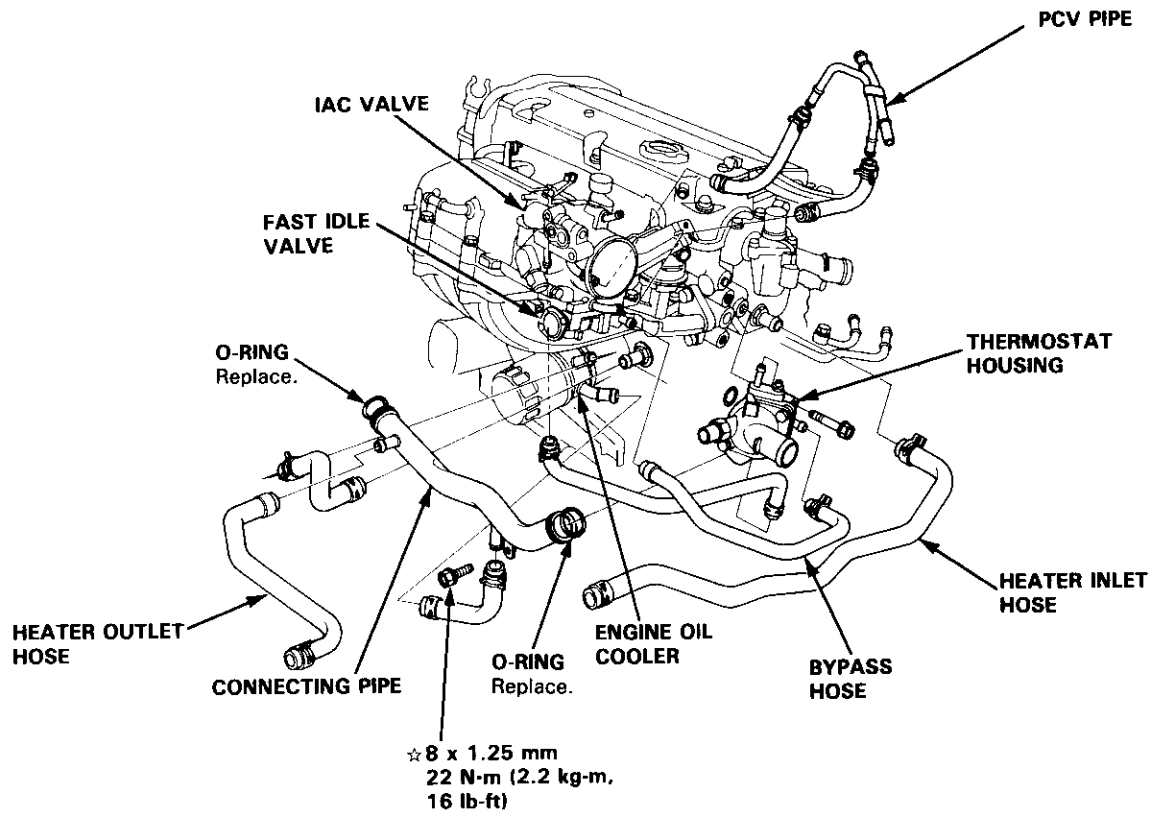

☆: CORROSION RESISTANT BOLT



Replacement

1. Drain engine coolant.
2. Remove the upper and lower radiator hoses, and ATF cooler hoses.
3. Disconnect the fan motor connectors.
4. Remove the radiator upper brackets, then pull up the radiator.

5. Remove the fan shroud assemblies and other parts from radiator.

Install the radiator in the reverse order of removal:

NOTE:

- Set the upper and lower cushions securely.
- Fill the radiator with engine coolant and bleed the air.

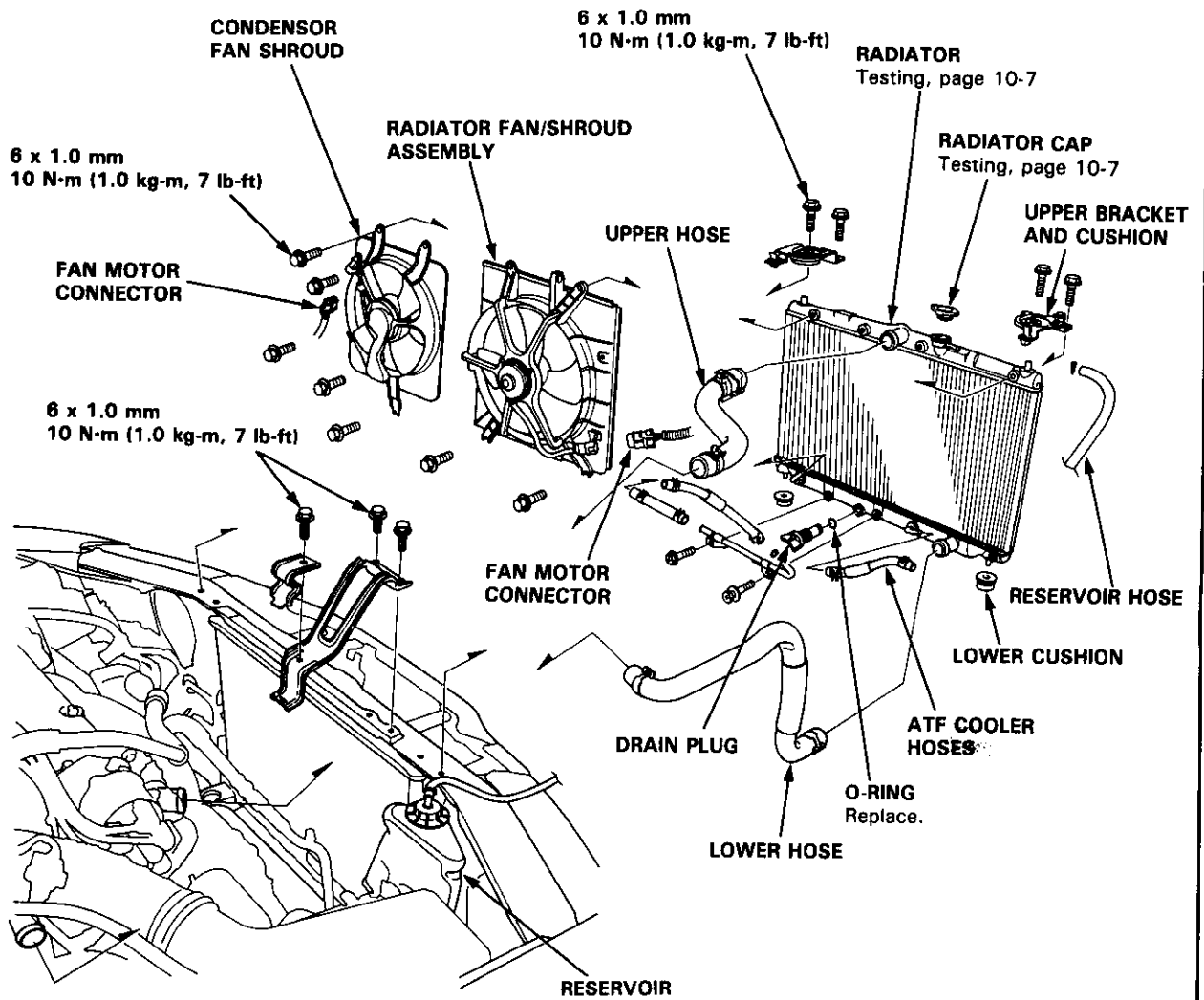

Radiator

Engine Coolant Refilling and Bleeding

CAUTION: When pouring engine coolant, be sure to shut the relay box lid and not to let coolant spill on the electrical parts or the paint. If any coolant spills, rinse it off immediately.

1. Set the heater temperature lever or control dial to maximum heat.
2. Remove the engine splash shield.
3. When the radiator is cool, remove the radiator cap. Loosen the drain plug, and drain the coolant.
4. Remove the drain bolt from the rear side of the cylinder block to drain the block and heater.
5. Apply liquid gasket to the drain bolt threads, then reinstall the bolt with a new washer and tighten it securely.
6. Tighten the radiator drain plug securely.
7. Remove, drain and reinstall the reservoir. Fill the tank halfway to the MAX mark with water, then up to the MAX mark with anti-freeze.
8. Mix the recommended anti-freeze with an equal amount of water in a clean container.

NOTE:

- Use only genuine Honda anti-freeze/coolant.
- For best corrosion protection, the coolant concentration must be maintained year-round at 50% minimum. Coolant concentrations less than 50% may not provide sufficient protection against corrosion or freezing.
- Coolant concentrations greater than 60% will impair cooling efficiency and are not recommended.

CAUTION:

- Do not mix different brands of anti-freeze/coolants.
- Do not use additional rust inhibitors or anti-rust products; they may not be compatible with the genuine coolant.

Engine Coolant Refill Capacity: including reservoir (0.6 ℓ (0.6 US qt, 0.5 Imp qt)) and heater (0.6 ℓ (0.6 US qt, 0.5 Imp qt)).

F22A1 engine:

Manual: 3.5 ℓ (3.7 US qt, 3.1 Imp qt)
Automatic: 3.4 ℓ (3.6 US qt, 3.0 Imp qt)

H23A1 engine:

Manual: 3.8 ℓ (4.0 US qt, 3.3 Imp qt)
Automatic: 3.7 ℓ (3.9 US qt, 3.3 Imp qt)

H22A1 engine:

Manual: 4.0 ℓ (4.2 US qt, 3.5 Imp qt)

9. Loosen the air bleed bolt in the thermostat housing, then fill the radiator to the bottom of the filler neck with the coolant mixture. Tighten the bleed bolt as soon as coolant starts to run out in a steady stream without bubbles.

BLEED BOLT
10 N·m (1.0 kg-m, 7 lb-ft)

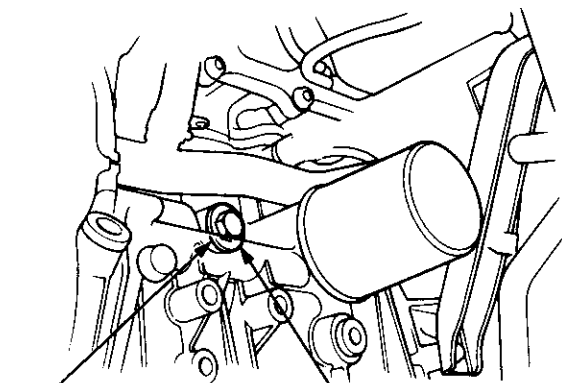
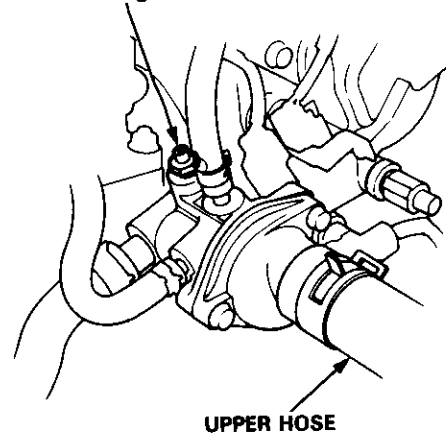

WASHER
Replace.

DRAIN BOLT
60 N·m (6.0 kg-m, 43 lb-ft)
Apply liquid gasket to the bolt threads when installing.

10. With the radiator cap off, start the engine and let it run until warmed up (Radiator fan goes on at least twice). Then, if necessary, add more coolant mix to bring the level back up to the bottom of the filler neck.
11. Put the radiator cap on tightly, then run the engine again and check for leaks.



Cap Testing

1. Remove the radiator cap, wet its seal with engine coolant, then install it on the pressure tester.
2. Apply a pressure of 95–125 kPa (0.95–1.25 kg/cm², 14–18 psi).
3. Check for a drop in pressure.
4. If the pressure drops, replace the cap.

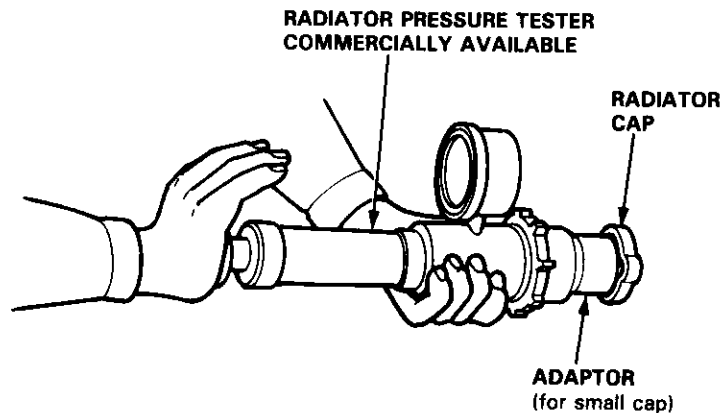

Testing

1. Wait until the engine is cool, then carefully remove the radiator cap and fill the radiator with engine coolant to the top of the filler neck.
2. Attach the pressure tester to the radiator and apply a pressure of 95–125 kPa (0.95–1.25 kg/cm², 14–18 psi).
3. Inspect for engine coolant leaks and a drop in pressure.
4. Remove the teater and reinstall the radiator cap.

NOTE: Check for engine oil in the coolant and/or coolant in engine oil.

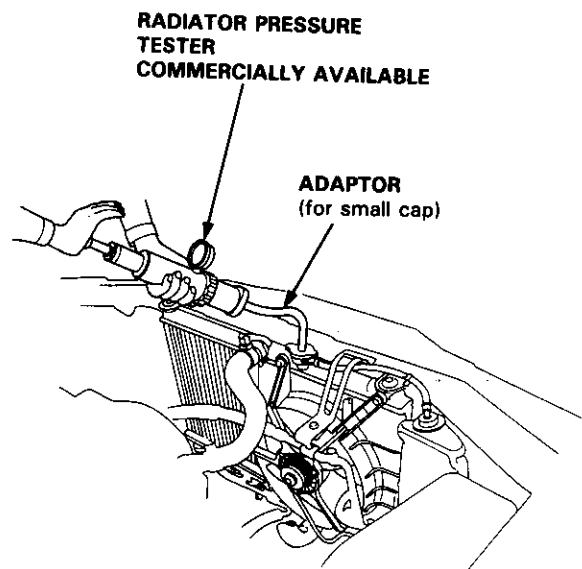

Thermostat

Replacement

NOTE: Use new O-rings when reassembling.

F22A1, H23A1 engines:

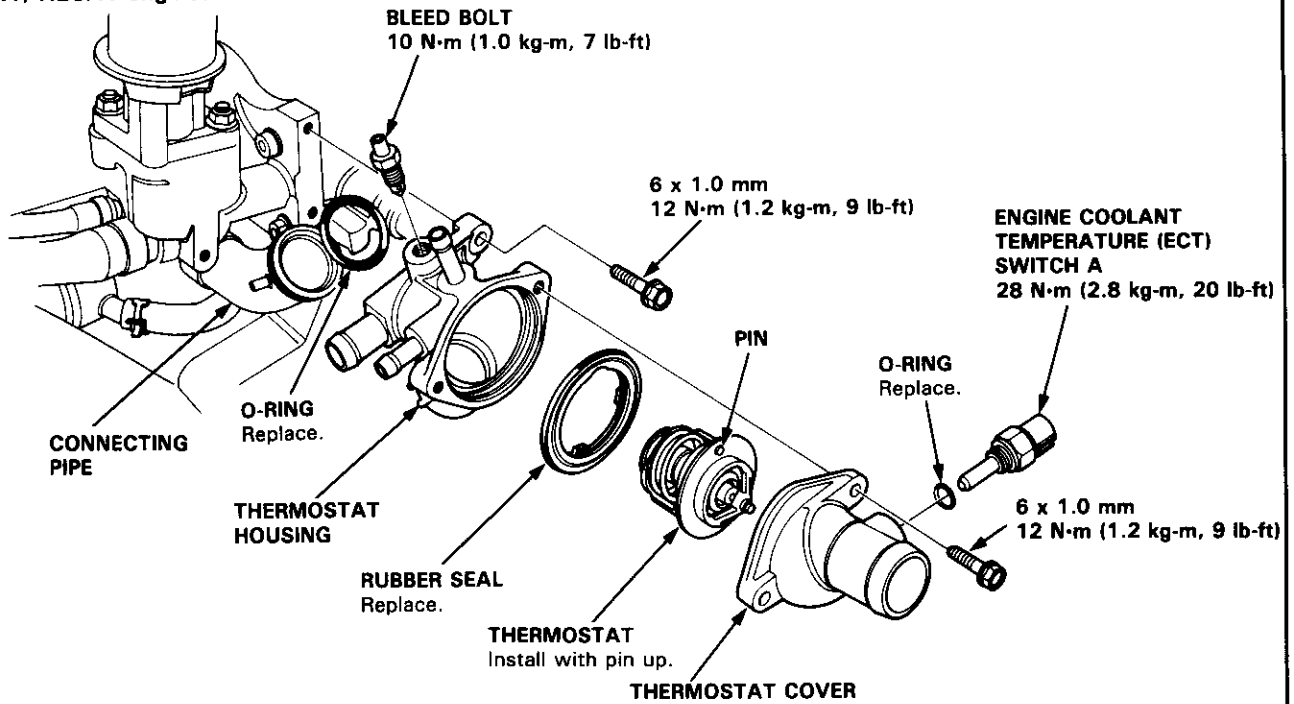

H22A1 engine:

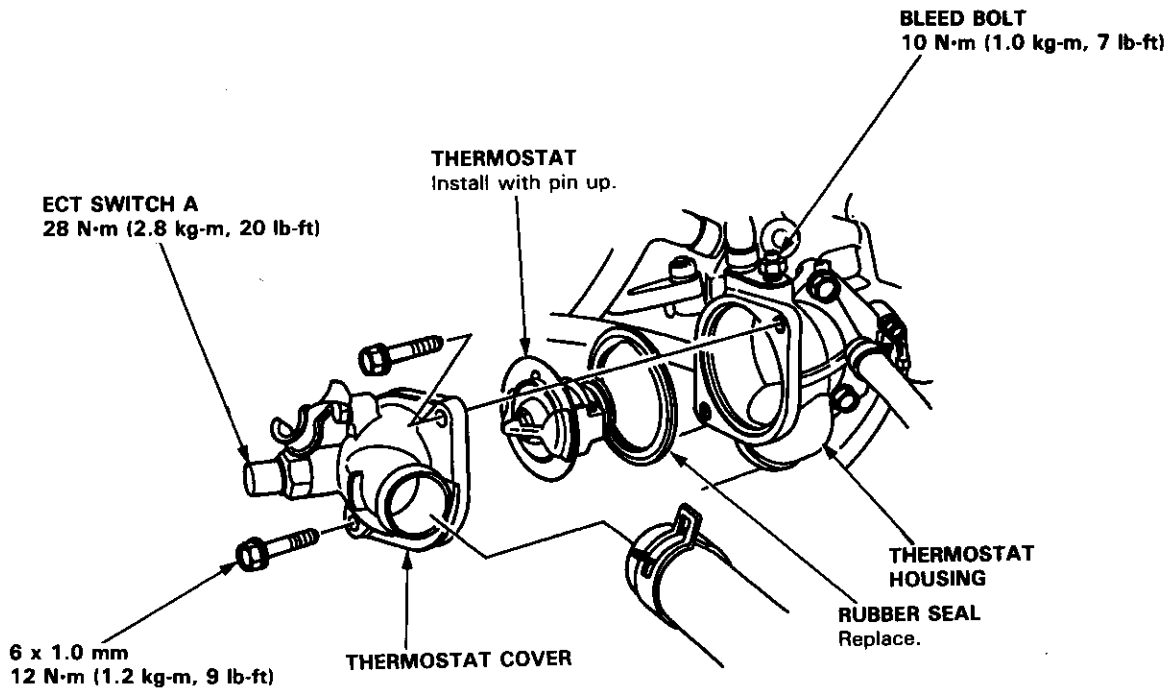



Testing

Replace the thermostat if it is open at room temperature.

To test a closed thermostat:

1. Suspend the thermostat in a container of water as shown.
2. Heat the water and check the temperature with a thermometer. Check the temperature at which the thermostat first opens, and at which it is fully open.

CAUTION: Do not let the thermometer touch the bottom of hot container.

3. Measure lift height of the thermostat when fully open.

STANDARD THERMOSTAT

Lift height: above 8.0 mm (0.31 in.)

Starts opening: 169–176°F (76–80°C)

Fully open: 194°F (90°C)

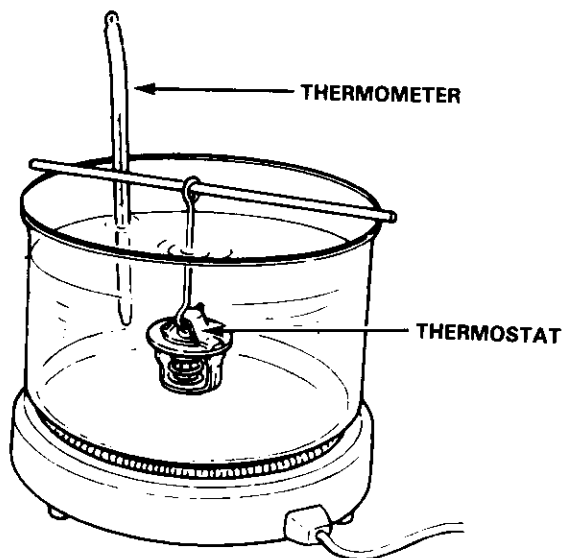

Water Pump

Illustrated Index

NOTE: Use new O-rings when reassembling.

F22A1, H23A1 engines:

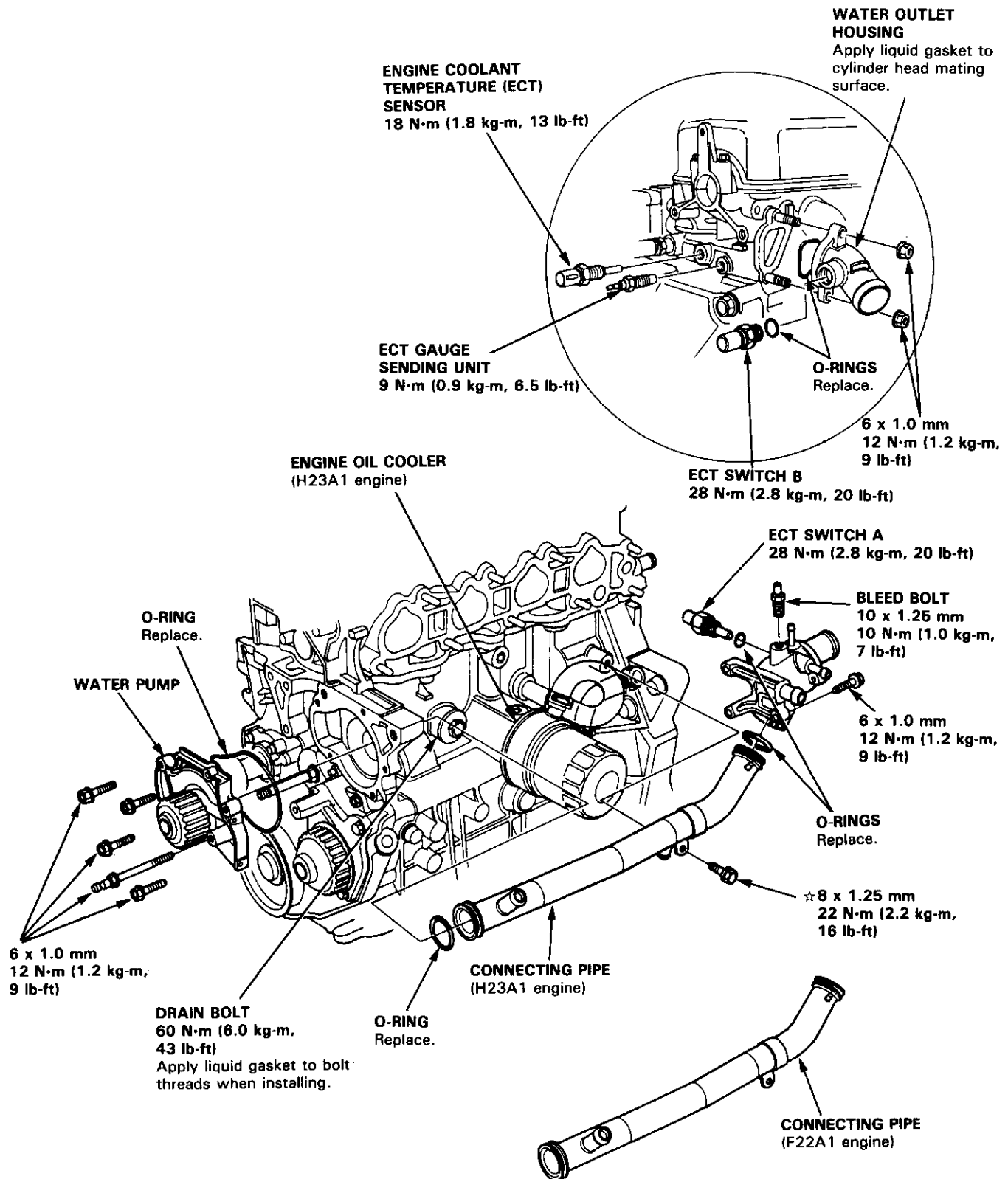

☆: CORROSION RESISTANT BOLT



H22A1 engine:

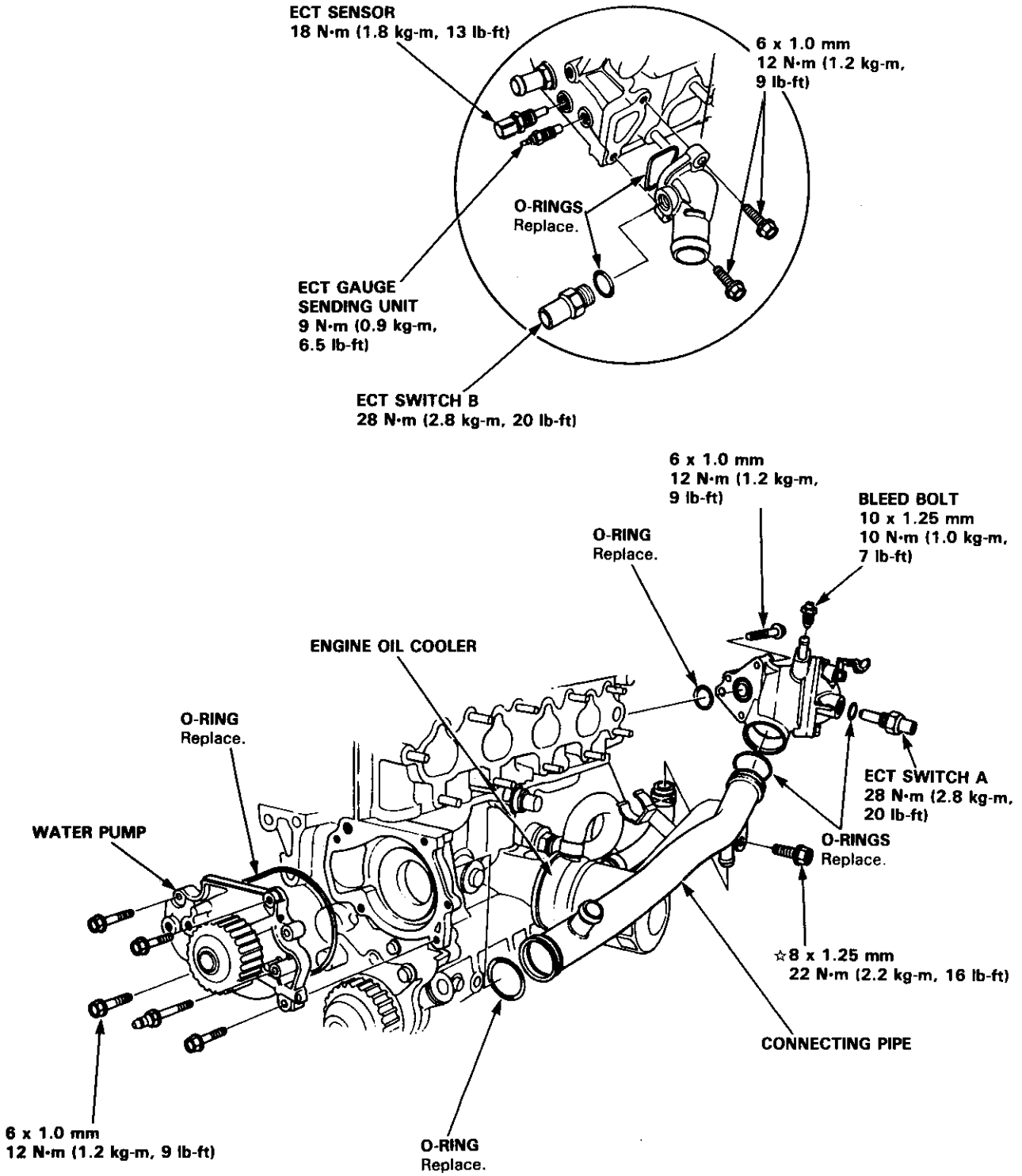

☆: CORROSION RESISTANT BOLT

Water Pump

Inspection

1. Remove the timing balancer belt and timing belt (F22A1 engine: page 6-29, H23A1 engine: page 6-63, H22A1 engine: page 6-109).
2. Check that the water pump pulley turns freely.
3. Check for signs of seal leakage.

NOTE: Small amount of "weeping" from bleed hole is normal.

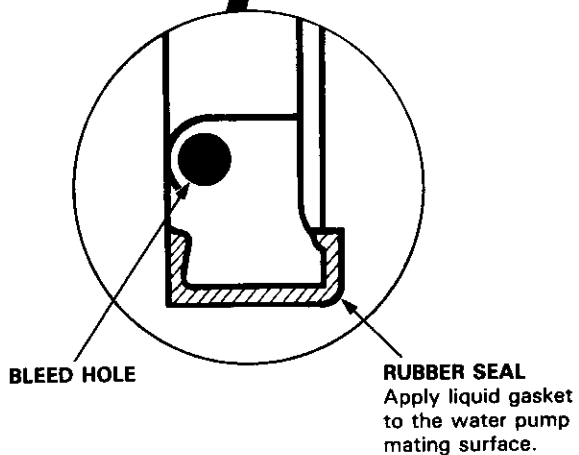
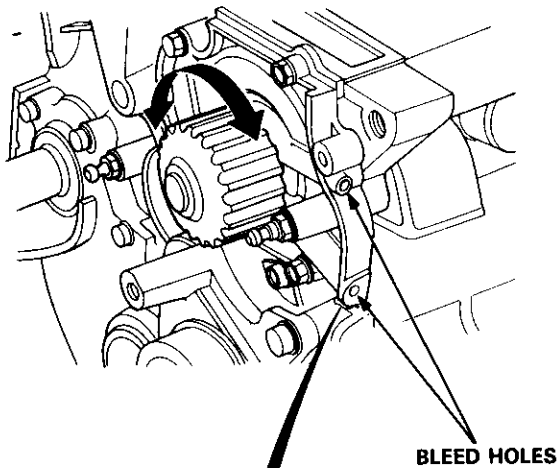

Replacement

1. Remove the timing balancer belt and timing belt (F22A1 engine: page 6-29, H23A1 engine: page 6-63, H22A1 engine: page 6-109).
2. Unscrew the bolts, then remove the water pump.

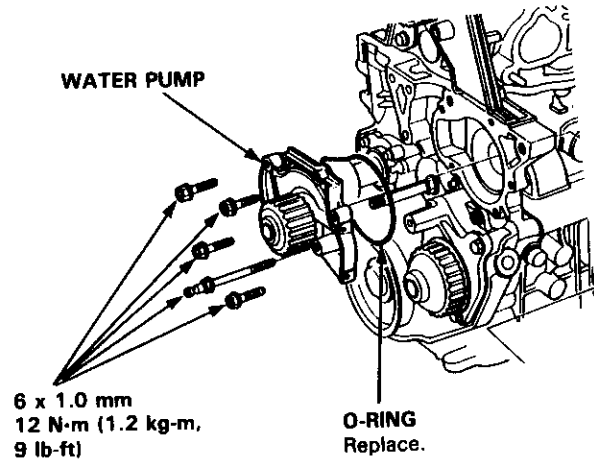

3. Install the water pump in the reverse order of removal.

Fuel and Emissions

Special Tools	11-2	Fuel Supply System	
Component Locations		System Troubleshooting Guide	11-113
Index	11-3	System Description	11-114
System Description		Fuel Pressure	11-114
Vacuum Connections	11-8	Fuel Injectors	11-116
Electrical Connections	11-12	Injector Resistor	11-121
System Connectors	11-20	Fuel Pressure Regulator	11-122
Troubleshooting		Fuel Filter	11-123
Troubleshooting Guide	11-40	Fuel Pump	11-124
Self-diagnostic Procedures	11-42	PGM-FI Main Relay	11-126
How to Read Flowcharts	11-47	Fuel Tank	11-130
PGM-FI System		Intake Air System	
System Description	11-48	System Troubleshooting Guide	11-131
Troubleshooting Flowcharts		System Description	11-132
Engine Will Not Start	11-50	Air Cleaner	11-133
Engine Control Module	11-51	Intake Control System	
Heated Oxygen Sensor	11-56	[Except F22A1 engine(S)]	11-134
Heated Oxygen Sensor Heater	11-58	Throttle Cable	11-138
Fuel Supply System	11-62	Throttle Body	11-139
Manifold Absolute Pressure Sensor	11-64	Intake Air Bypass Control System	
Top Dead Center/Crankshaft Position/ Cylinder Position Sensor	11-70	[Except F22A1 engine(S)]	11-143
Engine Coolant Temperature Sensor	11-72	Intake Manifold [F22A1 engine(S)]	11-148
Throttle Position Sensor	11-74	 	
Intake Air Temperature Sensor	11-76	Emission Control System	
Barometric Pressure Sensor	11-78	System Troubleshooting Guide	11-149
Ignition Output Signal	11-80	System Description	11-150
Vehicle Speed Sensor	11-82	Tailpipe Emission	11-150
Electrical Load Detector	11-84	Three Way Catalytic Converter	11-151
Knock Sensor		Exhaust Gas Recirculation System	11-153
[Except F22A1 engine(S)]	11-88	Positive Crankcase Ventilation System	11-159
A/T FI Signal A/B	11-90	Evaporative Emission Controls	11-160
Idle Control System		 	
System Troubleshooting Guide	11-92	 	
System Description	11-93	 	
Troubleshooting Flowcharts		 	
Idle Air Control Valve	11-96	 	
Air Conditioning Signal	11-98	 	
Alternator FR Signal	11-100	 	
Automatic Transaxle		 	
Gear Position Signal	11-102	 	
Starter Switch Signal	11-104	 	
Brake Switch Signal	11-106	 	
Power Steering Pressure Switch Signal ...	11-108	 	
Fast Idle Thermo Valve	11-109	 	
Starting Air Valve	11-110	 	
Idle Speed Setting	11-111	 	



Special Tools

Ref. No.	Tool Number	Description	Q'ty	Page Reference
①	A973X-041-XXXXX	Vacuum Pump/Gauge	1	11-68, 135, 139, 144, 154, 162, 165
②	KS-AHM-32-003	Digital Multimeter	1	11-45, 58, 63
③	07LAJ-PT3010A	Test Harness	1	11-45
④	07JAZ-001000B	Vacuum/Pressure Gauge 0-4 in. Hg	1	11-164, 165
⑤	07406-0040001	Fuel Pressure Gauge	1	11-115, 122

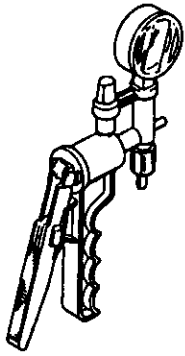

①

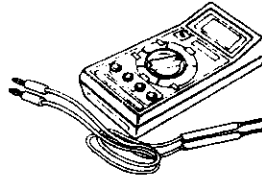

②

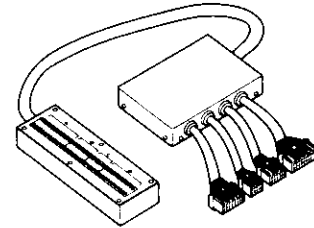

③

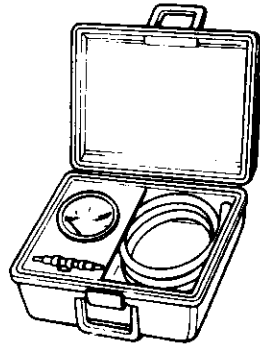

④



⑤

Component Locations



Index

H23A1 engine (USA: Si/Canada: SR):

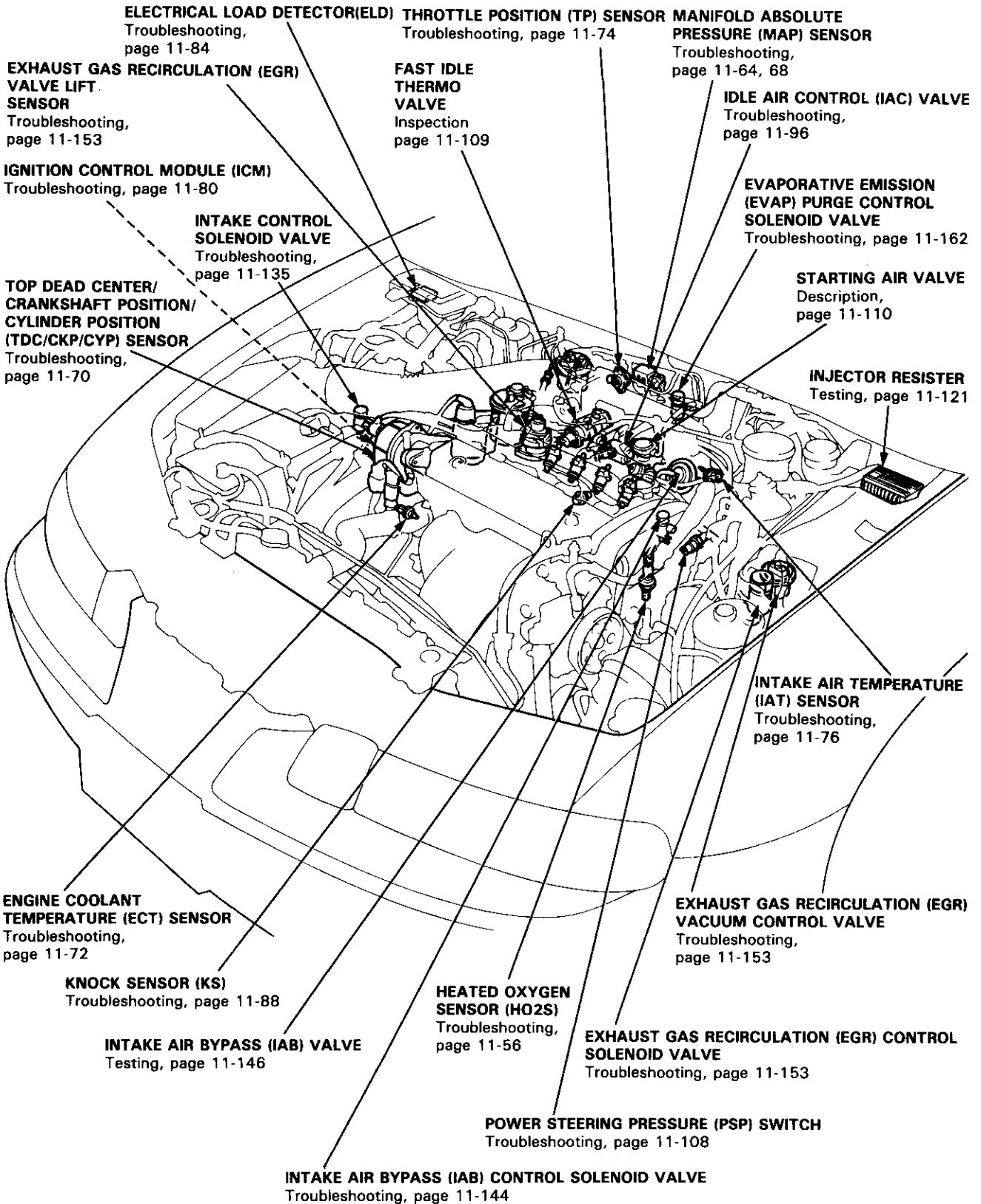

Component Locations

Index

H22A1 engine (USA: Si VTEC/Canada: SR-V)

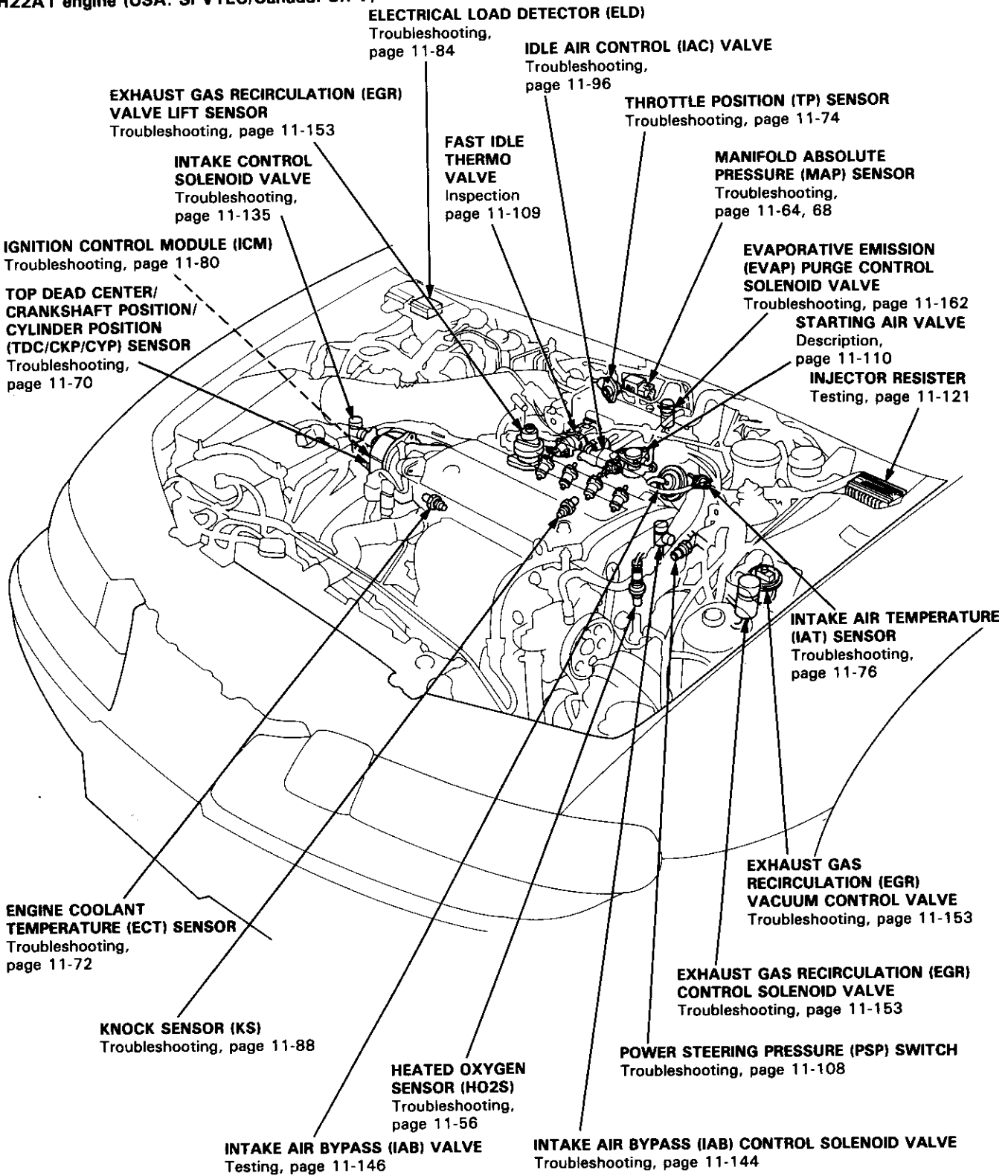



F22A1 engine (S):

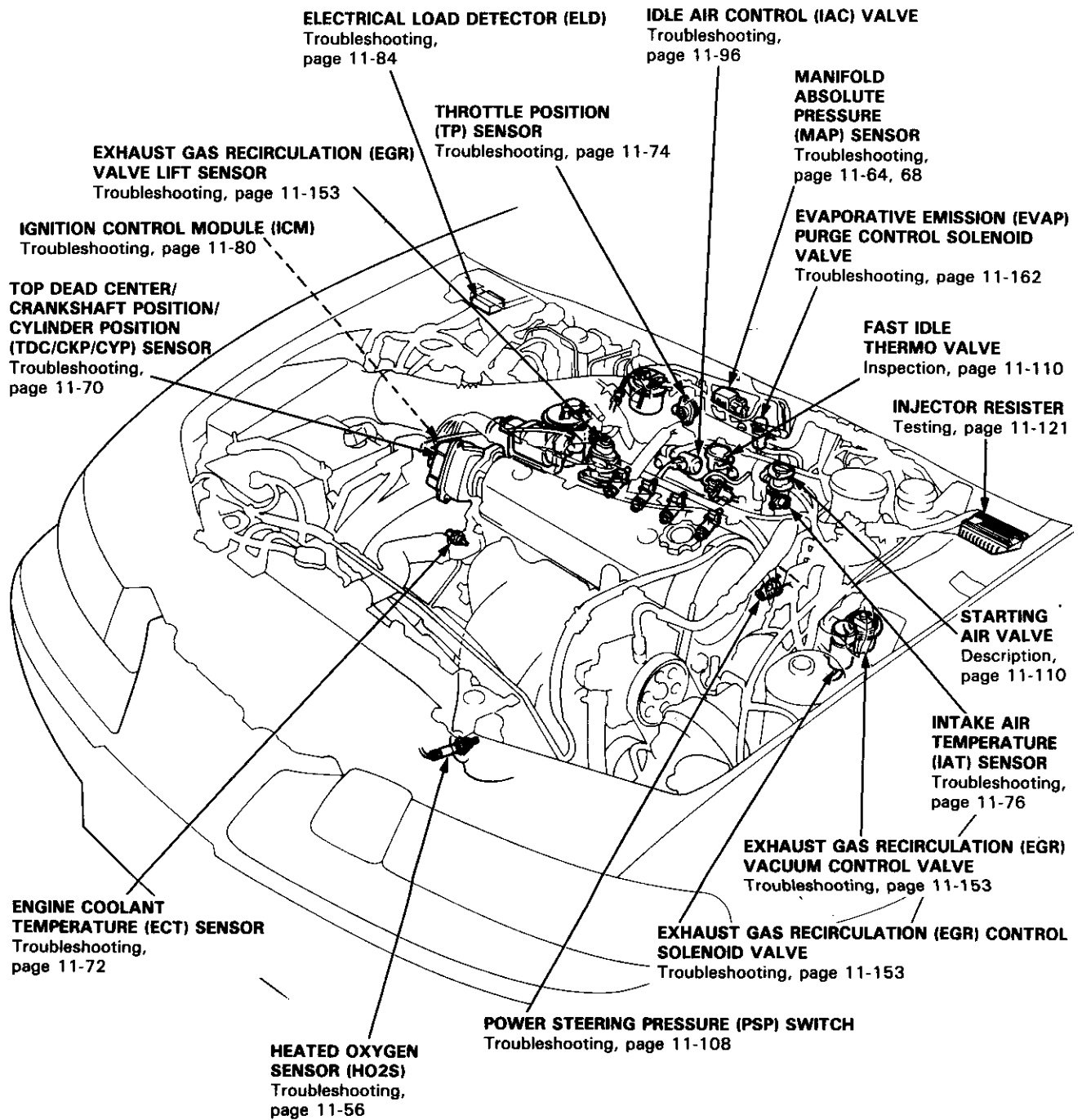

Component Locations

Index

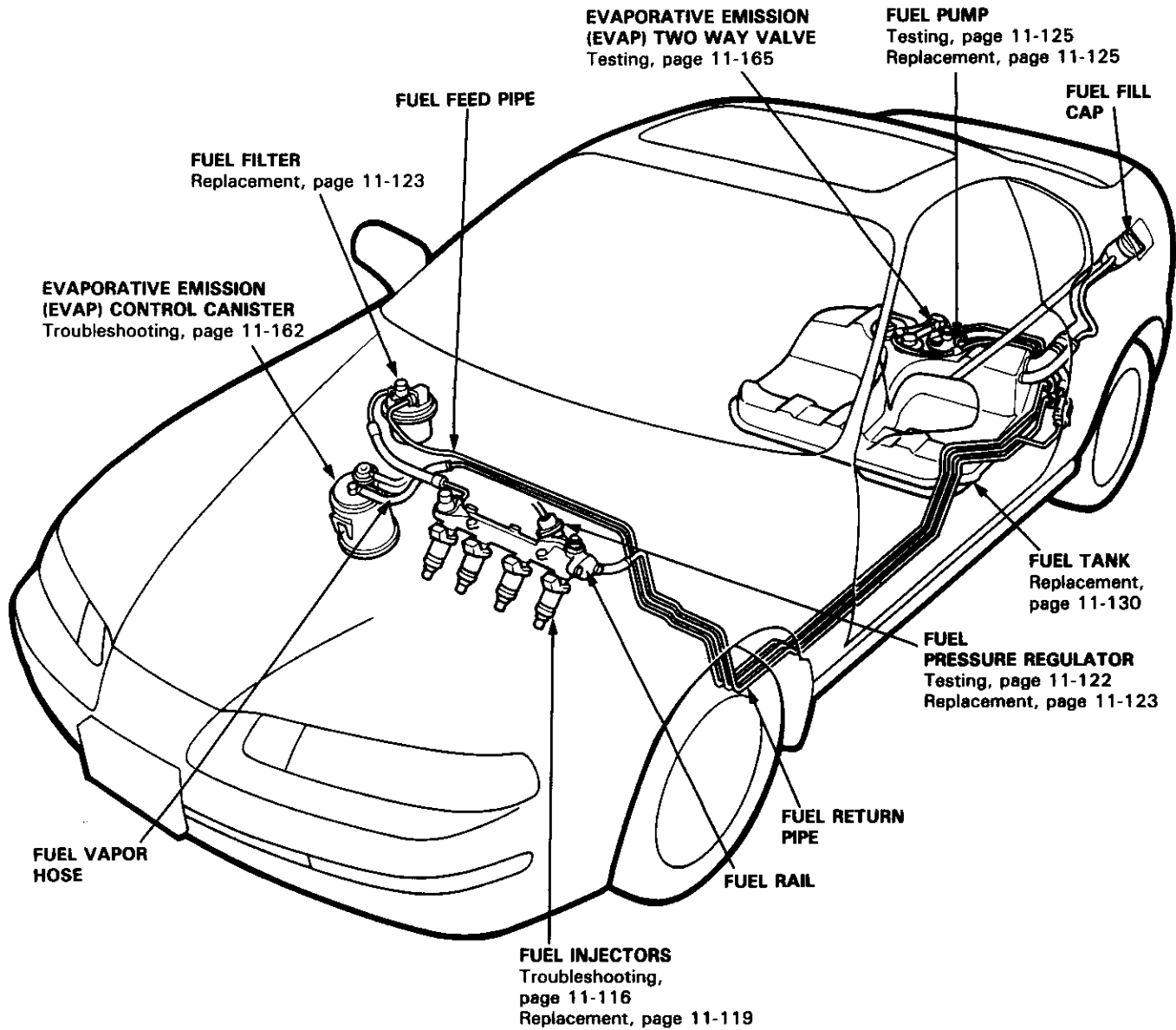

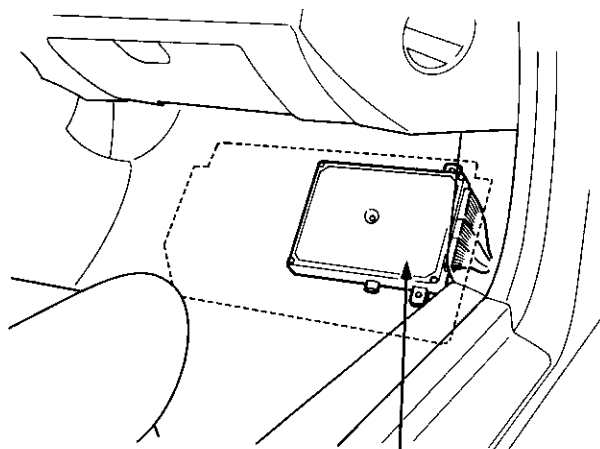
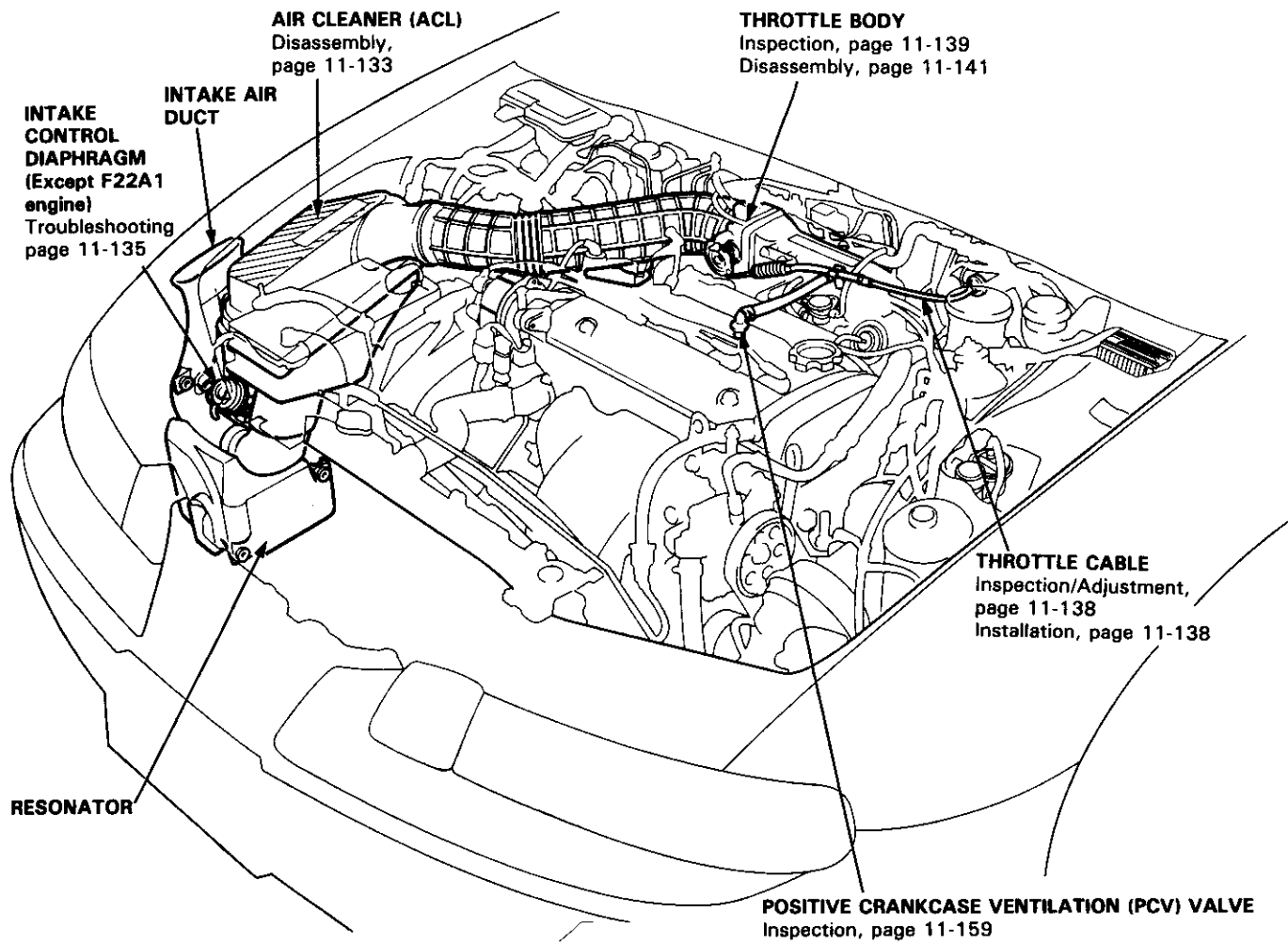

ENGINE CONTROL MODULE (ECM)
Self-diagnostic Procedures, page 11-42
Troubleshooting, page 11-50
Removal, page 11-45

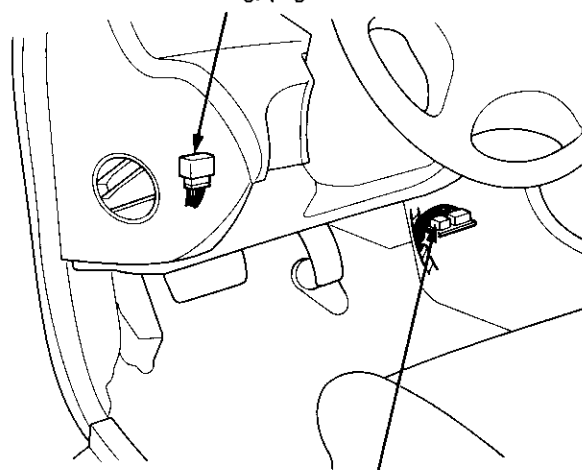

SERVICE CHECK CONNECTOR (2P)
Self-diagnostic Procedures, page 11-42

PGM-FI MAIN RELAY
Relay Testing, page 11-126
Troubleshooting, page 11-128

System Description

Vacuum Connections

H23A1 engine (USA: Si/Canada: SR)

H22A1 engine (USA: Si VTEC/Canada: SR-V)

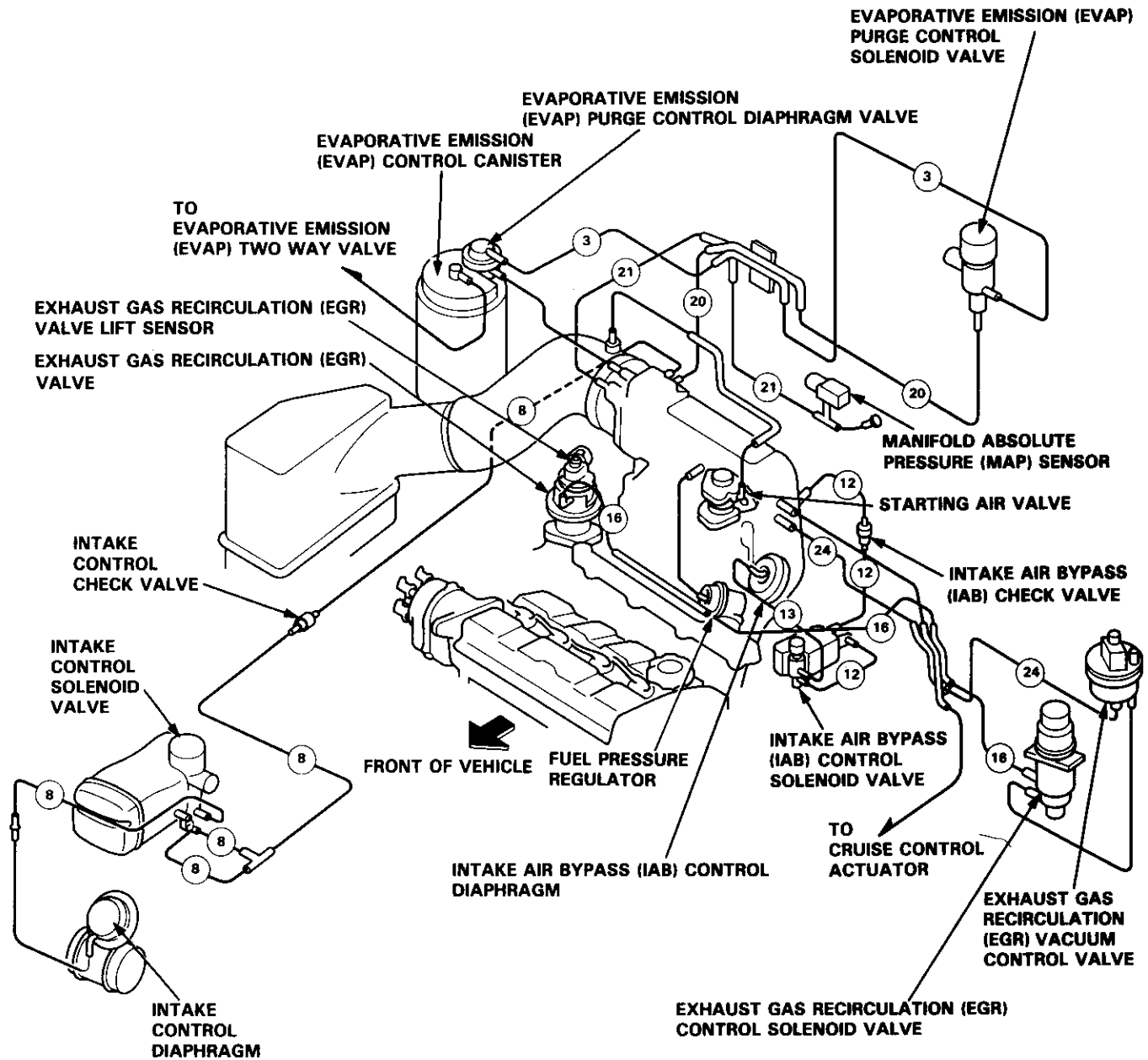



F22A1 engine (S):

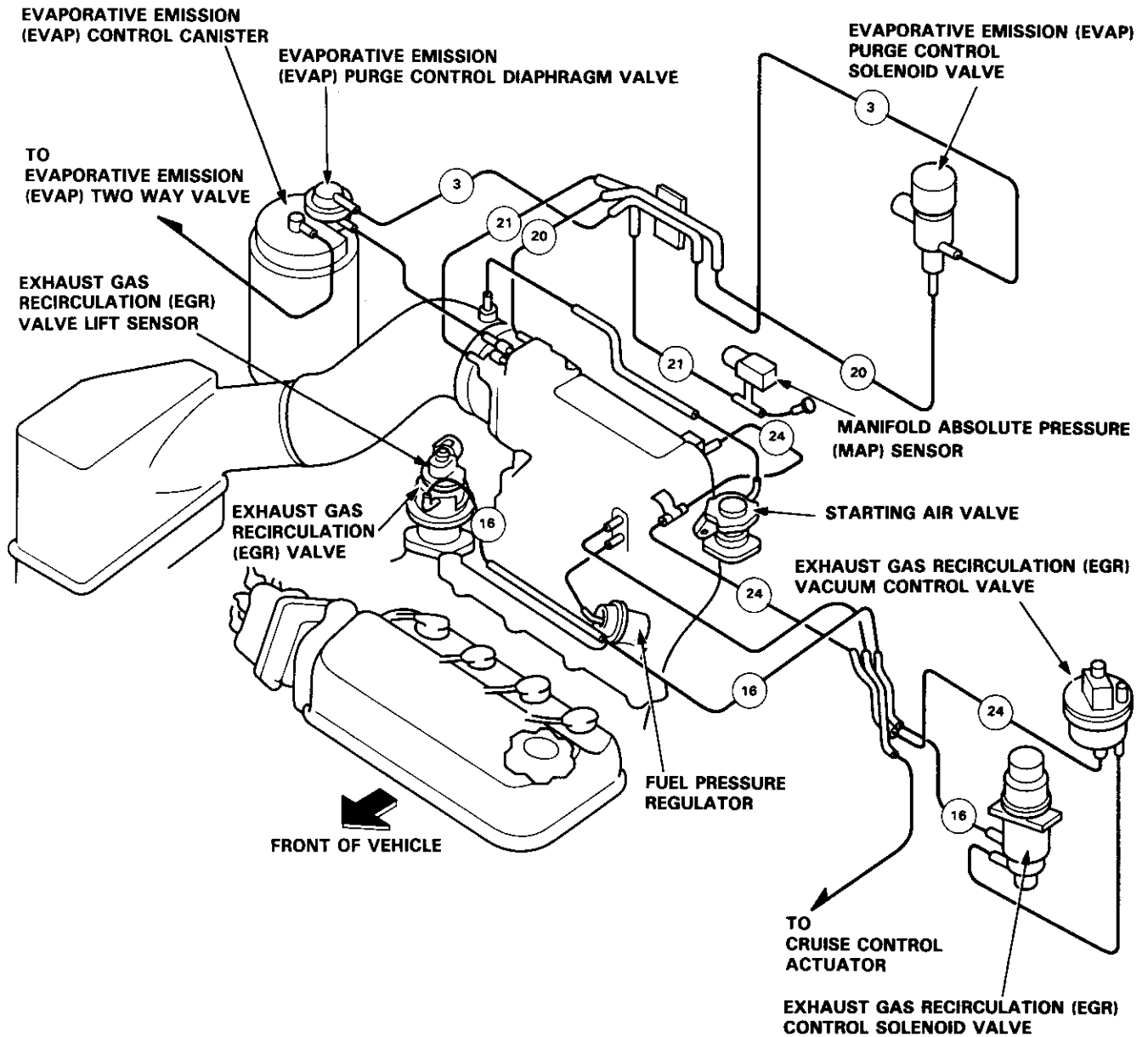

System Description

Vacuum Connections

H23A1 engine (USA: Si/Canada: SR)

H22A1 engine (USA: Si VTEC/Canada: SR-V)

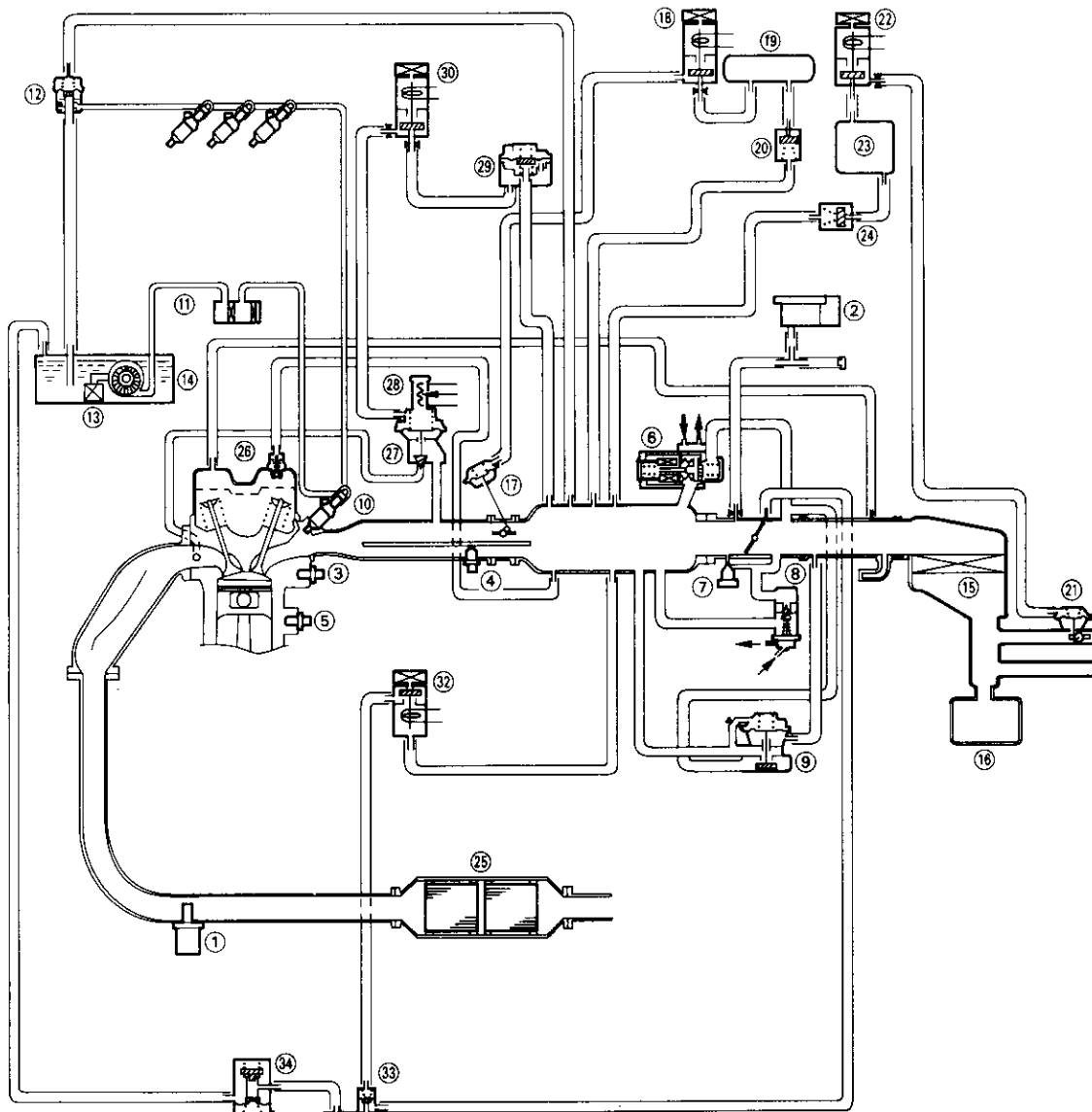

- ① HEATED OXYGEN SENSOR (HO2S)
- ② MANIFOLD ABSOLUTE PRESSURE (MAP) SENSOR
- ③ ENGINE COOLANT TEMPERATURE (ECT) SENSOR
- ④ INTAKE AIR TEMPERATURE (IAT) SENSOR
- ⑤ KNOCK SENSOR (KS)
- ⑥ IDLE AIR CONTROL (IAC) VALVE
- ⑦ IDLE ADJUSTING SCREW
- ⑧ FAST IDLE THERMO VALVE
- ⑨ STARTING AIR VALVE
- ⑩ FUEL INJECTOR
- ⑪ FUEL FILTER
- ⑫ FUEL PRESSURE REGULATOR
- ⑬ FUEL PUMP
- ⑭ FUEL TANK
- ⑮ AIR CLEANER
- ⑯ RESONATOR
- ⑰ INTAKE AIR BYPASS (IAB) CONTROL DIAPHRAGM
- ⑱ INTAKE AIR BYPASS (IAB) CONTROL SOLENOID VALVE

- ⑲ INTAKE AIR BYPASS (IAB) VACUUM TANK
- ⑳ INTAKE AIR BYPASS (IAB) CHECK VALVE
- ㉑ INTAKE CONTROL DIAPHRAGM
- ㉒ INTAKE CONTROL SOLENOID VALVE
- ㉓ INTAKE CONTROL VACUUM TANK
- ㉔ INTAKE CONTROL CHECK VALVE
- ㉕ THREE WAY CATALYTIC CONVERTER (TWC)
- ㉖ POSITIVE CRANKCASE VENTILATION (PCV) VALVE
- ㉗ EXHAUST GAS RECIRCULATION (EGR) VALVE
- ㉘ EXHAUST GAS RECIRCULATION (EGR) VALVE LIFT SENSOR
- ㉙ EXHAUST GAS RECIRCULATION (EGR) VACUUM CONTROL VALVE
- ㉚ EXHAUST GAS RECIRCULATION (EGR) CONTROL SOLENOID VALVE
- ㉛ EVAPORATIVE EMISSION (EVAP) CONTROL CANISTER
- ㉜ EVAPORATIVE EMISSION (EVAP) PURGE CONTROL SOLENOID VALVE
- ㉝ EVAPORATIVE EMISSION (EVAP) PURGE CONTROL DIAPHRAGM VALVE
- ㉞ EVAPORATIVE EMISSION (EVAP) TWO WAY VALVE



F22A1 engine (S):

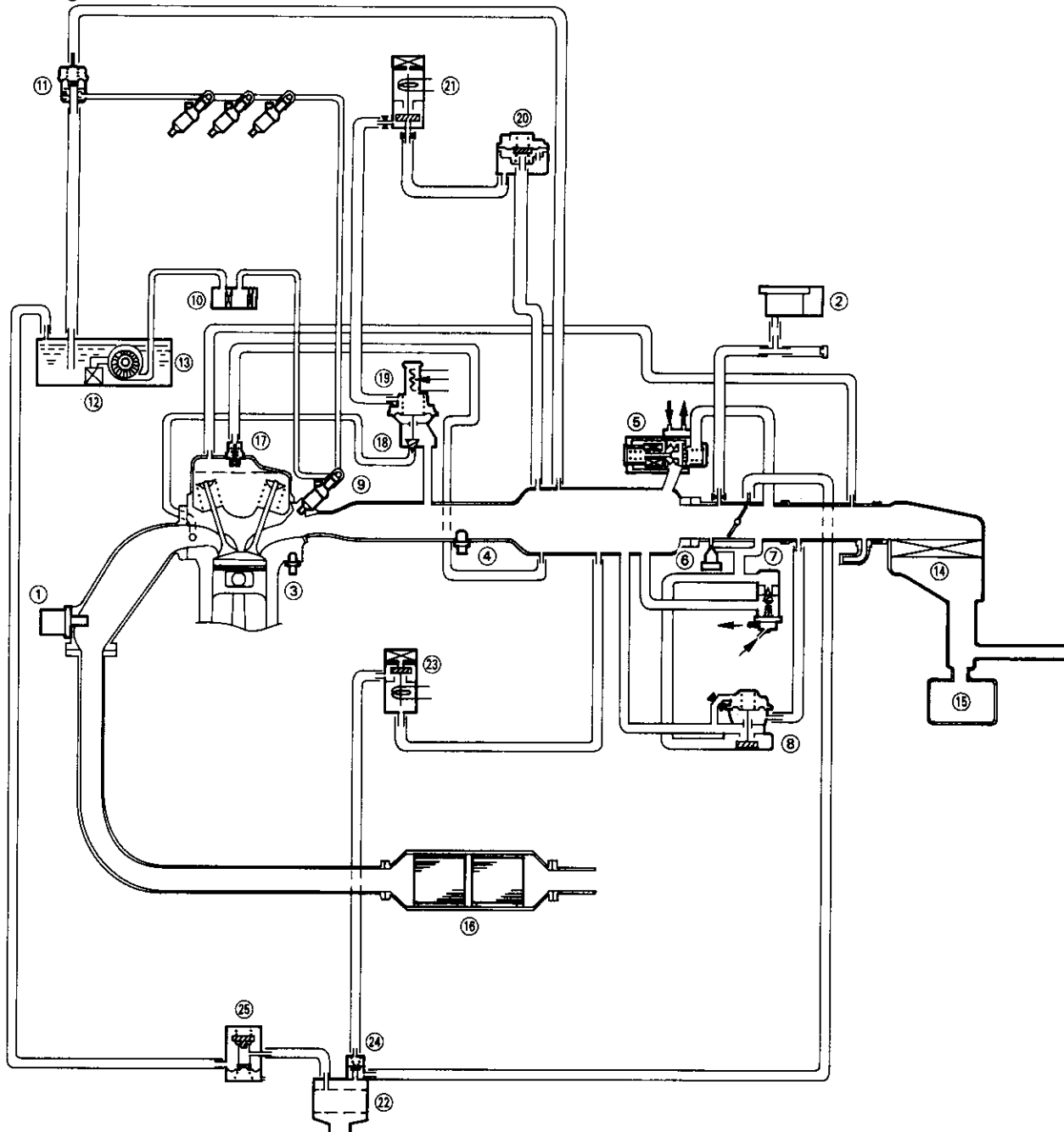

- ① HEATED OXYGEN SENSOR (HO2S)
- ② MANIFOLD ABSOLUTE PRESSURE (MAP) SENSOR
- ③ ENGINE COOLANT TEMPERATURE (ECT) SENSOR
- ④ INTAKE AIR TEMPERATURE (IAT) SENSOR
- ⑤ IDLE AIR CONTROL (IAC) VALVE
- ⑥ IDLE ADJUSTING SCREW
- ⑦ FAST IDLE THERMO VALVE
- ⑧ STARTING AIR VALVE
- ⑨ FUEL INJECTOR
- ⑩ FUEL FILTER
- ⑪ FUEL PRESSURE REGULATOR
- ⑫ FUEL PUMP
- ⑬ FUEL TANK
- ⑭ AIR CLEANER
- ⑮ RESONATOR

- ⑯ THREE WAY CATALYTIC CONVERTER (TWC)
- ⑰ POSITIVE CRANKCASE VENTILATION (PCV) VALVE
- ⑱ EXHAUST GAS RECIRCULATION (EGR) VALVE
- ⑲ EXHAUST GAS RECIRCULATION (EGR) VALVE LIFT SENSOR
- ⑳ EXHAUST GAS RECIRCULATION (EGR) VACUUM CONTROL VALVE
- ㉑ EXHAUST GAS RECIRCULATION (EGR) CONTROL SOLENOID VALVE
- ㉒ EVAPORATIVE EMISSION (EVAP) CONTROL CANISTER
- ㉓ EVAPORATIVE EMISSION (EVAP) PURGE CONTROL SOLENOID VALVE
- ㉔ EVAPORATIVE EMISSION (EVAP) PURGE CONTROL DIAPHRAGM VALVE
- ㉕ EVAPORATIVE EMISSION (EVAP) TWO WAY VALVE

System Description

Electrical Connections

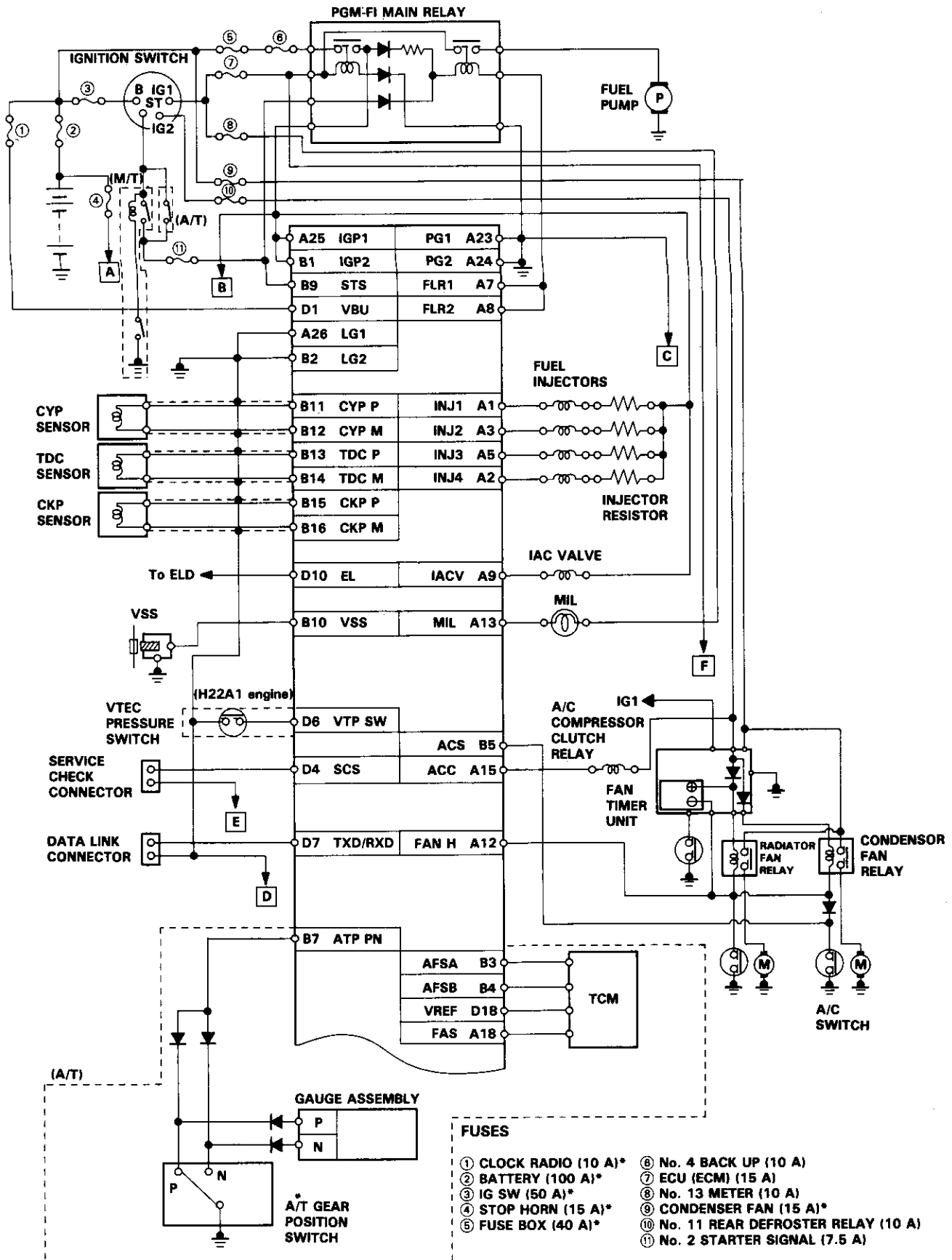

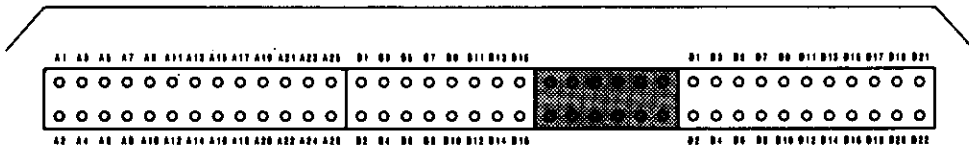
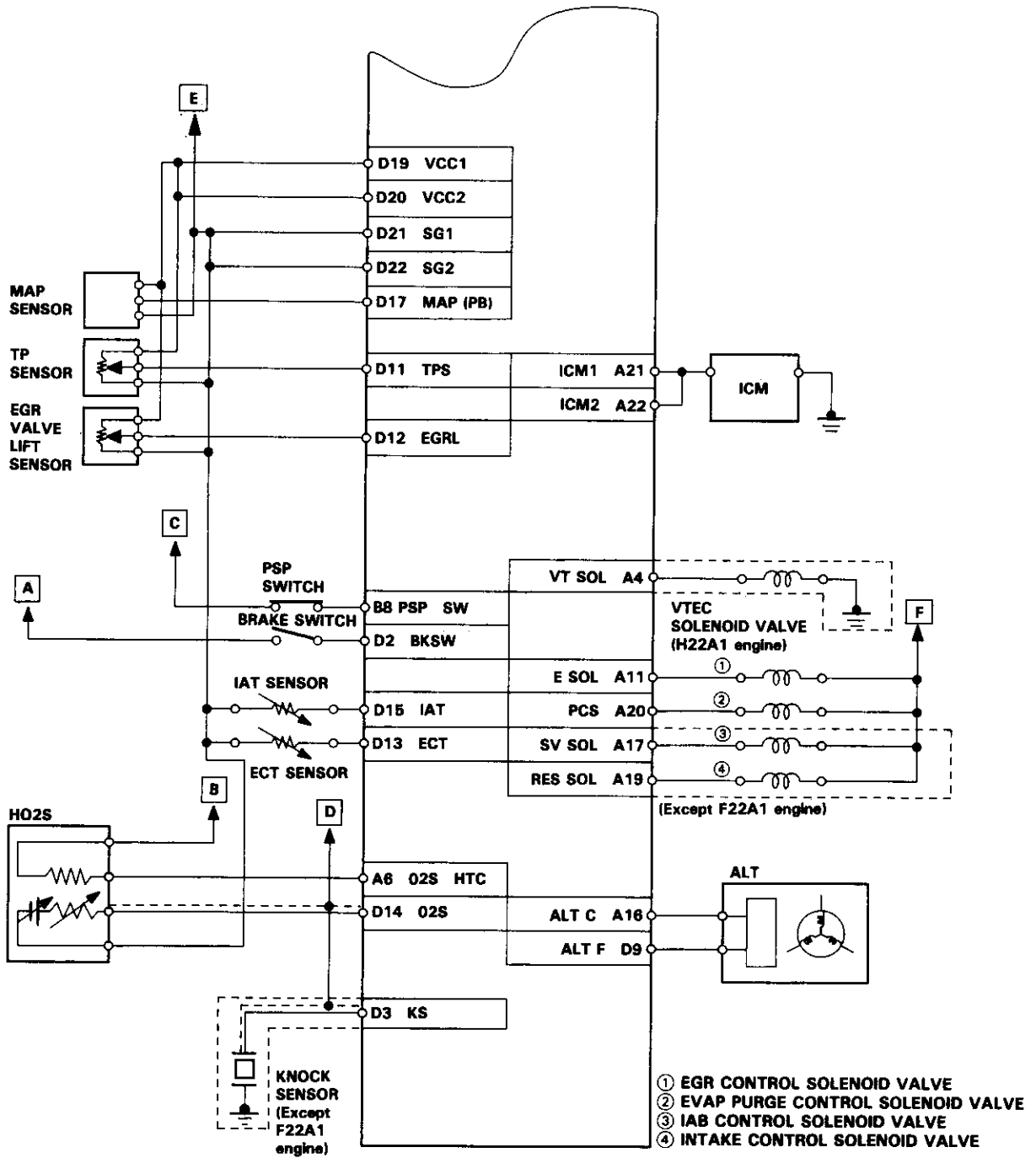

TERMINAL LOCATIONS

(cont'd)

System Description

Electrical Connections (cont'd)

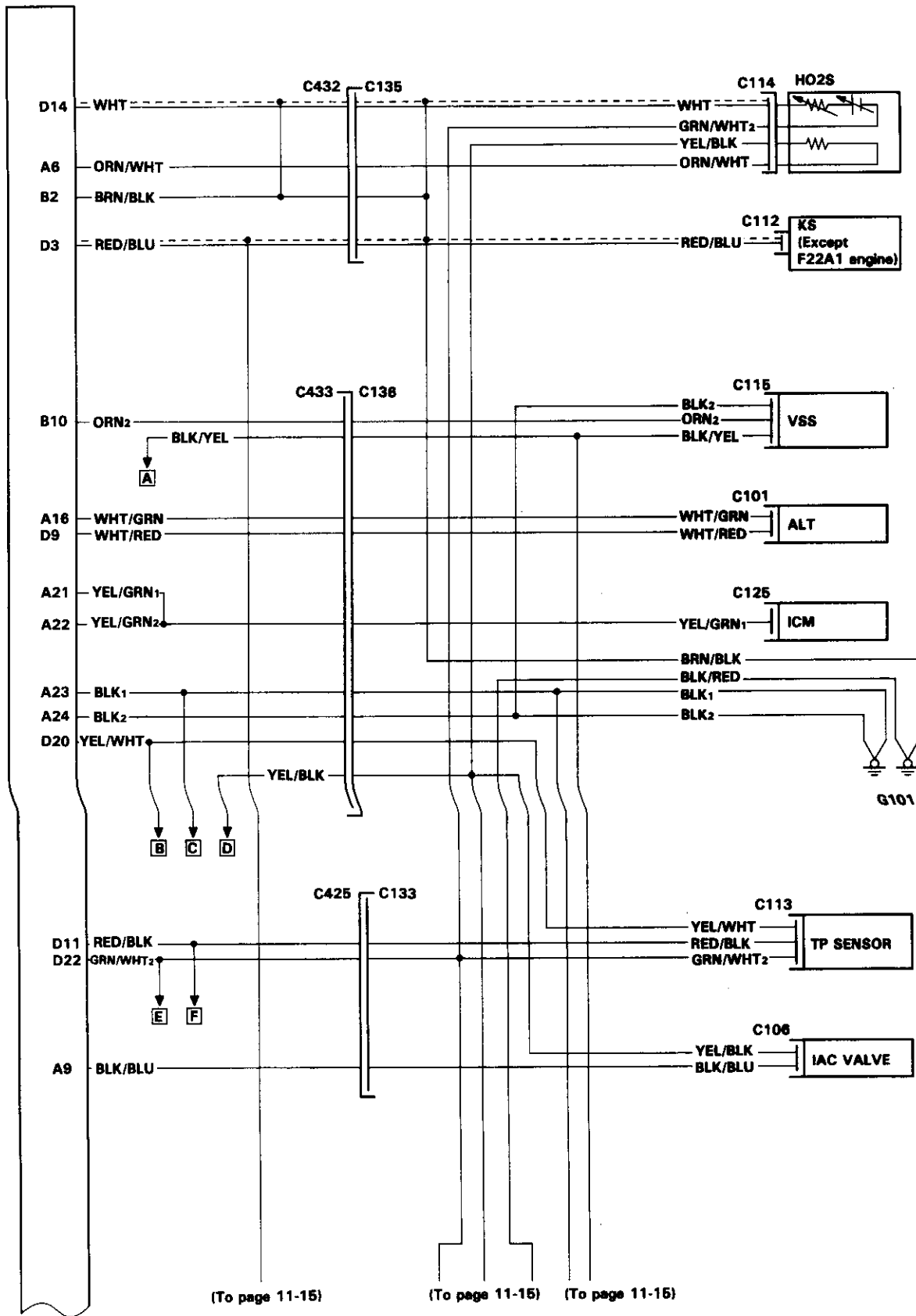

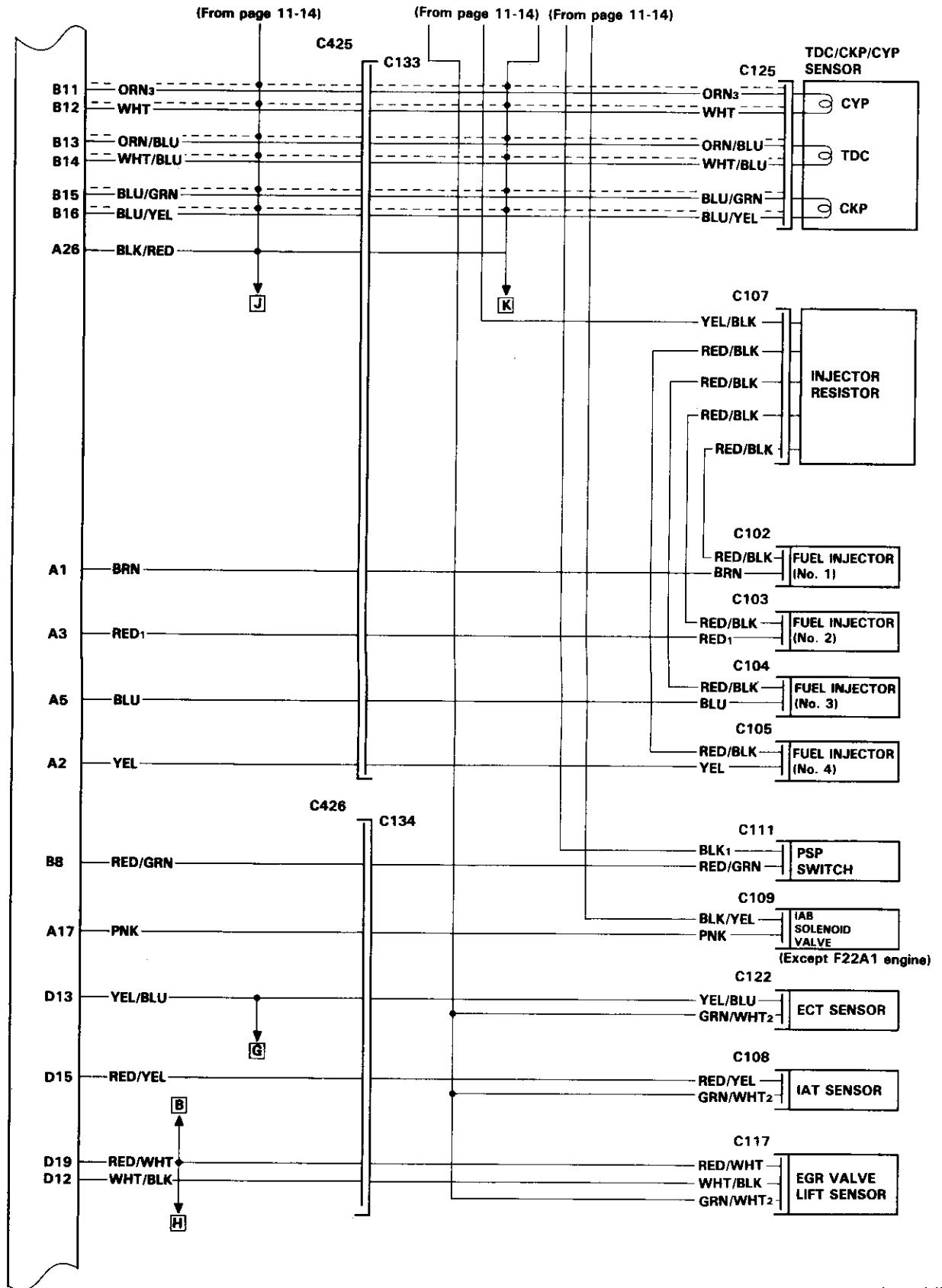

(cont'd)

System Description

Electrical Connections (cont'd)

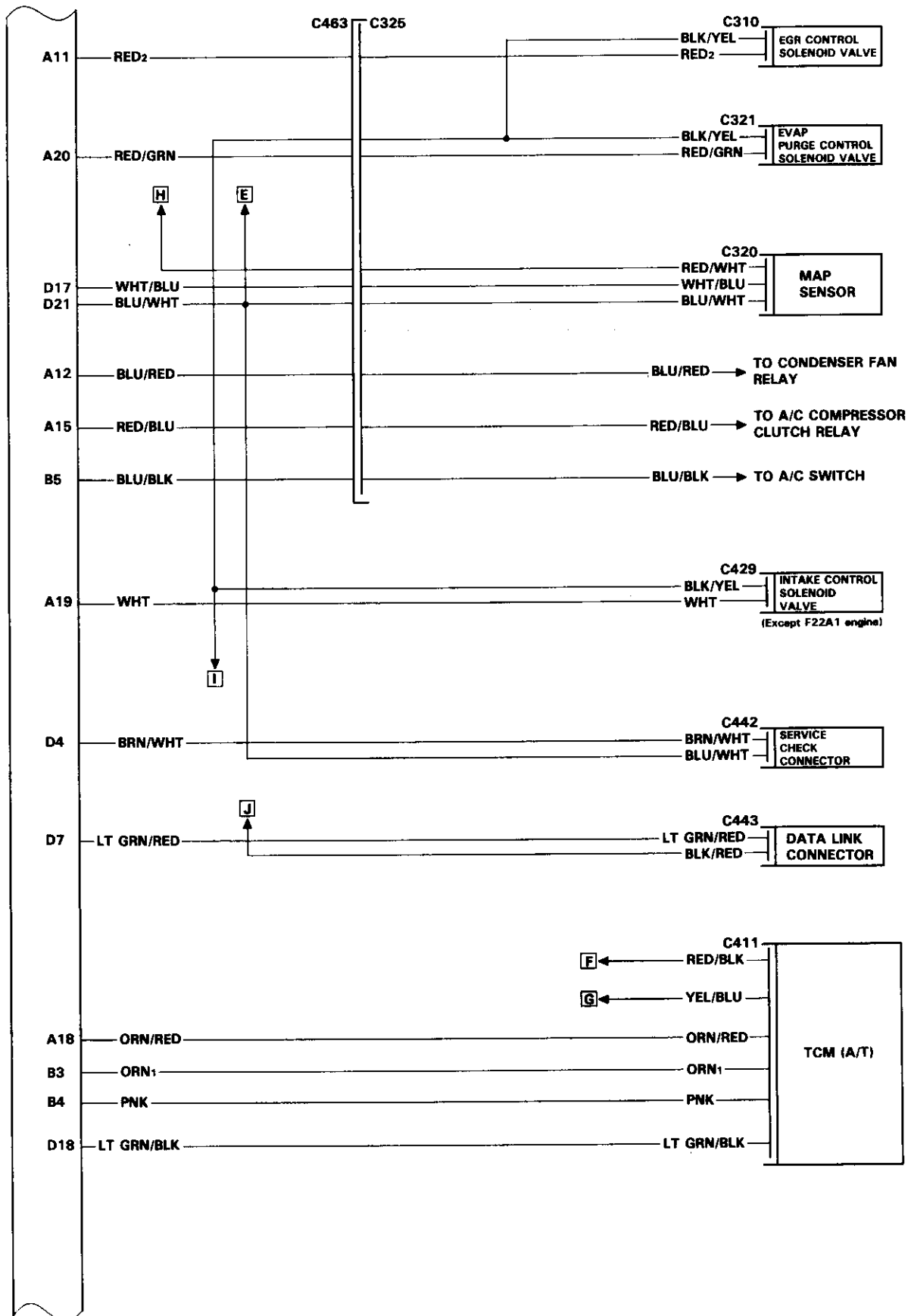

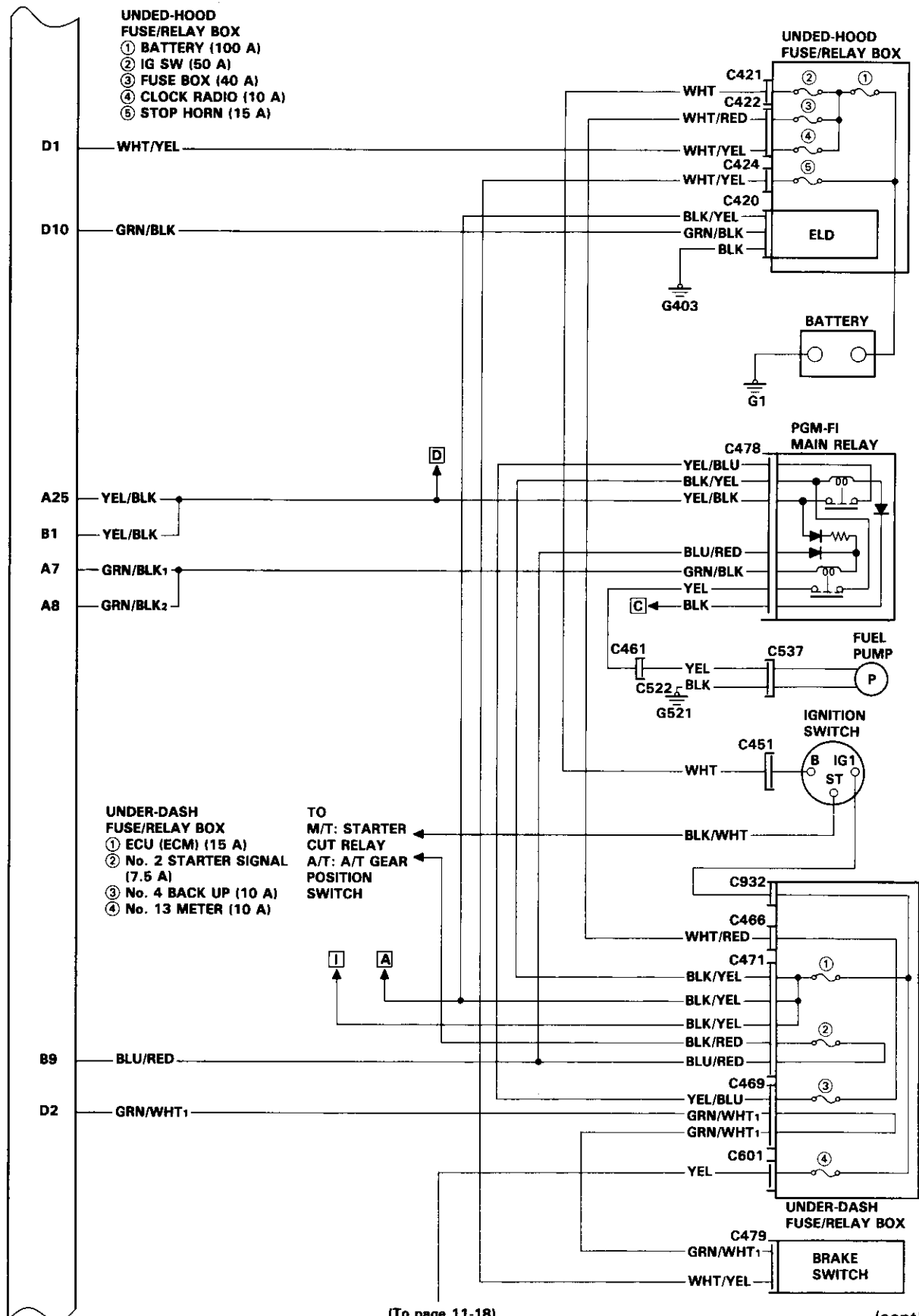

(To page 11-18)

(cont'd)

System Description

Electrical Connections (cont'd)

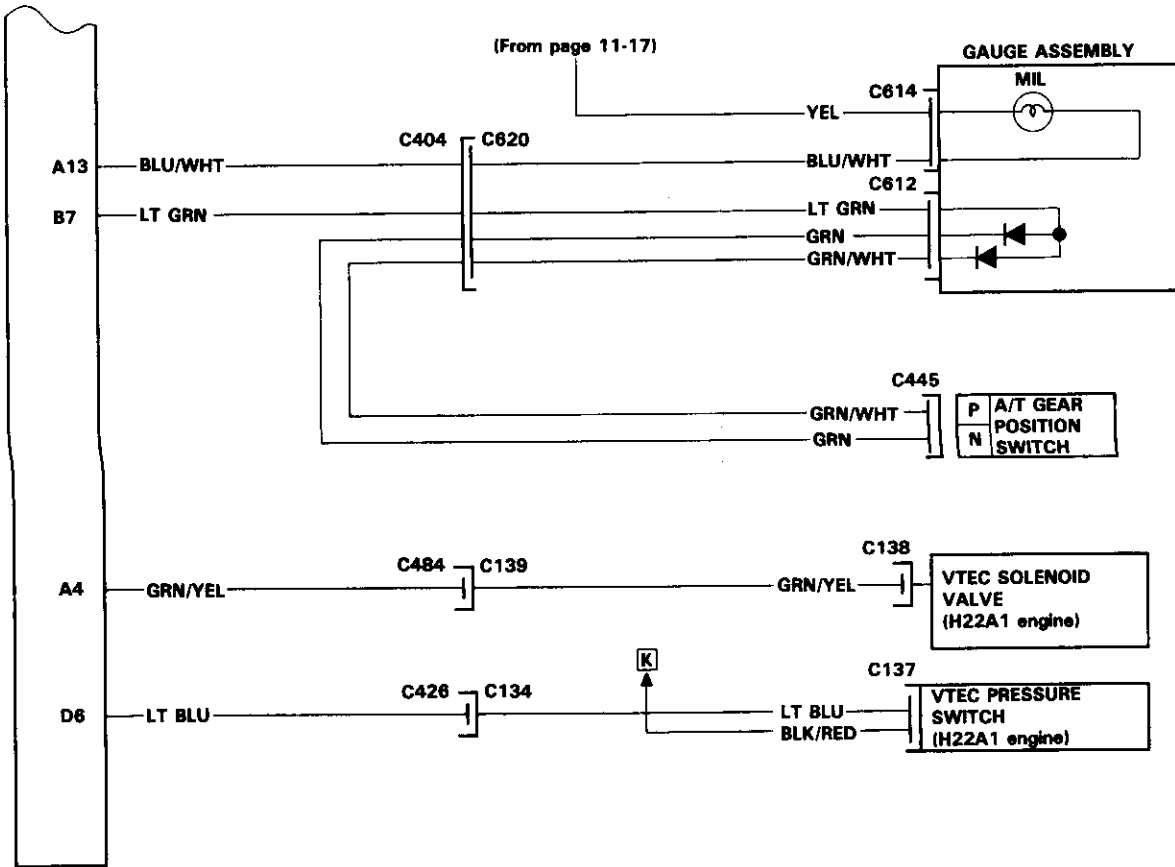

System Description

System Connectors [Engine Compartment]

H22A1 engine (USA: Si VTEC/Canada: SR-V)
H23A1 engine (USA: Si/Canada: SR)

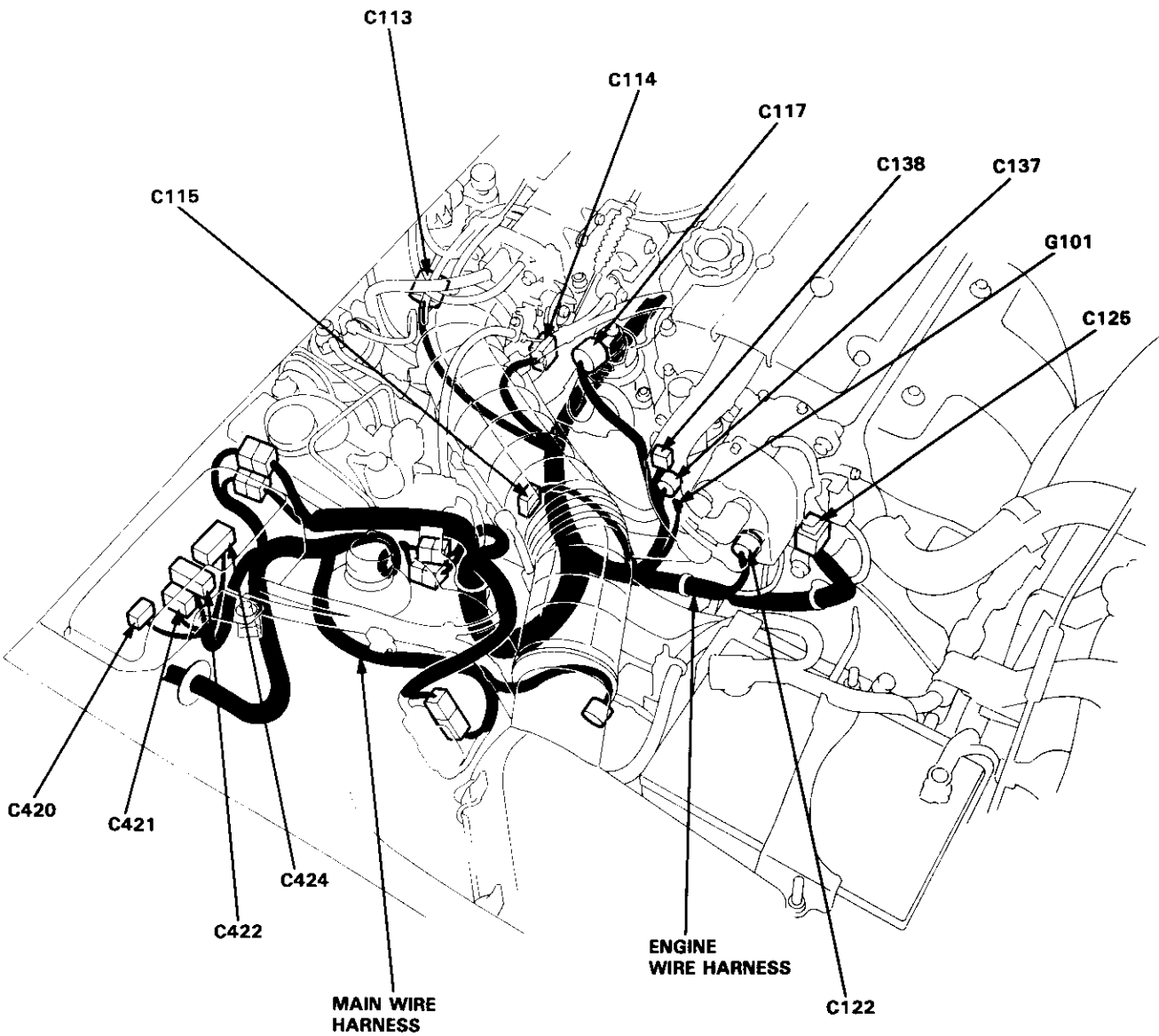



C113

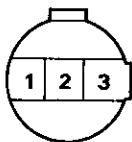

①	YEL/WHT
②	RED/BLK
③	GRN/WHT ²

C114

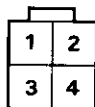

①	GRN/WHT ²
②	WHT
③	ORN/WHT
④	YEL/BLK

C115

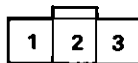

①	ORN ²
②	BLK/YEL
③	BLK ²

C117



①	RED/WHT
②	GRN/WHT ²
③	WHT/BLK

C122



①	GRN/WHT ²
②	YEL/BLU

C125

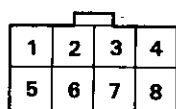

①	ORN ³
②	ORN/BLU
③	BLU/GRN
④	YEL/GRN ¹
⑤	WHT
⑥	WHT/BLU
⑦	BLU/YEL
⑧	BLU

C137 (H22A1 engine)



①	LT BLU
②	BLK/RED

C138 (H22A1 engine)



①	GRN/YEL
---	---------

C420

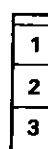

①	BLK
②	GRN/BLK
③	BLK/YEL

C421

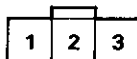

1	WHT
2	BLK/GRN
③	WHT

C422

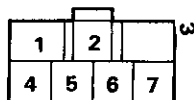

1	WHT/BLU (ABS)
2	WHT/BLU
③	WHT/RED
4	BLK
5	BLU/RED
6	WHT (ABS)
⑦	WHT/YEL

C424

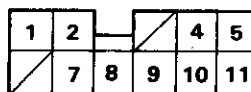

1	RED/BLU	6	---
2	WHT/GRN (ABS)	⑦	WHT/YEL
3	---	8	WHT/BLK (ABS)
4	RED/GRN	9	BLK/YEL (ABS)
5	WHT/GRN	10	WHT (ABS)
		11	WHT/BLU

NOTE: Different wires with the same color have been given a number suffix to distinguish them (for example YEL/BLK₁ and YEL/BLK₂ are not the same).

○: Related to Fuel and Emissions System.

(cont'd)

System Description

System Connectors [Engine Compartment] (cont'd)

H22A1 engine (USA: Si VTEC/Canada: SR-V)

H23A1 engine (USA: Si/Canada: SR)

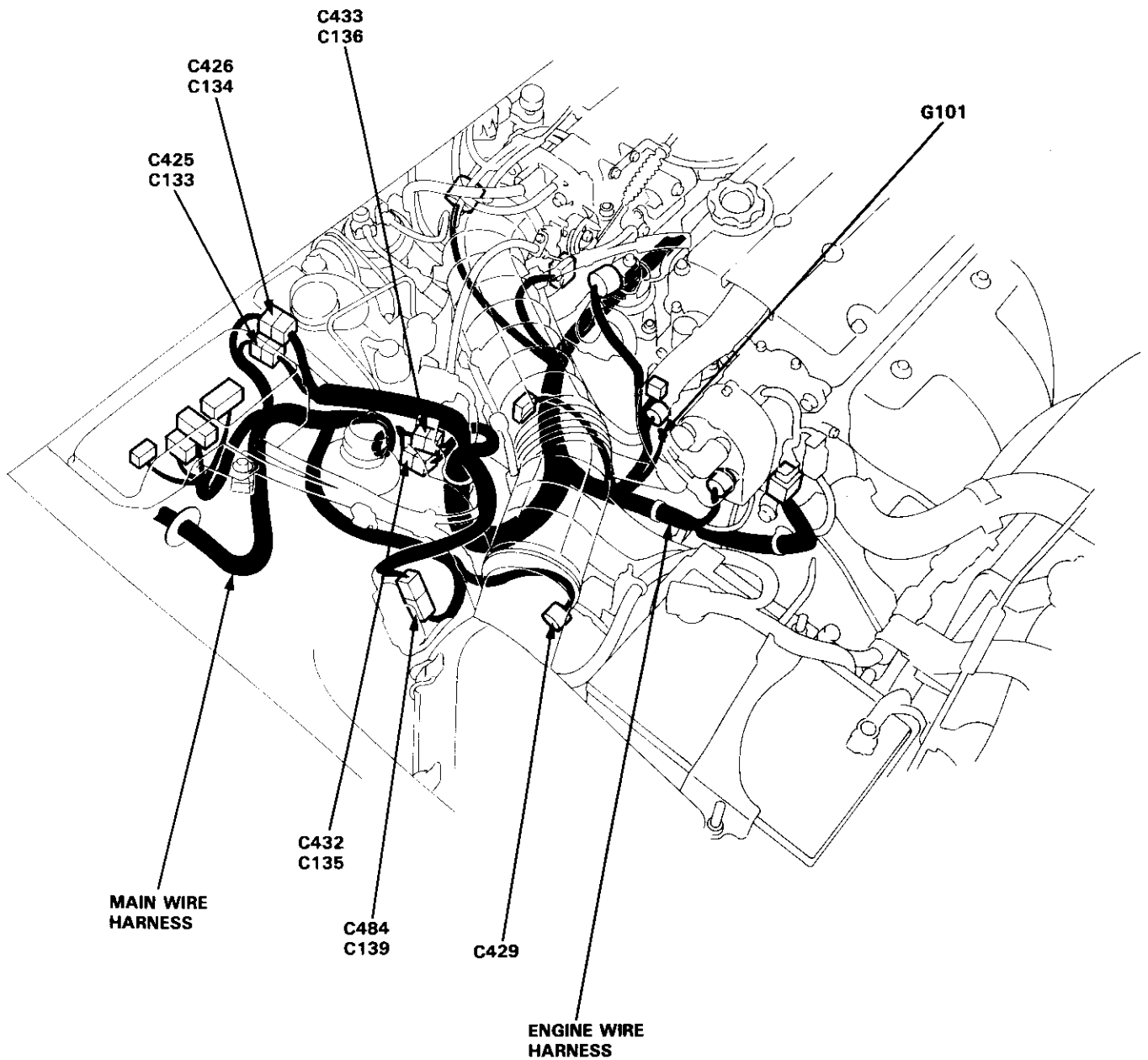



C425

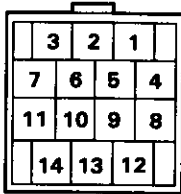

① WHT	⑥ BLK/BLU
② WHT/BLU	⑦ RED/BLK
③ BLU/YEL	⑩ GRN/WHT ²
④ BRN	⑪ BLK/RED
⑤ RED ¹	⑫ ORN ³
⑧ BLU	⑬ ORN/BLU
⑨ YEL	⑭ BLU/GRN

C426

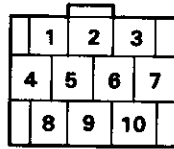

① RED/YEL	⑥ WHT/BLK
2 GRN/BLK	⑧ WHT/YEL
3 WHT/BLK (A/T)	⑦ YEL/BLU
4 YEL	⑨ LT BLU (H22A1 engine)
⑤ RED/WHT (A/T)	⑩ RED/GRN
④ RED/WHT	⑪ PNK

C429



① BLK/YEL
② WHT

C432 (M/T)

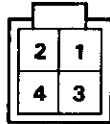

① BRN/BLK
② WHT
③ ORN/WHT
④ RED/BLU

C432 (A/T)

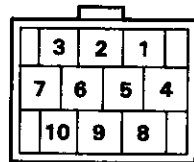

1 BLU/GRN	⑧ BRN/BLK
2 BLU/YEL	⑦ WHT
3 ORN/BLU	⑧ GRN/YEL
4 WHT/BLU	⑨ ORN/WHT
5 BLU/YEL	⑩ RED/BLU

C433

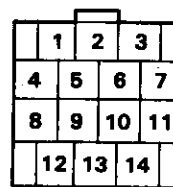

① YEL/GRN ¹	⑧ ORN ²
2 YEL/RED	⑨ WHT/BLU
3 BLU/RED	⑩ WHT/RED
④ BLK ²	11 RED
⑤ BLK ¹	⑫ BLK/YEL
⑥ WHT/GRN	⑬ YEL/BLK
7 BLU	⑭ YEL/WHT

C484 (H22A1 engine)



① GRN/YEL

NOTE: Different wires with the same color have been given a number suffix to distinguish them (for example YEL/BLK₁ and YEL/BLK₂ are not the same).

○: Related to Fuel and Emissions System.

(cont'd)

System Description

System Connectors [Engine Compartment] (cont'd)

H22A1 engine (USA: Si VTEC/Canada: SR-V)
H23A1 engine (USA: Si/Canada: SR)

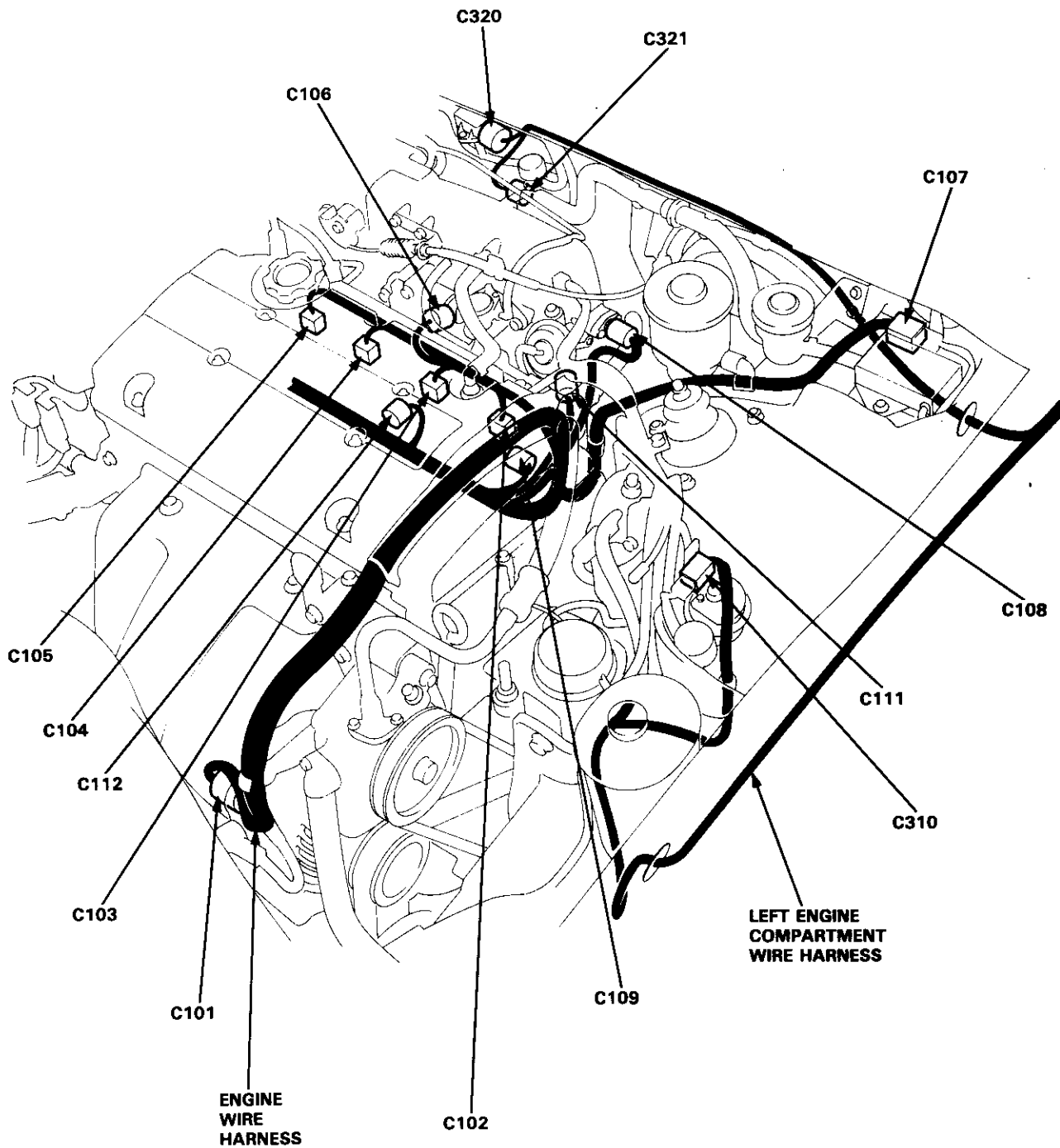

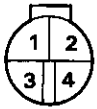
**C101**

①	WHT/RED
②	WHT/GRN
③	WHT/BLU
④	BLK/YEL

C102

①	RED/BLK
②	BRN

C103

①	RED/BLK
②	RED ¹

C104

①	RED/BLK
②	BLU

C105

①	RED/BLK
②	YEL

C106

①	BLK/BLU
②	YEL/BLK

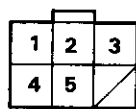
C107

①	RED/BLK
②	RED/BLK
③	YEL/BLK
④	RED/BLK
⑤	RED/BLK
⑥	—

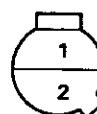
C108

①	GRN/WHT ²
②	RED/YEL

C109

①	BLK/YEL
②	PNK

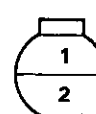
C111

①	RED/GRN
②	BLK ¹

C112

①	RED/BLU
2	—

C310

①	RED ₂
②	BLK/YEL

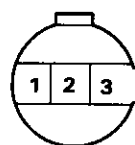
C320

①	WHT/BLU
②	BLU/WHT
③	RED/WHT

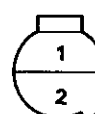
C321

①	RED/GRN
②	BLK/YEL

NOTE: Different wires with the same color have been given a number suffix to distinguish them (for example YEL/BLK₁ and YEL/BLK₂ are not the same).

○: Related to Fuel and Emissions System.

(cont'd)

System Description

System Connectors [Engine Compartment] (cont'd)

F22A1 engine (S):

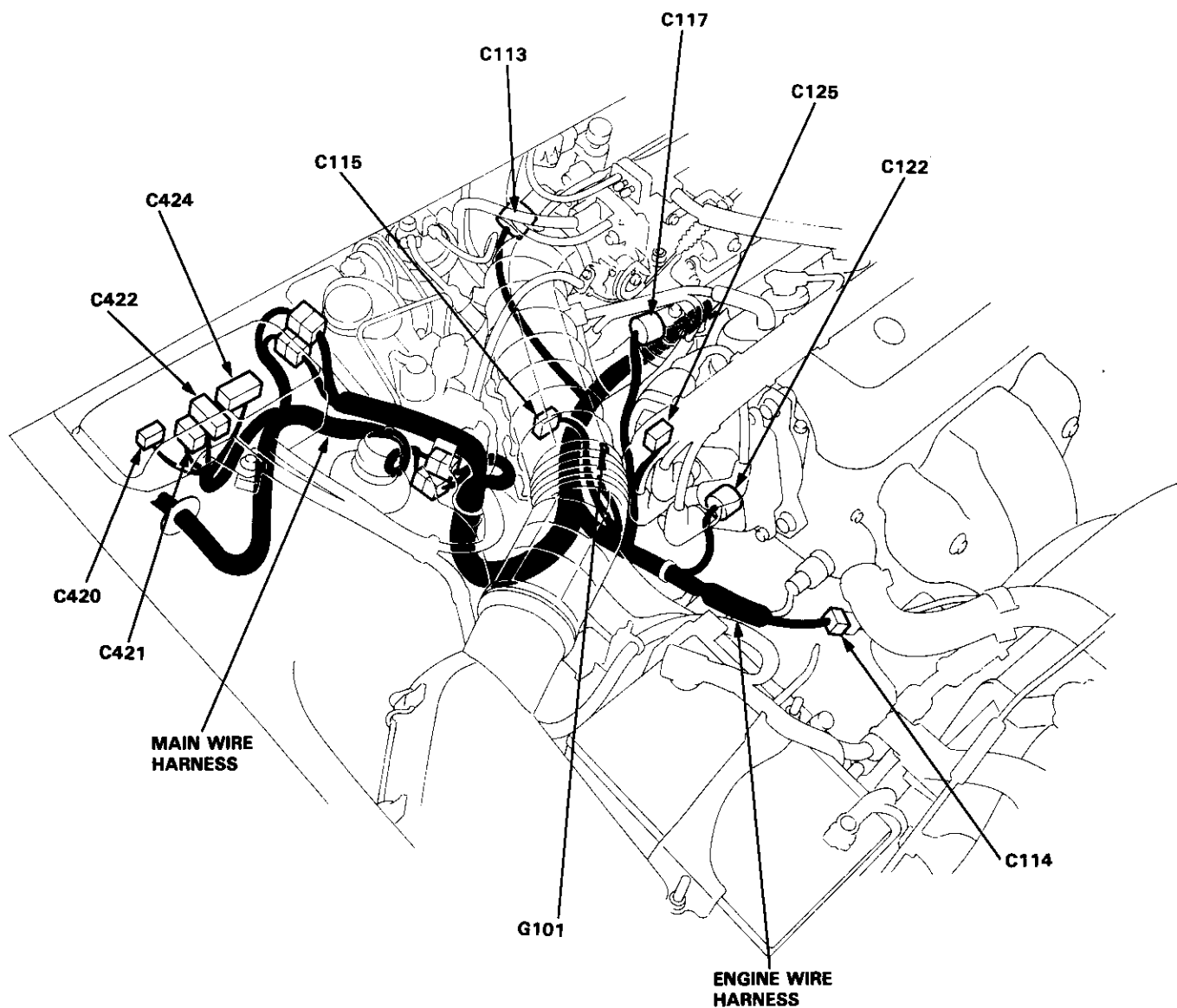



C113

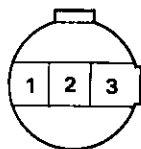

①	YEL/WHT
②	RED/BLK
③	GRN/WHT ²

C114

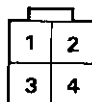

①	GRN/WHT ²
②	WHT
③	ORN/WHT
④	YEL/BLK

C115

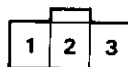

①	ORN ²
②	BLK/YEL
③	BLK ²

C117

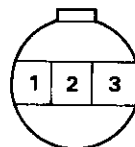

①	RED/WHT
②	GRN/WHT ²
③	WHT/BLK

C122



①	GRN/WHT ²
②	YEL/BLU

C125

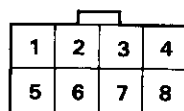

①	ORN ³
②	ORN/BLU
③	BLU/GRN
④	YEL/GRN ¹
⑤	WHT
⑥	WHT/BLU
⑦	BLU/YEL
⑧	BLU

C420

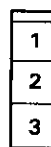

①	BLK
②	GRN/BLK
③	BLK/YEL

C421

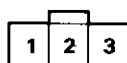

1	WHT
2	BLK/GRN
③	WHT

C422

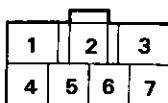

1	WHT/BLU (ABS)
2	WHT/BLU
③	WHT/RED
4	BLK
5	BLU/RED
6	WHT (ABS)
⑦	WHT/YEL

C424

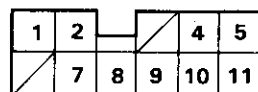

1	RED/BLU	6	—
2	WHT/GRN (ABS)	⑦	WHT/YEL
3	—	8	WHT/BLK (ABS)
4	RED/GRN	9	BLK/YEL (ABS)
5	WHT/GRN	10	WHT (ABS)
		11	WHT/BLU

NOTE: Different wires with the same color have been given a number suffix to distinguish them (for example YEL/BLK₁ and YEL/BLK₂ are not the same).

○: Related to Fuel and Emissions System.

(cont'd)

System Description

System Connectors [Engine Compartment] (cont'd)

F22A1 engine (S):

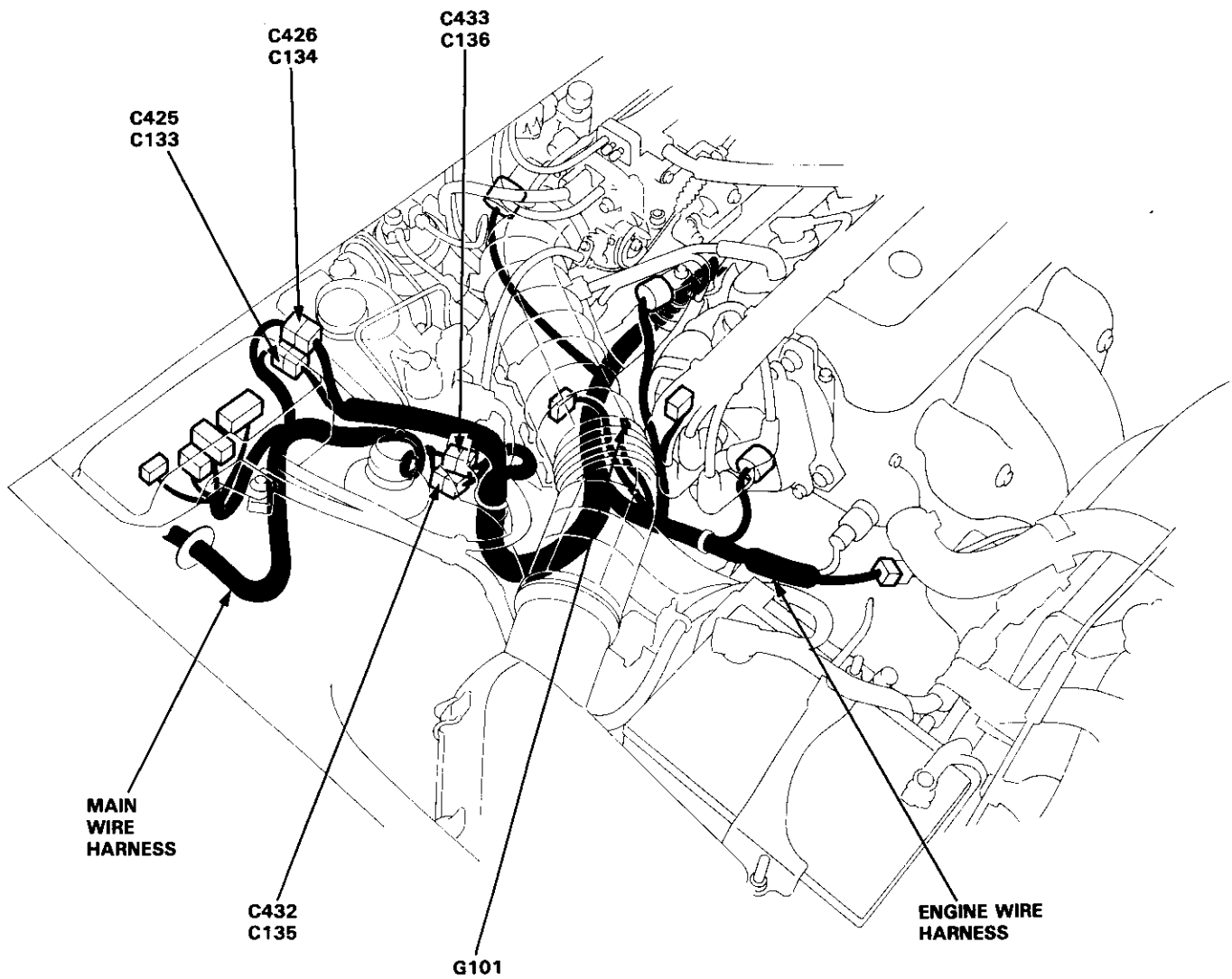



C425

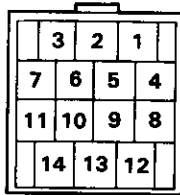

① WHT	⑧ BLK/BLU
② WHT/BLU	⑨ RED/BLK
③ BLU/YEL	⑩ GRN/WHT ²
④ BRN	⑪ BLK/RED
⑤ RED ¹	⑫ ORN ³
⑥ BLU	⑬ ORN/BLU
⑦ YEL	⑭ BLU/GRN

C426

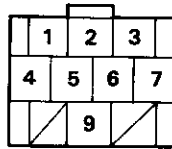

① RED/YEL	⑤ WHT/BLK
2 GRN/BLK	8 WHT/YEL
3 WHT/BLK (A/T)	⑦ YEL/BLU
3 YEL	8 —
4 RED/WHT (A/T)	⑨ RED/GRN
4 RED/WHT	10 —

C432 (M/T)

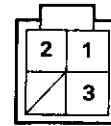

① BRN/BLK
② WHT
③ ORN/WHT
4 —

C432 (A/T)

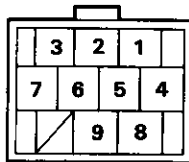

1 BLU/GRN	⑥ BRN/BLK
2 BLU/YEL	⑦ WHT
3 ORN/BLU	8 GRN/YEL
4 WHT/BLU	⑨ ORN/WHT
5 BLU/YEL	10 —

C433

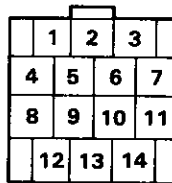

① YEL/GRN ¹	⑥ ORN ²
2 YEL/RED	9 WHT/BLU
3 BLU/RED	⑩ WHT/RED
④ BLK ²	11 RED
⑤ BLK ¹	⑫ BLK/YEL
⑥ WHT/GRN	⑬ YEL/BLK
7 BLU	⑭ YEL/WHT

NOTE: Different wires with the same color have been given a number suffix to distinguish them (for example YEL/BLK₁ and YEL/BLK₂ are not the same).

○: Related to Fuel and Emissions System.

(cont'd)

System Description

System Connectors [Engine Compartment] (cont'd)

F22A1 engine (S):

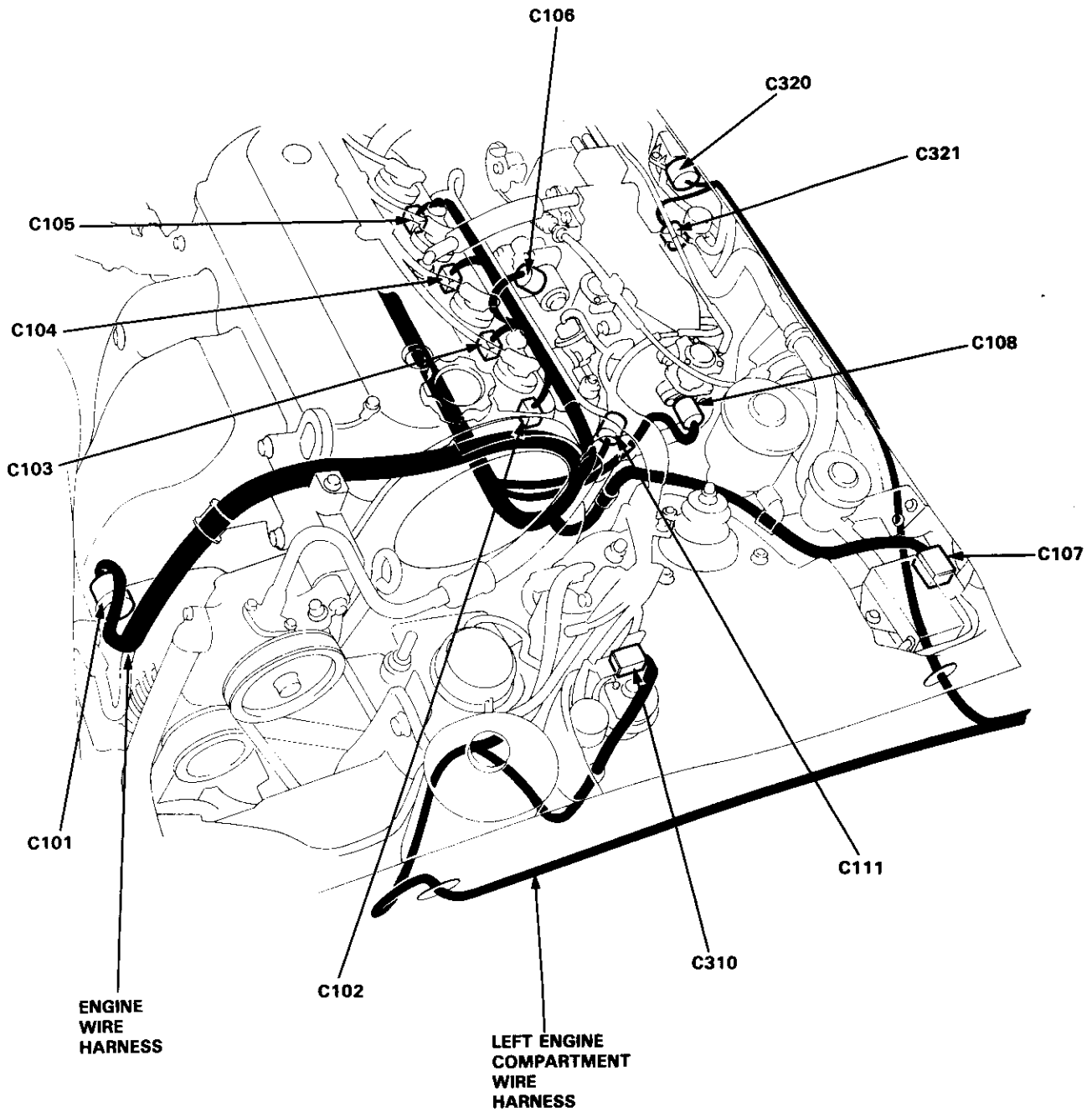



C101



①	WHT/RED
②	WHT/GRN
③	WHT/BLU
④	BLK/YEL

C102

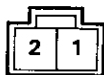

①	RED/BLK
②	BRN

C103

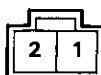

①	RED/BLK
②	RED ¹

C104

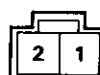

①	RED/BLK
②	BLU

C105

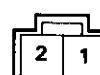

①	RED/BLK
②	YEL

C106



①	BLK/BLU
②	YEL/BLK

C107

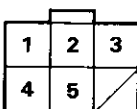

①	RED/BLK
②	RED/BLK
③	YEL/BLK
④	RED/BLK
⑤	RED/BLK
⑥	—

C108



①	GRN/WHT ²
②	RED/YEL

C111



①	RED/GRN
②	BLK ¹

C310



①	RED ₂
②	BLK/YEL

C320



①	WHT/BLU
②	BLU/WHT
③	RED/WHT

C321



①	RED/GRN
②	BLK/YEL

NOTE: Different wires with the same color have been given a number suffix to distinguish them (for example YEL/BLK₁ and YEL/BLK₂ are not the same).

○: Related to Fuel and Emissions System.

(cont'd)

System Description

System Connectors [Dash and Floor] (cont'd)

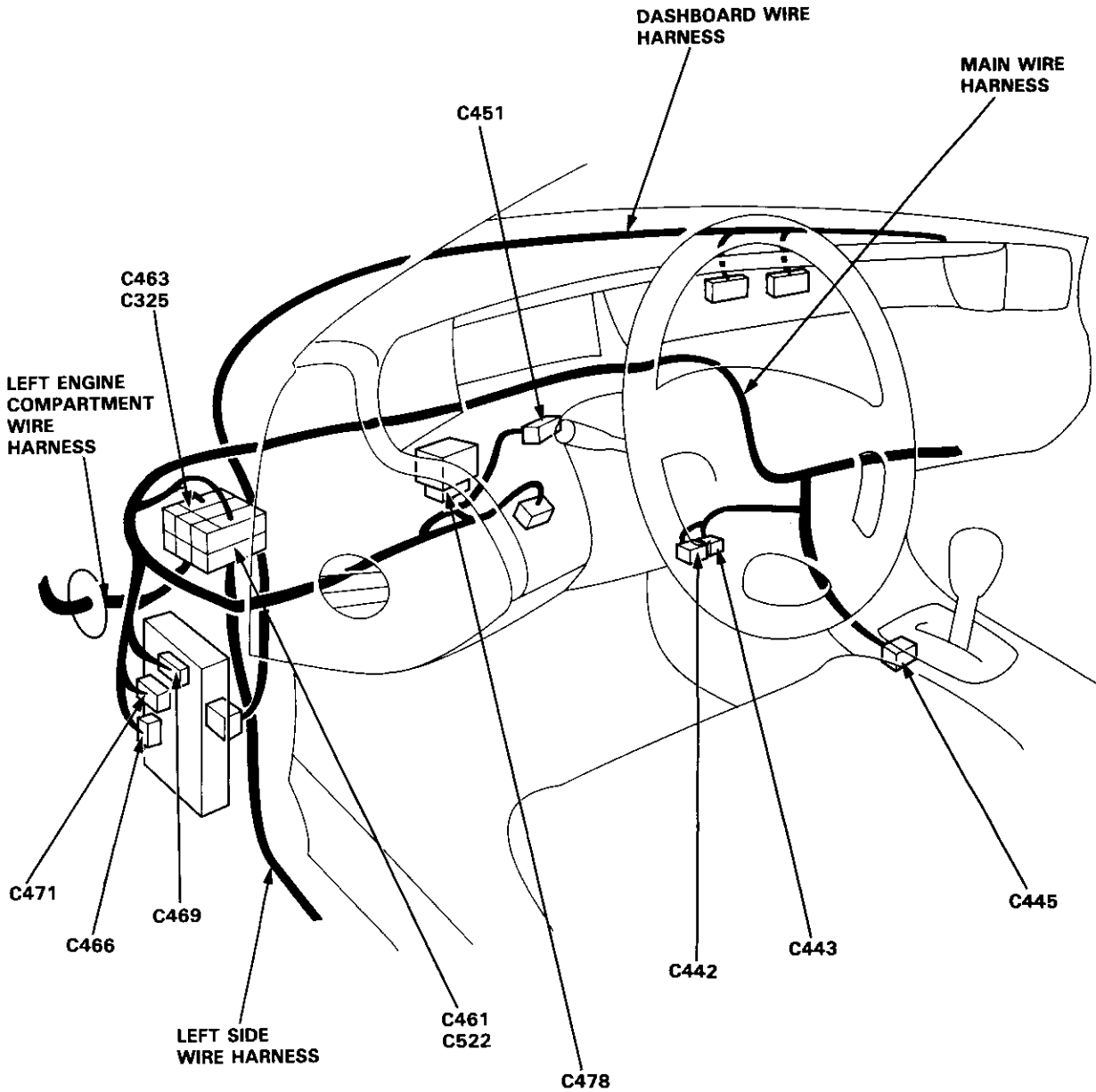



C442



①	BLU/WHT
②	BRN/WHT

C443

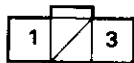

①	LT GRN/RED
2	---
③	BLK/RED

C445 (A/T)

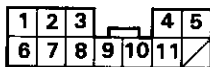

1	GRN/BLK	7	GRN/RED
2	GRN/BLU	8	BLK
3	GRN/YEL	9	GRN/BLK
4	LT GRN/WHT	10	YEL
5	PNK	⑩	GRN/WHT
⑥	GRN	12	---

C451

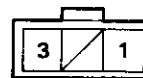

②	WHT
2	---
3	BLK/WHT

C461

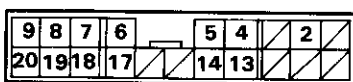

1	---	11	---
2	BLK/GRN**	12	---
3	---	13	RED/BLK
4	GRN/BLK	14	RED/BLU
⑤	YEL	15	---
6	WHT/YEL	16	---
7	GRN/RED	17	YEL/WHT
8	BLU/YEL	18	GRN/RED
9	GRY/WHT	19	RED/YEL
10	---	20	BRN/WHT

C463

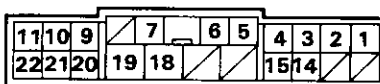

①	BLU/RED	12	---
②	RED/BLU	13	---
3	YEL/BLK	⑭	BLU/BLK
4	WHT/GRN	15	YEL/WHT
5	BRN (ABS)	16	---
6	GRN/BLU (ABS)	17	---
7	GRN/RED	18	BLU
8	---	19	BLU/WHT
⑨	RED/WHT	⑳	BLK/YEL
⑩	WHT/BLU	㉑	RED*
⑪	BLU/WHT	㉒	RED/GRN

C466



1	WHT/BLU
2	BLK/YEL
③	WHT/RED

C469

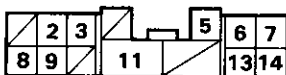

1	---	⑥	GRN/WHT ¹
2	BLU/RED	⑦	GRN/WHT ¹
③	YEL/BLU	10	---
4	---	11	BLU/WHT
5	BLU	12	---
6	BLK	13	BLU
7	YEL	14	BLK/YEL

C471

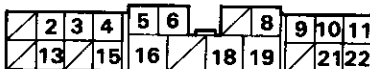

1	---	12	---
2	BLK	13	BLK
③	BLK/YEL	14	---
④	BLK/YEL	⑮	BLU/RED
⑤	BLK/YEL	⑯	BLK/RED
6	GRN/YEL	17	---
7	---	18	BLK
8	YEL/WHT	19	BLK/YEL
9	YEL/RED	20	---
10	GRN/BLU	21	WHT/BLK
11	YEL/BLK	22	YEL/RED*

C478

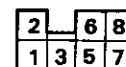

①	YEL/BLU	⑤	BLK/YEL
②	BLK ¹	⑥	BLU/RED
③	YEL/BLK	⑦	YEL
4	---	⑧	GRN/BLK ¹

NOTE: Different wires with the same color have been given a number suffix to distinguish them (for example YEL/BLK₁ and YEL/BLK₂ are not the same).

○: Related to Fuel and Emissions System.

* : Canada

** : Canada (with heated seats)

System Description

System Connectors [Dash and Floor] (cont'd)

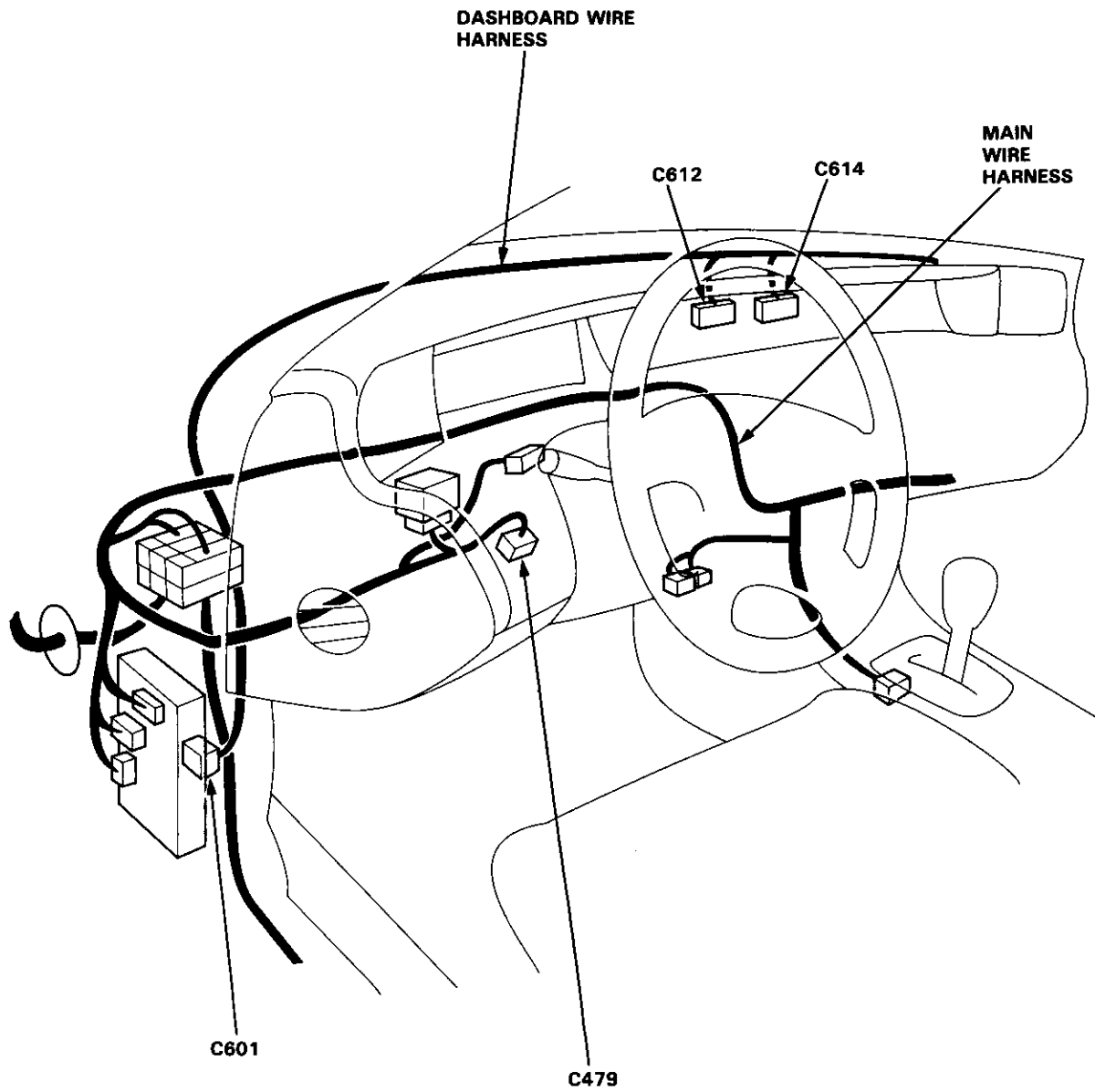



C479

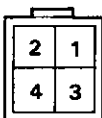

1	GRY
②	WHT/YEL
③	GRN/WHT ¹
4	LT GRN

C601

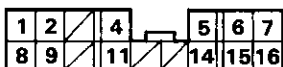

1	RED/BLK	9	GRN/YEL
2	GRN/BLU	10	---
3	---	11	BLK/YEL
④	YEL	12	---
5	BLU/RED	13	---
6	GRN/RED	14	BLK
7	GRN/YEL	15	BLU
8	GRN/BLU	16	BLK/RED

C612



1	PNK	9	LT GRN/WHT
2	---	10	GRN/YEL
3	---	11	GRN/BLU
4	ORN	12	GRN/ORN
5	YEL	⑩	GRN
6	---	14	GRN/RED
7	YEL	⑪	GRN/WHT
⑫	LT GRN	16	BLK

C614



1	---	16	WHT/GRN
2	BLK/YEL	17	BLK
3	---	18	YEL*
4	BLU*	19	GRN/BLU
5	WHT/BLU	20	GRN/BLK
6	GRN/RED	21	GRN/RED
7	---	22	BLU/RED
8	---	⑬	YEL
9	RED	24	BLK/WHT
⑭	BLU/WHT	25	BLU/RED
11	GRN/WHT	26	RED/BLU
12	YEL/RED	27	RED/BLK
13	---	28	---
14	---	29	---
15	---	30	---

NOTE: Different wires with the same color have been given a number suffix to distinguish them (for example YEL/BLK₁ and YEL/BLK₂ are not the same).

○: Related to Fuel and Emissions System.

*: Canada

(cont'd)

System Description

System Connectors [Dash and Floor] (cont'd)

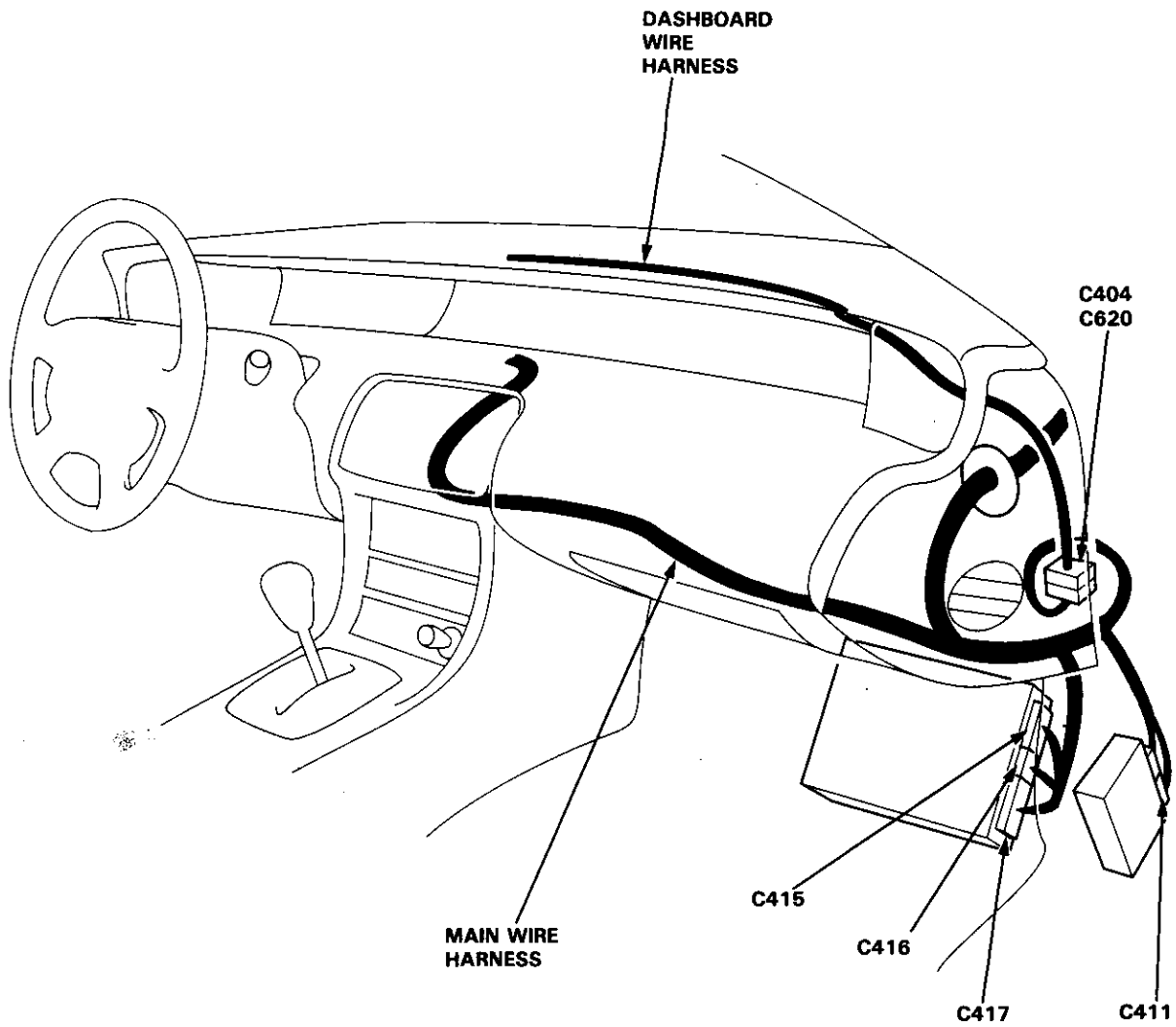



C404

9	8	7	6		5	4	3	2	1	
20	19	18	17	16	15	14	13	12	11	10

① GRN/WHT (A/T)	11 GRN/YEL (A/T)
2 GRN/RED (A/T)	12 BRN/BLK
③ BLU/WHT	13 RED/GRN
4 YEL/RED	14 BRN/BLK
⑤ GRN (A/T)	15 RED/GRN
6 WHT/BLU	16 LT GRN/WHT (A/T)
7 GRN/BLU (A/T)	⑩ LT GRN (A/T)
8 RED	18 WHT/YEL
9 GRN/RED	9 ORN
10 RED/BLU	20 RED/WHT

C411 (A/T)

19	17	15	13	11	9	7	5		
18	16		12	10		6			2

1	---	12	WHT/BLU
2	GRN/WHT	③	ORN ¹
3	---	14	---
4	---	15	BLU/YEL
⑤	YEL/BLU	⑥	ORN/RED
6	BRN/WHT	17	BLU/GRN
⑦	RED/BLK	⑧	LT GRN/BLK
8	---	19	ORN/BLU
9	ORN	20	---
10	---	21	---
⑩	PNK	22	---

C415 (ECM-A)

25	23	21	19	17	15	13	11	9	7	5	3	1
26	24	22	20	18	16		12		8	6	4	2

①	BRN	14	---
②	YEL	⑬	RED/BLU
③	RED ¹	⑭	WHT/GRN
④	GRN/YEL (H22A1 engine)	⑰	PNK***
⑤	BLU	⑯	ORN/RED (A/T)
⑥	ORN/WHT	⑱	WHT***
⑦	GRN/BLK ¹	⑳	RED/GRN
⑧	GRN/BLK ²	㉑	YEL/GRN ¹
⑨	BLK/BLU	㉒	YEL/GRN ²
10	---	㉓	BLK ¹
⑩	RED ²	㉔	BLK ²
⑪	BLU/RED	㉕	YEL/BLK
⑫	BLU/WHT	㉖	BLK/RED

C416 (ECM-B)

15	13	11	9	7	5	3	1
16	14	12	10	8		4	2

①	YEL/BLK	⑥	BLU/RED
②	BRN/BLK	⑩	ORN ²
③	ORN ¹ (A/T)	⑪	ORN ³
④	PNK (A/T)	⑫	WHT
⑤	BLU/BLK	⑬	ORN/BLU
6	---	⑭	WHT/BLU
⑦	LT GRN (A/T)	⑮	BLU/GRN
⑧	RED/GRN	⑯	BLU/YEL

C417 (ECM-D)

21	19	17	15	13	11	9	7		3	1
22	20	18		14	12	10		6	4	2

①	WHT/YEL	⑩	WHT/BLK
②	GRN/WHT ¹	⑪	YEL/BLU
③	RED/BLU***	⑫	WHT
④	BRN/WHT	⑬	RED/YEL
5	---	16	---
⑥	LT BLU (H22A1 engine)	⑰	WHT/BLU
⑦	LT GRN/RED	⑱	LT GRN/BLK (A/T)
8	---	⑲	RED/WHT
⑨	WHT/RED	㉒	YEL/WHT
⑩	GRN/BLK	㉓	BLU/WHT
⑪	RED/BLK	㉔	GRN/WHT ²

NOTE: Different wires with the same color have been given a number suffix to distinguish them (for example YEL/BLK₁ and YEL/BLK₂ are not the same).

○: Related to Fuel and Emissions System.

***: Except F22A1 engine

(cont'd)

System Description

System Connectors [Fuel Pump] (cont'd)

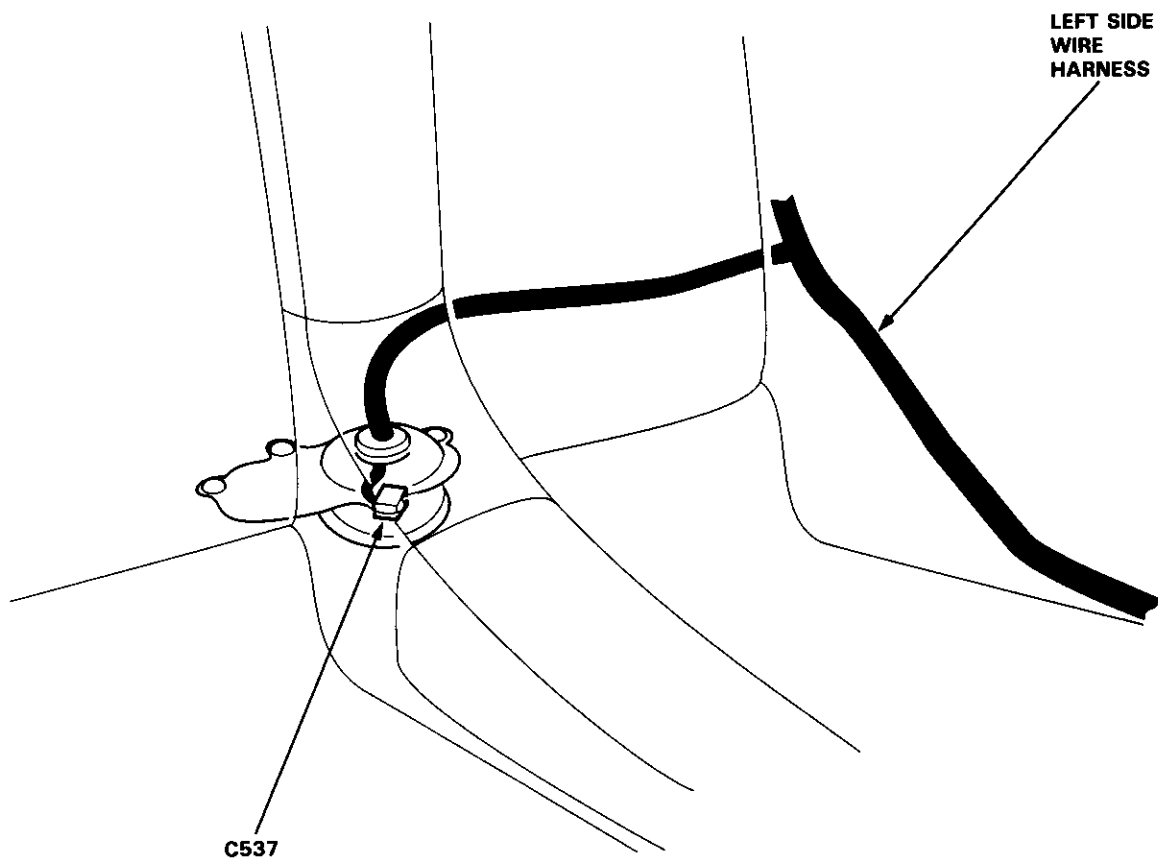



C537

1
2

①	BLK
②	YEL

NOTE: Different wires with the same color have been given a number suffix to distinguish them (for example YEL/BLK₁ and YEL/BLK₂ are not the same).

○: Related to Fuel and Emissions System.

Troubleshooting

Troubleshooting Guide

NOTE: Across each row in the chart, the systems that could be sources of a symptom are ranked in the order they should be inspected starting with ①. Find the symptom in the left column, read across to the most likely source, then refer to the page listed at the top of that column. If inspection shows the system is OK, try the next most likely system ②, etc.

PAGE	SYSTEM	PGM-FI									
		ENGINE CONTROL MODULE	HEATED OXYGEN SENSOR	MANIFOLD ABSOLUTE PRESSURE SENSOR	TOP DEAD CENTER/ CRANKSHAFT POSITION/CYLINDER POSITION SENSOR	ENGINE COOLANT TEMPERATURE SENSOR	THROTTLE POSITION SENSOR	INTAKE AIR TEMPERATURE SENSOR	BAROMETRIC PRESSURE SENSOR	IGNITION OUTPUT SIGNAL	VEHICLE SPEED SENSOR
	SYMPTOM	50	56, 58, 62	64, 68	70	72	74	76	78	80	82
	MALFUNCTION INDICATOR LAMP (MIL)** TURNS ON										
	MALFUNCTION INDICATOR LAMP (MIL)** BLINKS	4 or 5	1 or 41 or 42	3 or 31	4 or 11 or 31	6	7	10	13	15	17
	ENGINE WON'T START	③			③					③	
	DIFFICULT TO START ENGINE WHEN COLD	BU		③	②	①					
IRREGULAR IDLING	WHEN COLD FAST IDLE OUT OF SPEC.	BU				③					
	ROUGH IDLE	BU		③							
	WHEN WARM RPM TOO HIGH	BU									
	WHEN WARM RPM TOO LOW	BU									
FREQUENT STALLING	WHILE WARMING UP	BU				③					
	AFTER WARMING UP	BU									
POOR PERFORMANCE	MISFIRE OR ROUGH RUNNING	BU		②	③						
	FAILS EMISSION TEST	BU	③	②							
	LOSS OF POWER	BU		③			②				

* If codes other than those listed above are indicated, count the number of blinks again. If the MIL is in fact blinking these codes, replace the ECM.

BU If the MIL is on while the engine is running, jump the service check connector. If no code is displayed (MIL stays on steady), the back-up system is in operation.

Substitute a known-good ECM and recheck. If the indication goes away, replace the original ECM.

** USA:
MALFUNCTION
INDICATOR
LAMP (MIL)



Canada:
CHECK
ENGINE
LIGHT



*** Except F22A1 engine (s)

**** H22A1 engine (USA: Si VTEC/Canada: SR-V)



ELECTRICAL LOAD DETECTOR	PGM-FI					IDLE CONTROL		FUEL SUPPLY		INTAKE AIR	EMISSION CONTROL	
	VARIABLE VALVE TIMING & VALVE LIFT ELECTRONIC CONTROL SOLENOID VALVE ****	VARIABLE VALVE TIMING & VALVE LIFT ELECTRONIC CONTROL PRESSURE SWITCH ****	KNOCK SENSOR ***	A/T FI SIGNAL A	A/T FI SIGNAL B	IDLE AIR CONTROL VALVE	OTHER IDLE CONTROLS	FUEL INJECTOR	OTHER FUEL SUPPLY		EXHAUST GAS RECIRCULATION CONTROL SYSTEM	OTHER EMISSION CONTROLS
84	6-75	6-77	88	90	90	96	92	116	113	131	153	149
20	21	22	23	30	31	14		16			12	
								2	1			
						1	2					
						1		2			3	
						1	2					
3						1		2				
						1	2		3			
						3			1		2	
								1			3	
												1
	3	3						3	1	3		

Troubleshooting

Self-diagnostic Procedures

1. When the Malfunction Indicator Lamp (MIL) has been reported on, do the following:

1. Connect the service check connector terminals with a jumper wire as shown (the service check connector is located behind the center console). Turn the ignition switch on.

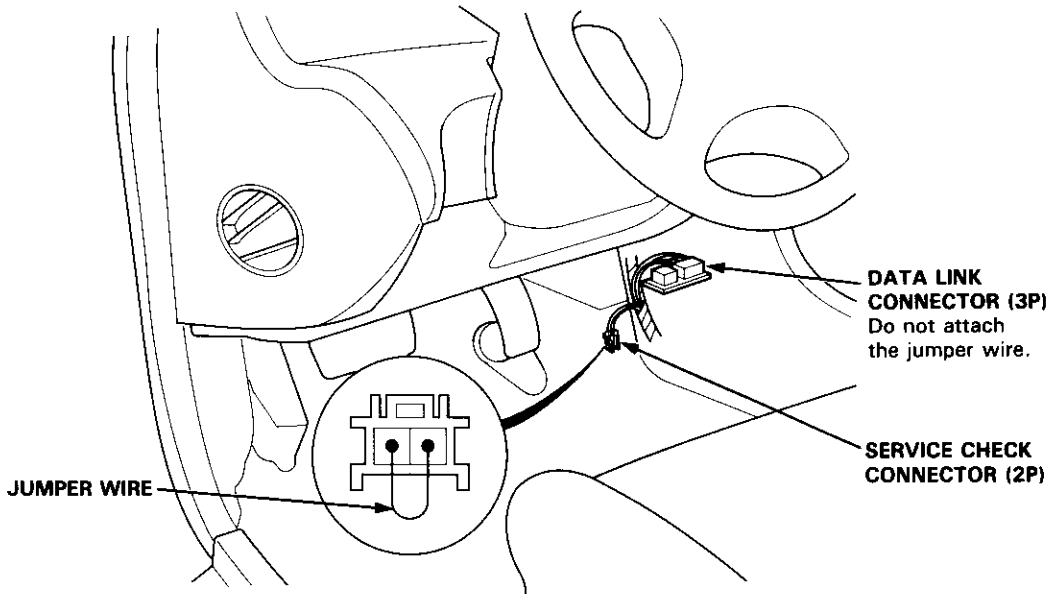

2. Note the Diagnostic Trouble Code (DTC): The MIL indicates a code by the length and number of blinks. The MIL can indicate simultaneous component problems by blinking separate codes, one after another. Codes 1 through 9 are indicated by individual short blinks. Codes 10 through 43 are indicated by a series of long and short blinks. The number of long blinks equals the first digit, the number of short blinks equals the second digit.

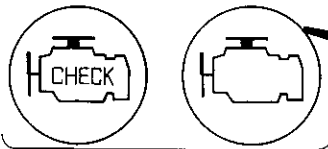

USA:
MALFUNCTION
INDICATOR
LAMP
(MIL)

CANADA:
CHECK
ENGINE
LIGHT



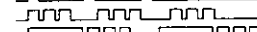

Separate Problems:

Short

 = See DTC 1
 = See DTC 3
 = See DTC 13

Long short

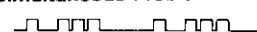
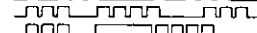
Simultaneous Problems:

 = See DTC 1 and 3
 = See DTC 3 and 4
 = See DTC 3 and 14



II. Engine Control Module (ECM) Reset Procedure

1. Turn the ignition switch off.
2. Remove the the CLOCK RADIO (10 A) fuse from the under-hood fuse/relay box for 10 seconds to reset the ECM.

NOTE:

- Disconnecting the CLOCK RADIO (10 A) fuse also cancels the radio preset stations and the clock setting. Make note of the radio presets before removing the fuse so you can reset them.
- The radio may have a coded theft protection circuit. Be sure you get the customer's code number before removing the CLOCK RADIO (10 A) fuse.

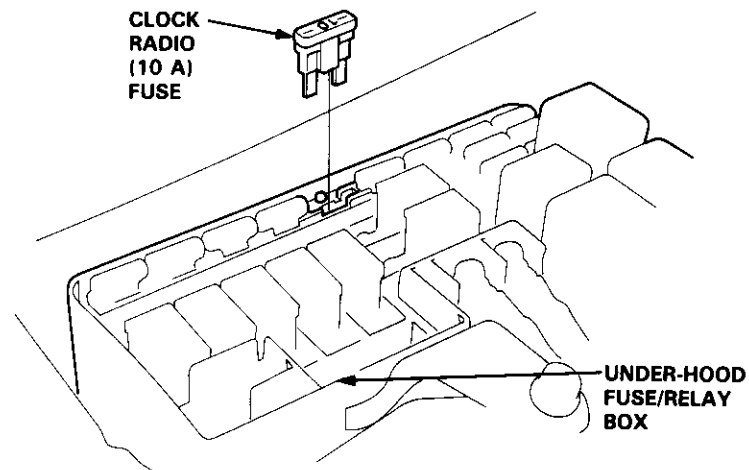

III. Final Procedure (this procedure must be done after any troubleshooting)

1. Remove the jumper wire.

NOTE: If the service check connector is jumped, the MIL will stay on.

2. Do the ECM Reset Procedure.
3. Set the radio preset stations and the clock.

Troubleshooting

Self-diagnostic Procedures (cont'd)

DIAGNOSTIC TROUBLE CODE (DTC)	SYSTEM INDICATED	Page
0	ENGINE CONTROL MODULE (ECM)	11-50
1	HEATED OXYGEN SENSOR (HO2S)	11-56
3	MANIFOLD ABSOLUTE PRESSURE (MAP SENSOR)	11-64, 68
5		
4	CRANKSHAFT POSITION (CKP SENSOR)	11-70
6	ENGINE COOLANT TEMPERATURE (ECT SENSOR)	11-72
7	THROTTLE POSITION (TP SENSOR)	11-74
8	TOP DEAD CENTER POSITION (TDC SENSOR)	11-70
9	No. 1 CYLINDER POSITION (CYP SENSOR)	11-70
10	INTAKE AIR TEMPERATURE (IAT SENSOR)	11-76
12	EXHAUST GAS RECIRCULATION (EGR VALVE LIFT SENSOR)	11-153
13	BAROMETRIC PRESSURE (BARO SENSOR)	11-78
14	IDLE AIR CONTROL (IAC VALVE)	11-96
15	IGNITION OUTPUT SIGNAL	11-80
16	FUEL INJECTOR	11-116
17	VEHICLE SPEED SENSOR (VSS)	11-82
20	ELECTRICAL LOAD DETECTOR (ELD)	11-84
21	VARIABLE VALVE TIMING & VALVE LIFT ELECTRONIC CONTROL (VTEC) SOLENOID VALVE**	6-75
22	VARIABLE VALVE TIMING & VALVE LIFT ELECTRONIC CONTROL (VTEC) PRESSURE SWITCH**	6-77
23	KNOCK SENSOR (KS)*	11-88
41	HEATED OXYGEN SENSOR (HO2S) HEATER	11-58
43	FUEL SUPPLY SYSTEM	11-62

*: Except F22A1 engine(S)

** : H22A1 engine (USA: Si VTEC/Canada: SR-V)

- If codes other than those listed above are indicated, verify the code. If the code indicated is not listed above, replace the ECM.
- The Malfunction Indicator Lamp (MIL) may come on, indicating a system problem when, in fact, there is a poor or intermittent electrical connection. First, check the electrical connections, clean or repair connections if necessary.
- The MIL and D4 indicator light may light simultaneously when the code blinks 6, 7 and 17. Check the PGM-FI system according to the PGM-FI system troubleshooting, then recheck the D4 indicator light. If it lights, see page 14-36.
- The MIL does not come on when there is a malfunction in the A/T FI signal or electrical load detector circuits. However, it will indicate the codes when the service check connector is jumped.



If the inspection for a particular failure code requires the test harness, remove the right door sill molding and the small cover on the right kick panel and pull the carpet back to expose the ECM. Unbolt the ECM cover. With the ignition switch off, connect the test harness. Check the system according to the procedure described for the appropriate code(s) listed on the following pages.

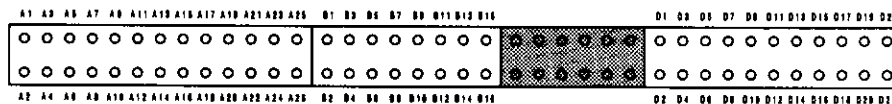
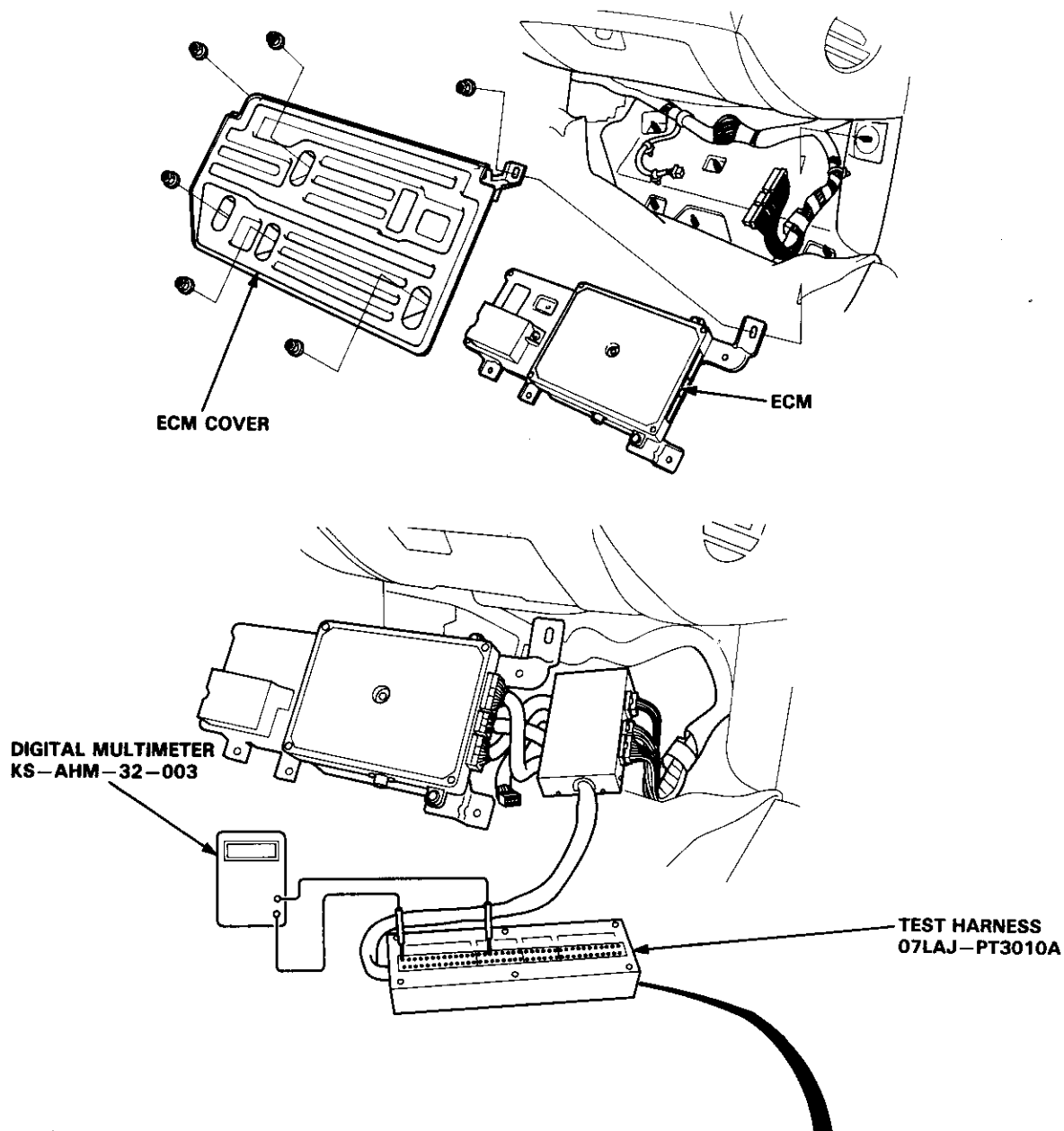

TERMINAL LOCATIONS

(cont'd)

Troubleshooting

Self-diagnostic Procedures (cont'd)

CAUTION:

- Puncturing the insulation on a wire can cause poor or intermittent electrical connections.
- For testing at connectors other than the test harness, bring the tester probe into contact with the terminal from the connector side of wire harness connectors in the engine compartment. For female connectors, just touch lightly with the tester probe and do not insert the probe.

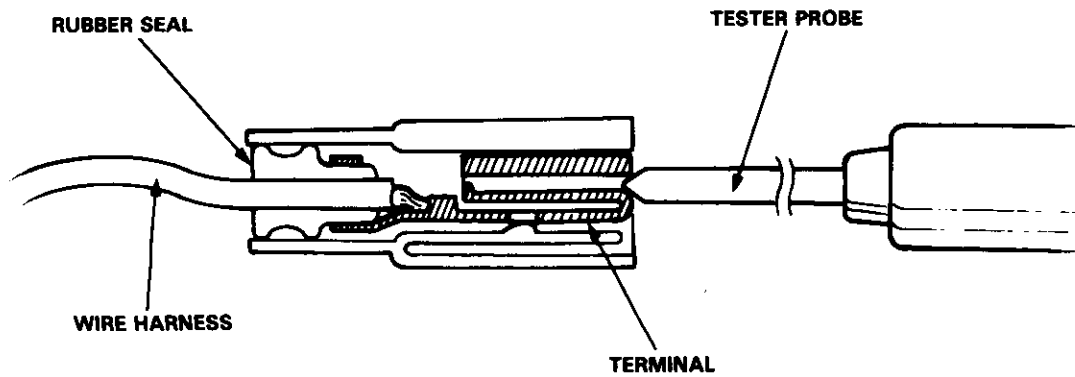



How to Read Flowcharts

A flowchart is designed to be used from start to final repair. It's like a map showing you the shortest distance. But beware: if you go off the "map" anywhere but a "stop" symbol, you can easily get lost.

- START**
(bold type) Describes the conditions or situation to start a troubleshooting flowchart.
- ACTION** Asks you to do something; perform a test, set up a condition etc.
- DECISION** Asks you about the result of an action, then sends you in the appropriate troubleshooting direction.
- STOP**
(bold type) The end of a series of actions and decisions, describes a final repair action and sometimes directs you to an earlier part of the flowchart to confirm your repair.

NOTE:

- The term "Intermittent Failure" is used in these charts. It simply means a system may have had a failure, but it checks out OK at this time. If the Malfunction Indicator Lamp (MIL) on the dash does not come on, check for poor connections or loose wires at all connectors related to the circuit that you are troubleshooting (see illustration below).
- Most of the troubleshooting flowcharts have you reset the Engine Control Module (ECM) and try to duplicate the diagnostic trouble code (DTC). If the problem is intermittent and you can't duplicate the code, do not continue through the flowchart. To do so will only result in confusion and, possibly, a needlessly replaced ECM.
- "Open" and "Short" are common electrical terms. An open is a break in a wire or at a connection. A short is an accidental connection of a wire to ground or to another wire. In simple electronics, this usually means something won't work at all. In complex electronics (like ECM's), this can sometimes mean something works, but not the way it's supposed to.
- If the electrical readings are not as specified when using the test harness, check the test harness connections before proceeding.

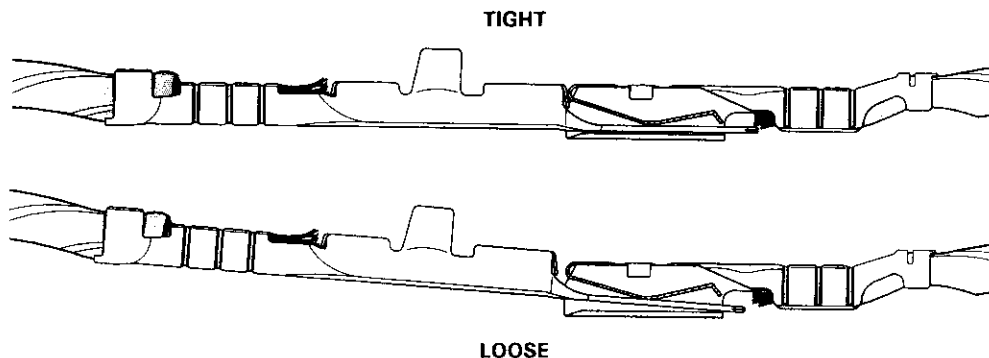

PGM-FI System

System Description

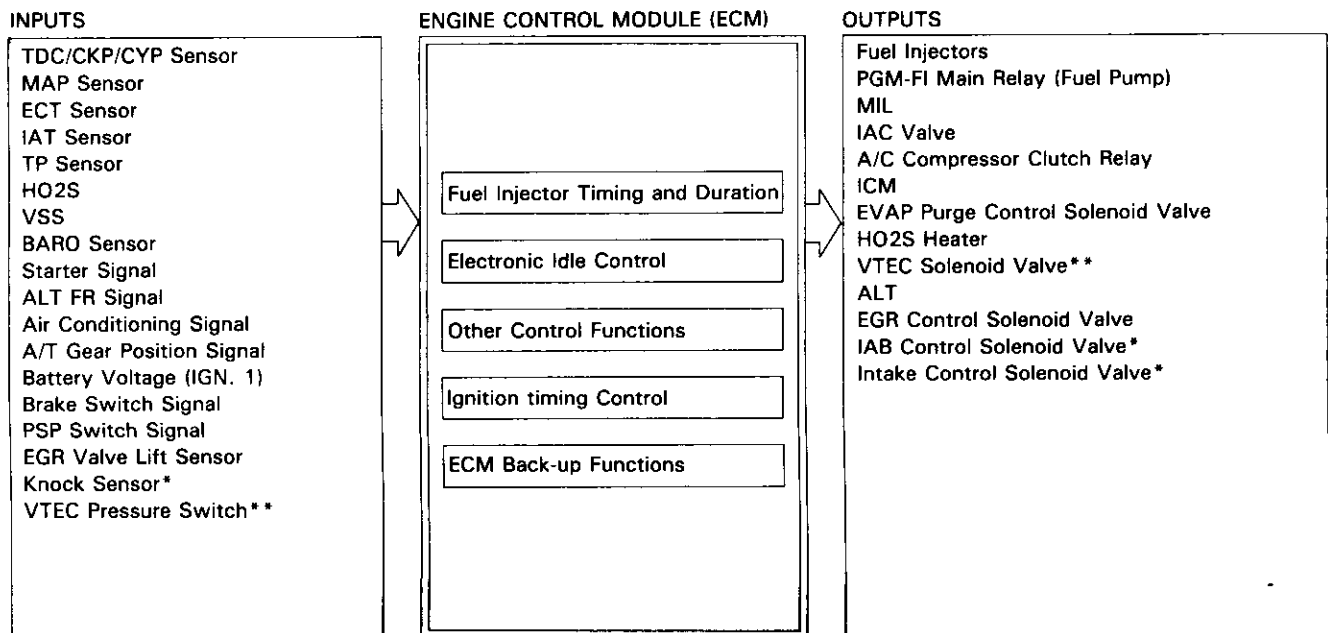

*: Except F22A1 engine
**: H22A1 engine

PGM-FI System

The PGM-FI system on this model is a sequential multiport fuel injection system.

Fuel Injector Timing and Duration

The ECM contains memories for the basic discharge durations at various engine speeds and manifold pressures. The basic discharge duration, after being read out from the memory, is further modified by signals sent from various sensors to obtain the final discharge duration.

Idle Air Control

Idle Air Control Valve (IAC Valve)

When the engine is cold, the A/C compressor is on, the transmission is in gear (A/T only) or the alternator is charging, the ECM controls current to the IAC Valve to maintain correct idle speed.

Ignition Timing Control

- The ECM contains memories for basic ignition timing at various engine speeds and manifold pressures. Ignition timing is also adjusted for engine coolant temperature.
- A Knock Control System is also used. When detonation is detected by the knock sensor, the ignition timing is retarded (Except F22A1 engine).

Other Control Functions

1. Starting Control
When the engine is started, the ECM provides a rich mixture by increasing fuel injector duration.
2. Fuel Pump Control
 - When the ignition switch is initially turned on, the ECM supplies ground to the PGM-FI main relay that supplies current to the fuel pump for two seconds to pressurize the fuel system.
 - When the engine is running, the ECM supplies ground to the PGM-FI main relay that supplies current to the fuel pump.
 - When the engine is not running and the ignition is on, the ECM cuts ground to the PGM-FI main relay which cuts current to the fuel pump.
3. Fuel Cut-off Control
 - During deceleration with the throttle valve closed, current to the fuel injectors is cut off to improve fuel economy at speeds over 1,100 rpm.
 - Fuel cut-off action also takes place when engine speed exceeds, F22A1 (S): 6,600 rpm, H23A1 (USA: Si/Canada: SR): 6,800 rpm, H22A1 (USA: Si VTEC/Canada: SR-V): 7,700 rpm, regardless of the position of the throttle valve, to protect the engine from over-revving.



4. **A/C Compressor Clutch Relay**
When the ECM receives a demand for cooling from the air conditioning system, it delays the compressor from being energized, and enriches the mixture to assure smooth transition to the A/C mode.
5. **Evaporative Emission (EVAP) Purge Control Solenoid Valve**
When the engine coolant temperature is below 167°F (75°C) [H22A1 engine (USA: Si VTEC/Canada: SR-V): 158°F (70°C)], the ECM supplies a ground to the EVAP purge control solenoid valve which cuts vacuum to the EVAP purge control diaphragm valve.
6. **Intake Air Bypass (IAB) Control Solenoid Valve**
When the engine speed is below 4,800 rpm [H22A1 engine (USA: Si VTEC/Canada: SR-V): 4,600 rpm], the IAB control solenoid valve is activated by a signal from the ECM, intake air flows through the long intake path, then high torque is delivered. At speeds higher than 4,800 (or 4,600) rpm, the solenoid valve is deactivated by the ECM, and intake air flows through the short intake path in order to reduce the resistance in airflow.
7. **Intake Control Solenoid Valve**
When the engine speed is below 4,000 rpm, the ECM supplies a ground to the intake control solenoid valve. This opens the solenoid valve sending intake manifold vacuum to the intake control diaphragm.
8. **Exhaust Gas Recirculation (EGR) Control Solenoid Valve**
When the EGR is required for control of oxides of nitrogen (NOx) emission, the ECM supplies ground to the EGR control solenoid valve which supplies regulated vacuum to the EGR valve.
9. **Alternator (ALT) Control**
The system controls the voltage generated at the alternator in accordance with the electrical load and drive mode, and reduces the engine load to improve the fuel economy.

ECM fail-safe/back-up Functions

1. **Fail-safe Function**
When an abnormality occurs in a signal from a sensor, the ECM ignores that signal and assumes a pre-programmed value for that sensor that allows the engine to continue to run.
2. **Back-up Function**
When an abnormality occurs in the ECM itself, the fuel injectors are controlled by a back-up circuit independent of the system in order to permit minimal driving.
3. **Self-diagnosis Function [Malfunction Indicator Lamp (MIL)]**
When an abnormality occurs in a signal from a sensor, the ECM lights the MIL and stores the code in erasable memory. When the ignition is initially turned on, the ECM supplies ground for the MIL for two seconds to check the MIL bulb condition.

PGM-FI System

Troubleshooting Flowchart — Engine Will Not Start

Engine will not start.

Watch the Malfunction Indicator Lamp (MIL) and turn the ignition switch ON.

Did the MIL come on at all?

NO

Perform troubleshooting on page 11-51.

YES

Did the MIL go off after two seconds?

NO

Perform troubleshooting on page 11-52.

YES

Turn the ignition switch OFF.

Connect the test harness between the ECM and connectors (see page 11-45).

Turn the ignition switch ON.

Measure voltage between body ground and the following terminals individually: A23, A24.

Is there less than 1.0 V?

NO

Repair open in wire(s) between ECM and G101 (located at thermostat housing) that had more than 1.0 V.

YES

Inspect fuel pressure (see page 11-115).

Is fuel pressure OK?

NO

Repair as necessary (see page 11-115).

YES

Perform ignition system check (see section 23).

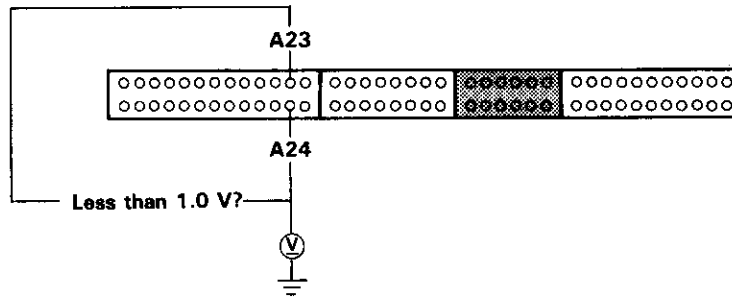



Troubleshooting Flowchart – Engine Control Module (ECM)

The Malfunction Indicator Lamp (MIL) never comes on (even for two seconds) after ignition is turned on.

Is the low oil pressure light on?

NO

Inspect No. 13 METER (10 A) fuse (in the under-dash fuse/relay box).

YES

Turn the ignition switch OFF.

Connect the test harness between the ECM and connectors (see page 11-45).

Connect A13 terminal to body ground.

Turn the ignition switch ON.

Is the MIL on?

NO

– Replace the MIL bulb.
– Repair open in BLU/WHT wire between ECM (A13) and gauge assembly.

YES

Measure voltage between body ground and the following terminals individually: A23, A24.

Is there less than 1.0 V?

NO

Repair open in wire(s) between ECM and G101 (located at thermostat housing) that had more than 1.0 V.

YES

Substitute a known-good ECM and recheck. If symptom/indication goes away, replace the original ECM.

Is the fuse OK?

NO

Replace the fuse.

YES

Repair open in YEL wire between No. 13 METER (10 A) fuse and gauge assembly.

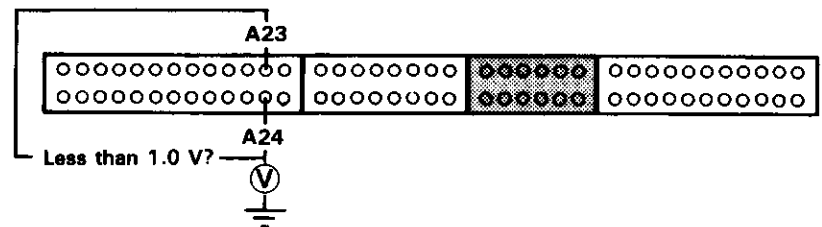
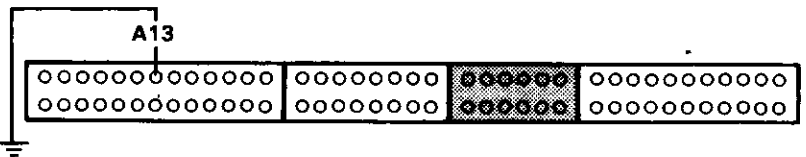

G101

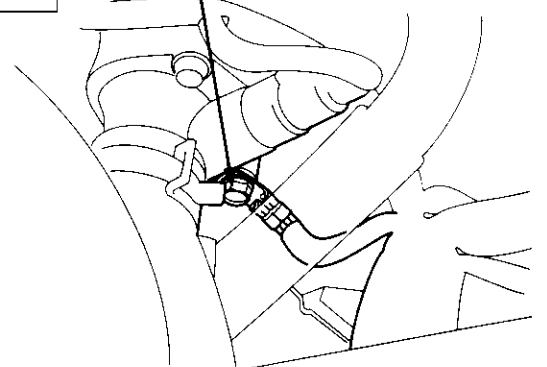

PGM-FI System

Troubleshooting Flowchart — Engine Control Module (ECM)

NOTE: When there is no code stored, the MIL will stay on if the service check connector is jumped.

The Malfunction Indicator Lamp (MIL) stays on or comes on after two seconds.

Connect the service check connector terminals with a jumper wire (see page 11-42).

Turn the ignition switch ON.

Does the MIL indicate any Diagnostic Trouble Code (DTC)?

YES
Go to self-diagnostic procedures (see page 11-40).

NO

Remove the jumper wire from the service check connector.

Try to start the engine.

Did the engine start?

YES

Turn the ignition switch OFF.

Connect the test harness between the ECM and connectors (see page 11-45).

Turn the ignition switch ON.

Measure voltage between D4 (+) terminal and D21 (-) terminal.

Is there approx. 5V (A/T: 11 V)?

YES

Connect the service check connector terminals with a jumper wire.

Measure voltage between D4 (+) terminal and D21 (-) terminal.

Is there approx. 5 V (A/T: 11 V)?

YES

Remove the jumper wire from the service check connector.

(To page 11-53)

NO

Repair short to body ground in BRN/ WHT wire between the ECM (D4), Transmission Control Module (TCM), ABS control unit or 4WS control unit and service check connector.

- * — Repair open in BRN/WHT wire between ECM (D4) and service check connector.
- Repair open in BLU/WHT wire between service check connector and ECM (D21).

NO

Replace the fuse.

Remove and inspect the NO. 4 BACK UP (10 A) fuse in the underdash fuse/relay box.

Is the fuse OK?

YES

(To page 11-53)

*NOTE: After repair, disconnect the service check connector jumper wire, test drive the car, and recheck the MIL for code.

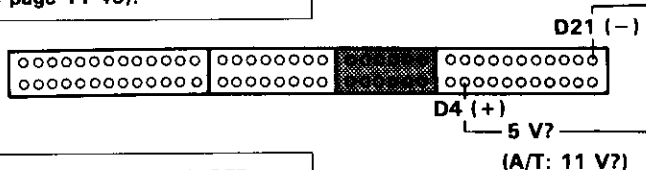

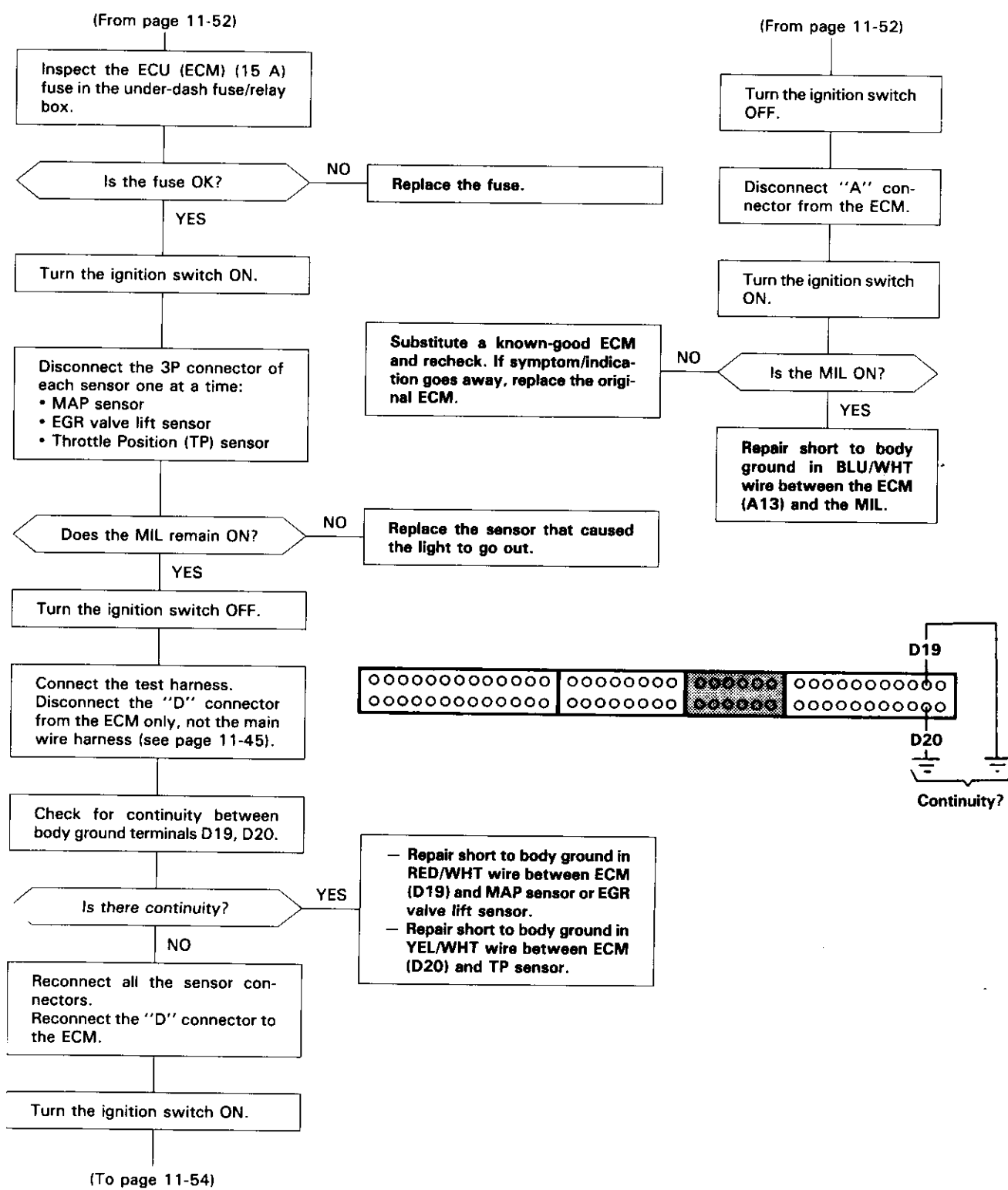

(cont'd)

PGM-FI System

Troubleshooting Flowchart — Engine Control Module (ECM) (cont'd)

(From page 11-53)

Measure voltage between body ground and the following terminal individually: A26, B2.

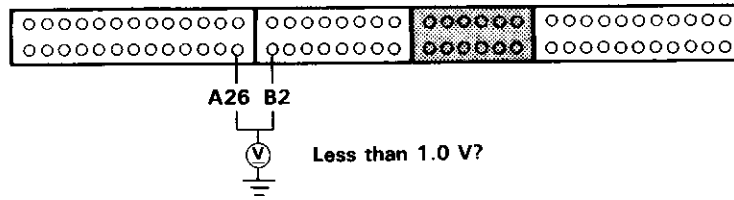

Is there less than 1.0 V?

NO

Repair open in BLK/RED (A26) or BRN/BLK (B2) and G101 (located at thermostat housing).

YES

Measure voltage between A26 (-) and the following: B1 (+) and A25 (+).

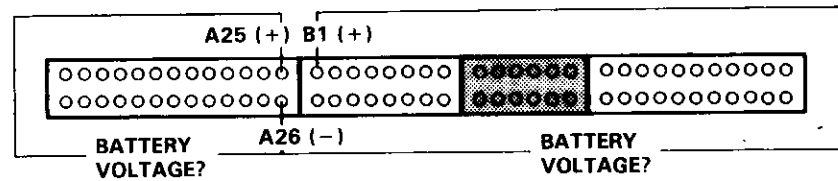

Is there battery voltage?

NO

- Repair open in YEL/BLK wire between ECM (A25, B1) and PGM-FI main relay.
- Check PGM-FI main relay and wiring connectors at PGM-FI main relay.

YES

Substitute a known-good ECM and recheck. If symptom/indication goes away, replace the original ECM.

PGM-FI System

Troubleshooting Flowchart — Heated Oxygen Sensor (HO2S)

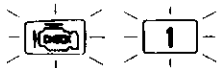

The Malfunction Indicator Lamp (MIL) indicates Diagnostic Trouble Code (DTC) 1: A problem in the Heated Oxygen Sensor (HO2S) circuit.

The Heated Oxygen Sensor (HO2S) detects the oxygen content in the exhaust gas and signals the ECM. In operation, the ECM receives the signals from the sensor and varies the duration during which fuel is injected. The HO2S has an internal heater. The heater stabilizes the sensor's output. The HO2S is installed in the exhaust manifold (H23A1 engine (USA: Si/Canada: SR), H22A1 engine (USA: Si VTEC/Canada: SR-V); in the exhaust pipe A).

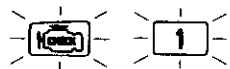
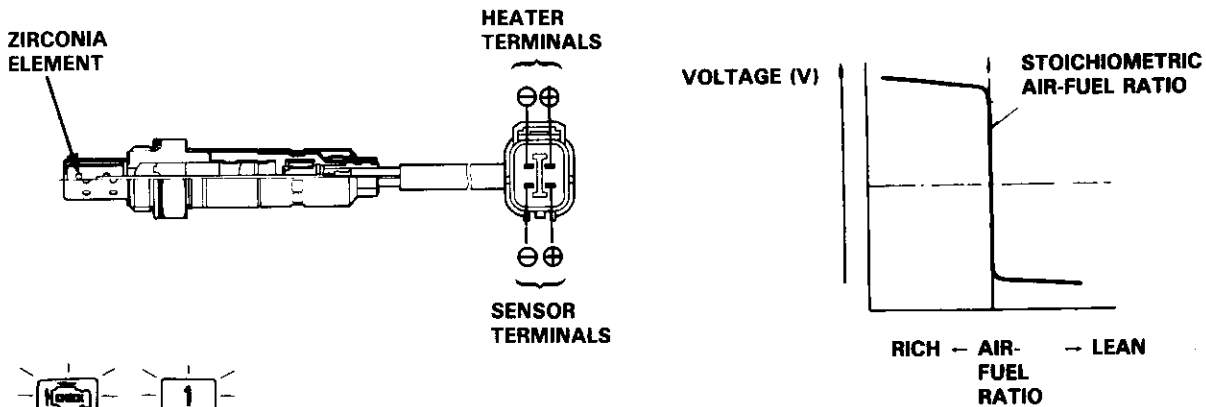

- The MIL has been reported on.
- With service check connector jumped (see page 11-42), code 1 is indicated.

Do the ECM Reset Procedure (see page 11-43).

Warm up engine to normal operating temperature (the radiator fan comes on).

Run engine for 60 seconds.

Road test with the manual transmission in 4th gear (A/T: 2 position). Starting at 1,600 rpm, accelerate using wide open throttle for at least 5 seconds. Then decelerate for at least 5 seconds with the throttle completely closed.

Is the MIL on and does it indicate code 1?

YES

Go to page and perform test for code 43 (see page 11-62).

NO

Intermittent failure, system is OK at this time. Check for poor connections or loose wires at C432 (located at right shock tower), C114 (HO2S) and ECM.

PGM-FI System

Troubleshooting Flowchart — Heated Oxygen Sensor (HO2S) Heater

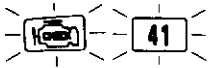

The Malfunction Indicator Lamp (MIL) indicates Diagnostic Trouble Code (DTC) 41: A problem in the Heated Oxygen Sensor (HO2S) Heater circuit.

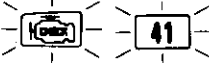

- Engine is running.
- The MIL has been reported on. With service check connector jumped (see page 11-42), code 41 is indicated.

Do the ECM Reset Procedure (see page 11-43).

Start the engine.

Is the MIL on and does it indicate code 41?

NO

YES

Turn the ignition switch OFF.

Disconnect the 4P connector from the HO2S.

Measure resistance between terminals C and D on the HO2S.

Is there 10–40 Ω?

NO

Replace the HO2S.

YES

(To page 11-59)

Intermittent failure, system is OK at this time (test drive may be necessary). Check for poor connections or loose wires at C432 (located at right shock tower), C114 (HO2S) and ECM.

H23A1 engine (USA: Si/Canada: SR)
H22A1 engine (USA: Si VTEC/Canada: SR-V):

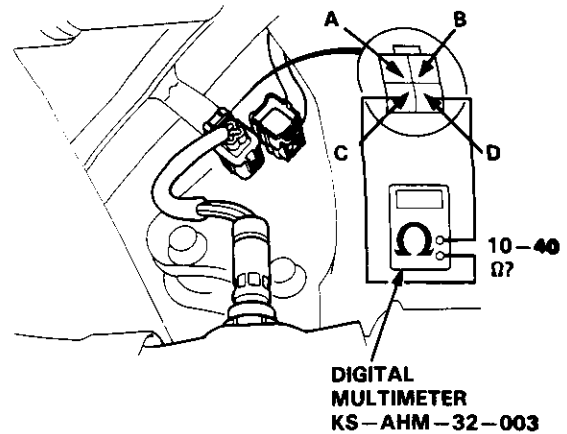

F22A1 engine (S):

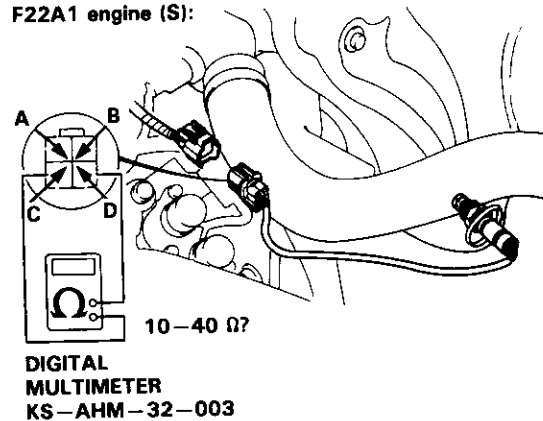



(From page 11-58)

Check for continuity to body ground on terminals C and D of the HO2S.

Is there continuity?

YES

Replace the HO2S.

NO

Check for continuity between terminal D and terminals A and B individually.

Is there continuity?

YES

Replace the HO2S.

NO

Turn the ignition switch ON.

At HO2S harness, measure voltage between YEL/BLK (+) terminal and ORN/WHT (-) terminal.

Is there battery voltage?

YES

Disconnect the "A" connector from the ECM.

NO

Measure voltage between YEL/BLK (+) terminal and body ground.

Is there battery voltage?

NO

Repair open in YEL/BLK wire between HO2S and PGM-FI main relay.

YES

Turn the ignition switch OFF.

(To page 11-60)

H23A1 engine
(USA: Si/Canada: SR),
H22A1 engine
(USA: Si VTEC/Canada: SR-V):

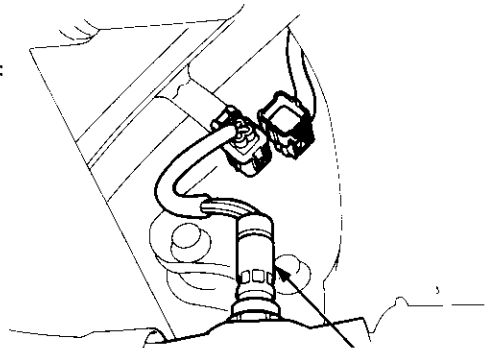

HO2S
45 N·m
(4.5 kg·m,
33 lb·ft)

F22A1 engine (S):

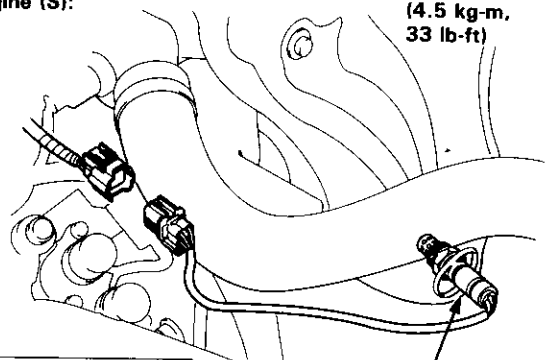

HO2S
45 N·m
(4.5 kg·m, 33 lb·ft)

At HO2S harness, measure voltage between YEL/BLK (+) terminal and ORN/WHT (-) terminal.

Is there battery voltage?

YES

Repair short in ORN/WHT wire between ECM (A6) and HO2S.

NO

Reconnect the HO2S connector.

(To page 11-60)

(cont'd)

PGM-FI System

Troubleshooting Flowchart — Heated Oxygen Sensor (HO2S) Heater (cont'd)

(From page 11-59)

(From page 11-59)

Connect the test harness "A" connector to the main wire harness only, not the ECM (see page 11-45).

Connect an ammeter between terminals A6 (+) and A26 (-)

* Monitor over a 5 minutes period.

Replace the HO2S.

YES

Is the current less than 0.1 A?*

NO

Substitute a known-good ECM and recheck. If symptom/indication goes away, replace the original ECM.

Reconnect the 4P connector to the HO2S.

Connect the test harness "A" connector to the main wire harness only, not the ECM (see page 11-45).

Turn the ignition switch ON.

Measure voltage between A6 (+) terminal and A23 (-) terminal.

Is there battery voltage?

NO

Repair open in ORN/WHT wire between ECM (A6) and HO2S.

YES

Substitute a known-good ECM and recheck. If symptom/indication goes away, replace the original ECM.

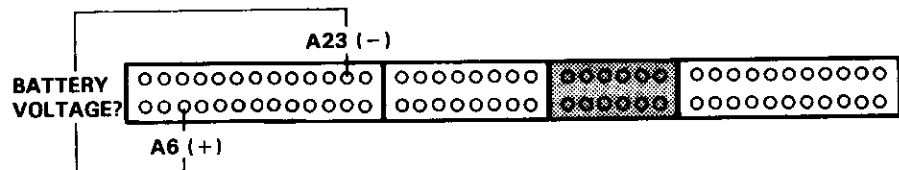

PGM-FI System

Troubleshooting Flowchart — Fuel Supply System

 **43** The Malfunction Indicator Lamp (MIL) indicates Diagnostic Trouble Code (DTC) 43: A problem in the Heated Oxygen Sensor (HO2S) circuit or a problem in the Fuel Supply System.

 **43**

— The MIL has been reported on.
— With service check connector jumped (see page 11-42), code 43 is indicated.

From code 1 trouble-shooting (page 11-56).

Is the code 43 accompanied by the MIL and poor driveability?

YES
Go to Fuel Supply System (see page 11-113).

NO

Do the ECM Reset Procedure (see page 11-43).

Warm up engine to normal operating temperature (the radiator fan comes on).

Hold engine at 3,000 rpm for two minutes.
(A/T: **N** or **P** position.)

Is the MIL on and does it indicate code 43?

NO
Intermittent failure, system is OK at this time (test drive may be necessary).
Check for poor connections or loose wires at C432 (located at right shock tower), C114 (HO2S) and ECM.

YES

Turn the ignition switch OFF.

Connect the test harness between the ECM and connectors (see page 11-45).

With the ignition switch OFF, wait for at least two minutes.

Install a jumper wire on the test harness between A6 and A26.

Turn the ignition switch ON.

Measure voltage between D14 (+) terminal and A26 (-) terminal as soon as the ignition switch is turned on.

(To page 11-63)

NOTE:
• Use DIGITAL MULTIMETER (KS-AHM-32-003) or equivalent.
• Use 2 Volt range.

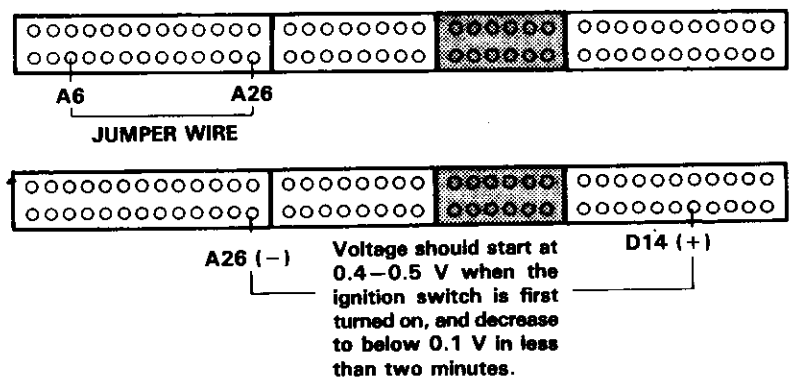



(From page 11-62)

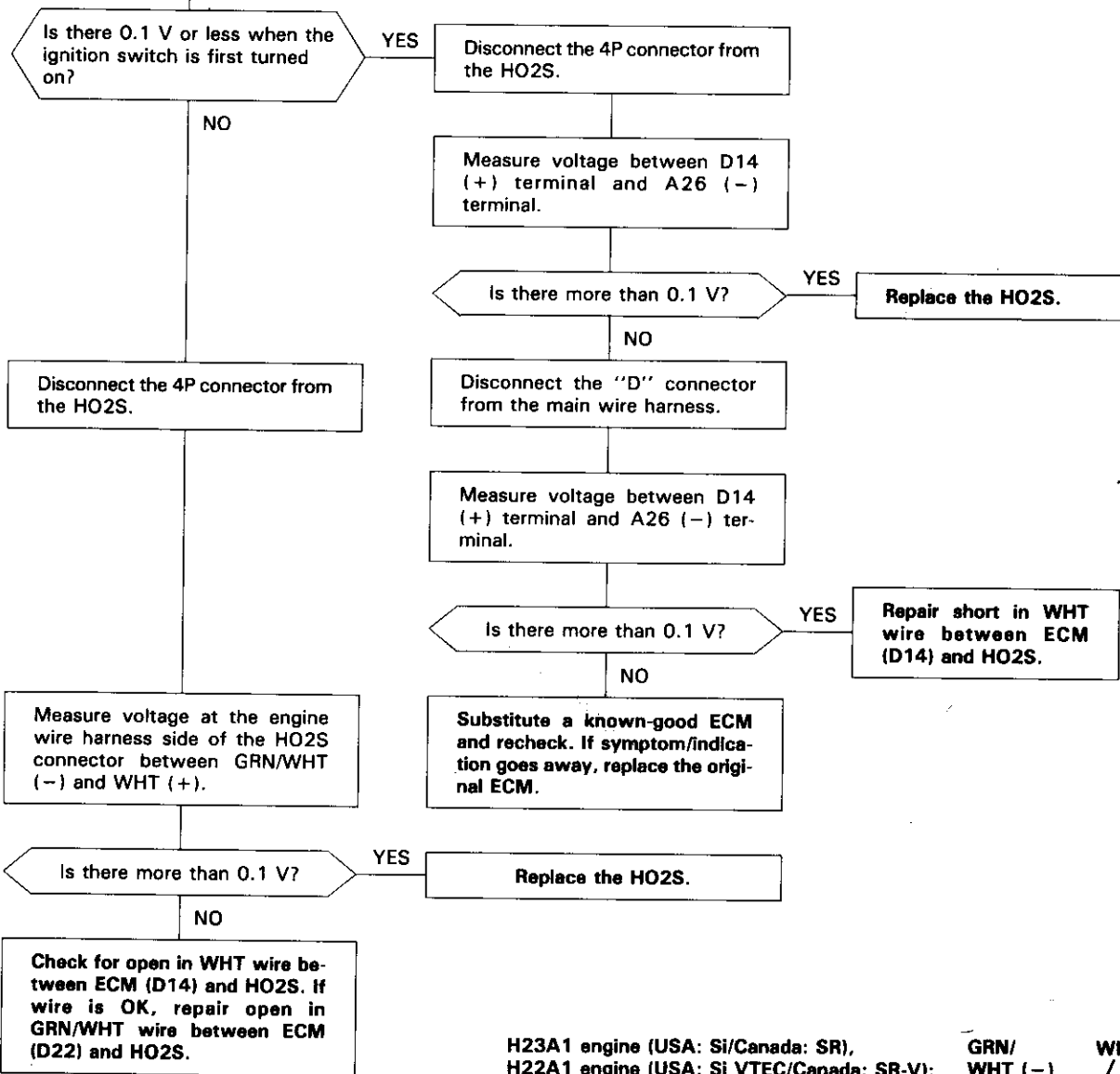

F22A1 engine (S):

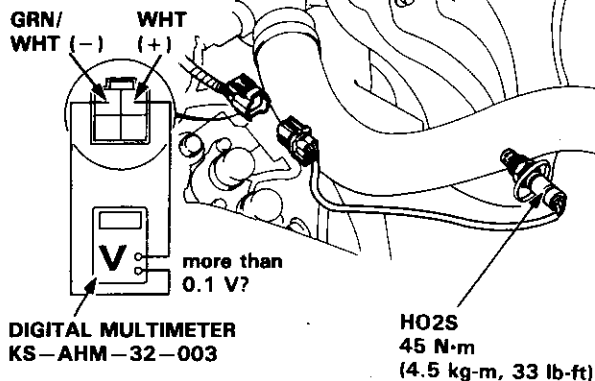

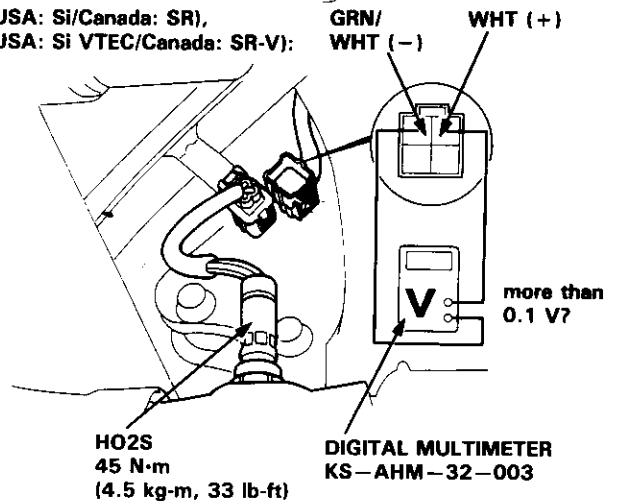

H23A1 engine (USA: Si/Canada: SR),
H22A1 engine (USA: Si VTEC/Canada: SR-V):



PGM-FI System

Troubleshooting Flowchart — Manifold Absolute Pressure (MAP) Sensor

-  **3** The Malfunction Indicator Lamp (MIL) indicates Diagnostic Trouble Code (DTC) 3: An electrical problem in the Manifold Absolute Pressure (MAP) Sensor system.
-  **5** The Malfunction Indicator Lamp (MIL) indicates Diagnostic Trouble Code (DTC) 5: A mechanical problem (vacuum leak) in the Manifold Absolute Pressure (MAP) Sensor System.

The MAP sensor converts manifold absolute pressure into electrical signals and inputs the ECM.

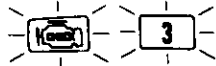
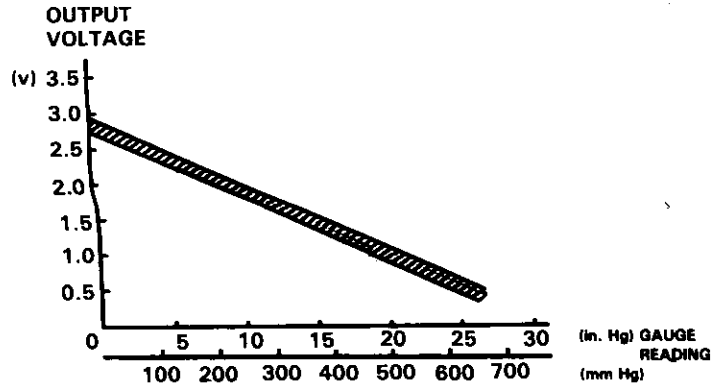
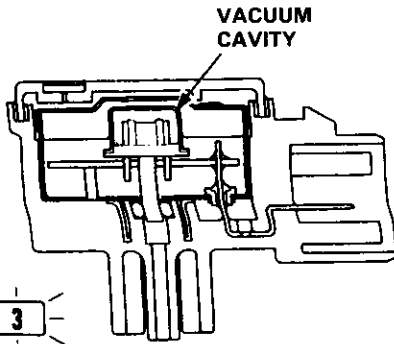

— Engine is warm and running.
 — The MIL has been reported on.
 — With service check connector jumped (see page 11-42), code 3 is indicated.

Do the ECM Reset Procedure (see page 11-43).

Start the engine and allow it to idle.

Is the MIL on and does it indicate code 3?

NO

Intermittent failure, system is OK at this time (test drive may be necessary).
 Check for poor connections or loose wires at C463 (located under left side of dash), C320 (MAP sensor) and ECM.

YES

Turn the ignition switch OFF.

Disconnect the 3P connector from the MAP sensor.

Turn the ignition switch ON.

(To page 11-65)

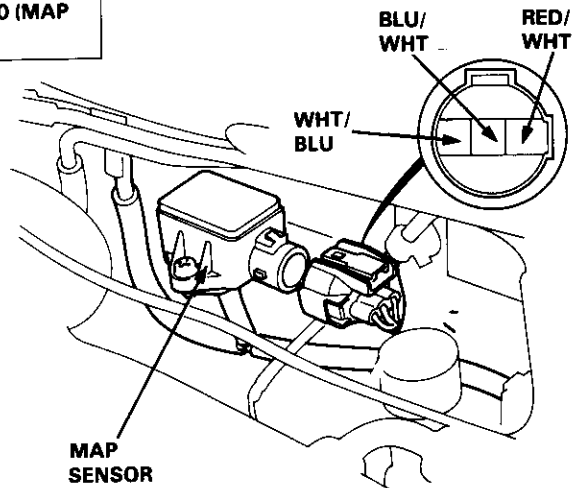



(From page 11-64)

Measure voltage between RED/WHT (+) terminal and body ground.

Is there approx. 5 V?

NO

Turn the ignition switch OFF.

Connect the test harness "D" connector to the ECM only, not to the main wire harness (see page 11-45).

Turn the ignition switch ON.

Measure voltage between D19 (+) terminal and D21 (-) terminal.

Is there approx. 5 V?

NO

Repair open in RED/WHT wire between ECM (D19) and MAP sensor.

Substitute a known-good ECM and recheck. If symptom/indication goes away, replace the original ECM.

(To page 11-66)

5 V?

D19 (+) D21 (-)

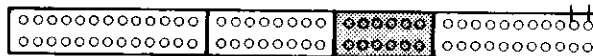

Measure voltage between RED/WHT (+) terminal and BLU/WHT (-) terminal.

Is there approx. 5 V?

NO

Repair open in BLU/WHT wire between ECM (D21) and MAP sensor.

YES

Measure voltage between WHT/BLU (+) terminal and BLU/WHT (-) terminal.

Is there approx. 5 V?

YES

Turn the ignition switch OFF.

Reconnect the 3P connector to the MAP sensor.

Connect the test harness between the ECM and connector (see page 11-45).

Turn the ignition switch ON.

(To page 11-66)

(cont'd)

PGM-FI System

Troubleshooting Flowchart – Manifold Absolute Pressure (MAP) Sensor (cont'd)

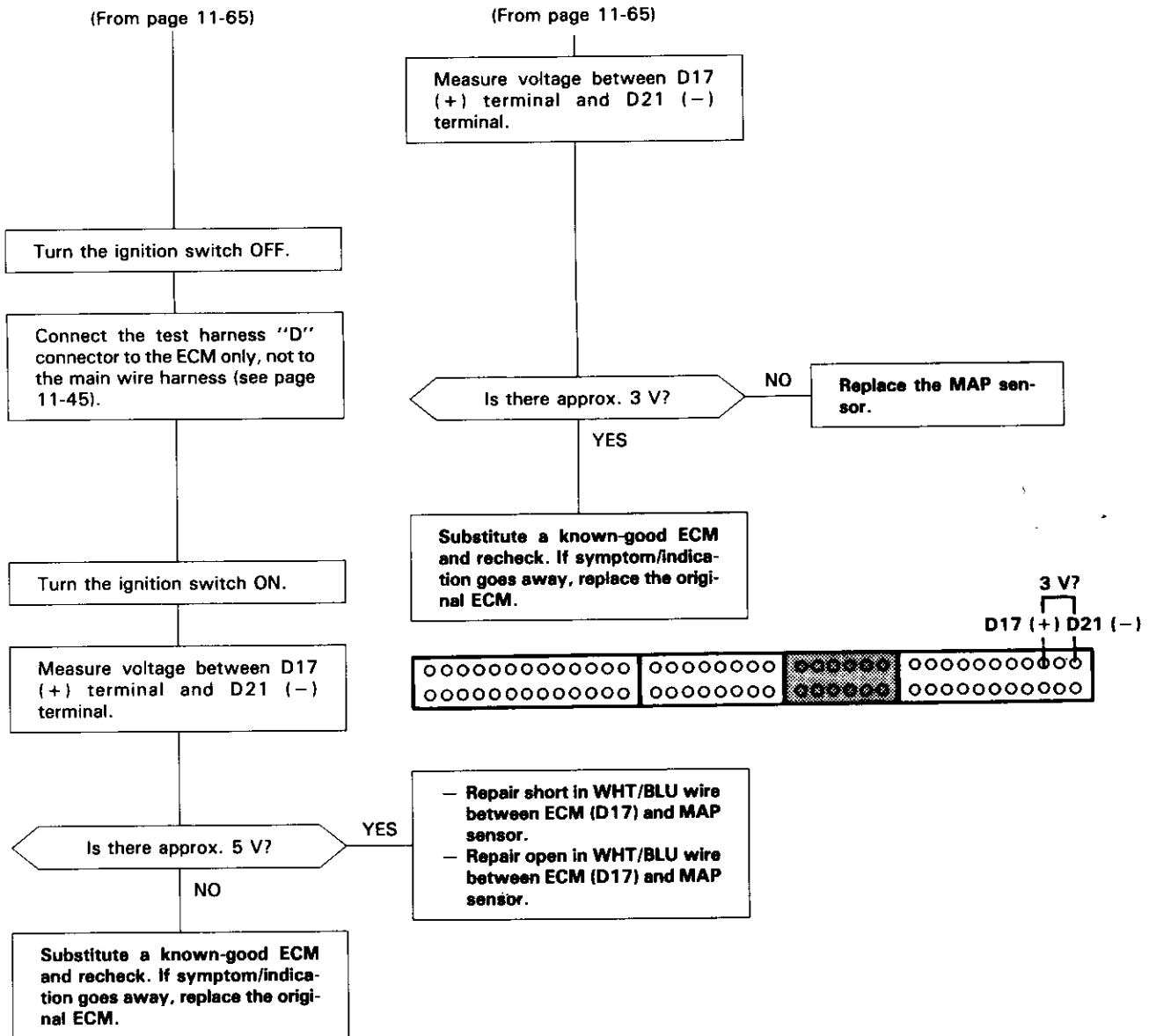

(cont'd)

PGM-FI System

Troubleshooting Flowchart — Manifold Absolute Pressure (MAP) Sensor (cont'd) -



— The MIL has been reported on.
 — With service check connector jumped (see page 11-42), code 5 is indicated.

Do the ECM Reset Procedure (see page 11-43).

Start the engine and keep engine speed at 2,000 rpm for one minute with the manual transmission in neutral (A/T: **P** or **N** position).

Is the MIL on and does it indicate code 5?

NO

- Intermittent failure, system is OK at this time (test drive may be necessary).
- Check vacuum hoses, pipes and connections.
- Make sure all connectors are secure.

YES

Turn the ignition switch OFF.

Disconnect #21 hose from the throttle body, connect vacuum pump to the hose and apply vacuum.

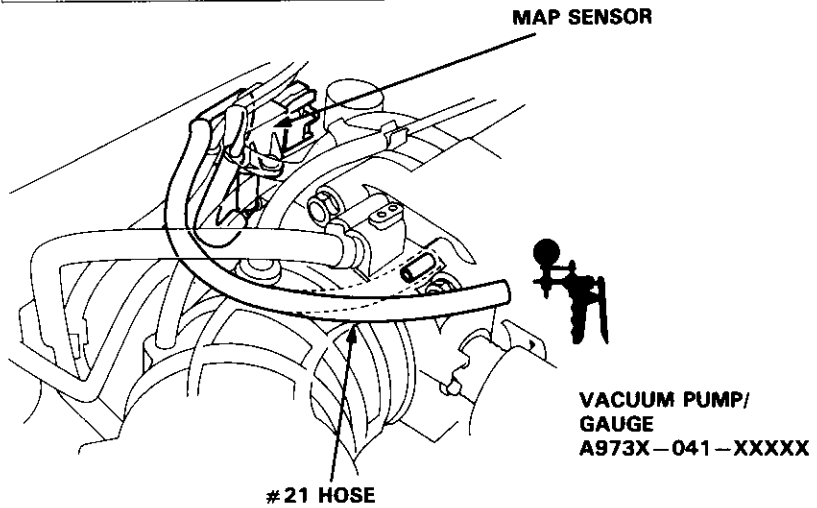

Does it hold vacuum?

NO

Connect a vacuum pump to the MAP sensor and apply vacuum.

YES

Does it hold vacuum?

NO

Replace the MAP sensor.

YES

Connect a T-fitting from a vacuum gauge between the throttle body and #21 hose.

Repair vacuum leak in hose routing between MAP sensor and throttle body.

(To page 11-69)



(From page 11-68)

Start the engine.

Is there manifold vacuum?

NO

Remove restriction from throttle body.

YES

Turn the ignition switch OFF.

Connect the test harness between the ECM and connectors (see page 11-45).

Turn the ignition switch ON.

Measure voltage between D17 (+) terminal and D21 (-) terminal.

Is there approx. 3 V?

NO

Replace the MAP sensor.

YES

Start the engine and allow it to idle.

Is there approx. 1 V?

NO

Replace the MAP sensor.

YES

Substitute a known-good ECM and recheck. If symptom/indication goes away, replace the original ECM.

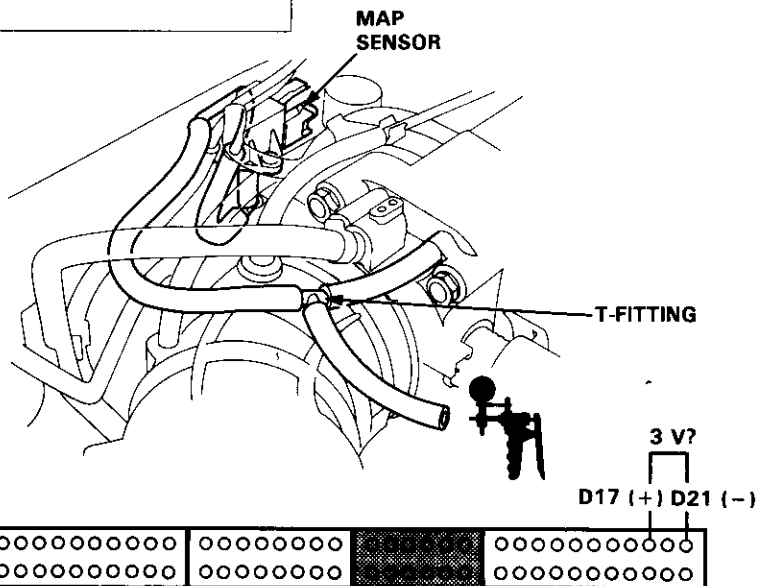

PGM-FI System

Troubleshooting Flowchart — TDC/CKP/CYP Sensor

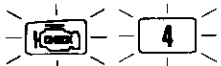

The Malfunction Indicator Lamp (MIL) indicates Diagnostic Trouble Code (DTC) 4: A problem in the Crankshaft Position (CKP) Sensor circuit.

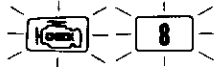

The Malfunction Indicator Lamp (MIL) indicates Diagnostic Trouble Code (DTC) 8: A problem in the Top Dead Center (TDC) Sensor circuit.

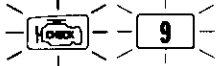

The Malfunction Indicator Lamp (MIL) indicates Diagnostic Trouble Code (DTC) 9: A problem in the Cylinder Position (CYP) Sensor circuit.

The CKP Sensor determines timing for fuel injection and ignition of each cylinder and also detects engine speed. The TDC Sensor determines ignition timing at start-up (cranking) and when crank angle is abnormal. The CYP Sensor detects the position of No. 1 cylinder for sequential fuel injection to each cylinder.

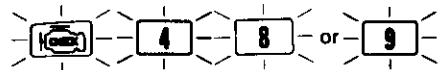

- The MIL has been reported on.
- With service check connector jumped (see page 11-42), code 4, 8 and/or 9 are indicated.

Do the ECM Reset procedure (see page 11-43).

Start the engine.

Is the MIL on and does it indicate code 4, 8 and/or 9?

NO

Intermittent failure, system is OK at this time (test drive may be necessary).
Check for poor connections or loose wires at C425 (located at right shock tower), C125 (TDC/CKP/CYP sensor) and ECM.

YES

Turn the ignition switch OFF.

Disconnect the 8P connector from the TDC/CKP/CYP sensor.

(To page 11-71)

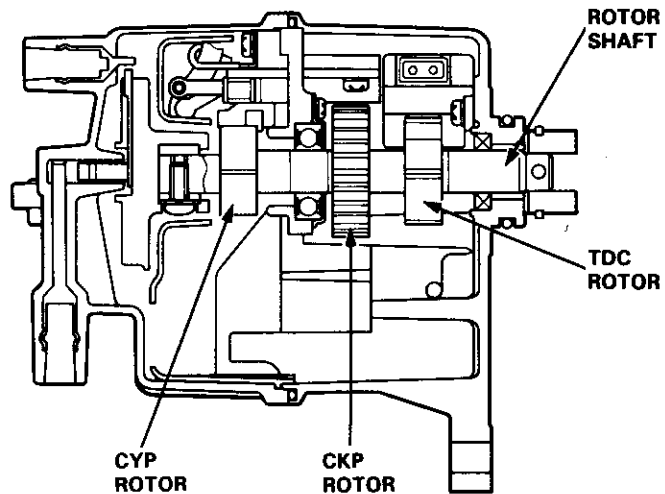

F22A1 engine (S):

View from terminal side

A	B	C	D
E	F	G	H

H23A1 engine (USA: Si/Canada: SR),
H22A1 engine
(USA: Si VTEC/Canada SR-V):

View from terminal side

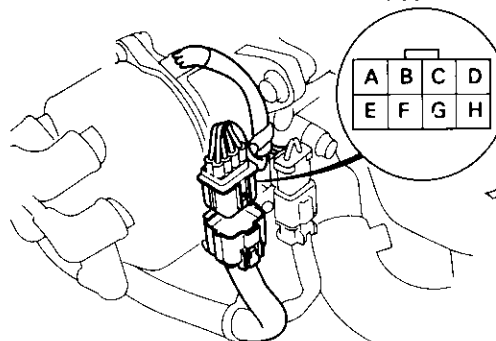

A	B	C	D
E	F	G	H

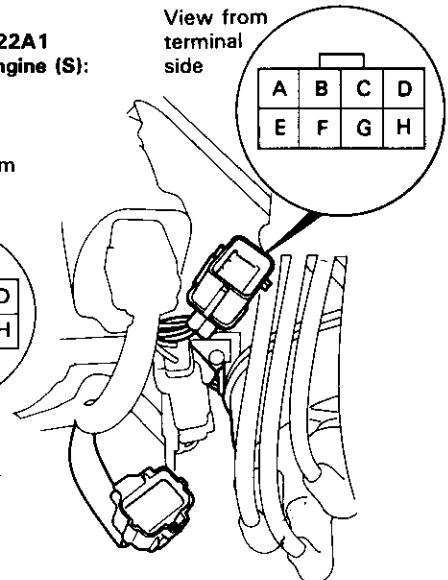



(From page 11-70)

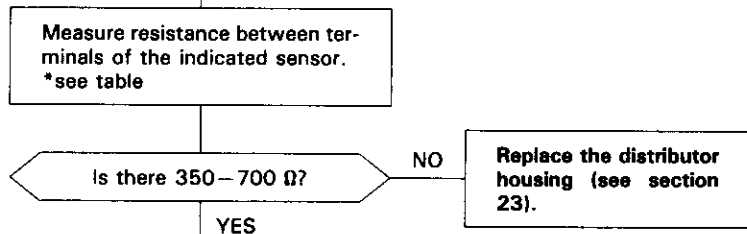

*,

SENSOR	DTC	SENSOR TERMINAL	ECM TERMINAL	WIRE COLOR
CKP	4	B	B15	BLU/GRN
		F	B16	BLU/YEL
TDC	8	C	B13	ORN/BLU
		G	B14	WHT/BLU
CYP	9	D	B11	ORN
		H	B12	WHT

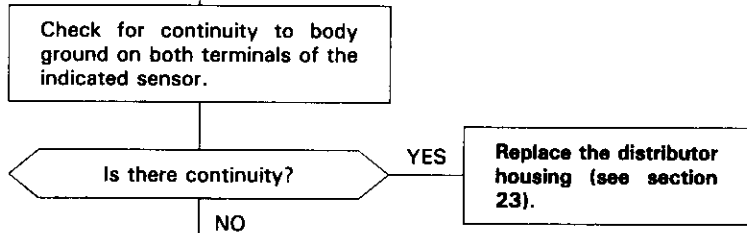

NO

Reconnect the connector.

Connect the test harness to the main wire harness only, not to the ECM (see page 11-45).

Measure resistance between terminals of the indicated sensor on test harness.
*see table

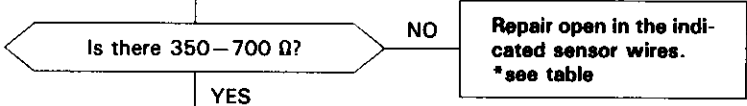
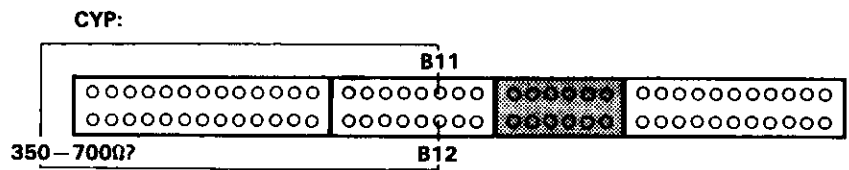
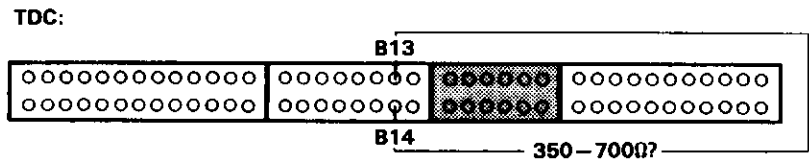
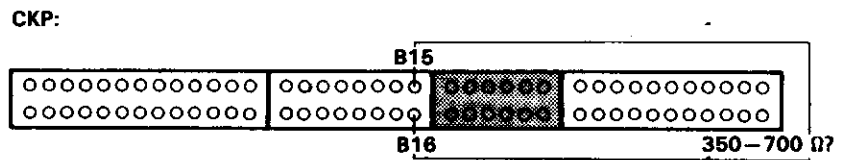

YES

Check for continuity to body ground on B15, B13 or B11 terminals.

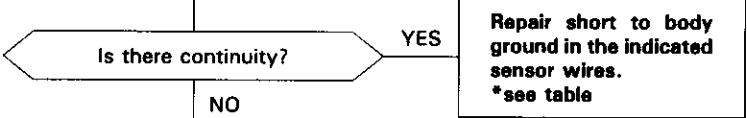

NO

Substitute a known-good ECM and recheck. If symptom/indication goes away, replace the original ECM.

PGM-FI System

Troubleshooting Flowchart — Engine Coolant Temperature (ECT) Sensor —

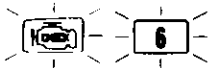

The Malfunction Indicator Lamp (MIL) indicates Diagnostic Trouble Code (DTC) 6: A problem in the Engine Coolant Temperature (ECT) Sensor circuit.

The ECT Sensor is a temperature dependant resistor (thermistor). The resistance of the thermistor decreases as the engine coolant temperature increases as shown below.

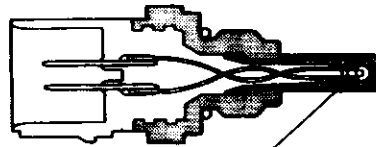

THERMISTOR

RESISTANCE (KΩ)

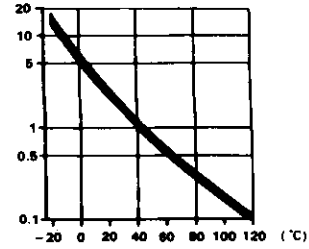

ENGINE COOLANT TEMPERATURE

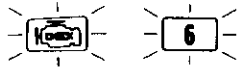

- The MIL has been reported on.
- With service check connector jumped (see page 11-42), code 6 is indicated.

Do the ECM Reset Procedure (see page 11-43).

Turn the ignition switch ON.

Is the MIL on and does it indicate code 6?

NO

Intermittent failure, system is OK at this time (test drive may be necessary).
Check for poor connections or loose wires at C425, C426 (located at right shock tower), C122 (ECT sensor), A/T: C411 (TCM) and ECM.

YES

Warm up engine to normal operating temperature (the radiator fan comes on).

Turn the ignition switch OFF.

Disconnect the 2P connector from the ECT sensor.

Measure resistance between the 2 terminals on the ECT sensor.

Is there 200–400 Ω?

NO

Replace the ECT sensor.

YES

(To page 11-73)



(From page 11-72)

Turn the ignition switch ON.

Measure voltage between YEL/BLU and body ground.

Is there approx. 5 V?

YES
Measure voltage between YEL/BLU (+) terminal and GRN/WHT (-) terminal.

NO
Turn the ignition switch OFF.

Is there approx. 5 V?

NO
Repair open in GRN/WHT wire between ECM (D22) and ECT sensor.

A/T only
Disconnect the 22P connector from the TCM.

Turn the ignition switch ON.

Is there approx. 5 V?

YES
Replace the TCM.

NO
Turn the ignition switch OFF.

YES
Substitute a known-good ECM and recheck. If symptom/indication goes away, replace the original ECM.

Connect the test harness "D" connector to the ECM only, not to the main wire harness (see page 11-45).

Turn the ignition switch ON.

Measure voltage between D13 (+) terminal and D22 (-) terminal.

Is there approx. 5 V?

YES
Repair open or short in YEL/BLU wire between ECM (D13) and ECT sensor.

NO
Substitute a known-good ECM and recheck. If symptom/indication goes away, replace the original ECM.

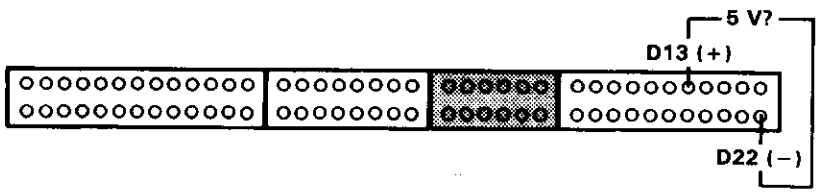
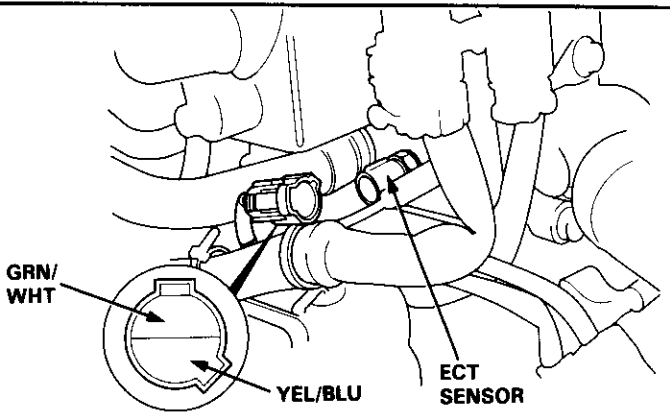

PGM-FI System

Troubleshooting Flowchart — Throttle Position (TP) Sensor

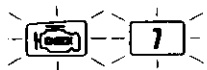

The Malfunction Indicator Lamp (MIL) indicates Diagnostic Trouble Code (DTC) 7: A problem in the Throttle Position (TP) Sensor circuit.

The TP Sensor is a potentiometer. It is connected to the throttle valve shaft. As the throttle position changes, the TP Sensor varies the voltage signal to the ECM.

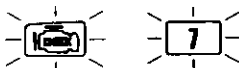
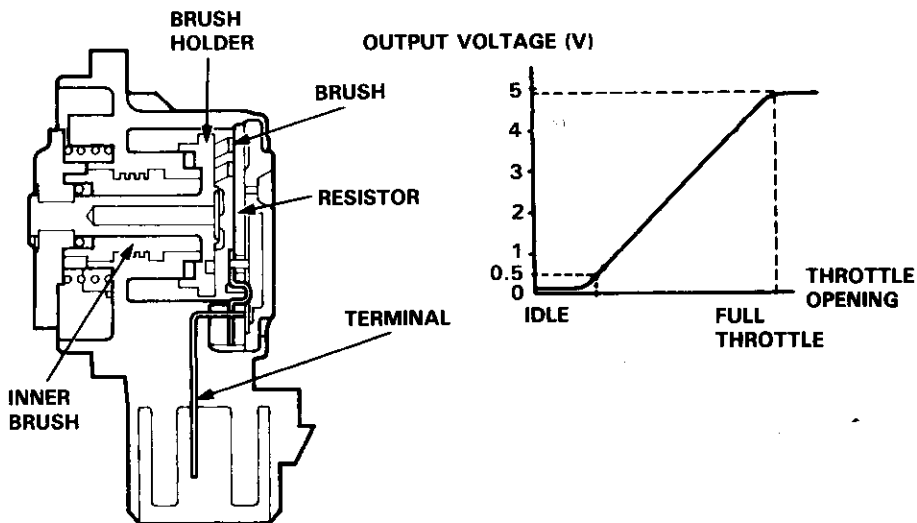

- Engine is running.
- The MIL has been reported on.
- With service check connector jumped (see page 11-42), code 7 is indicated.

Do the ECM Reset Procedure (see page 11-43).

Start the engine.

Is the MIL on and does it indicate code 7?

NO

Intermittent failure, system is OK at this time (test drive may be necessary).
Check for poor connections or loose wires at C425, C433 (located at right shock tower), C113 (TP sensor), A/T: C411 (TCM) and ECM.

YES

Turn the ignition switch OFF.

Disconnect the 3P connector from the TP sensor.

Turn the ignition switch ON.

Measure voltage between YEL/WHT (+) terminal and GRN/WHT (-) terminal.

Is there approx. 5 V?

NO

Measure voltage between YEL/WHT (+) terminal and body ground.

YES

(To page 11-75)

(To page 11-75)

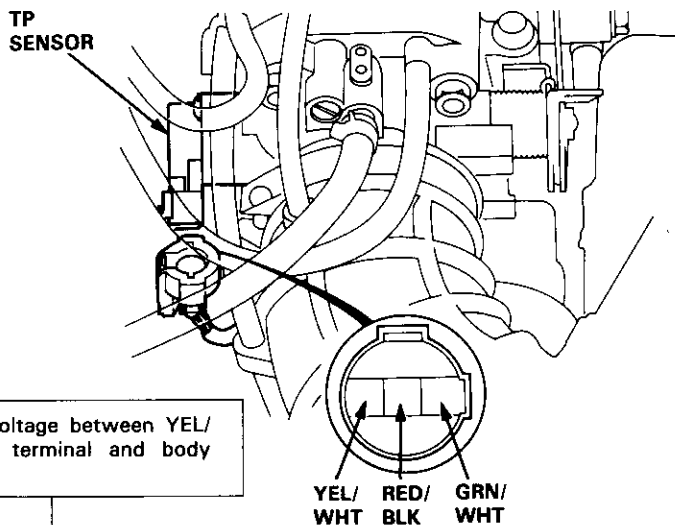



(From page 11-74)

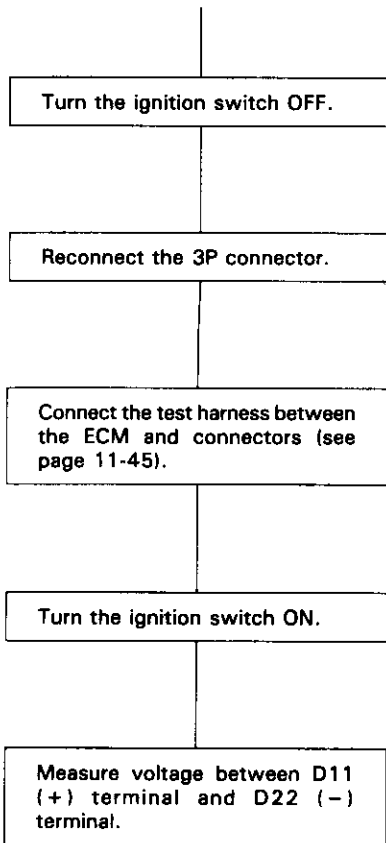

(From page 11-74)

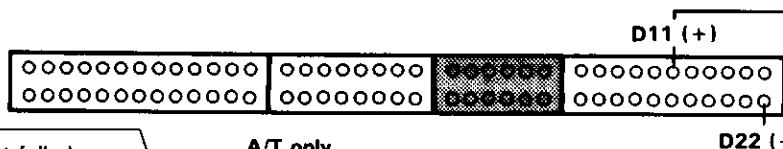
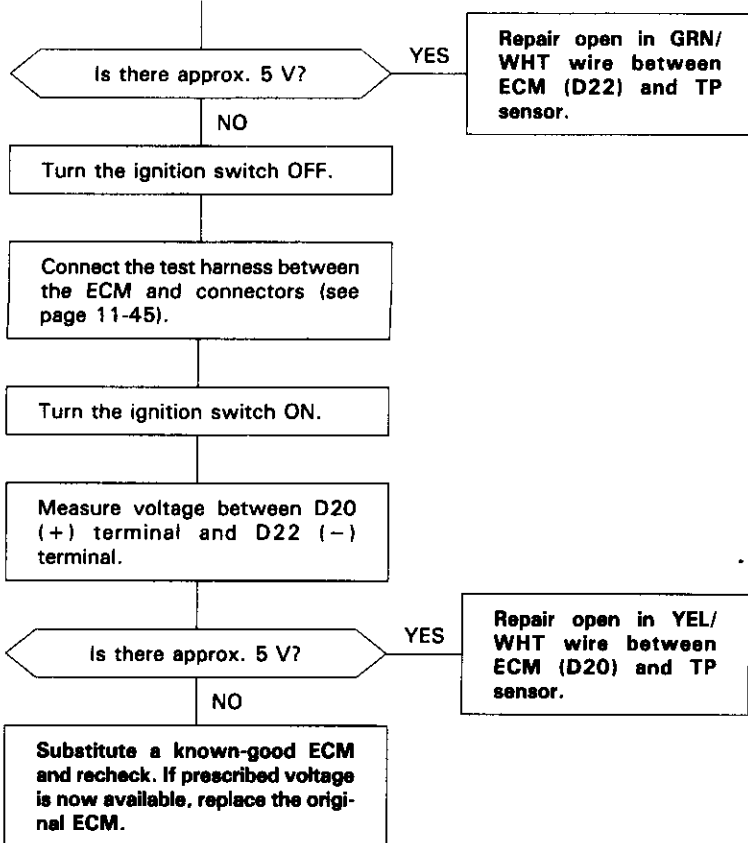

D20 (+) D22 (-)
5 V?

0.5 V at full close throttle?
4.5 V at full open throttle?

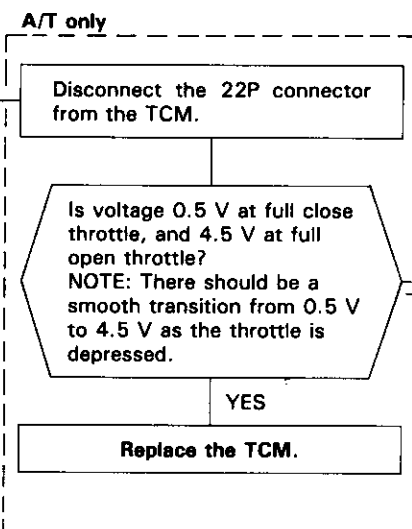
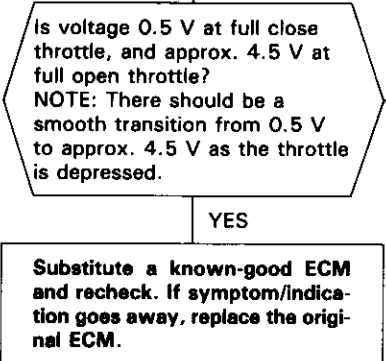

- Replace the TP sensor.
- Repair open or short in RED/BLK wire between ECM (D11), TCM and TP sensor.

PGM-FI System

Troubleshooting Flowchart — Intake Air Temperature (IAT) Sensor



10

The Malfunction Indicator Lamp (MIL) indicates Diagnostic Trouble Code (DTC) 10: A problem in the Intake Air Temperature (IAT) Sensor circuit.

The IAT Sensor is a temperature dependant resistor (thermistor). The resistance of the thermistor decreases as the intake air temperature increases as shown below.

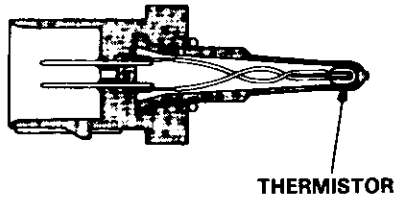

RESISTANCE (kΩ)

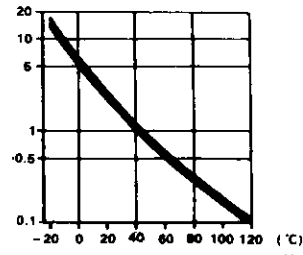

INTAKE AIR TEMPERATURE

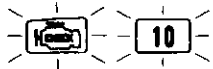
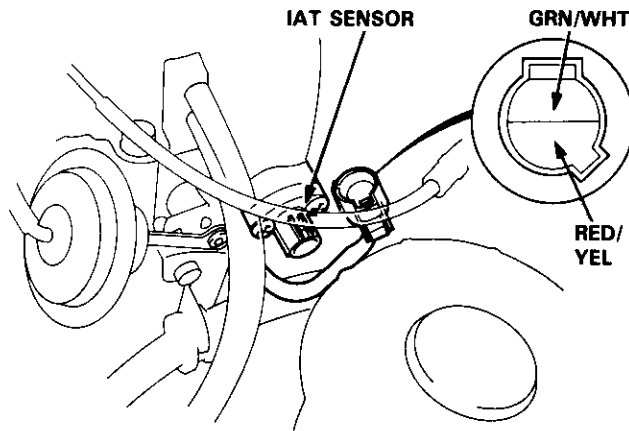

10

- The MIL has been reported on.
- With service check connector jumped (see page 11-42), code 10 is indicated.

Do the ECM Reset Procedure (see page 11-43).

Turn the ignition switch ON.

Is the MIL on and does it indicate code 10?

NO

Intermittent failure, system is OK at this time (test drive may be necessary).
Check for poor connections or loose wires at C425, C426 (located at right shock tower), C108 (IAT sensor) and ECM.

YES

Turn the ignition switch OFF.

Disconnect the 2P connector from the IAT sensor.

Measure resistance between the 2 terminals on the IAT sensor.

Is there 0.4—4.0 kΩ?

NO

Replace the IAT sensor.

YES

(To page 11-77)



(From page 11-76)

Turn the ignition switch ON.

Measure voltage between RED/
YEL (+) terminal and body
ground.

Is there approx. 5 V?

YES

Measure voltage between RED/
YEL (+) terminal and GRN/WHT
(-) terminal.

NO

Turn the ignition switch OFF.

Is there approx. 5 V?

NO

Repair open in GRN/
WHT wire between
ECM (D22) and IAT
sensor.

YES

Substitute a known-good ECM
and recheck. If symptom/indica-
tion goes away, replace the origi-
nal ECM.

Connect the test harness "D"
connector to the ECM only, not to
the main wire harness (see page
11-45).

Turn the ignition switch ON.

Measure voltage between D15
(+) terminal and D22 (-)
terminal.

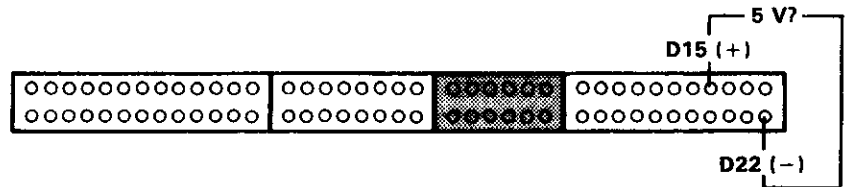

Is there approx. 5 V?

YES

Repair open or short in RED/YEL
wire between ECM (D15) and IAT
sensor.

NO

Substitute a known-good ECM
and recheck. If symptom/indica-
tion goes away, replace the origi-
nal ECM.

PGM-FI System

Troubleshooting Flowchart — Barometric Pressure (BARO) Sensor

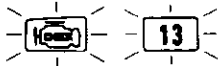

The Malfunction Indicator Lamp (MIL) indicates Diagnostic Trouble Code (DTC) 13: A problem in the Barometric Pressure (BARO) Sensor.

The BARO Sensor is built into the ECM.

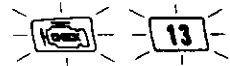

- The MIL has been reported on.
- With service check connector jumped (see page 11-42), code 13 is indicated.

Do the ECM Reset Procedure (see page 11-43).

Turn the ignition switch ON.

Is the MIL on and does it indicate code 13?

NO

Intermittent failure, system is OK at this time (test drive may be necessary).

YES

Substitute a known-good ECM and recheck. If symptom/indication goes away, replace the original ECM.

PGM-FI System

Troubleshooting Flowchart — Ignition Output Signal

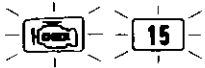

The Malfunction Indicator Lamp (MIL) indicates Diagnostic Trouble Code (DTC) 15: A problem in the Ignition Output Signal circuit.

- The MIL has been reported on.
- With service check connector jumped (see page 11-42), code 15 is indicated.

Do the ECM Reset Procedure (see page 11-43).

Start the engine.

Is the MIL on and does it indicate code 15?

NO

Intermittent failure, system is OK at this time (test drive may be necessary).
Check for poor connections or loose wires at C433 (located at right shock tower), C125 (Ignition Control Module (ICM)) and ECM.

YES

Turn the ignition switch OFF.

Disconnect the 2P connector from the distributor.

Turn the ignition switch ON.

Measure voltage between YEL (+) terminal and body ground.

Is there battery voltage?

NO

YES

(To page 11-81)

(To page 11-81)

H23A1 engine (USA: Si/Canada: SR),
H22A1 engine (USA: Si VTEC/ Canada: SR-V):

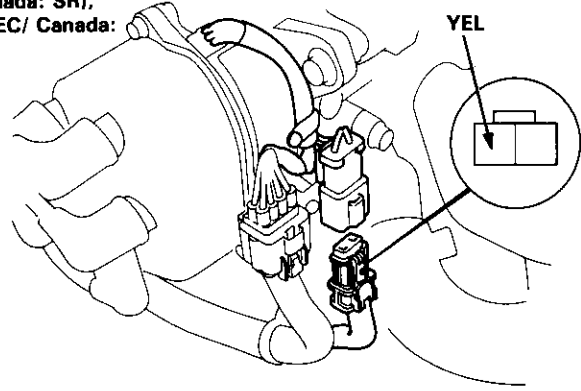

NOTE: If the engine won't start, it may take 20 seconds of cranking to set the code.

F22A1 engine (S):

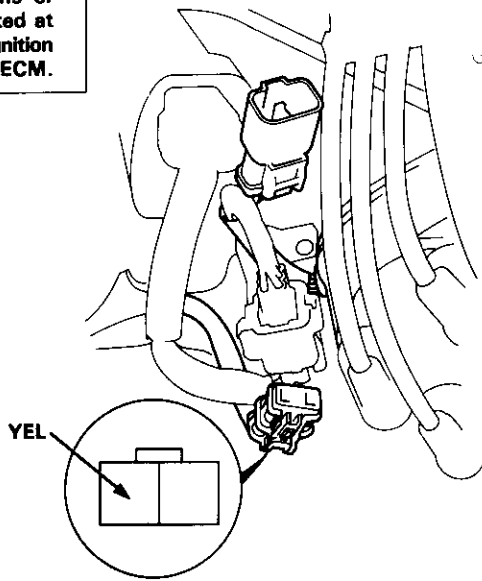

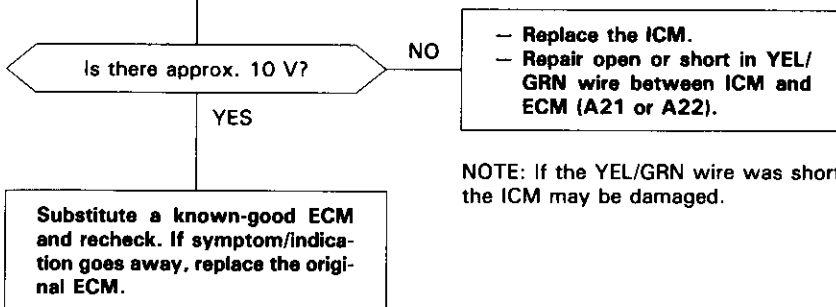
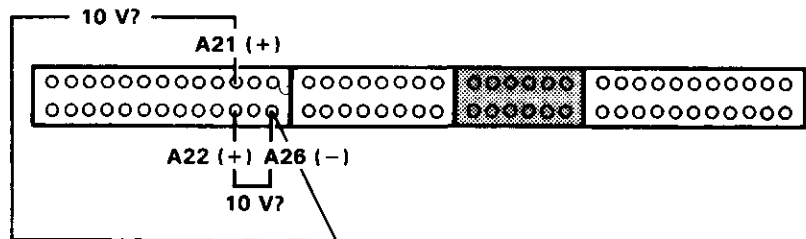
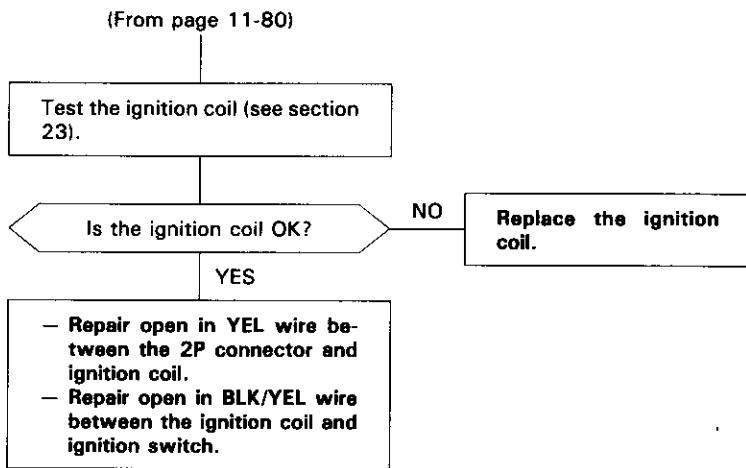
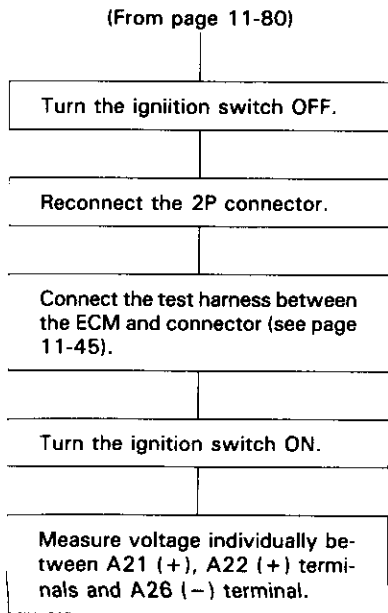

NOTE: If the YEL/GRN wire was shorted, the ICM may be damaged.

PGM-FI System

Troubleshooting Flowchart — Vehicle Speed Sensor (VSS)

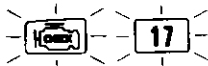

The Malfunction Indicator Lamp (MIL) indicates Diagnostic Trouble Code (DTC) 17: A problem in the Vehicle Speed Sensor (VSS) circuit.

The VSS generates a pulsing signal when the front wheels turn.

— The MIL has been reported on.
— With service check connector jumped (see page 11-42), code 17 is indicated.

Do the ECM Reset Procedure (see page 11-43).

Road test necessary.
With manual transmission in 2nd gear (A/T: **2**) position) accelerate to 4,000 rpm, then decelerate to 1,500 rpm with throttle fully closed.

Is the MIL on and does it indicate code 17?

NO

Intermittent failure, system is OK at this time.
Check for poor connections or loose wires at C433 (located at right shock tower), C115 (VSS) and ECM.

YES

Block rear wheels and set the parking brake. Jack up the front of the car and support with safety stands.

⚠ WARNING Block rear wheel before jacking up front of car.

Turn the ignition switch OFF.

Connect the test harness between the ECM and connectors (see page 11-45).

Turn the ignition switch ON.

Block the right front wheel and slowly rotate left front wheel and measure voltage between B10 (+) terminal and A26 (-) terminal.

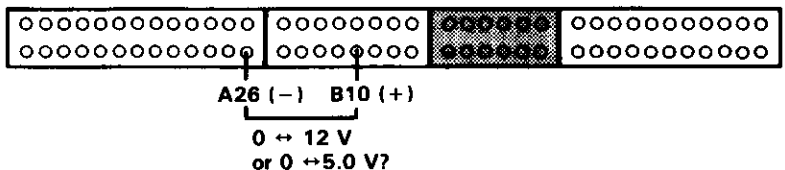

NOTE: Transmission in **N** position (A/T).

Does voltage pulse 0 V and 12 V (H22A1 engine (USA: Si VTEC/Canada: SR-V) 5.0 V)?

NO

Turn the ignition switch OFF.

YES

Substitute a known-good ECM and recheck. If symptom/indication goes away, replace the original ECM.

(To page 11-83)



(From page 11-82)

Disconnect the B connector from the ECM only, not the main wire harness.

Turn the ignition switch ON.

Block the right front wheel and slowly rotate left front wheel and measure voltage between B10 (+) terminal and A26 (-) terminal.

Does voltage pulse 0 V and 12 V (H22A1 engine (USA: Si VTEC/Canada: SR-V): 5.0 V)?

NO

YES

Substitute a known-good ECM and recheck. If symptom/indication goes away, replace the original ECM.

- Repair short in ORN wire between ECM (B10) and the VSS, Transmission Control Module, speedometer, 4WS control unit, or cruise control unit.
- Repair open in ORN wire between ECM (B10) and VSS.
- If wire is OK, test the VSS (see section 23).

PGM-FI System

Troubleshooting Flowchart — Electrical Load Detector (ELD)

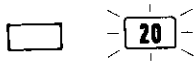

The Malfunction Indicator Lamp (MIL) indicates Diagnostic Trouble Code (DTC) 20: A problem in the Electrical Load Detector (ELD) circuit.

With service check connector jumped (see page 11-42), code 20 is indicated.

Do the ECM Reset procedure (see page 11-43).

Start engine and keep engine rpm at idle.
Turn on headlights.

Does the MIL indicate code 20?

NO

Intermittent failure, system is OK at this time (test drive may be necessary).
Check for poor connections or loose wires at C420 (ELD) and ECM.

YES

Turn the ignition switch OFF.

Remove the under-hood fuse/relay box and remove the fuse/relay box lower cover.

Disconnect the 3P connector from the ELD.

Turn the ignition switch ON.

Measure voltage between BLK/YEL (+) terminal and BLK (-) terminal.

Is there battery voltage?

NO

Measure voltage between BLK/YEL (+) terminal and body ground.

Is there battery voltage?

YES

Repair open in BLK wire between the 3P connector and G403 (located under middle of dash).

NO

Repair open in BLK/YEL wire between ECU (ECM) (15 A) fuse (in the under-dash fuse/relay box) and the 3P connector.

(To page 11-85)

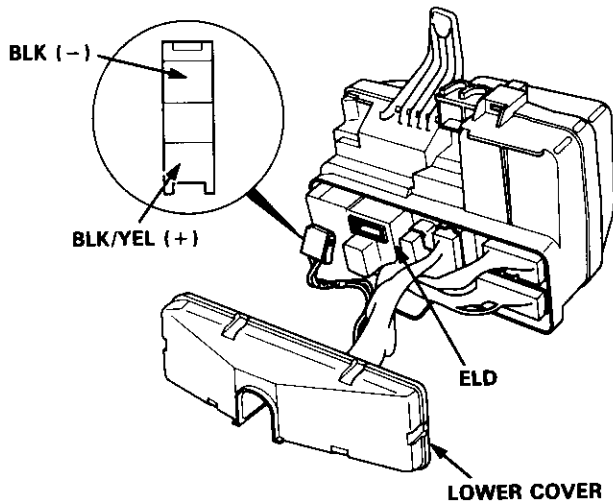



(From page 11-84)

Measure voltage between GRN/
BLK terminal and body ground.

Is there 4.5–5.0 V?

NO

Repair open or short in GRN/BLK
wire between ECM (D10) and the
3P connector.
If wire is OK, substitute a known-
good ECM and recheck.

YES

Turn the ignition switch OFF.

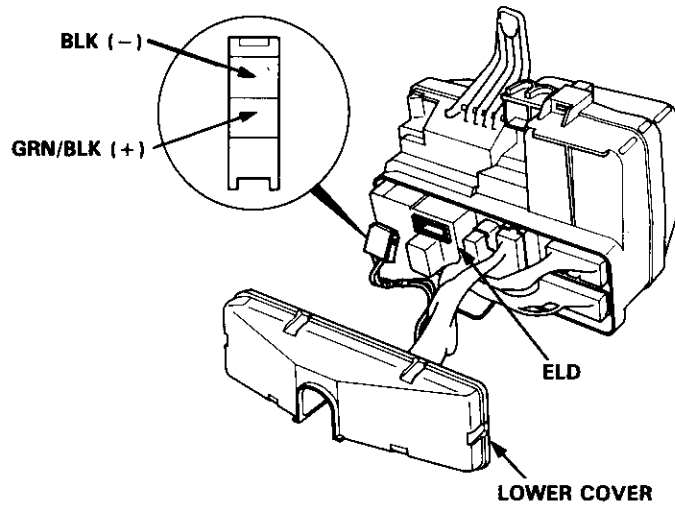

Connect the 3P connector to the
ELD.

Connect the test harness between
the ECM and connectors (see
page 11-45).

(To page 11-86)

(cont'd)

PGM-FI System

Troubleshooting Flowchart — Electrical Load Detector (ELD) (cont'd)

(From page 11-85)

Start the engine and allow it to idle.

Under the conditions listed in the chart to the right, measure voltage between D10 (+) terminal and A26 (-) terminal.

Condition	Voltage
Headlight switch, first position (•)	1.5–3.0 V
Headlight switch, second position (●)	1.0–2.0 V

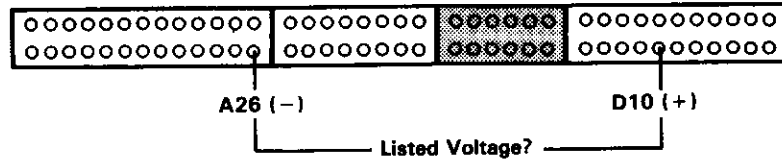

Is the voltage listed in the chart available?

NO

Replace the ELD.

YES

Substitute a known-good ECM and recheck. If symptom/indication goes away, replace the original ECM.

PGM-FI System

Troubleshooting Flowchart — Knock Sensor (KS) [Except F22A1 engine(S)] —

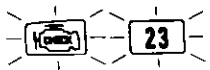

The Malfunction Indicator Lamp (MIL) indicates Diagnostic Trouble Code (DTC) 23: A problem in the Knock Sensor (KS) circuit.

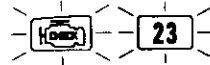

- The MIL has been reported on.
- With service check connector jumped (see page 11-42), code 23 is indicated.

Do the ECM Reset Procedure (see page 11-43).

Warm up the engine to normal operating temperature (the radiator fan comes on).

Hold engine at 3,000–4,000 rpm for 10 seconds with manual transmission in neutral (A/T: **N** or **P** position).

Is the MIL on and does it indicate code 23?

NO

Intermittent failure, system is OK at this time (test drive may be necessary). Check for poor connections or loose wires at C432 (located at right shock tower), C112 (KS) and ECM.

YES

Turn the ignition switch OFF.

Connect the test harness to the engine wire harness only, not to the ECM (see page 11-45).

Disconnect the 2P connector from the KS.

Check for continuity between D3 terminal and body ground.

Is there continuity?

YES

Repair short in RED/BLU wire between ECM (D3) and the KS.

NO

(To page 11-89)

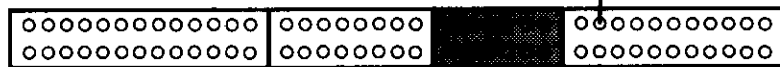

D3

Continuity?



(From page 11-88)

Check for continuity on RED/BLU wire between D3 terminal and 2P connector of engine wire harness.

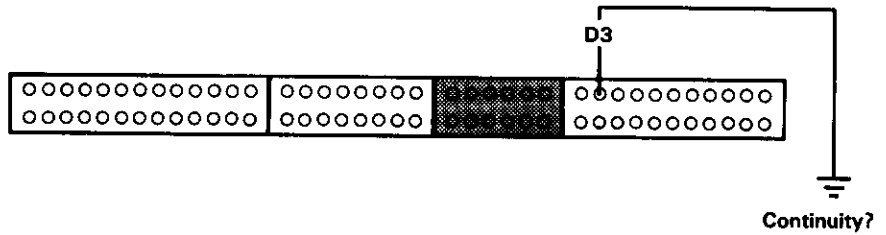

Is there continuity?

NO

Repair open in RED/BLU wire between ECM (D3) and the KS.

YES

Substitute a known-good KS and recheck.

Warm up the engine to normal operating temperature (the radiator fan comes on).

Hold engine at 3,000–4,000 rpm for 10 seconds with manual transmission in neutral (A/T: **N** or **P** position).

Is the MIL on and does it indicate code 23?

NO

Replace the original KS.

YES

Substitute a known-good ECM and recheck. If symptom/indication goes away, replace the original ECM.

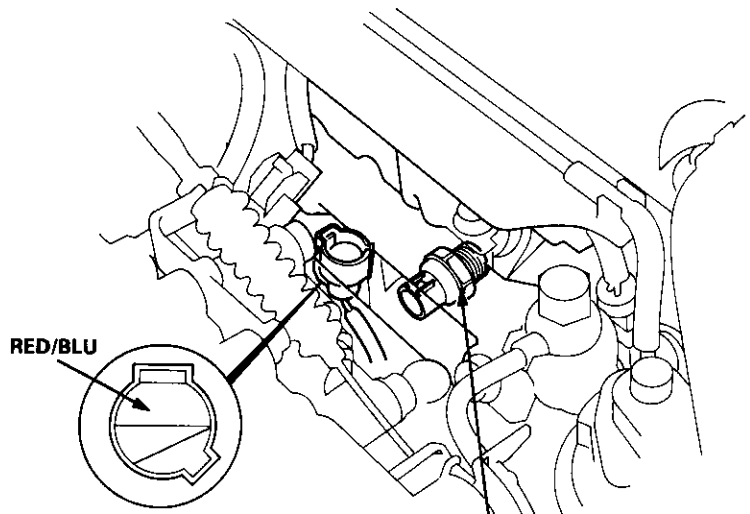

KS
32 N·m (3.2 kg-m, 23 lb-ft)

PGM-FI System

Troubleshooting Flowchart — A/T FI Signal A/B (A/T only)

 The Malfunction Indicator Lamp (MIL) indicates Diagnostic Trouble Code (DTC) 30: A problem in the A/T FI Signal A circuit between Transmission Control Module (TCM) and ECM.

 The Malfunction Indicator Lamp (MIL) indicates Diagnostic Trouble Code (DTC) 31: A problem in the A/T FI Signal B circuit between Transmission Control Module (TCM) and ECM.



With service check connector jumped, (see page 11-42), code 30 and/or 31 are indicated.

Do the ECM Reset Procedure (see page 11-43).

Test drive necessary. Drive the car for several miles so that the transmission upshifts and downshifts several times.

Does the MIL indicate code 30 and/or 31?

NO

Intermittent failure, system is OK at this time. Check for poor connections or loose wires at C411 (TCM) and ECM.

YES

Turn the ignition switch OFF.

Connect the test harness to the main harness only, not to the ECM (see page 11-45).

Disconnect the 22P connector from the TCM.

Check for continuity between B3 and/or B4* terminal and body ground.

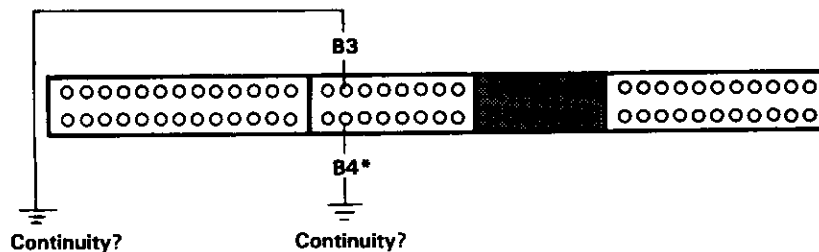

Continuity?

Continuity?

*: code 31 (A/T FI Signal B)

Is there continuity?

YES

Repair short in ORN or PNK* wire between ECM (B3 or B4*) and the TCM.

NO

(To page 11-91)



(From page 11-90)

Check for continuity on ORN or PNK* wire between B3 or B4* and 22P connector of the TCM.

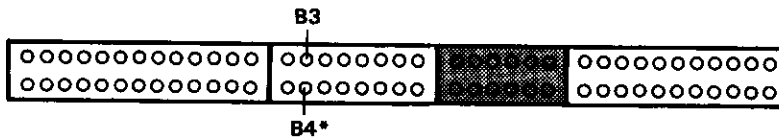

Is there continuity?

NO

Repair open in ORN or PNK* wire between ECM (B3 or B4*) and the TCM.

YES

Substitute a known-good ECM and recheck. If symptom/indication goes away, replace the original ECM.

Idle Control System

System Troubleshooting Guide

NOTE:

- Across each row in the chart, the sub-systems that could be sources of a symptom are ranked in the order they should be inspected, starting with ①. Find the symptom in the left column, read across to the most likely source, then refer to the page listed at the top of that column. If inspection shows the system is OK, try the next system ②, etc.
- If the idle speed is out of specification and the Malfunction Indicator Lamp (MIL) does not blink Diagnostic Trouble Code (DTC) 14, go to inspection described on page 11-95.

PAGE	SUB - SYSTEM	IDLE ADJUSTING SCREW	IDLE AIR CONTROL VALVE	AIR CONDITIONING SIGNAL	ALTERNATOR FR SIGNAL	AUTOMATIC TRANSAXLE GEAR POSITION SWITCH SIGNAL	STARTER SWITCH SIGNAL	BRAKE SWITCH SIGNAL	POWER STEERING PRESSURE SWITCH SIGNAL	FAST IDLE THERMO VALVE	STARTING AIR VALVE	HOSES AND CONNECTIONS
SYMPTOM		111	96	98	100	102	104	106	108	109	110	*
DIFFICULT TO START ENGINE WHEN COLD										①		
WHEN COLD FAST IDLE OUT OF SPEC.(1,000-2,000 rpm)		③	②							①		
ROUGH IDLE			②									①
WHEN WARM RPM TOO HIGH		③	①						③	②		③
WHEN WARM RPM TOO LOW	Idle speed is below specified rpm (no load)	②	①									
	Idle speed does not increase after initial start up.		①									
	On models with automatic transmission, the idle speed drops in gear		②			①						
	Idle speeds drops when air conditioner in ON		②	①								
	Idle speed drops when steering wheel is turning		②						①			
	Idle speed fluctuates with electrical load		②			③						①
FREQUENT STALLING	WHILE WARMING UP	②	①									
	AFTER WARMING UP	①	②									
FAILS EMISSION TEST												①



System Description

The idle speed of the engine is controlled by the Idle Air Control (IAC) Valve. The valve changes the amount of air bypassing into the intake manifold in response to electric current controlled by the ECM. When the IAC Valve is activated, the valve opens to maintain the proper idle speed.

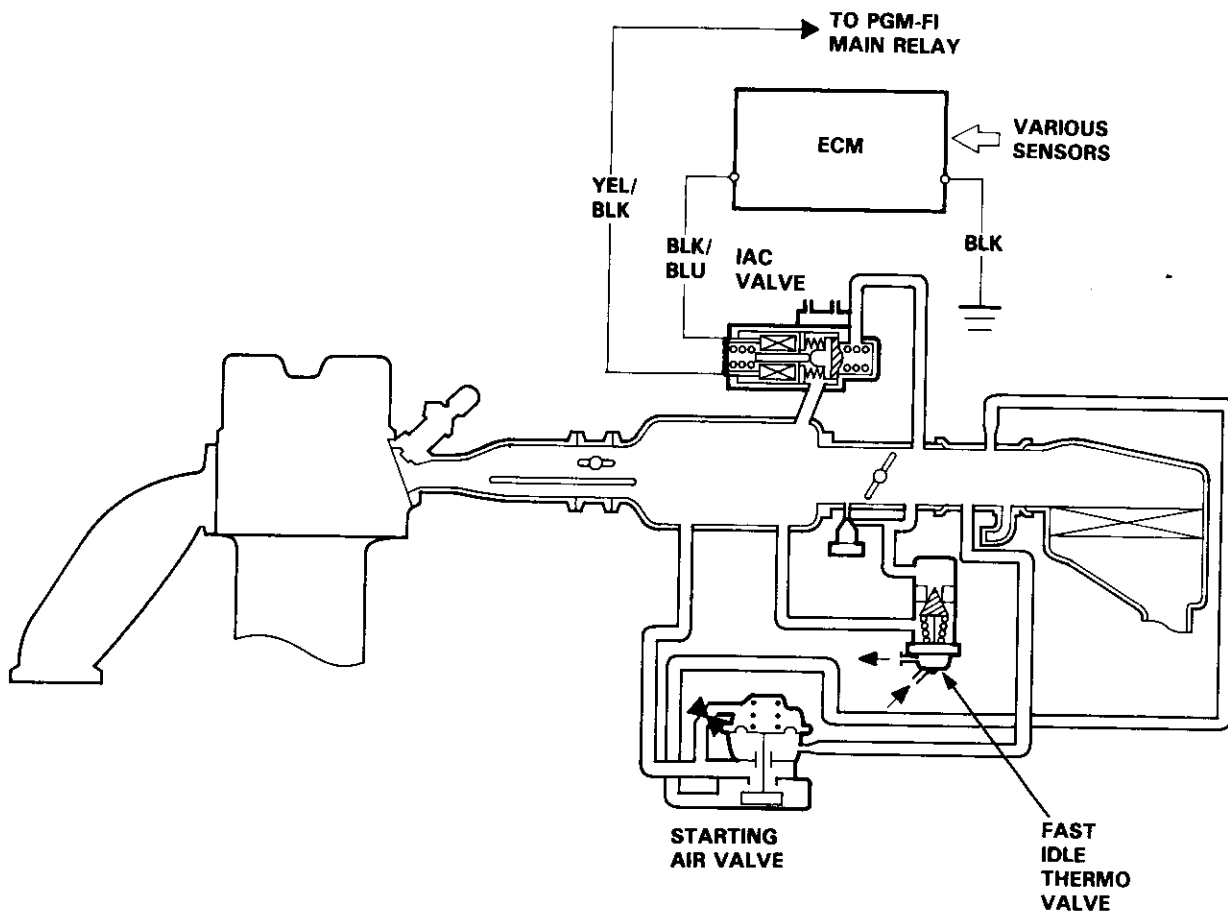

(cont'd)

Idle Control System

System Description (cont'd)

1. After the engine starts, the IAC valve opens for a certain time. The amount of air is increased to raise the idle speed about 150–300 rpm.
2. When the engine coolant temperature is low, the IAC valve is opened to obtain the proper fast idle speed. The amount of bypassed air is thus controlled in relation to the engine coolant temperature.

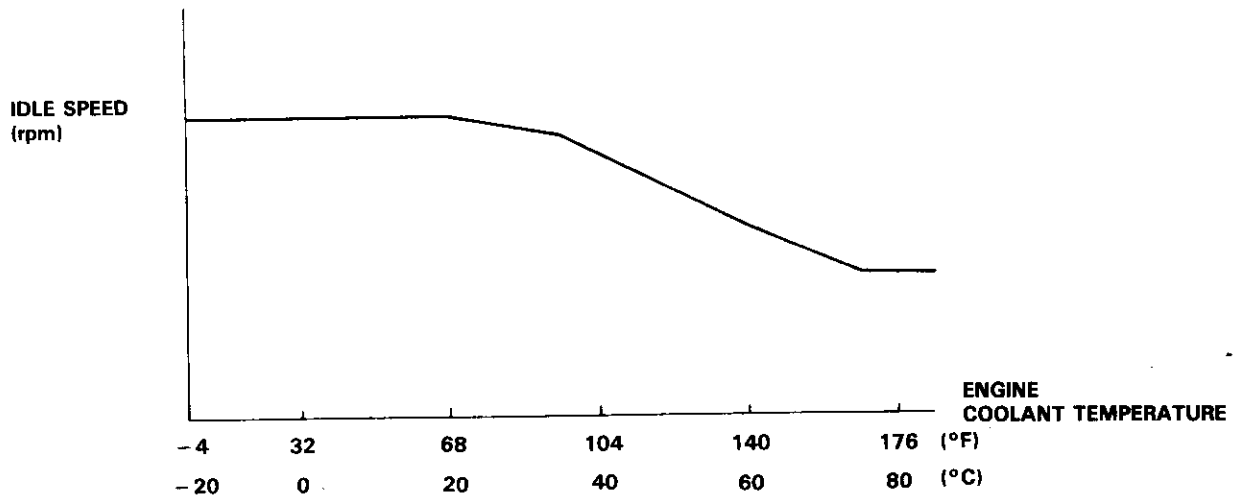



1. When the idle speed is out of specification and the Malfunction Indicator Lamp (MIL) does not blink Diagnostic Trouble Code (DTC) 14, check the following items:
 - Adjust the idle speed (page 11-111)
 - Air conditioning signal (page 11-98)
 - ALT FR signal (page 11-100)
 - A/T gear position signal (page 11-102)
 - Starter switch signal (page 11-104)
 - Brake switch signal (page 11-106)
 - PSP switch signal (page 11-108)
 - Fast idle thermo valve (page 11-109)
 - Starting air valve
 - Hoses and connections
 - IAC valve and its mounting O-rings

2. If the above items are normal, substitute a known-good IAC valve and readjust the idle speed (page 11-111).
 - If the idle speed still cannot be adjusted to specification (and the MIL does not blink code 14) after IAC valve replacement, substitute a known-good ECM and recheck. If symptom goes away, replace the original ECM.

Idle Control System

Troubleshooting Flowchart — Idle Air Control (IAC) Valve

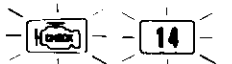

The Malfunction Indicator Lamp (MIL) indicates Diagnostic Trouble Code (DTC) 14: A problem in the Idle Air Control (IAC) Valve circuit.

The IAC Valve changes the amount of air bypassing the throttle body in response to a current signal from the ECM in order to maintain the proper idle speed.

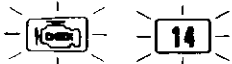
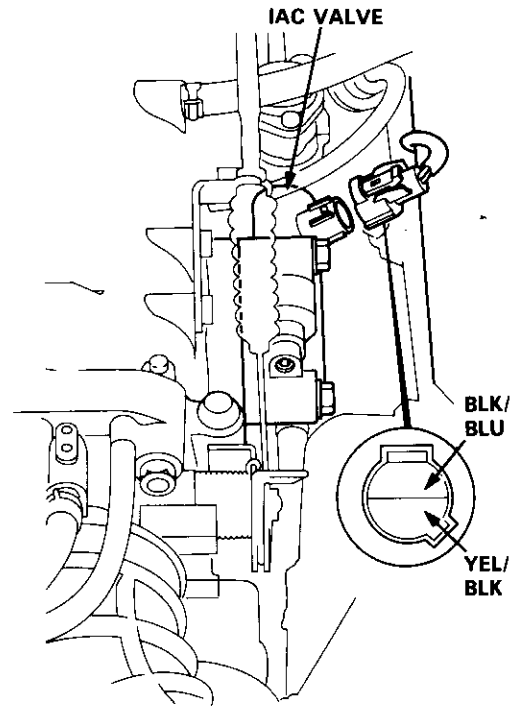
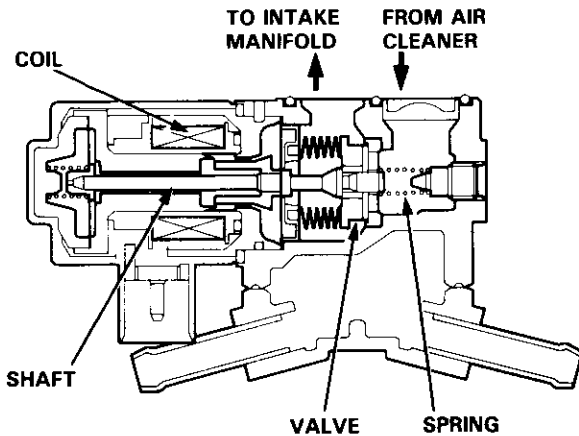

- The MIL has been reported on.
- With service check connector jumped (see page 11-42), code 14 is indicated.

Do the ECM Reset Procedure (see page 11-43).

Start the engine.

Is the MIL on and does it indicate code 14?

NO

With the engine running and the accelerator pedal released, disconnect the 2P connector from the IAC valve.

Is there a reduction in engine rpm?

YES

Intermittent failure, system is OK at this time (test driving may be necessary).
Check for poor connection or loose wires at C425, C433 (located at right shock tower), C106 (IAC valve) and ECM.

NO

Substitute a known-good IAC valve and retest.

Remove the 2P connector from the IAC valve.

YES

(To page 11-97)



(From page 11-96)

Measure voltage between the YEL/BLK wire and body ground.

Is there battery voltage?

NO

Repair open in YEL/BLK wire between the IAC valve and PGM-FI main relay.

YES

Turn the ignition switch off and reconnect the 2P connector to the IAC valve.

Connect the test harness "A" connector to the main wire harness only, not the ECM (see page 11-45).

Turn the ignition switch ON.

Momentarily connect A9 terminal to A26 terminal several times.

Does the IAC valve click?

YES

Substitute a known-good ECM and retest. If symptom/indication goes away, replace the original ECM.

NO

Repair open or short in BLK/BLU wire between IAC valve and ECM (A9). If the wire is OK, replace the IAC valve.

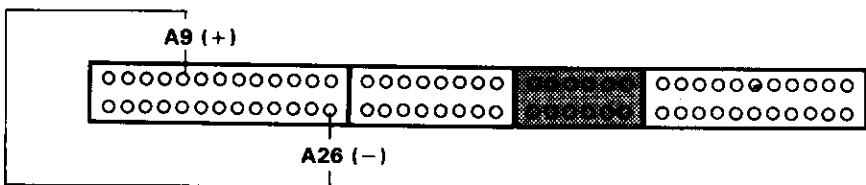

Idle Control System

Troubleshooting Flowchart — Air Conditioning Signal

This signals the ECM when there is a demand for cooling from the air conditioning system.

Inspection of Air Conditioning Signal.

Connect the test harness between the ECM and connectors. Disconnect "B" connector from the main wire harness only, not the ECM (see page 11-45)

Turn the ignition switch ON.

Measure voltage between B5 (+) terminal and A26 (-) terminal.

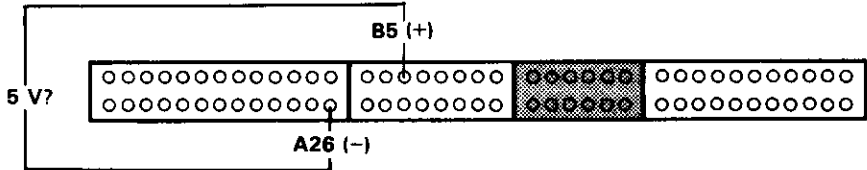

Is there approx. 5 V?

NO
Substitute a known-good ECM and recheck. If prescribed voltage is now available, replace the original ECM.

Reconnect "B" connector to the main wire harness.

Momentarily connect A15 terminal to A26 terminal several times.

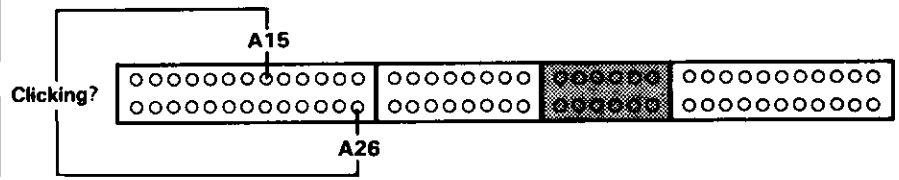

Is there a clicking noise from the A/C compressor clutch?

NO
Connect the RED/BLU terminal of the 4P connector on the A/C clutch relay to body ground.

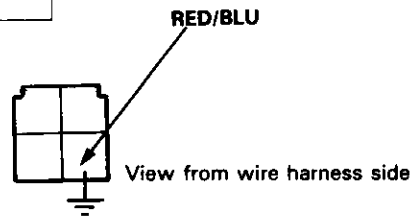

Start the engine.

Blower switch ON.

Is there a clicking noise from the A/C compressor clutch?

NO
See air conditioner inspection (see section 22).

YES
Repair open in RED/BLU wire between ECM (A 15) and A/C clutch relay.

(To page 11-99)

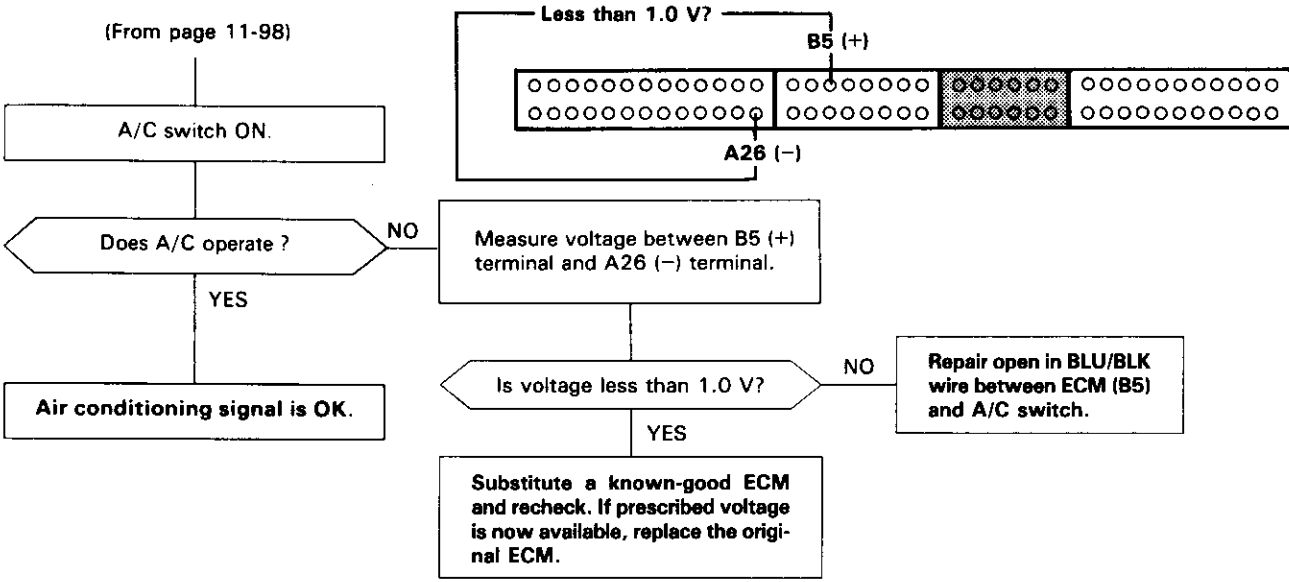

Idle Control System

Troubleshooting Flowchart— Alternator (ALT) FR Signal

This signals the ECM when the alternator is charging.

Inspection of ALT FR signal.

Connect the test harness between the ECM and connectors.
Disconnect "D" connector from the main wire harness only, not the ECM (see page 11-45).

Turn the ignition switch ON.

Measure voltage between D9 (+) terminal and A26 (-) terminal.

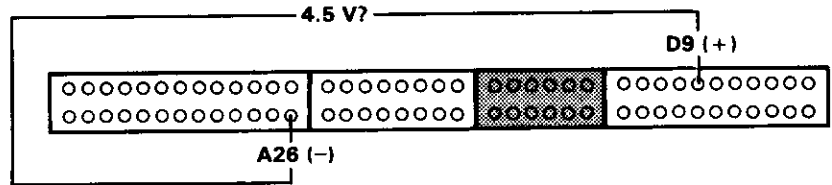

Is there approx. 4.5 V?

NO
Substitute a known-good ECM and recheck. If prescribed voltage is now available, replace the original ECM.

YES

Turn the ignition switch OFF.

Reconnect "D" connector to the main wire harness.

Warm up engine to normal operating temperature (the radiator fan comes on).

Measure voltage between D9 (+) terminal and A26 (-) terminal.

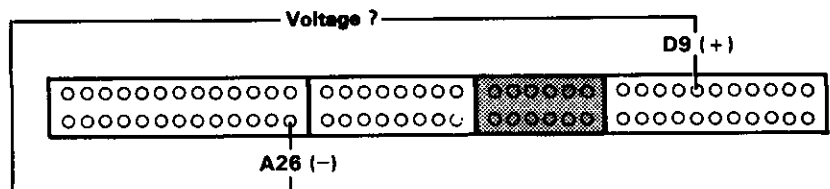

Does the voltage decrease when headlights and rear defogger are turned on?

NO
Turn the ignition switch OFF.

YES

Do the ECM Reset Procedure (see page 11-43).

ALT FR signal is OK.

(To page 11-101)



(From page 11-100)

Disconnect "D" connector from ECM only, not the main wire harness.

Disconnect the negative battery cable from the battery.

Check for continuity between D9 terminal and body ground.

Is there continuity?

YES

Disconnect GRN connector from the alternator.

NO

Disconnect GRN connector from the ALT.

GRN CONNECTOR

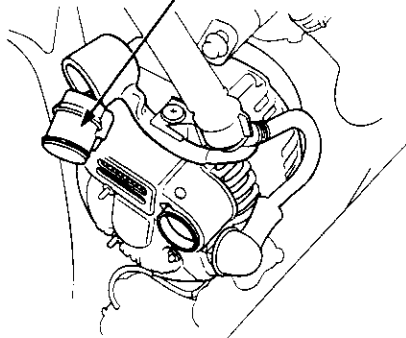

Connect WHT/RED wire to body ground.

Check for continuity between D9 terminal and body ground.

Is there continuity?

YES

NO

Repair open in WHT/RED wire between ECM (D9) and ALT.

See ALT Inspection (section 23).

NOTE: The radio may have a coded theft protection circuit. Be sure you get the customer's code number before disconnecting the battery cable.

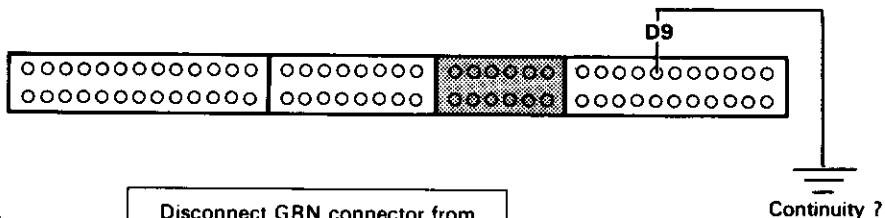

Check for continuity between D9 terminal and body ground.

Is there continuity?

NO

See ALT Inspection (section 23).

YES

Repair short in WHT/RED wire between ECM (D9) and ALT.

Idle Control System

Troubleshooting Flowchart — Automatic Transaxle (A/T) Gear Position Signal (A/T only)

This signals the ECM when the automatic transmission is in **N** or **P** position.

Inspection of A/T Gear Position Signal.

Turn the ignition switch ON.

Observe the A/T gear position indicator and select each position separately.

Does the indicator light properly? **NO** — See A/T gear position indicator inspection (section 14).

YES

Turn the ignition switch OFF.

Connect the test harness between the ECM and connectors. Disconnect "B" connector from the main wire harness only, not the ECM (see page 11-45).

Turn the ignition switch ON.

Measure voltage between B7 (+) terminal and A26 (-) terminal.

Is there approx. 5 V? **NO** — Substitute a known-good ECM and recheck. If prescribed voltage is now available, replace the original ECM.

YES

Turn the ignition switch OFF.

Reconnect "B" connector to the main wire harness.

Start the engine.

(To page 11-103)

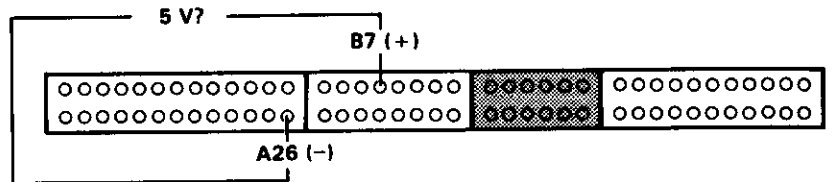



(From page 11-102)

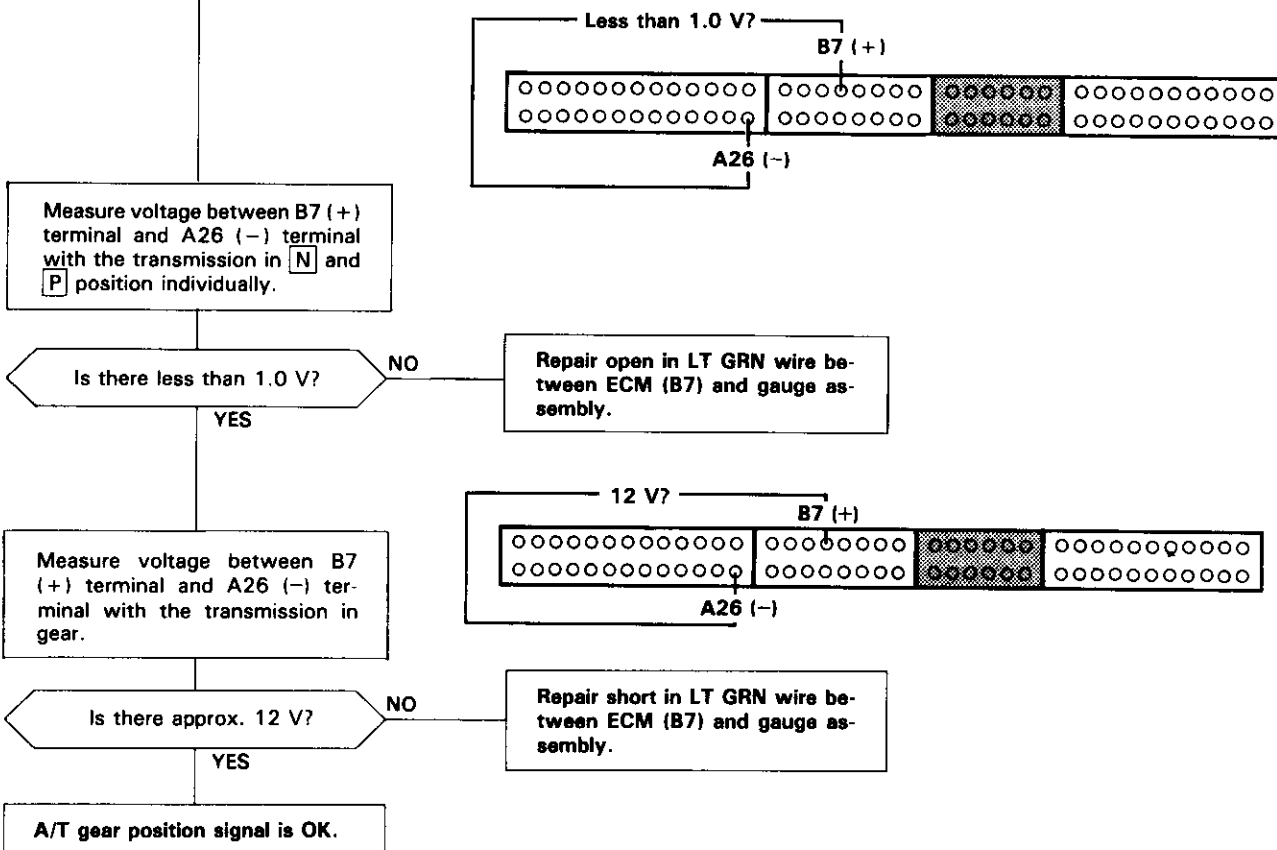

Idle Control System

Troubleshooting Flowchart — Starter Switch Signal

This signals the ECM when the engine is cranking.

Inspection of Starter Switch Signal.

Connect the test harness between the ECM and connectors (see page 11-45)

Measure voltage between B9 (+) terminal and A26 (-) terminal when the ignition switch in the start position.

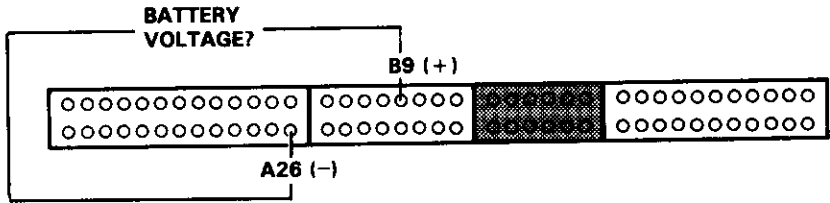

- NOTE:
- M/T: Clutch pedal must be depressed.
 - A/T: Transmission in **N** or **P** position.

Is there battery voltage ?

YES

Starter switch signal is OK.

NO

Inspect No. 2 STARTER SIGNAL (7.5 A) fuse (in the under-dash fuse/relay box).

Is the fuse OK?

YES

Repair open in BLU/RED wire between ECM (B9) and No. 2 STARTER SIGNAL (7.5 A) fuse.

NO

Replace the fuse.

Idle Control System

Troubleshooting Flowchart — Brake Switch Signal

This signals the ECM when the brake pedal is depressed.

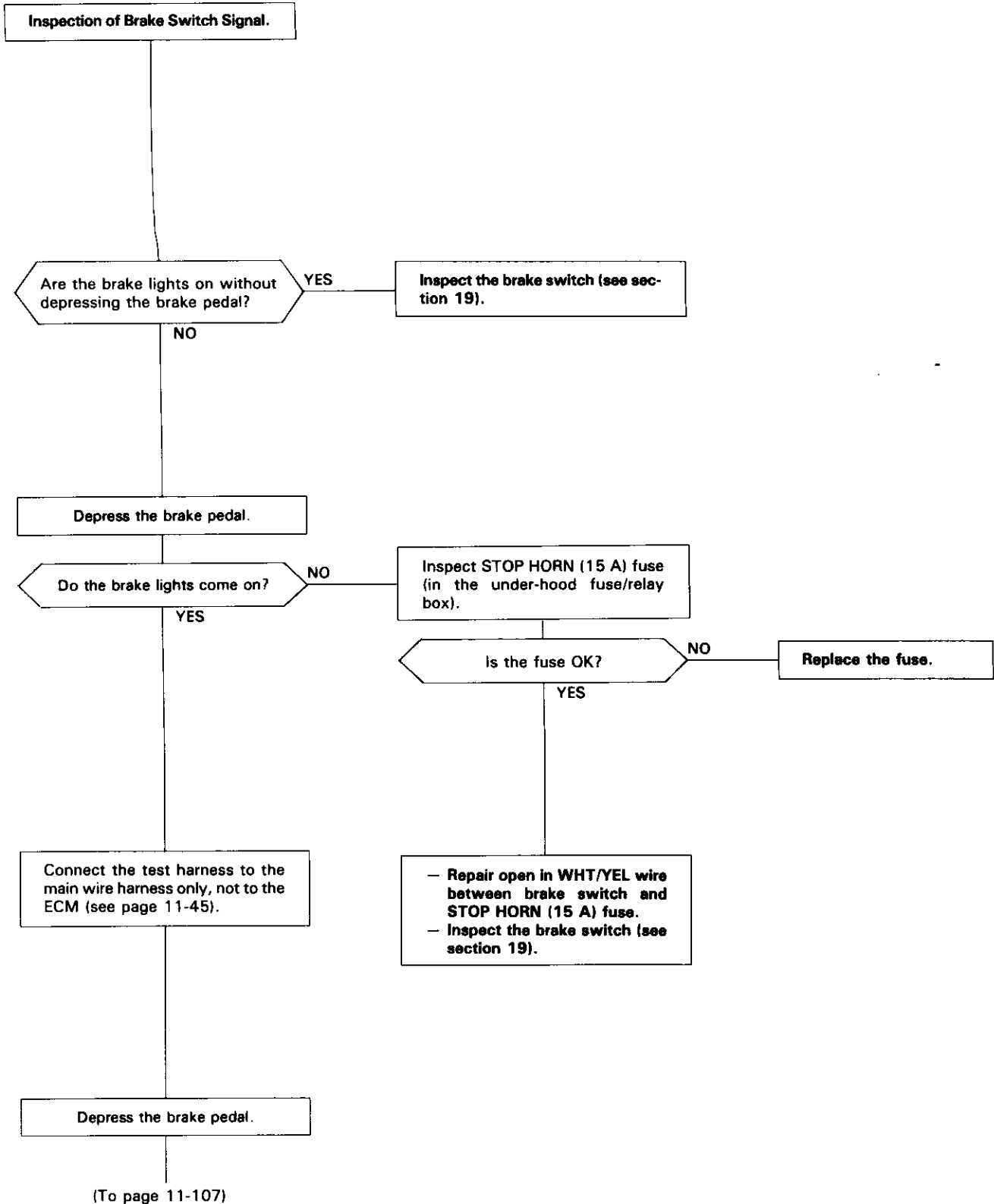



(From page 11-106)

Measure voltage between D2 (+) terminal and A26 (-) terminal with the brake pedal depressed.

Is there battery voltage?

YES
Brake switch signal is OK.

NO
Repair open in GRN/WHT wire between the brake switch and ECM (D2).

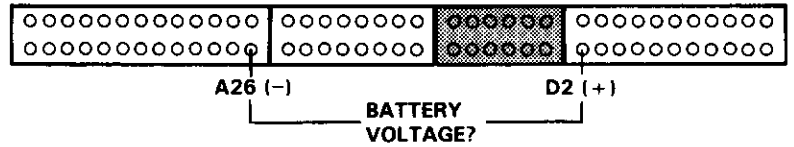

Idle Control System

Troubleshooting Flowchart — Power Steering Pressure (PSP) Switch Signal

This signals the ECM when the power steering load is high.

Inspection of PSP switch Signal

Connect the test harness between the ECM and connectors (see page 11-45).

Turn the ignition switch ON.

Measure voltage between B8 (+) terminal and A26 (-) terminal.

Is there more than 1.0 V?

Start the engine.

Turn steering wheel slowly.

Measure voltage between B8 (+) terminal and A26 (-) terminal while steering wheel is turning.

Is there battery voltage?

PSP switch signal is OK.

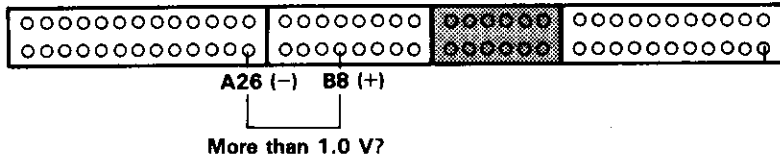

Disconnect the 2P connector from the PSP switch.

Connect RED/GRN terminal to BLK terminal.

Is there more than 1.0 V?

Repair open in RED/GRN wire between ECM (B8) and PSP switch or BLK wire between PSP switch and G101.

Replace the PSP switch.

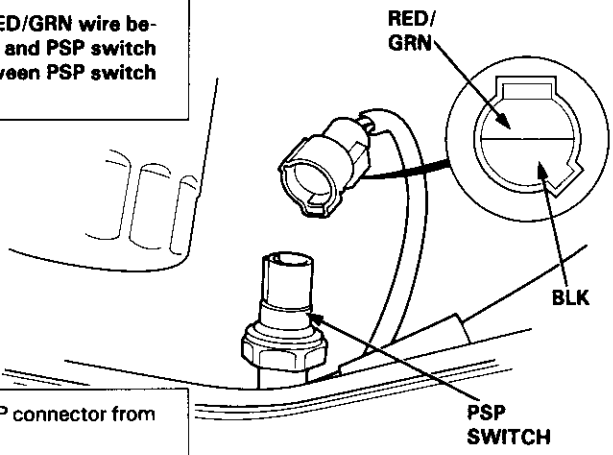

Disconnect the 2P connector from the PSP switch.

Measure voltage between B8 (+) terminal and A26 (-) terminal.

Is there battery voltage?

Repair short in RED/GRN wire between ECM (B8) and PSP switch. If wire is OK, substitute a known-good ECM and recheck. If prescribed voltage is now available, replace the original ECM.

Replace the PSP switch.



Fast Idle Thermo Valve

Description

To prevent erratic running when the engine is warming up, it is necessary to raise the idle speed. The fast idle thermo valve is controlled by a thermowax plunger. When the engine is cold, the engine coolant surrounding the thermowax contracts the plunger, allowing additional air to be bypassed into the intake manifold so that the engine idles faster. When the engine reaches operating temperature, the valve closes, reducing the amount of air bypassing into the manifold.

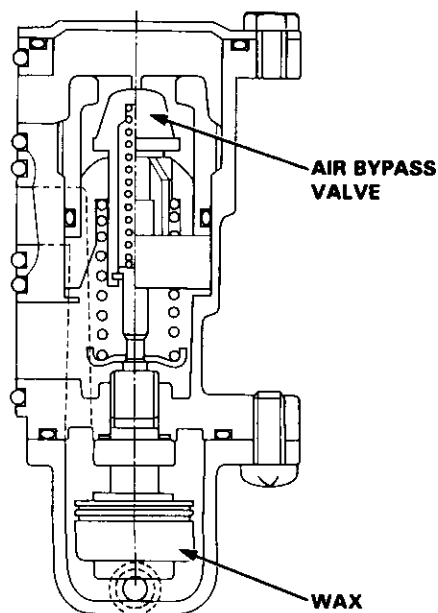
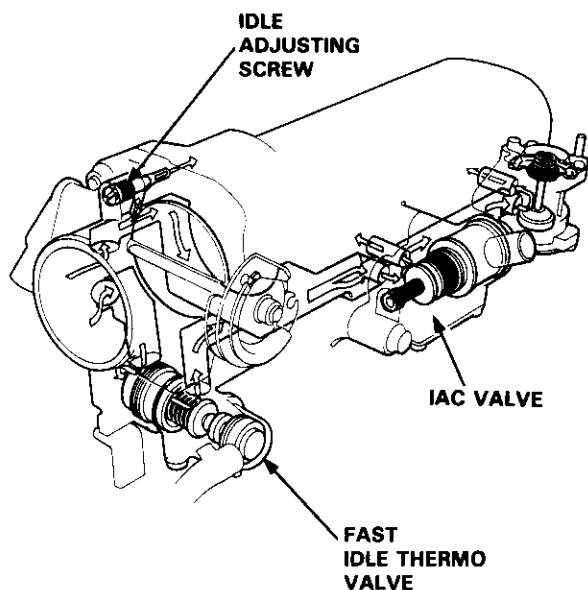

Inspection

H23A1 engine (USA: Si/Canada: SR),
H22A1 engine (USA: Si VTEC/Canada: SR-V)

NOTE: The fast idle thermo valve is factory adjusted; it should not be disassembled.

1. Remove the intake air duct from the throttle body.
2. Start the engine.
3. Put your finger over the lower port in throttle body and make sure that there is air flow with the engine cold (engine coolant temperature below 86°F, 30°C).

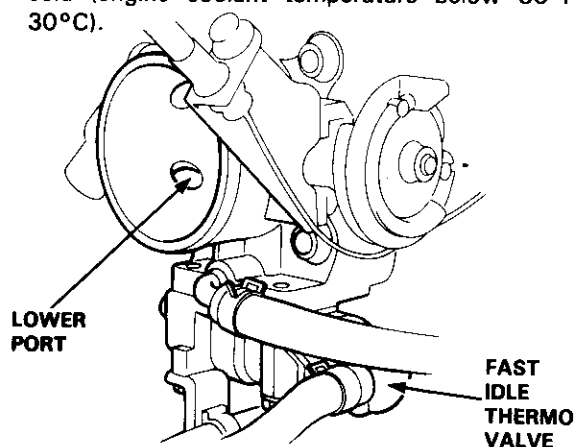

- If not, replace the fast idle thermo valve and retest.

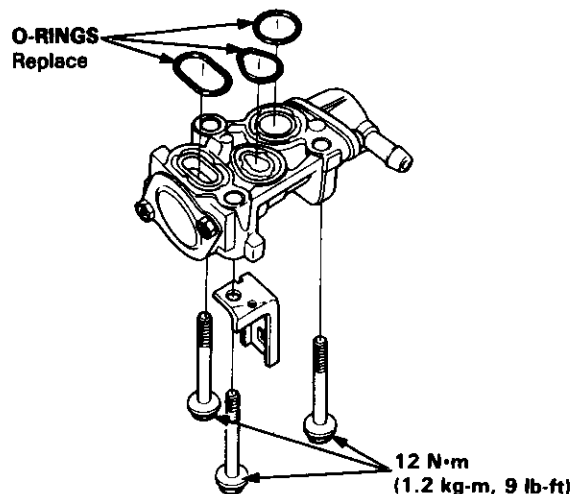

4. Warm up the engine (the radiator fan comes on).
5. Check that the valve is completely closed. If not, air suction can be felt at the lower port in the throttle body.
 - If any suction is felt, the valve is leaking. Check engine coolant level and for air in the engine cooling system (see section 10). If OK, replace the fast idle thermo valve and recheck.

(cont'd)

Idle Control System

Fast Idle Thermo Valve (cont'd)

F22A1 engine (S):

NOTE: The fast idle thermo valve is factory adjusted; it should not be disassembled.

1. Remove the cover of the fast idle thermo valve.
2. Start the engine.
3. Put your finger on the valve seat area and make sure that there is air flow with the engine cold (engine coolant temperature below 86°F, 30°C) and idling.

FAST IDLE THERMO VALVE

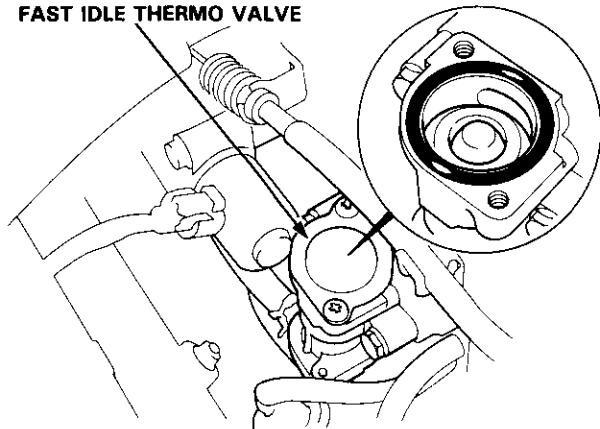

- If not, replace the fast idle thermo valve and retest.

12 N·m
(1.2 kg·m, 9 lb·ft)

O-RINGS
Replace

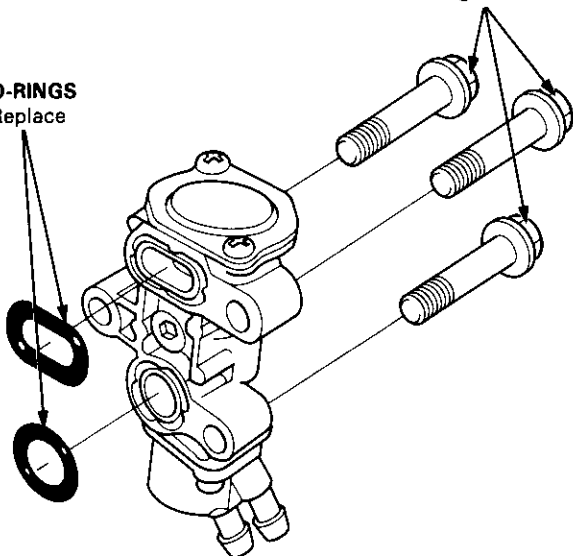

4. Warm up the engine (the radiator fan comes on).
5. Check that the valve is completely closed. If not, air suction can be felt in the valve seat area.
 - If any suction is felt, the valve is leaking. Check engine coolant level and for air in the engine cooling system (see section 10). If OK, replace the fast idle thermo valve and recheck.

Starting Air Valve

Description

When cranking the engine, the starting air valve supplies additional air to the intake manifold to ease engine starting.

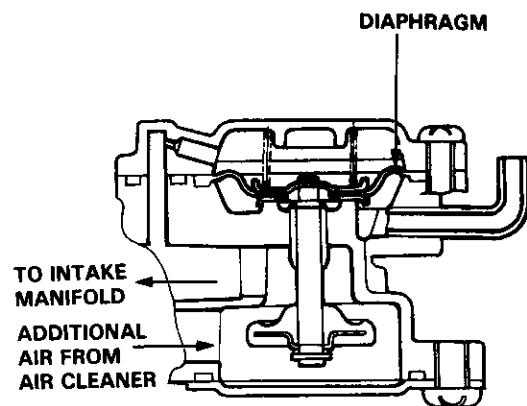



Idle Speed Setting

Inspection/Adjustment

NOTE: (Canada) Pull the parking brake lever up. Start the engine, then check that the headlights are off.

1. Start the engine and warm it up to normal operating temperature (the radiator fan comes on).
2. Turn the ignition switch OFF.
3. Connect a tachometer.
4. Disconnect the 2P connector from the Idle Air Control (IAC) valve.

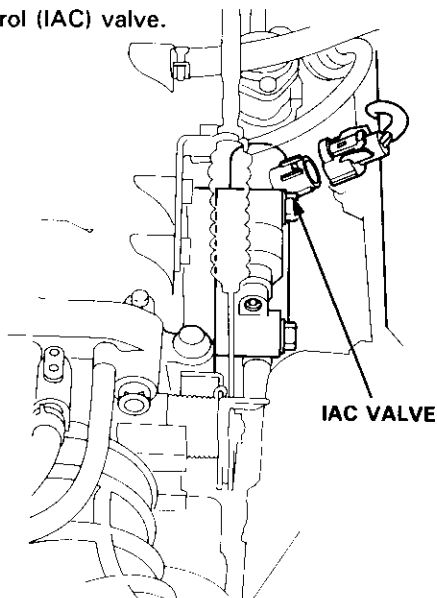

5. Start the engine with the accelerator pedal slightly depressed. Stabilize the rpm at 1000, then slowly release the pedal until the engine idles.
6. Check idling in no-load conditions: headlights, blower fan, rear defogger, radiator fan, and air conditioner are not operating.

Idle speed should be;

H23A1 engine (USA: Si/Canada: SR):

M/T	550 ± 50 rpm
A/T	550 ± 50 rpm (in N or P position)

H22A1 engine (USA: Si VTEC/Canada: SR-V):

550 ± 50 rpm

F22A1 engine (S):

M/T	550 ± 50 rpm
A/T	550 ± 50 rpm (in N or P position)

Adjust the idle speed, if necessary, by turning the idle adjusting screw.

IDLE ADJUSTING SCREW

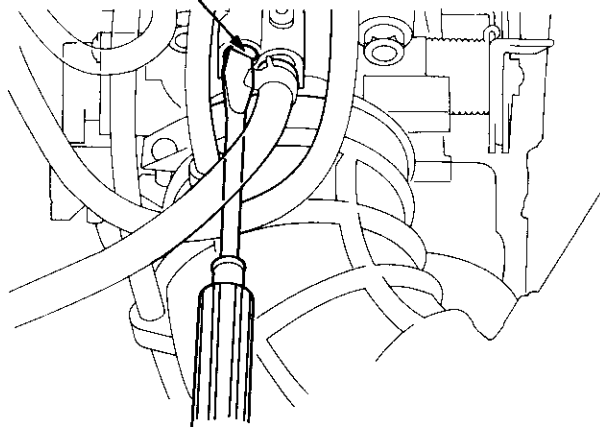

7. Turn the ignition switch OFF.
8. Reconnect the 2P connector on the IAC valve, then remove CLOCK RADIO (10 A) fuse in the under-hood fuse/relay box for 10 seconds to reset the ECM.
9. Restart and idle the engine with no-load conditions for one minute, then check the idle speed.

NOTE: (Canada) Pull the parking brake lever up. Start the engine, the check that the headlights are off.

Idle speed should be;

H23A1 engine (USA: Si/Canada: SR):

M/T	700 ± 50 rpm
A/T	700 ± 50 rpm (in N or P position)

H22A1 engine (USA: Si VTEC/Canada: SR-V):

700 ± 50 rpm

F22A1 engine (S):

M/T	700 ± 50 rpm
A/T	700 ± 50 rpm (in N or P position)

(cont'd)

Idle Control System

Idle Speed Setting (cont'd)

10. Idle the engine for one minute with headlights (Hi) and rear defogger ON and check the idle speed.

Idle speed should be:

H23A1 engine (USA: Si/Canada: SR):

M/T	780 ± 50 rpm
A/T	780 ± 50 rpm (in N or P position)

H22A1 engine (USA: Si VTEC/Canada: SR-V):

790 ± 50 rpm

F22A1 engine (S):

M/T	770 ± 50 rpm
A/T	770 ± 50 rpm (in N or P position)

11. Turn the headlights and rear defogger off. Idle the engine for one minute with heater fan switch at HI and air conditioner on, then check the idle speed.

Idle speed should be:

H23A1 engine (USA: Si/Canada: SR):

M/T	780 ± 50 rpm
A/T	780 ± 50 rpm (in N or P position)

H22A1 engine (USA: Si VTEC/Canada: SR-V):

790 ± 50 rpm

F22A1 engine (S):

M/T	770 ± 50 rpm
A/T	770 ± 50 rpm (in N or P position)

NOTE: If the idle speed is not within specification, see System Troubleshooting Guide on page 11-92.

Fuel Supply System

System Troubleshooting Guide



NOTE: Across each row in the chart, the sub-systems that could be sources of a symptom are ranked in the order they should be inspected starting with ①. Find the symptom in the left column, read across to the most likely source, then refer to the page listed at the top of that column. If inspection shows the system is OK, try the next most likely system ②, etc.

PAGE	SUB-SYSTEM	FUEL INJECTOR	FUEL PRESSURE REGULATOR	FUEL FILTER	FUEL PUMP	PGM-FI MAIN RELAY	CONTAMINATED FUEL
	SYMPTOM	116	122	123	124	126	*
	ENGINE WON'T START			③	①	②	
	DIFFICULT TO START ENGINE WHEN COLD OR HOT			①			
	ROUGH IDLE	①					②
POOR PERFORMANCE	MISFIRE OR ROUGH RUNNING	①	③				②
	FAILS EMISSION TEST	②	①				
	LOSS OF POWER	③		①	③		②
FREQUENT STALLING	WHILE WARMING UP		①				
	AFTER WARMING UP		①				

* Fuel with dirt, water or a high percentage of alcohol is considered contaminated.

Fuel Supply System

System Description

The fuel supply system consists of a fuel tank, in-tank high pressure fuel pump, PGM-FI main relay, fuel filter, fuel pressure regulator, fuel injectors, injector resistor, and fuel delivery and return pipes and hoses. This system delivers pressure-regulated fuel to the fuel injectors and cuts the fuel delivery when the engine is not running.

Fuel Pressure

Relieving

⚠ WARNING

- Do not smoke while working on the fuel system. Keep open flames or sparks away from your work area.
- Be sure to relieve fuel pressure while the engine is off.

NOTE: Before disconnecting fuel pipes or hoses, release pressure from the system by loosening the 6 mm service bolt on top of the fuel rail.

1. Disconnect the battery negative cable from the battery negative terminal.

NOTE: The radio may have a coded theft protection circuit. Be sure you get the customer's code number before disconnecting the battery cable.

2. Remove the fuel fill cap.
3. Use a box end wrench on the 6 mm service bolt at the fuel rail, while holding the special banjo bolt with another wrench.
4. Place a rag or shop towel over the 6 mm service bolt.
5. Slowly loosen the 6 mm service bolt one complete turn.

SERVICE BOLT
12 N·m (1.2 kg·m, 9 lb-ft)

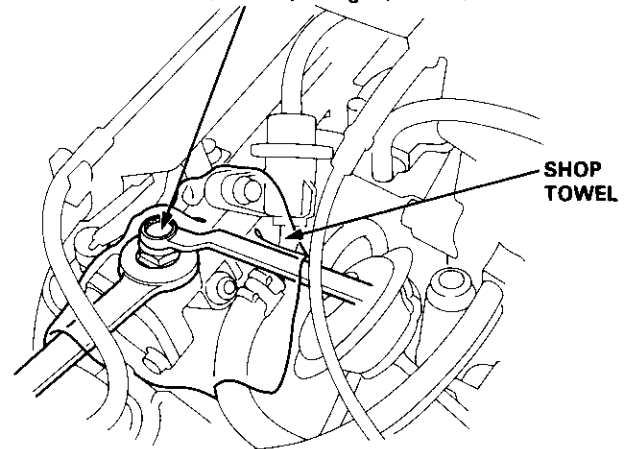

NOTE:

- A fuel pressure gauge can be attached at the 6 mm service bolt hole.
- Always replace the washer between the service bolt and the special banjo bolt, whenever the service bolt is loosened.
- Replace all washers whenever the bolts are removed.



Inspection

1. Relieve fuel pressure (see page 11-114).
2. Remove the service bolt on the fuel rail while holding the banjo bolt with another wrench. Attach the fuel pressure gauge.
3. Start the engine. *Measure the fuel pressure with the engine idling and vacuum hose of the fuel pressure regulator disconnected from the fuel pressure regulator and pinched.

Pressure should be:

H23A1 engine (USA: Si/Canada: SR),

F22A1 engine (S):

255–305 kPa (2.55–3.05 kg/cm², 36–43 psi)

H22A1 engine (USA: Si VTEC/Canada: SR-V):

230–280 kPa (2.3–2.8 kg/cm², 33–40 psi)

4. Reconnect vacuum hose to the fuel pressure regulator.

Pressure should be:

H23A1 engine (USA: Si/Canada: SR),

F22A1 engine (S):

195–245 kPa (1.95–2.45 kg/cm², 28–35 psi)

H22A1 engine (USA: Si VTEC/Canada: SR-V):

170–220 kPa (1.7–2.2 kg/cm², 24–31 psi)

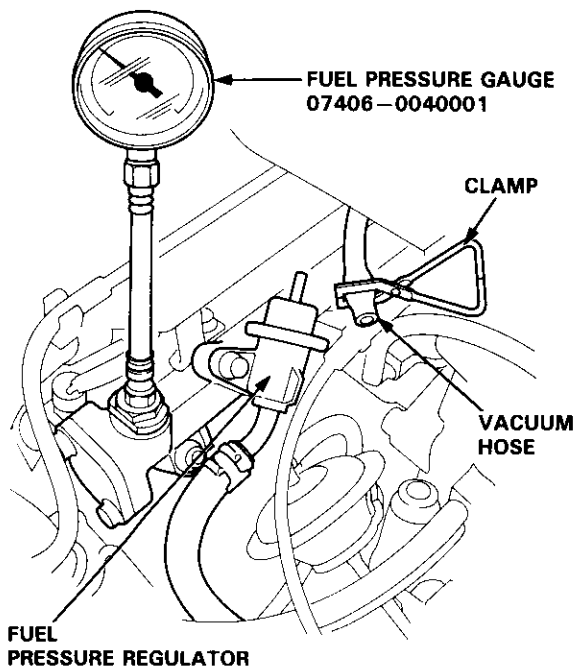

*: If the engine will not start, turn the ignition switch on, wait for two seconds, turn it off then back on again and read the fuel pressure.

- If the fuel pressure is not as specified, first check the fuel pump (see page 11-125). If the pump is OK, check the following:

- If the fuel pressure is higher than specified, inspect for:
 - Pinched or clogged fuel return hose or pipe.
 - Faulty fuel pressure regulator (see page 11-122).
- If the fuel pressure is lower than specified inspect, for:
 - Clogged fuel filter.
 - Faulty fuel pressure regulator (see page 11-122).
 - Leakage in the fuel pipes or hoses.

Fuel Supply System

Fuel Injectors

Troubleshooting Flowchart

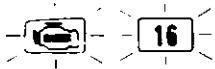

The Malfunction Indicator Lamp (MIL) indicates Diagnostic Trouble Code (DTC) 16: A problem in the Fuel Injector circuit.

The Fuel Injectors are a solenoid-actuated constant-stroke pintle type consisting of a solenoid, plunger needle valve and housing. When current is applied to the solenoid coil, the valve lifts up and pressurized fuel is injected. Because the needle valve lift and the fuel pressure are constant, the injection quantity is determined by the length of time that the valve is open (i.e., the duration the current is supplied to the solenoid coil). The Fuel Injector is sealed by an O-ring and seal ring at the top and bottom. These seals also reduce operating noise.

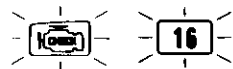
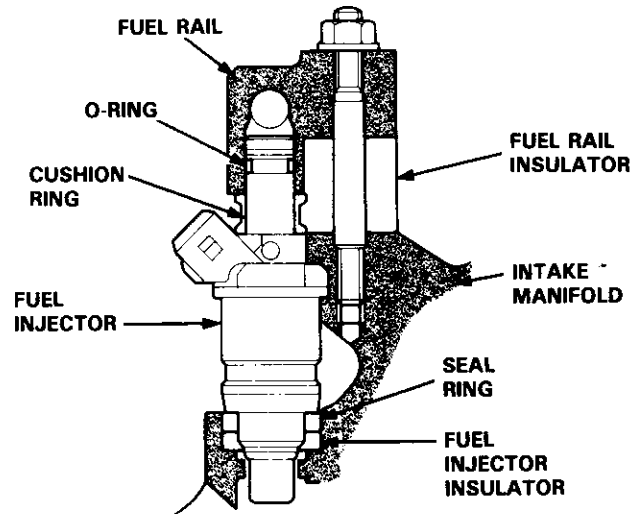
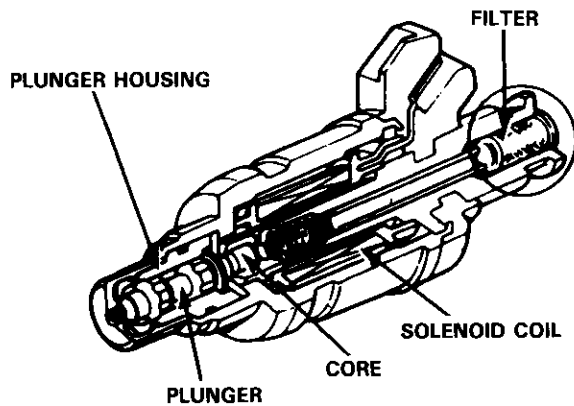

- The MIL has been reported on.
- With service check connector jumped (see page 11-42), code 16 is indicated.

Do the ECM Reset Procedure (see page 11-43).

Start the engine and allow it to idle.

Is the MIL on and does it indicate code 16?

YES

NO

NOTE: If engine will not start, it may take 10 seconds of cranking to set the code.

Intermittent failure, system is OK at this time (test drive may be necessary).
Check for poor connections or loose wires at C433, C425 (located at right shock tower), C102, C103, C104, C105 (fuel injectors), C107 (injector resistor), and ECM.

(To page 11-117)



(From page 11-116)

Start engine and listen at each fuel injector for a clicking sound.

Turn the ignition switch OFF.

Disconnect the 2P connector from the fuel injector that does not click.

Measure resistance between the 2 terminals of fuel injector.

Is there 1.5–2.5 Ω ?

NO

Replace the fuel injector/injectors that are not 1.5–2.5 Ω .

YES

Turn the ignition switch ON.

Measure voltage between RED/BLK (+) terminal in the 2P connector and body ground.

Is there battery voltage?

NO

Turn the ignition switch OFF.

YES

Disconnect 6P connector from the injector resistor.

Turn the ignition switch ON.

Measure voltage between YEL/BLK (+) terminal and body ground.

(To page 11-118)

(To page 11-118)

(cont'd)

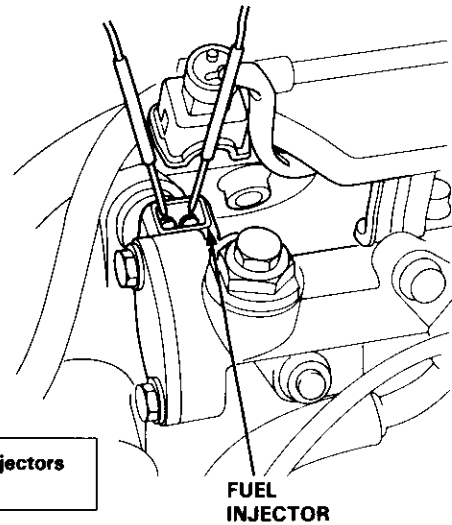
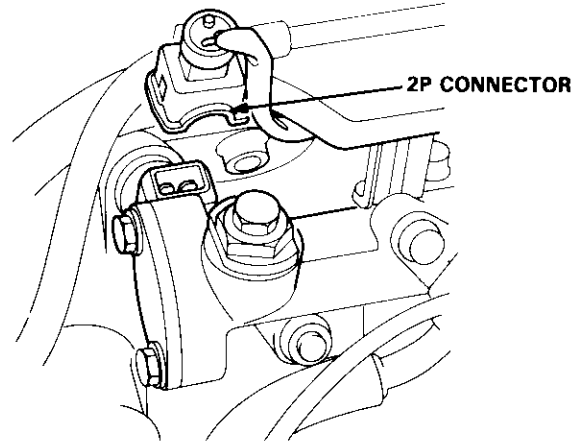

Fuel Supply System

Fuel Injectors (cont'd)

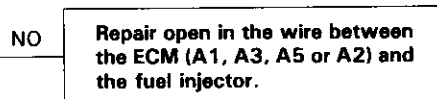
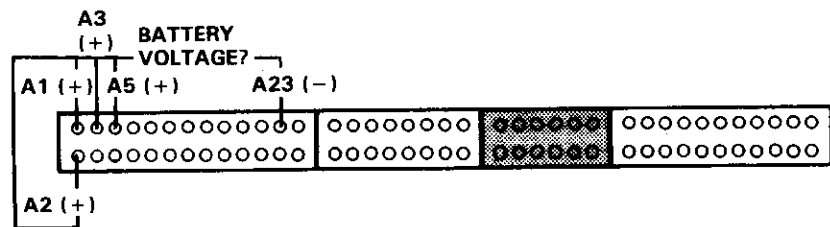
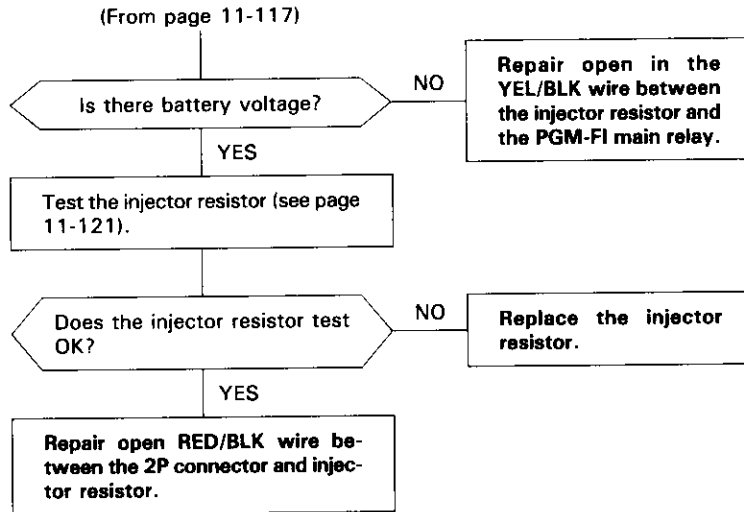
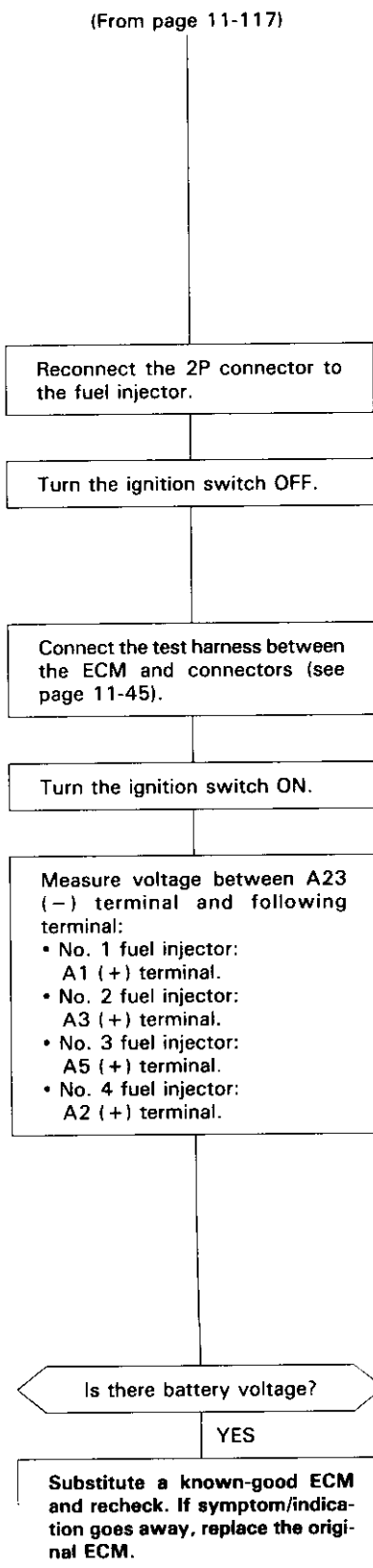



Replacement

⚠ WARNING Do not smoke when working on the fuel system. Keep open flames away from your work area.

1. Relieve fuel pressure (see page 11-114).
2. Disconnect the connectors from the fuel injectors and IAC valve.
3. Disconnect the vacuum hose from the fuel pressure regulator and EGR valve, and the fuel return hose from the fuel pressure regulator.

NOTE: Place a rag or shop towel over the hoses before disconnecting them.

4. Disconnect the fuel hose from the fuel rail.
5. Loosen the retainer nuts on the fuel rail and harness holder.
6. Disconnect the PCV valve and fuel rail.
7. Remove the fuel injectors from the intake manifold.

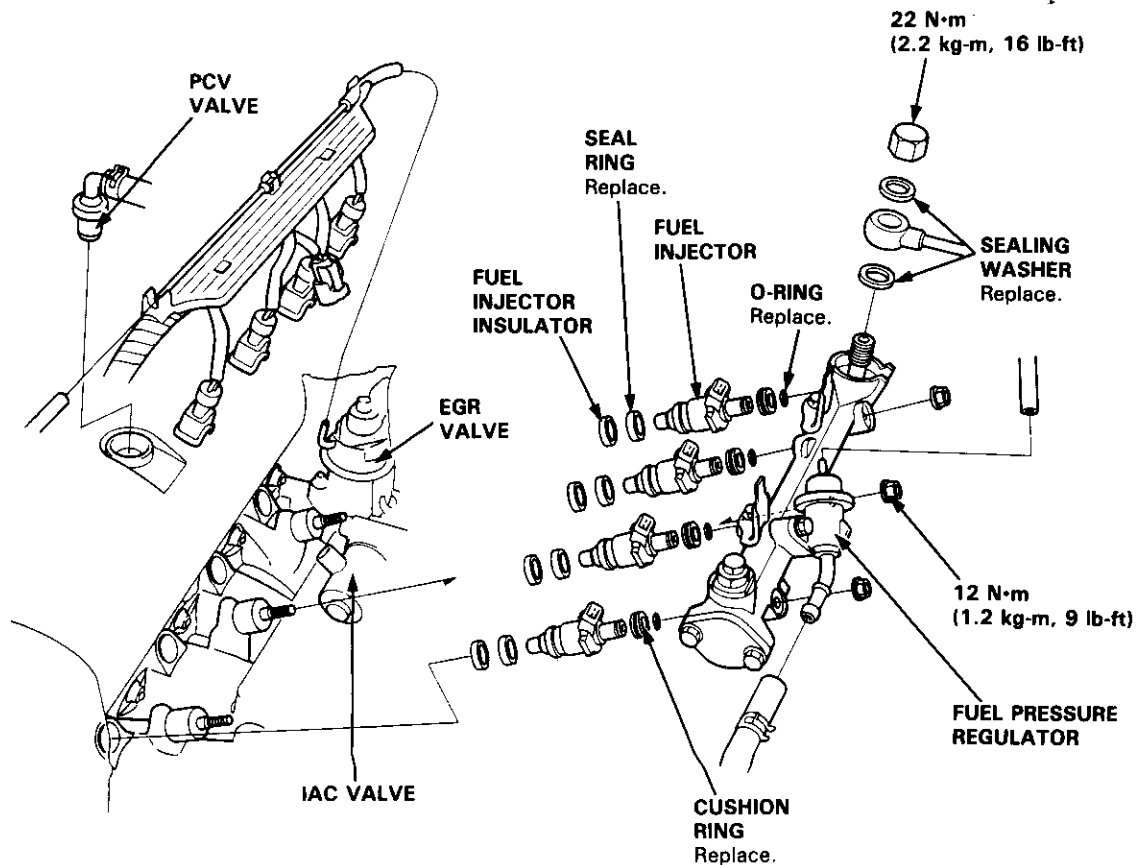

8. Slide new cushion rings onto the fuel injectors.
9. Coat new O-rings with clean engine oil and put them on the fuel injectors.
10. Insert the fuel injectors into the fuel rail first.
11. Coat new seal rings with clean engine oil and press them into the intake manifold.

(cont'd)

Fuel Supply System

Fuel Injectors (cont'd)

12. Install the fuel injectors and fuel rail assembly in the manifold.

CAUTION:

- To prevent damage to the O-rings, install the fuel injectors in the fuel rail first, then install them in the intake manifold.

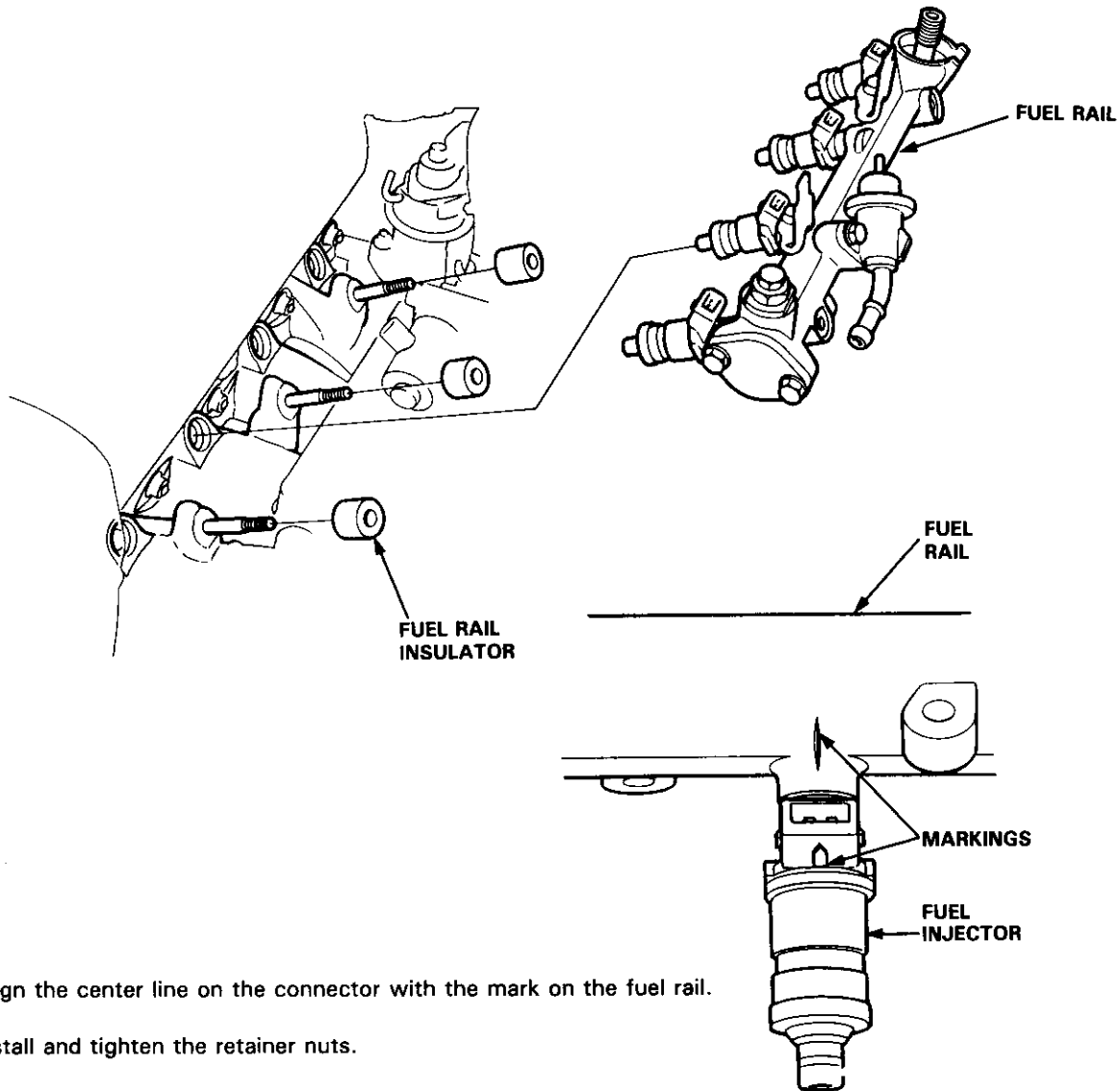

13. Align the center line on the connector with the mark on the fuel rail.

14. Install and tighten the retainer nuts.

15. Connect the fuel hose to the fuel rail with new washers.

16. Connect the vacuum hose to the fuel pressure regulator and EGR valve, and the fuel return hose to the fuel pressure regulator.

17. Install the connectors on the fuel injectors and IAC valve.

18. Replace the 6 mm service bolt washer and tighten the bolt.

19. Turn the ignition switch ON, but do not operate the starter. After the fuel pump runs for approximately two seconds, the fuel pressure in the fuel line rises. Repeat this two or three times, then check whether there is any fuel leakage.



Injector Resistor

Description

The resistor lowers the current supplied to the fuel injectors to prevent damage to the fuel injector coils. This allows a faster response time of the fuel injectors.

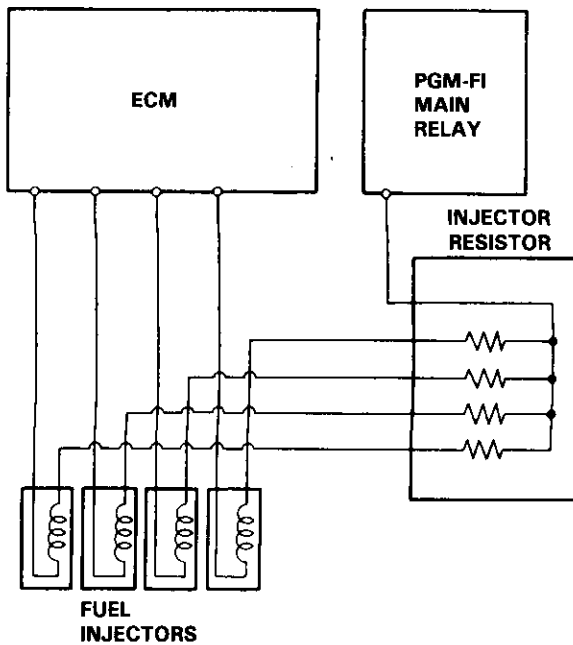

Testing

1. Disconnect the injector resistor connector.
2. Check for resistance between each of the injector resistor terminals (E, D, C and B) and the power terminal (A).

Resistance should be: 5–7 Ω

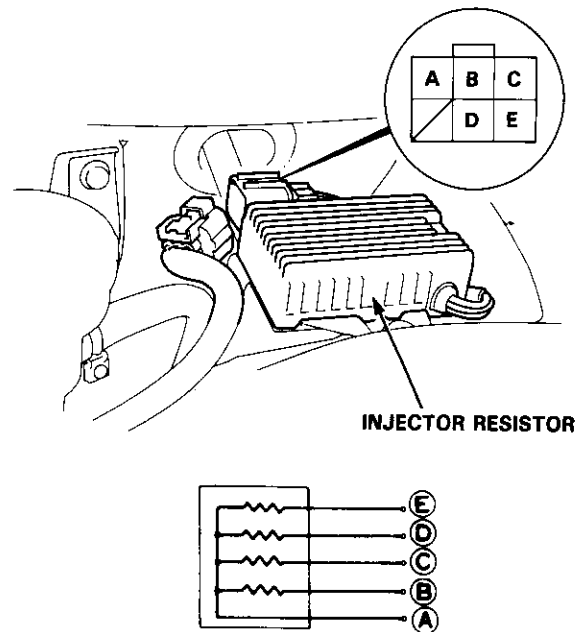

- Replace the injector resistor with a new one if any of the resistances are outside of the specification.

Fuel Supply System

Fuel Pressure Regulator

Description

The fuel pressure regulator maintains a constant fuel pressure to the fuel injectors. When the difference between the fuel pressure and manifold pressure exceeds 300 kPa (3.0 kg/cm², 43 psi), the diaphragm is pushed upward, and the excess fuel is fed back into the fuel tank through the return line.

CLOSE

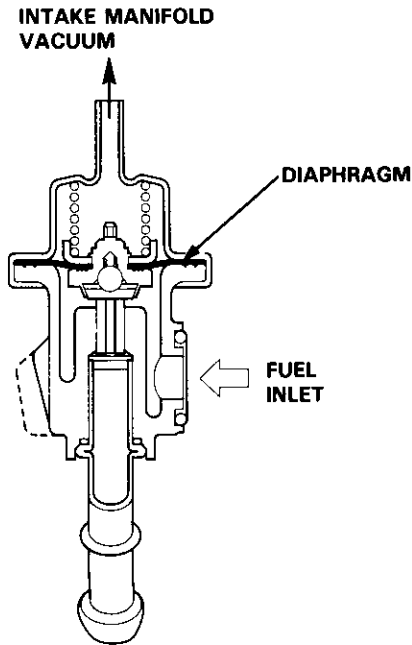

OPEN

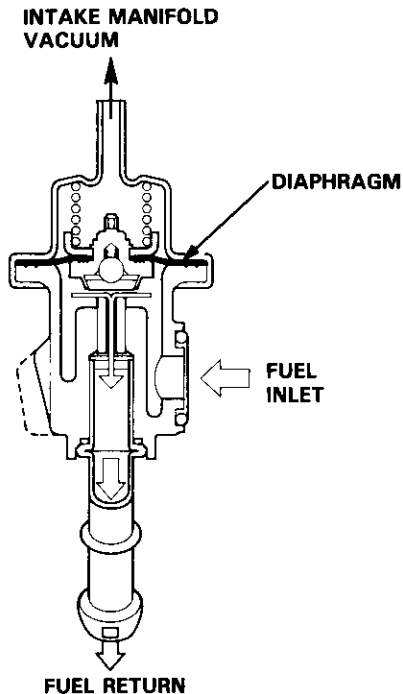

Testing

▲ WARNING

Do not smoke during the test. Keep open flames away from your work area.

1. Attach a fuel pressure gauge to the service port of the fuel rail (see page 11-115).

Pressure should be:

H23A1 engine (USA: Si/Canada: SR),

F22A1 engine (S):

255–305 kPa (2.55–3.05 kg/cm², 36–43 psi)

H22A1 engine (USA: Si VTEC/Canada: SR-V):

230–280 kPa (2.3–2.8 kg/cm², 33–40 psi)

(with the fuel pressure regulator vacuum hose disconnected and pinched)

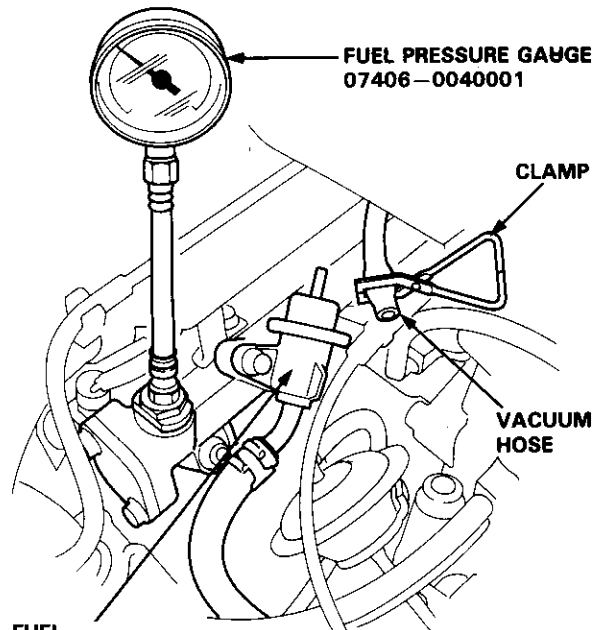

FUEL PRESSURE REGULATOR

2. Reconnect the vacuum hose to the fuel pressure regulator.
3. Check that the fuel pressure rises when the vacuum hose from the fuel pressure regulator is disconnected again.

If the fuel pressure did not rise, replace the fuel pressure regulator.



Replacement

⚠ WARNING Do not smoke while working on fuel system. Keep open flame away from your work area.

1. Place a shop towel under the fuel pressure regulator, then relieve fuel pressure (see page 11-114).
2. Disconnect the vacuum hose and fuel return hose.
3. Remove the two 6 mm mounting bolts.

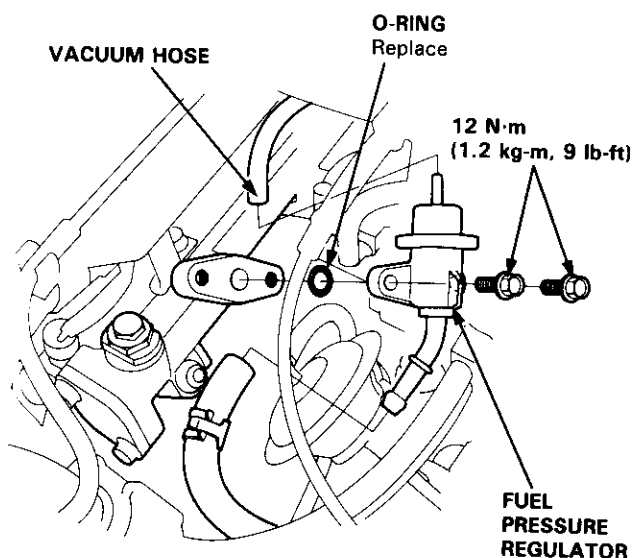

NOTE:

- Replace the O-ring.
- When assembling the fuel pressure regulator, apply clean engine oil to the O-ring and assemble it into its proper position, taking care not to damage the O-ring.

Fuel Filter

Replacement

⚠ WARNING Do not smoke while working on fuel system. Keep open flame away from your work area.

The fuel filter should be replaced every 4 years or 60,000 miles (96,000 km), whichever comes first or whenever the fuel pressure drops below the specified value [H23A1 engine, F22A1 engine: 255–305 kPa, 2.55–3.05 kg/cm², 36–43 psi (H22A1 engine: 230–280 kPa, 2.3–2.8 kg/cm², 33–40 psi) with the fuel pressure regulator vacuum hose disconnected and pinched] after making sure that the fuel pump and the fuel pressure regulator are OK.

1. Place a shop towel under and around the fuel rail.
2. Relieve fuel pressure (see page 11-114).
3. Remove the 12 mm banjo bolt and the fuel feed pipe from the fuel filter.
4. Remove the fuel filter clamp and fuel filter.
5. When assembling, use new washers, as shown.

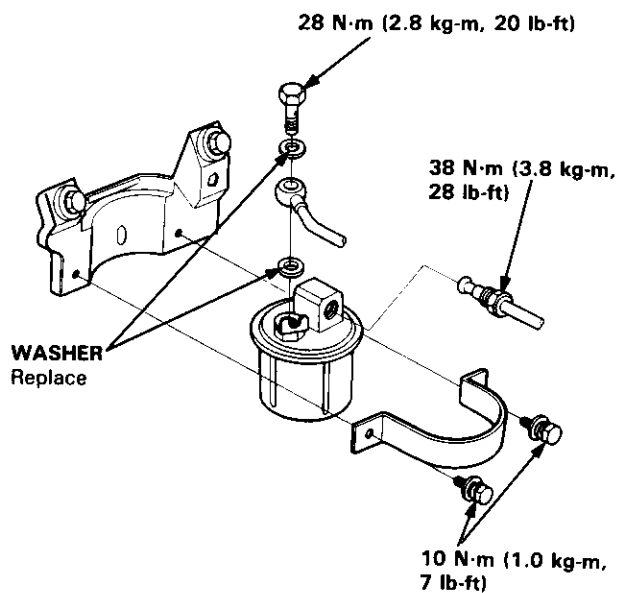

NOTE: Clean the flared joint of high pressure hoses thoroughly before reconnecting them.

Fuel Supply System

Fuel Pump

Description

Because of its compact impeller design, the fuel pump is installed inside the fuel tank, thereby saving space and simplifying the fuel line system.

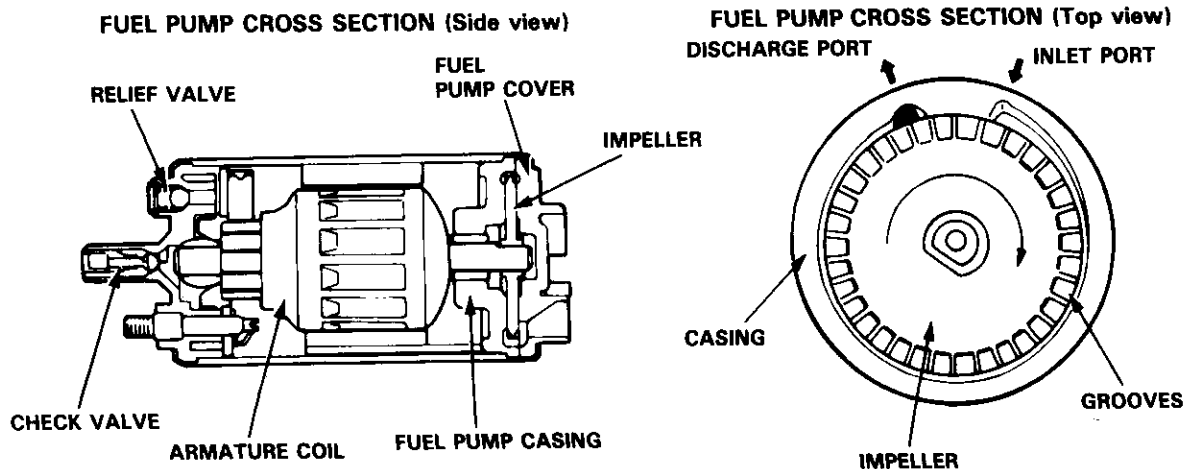
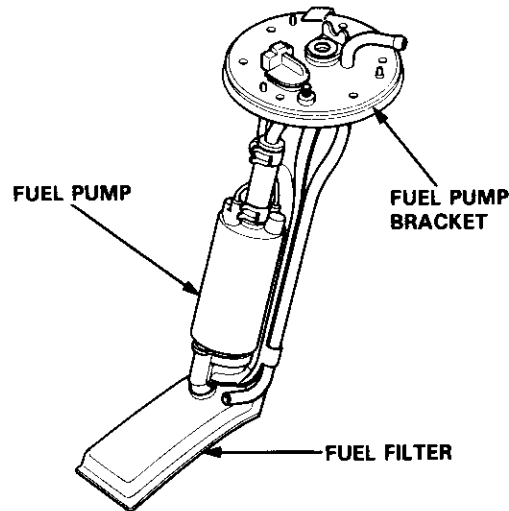

The fuel pump is comprised of a DC motor, a circumference flow pump, a relief valve for protecting the fuel line systems, a check valve for retaining residual pressure, an inlet port, and a discharge port. The fuel pump assembly consists of the impeller (driven by the motor), the fuel pump casing (which forms the pumping chamber), and the fuel pump cover.

OPERATION

- (1) When the engine is started, the PGM-FI main relay actuates the fuel pump, and the motor turns the impeller. Differential pressure is generated by the numerous grooves around the impeller.
- (2) Fuel entering the inlet port flows inside the motor from the pumping chamber and is forced through the discharge port via the check valve. If fuel flow is obstructed at the discharges side of the fuel line, the relief valve will open to bypass the fuel to the inlet port and prevent excessive fuel pressure.
- (3) When the engine stops, the fuel pump stops automatically. However, a check valve closes by spring action to retain the residual pressure in the line, helping the engine to restart more easily.



Testing

⚠ WARNING Do not smoke during the test. Keep open flame away from your work area.

If you suspect a problem with the fuel pump, check that the fuel pump actually runs; when it is ON, you will hear some noise if you hold your ear near the fuel fill port with the fuel fill cap removed. The fuel pump should run for two seconds when the ignition switch is first turned on. If there is no noise at the fuel fill port, check as follows:

1. Remove the access panel in trunk.

CAUTION: Be sure to turn the ignition switch OFF before disconnecting the wires.

2. Disconnect the 2P connector.
3. Disconnect the PGM-FI main relay connector and connect the BLK/YEL ⑤ wire and YEL ⑦ wire with a jumper wire.

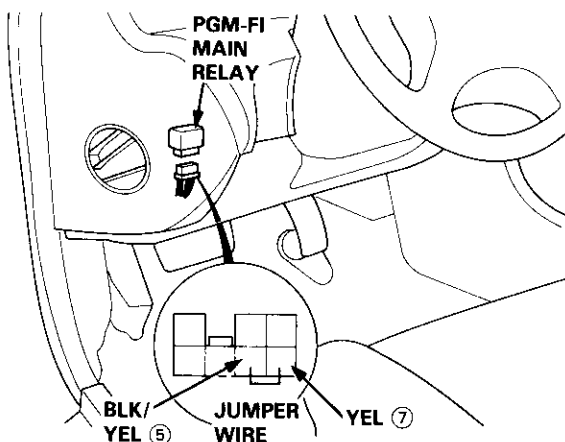

4. Check that battery voltage is available at the fuel pump connector when the ignition switch is turned ON (positive probe to the YEL wire, negative probe to the BLK wire).

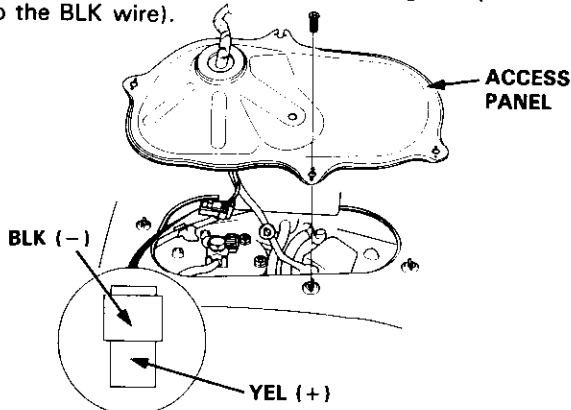

- If battery voltage is available, replace the fuel pump.
- If there is no voltage, check the fuel pump ground and wire harness (see page 11-128).

Replacement

⚠ WARNING Do not smoke while working on fuel system. Keep open flames away from your work area.

1. Relieve fuel pressure (see page 11-114).
2. Remove the access panel in trunk.
3. Disconnect the 2P connector from the fuel pump.
4. Remove the fuel pump mounting nuts.
5. Remove the fuel pump from the fuel tank.

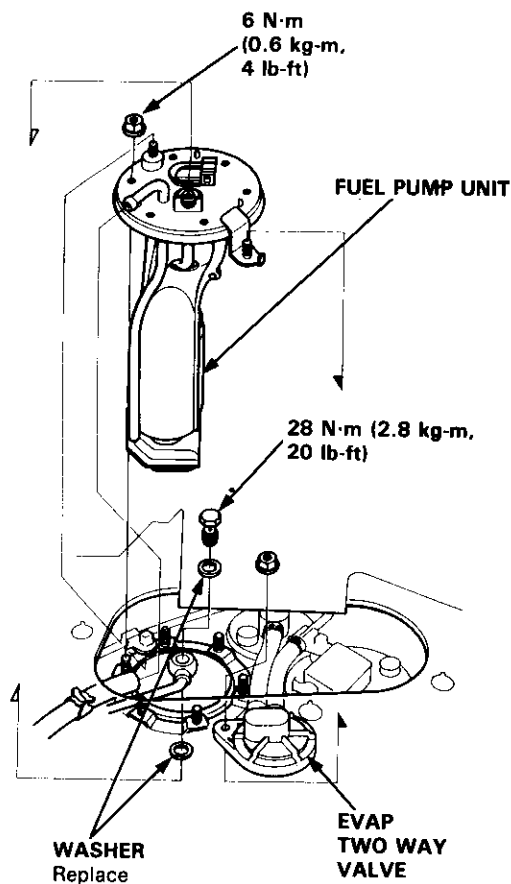

Fuel Supply System

PGM-FI Main Relay

Description

The PGM-FI main relay actually contains two individual relays.

The relay is located at the left side of the cowl.

One relay is energized whenever the ignition is on which supplies the battery voltage to the ECM, power to the fuel injectors, and power for the second relay.

The second relay is energized for 2 seconds when the ignition is switched on, and when the engine is running which supplies power to the fuel pump.

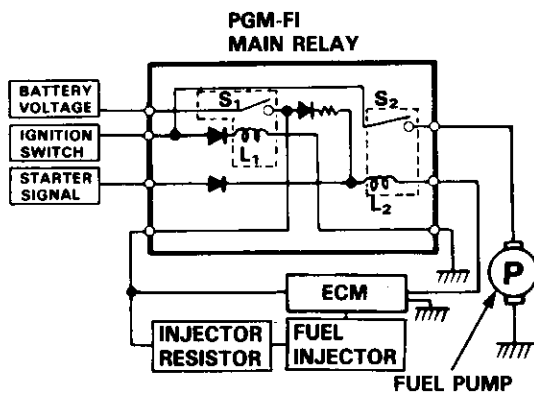

Relay Testing

NOTE: If the car starts and continues to run, the PGM-FI main relay is OK.

1. Remove the PGM-FI main relay.
2. Attach the battery positive terminal to the No. 6 terminal and the battery negative terminal to the No. 8 terminal of the PGM-FI main relay. Then check for continuity between the No. 5 terminal and No. 7 terminal of the PGM-FI main relay.

- If there is continuity, go on to step 3.
- If there is no continuity, replace the relay and retest.

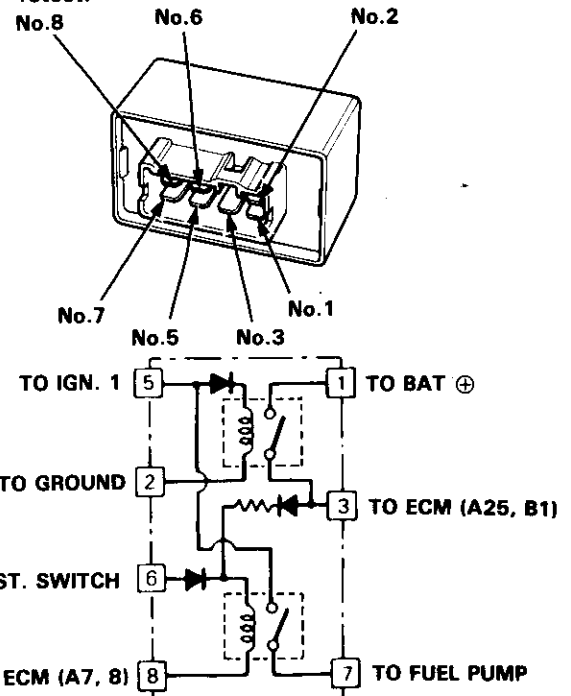

3. Attach the battery positive terminal to the No. 5 terminal and the battery negative terminal to the No. 2 terminal of the PGM-FI main relay. Then check that there is continuity between the No. 1 terminal and No. 3 terminal of the PGM-FI main relay.

- If there is continuity, go on to step 4.
- If there is no continuity, replace the relay and retest.

4. Attach the battery positive terminal to the No. 3 terminal and the battery negative terminal to the No. 8 terminal of the PGM-FI main relay. Then check that there is continuity between the No. 5 terminal and No. 7 terminal of the PGM-FI main relay.

- If there is continuity, the relay is OK.
- If there is no continuity, replace the relay and retest.

(cont'd)

Fuel Supply System

PGM-FI Main Relay (cont'd)

Troubleshooting Flowchart

— Engine will not start.
— Inspection of PGM-FI main relay.

Disconnect the PGM-FI main relay connector.

Check for continuity between BLK terminal ② and body ground.

Is there continuity? NO
 YES

Repair open in BLK wire between PGM-FI main relay and G101 (located at thermostat housing).

Measure the voltage between YEL/BLU terminal ① and body ground.

Is there battery voltage? NO
 YES

— Replace the No. 4 BACK UP (10 A) fuse (in the under-dash fuse/relay box).
— Repair open in the YEL/BLU wire between the PGM-FI main relay and the No. 4 BACK UP (10 A) fuse.

Turn the ignition switch ON.

Measure the voltage between BLK/YEL terminal ⑤ and body ground.

Is there battery voltage? NO
 YES

— Replace the ECU (ECM) (15 A) fuse (in the under-dash fuse/relay box).
— Repair open in the BLK/YEL wire between the PGM-FI main relay and the ECU (ECM) (15 A) fuse.

Turn the ignition switch to the START position.

Measure the voltage between BLU/RED terminal ⑥ and body ground.

Is there battery voltage? NO
 YES

— Replace the No. 2 STARTER SIGNAL (7.5 A) fuse (in the under-dash fuse/relay box).
— Repair open in the BLU/RED wire between the PGM-FI main relay and the ignition switch (ST).

(To page 11-129)

NOTE:

- M/T: Clutch pedal must be depressed.
- A/T: transmission in n or P position.

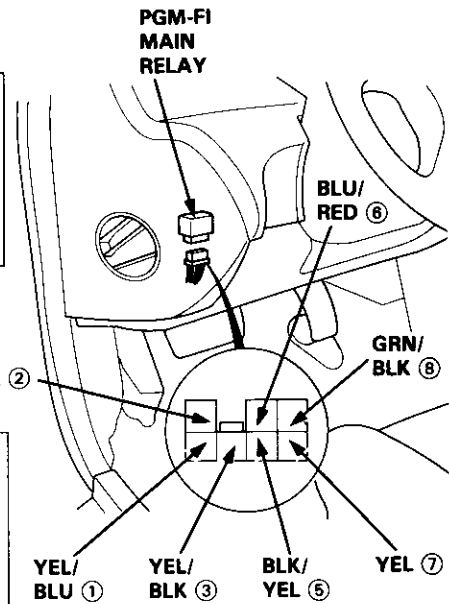



(From page 11-128)

Turn the ignition switch OFF.

Connect the test harness between the ECM and connectors. Disconnect "A" connector from the ECM only, not the main wire harness (see page 11-45).

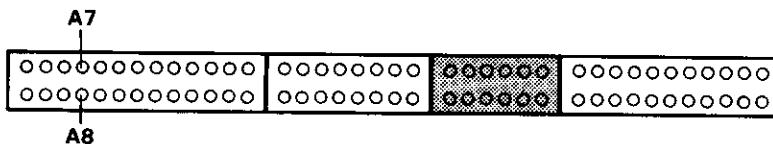

Check for continuity between GRN/BLK terminal ⑧ and the following terminals; A7, A8.

Is there continuity?

NO

Repair open in GRN/BLK wire between ECM (A7, A8) and PGM-FI main relay.

YES

Reconnect "A" connector to the ECM.

Connect the PGM-FI main relay connector.

Battery voltage?

A23 (-) A25 B1 (+) (+)

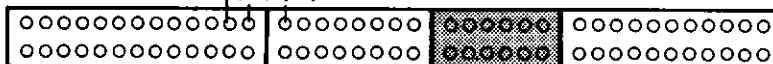

Turn the ignition switch ON.

Measure the voltage between A23 (-) terminal and the following terminals: A25 (+) B1 (+).

Is there battery voltage?

NO

- Repair open in the YEL/BLK ③ wire between the ECM (A25, B1) and PGM-FI main relay.
- Replace PGM-FI main relay.

YES

Turn the ignition switch OFF.

Battery voltage?

A7 (+) A23 (-)

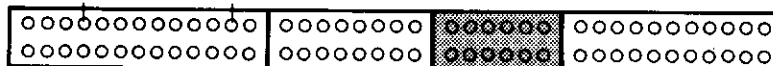

Connect a voltmeter between A7 (+) terminal and A23 (-) terminal.

Is there battery voltage for two seconds when the ignition switch is first turned on?

YES

Substitute a known-good ECM and recheck. If prescribed voltage is now available, replace the original ECM.

NO

Check the PGM-FI main relay (see page 11-126).

Fuel Supply System

Fuel Tank

Replacement

⚠ WARNING Do not smoke while working on fuel system. Keep open flame away from your work area.

1. Block front wheels. Jack up the rear of the car and support with jackstands.
2. Remove the drain bolt and drain the fuel into an approved container.
3. Remove the access panel.
4. Disconnect the connectors from the fuel gauge sending unit and the fuel pump, then remove the fuel feed line and return hose.

CAUTION: Be sure to turn the ignition switch OFF before disconnecting the wires.

5. Remove the fuel hose protectors.
6. Disconnect the hoses.

CAUTION: When disconnecting the hoses, slide back the clamps, then twist hoses as you pull to avoid damaging them.

7. Place a jack, or other support, under the tank.
8. Remove the strap bolts and nuts, and let the straps fall free.
9. Remove the fuel tank.

NOTE: The tank may stick on the undercoat applied to its mount. To remove, carefully pry it off the mount.

10. Install a new washer on the drain bolt and the fuel pump line, then install parts in the reverse order of removal.

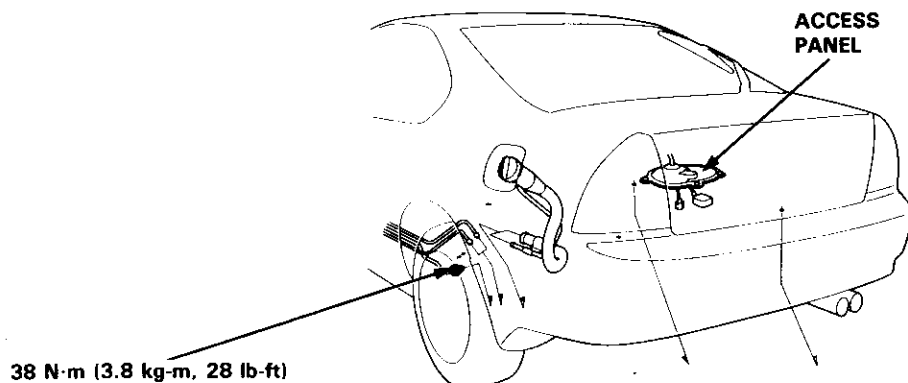

CAUTION: Clean the flared joint of high pressure hoses thoroughly before reconnecting them.

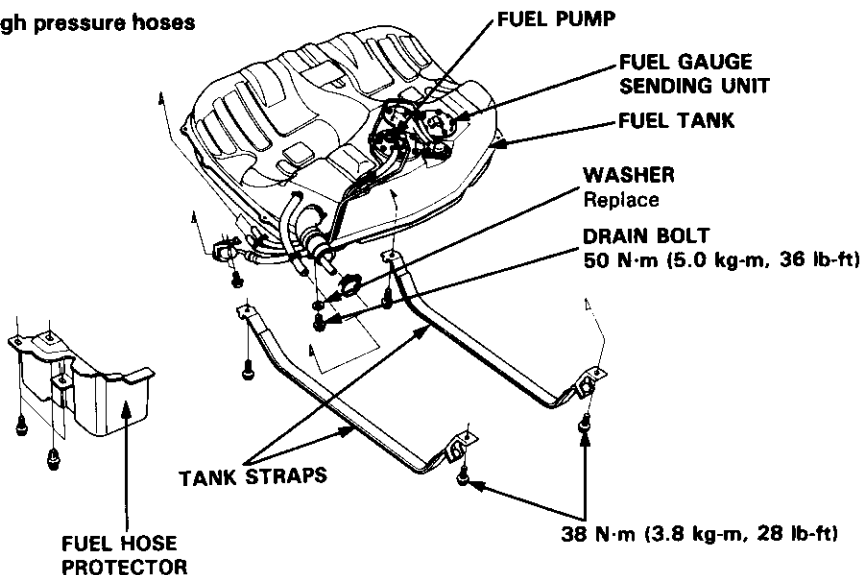

Intake Air System

System Troubleshooting Guide



NOTE: Across each row in the chart, the sub-systems that could be sources of a symptom are ranked in the order they should be inspected starting with ①. Find the symptom in the left column, read across to the most likely source, then refer to the page listed at the top of the column. If inspection shows the system is OK, try the next system ②, etc.

PAGE	SUB-SYSTEM	THROTTLE CABLE	THROTTLE BODY	*INTAKE CONTROL SYSTEM	*INTAKE AIR BYPASS CONTROL SYSTEM
		138	139	134	143
SYMPTOM					
WHEN COLD FAST IDLE OUT OF SPEC		③	②		①
WHEN WARM IDLE TOO HIGH		②	①		
LOSS OF POWER		①		③	②

*: Except F22A1-engine(S)

Intake Air System

System Description

The system supplies air for all engine needs. It consists of the Air Cleaner (ACL), intake air pipe, intake air duct, Throttle Body (TB), Idle Air Control (IAC) Valve, fast idle thermo valve, *Intake Air Bypass (IAB) Control System, *intake control system, and intake manifold. A resonator in the intake air pipe provides additional silencing as air is drawn into the system.

*: Except F22A1 engine (S)

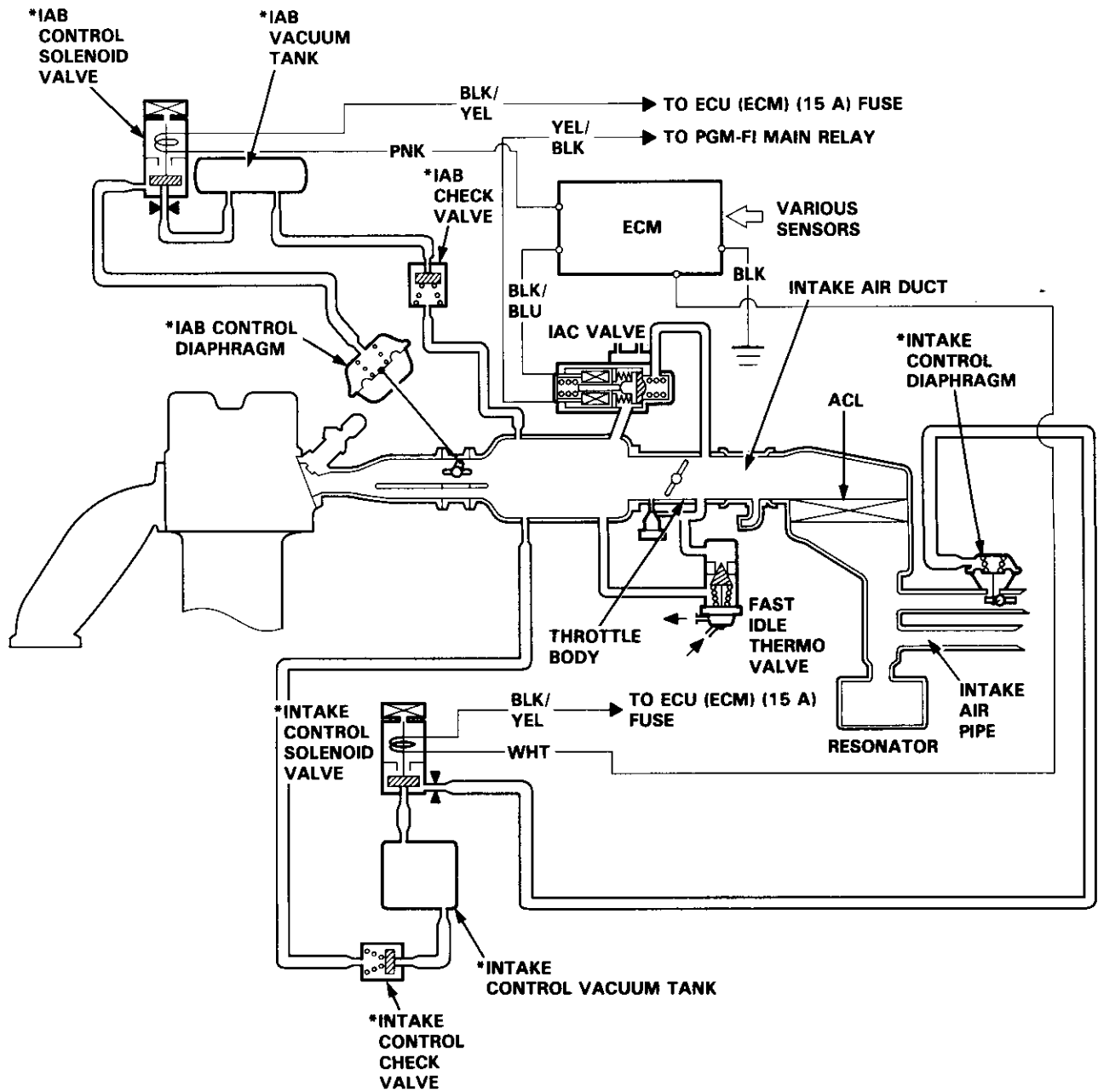



Air Cleaner (ACL)

Air Cleaner (ACL) Element Replacement

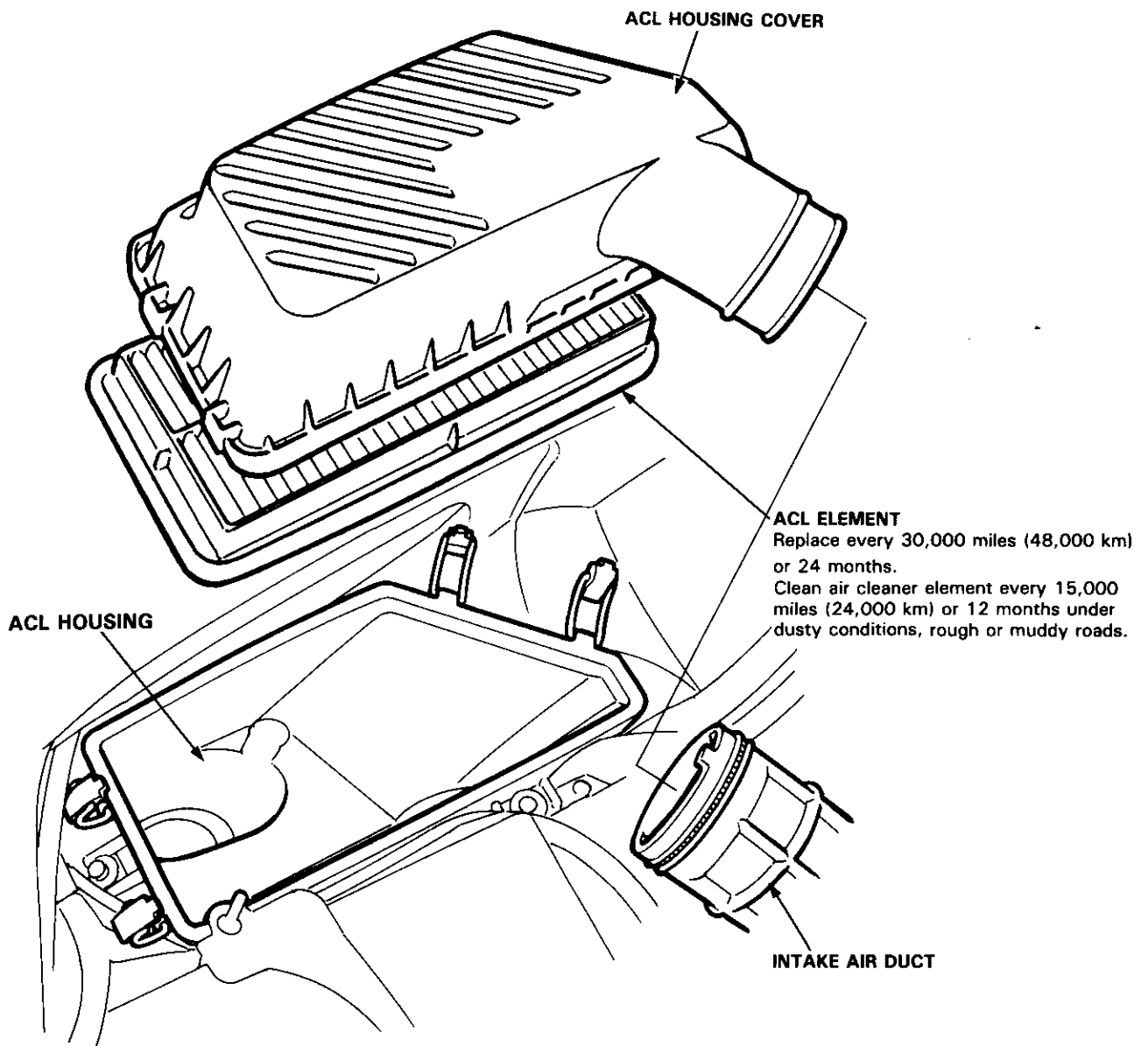

Intake Air System

Intake Control System [Except F22A1 engine (S)]

Description

The intake control system decreases air intake noise.

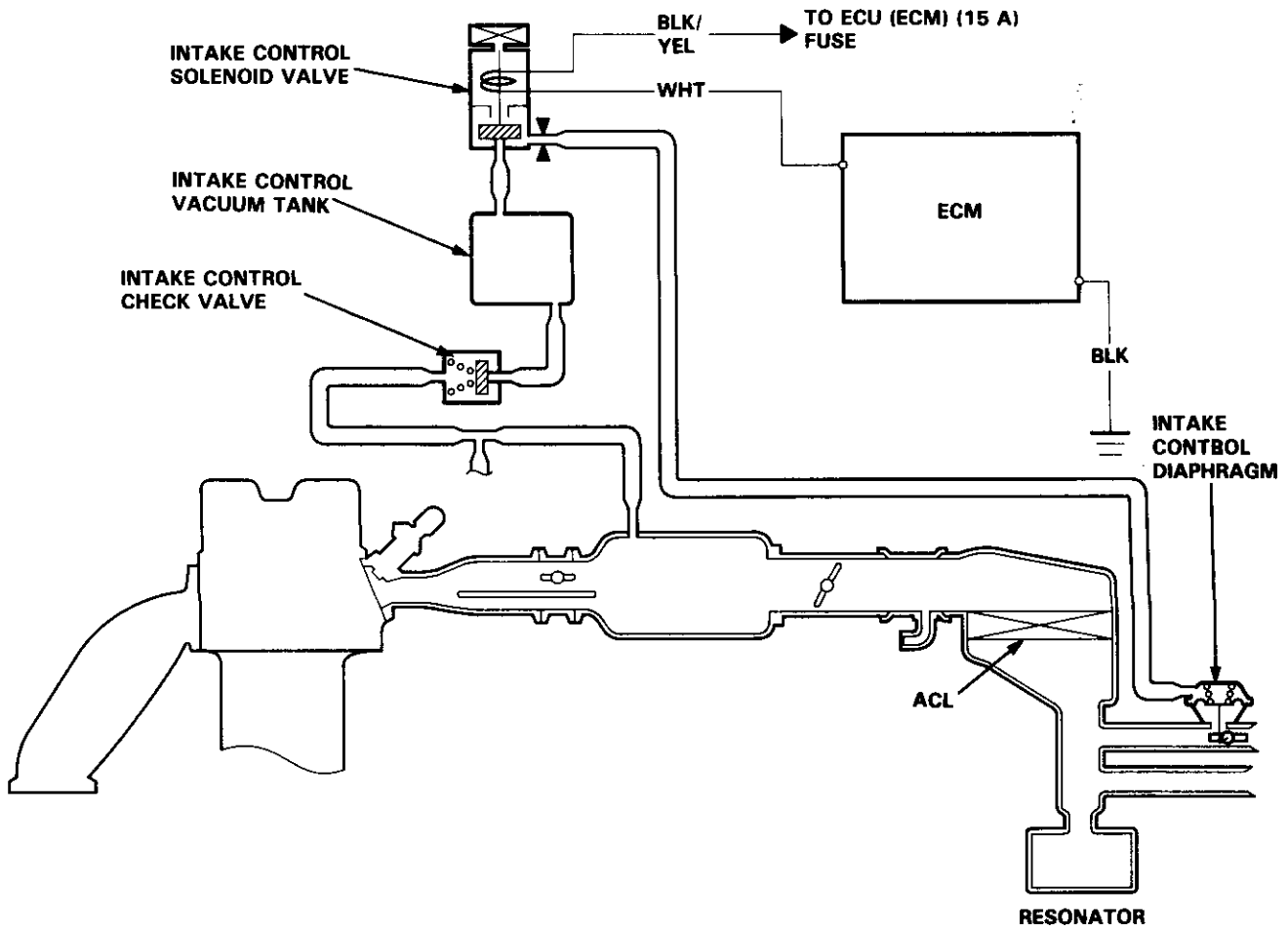

When the engine speed is below 4,000 rpm, the ECM provides ground for the intake control solenoid valve. This opens the solenoid valve sending intake manifold vacuum to the intake control diaphragm.



Troubleshooting Flowchart

Inspection of Intake Control System

Start engine and allow to idle.

Remove the #8 vacuum hose from the hose joint and connect a vacuum gauge to the solenoid valve.

VACUUM PUMP/GAUGE
A973X-041-XXXXX

INTAKE CONTROL SOLENOID VALVE

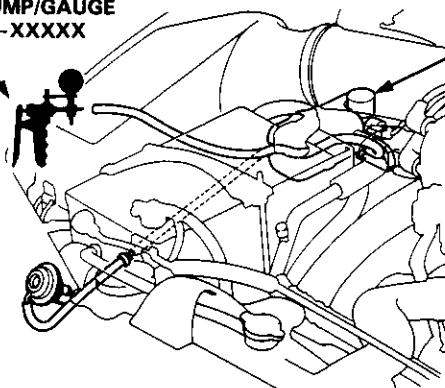

Is there vacuum?

NO

Disconnect the lower vacuum hose of the solenoid valve from the air chamber and connect a vacuum gauge to the hose.

YES

Is there manifold vacuum?

NO

- Check the vacuum line for proper connection, cracks, blockage or disconnected hose.
- Clean manifold port.

YES

Disconnect the 2P connector from the intake control solenoid valve.

Measure voltage between BLK/YEL (+) terminal and WHT (-) terminal.

INTAKE CONTROL SOLENOID VALVE

BLK/YEL (+)

WHT (-)

YES

Replace the intake control solenoid valve.

NO

Measure voltage between BLK/YEL (+) terminal and body ground.

(To page f1-136)

(To page 11-136)

(cont'd)

Intake Air System

Intake Control System [Except F22A1 engine (S)] (cont'd)

(From page 11-135)

(From page 11-135)

Raise engine speed to 4,200 rpm.

Is there battery voltage?

NO

Repair open in BLK/YEL wire between the 2P connector and ECU (ECM) (15 A) fuse (in the under-dash fuse/relay box).

YES

Turn the ignition switch OFF.

Reconnect the 2P solenoid connector.

Connect the test harness between the ECM and connectors (see page 11-45).

Turn the ignition switch ON.

Connect a jumper wire between A19 terminal and A26 terminal.

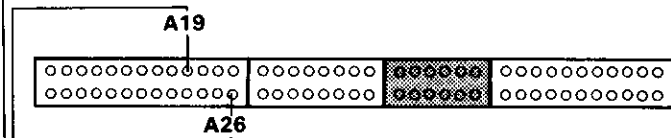

Does solenoid valve click when the jumper is connected?

NO

Repair open in WHT wire between ECM (A19) and the 2P connector.

YES

Substitute a known-good ECM and recheck. If symptom/indication goes away, replace the original ECM.

Is there vacuum?

YES

Disconnect the 2P connector.

NO

Is there vacuum?

YES

Replace intake control solenoid valve.

NO

Turn the ignition switch OFF.

Disconnect "A" connector from ECM.

Check for continuity to ground on WHT wire.

(To page 11-137)

(To page 11-137)



(From page 11-136)

(From page 11-136)

Is there continuity?

YES

Repair short to ground in WHT wire between ECM (A19) and the 2P connector.

NO

Substitute a known-good ECM and recheck. If symptom goes away, replace the original ECM.

Connect a vacuum pump to the #8 vacuum hose.

Apply the vacuum.

Does it hold vacuum?

NO

Check the vacuum line for proper connection or disconnected hose. If OK, replace the intake control diaphragm.

YES

Intake control system is OK.

INTAKE CONTROL DIAPHRAGM

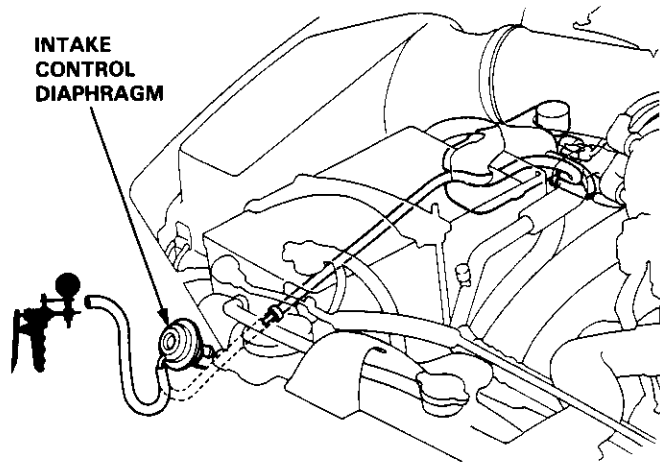

Intake Air System

Throttle Cable

Inspection/Adjustment

1. Warm up the engine to normal operating temperature (the radiator fan comes on).
2. Check that the throttle cable operates smoothly with no binding or sticking. Repair as necessary.
3. Check cable free play at the throttle linkage. Cable deflection should be 10–12 mm (0.39–0.47 in.)

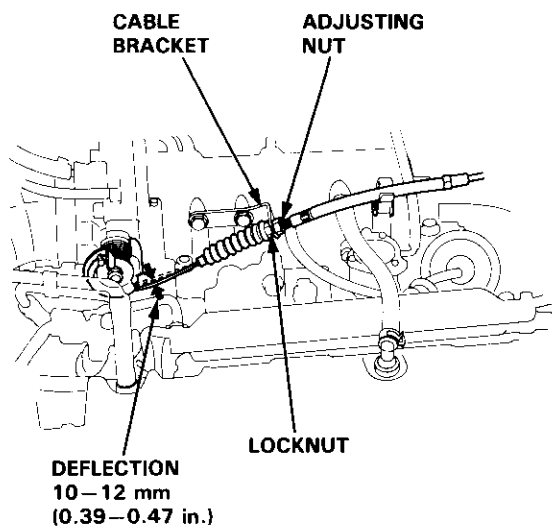

4. If deflection is not within specs, loosen the locknut, turn the adjusting nut until the deflection is as specified, then retighten the locknut.
5. With the cable properly adjusted, check the throttle valve to be sure it opens fully when you push the accelerator pedal to the floor. Also check the throttle valve to be sure it returns to the idle position whenever you release the accelerator pedal.

Installation

1. Fully open the throttle valve, then install the throttle cable in the throttle linkage and install the cable housing in the cable bracket.
2. Warm up the engine to normal operating temperature (the radiator fan comes on).

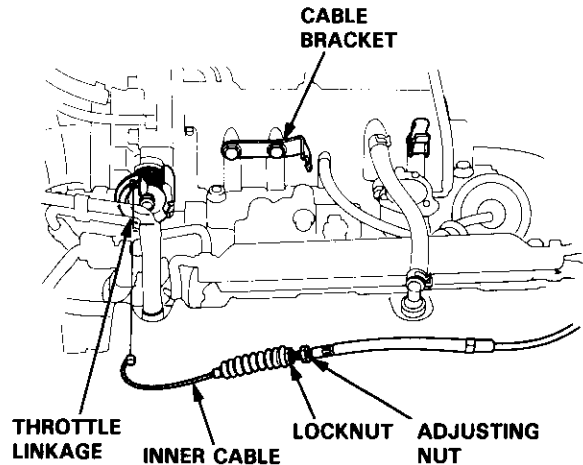

3. Hold the cable sheath, removing all slack from the cable.
4. Turn the adjusting nut until it is 3 mm (0.12 in.) away from the cable bracket.
5. Tighten the locknut. The cable deflection should now be 10–12 mm (0.39–0.47 in.). If not, see inspection/adjustment.

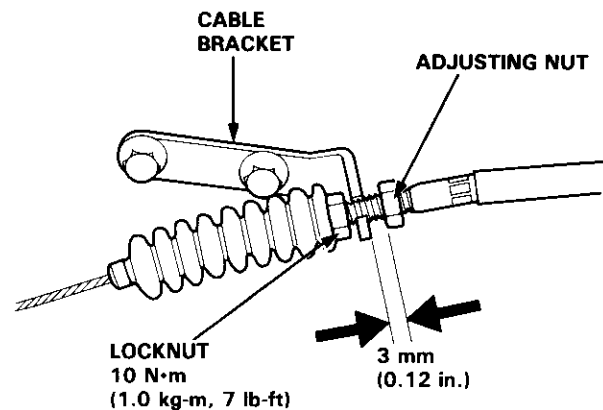



Throttle Body

Description

The throttle body is of the single-barrel side-draft type. The lower portion of the throttle valve is heated by engine coolant which is fed from the cylinder head. The idle adjusting screw which increases/decreases bypass air and the Evaporative Emission (EVAP) Control Canister port are located on the top of the throttle body.

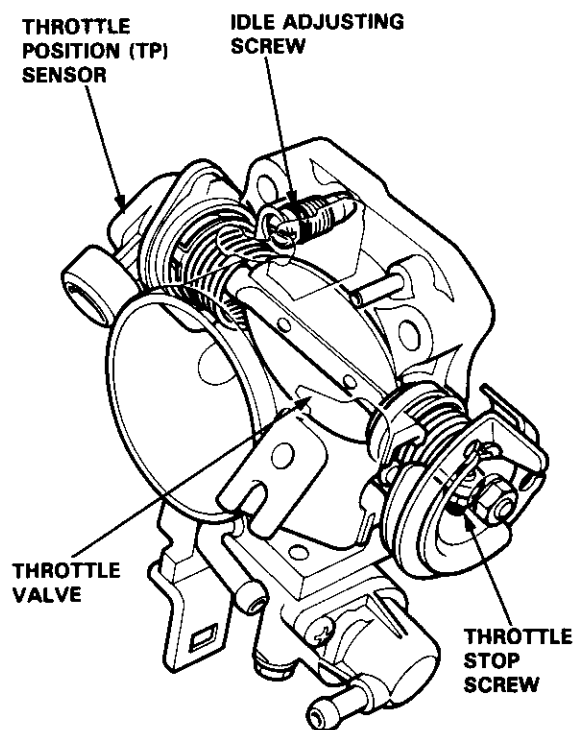

Inspection

CAUTION: Do not adjust the throttle stop screw. It is preset at the factory.

1. Start the engine and allow it to reach normal operating temperature (the radiator fan comes on).
2. Disconnect the vacuum hose (to the EVAP control canister) from the top of the throttle body; connect a vacuum gauge to the throttle body.

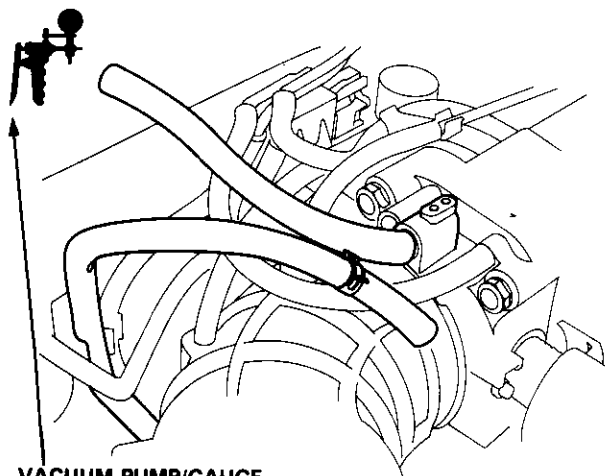

VACUUM PUMP/GAUGE
A973X-041-XXXXX

3. Allow the engine to idle and check that the gauge indicates no vacuum.
 - If there is vacuum, check the throttle cable (see page 11-138).
4. Check that vacuum is indicated on the gauge when the throttle is opened slightly from idle.
 - If the gauge indicates no vacuum, check the throttle body port. If the throttle body port is clogged, clean it with carburetor cleaner.
5. Stop the engine and check that the throttle cable operates smoothly without binding or sticking.
 - If there are any abnormalities in the above steps, check for:
 - Excessive wear or play in the throttle valve shaft.
 - Sticky or binding throttle lever at full close position.
 - Clearance between throttle stop screw and throttle lever at full close position.

(cont'd)

Intake Air System

Throttle Body (cont'd)

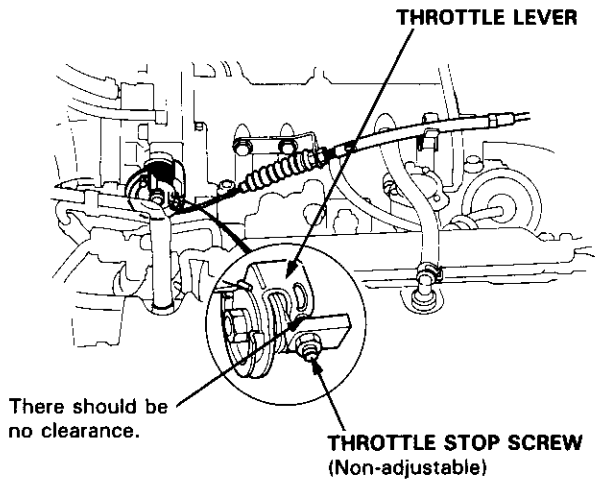

Replace the throttle body if there is excessive play in the throttle valve shaft or if the shaft is binding or sticking.



Throttle Body

Disassembly

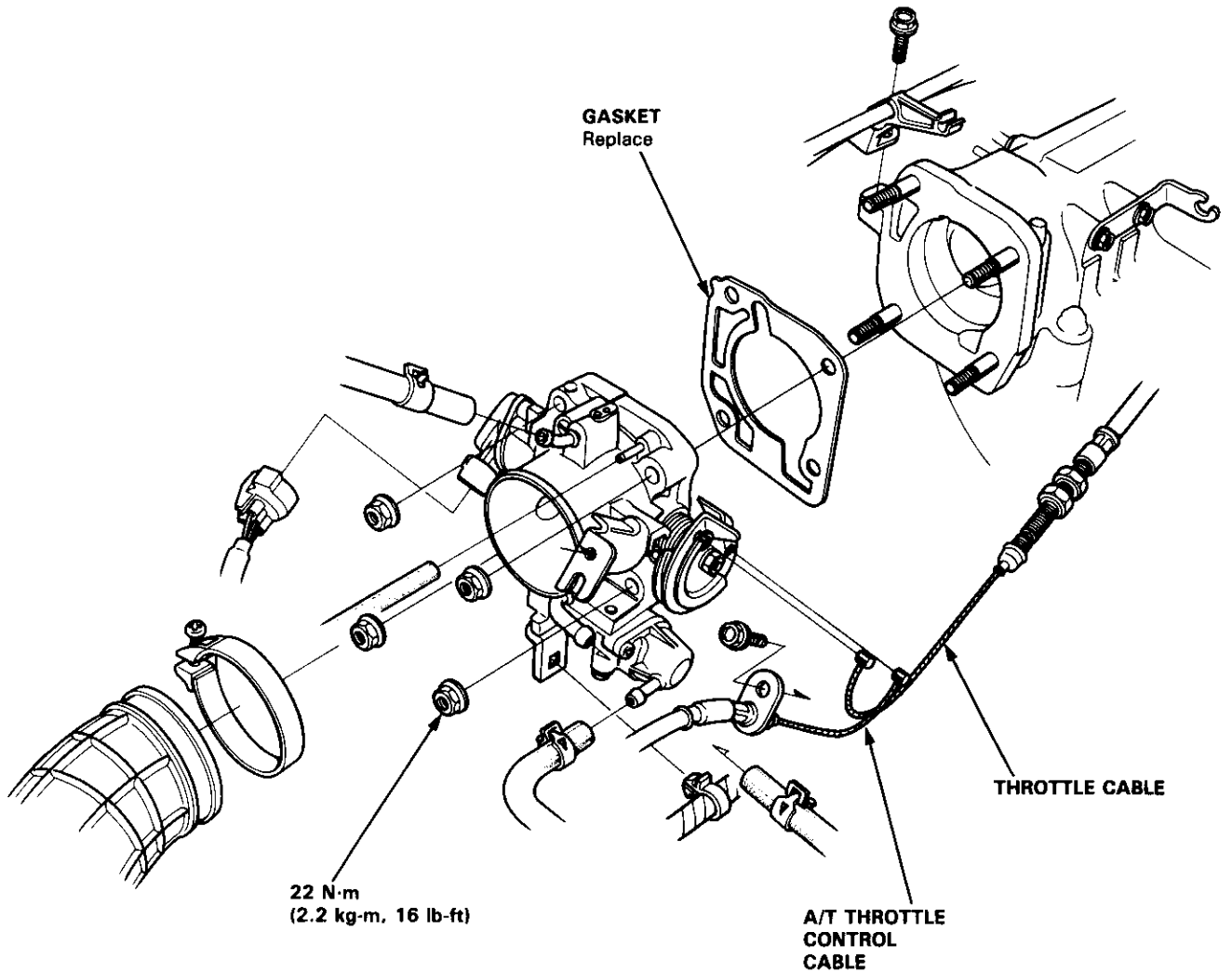

(cont'd)

Intake Air System

Throttle Body (cont'd)

CAUTION:

- The throttle stop screw is non-adjustable.
- After reassembly, adjust the throttle cable (see page 11-138), and A/T throttle control cable (see section 14) for cars with A/T.

F22A1 engine (S):

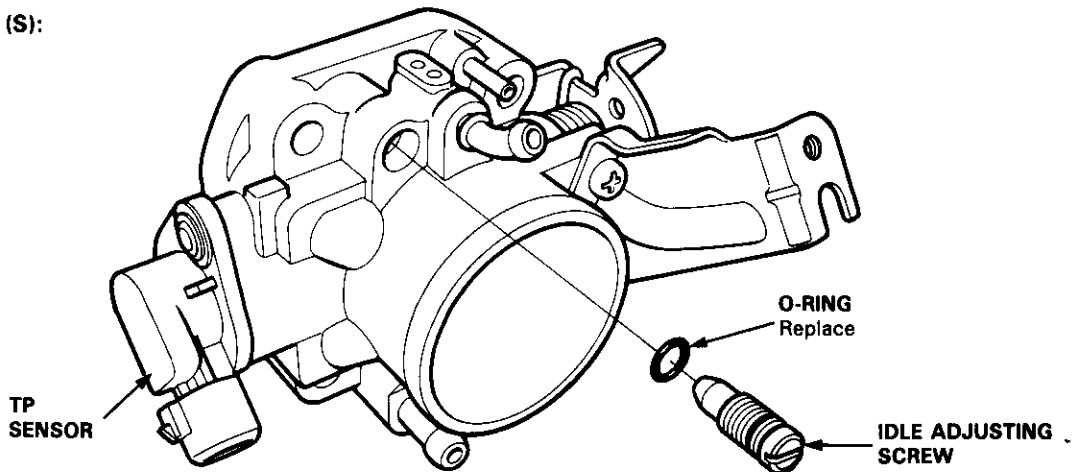

H23A1 engine (USA: Si/Canada: SR),
H22A1 engine (USA: Si VTEC/Canada: SR-V):

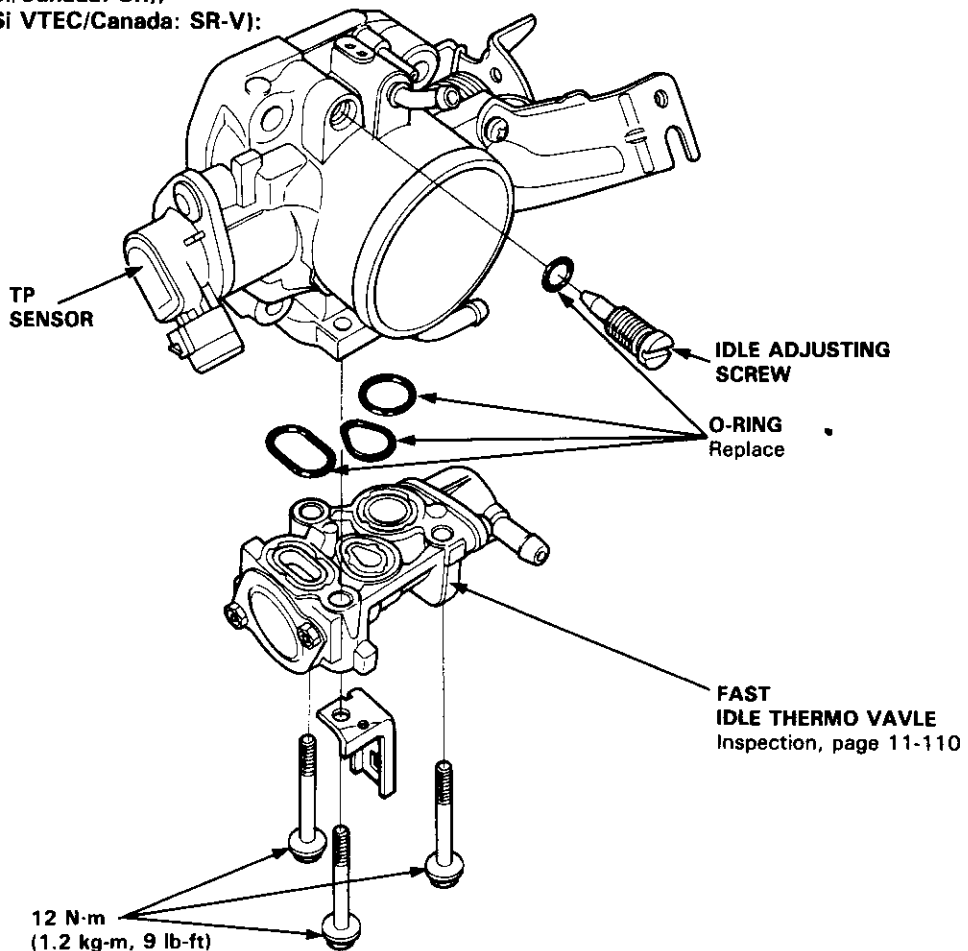



Intake Air Bypass (IAB) Control System [Except F22A1 engine (S)]

Description

Two air intake paths are provided in the intake manifold to allow the selection of the intake path most favorable for a given engine speed.

Optimum performance at any RPM is achieved by closing and opening the Intake Air Bypass (IAB) valves. High torque at low RPM is achieved when the IAB valves are closed, whereas high power at high RPM is achieved when the IAB valves are opened.

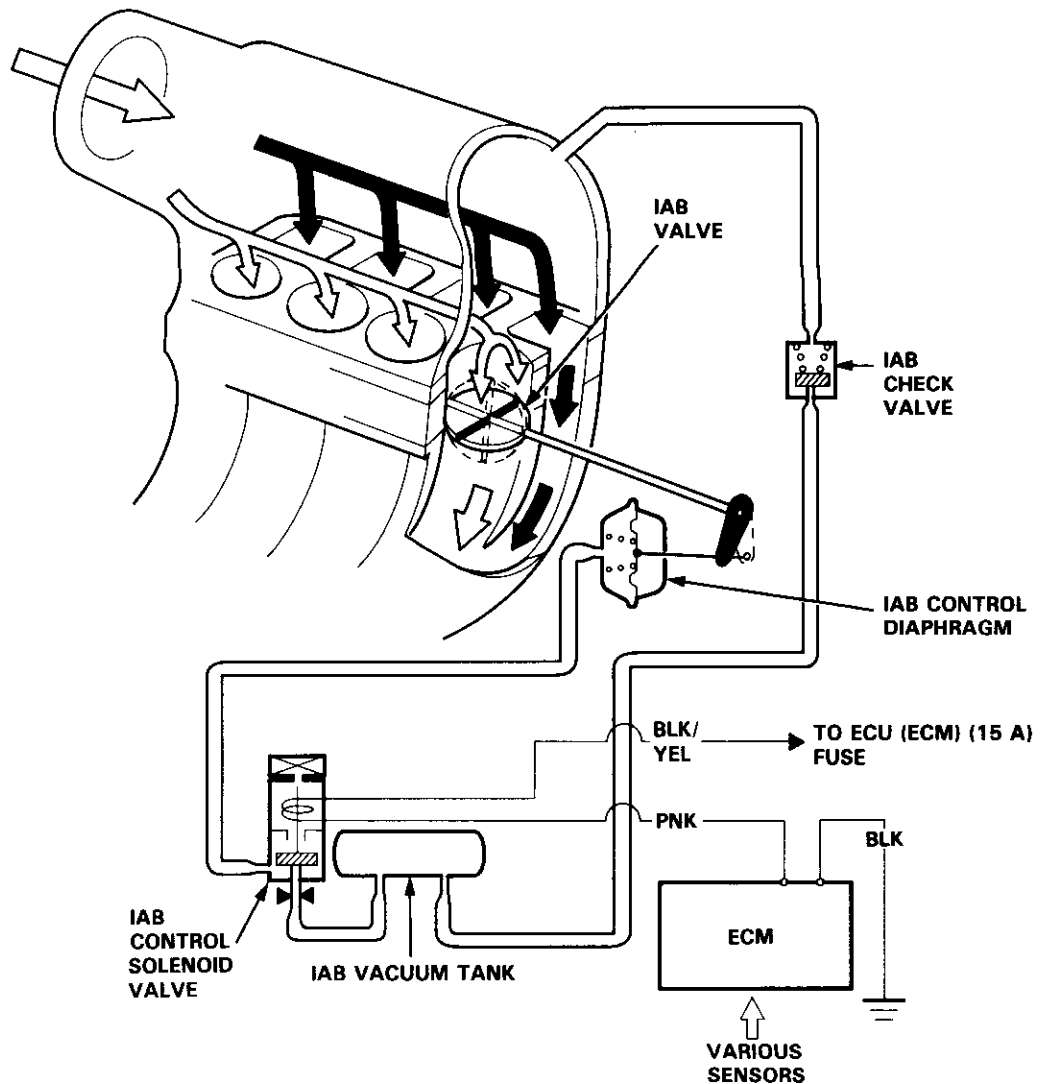

IAB CONTROL SOLENOID VALVE OFF

ENGINE RPM IS ABOVE
4,800 rpm (H23A1 engine)
or 4,600 rpm (H22A1 engine)

(cont'd)

Intake Air System

Intake Air Bypass (IAB) Control System [Except F22A1 engine (S)] (cont'd)

Troubleshooting Flowchart

Inspection of IAB Control System

Start engine and allow to idle.

Remove # 13 vacuum hose from the IAB control diaphragm and connect vacuum gauge to the hose.

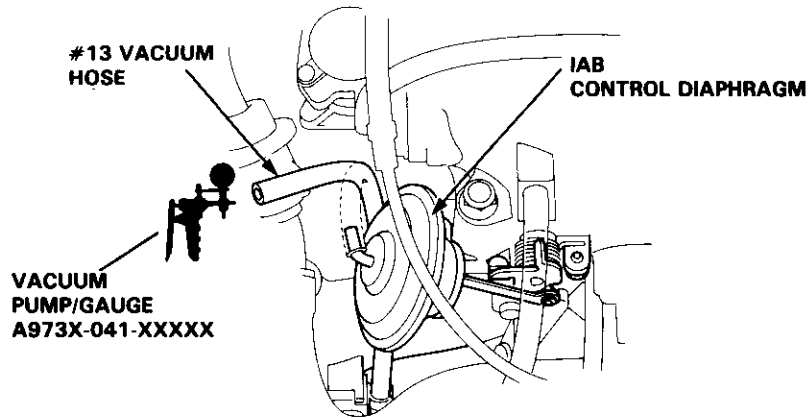

Is there vacuum ?

NO

Disconnect the 2P connector from the IAB control solenoid valve.

Measure voltage between BLK/YEL (+) terminal and PNK (-) terminal.

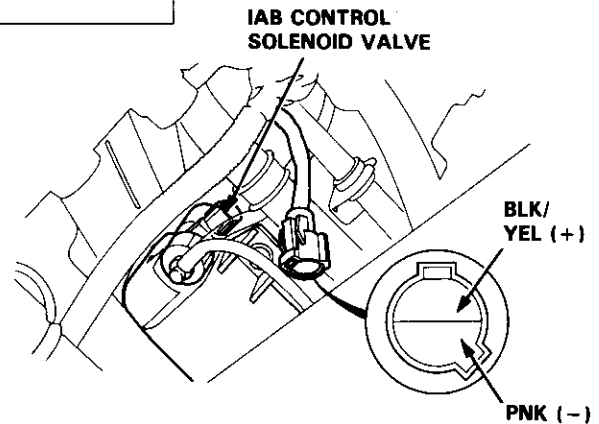

Is there battery voltage ?

YES

Repair the blockage or vacuum leak between the intake manifold and diaphragm, if vacuum is OK, replace the IAB control solenoid valve.

NO

Measure voltage between BLK/YEL (+) terminal and body ground.

Is there battery voltage ?

NO

Repair open in BLK/YEL wire between the 2P connector and ECU (ECM) (15 A) fuse (in the under-dash fuse/relay box).

YES

Turn the ignition switch OFF.

(To page 11-145)

(To page 11-145)



(From page 11-144)

Raise engine speed to 5,000 rpm.

Check for vacuum at #13 vacuum hose.

Is there vacuum ?

NO

IAB control system is OK.

(From page 11-144)

Reconnect the 2P connector to the IAB control solenoid valve.

Connect the test harness to the main wire harness only (see page 11-45).

Turn the ignition switch ON and connect a jumper wire between A17 terminal and A26 terminal.

Does the solenoid valve click when the jumper is connected?

NO

Repair open in PNK wire between ECM (A17) and the 2P connector. If the wire is OK, replace the IAB control solenoid valve.

YES

Substitute a known-good ECM and recheck. If prescribed voltage is now available replace the original ECM.

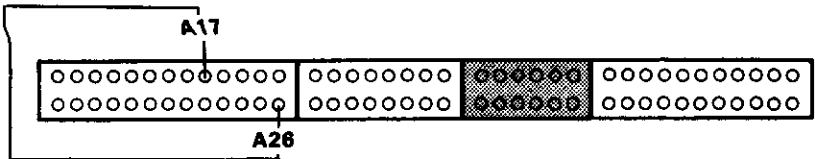

Disconnect the 2P connector from the IAB control solenoid valve.

Is there vacuum ?

YES

Replace the IAB control solenoid valve

NO

Turn the ignition switch OFF.

Disconnect "A" connector from ECM.

Check for continuity to ground on the PNK wire.

Is there continuity?

YES

Repair short to ground at PNK wire between ECM (A17) and the 2P connector.

NO

Substitute a known-good ECM and recheck. If symptom goes away, replace the original ECM.

(cont'd)

Intake Air System

Intake Air Bypass (IAB) Control System [Except F22A1 engine (S)] (cont'd)

IAB Valve Testing

CAUTION: Do not adjust the IAB valve full-close screw. It was preset at the factory.

1. Check the IAB valve shaft for binding or sticking.
2. Check the IAB valve for smooth movement.
3. With the engine OFF, check that (A) of the bypass valve is in close contact with the stopper.

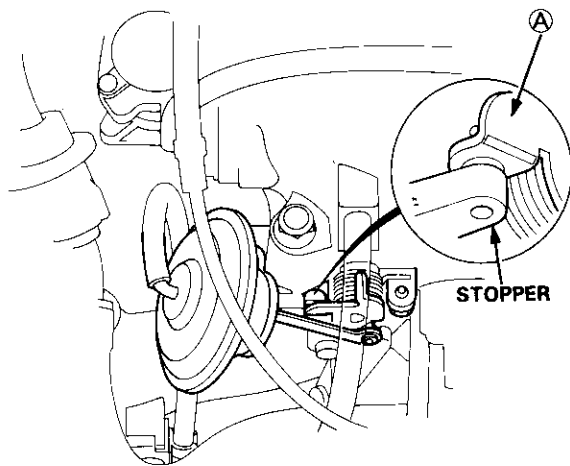

4. With the engine at idle, check that (B) of the IAB valve is in close contact with the full-close screw.

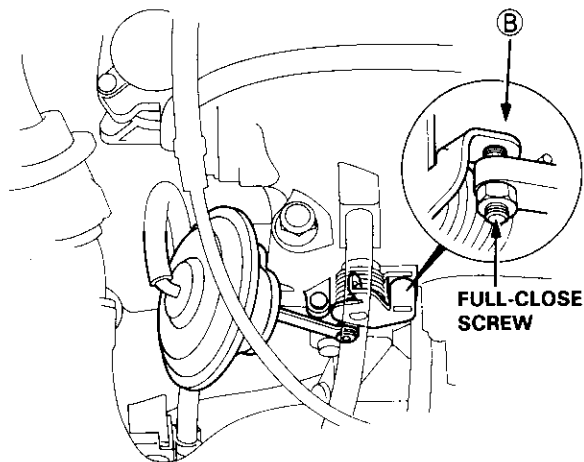

● If any fault is found, clean the linkage and shafts with carburetor cleaner.

— If the problem still exists after cleaning, disassemble the intake manifold and check the IAB valve (see page 11-147)



Intake Air Bypass (IAB) Control System [Except F22A1 engine (S)]

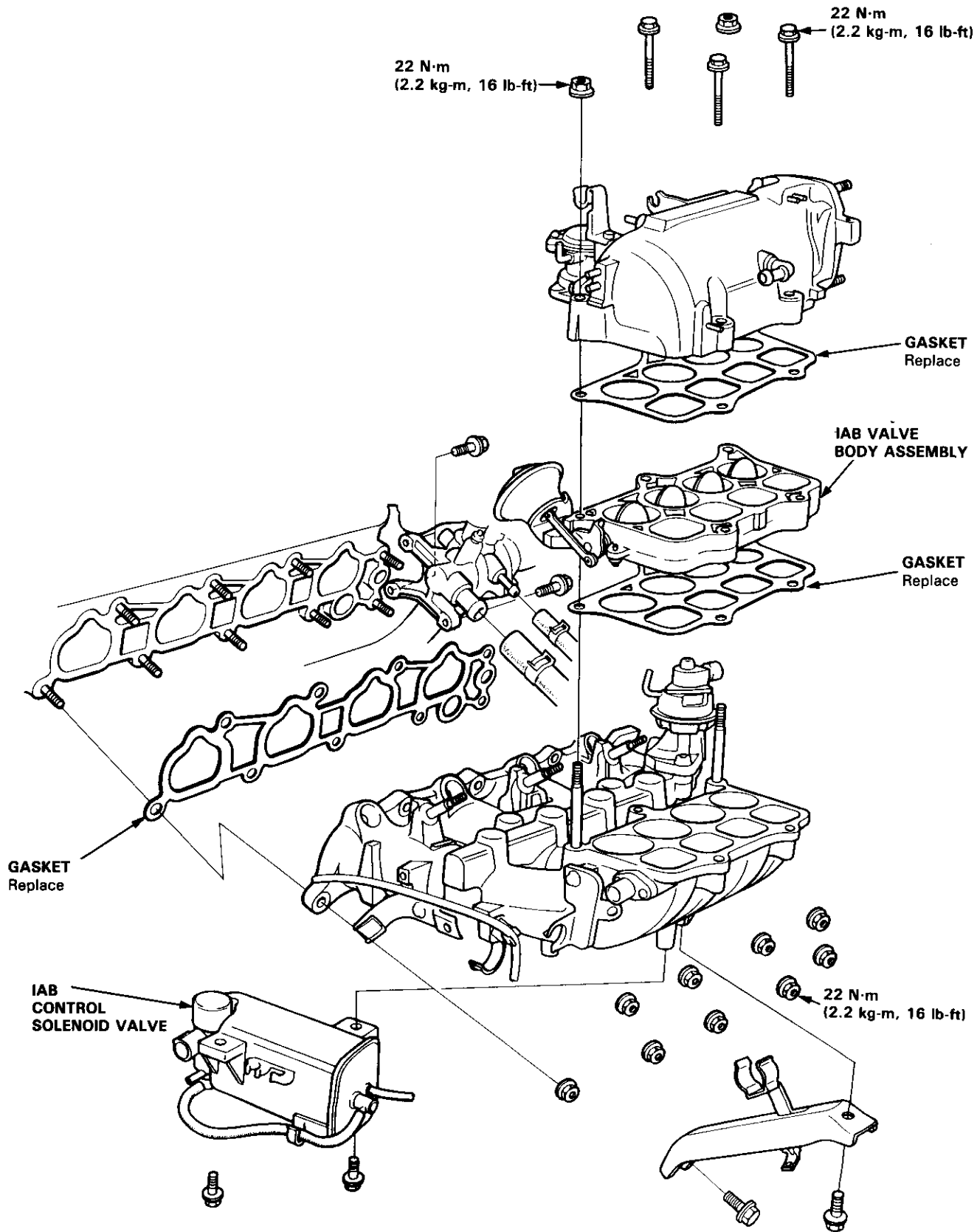

Intake Air System

Intake Manifold [F22A1 engine (S)]

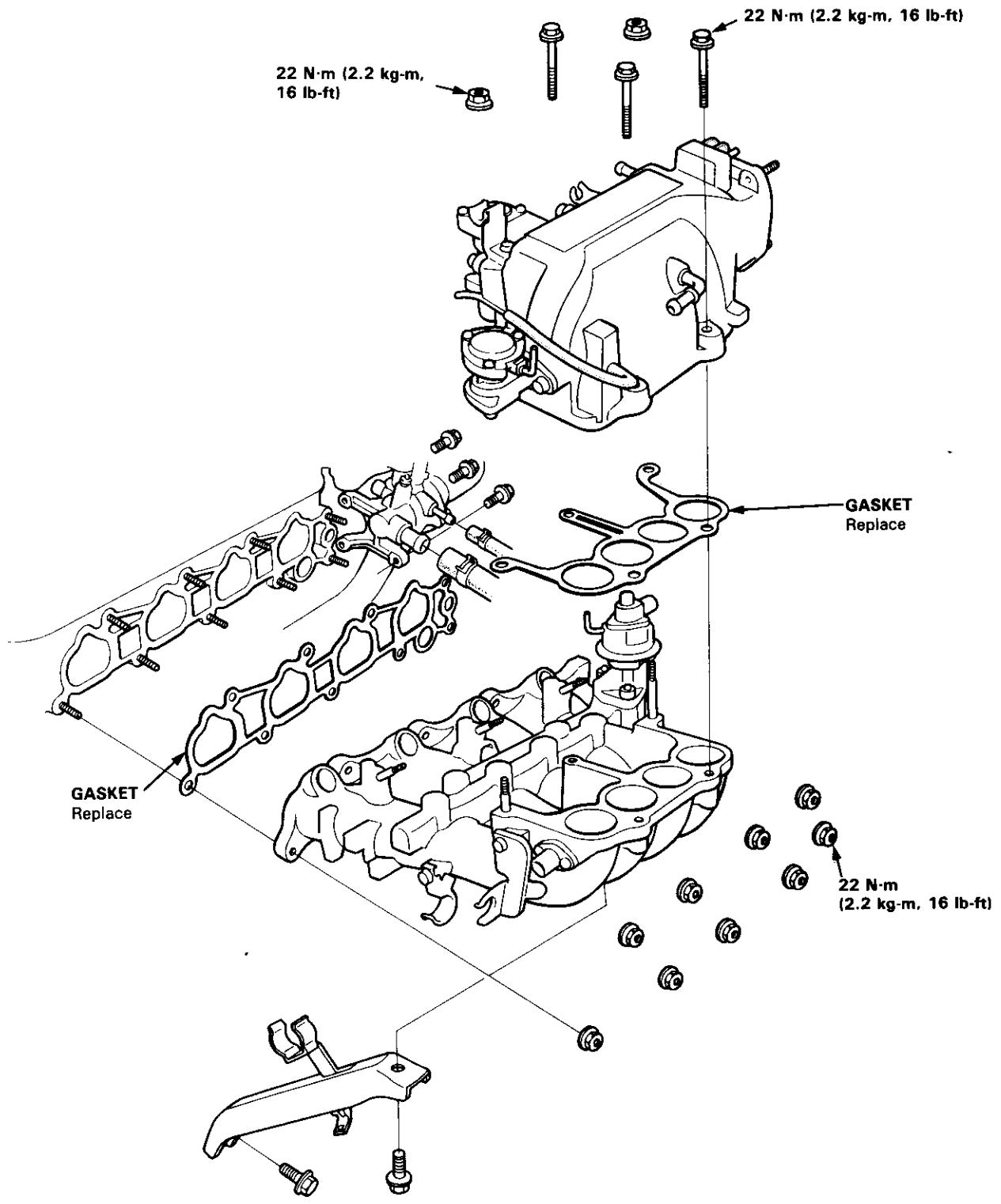

Emission Control System

System Troubleshooting Guide



NOTE: Across each row in the chart, the sub-systems that could be sources of a symptom are ranked in the order they should be inspected starting with ①. Find the symptom in the left column, read across to the most likely source, then refer to the page listed at the top of that column. If inspection shows the system is OK, try the next most likely system ②, etc.

PAGE	SUB-SYSTEM	THREE WAY CATALYTIC CONVERTER	EXHAUST GAS RECIRCULATION SYSTEM	POSITIVE CRANKCASE VENTILATION SYSTEM	EVAPORATIVE EMISSION CONTROLS
	SYMPTOM	151	153	159	160
	ROUGH IDLE		①	②	
	FREQUENT STALLING		①		
	AFTER WARMING UP		①		
	MISFIRE OR ROUGH RUNNING		①		
	POOR PERFORMANCE				
	FAILS EMISSION TEST	①	③		②
	LOSS OF POWER	①	②		

Emission Control System

System Description

The emission control system includes a Three Way Catalytic Converter (TWC), Exhaust Gas Recirculation (EGR) system, Positive Crankcase Ventilation (PCV) system and Evaporative Emission (EVAP) control system. The emission control system is designed to meet federal and state emission standards.

Tailpipe Emission

Inspection

▲ WARNING Do not smoke during this procedure. Keep any open flame away from your work area.

1. Start the engine and warm up to normal operating temperature by driving on the road.
2. Connect a tachometer.
3. Check and adjust the idle speed, if necessary (see page 11-111).
4. Warm up and calibrate the CO meter according to the meter manufacturer's instructions.
5. Check idle CO with the headlights, heater blower, rear window defogger, cooling fan, and air conditioner off.

CO meter should indicate 0.1 % maximum. -



Three Way Catalytic Converter (TWC)

Description

The Three Way Catalytic Converter (TWC) is used to convert hydrocarbons (HC), carbon monoxide (CO), and oxides of nitrogen (NOx) in the exhaust gas to carbon dioxide (CO₂), dinitrogen (N₂) and water vapor.

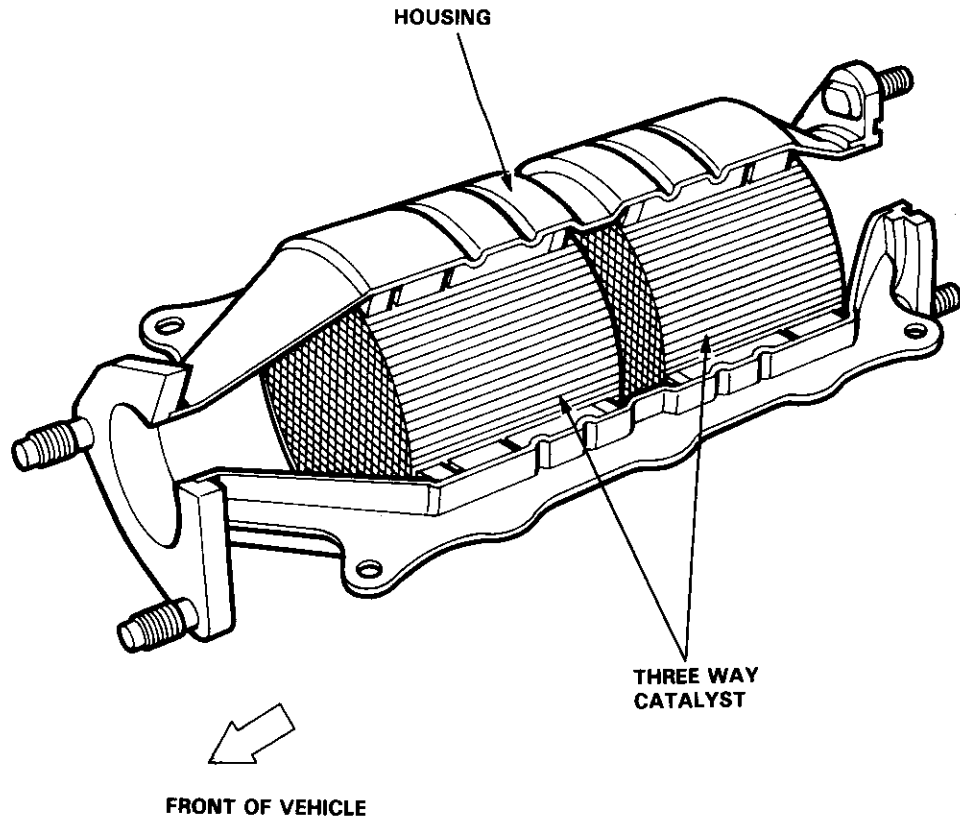

(cont'd)

Emission Control System

Three Way Catalytic Converter (TWC) (cont'd)

Inspection

If excessive exhaust system back-pressure is suspected, remove the TWC from the car and make a visual check for plugging, melting or cracking of the catalyst. Replace the TWC if any of the visible area is damaged or plugged.

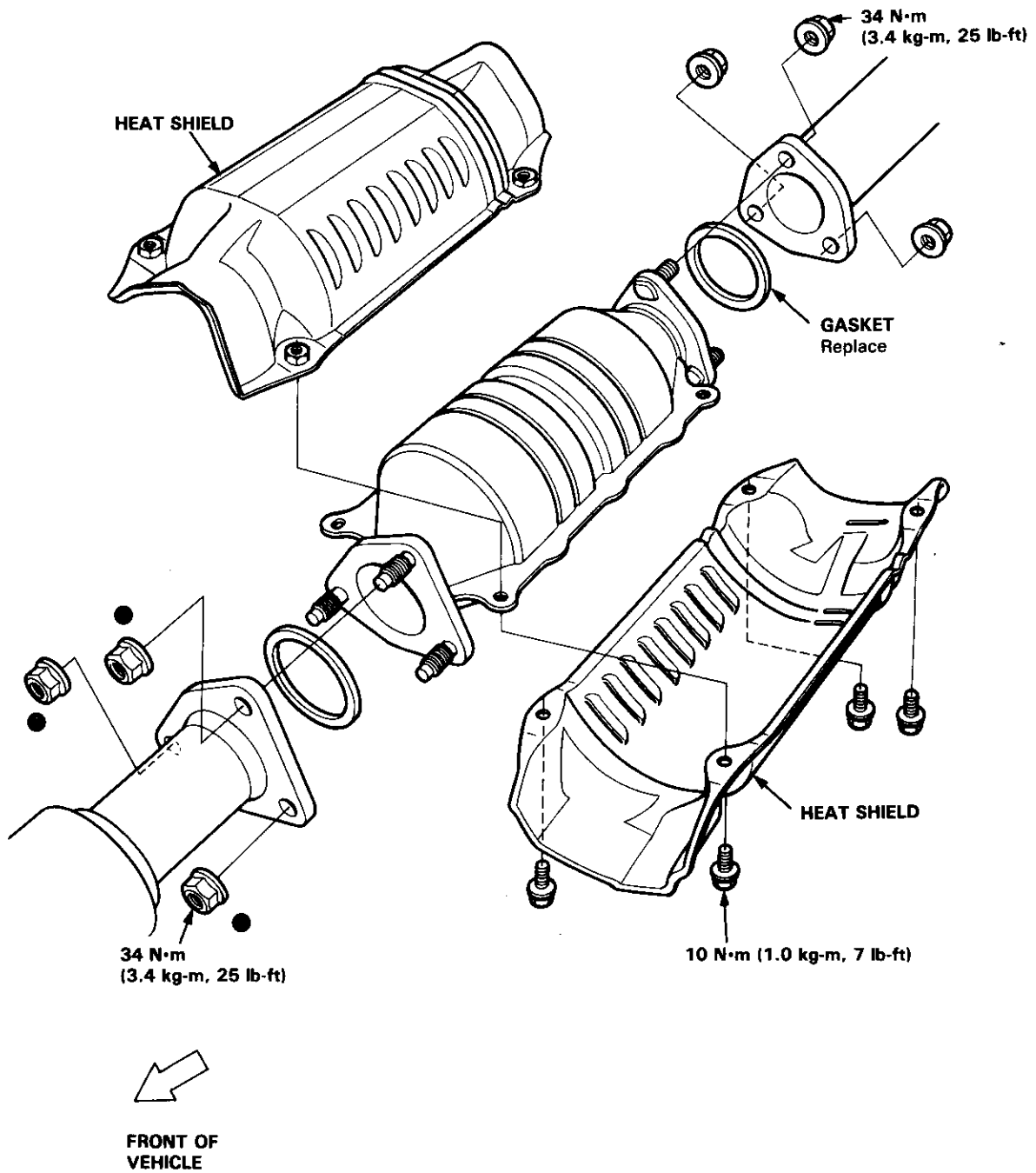



Exhaust Gas Recirculation (EGR) System

Troubleshooting Flowchart

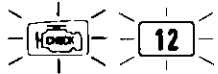

The Malfunction Indicator Lamp (MIL) indicates Diagnostic Trouble Code (DTC) 12: A problem in the Exhaust Gas Recirculation (EGR) system.

The EGR system is designed to reduce oxides of nitrogen emissions (NO_x) by recirculating exhaust gas through the EGR valve and the intake manifold into the combustion chambers. It is composed of the EGR valve, EGR vacuum control valve, EGR control solenoid valve, ECM and various sensors.

The ECM memory contains ideal EGR valve lifts for varying operating conditions. The EGR valve lift sensor detects the amount of EGR valve lift and sends the information to the ECM. The ECM then compares it with the ideal EGR valve lift which is determined by signals sent from the other sensors. If there is any difference between the two, the ECM varies current to the EGR control solenoid valve to further regulate vacuum applied to the EGR valve.

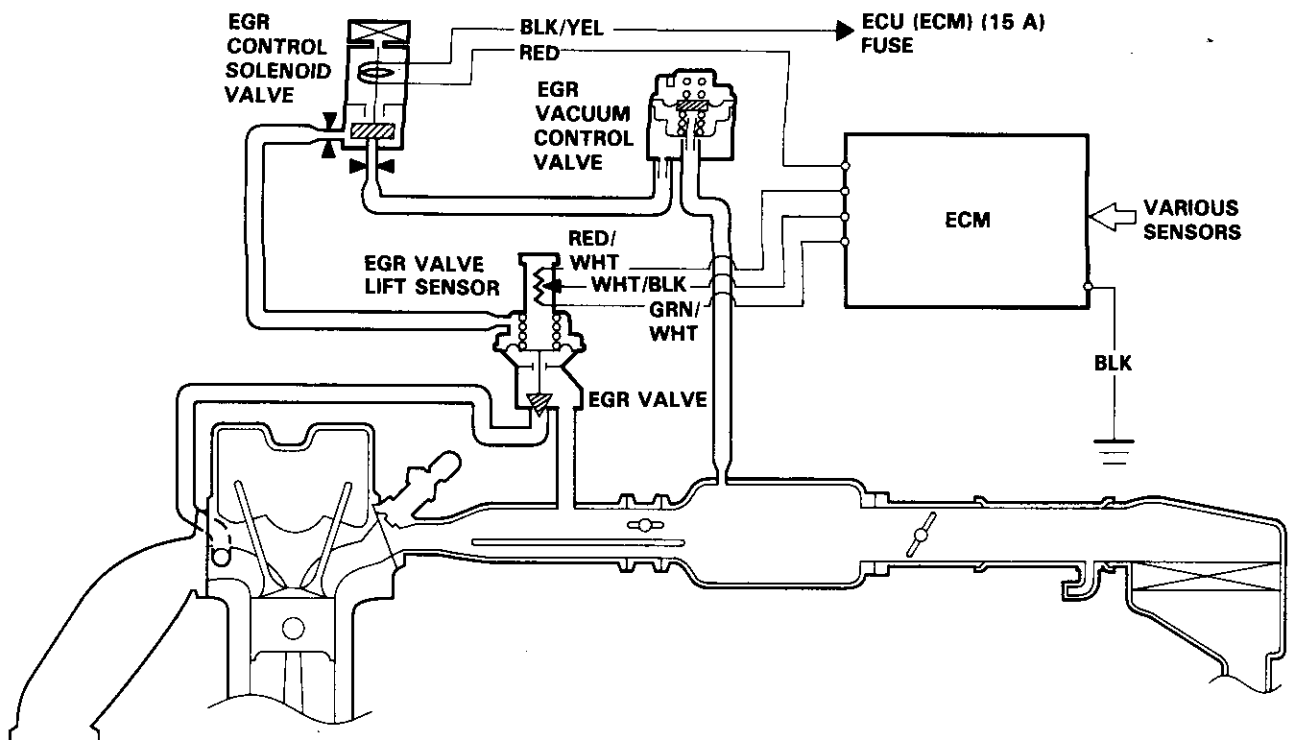

(cont'd)

Emission Control System

Exhaust Gas Recirculation (EGR) System (cont'd)

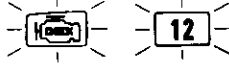

- The MIL has been reported on.
- With service check connector jumped (see page 11-42), code 12 is indicated.

Do the ECM Reset Procedure (see page 11-43).

Road test necessary: Warm up the engine to normal operating temperature (the radiator fan comes on). Drive the car on the road for approx. 10 minutes. Keep the engine speed in the 1,700-2,500 rpm.

Is the MIL on and does it indicate code 12?

NO

YES

With the engine at idle, disconnect the # 16 hose from the EGR valve and connect a vacuum pump/gauge to the hose.

Is there any vacuum?

YES

NO

Move the vacuum pump/gauge to the EGR valve.

Intermittent failure, system is OK at this time. Check for poor connections or loose wires at C425, C426 (located at right shock tower), C463 (located at left side under dash), C117 (EGR valve lift sensor), C310 (EGR control solenoid valve) and ECM.

VACUUM PUMP/
GAUGE
A973X-041-XXXXX

16 HOSE

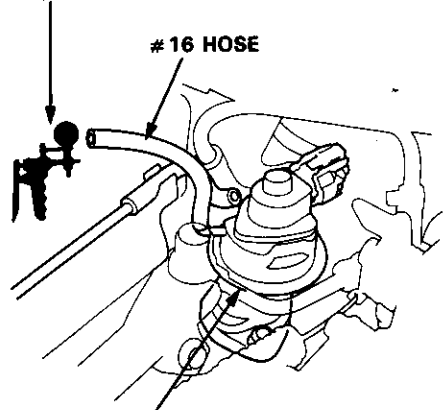

EGR VALVE

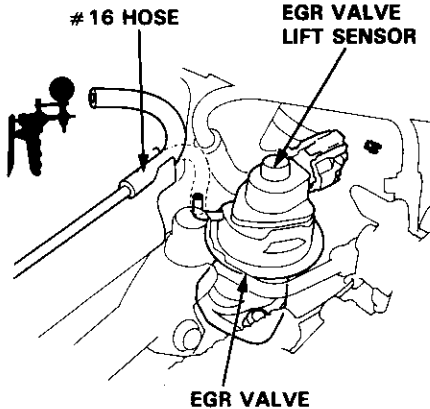

(To page 11-155)

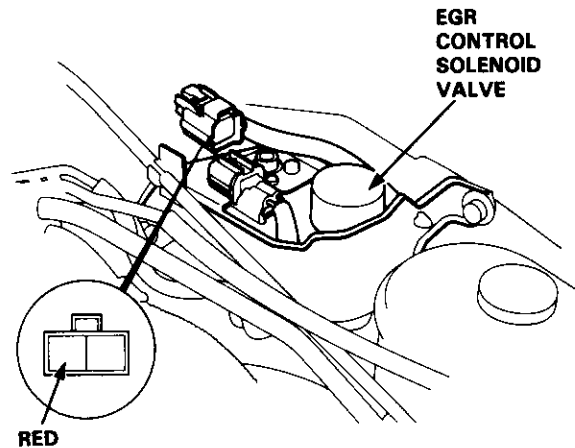

RED

(To page 11-155)



(From page 11-154)

With the engine at idle, apply 200 mm Hg (8 in Hg) of vacuum to the EGR valve.

Does the engine stall or run rough and does the EGR valve hold vacuum?

YES

Disconnect the 2P connector from the EGR control solenoid valve.

Measure voltage between BLK/YEL (+) terminal on the main wire harness and body ground.

Is there battery voltage?

YES

Reconnect the vacuum pump/gauge to the #16 hose.

Start the engine and allow it to idle.

(To page 11-156)

(From page 11-154)

Is there any vacuum?

NO

Turn the ignition switch OFF and disconnect the "A" connector from the ECM.

Check for continuity to ground on RED wire of the 2P connector.

Is there continuity?

NO

Substitute a known-good ECM and retest. If symptom/indication goes away, replace the original ECM.

YES

Check vacuum hose routing of the entire EGR system. If hose routing is OK, replace EGR control solenoid valve.

YES

Repair short in RED control solenoid valve and ECM (A11).

NO

Replace the EGR valve.

NO

Repair open in BLK/YEL wire between the EGR control solenoid valve and ECU (ECM) (15 A) fuse (in the under-dash fuse/relay box).

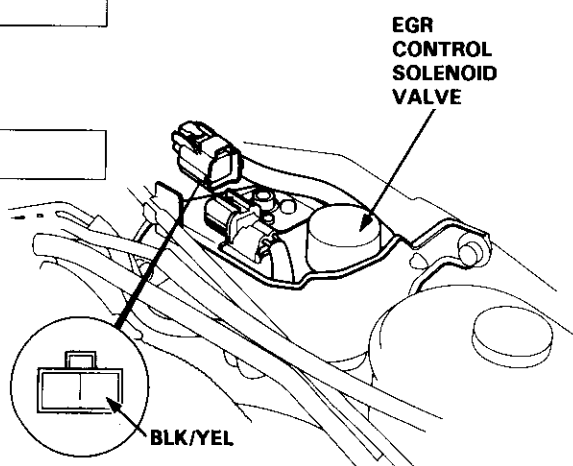

(cont'd)

Emission Control System

Exhaust Gas Recirculation (EGR) System (cont'd)

(From page 11-155)

Connect battery power terminal to the A terminal of the 2P connector. While watching the vacuum gauge, ground the B terminal.

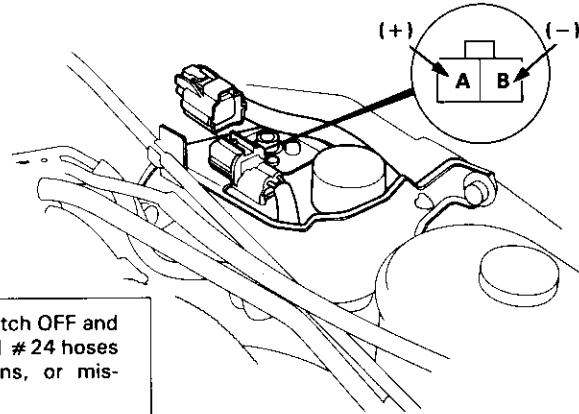

Is there approx. 200 mm Hg (8 in.Hg) within 1 second?

NO

Turn the ignition switch OFF and inspect the # 16 and # 24 hoses for leaks, restrictions, or misrouting.

YES

Turn the ignition switch OFF and reconnect the 2P connector.

Are the hoses OK?

NO

Correct as necessary.

YES

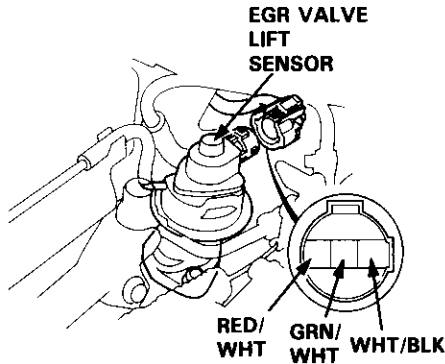

EGR VACUUM CONTROL VALVE
EGR CONTROL SOLENOID VALVE

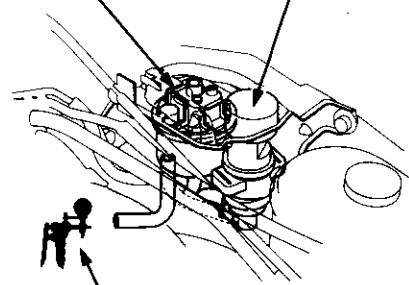

VACUUM PUMP/
GAUGE
A973X-041-XXXXX

Disconnect the lower hose on EGR control solenoid valve and connect a vacuum gauge to the hose.

Disconnect 3P connector from the EGR valve lift sensor.

Start the engine and allow it to idle.

Turn the ignition switch ON.

Is there 150-250 mm Hg (6-10 in.Hg) of vacuum?

NO

Replace the EGR vacuum control valve.

YES

Replace the EGR control solenoid valve.

Measure voltage between RED/WHT (+) terminal and GRN/WHT (-) terminal.

Is there approx. 5 V?

NO

Measure voltage between RED/WHT (+) terminal and body ground.

YES

(To page 11-157)

(To page 11-157)



(From page 11-156)

(From page 11-156)

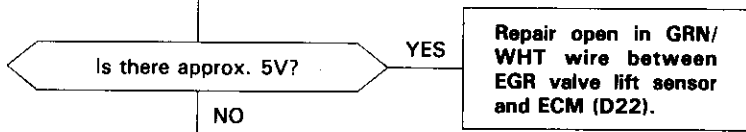

Connect the test harness "D" connector to the ECM only, not to the main wire harness (see page 11-45).

Turn the ignition switch ON.

Measure voltage between D19 (+) terminal and D22 (-) terminal.

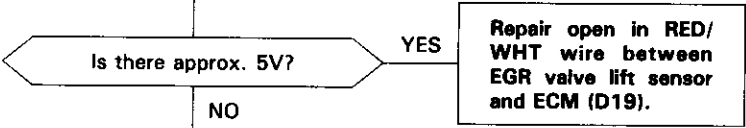

Substitute a known-good ECM and recheck. If symptom/indication goes away, replace the original ECM.

Turn the ignition switch OFF.

Reconnect the 3P connector to the EGR valve lift sensor.

Connect the test harness between the ECM and connectors (see page 11-45).

Turn the ignition switch ON.

Measure voltage between D12 (+) terminal and D22 (-) terminal.

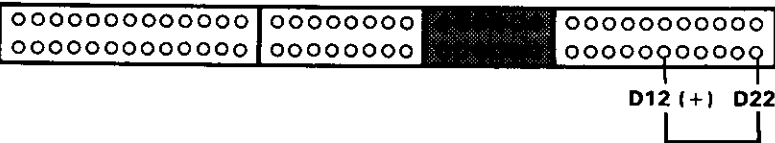
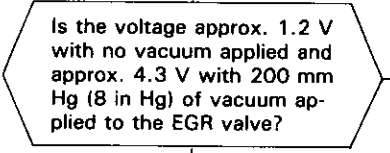

1.2 V with no vacuum applied?
4.3 V with 200 mm Hg (8 in.Hg) of vacuum applied?

NO

- Repair open or short in WHT/BLK wire between EGR valve lift sensor and ECM (D12).
- If wire is OK, replace the EGR valve.

(To page 11-158)

(cont'd)

Emission Control System

Exhaust Gas Recirculation (EGR) System (cont'd)

(From page 11-158)

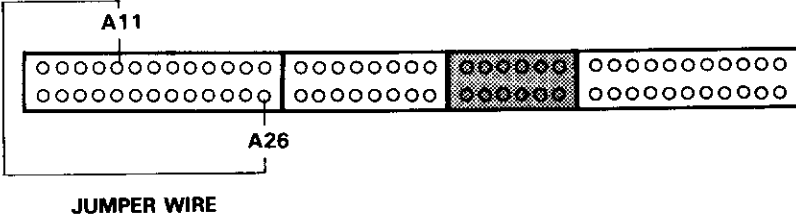
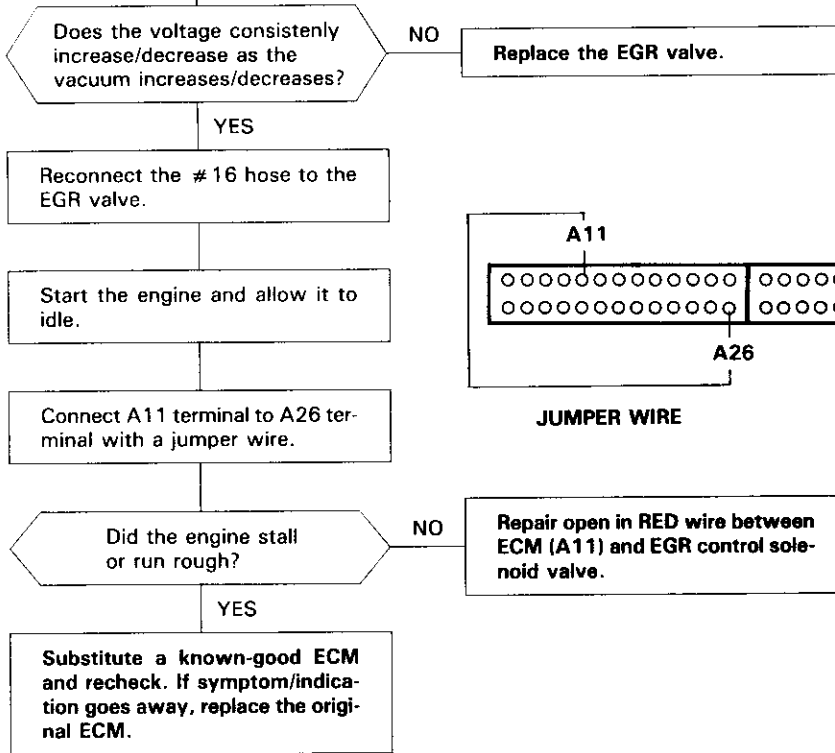



Positive Crankcase Ventilation (PCV) System

Description

The Positive Crankcase Ventilation (PCV) system is designed to prevent blow-by gas from escaping to the atmosphere. The PCV valve contains a spring-loaded plunger. When the engine starts, the plunger in the PCV valve is lifted in proportion to intake manifold vacuum and the blow-by gas is drawn directly into the intake manifold.

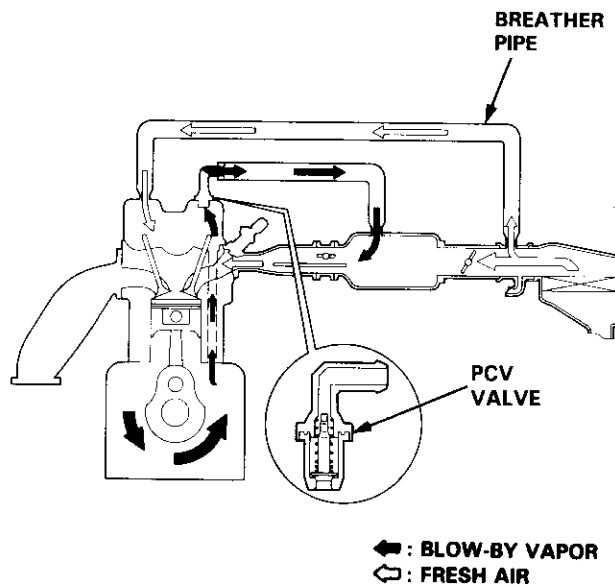

Inspection

1. Check the PCV hoses and connections for leaks and clogging.

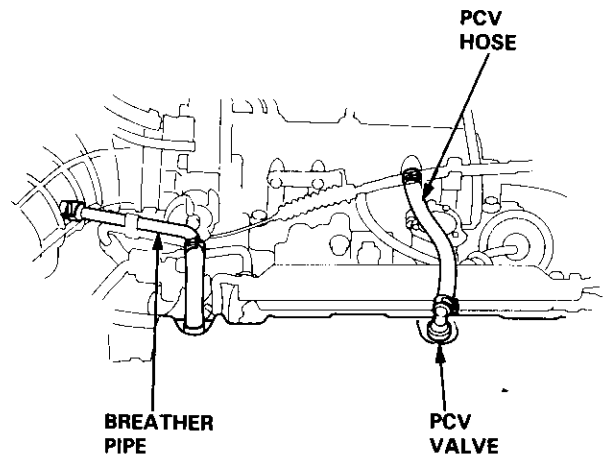

2. At idle, make sure there is a clicking sound from the PCV valve when the hose between PCV valve and intake manifold is lightly pinched with your fingers or pliers.

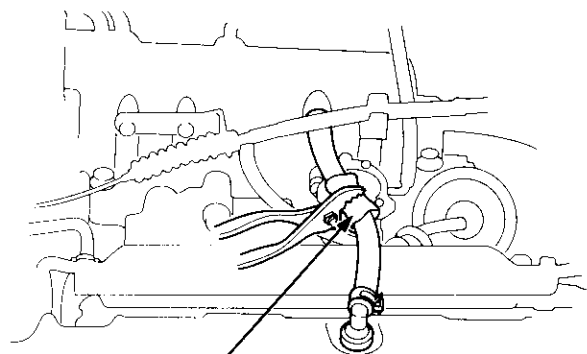

Gently pinch here

- If there is no clicking sound, check the PCV valve grommet for cracks or damage. If the grommet is OK, replace the PCV valve and recheck.

Emission Control System

Evaporative Emission (EVAP) Controls

Description

The evaporative emission controls are designed to minimize the amount of fuel vapor escaping to the atmosphere. The system consists of the following components:

A. Evaporative Emission (EVAP) Control Canister

An EVAP control canister is used for the temporary storage of fuel vapor until the fuel vapor can be purged from the EVAP control canister into the engine and burned.

B. Vapor Purge Control System

EVAP control canister purging is accomplished by drawing fresh air through the EVAP control canister and into a port on the throttle body. The purging vacuum is controlled by the EVAP purge control diaphragm valve and the EVAP purge control solenoid valve.

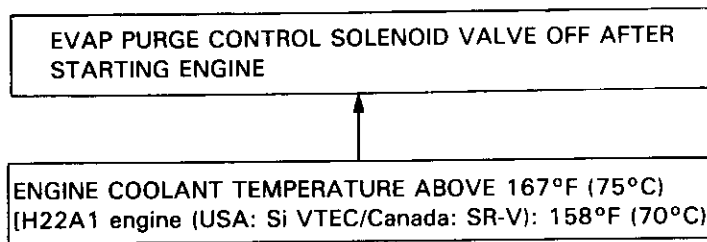

C. Fuel Tank Vapor Control System

When fuel vapor pressure in the fuel tank is higher than the set value of the EVAP two way valve, the valve opens and regulates the flow of fuel vapor to the EVAP control canister.

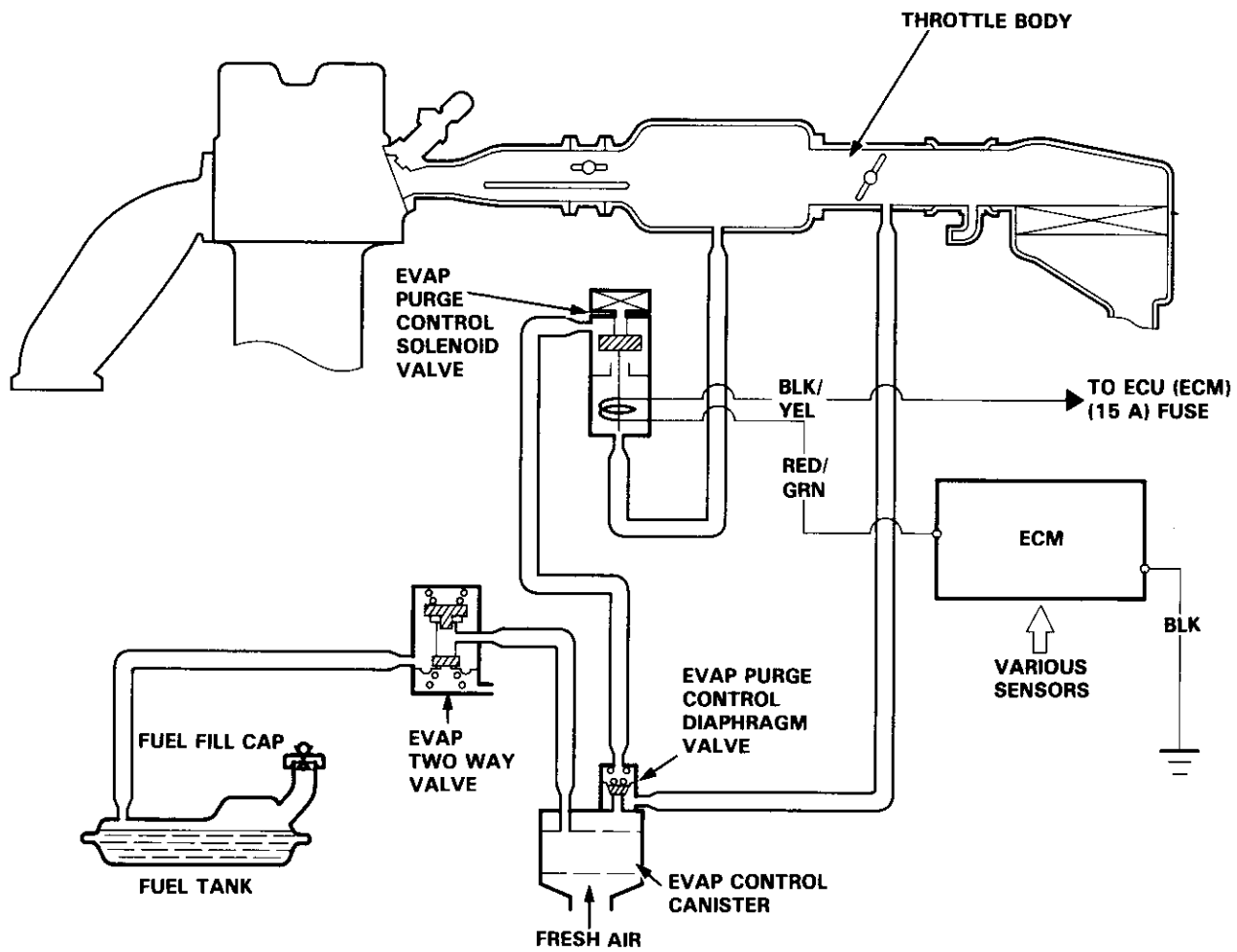

(cont'd)

Emission Control System

Evaporative Emission (EVAP) Controls (cont'd)

Troubleshooting Flowchart

Inspection of Evaporative Emission Controls

Disconnect #3 vacuum hose from the EVAP purge control diaphragm valve (on the EVAP control canister) and connect a vacuum gauge to the hose.

Start the engine and allow it to idle.
NOTE: Engine coolant temperature must be below 158°F (70°C)

EVAP PURGE CONTROL DIAPHRAGM VALVE

#3 VACUUM HOSE

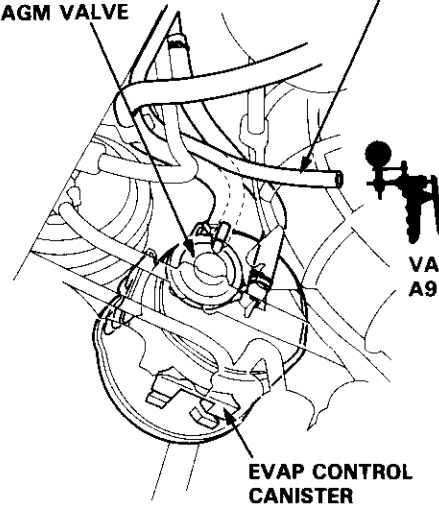

VACUUM PUMP/GAUGE
A973X-041-XXXXX

Is there vacuum?

YES

NO

Disconnect the 2P connector.

EVAP PURGE CONTROL SOLENOID VALVE

RED/
GRN (-)

BLK/
YEL (+)

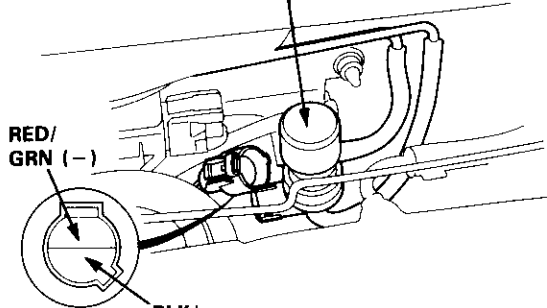

Measure voltage between BLK/YEL (+) terminal and RED/GRN (-) terminal.

Is there battery voltage?

YES

NO

Inspect vacuum hose routing.
If OK, replace EVAP purge control solenoid valve.

Measure voltage between BLK/YEL (+) terminal and body ground.

(To page 11-163)

(To page 11-163)

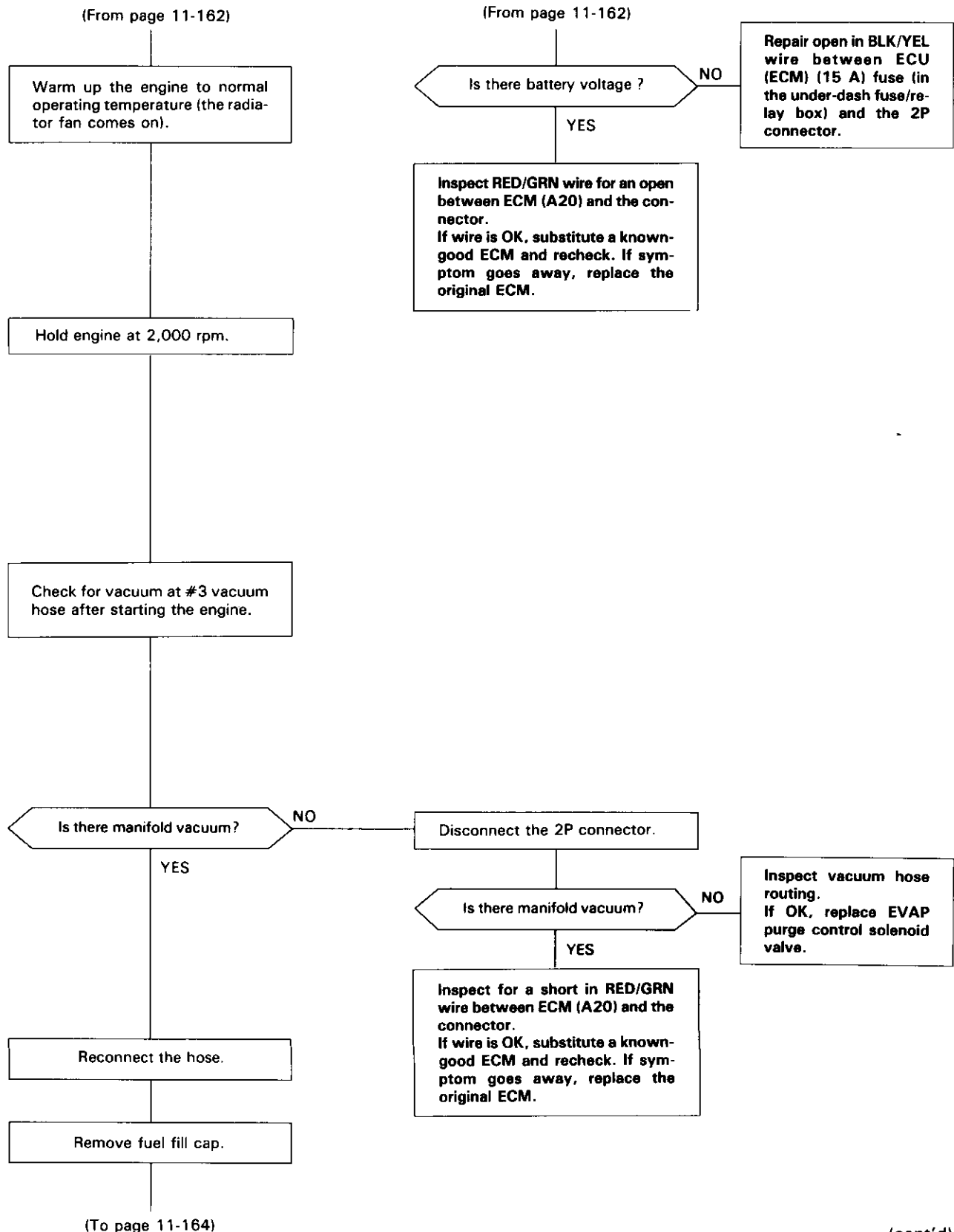

(cont'd)

Emission Control System

Evaporative Emission (EVAP) Controls (cont'd)

(From page 11-163)

Connect a vacuum gauge to EVAP control canister purge air hose.

VACUUM PRESSURE GAUGE 0-4 in. Hg
07JAZ-001000B

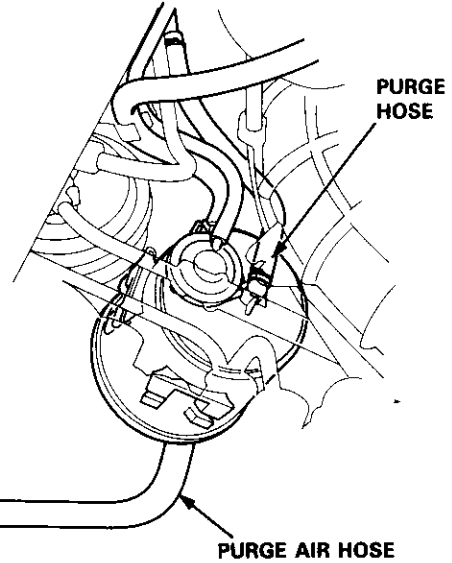
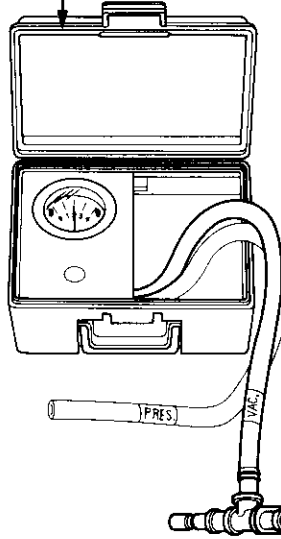

Start the engine and raise speed to 3,500 rpm.

Does vacuum appear on gauge within 1 minute? NO

YES

See EVAP two way valve test to complete. Evaporative emission controls are OK.

Connect a vacuum gauge to the purge hose and raise the engine speed to 3,500 rpm.

Does vacuum appear on the gauge? NO

YES

Replace the EVAP control canister.

Inspect the purge hose and throttle body port for pinch or blockage.



EVAP Two Way Valve Test

1. Remove the fuel fill cap.
2. Remove vapor line from the fuel tank and connect to T-fitting from vacuum gauge and vacuum pump as shown.

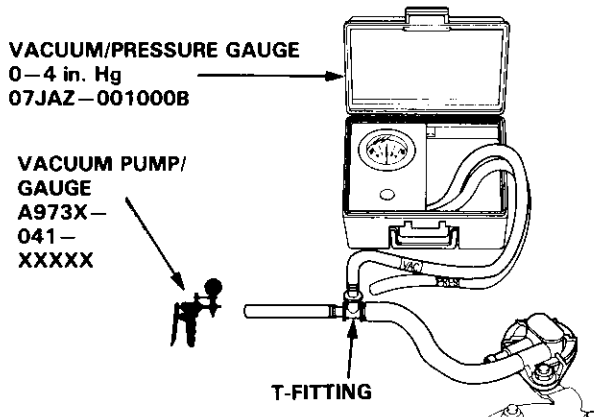

3. Apply vacuum slowly and continuously while watching the gauge.

Vacuum should stabilize momentarily at 5 to 15 mm Hg (0.2 to 0.6 in. Hg).

- If vacuum stabilizes (valve opens) below 5 mm Hg (0.2 in. Hg) or above 15 mm Hg (0.6 in. Hg), install a new valve and retest.

4. Move vacuum pump hose from vacuum to pressure fitting, and move vacuum gauge hose from vacuum to pressure side as shown.

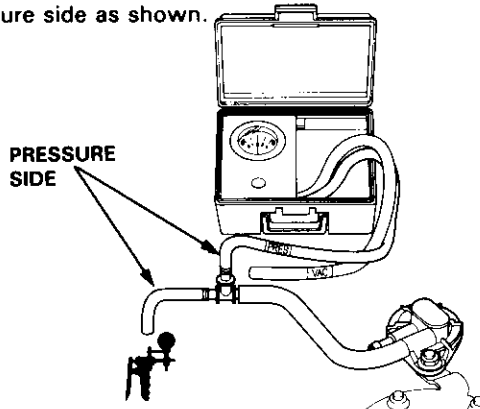

5. Slowly pressurize the vapor line while watching the gauge.

Pressure should stabilize at 10 to 35 mm Hg (0.4 to 1.4 in. Hg).

- If pressure momentarily stabilizes (valve opens) at 10 to 35 mm Hg (0.4 to 1.4 in. Hg), the valve is OK.
- If pressure stabilizes below 10 mm Hg (0.4 in. Hg) or above 35 mm Hg (1.4 in. Hg), install a new valve and retest.

Transaxle

Clutch	12-1
Manual Transmission	13-1
Automatic Transmission	14-1
Differential	
Manual Transmission	15-1
Automatic Transmission	15-10
Driveshafts	16-1



Clutch

Special Tools	12-2
Illustrated Index	12-3
Clutch Pedal	
Adjustment	12-4
Clutch Master Cylinder	
Removal/Installation	12-5
Slave Cylinder	
Removal	12-6
Installation	12-6
Release Bearing	
Disassembly/Inspection	12-7
Installation	12-7
Pressure Plate	
Removal/Inspection	12-8
Clutch Disc	
Inspection	12-9
Flywheel	
Inspection/Removal	12-10
Flywheel and Clutch Disc	
Installation	12-10



Special Tools

Ref. No	Tool Number	Description	Qty	Page Reference
①	07JAF — PM7011A	Clutch Alignment Disc	1	12-8
②	07LAB — PV00100 or 07924 — PD20003	Ring Gear Holder	1	12-8, 9, 10
③	07LAF — PT00110	Clutch Alignment Shaft	1	12-8, 10
④	07936 — 3710100	Handle	1	12-8, 10

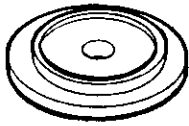

①

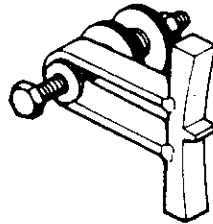

②



③



④

Illustrated Index



NOTE:

- Whenever the transmission is removed, clean and grease the release bearing sliding surface.
- When parts marked "*" are removed, the clutch hydraulic system must be bled.
- Bleed the clutch hydraulic system (see page 12-6).
- Inspect the hoses for damage, leaks, interference, and twisting.

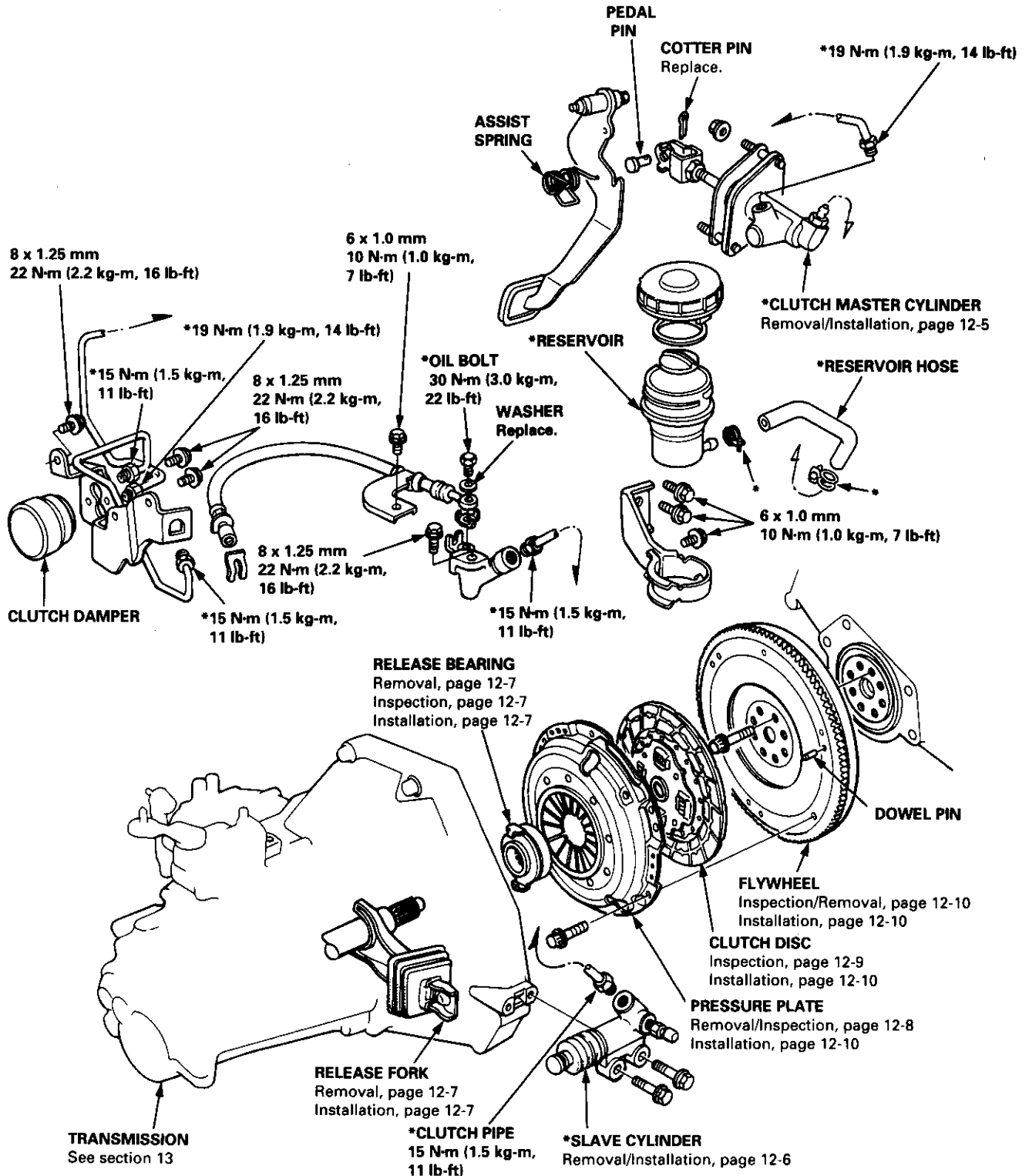

Clutch Pedal

Adjustment

NOTE

- To check the clutch pedal switch A and B, see section 23.
- The clutch is self-adjusting to compensate for wear.

CAUTION: If there is no clearance between the master cylinder piston and push rod, the release bearing is held against the diaphragm spring, which can result in clutch slippage or other clutch problems.

1. Loosen locknut A, and back off the clutch pedal switch A or bolt until it no longer touches the clutch pedal.
2. Loosen locknut C, and turn the push rod in or out to get the specified stroke and height at the clutch pedal.
3. Tighten locknut C.

4. Thread the clutch pedal switch A in until it contacts the clutch pedal.
5. Turn the clutch switch A in 1/4 — 1/2 turn further.
6. Tighten locknut A.
7. Loosen locknut B and clutch pedal switch B.
8. Measure the clearance between the floor board and clutch pedal with the clutch pedal fully depressed.
9. Release the clutch pedal 15 — 20 mm (0.59 — 0.79 in) from the fully depressed position and hold it there. Adjust the position of clutch pedal switch B so that the engine will start with the clutch pedal in this position.
10. Thread the clutch pedal switch B in 1/4 — 1/2 turn further.
11. Tighten locknut B.

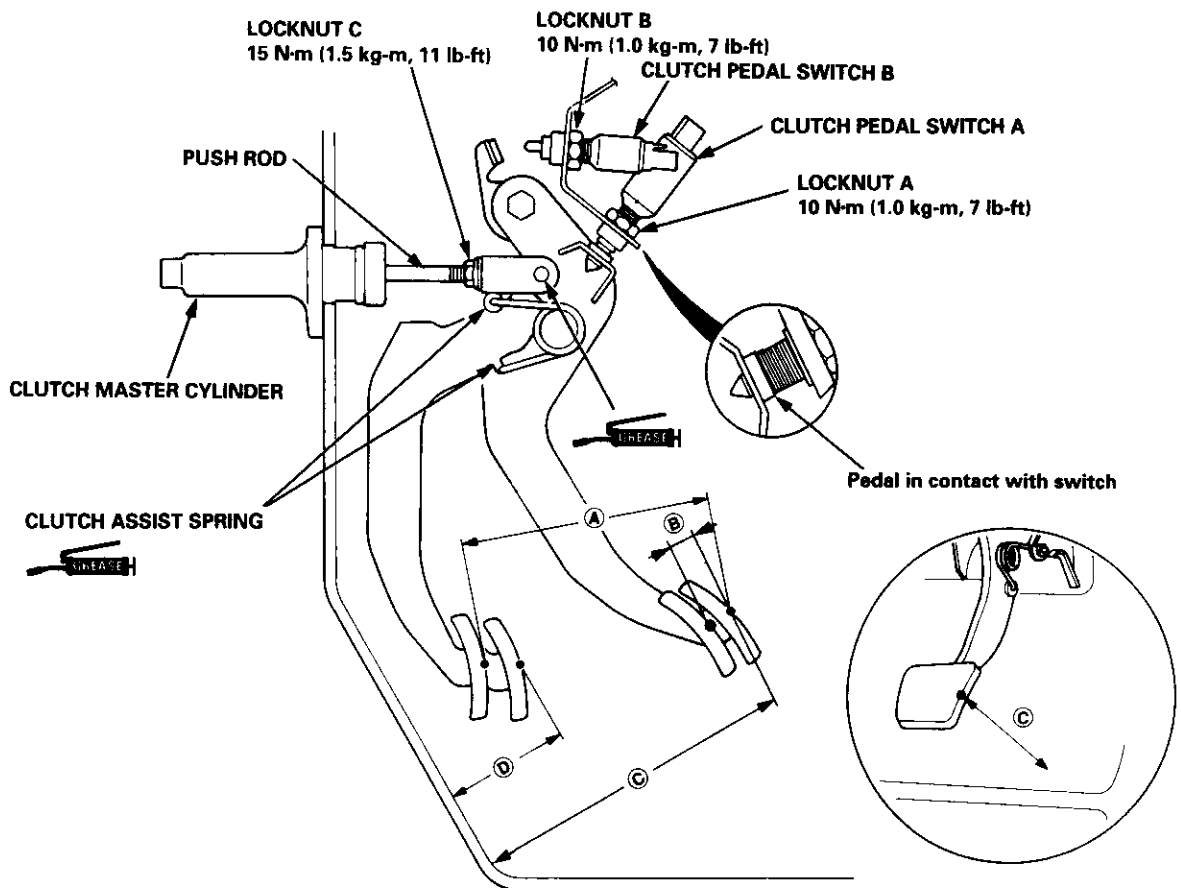

Ⓐ (STROKE at PEDAL): 135 — 145 mm (5.31 — 5.71 in)

Ⓑ (TOTAL CLUTCH PEDAL FREE PLAY): 9.0 — 15.0 mm (0.35 — 0.59 in) include the pedal play 1 — 7 mm (0.04 — 0.28 in).

Ⓒ (CLUTCH PEDAL HEIGHT): 190 mm (7.48 in)

Ⓓ (CLUTCH PEDAL DISENGAGEMENT HEIGHT): 94 mm (3.70 in) minimum to the floor.



Clutch Master Cylinder

Removal/Installation

CAUTION: Avoid spilling brake fluid on painted surfaces, as it may damage the finish.

NOTE: Plug the end of the reservoir hose, and cap the end of the clutch pipe, with a plug and cap such as those discarded from an A/C kit.

1. Remove the reservoir hose from the clutch master cylinder and drain the brake fluid into a suitable container.

NOTE: The brake fluid can be sucked out through the top of the reservoir with a syringe.

2. Remove the reservoir from the engine compartment bulkhead.
3. Disconnect the clutch pipe from the clutch master cylinder.

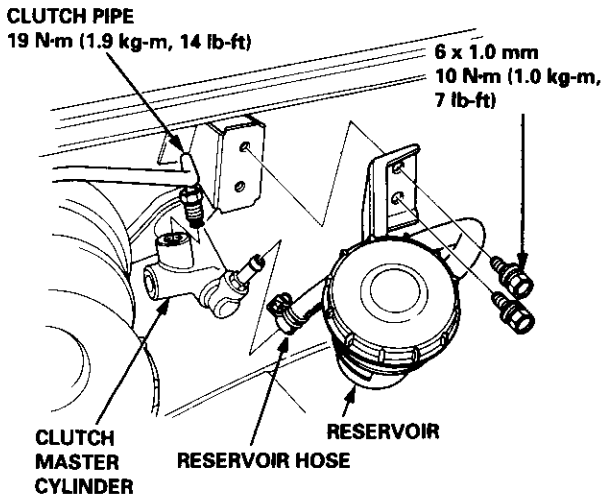

4. Pry out the cotter pin, and pull the pedal pin out of the yoke. Remove the nuts.

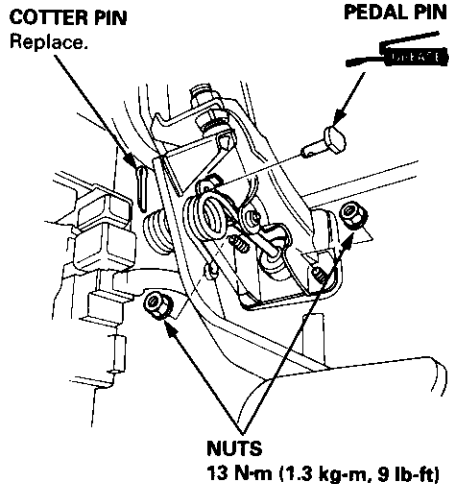

5. Remove the clutch master cylinder.

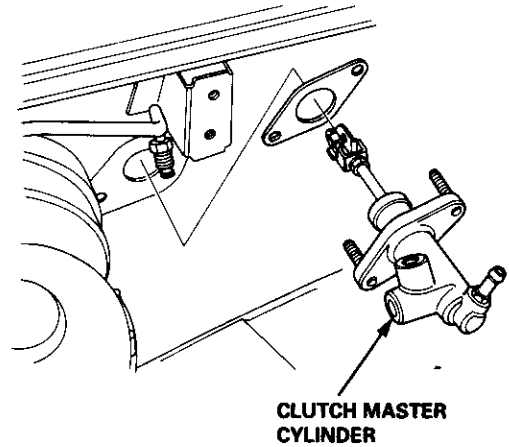

6. Install the clutch master cylinder in the reverse order of removal.

NOTE: Bleed the clutch hydraulic system (see page 12-6).

Slave Cylinder

Removal

1. Disconnect the clutch pipe from the slave cylinder.

CAUTION: Avoid spilling brake fluid on the painted surfaces, as it may damage the finish.

NOTE: Plug the end of the reservoir hose, and cap the end of the clutch pipe, with a plug and cap such as those discarded from an A/C kit.

2. Remove the slave cylinder from the clutch housing.

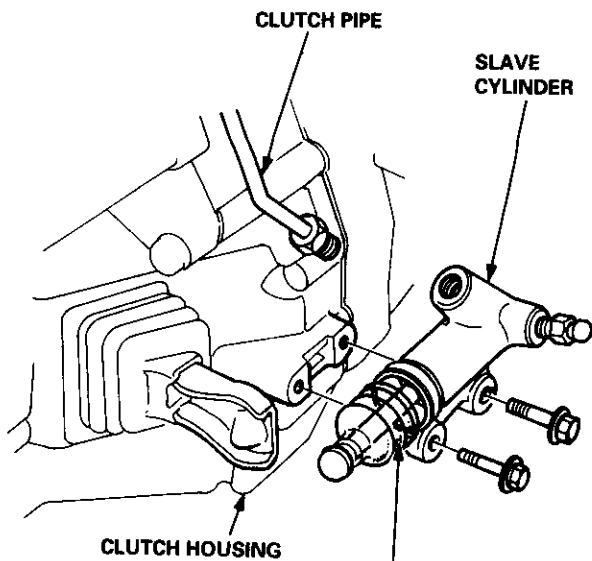

BOOT
Remove and check for signs of leaking and deterioration.

Installation

GREASE H: Super High Temp Urea Grease (P/N 08798 — 9002).

GREASE H: Brake Assembly Lube or equivalent rubber grease.

1. Install the slave cylinder on the clutch housing.
2. Connect the clutch pipe.

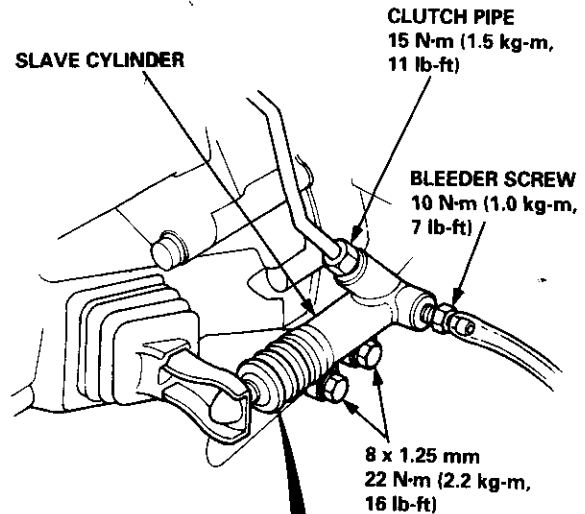

GREASE H
(P/N 08798 — 9002)

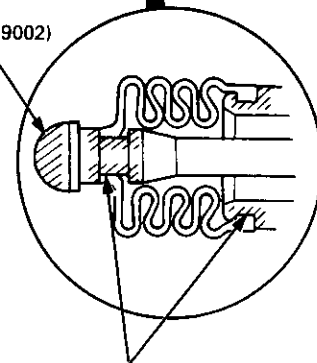

GREASE H
(Brake Assembly Lube)

3. Bleed the clutch hydraulic system:
 - Attach a hose to the bleeder screw and suspend the hose in a container of brake fluid.
 - Make sure there is an adequate supply of fluid at the master cylinder, then slowly pump the clutch pedal until no more bubbles appear at the bleeder hose.
 - Refill the master cylinder fluid when done.
 - Use only DOT 3 or 4 brake fluid.



Release Bearing

Disassembly/Inspection

- 1 Remove the boot from the clutch housing.
- 2 Remove the release fork from the clutch housing by squeezing the release fork set spring with pliers. Remove the release bearing.

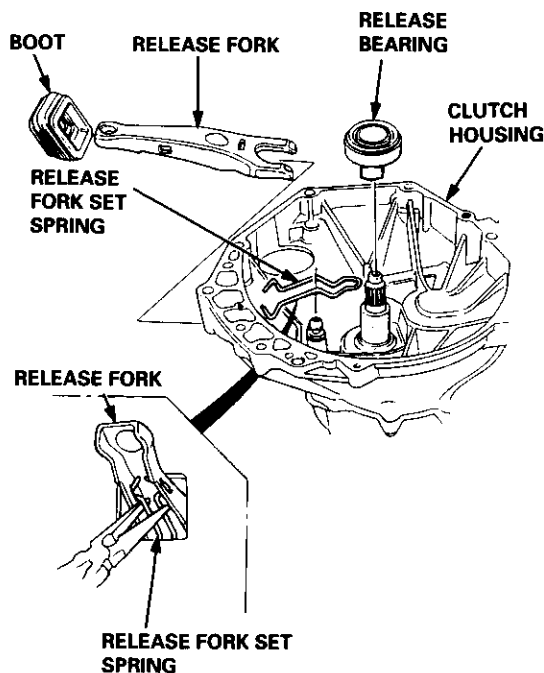

- 3 Check the release bearing for play by spinning it by hand.

CAUTION: The release bearing is packed with grease. Do not wash it in solvent.

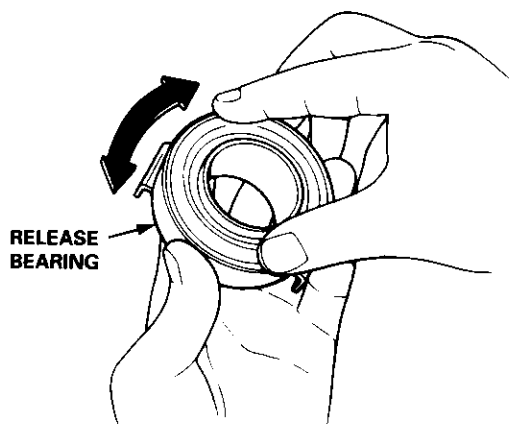

- 4 If there is excessive play, replace the release bearing with a new one.

Installation

NOTE: Use only Super High Temp Urea Grease (P/N 08798 — 9002).

- 1 Install the release fork set spring on the release fork.

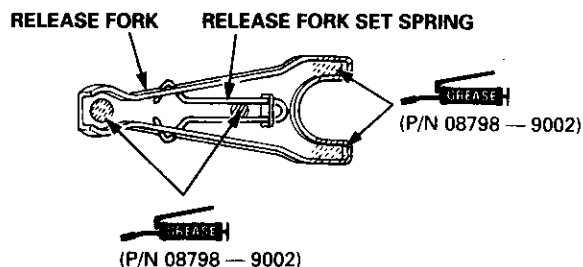

- 2 With the release fork slid between the release bearing pawls, install the release bearing on the mainshaft while inserting the release fork through the hole in clutch housing.
- 3 Align the detent of the release fork with the release fork bolt, then press the release fork over the release fork bolt squarely.

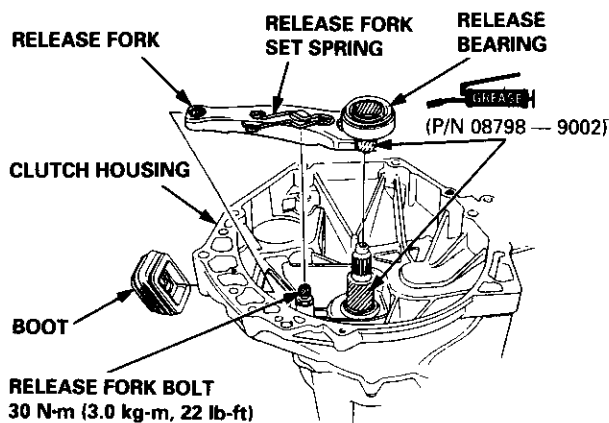

- 4 Install the boot, being sure that there is no clearance: release fork-to-boot, and boot-to-clutch housing.
- 5 Move the release fork right and left to make sure that the release fork fits properly against the release bearing, and that the release bearing slides smoothly.

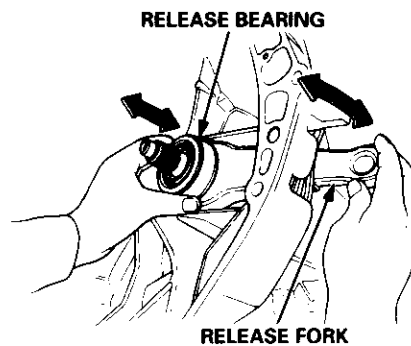

Pressure Plate

Removal/Inspection

1. Inspect the fingers of the diaphragm spring for wear at the release bearing contact area.
2. Assemble the special tools as shown.

NOTE: Assemble the Clutch Alignment Disc with side "A" facing the diaphragm spring as shown.

3. Check the diaphragm spring fingers for height using the special tools and a feeler gauge.

Standard (New): 0.6 mm (0.02 in) max.

Service Limit: 0.8 mm (0.03 in)

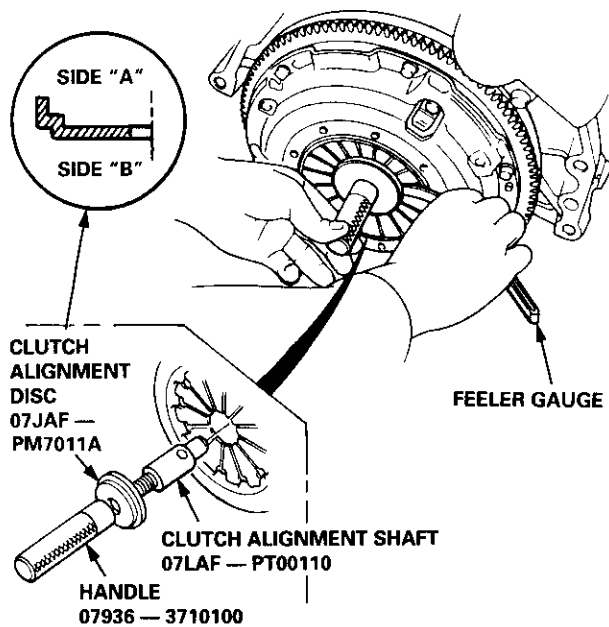

4. Install the special tools as shown.

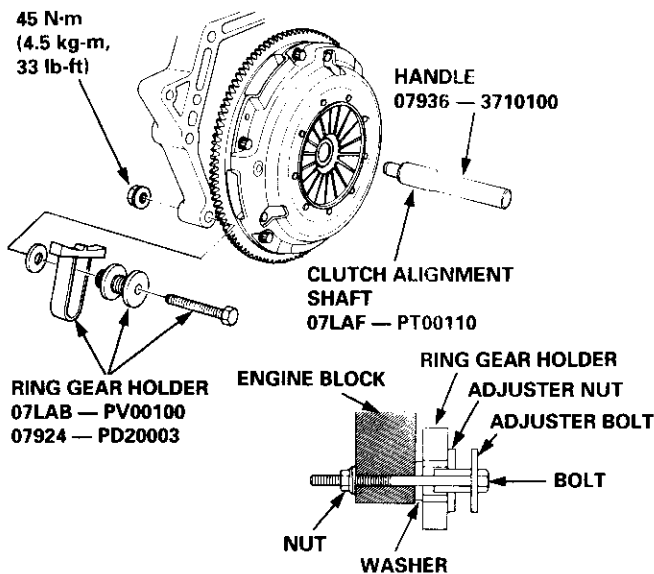

5. To prevent warping, unscrew the pressure plate mounting bolts in a crisscross pattern in several steps, then remove the pressure plate.

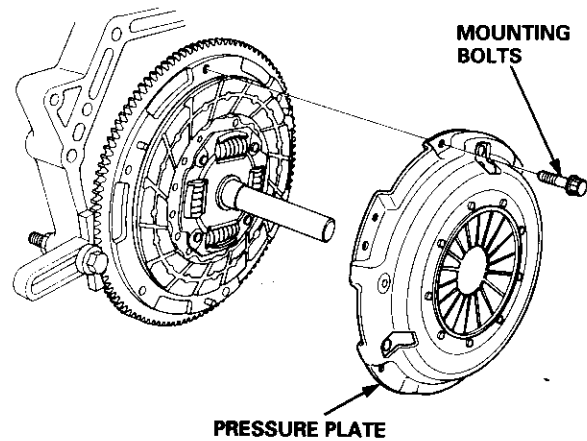

6. Inspect the pressure plate surface for wear, cracks, and burning.
7. Inspect for warpage using a straight edge and a feeler gauge.

NOTE: Measure across the pressure plate at three points.

Standard (New): 0.03 mm (0.001 in) max.

Service Limit: 0.15 mm (0.006 in)

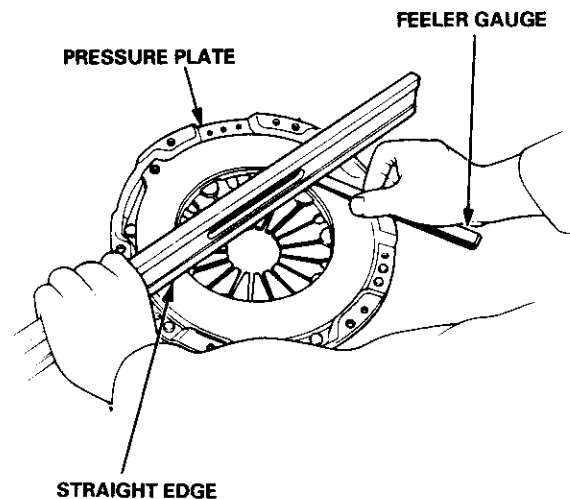



Clutch Disc

Inspection

1. Remove the clutch disc.
2. Inspect the lining of the clutch disc for signs of slipping or oil. Replace it if it is burned black or oil soaked.

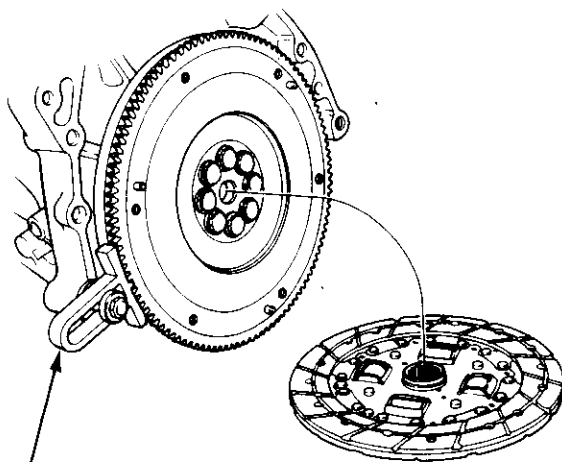

RING GEAR HOLDER
07LAB — PV00100 or
07924 — PD20003

CLUTCH DISC

3. Measure the clutch disc thickness.

Clutch Disc Thickness.

Standard (New): 8.4 — 9.1 mm (0.33 — 0.36 in)
Service Limit: 6.0 mm (0.24 in)

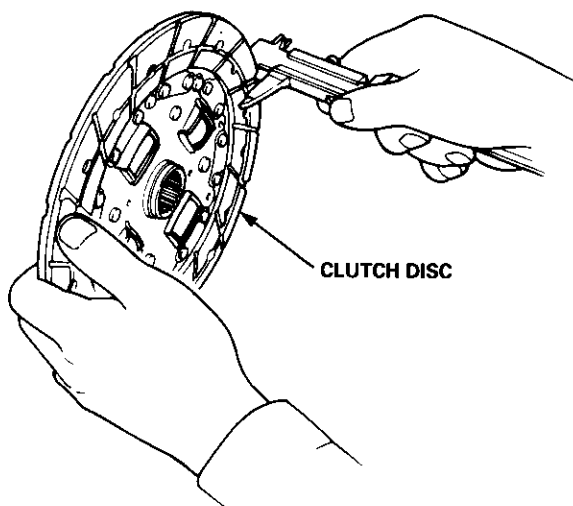

CLUTCH DISC

4. Measure the depth from the lining surface to the rivets, on both sides.

Rivet Depth:

Standard (New): 1.3 mm (0.05 in) min.

Service Limit: 0.2 mm (0.01 in)

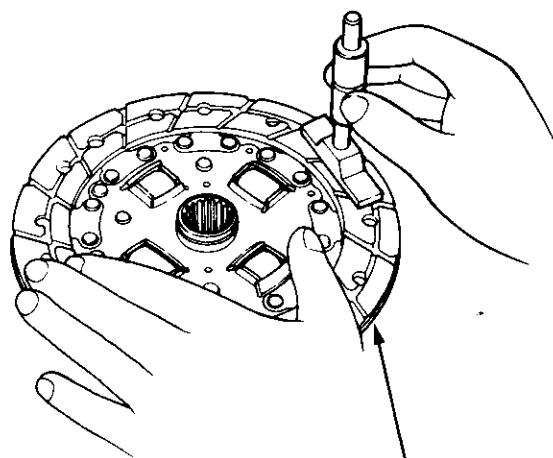

CLUTCH DISC

Flywheel

Inspection/Removal

1. Inspect the ring gear teeth for wear and damage.
2. Inspect the clutch disc mating surface on the flywheel for wear, cracks, and burning.
3. Measure the flywheel runout using a dial indicator through at least two full turns. Push the flywheel towards the engine to take up the crankshaft thrust washer clearance.

NOTE: The runout can be measured with engine installed.

Standard (New): 0.05 mm (0.002 in) max.

Service Limit: 0.15 mm (0.006 in)

If the runout exceeds the service limit, replace the flywheel.

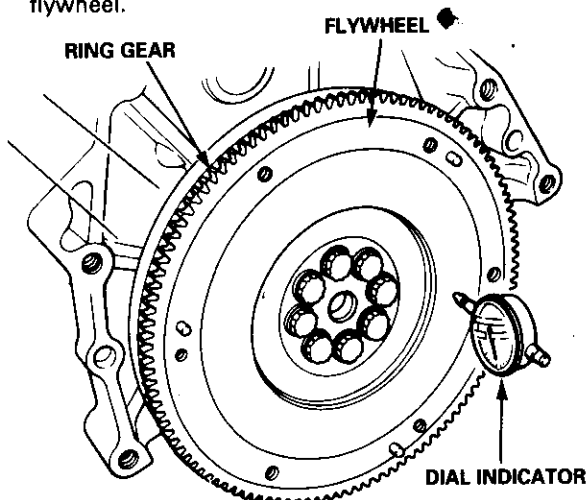

4. Remove the eight flywheel mounting bolts in a crisscross pattern in several steps, and remove the flywheel.

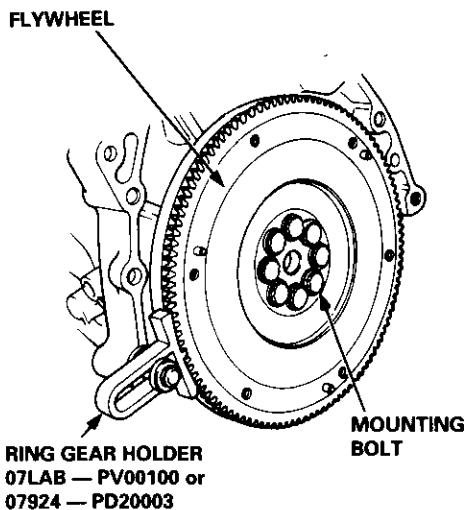

Flywheel and Clutch Disc

Installation

1. Align the hole in the flywheel with the crankshaft dowel pin and assemble. Install the mounting bolts only finger tight.
2. Install the special tool, then torque the mounting bolts in a crisscross pattern in several steps as shown.

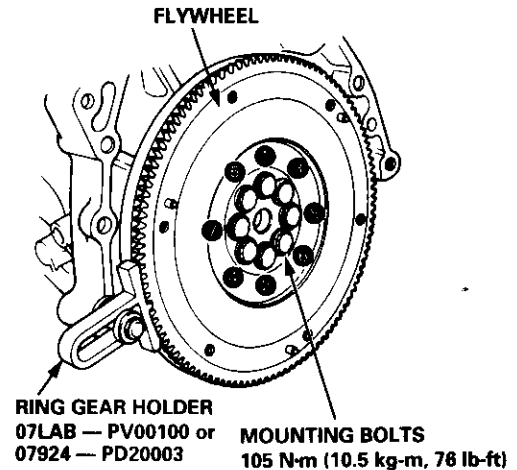

3. Install the clutch disc using the special tools as shown.

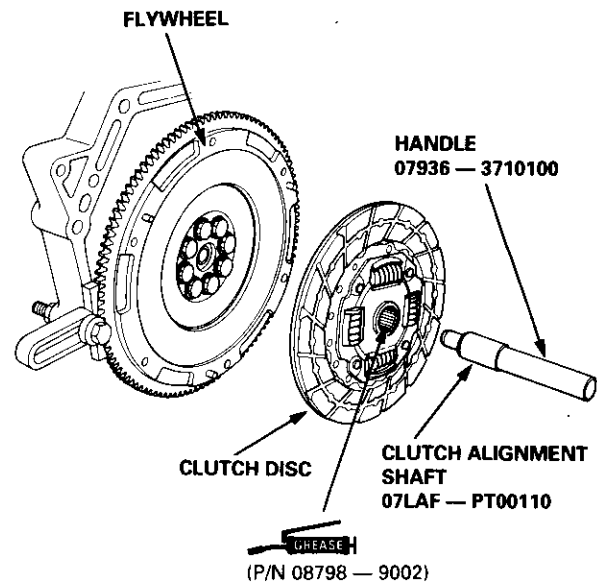



4. Install the pressure plate.

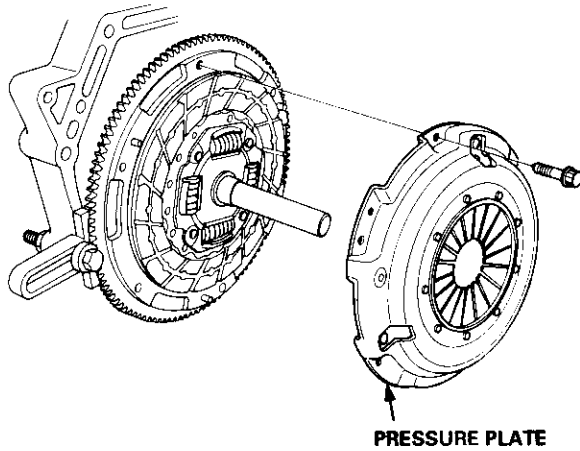

5. Torque the mounting bolts in a crisscross pattern as shown. Tighten them several steps to prevent warping the diaphragm spring.

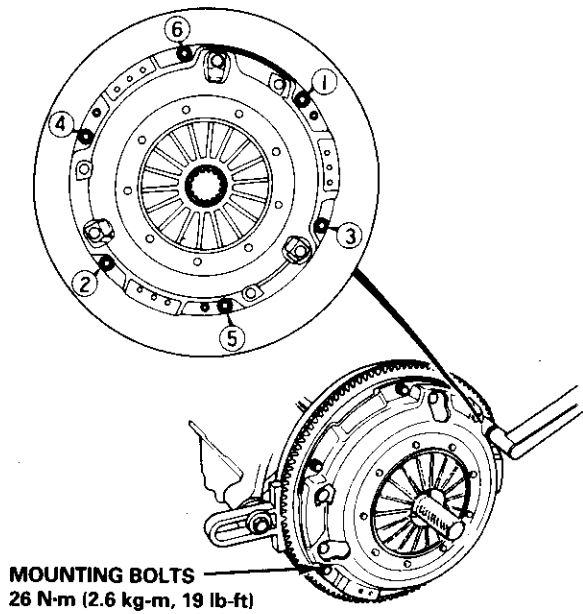

6. Remove the special tools.

Manual Transmission

Special Tools	13-2	Countershaft	
Maintenance		Index	13-23
Transmission Oil	13-3	Clearance Inspection	13-24
Back-up Light Switch		Disassembly	13-25
Replacement	13-3	Inspection	13-26
Transmission Assembly		Reassembly	13-26
Removal	13-4	Shift Fork Assembly	
Gearshift Mechanism		Disassembly/Reassembly	13-28
Overhaul	13-9	Clearance Inspection	13-29
Illustrated Index	13-10	Synchro Sleeve, Synchro Hub	
Shift Arm Assembly		Inspection	13-30
Index	13-12	Installation	13-30
Disassembly/Reassembly	13-13	Synchro Ring, Gear	
Transmission Housing		Inspection	13-31
Removal	13-15	Mainshaft Bearing/Oil Seal	
Reverse Shift Fork		Replacement	13-32
Clearance Inspection	13-16	Countershaft Bearing	
Reverse Idler Gear		Replacement	13-33
Removal	13-17	Mainshaft Thrust Shim	
Mainshaft, Countershaft		Adjustment	13-34
Removal	13-17	Transmission	
Mainshaft		Reassembly	13-37
Index	13-18	Transmission Assembly	
Clearance Inspection	13-19	Installation	13-40
Disassembly	13-20		
Inspection	13-21		
Reassembly	13-22		

NOTE: The radio may have a coded theft protection circuit. Be sure to get the customer's code number before

- Disconnecting the battery.
- Removing the No. 43 (10 A) fuse in the under-hood fuse/relay box.
- Removing the radio.

After service, reconnect power to the radio and turn it on.

When the word "CODE" is displayed, enter the customer's 5-digit code to restore radio operation.



Special Tools

Ref. No.	Tool Number	Description	Q'ty	Page Reference
①	07GAJ — PG20110	Mainshaft Holder	1	13-36, 37
②	07GAJ — PG20130	Mainshaft Base	1	13-36
③	*07736 — A01000A	Adjustable Bearing Puller, 25 — 40 mm	1	13-32, 33
④	07746 — 0010300	Attachment, 42 x 47 mm	1	13-22, 27, 32
⑤	07746 — 0010500	Attachment, 62 x 68 mm	1	13-32, 33
⑥	07746 — 0030100	Driver, 40 mm I.D.	1	13-22
⑦	07746 — 0030400	Attachment 35 mm I.D.	1	13-22
⑧	07749 — 0010000	Driver	1	13-22, 27, 32, 33
⑨	07947 — 6890100	Seal Driver	1	13-27

* Must be used with commercially available 3/8 in x 16 thread/in Slide Hammer.

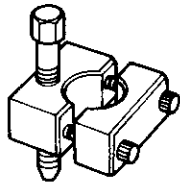

①

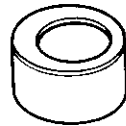

②

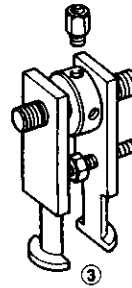

③

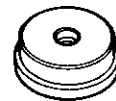

④

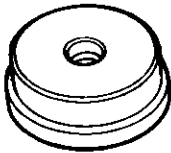

⑤

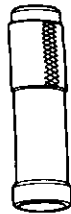

⑥



⑦



⑧

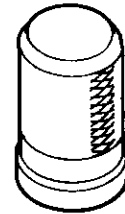

⑨

Transmission Assembly

Removal

⚠ WARNING

- Make sure jacks and safety stands are placed properly, and hoist brackets are attached to correct position on the engine.
- Apply parking brake and block rear wheels so car will not roll off stands and fall on you while working under it.

CAUTION: Use fender covers to avoid damaging painted surfaces.

NOTE: The radio may have a coded theft protection circuit. Be sure to get the customer's code number before

- Disconnecting the battery.
- Removing the No. 43 (10 A) fuse. (Under-hood fuse/relay box)
- Removing the radio.

After service, reconnect power to the radio and turn it on.

When the word "CODE" is displayed, enter the customer's 5-digit code to restore radio operation.

1. Disconnect the negative (-) and positive (+) cables from the battery, then remove the battery.
2. Drain the transmission oil (see page 13-3).
3. Remove the battery base and base stay.

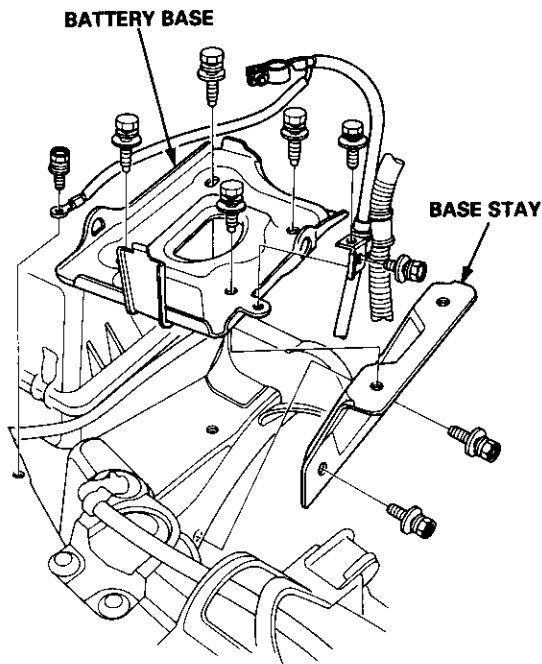

4. Remove the intake air duct and air cleaner assembly.

AIR CLEANER ASSEMBLY

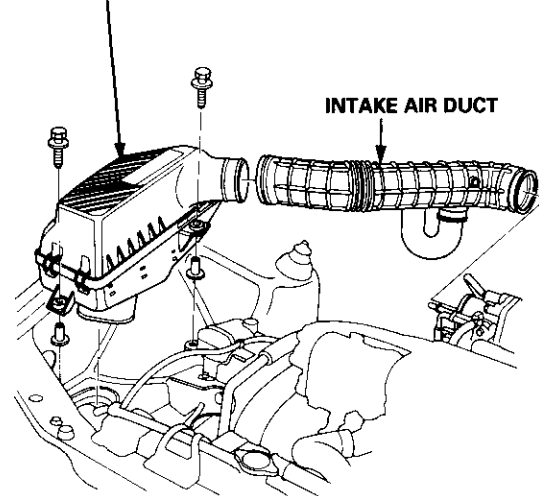

5. Remove the intake control vacuum tank and bracket.

NOTE: Do not disconnect the hoses.

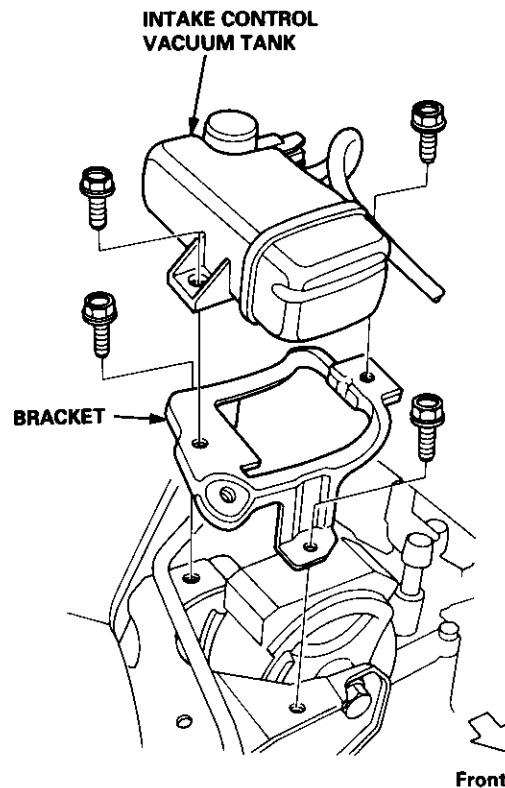



6. Disconnect the starter motor cables, then remove the starter motor.
7. Disconnect the back-up light switch connectors and transmission ground cable.
8. Remove the wire harness clamp.

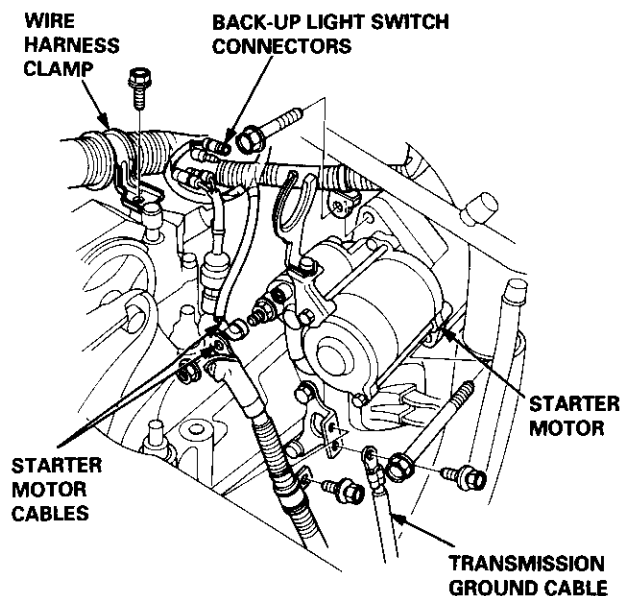

9. Shift the transmission into reverse.
10. First remove the cable bracket, then disconnect the cables from the top housing of the transmission.

NOTE: Remove both cables and the bracket together.

CAUTION: Take care not to bend the cables.

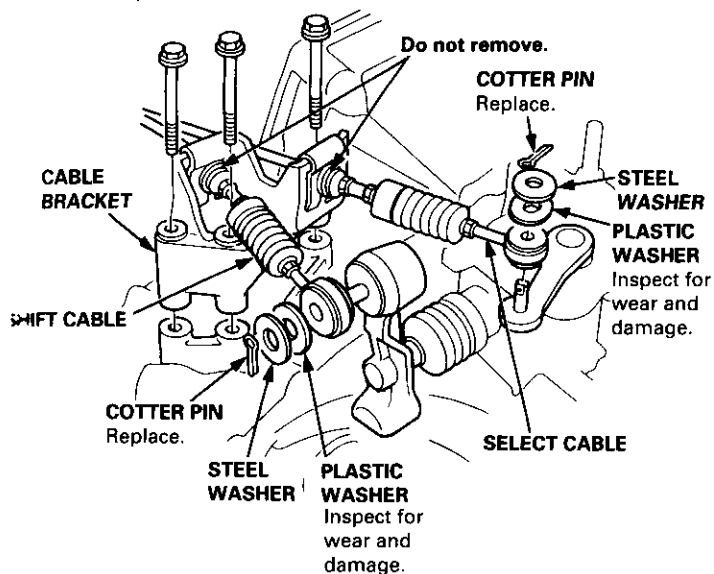

11. Disconnect the vehicle speed sensor (VSS) connector and remove the VSS/power steering speed sensor, but leave its hoses connected.

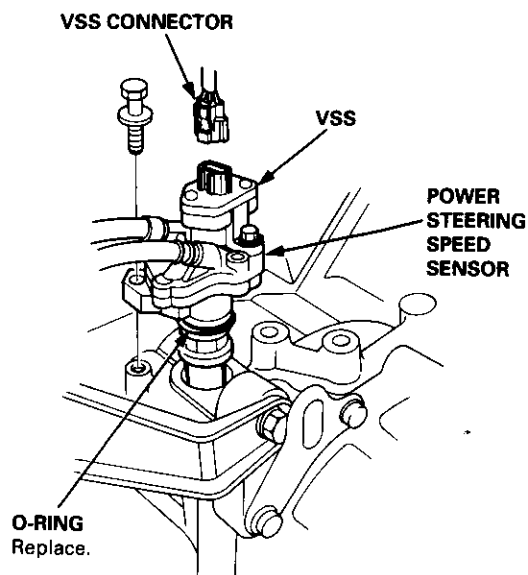

12. Remove the slave cylinder.

NOTE:

- Do not operate the clutch pedal once the slave cylinder has been removed.
- Take care not to bend the clutch pipe.

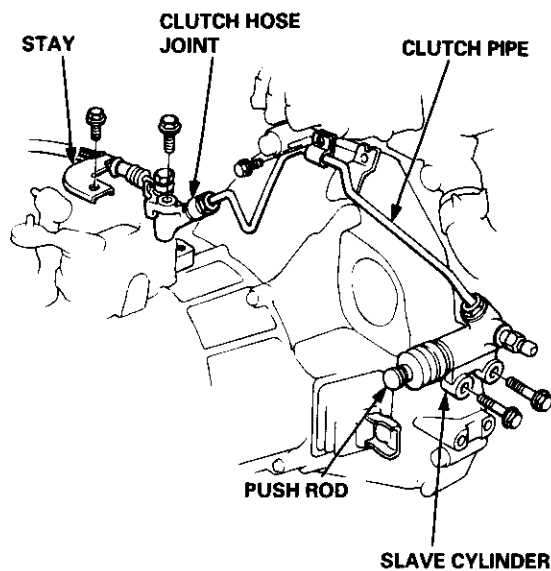

(cont'd)

Transmission Assembly

Removal (cont'd)

13. Remove the clutch damper mounting bolts, and raise the clutch damper.

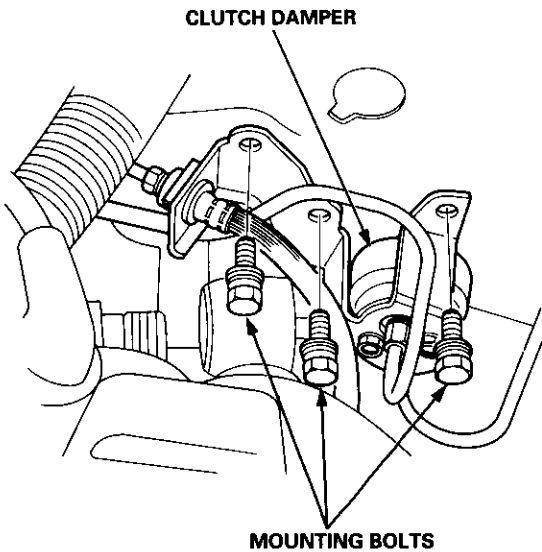

14. Remove the rear engine mount bracket stay.

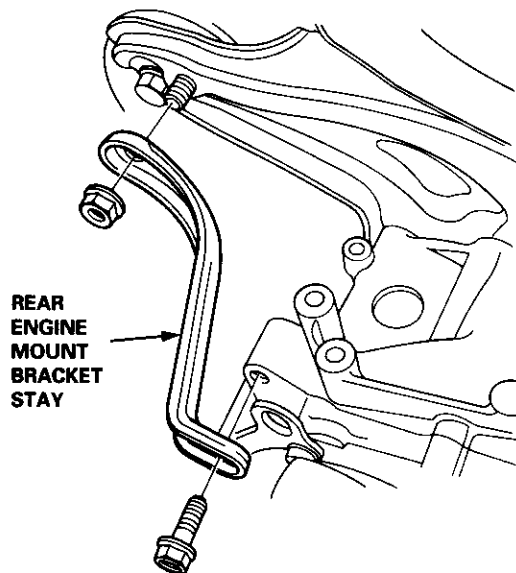

15. Remove the cotter pins and ball joint nuts, then separate the ball joints and lower arms on both sides (see section 18).

16. Remove the right damper fork bolt.

17. Remove the right radius rod.

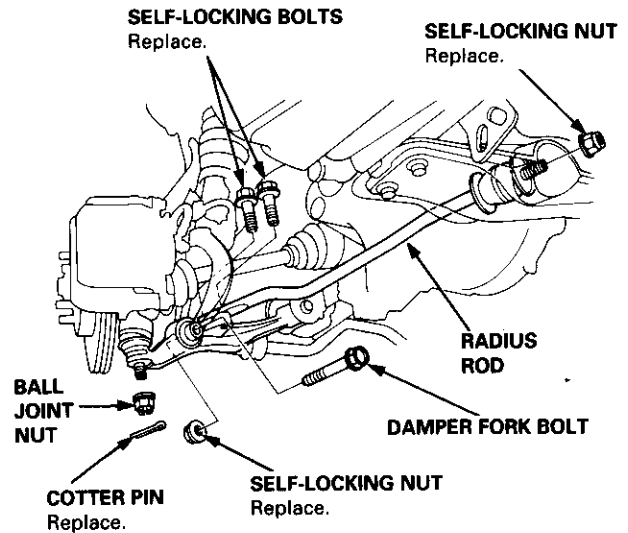

18. Remove the driveshafts and intermediate shaft (see section 16).

NOTE: Coat all precision finished surfaces with clean engine oil or grease. Tie plastic bags over the driveshaft ends.

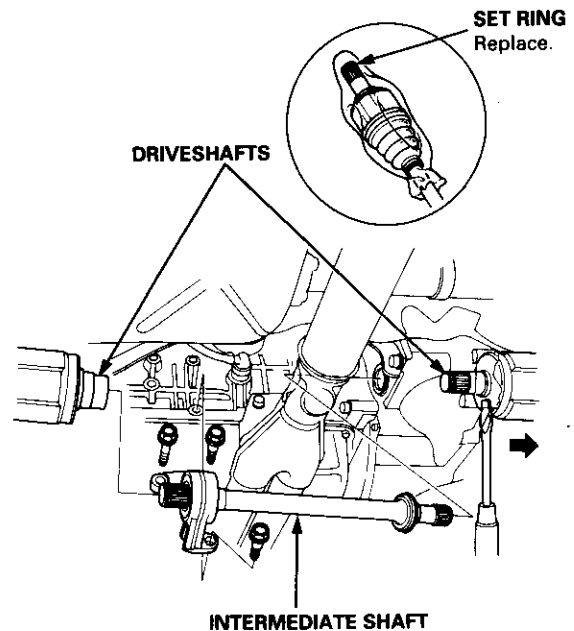



19. Remove the center beam.

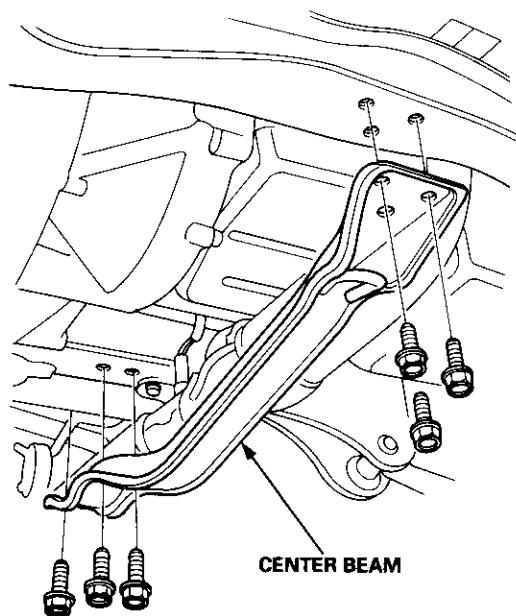

21. Remove the intake manifold stay.

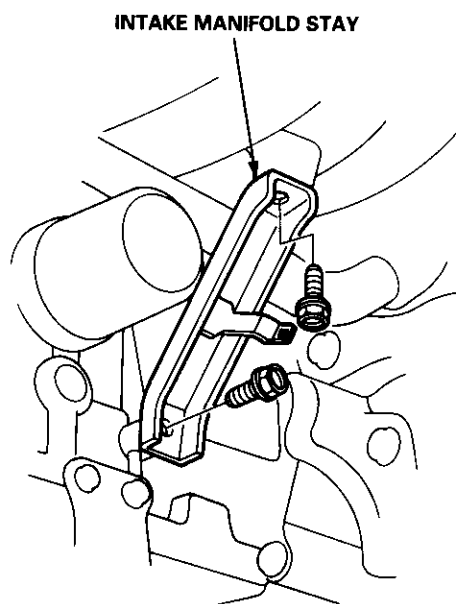

20. Remove the front engine stiffener and clutch cover.

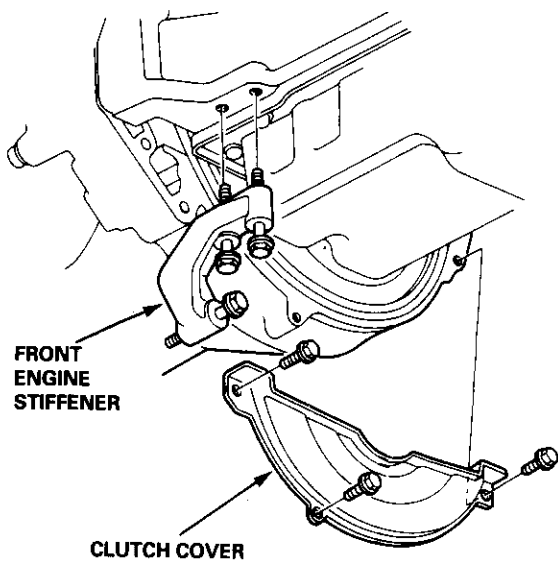

22. Remove the rear beam stiffener.

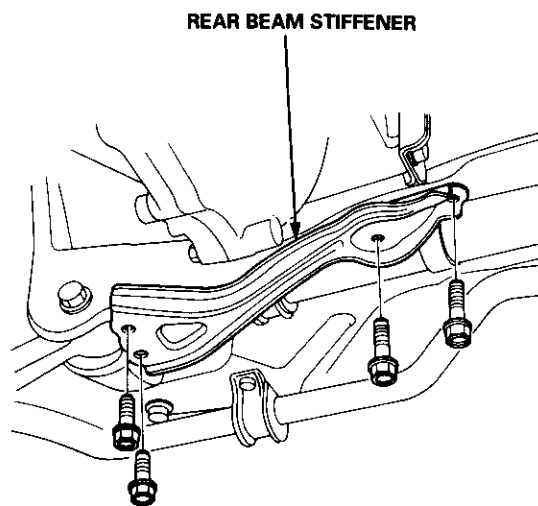

(cont'd)

Transmission Assembly

Removal (cont'd)

23. Remove the three rear engine mount bracket mounting bolts.

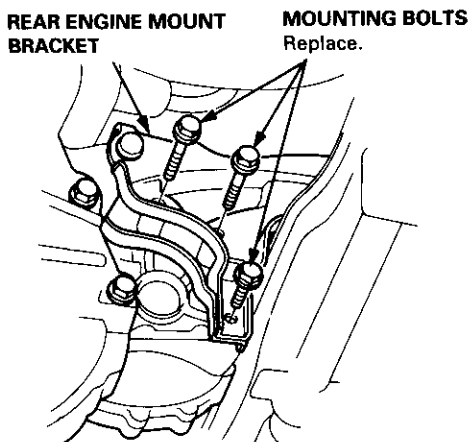

24. Place a floor jack under the transmission and raise the transmission just enough to take weight off of the mounts.

25. Remove the transmission mount and mount bracket.

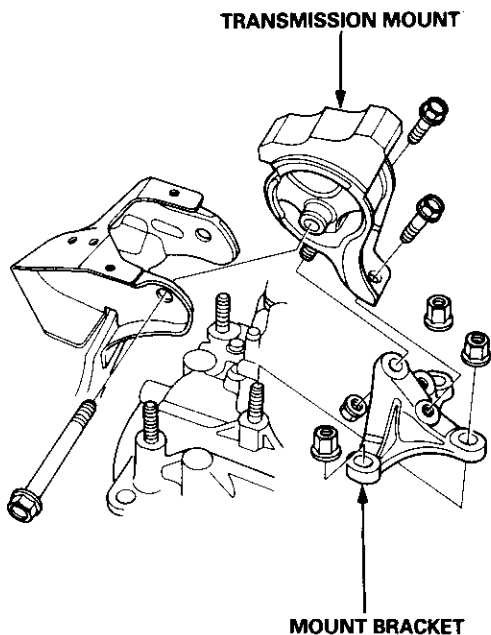

26. Remove the two upper transmission housing mounting bolts.

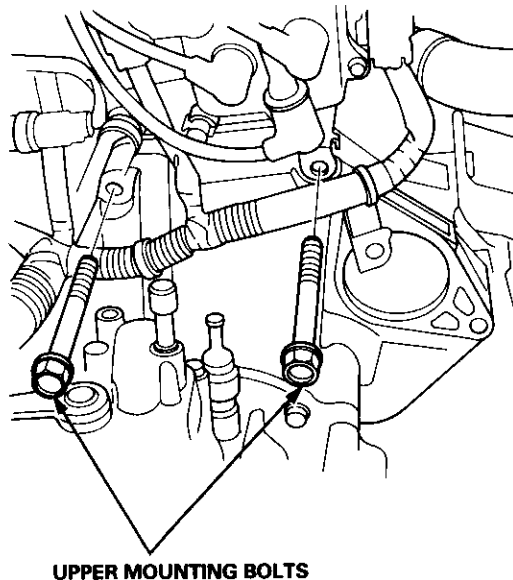

27. Remove the three lower transmission housing mounting bolts.

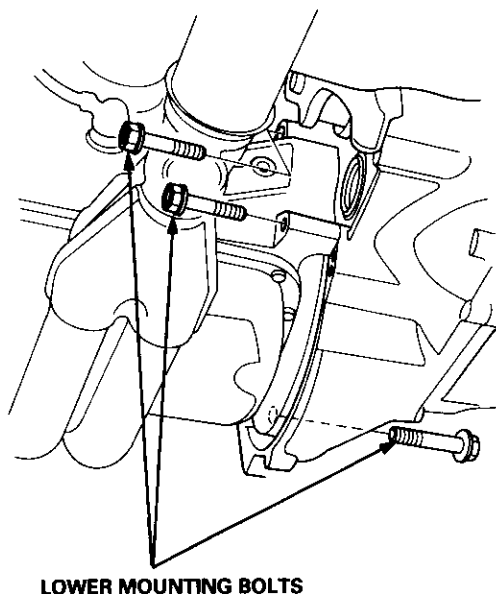

28. Pull the transmission away from the engine until it clears the mainshaft.



Gearshift Mechanism

Overhaul

NOTE:

- Inspect rubber parts for wear and damage when disassembling.
- Check that the new cotter pin is seated firmly.

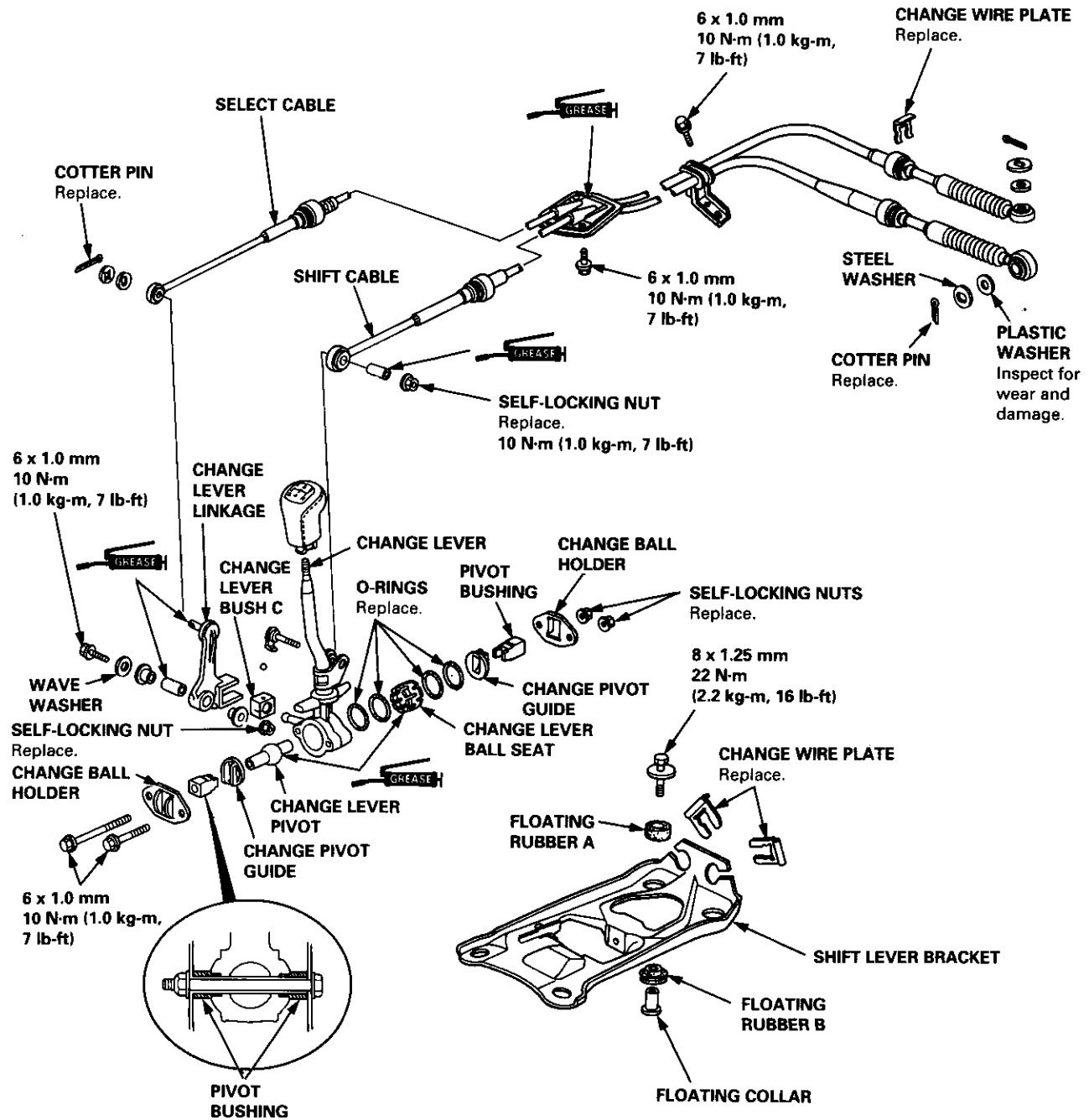

Illustrated Index

Refer to the drawing below for the transmission disassembly.
Clean all parts thoroughly in solvent and dry with compressed air.

 Lubricate all parts with oil before reassembly.

NOTE:

- This transmission uses no gaskets between the major housings; use liquid gasket (P/N 08718 — 0001) (see page 13-14, 39).
- Always clean the magnet ⑦ whenever the transmission housing is disassembled.

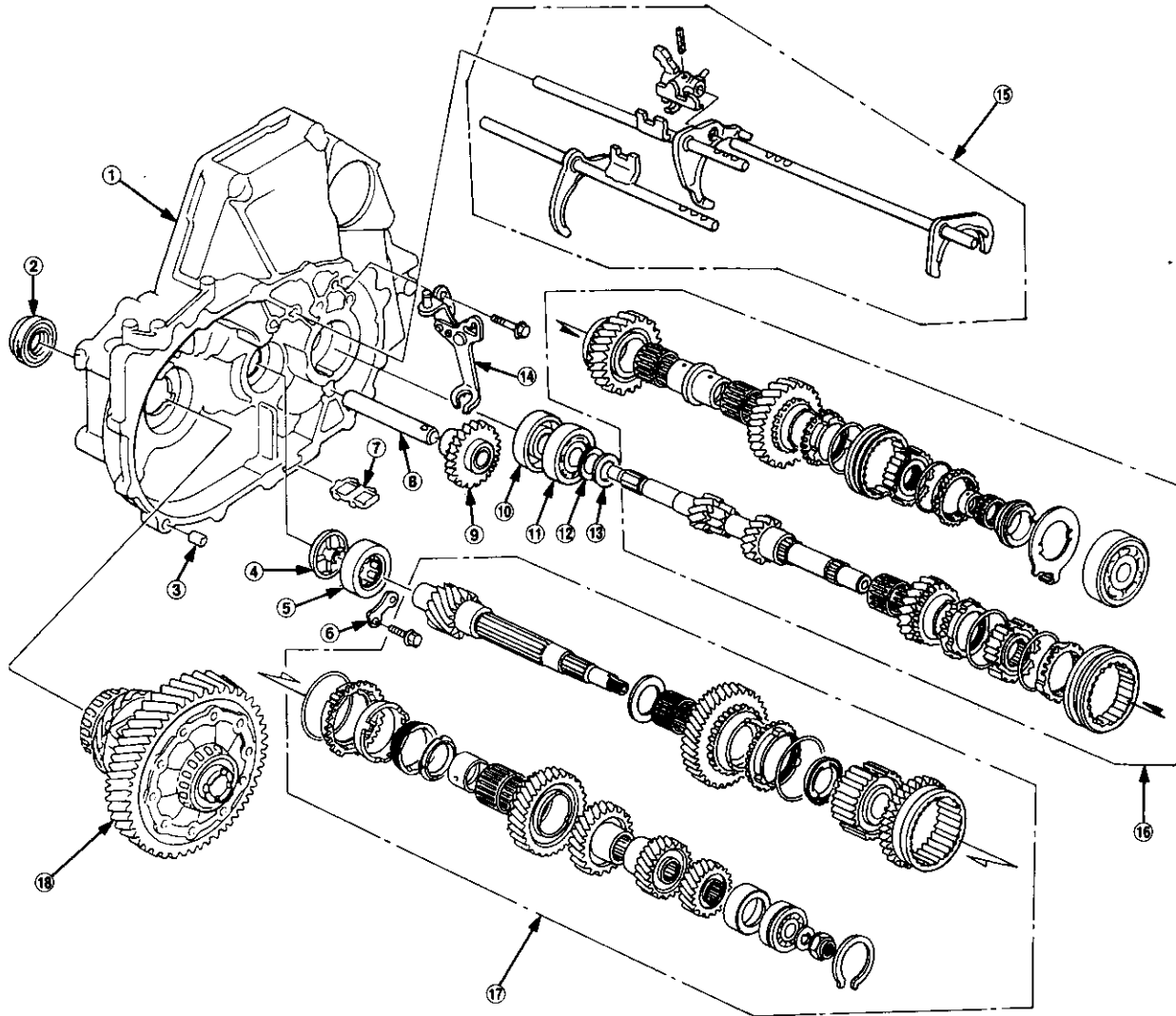

- | | | |
|---|---|---|
| <p>① CLUTCH HOUSING</p> <p>② OIL SEAL Replace.
• See section 15</p> <p>③ 14 x 20 mm DOWEL PIN</p> <p>④ OIL GUIDE PLATE</p> <p>⑤ NEEDLE BEARING
• Inspect for wear and operation.</p> <p>⑥ RETAINING PLATE</p> <p>⑦ MAGNET</p> | <p>⑧ REVERSE IDLER GEAR SHAFT</p> <p>⑨ REVERSE IDLER GEAR</p> <p>⑩ OIL SEAL Replace.</p> <p>⑪ BALL BEARING
• Inspect for wear and operation.</p> <p>⑫ SPRING WASHER</p> <p>⑬ WASHER</p> <p>⑭ REVERSE SHIFT FORK</p> | <p>⑮ SHIFT FORK ASSEMBLY
• Index, page 13-28</p> <p>⑯ MAINSHAFT ASSEMBLY
• Index, page 13-18</p> <p>⑰ COUNTERSHAFT ASSEMBLY
• Index, page 13-23</p> <p>⑱ DIFFERENTIAL ASSEMBLY
• See section 15</p> |
|---|---|---|

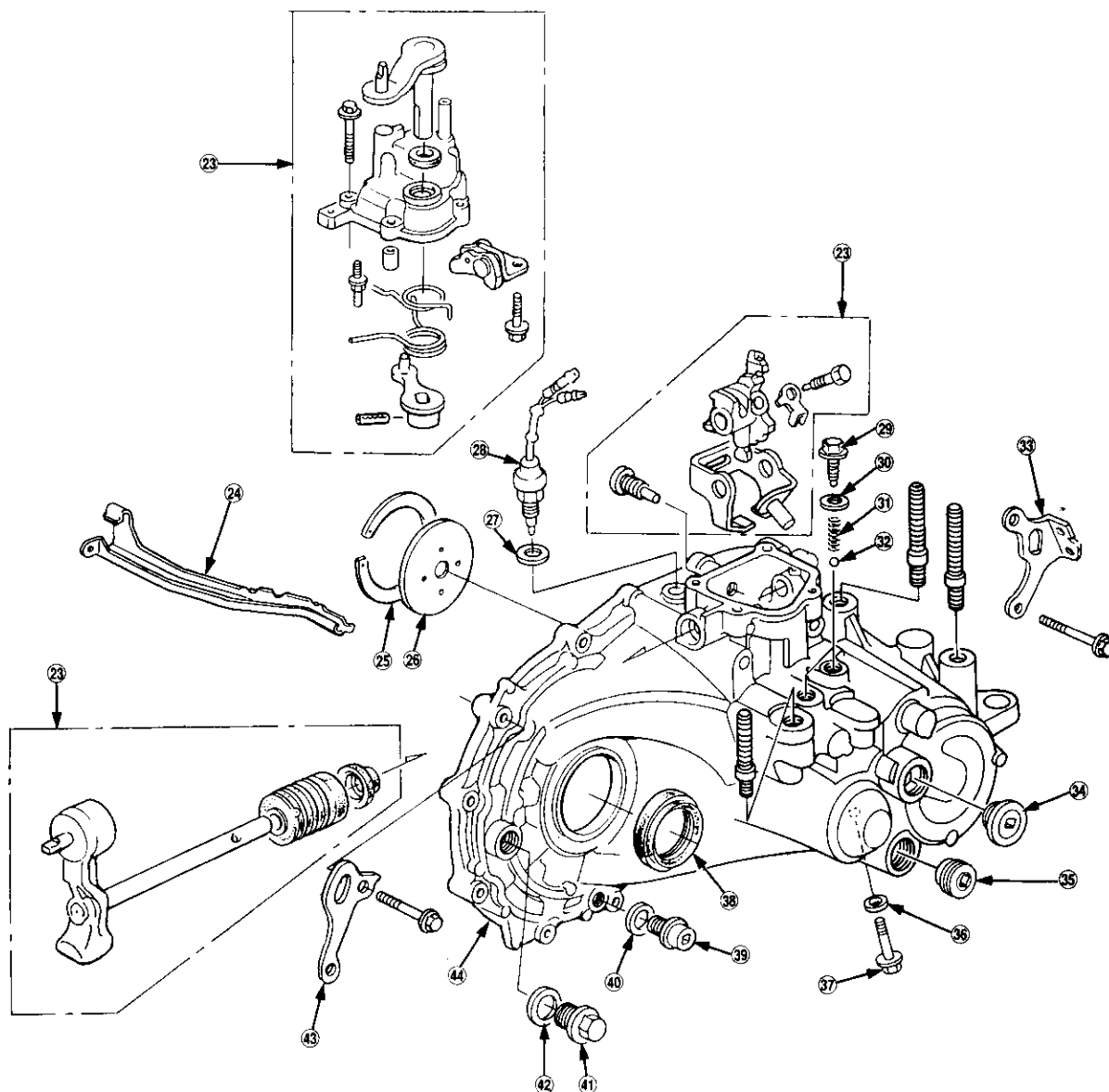

23 SHIFT ARM ASSEMBLY

• Index, page 13-12

24 OIL GUTTER PLATE

25 THRUST SHIM

• Selection, page 13-34

26 OIL GUIDE PLATE

WASHER Replace.

28 BACK-UP LIGHT SWITCH

29 SETTING SCREW

30 WASHER Replace.

31 SPRING (L. 30 mm)

32 STEEL BALL (D. 5/16 in)

33 TRANSMISSION HANGER

34 28 mm SEALING BOLT

35 32 mm SEALING BOLT

36 WASHER Replace.

**37 REVERSE IDLER GEAR
SHAFT BOLT**

38 OIL SEAL

• See section 15

39 OIL DRAIN PLUG

40 WASHER Replace.

41 OIL FILLER BOLT

42 WASHER Replace.

43 TRANSMISSION HANGER

44 TRANSMISSION HOUSING

Shift Arm Assembly

Index

NOTE:

- The shift arm cover can be removed and installed with the transmission in the car.
- Lubricate all moving and sliding surfaces with grease.
- Turn the boot so the hole is facing down.

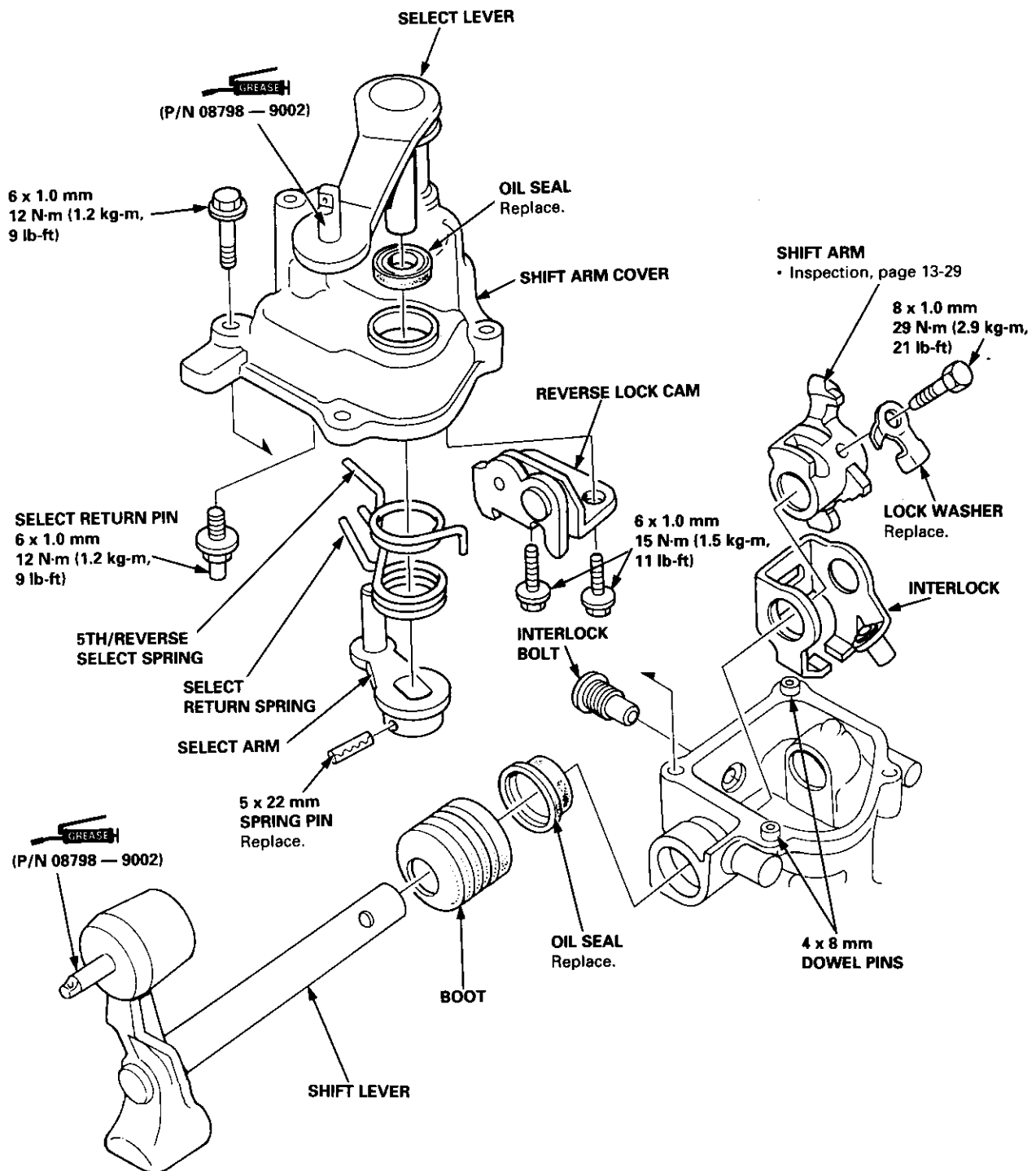



Disassembly/Reassembly

NOTE: During reassembly, grease all sliding parts.

1. Remove the shift arm cover assembly.

6 x 1.0 mm
12 N·m (1.2 kg-m, 9 lb-ft)

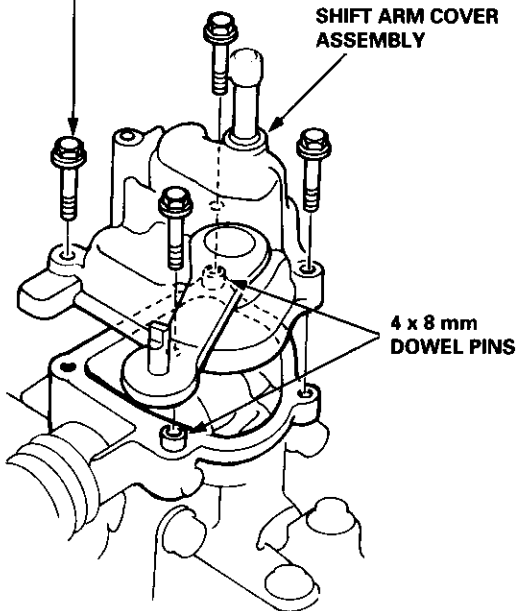

2. Remove the spring pin, then remove the select lever, select arm and springs.
3. Remove the select return pin.

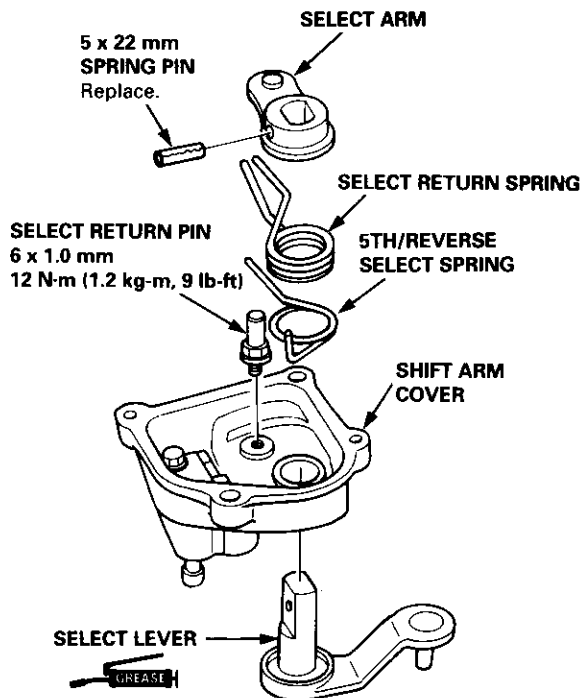

4. Remove the reverse lock cam.

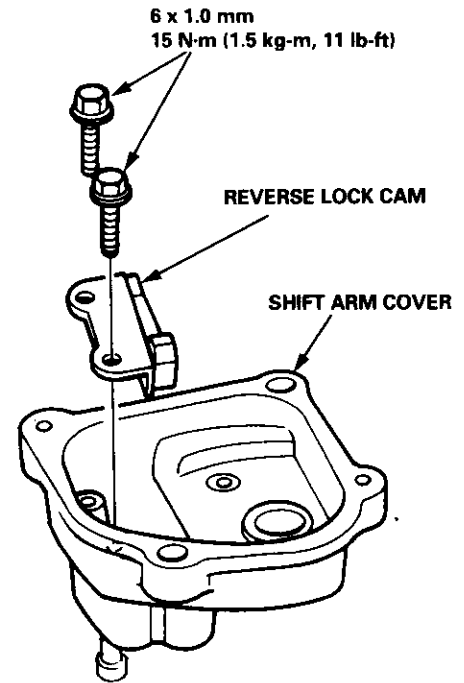

5. Remove the oil seal.

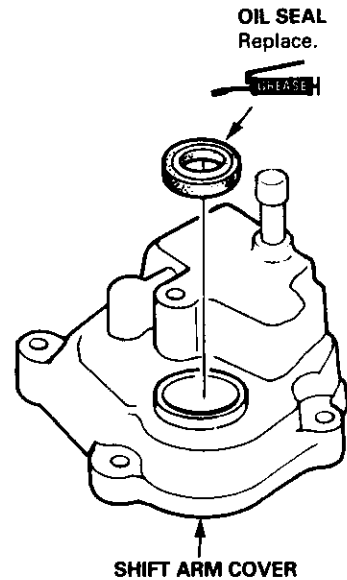

(cont'd)

Shift Arm Assembly

Disassembly/Reassembly (cont'd)

6. Bend the tab of the lock washer, then remove the bolt.
7. Remove the interlock bolt.

NOTE: Apply liquid gasket (P/N 08718 — 0001) to the threads before reassembly.

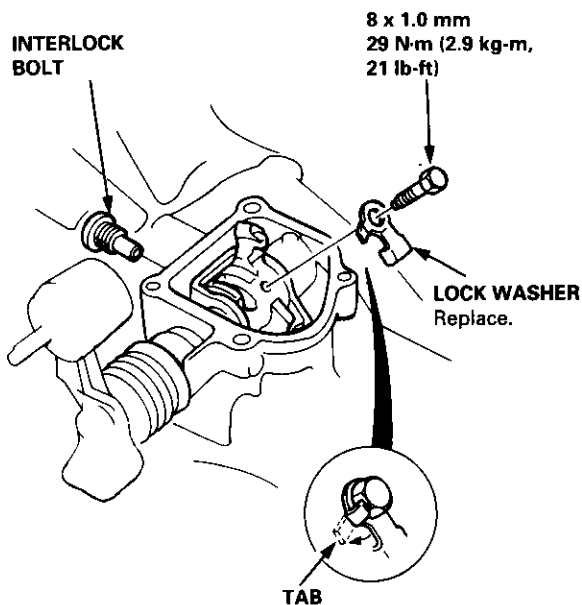

8. Remove the shift lever, shift arm, and interlock.

NOTE: Turn the boot so the hole is facing down.

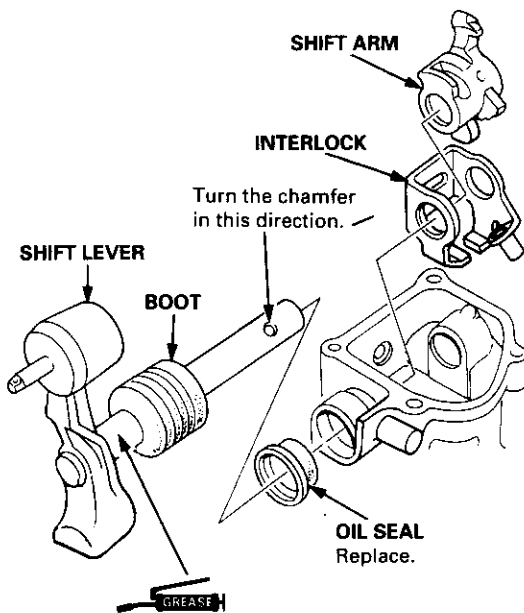

9. Install the shift arm assembly in the reverse order of removal.

NOTE:

- Use liquid gasket (P/N 08718 — 0001).
- Remove the dirt oil from the sealing surface.
- Seal the entire circumference of the bolt hole to prevent oil leakage.
- If 20 minutes have passed after applying liquid gasket, reapply it and assemble the housings and allow it to cure at least 30 minutes after assembly before filling transmission with oil.

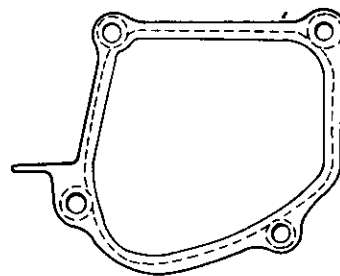

---: LIQUID GASKET

Transmission Housing



Removal

NOTE:

- If the transmission housing or clutch housing were replaced, the bearing preload must be adjusted.
- Place the clutch housing on two pieces of wood thick enough to keep the mainshaft from hitting the workbench.

1. Remove the shift arm cover assembly (see page 13-13).
2. Remove the reverse idler gear shaft bolt.
3. Remove the setting screws, then remove the washers, springs, and steel balls.

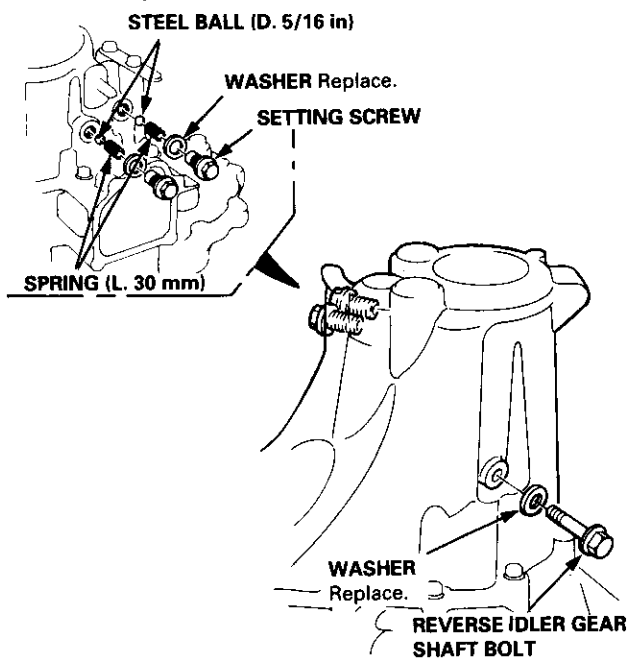

4. Remove the back-up light switch.
5. Remove the 10 mm bolts and 8 mm bolts in a criss-cross pattern in several steps.

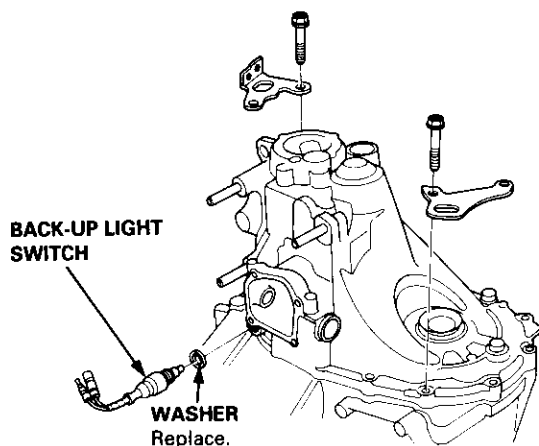

6. Remove the 32 mm sealing bolt.
7. Expand the snap ring on the countershaft ball bearing and remove it from the groove using a pair of snap ring pliers.
8. Separate the transmission housing from the clutch housing and wipe it clean of the sealant.

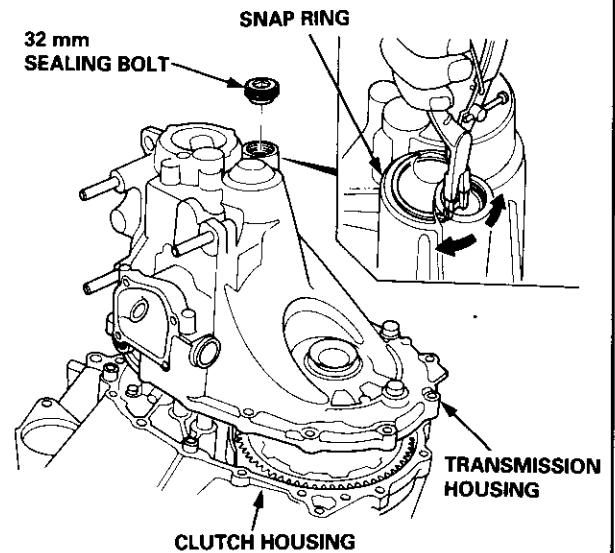

9. Remove the 28 mm sealing bolt, then remove the oil gutter plate.

NOTE: The transmission housing can be removed with the oil gutter plate in the transmission housing.

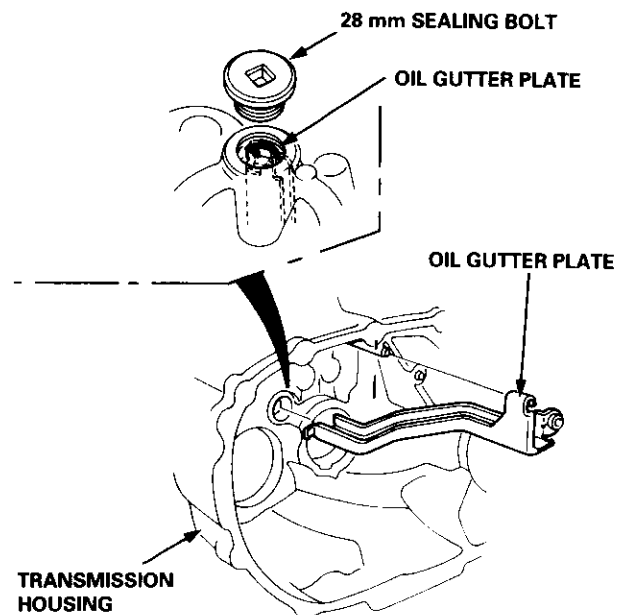

Reverse Shift Fork

Clearance Inspection

1. Measure the clearance between the reverse shift fork and 5th/reverse shift piece pin.

Standard: A: 0.05 — 0.35 mm (0.002 — 0.014 in)

B: 0.4 — 0.8 mm (0.016 — 0.031 in)

Service Limit: A: 0.5 mm (0.020 in)

B: 1.0 mm (0.039 in)

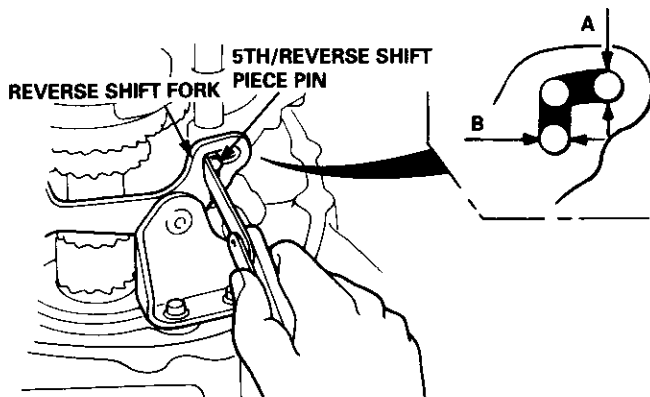

2. If the clearance exceeds the service limit, measure the width of the groove in the reverse shift fork.

Standard: A: 7.05 — 7.25 mm (0.278 — 0.285 in)

B: 7.4 — 7.7 mm (0.291 — 0.303 in)

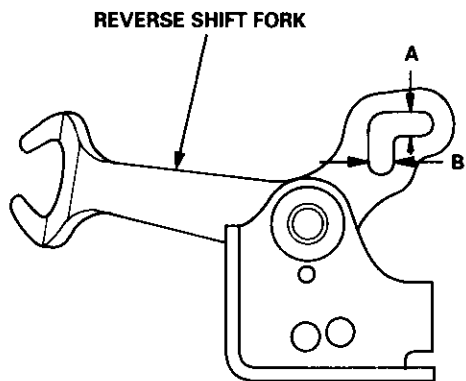

If the width of the groove exceeds the standard, replace the reverse shift fork with a new one.

If the width of the groove is within the standard, replace the 5th/reverse shift piece with a new one.

3. Measure the clearance between the reverse idler gear and reverse shift fork.

Standard: 0.5 — 1.1 mm (0.020 — 0.043 in)

Service Limit: 1.8 mm (0.071 in)

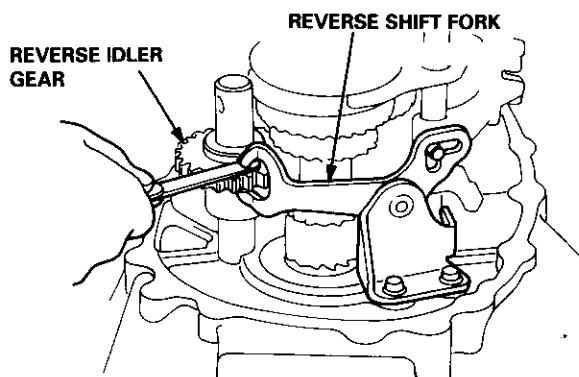

4. If the clearance exceeds the service limit, measure the width of the reverse shift fork.

Standard: 13.0 — 13.3 mm (0.512 — 0.524 in)

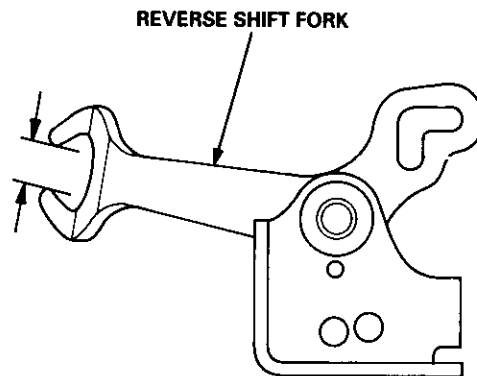

If the width exceeds the standard, replace the reverse shift fork with a new one.

If the width is within the standard, replace the reverse idler gear with a new one.

Reverse Idler Gear

Removal

1. Remove the reverse shift fork.

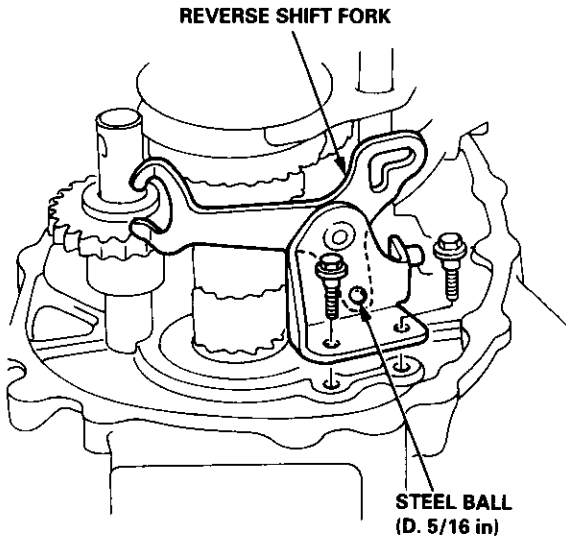

2. Remove the reverse idler gear shaft and the reverse idler gear.

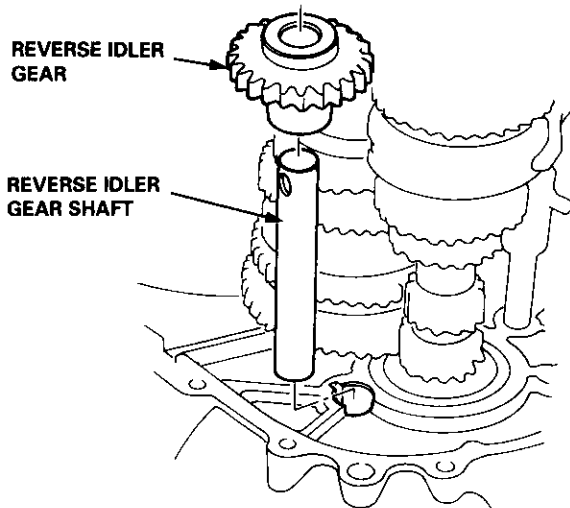

Mainshaft, Countershaft



Removal

1. Remove the mainshaft and countershaft assemblies with the shift forks from the clutch housing.

NOTE: Tape the mainshaft spline before removing the mainshaft and countershaft assemblies.

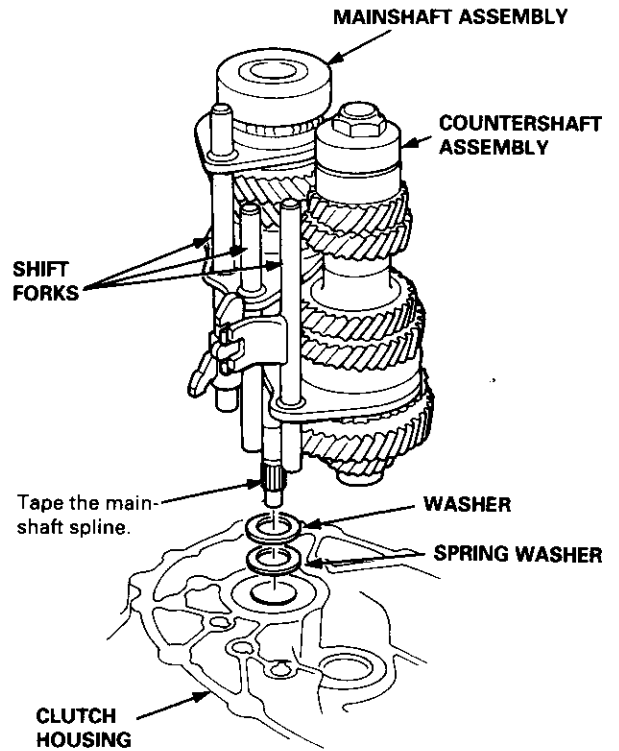

2. Remove the differential assembly.

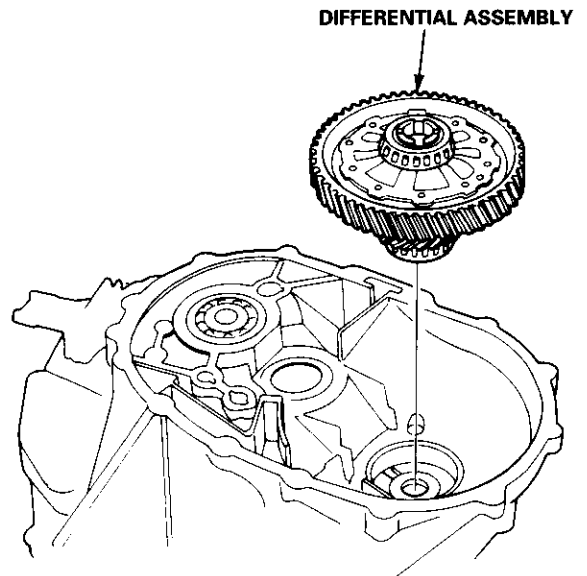

Mainshaft

Index



Before assembling, clean all parts in solvent, dry them with compressed air, then coat them with clean oil.

M2F4:

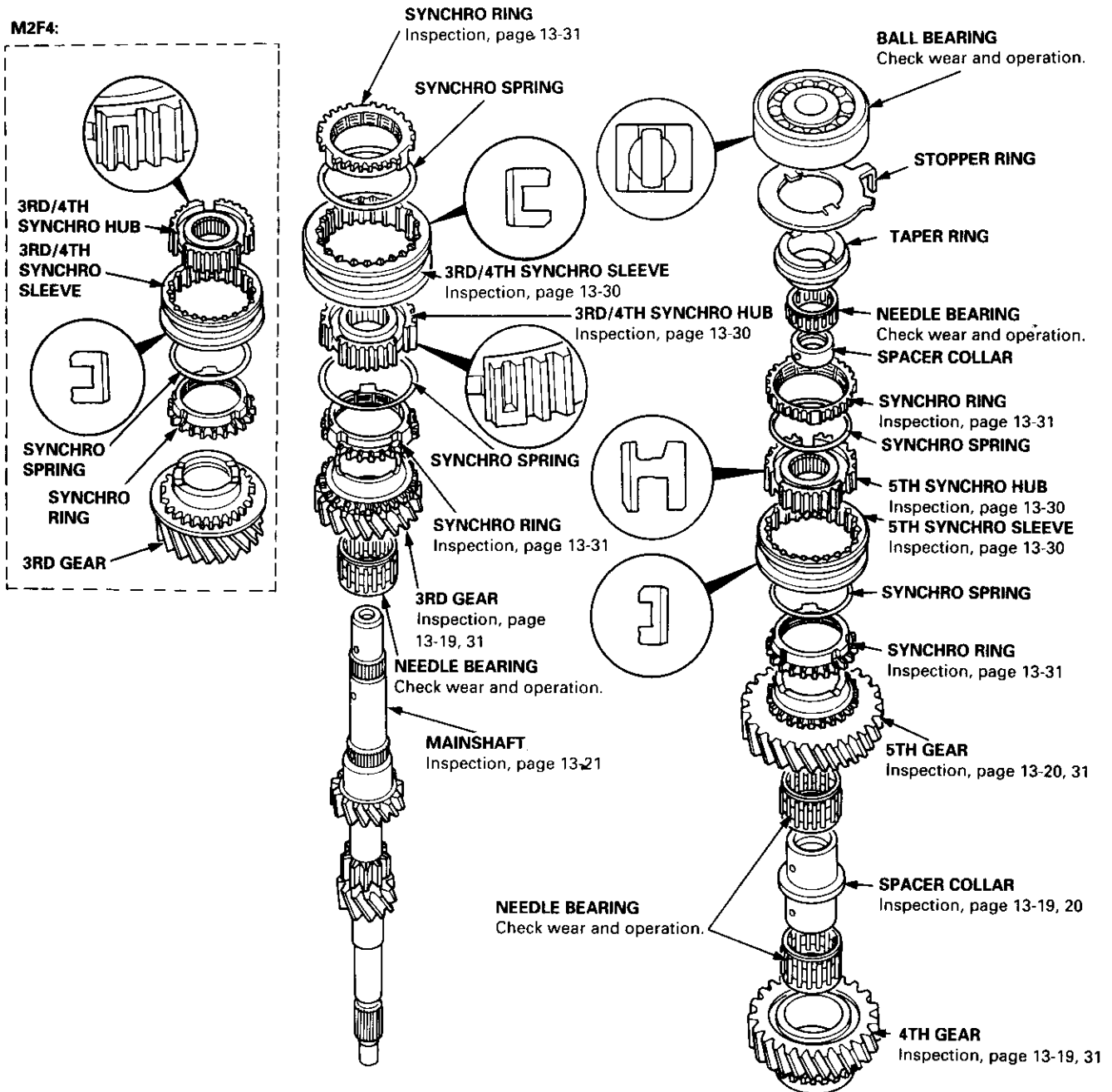



Clearance Inspection

NOTE: If replacement is required, always replace the synchro sleeve and hub as a set.

- Support the bearing inner race with a socket and push down on the mainshaft.
- Measure the clearance between 2nd and 3rd gears.

Standard: 0.06 — 0.21 mm
(0.002 — 0.008 in)
Service Limit: 0.3 mm (0.012 in)

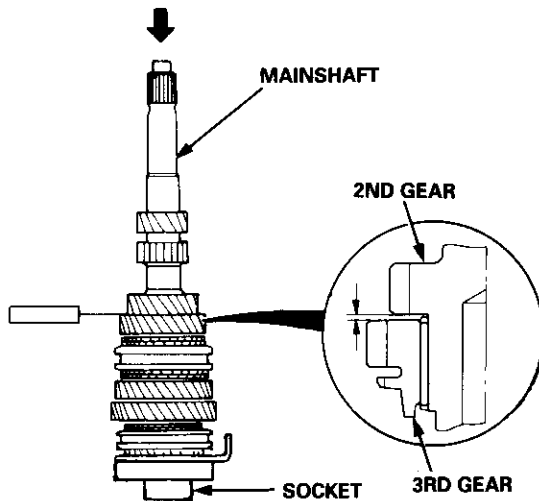

- If the clearance exceeds the service limit, measure the thickness of 3rd gear.

Transmission Type	M2L5, M2S4	M2F4
Standard	32.42 — 32.47 mm (1.276 — 1.278 in)	34.92 — 34.97 mm (1.375 — 1.377 in)
Service Limit	32.3 mm (1.272 in)	34.8 mm (1.370 in)

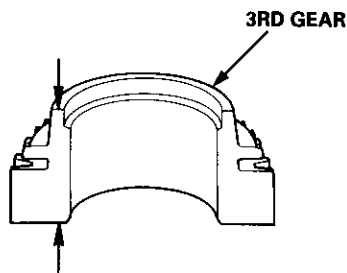

If the thickness of 3rd gear is less than the service limit, replace 3rd gear with a new one.
If the thickness of 3rd gear is within the service limit, replace the 3rd/4th synchro hub with a new one.

- Measure the clearance between 4th gear and the spacer collar.

Standard: 0.06 — 0.21 mm (0.002 — 0.008 in)
Service Limit: 0.3 mm (0.012 in)

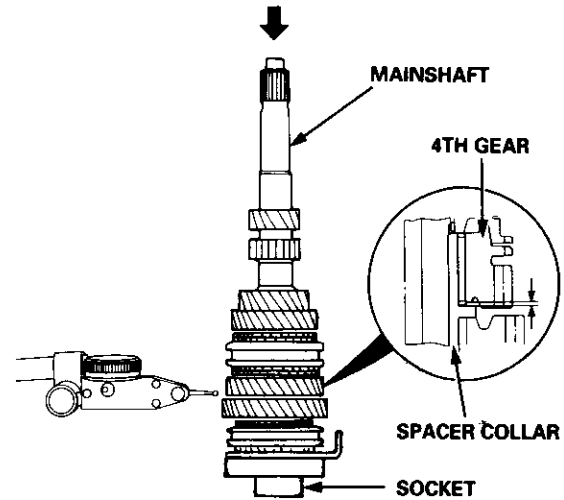

- If the clearance exceeds the service limit, measure distance (A) on the spacer collar.

Standard: 26.03 — 26.08 mm (1.025 — 1.027 in)
Service Limit: 26.01 mm (1.024 in)

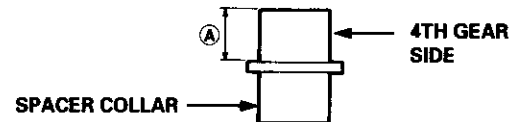

- If distance (A) is less than the service limit, replace the spacer collar with a new one.
If distance (A) is within the service limit, measure the thickness of 4th gear.

Transmission Type	M2L5, M2S4	M2F4
Standard	30.92 — 30.97 mm (1.217 — 1.219 in)	31.42 — 31.47 mm (1.237 — 1.239 in)
Service Limit	30.8 mm (1.213 in)	31.3 mm (1.232 in)

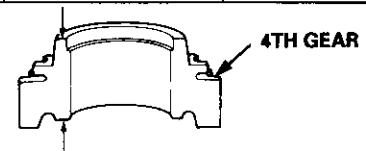

If the thickness of 4th gear is less than the service limit, replace 4th gear with a new one.
If the thickness of 4th gear is within the service limit, replace the 3rd/4th synchro hub with a new one.

(cont'd)

Mainshaft

Clearance Inspection (cont'd)

7. Measure the clearance between the spacer collar and 5th gear.

Standard: 0.06 — 0.21 mm
(0.002 — 0.008 in)

Service Limit: 0.3 mm (0.012 in)

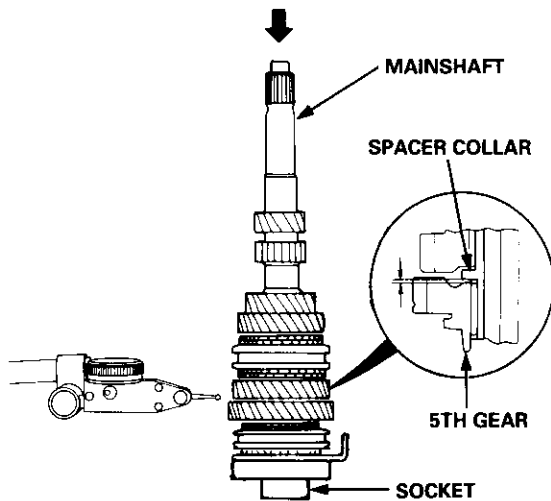

8. If the clearance exceeds the service limit, measure distance \textcircled{B} on the spacer collar.

Standard: 26.03 — 26.08 mm
(1.025 — 1.027 in)

Service Limit: 26.01 mm (1.024 in)

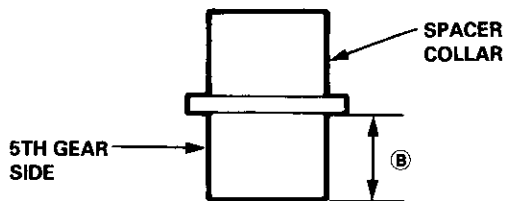

9. If distance \textcircled{B} is less than service limit, replace the spacer collar with a new one.
If distance \textcircled{B} is within the service limit, measure thickness of 5th gear.

Standard: 30.92 — 30.97 mm (1.217 — 1.219 in)
Service Limit: 30.8 mm (1.213 in)

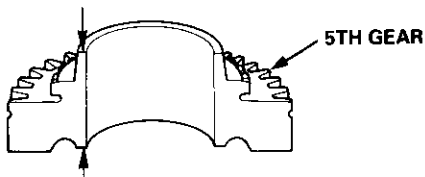

If the thickness of 5th gear is less than the service limit, replace 5th gear with a new one.

If the thickness of 5th gear is within the service limit, replace the 5th synchro hub with a new one.

Disassembly

CAUTION: Remove the synchro hubs using a press and steel blocks as shown. Use of a jaw-type puller can damage the gear teeth.

1. Remove the ball bearing using a bearing puller as shown.

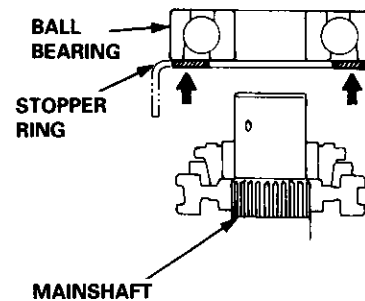
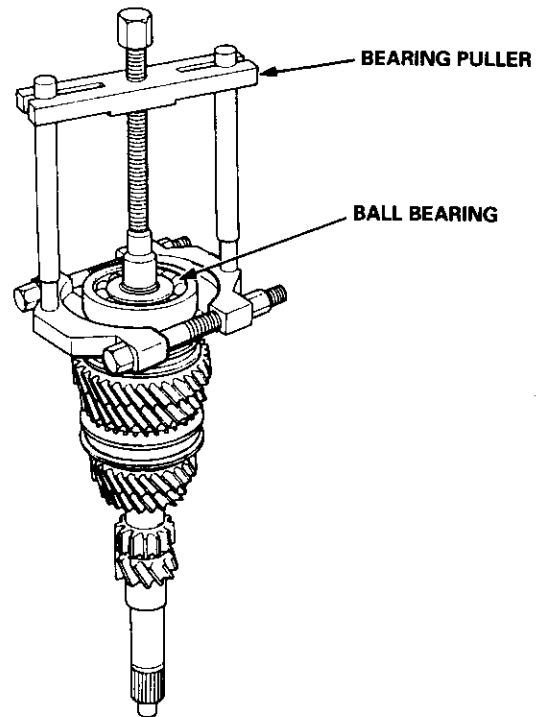



- Support 5th gear on steel blocks as shown and press the shaft out of the 5th synchro hub.

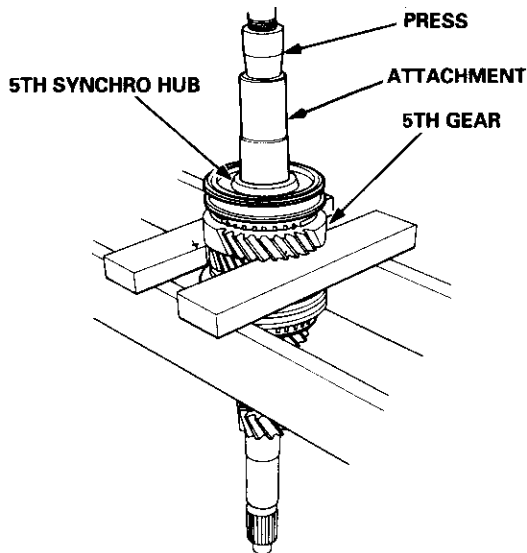

- In the same manner as above, support the 3rd gear on steel blocks and press the shaft out of the 3rd/4th synchro hub as shown.

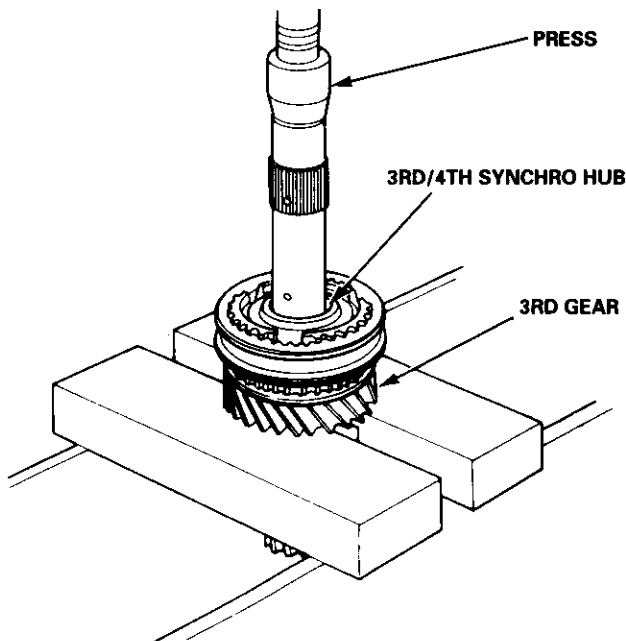

Inspection

- Inspect the gear surface and bearing surface for wear and damage, then measure the mainshaft at points A, B, and C.

Standard:

A (Ball bearing surface): 27.987 — 28.000 mm
(1.1018 — 1.1024 in)

B (Needle bearing surface): 37.984 — 38.000 mm
(1.4954 — 1.4961 in)

C (Ball bearing surface): 27.977 — 27.990 mm
(1.1015 — 1.1020 in)

Service Limit: A: 27.940 mm (1.1000 in)

B: 37.930 mm (1.4933 in)

C: 27.940 mm (1.1000 in)

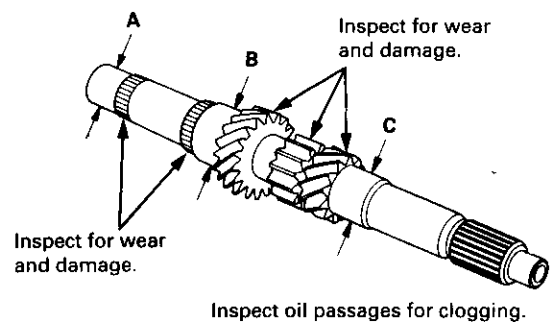

If any part of the mainshaft is less than the service limit, replace it with a new one.

- Inspect for runout.

Standard: 0.02 mm (0.001 in) max.

Service Limit: 0.05 mm (0.002 in)

NOTE: Support the mainshaft at both ends as shown.

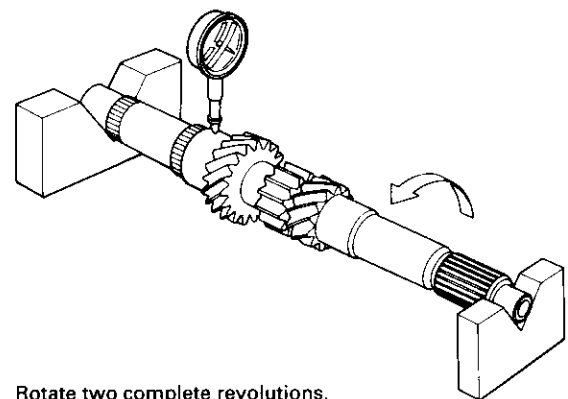

If the runout exceeds the service limit, replace the mainshaft with a new one.

Mainshaft

Reassembly

NOTE: Refer to page 13-18 for reassembly sequence.

1. Support 2nd gear on steel blocks as shown, then install the 3rd/4th synchro hub using the special tools and a press as shown.

NOTE: After installing, inspect the operation of the 3rd/ 4th synchro hub set.

M2L5, M2S4 (Transmission Type):

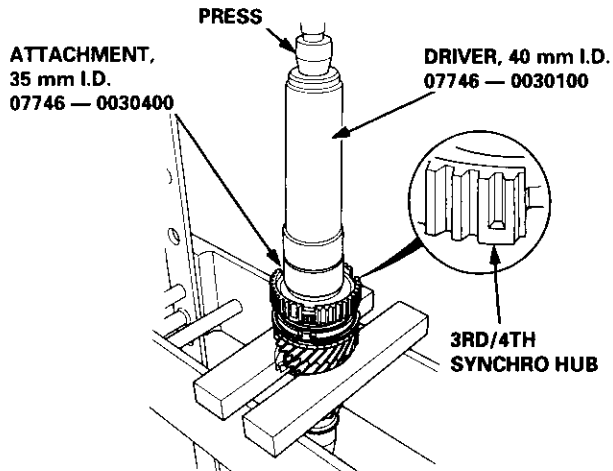

M2F4 (Transmission Type):

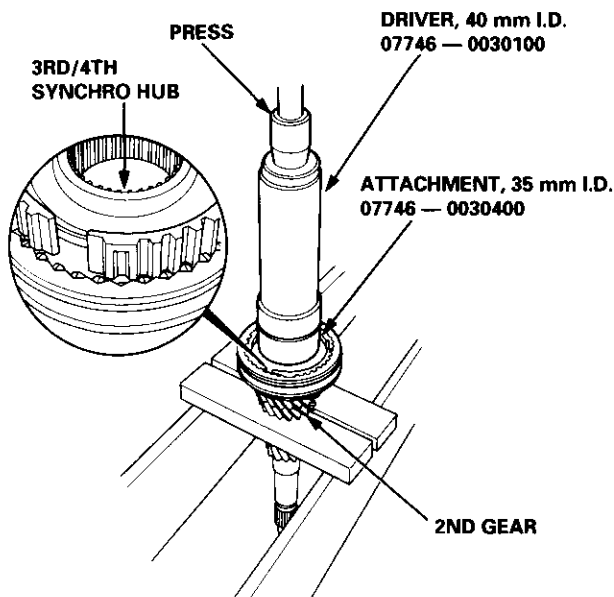

2. Install the 5th synchro hub using the special tools and a press as shown.

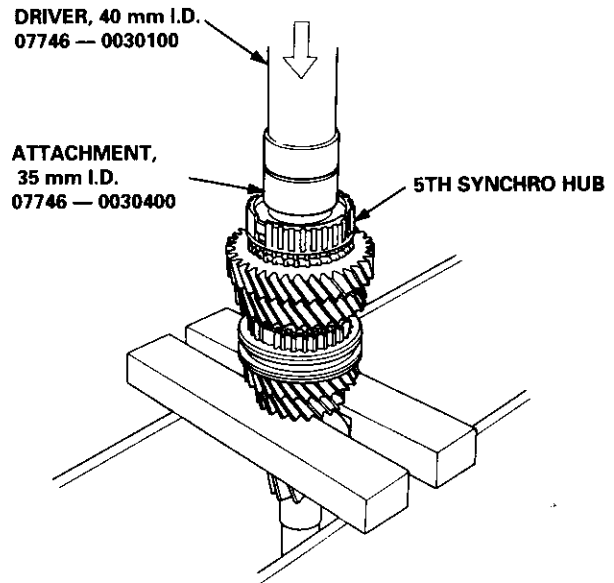

3. Install the ball bearing using the special tools and a press as shown.

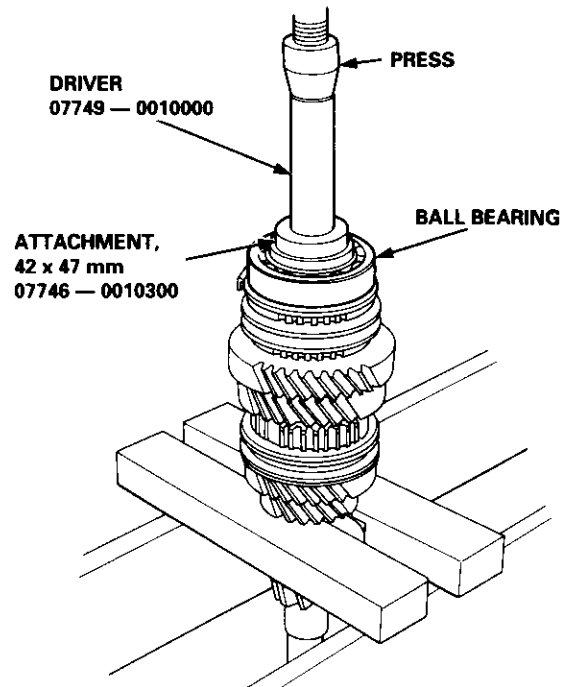

Countershaft



Index

 Before assembling, clean all parts in solvent, dry them with compressed air, then coat them with clean oil.

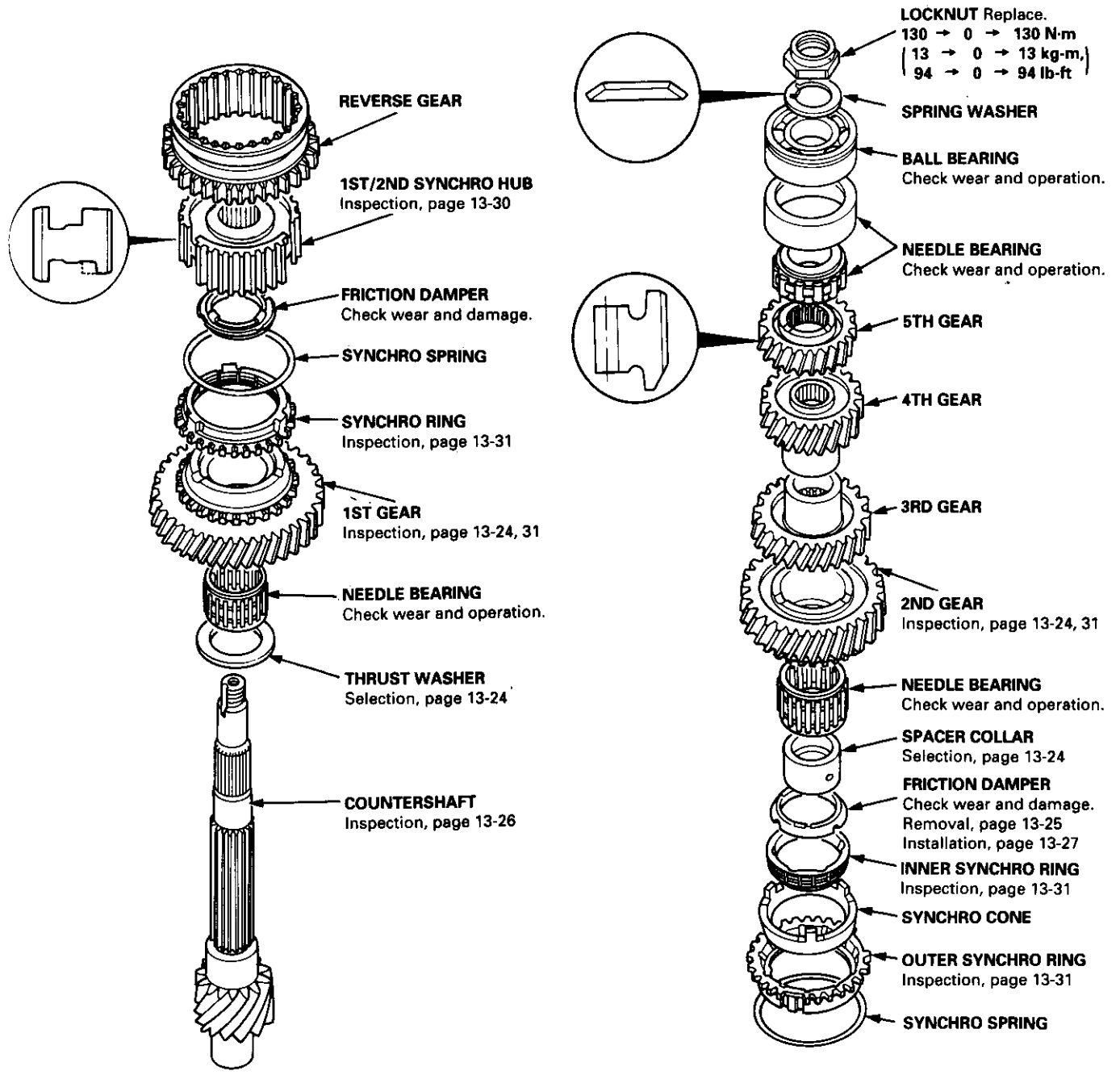

Countershaft

Clearance Inspection

1. Measure the clearance between the 1st gear and thrust washer.

Standard: 0.04 — 0.10 mm
(0.002 — 0.004 in)

Service Limit: 0.18 mm (0.007 in)

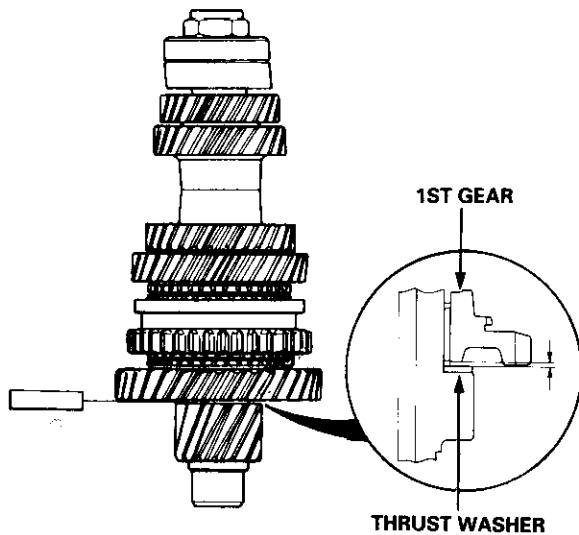

2. If the clearance exceeds the service limit, select the appropriate thrust washer for the correct clearance from the chart below.

THRUST WASHER

	Part Number	Thickness
A	23921 - PG1 - 000	1.96 mm (0.0771 in)
B	23922 - PG1 - 000	1.99 mm (0.0783 in)
C	23923 - PG1 - 000	2.02 mm (0.0795 in)
D	23924 - PG1 - 000	2.05 mm (0.0807 in)
E	23925 - PG1 - 000	2.08 mm (0.0819 in)

3. Measure the clearance between the 2nd gear and 3rd gear.

Standard: 0.04 — 0.10 mm
(0.002 — 0.004 in)

Service Limit: 0.18 mm (0.007 in)

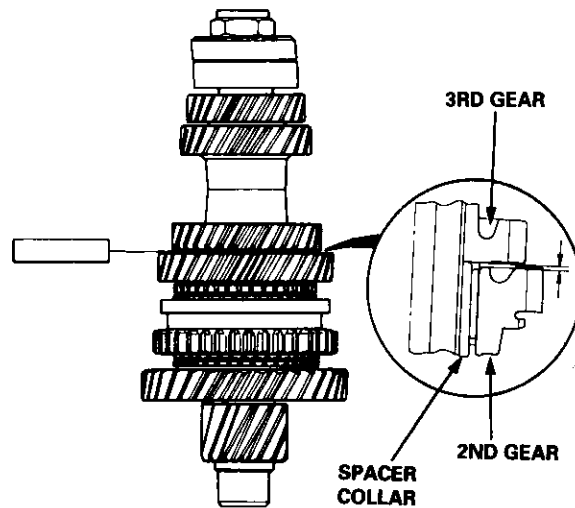

4. If the clearance exceeds the service limit, select the appropriate spacer collar for the correct clearance from the chart below.

SPACER COLLAR

	Part Number	Thickness
A	23917 - P21 - 010	29.02 - 29.04 mm (1.1425 - 1.1433 in)
B	23918 - P21 - 010	29.07 - 29.09 mm (1.1445 - 1.1453 in)



Disassembly

1. Securely clamp the countershaft assembly in a bench vise with wood blocks.
2. Raise the locknut tab from the groove of the shaft and remove the locknut and the spring washer.

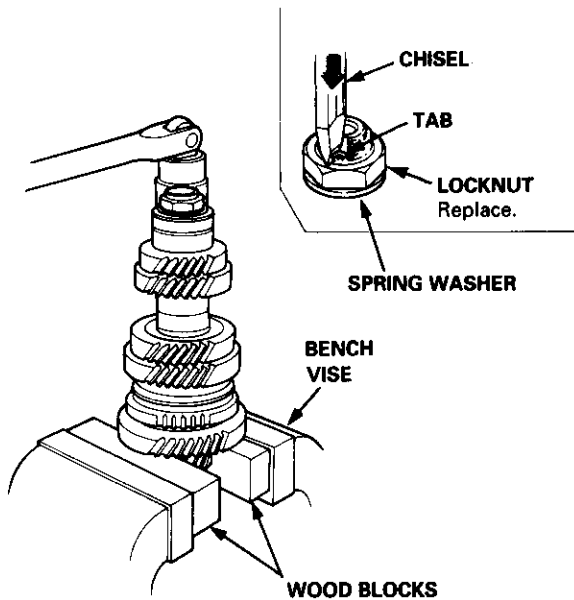

3. Remove the ball bearing using a press as shown.

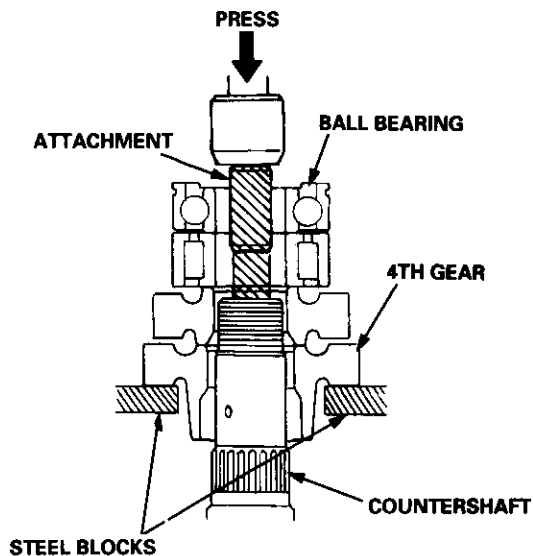

4. Remove the friction damper from the spacer collar using a press and a socket as shown.

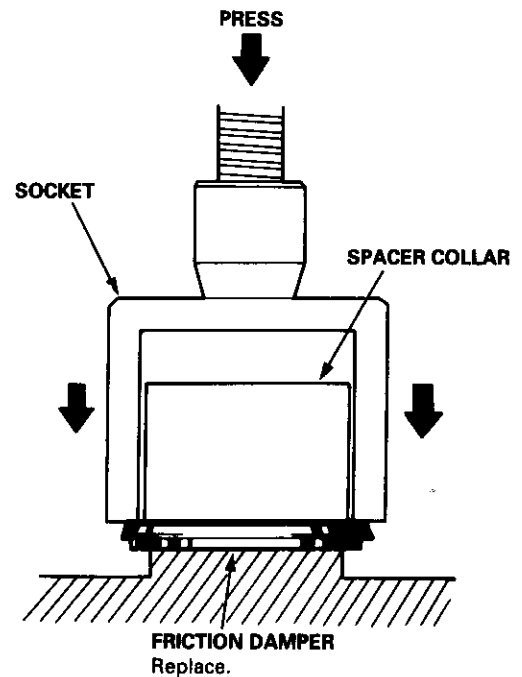

Countershaft

Inspection

1. Inspect the gear surface and bearing surface for wear and damage, then measure the countershaft at points A, B, and C.

Standard: **A:** 38.000 — 38.015 mm
 (1.4961 — 1.4967 in)
 B: 39.984 — 40.000 mm
 (1.5742 — 1.5748 in)
 C: 24.987 — 25.000 mm
 (0.9837 — 0.9843 in)

Service Limit: **A:** 37.950 mm (1.4941 in)
 B: 39.930 mm (1.5729 in)
 C: 24.940 mm (0.9819 in)

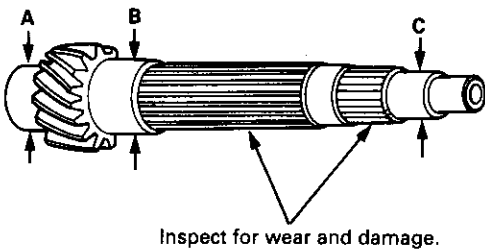

If any part of the countershaft is less than the service limit, replace it with a new one.

2. Inspect for runout.

Standard: 0.02 mm (0.001 in)
Service Limit: 0.05 mm (0.002 in)

NOTE: Support the countershaft at both ends as shown.

Rotate two complete revolutions.

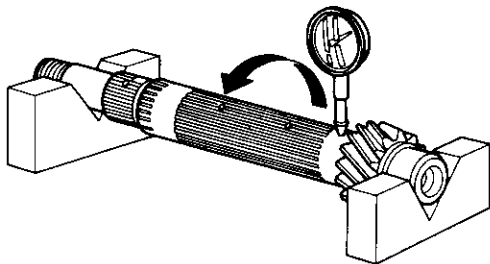

If the runout exceeds the service limit, replace the countershaft with a new one.

Reassembly

NOTE: Refer to page 13-23 for reassembly sequence.

1. Install the thrust shim, needle bearing, 1st gear, friction damper, synchro ring, and synchro spring.

NOTE: Reassemble the 1st gear and friction damper before installation.

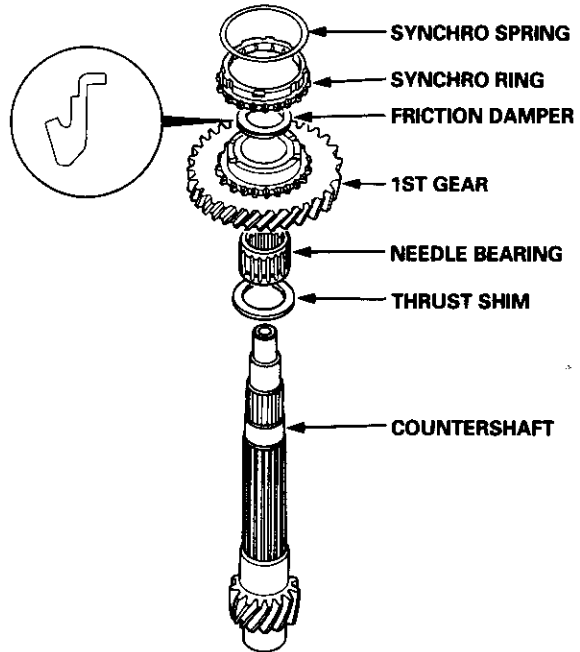

2. Install the 1st/2nd synchro hub by aligning the friction damper fingers with 1st/2nd synchro hub grooves.

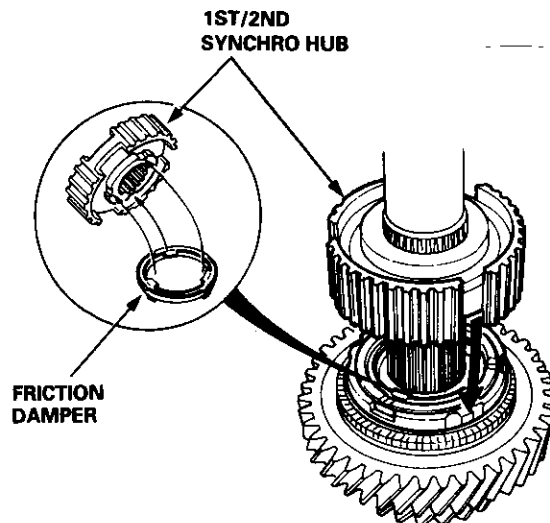



3. Install the friction damper on the spacer collar using the special tools and a press as shown.

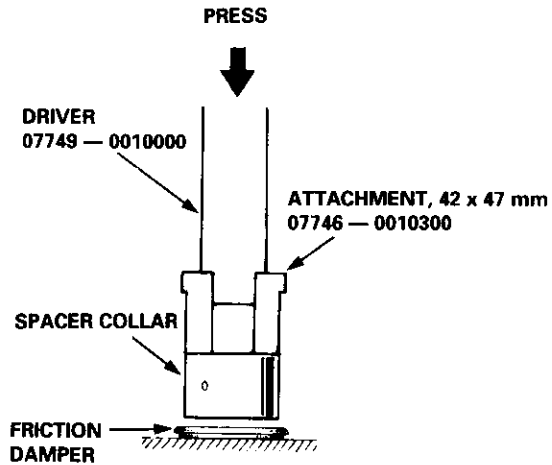

4. Install the 2nd gear by aligning the synchro cone fingers with 2nd gear grooves.

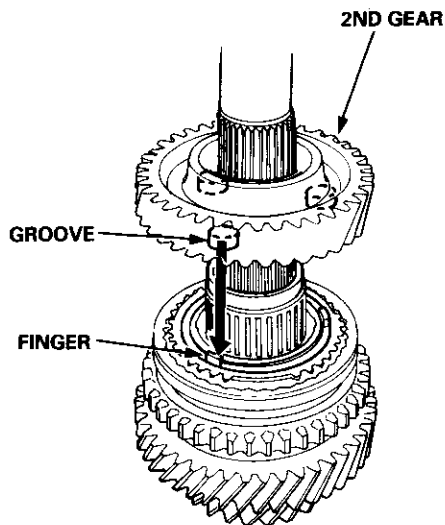

5. Install the needle bearing.
6. Install the ball bearing using a special tool and a press as shown.

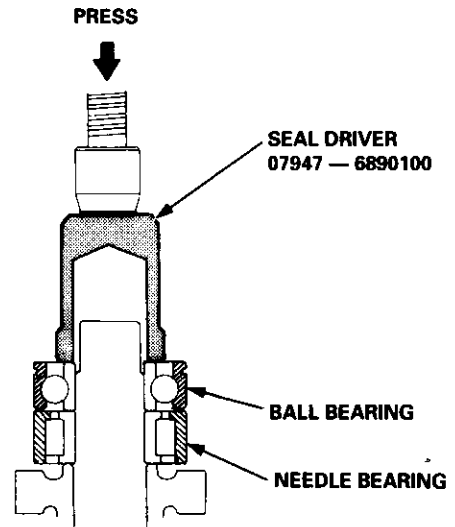

7. Install the spring washer.
8. Securely clamp the countershaft assembly in a bench vise with wood blocks.
9. Tighten the new locknut to the correct torque, then stake the locknut tab into the groove.

Torque: 130 → 0 → 130 N·m (13.0 → 13.0 kg·m,
94 → 0 → 94 lb·ft)

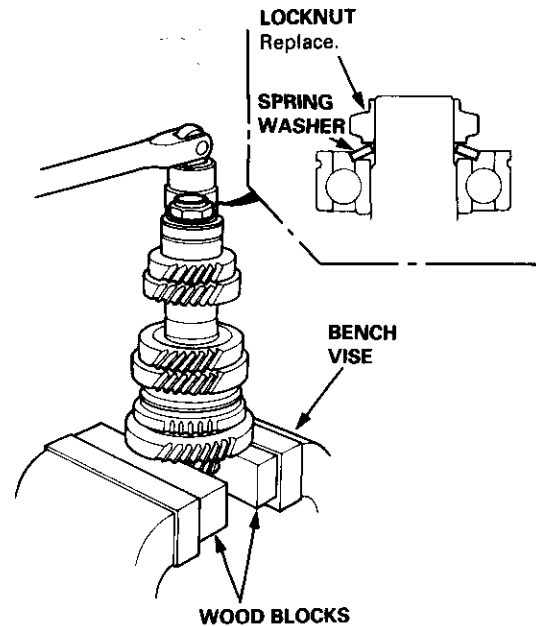

Shift Fork Assembly

Disassembly/Reassembly

 Prior to reassembling, clean all the parts in solvent, dry them and apply lubricant to any contact parts.

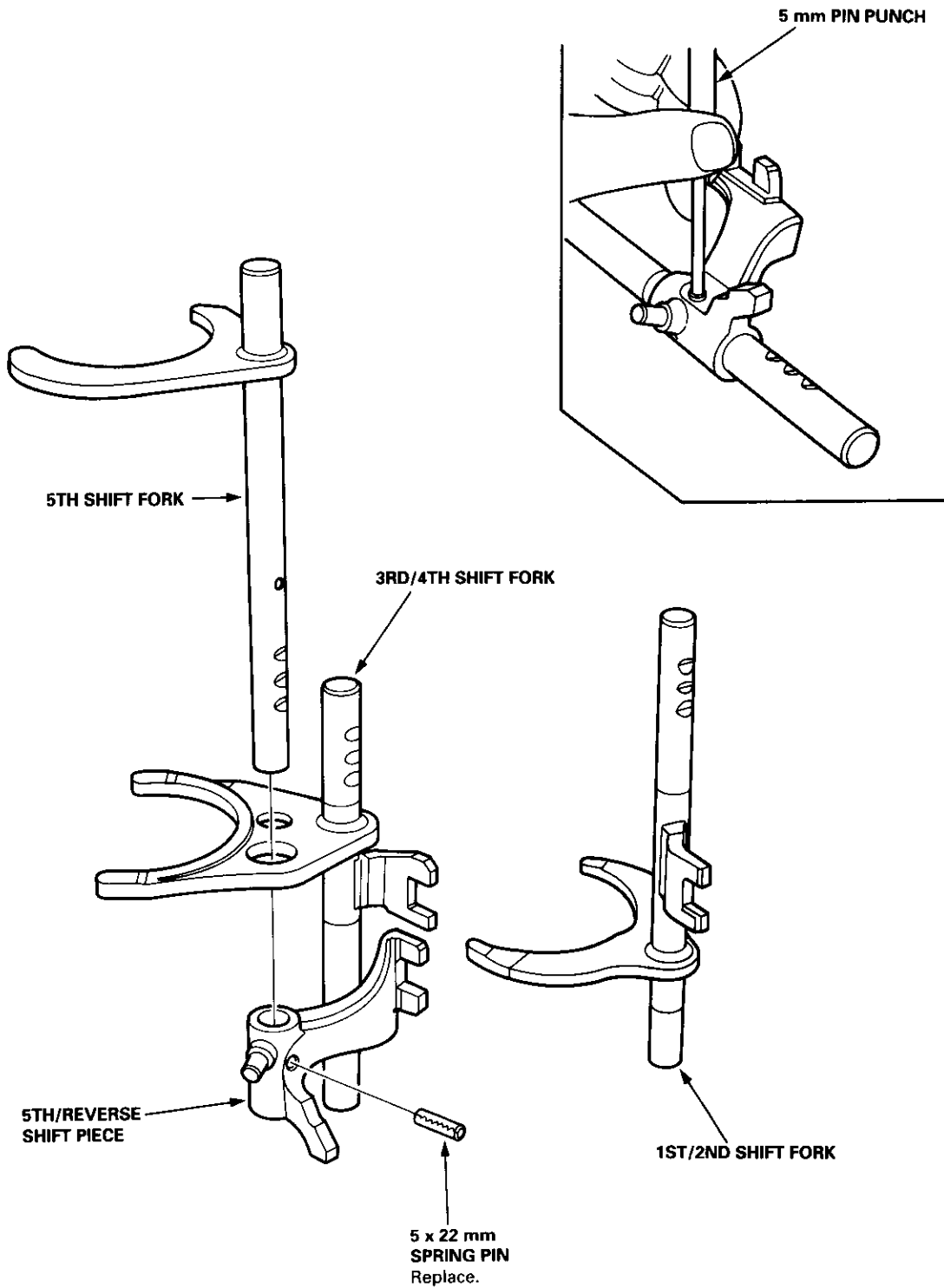



Clearance Inspection

NOTE: The synchro sleeve and synchro hub should be replaced as a set.

1. Measure the clearance between each shift fork and its matching synchro sleeve.

Standard: 0.35 — 0.65 mm (0.014 — 0.026 in)
Service Limit: 1.00 mm (0.039 in)

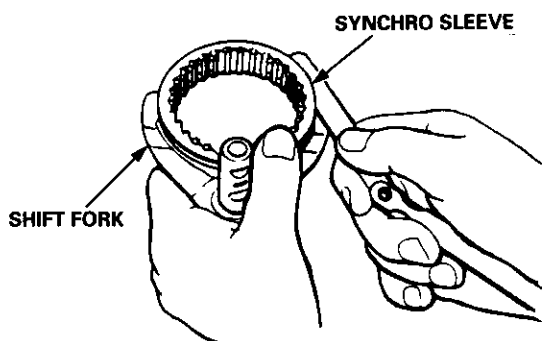

2. If the clearance exceeds the service limit, measure the thickness of the shift fork fingers.

Standard:

M2F4 (Transmission Type) 3rd/4th shift fork	7.4 — 7.6 mm (0.291 — 0.299 in)
M2L5/M2S4 (Transmission Type) 3rd/4th shift fork	6.2 — 6.4 mm (0.244 — 0.252 in)

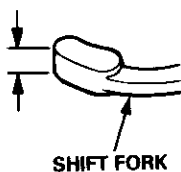

If the thickness of the shift fork finger is less than the standard, replace the shift fork with a new one.
If the thickness of the shift fork finger is within the standard, replace the synchro sleeve with a new one.

3. Measure the clearance between the shift fork and the shift arm.

Standard: 0.2 — 0.5 mm (0.008-0.019 in)
Service Limit: 0.6 mm (0.024 in)

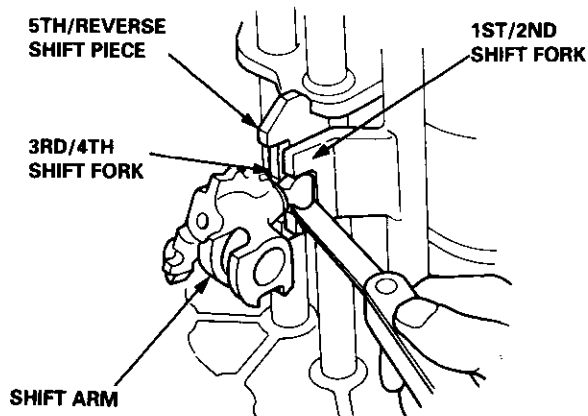

4. If the clearance exceeds the service limit, measure the width of the shift arm.

Standard: 12.9 — 13.0 mm (0.508 — 0.512 in)

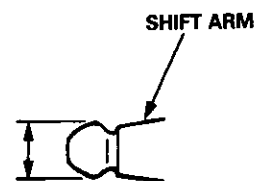

If the width of the shift fork finger is less than the standard, replace the shift arm with a new one.
If the width of the shift fork finger is within the standard, replace the shift fork or shift piece with a new ones.

Synchro Sleeve, Synchro Hub

Inspection

1. Inspect gear teeth on all synchro hubs and synchro sleeves for rounded off corners, which indicates wear.
2. Install each synchro hub in its mating synchro sleeve and check for freedom of movement.

NOTE: If replacement is required, always replace the synchro sleeve and synchro hub as a set.

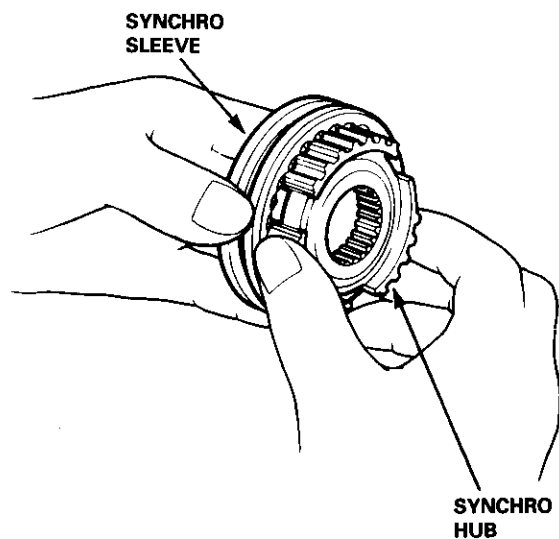

Installation

Each synchro sleeve has three sets of longer teeth (120 degrees apart) that must be matched with the three sets of deeper grooves in the synchro hub when assembled.

NOTE: Installing the synchro sleeve with its longer teeth in the 1st/2nd synchro hub slots will damage the spring ring.

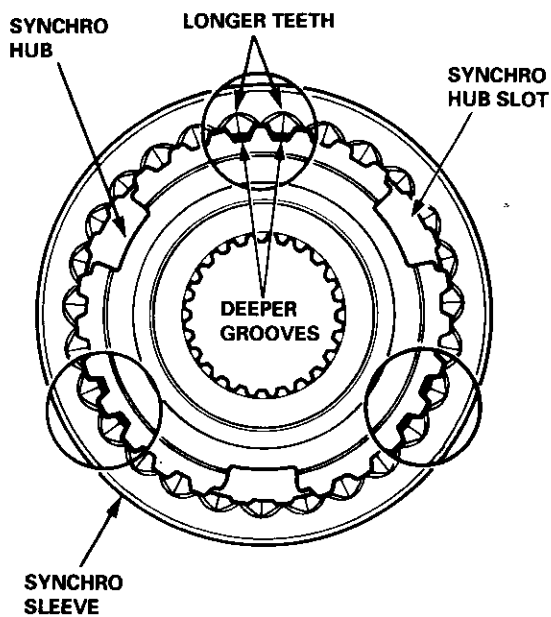

Synchro Ring, Gear



Inspection

1. Inspect the synchro ring and gear.

A: Inspect the inside of the synchro ring for wear.

B: Inspect the synchro sleeve teeth and matching teeth on the synchro ring for wear (rounded off).



C: Inspect the synchro sleeve teeth and matching teeth on the gear for wear (rounded off).

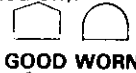

D: Inspect the gear hub thrust surface for wear.

E: Inspect the cone surface for wear and roughness.

F: Inspect the teeth on all gears for uneven wear, scoring, galling, and cracks.

2. Coat the cone surface of the gear with oil and place the synchro ring on the matching gear. Rotate the ring, making sure that it does not slip.

Measure the clearance between the synchro ring and gear all the way around.

NOTE: Hold the synchro ring against the gear evenly while measuring the clearance.

Synchro Ring-to-Gear Clearance

Standard: 0.85 — 1.10 mm
(0.033 — 0.043 in)

Service Limit: 0.4 mm (0.016 in)

Double Cone Synchro-to-Gear Clearance

Standard:

Ⓐ: (Outer Synchro Ring to Synchro Cone)
0.5 — 1.0 mm (0.020 — 0.039 in)

Ⓑ: (Synchro Cone to Gear)
0.5 — 1.0 mm (0.020 — 0.039 in)

Ⓒ: (Outer Synchro Ring to Gear)
0.95 — 1.68 mm (0.037 — 0.066 in)

Service Limit:

Ⓐ: 0.3 mm (0.012 in)

Ⓑ: 0.3 mm (0.012 in)

Ⓒ: 0.6 mm (0.024 in)

If the clearance is less than the service limit, replace the synchro ring and synchro cone.

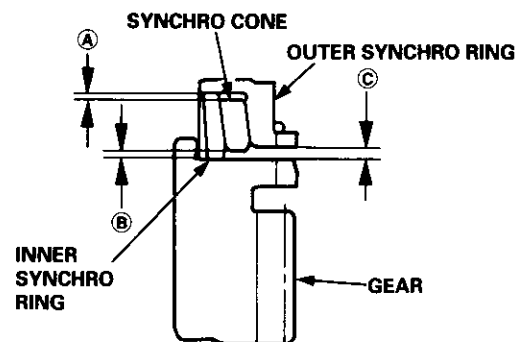
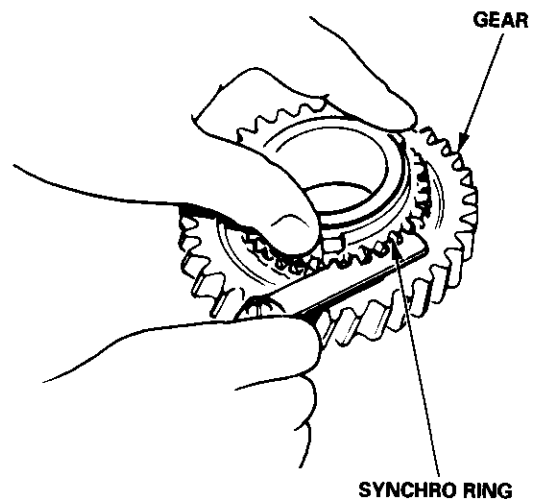
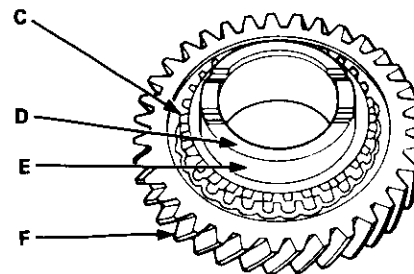
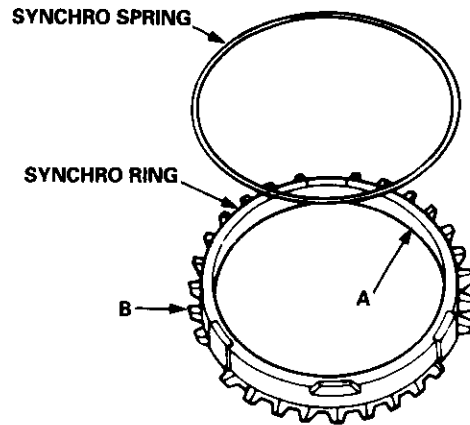

Mainshaft Bearing/Oil Seal

Replacement

1. Remove the differential assembly.
2. Remove the ball bearing with the special tool as shown.
3. Remove the oil seal from the clutch side.

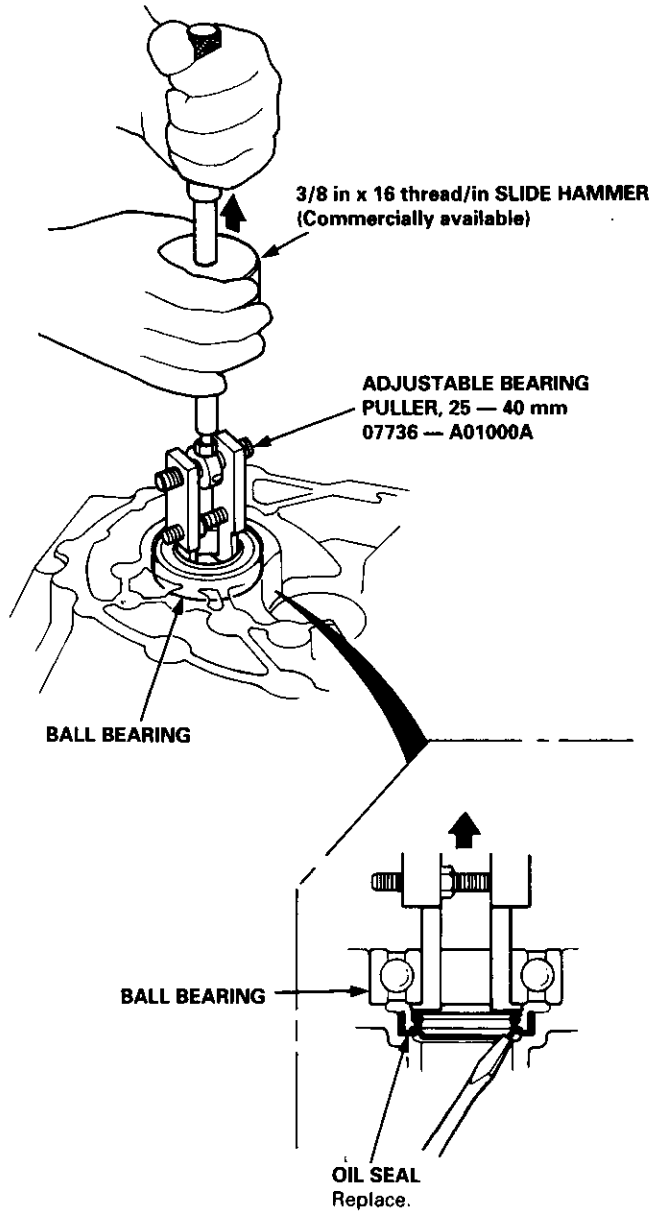

4. Drive the new oil seal in from the transmission side using the special tools as shown.

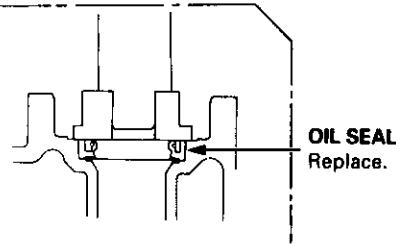
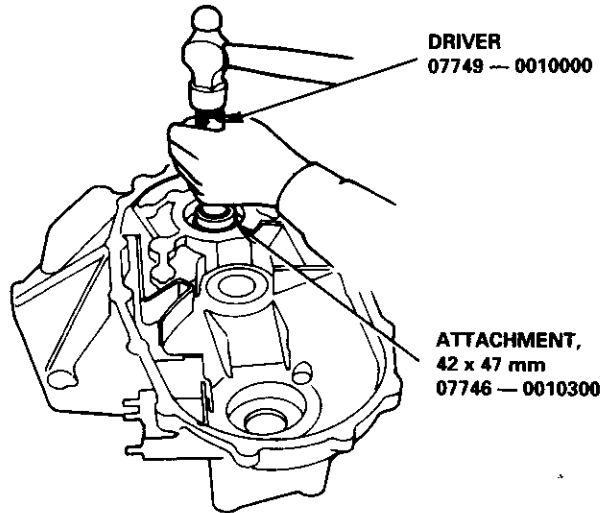

5. Drive the new ball bearing in from the transmission side using the special tools as shown.

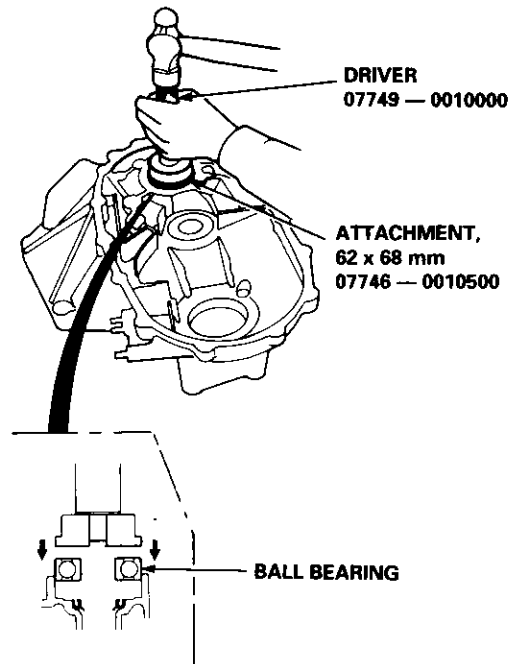



Countershaft Bearing

Replacement

1. Remove the retaining plate from the clutch housing.

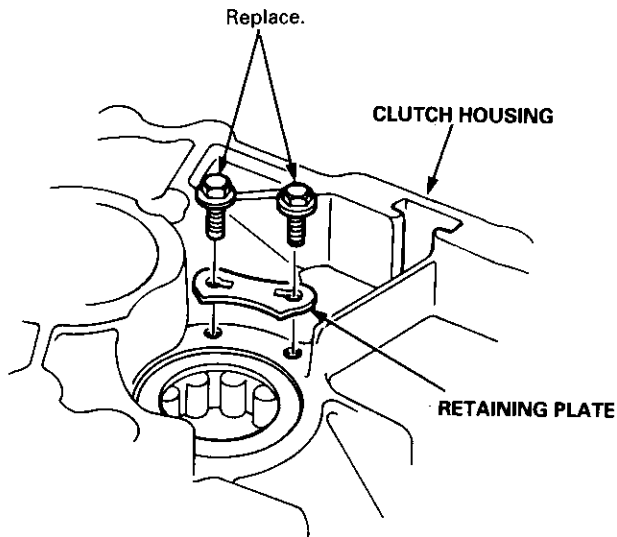

2. Remove the needle bearing with the special tool, then remove the oil guide plate.

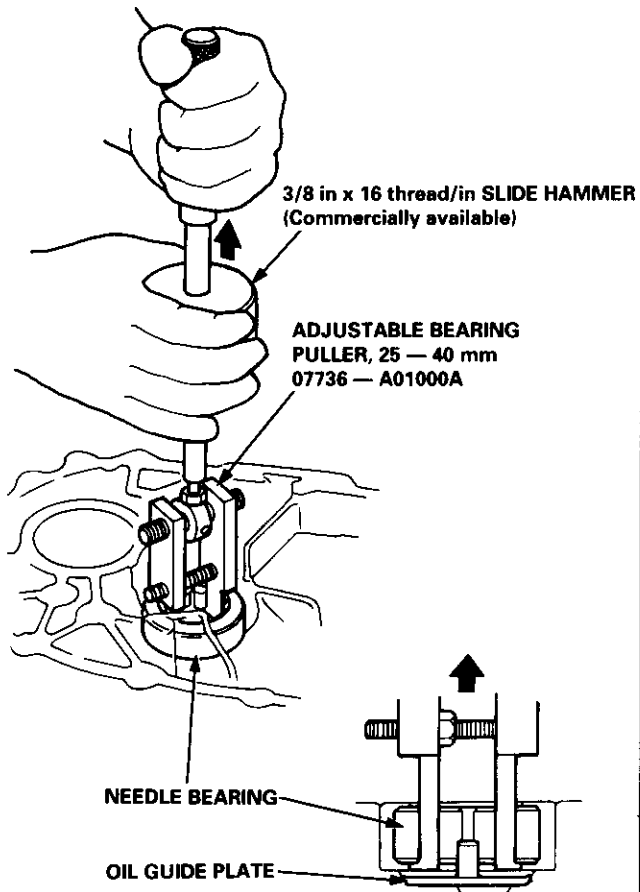

3. Position the oil guide plate and new needle bearing in the bore of the clutch housing.

NOTE: Position the needle bearing with the oil hole facing up.

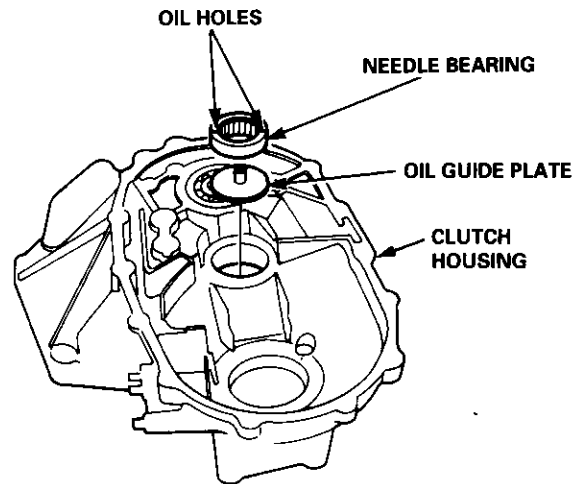

4. Drive the needle bearing in using the special tools as shown.

DRIVER
07749 - 0010000

ATTACHMENT,
62 x 68 mm
07746 - 0010500

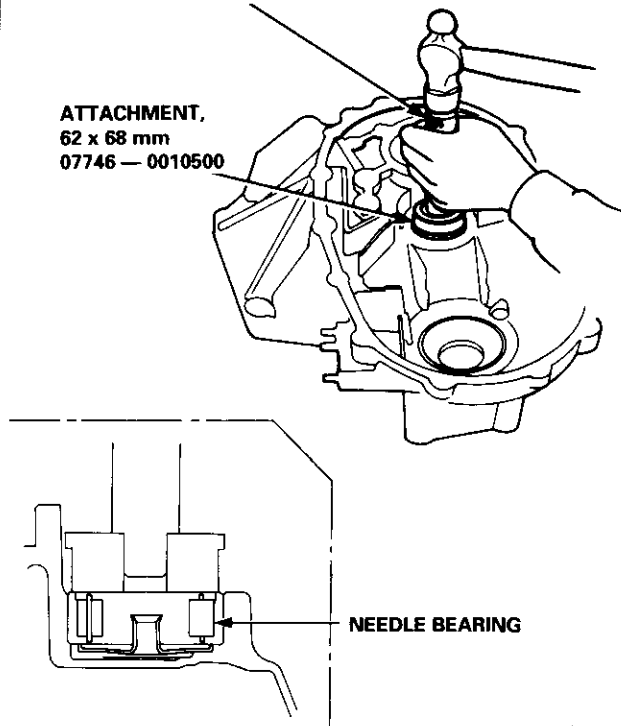

(cont'd)

Countershaft Bearing

Replacement (cont'd)

5. Install the retaining plate and stake the bolt heads in the groove in the retaining plate.

6 x 1.0 mm
12 N·m (1.2 kg-m, 9 lb-ft)
Replace.

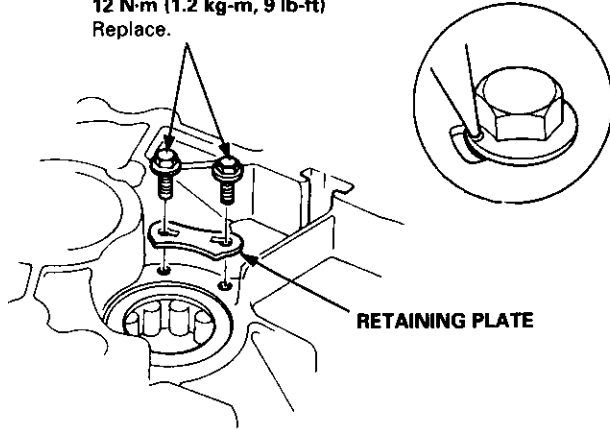

Mainshaft Thrust Shim

Adjustment

1. Remove the thrust shim and oil guide plate from the transmission housing.

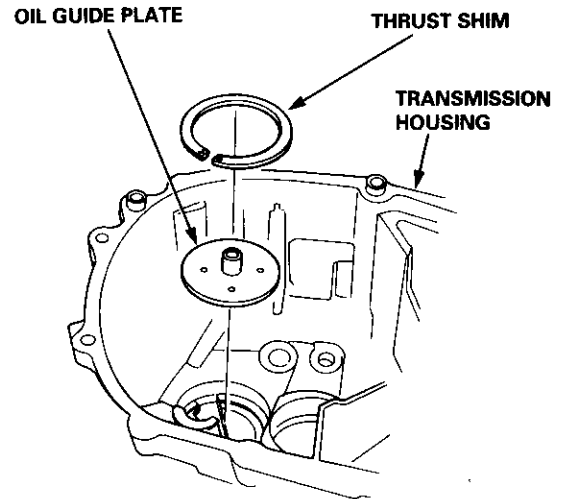

2. Install the 3rd/4th synchro hub, spacer collars, 5th synchro hub, and ball bearing on the mainshaft, then install the above assembly in the transmission housing.
3. Install the washer on the mainshaft.
4. Measure distance (B) between the end of the transmission housing and washer.

NOTE:

- Use a straight edge and vernier caliper.
- Measure at three locations and average the reading.

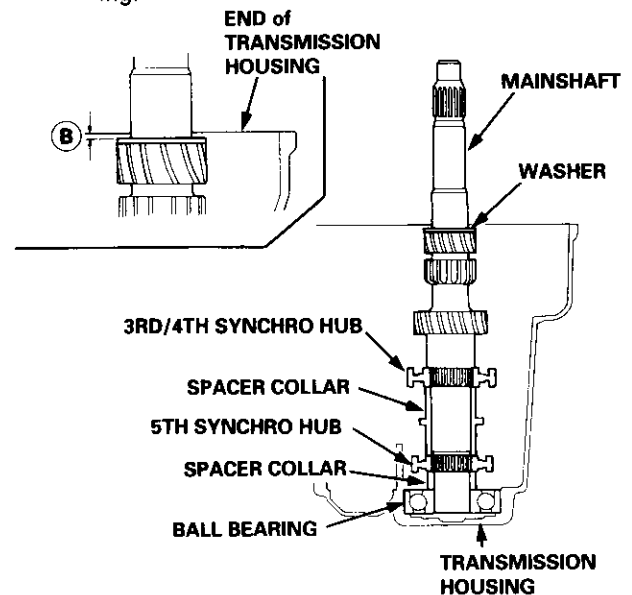



5. Measure distance © between the end of the clutch housing and bearing inner race.

NOTE:

- Use a straight edge and depth gauge.
- Measure at three locations and average the readings.

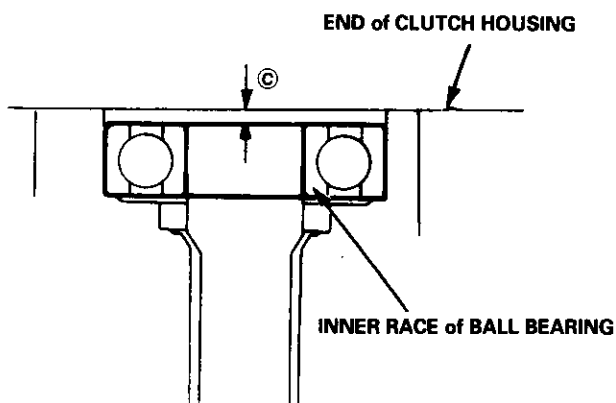

6. Select the proper thrust shim from the chart by using the formula below.

NOTE: Use only one thrust shim.

Shim Selection Formula:

From the measurements you made in steps 4 and 5:

- 1. Add distance © (step 5) to distance ⑥ (step 4).
- 2. From this number, subtract 0.93 (which is the midpoint of the flex range of the clutch housing bearing spring washer).
- 3. Take this number and compare it to the available shim sizes in the chart.

(For example)

$$\begin{array}{r}
 \text{B: } 2.39 \\
 + \text{ C: } 0.22 \\
 \hline
 = 2.61
 \end{array}
 \qquad
 \begin{array}{r}
 \nearrow \\
 \text{---} \\
 \text{---} \\
 \hline
 = 1.68
 \end{array}$$

- Try the 1.68 mm (0.0661 in) shim.

78 mm THRUST SHIM

	Part Number	Thickness
A	23941 — PK5 — 000	1.20 mm (0.0472 in)
B	23942 — PK5 — 000	1.23 mm (0.0484 in)
C	23943 — PK5 — 000	1.26 mm (0.0496 in)
D	23944 — PK5 — 000	1.29 mm (0.0508 in)
E	23945 — PK5 — 000	1.32 mm (0.0520 in)
F	23946 — PK5 — 000	1.35 mm (0.0531 in)
G	23947 — PK5 — 000	1.38 mm (0.0543 in)
H	23948 — PK5 — 000	1.41 mm (0.0555 in)
I	23949 — PK5 — 000	1.44 mm (0.0567 in)
J	23950 — PK5 — 000	1.47 mm (0.0579 in)
K	23951 — PK5 — 000	1.50 mm (0.0591 in)
L	23952 — PK5 — 000	1.53 mm (0.0602 in)
M	23953 — PK5 — 000	1.56 mm (0.0614 in)
N	23954 — PK5 — 000	1.59 mm (0.0626 in)
O	23955 — PK5 — 000	1.62 mm (0.0638 in)
P	23956 — PK5 — 000	1.65 mm (0.0650 in)
Q	23957 — PK5 — 000	1.68 mm (0.0661 in)
R	23958 — PK5 — 000	1.71 mm (0.0673 in)
S	23959 — PK5 — 000	1.74 mm (0.0685 in)
T	23960 — PK5 — 000	1.77 mm (0.0697 in)
U	23961 — PK5 — 000	1.80 mm (0.0709 in)
V	23962 — PK5 — 000	1.83 mm (0.0720 in)
W	23963 — PK5 — 000	1.86 mm (0.0732 in)
X	23964 — PK5 — 000	1.89 mm (0.0744 in)
Y	23965 — PK5 — 000	1.92 mm (0.0756 in)
Z	23966 — PK5 — 000	1.95 mm (0.0768 in)
AA	23967 — PK5 — 000	1.98 mm (0.0780 in)
AB	23968 — PK5 — 000	2.01 mm (0.0791 in)
AC	23969 — PK5 — 000	2.04 mm (0.0803 in)
AD	23970 — PK5 — 000	2.07 mm (0.0815 in)
AE	23971 — PK5 — 000	2.10 mm (0.0827 in)
AF	23972 — PK5 — 000	2.13 mm (0.0839 in)
AG	23973 — PK5 — 000	2.16 mm (0.0850 in)
AH	23974 — PK5 — 000	2.19 mm (0.0862 in)
AI	23975 — PK5 — 000	2.22 mm (0.0874 in)
AJ	23976 — PK5 — 000	2.25 mm (0.0886 in)
AK	23977 — PK5 — 000	2.28 mm (0.0898 in)
AL	23978 — PK5 — 000	2.31 mm (0.0909 in)
AM	23979 — PK5 — 000	2.34 mm (0.0921 in)
AN	23980 — PK5 — 000	2.37 mm (0.0933 in)

(cont'd)

Mainshaft Thrust Shim

Adjustment (cont'd)

7. Check the thrust clearance in the manner described below.

NOTE: Carry out the measurement at normal room temperature.

- 1. Install the thrust shim selected and oil guide plate in the transmission housing.

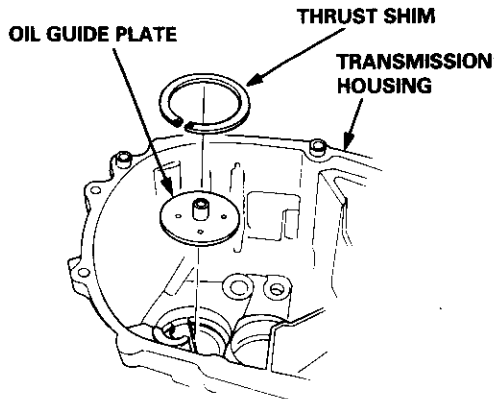

- 2. Install the spring washer and washer on the ball bearing.

NOTE:

- Clean the spring washer, washer and thrust shim thoroughly before installation.
- Install the spring washer, washer and thrust shim properly.

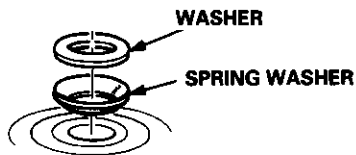

- 3. Install the mainshaft in the clutch housing.
- 4. Place the transmission housing over the mainshaft and onto the clutch housing.
- 5. Tighten the clutch and transmission housings with several 8 mm and 10 mm bolts.
- 6. Tap the mainshaft with a plastic hammer.

- 7. Slide the mainshaft base over the mainshaft.

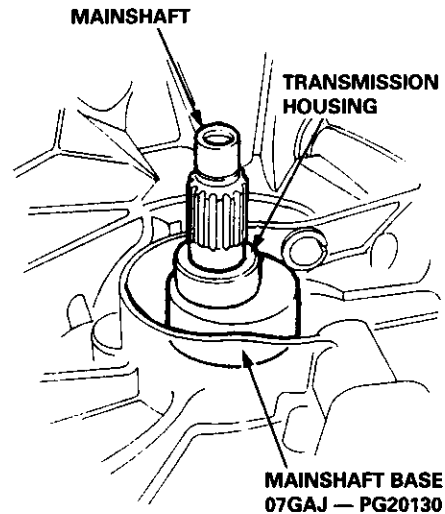

- 8. Attach the mainshaft holder to the mainshaft as follows:

NOTE:

- Back-out the mainshaft holder bolt and loosen the two hex bolts.
- Fit the holder over the mainshaft so its lip is towards the transmission.
- Align the mainshaft holder's lip around the groove at the inside of the mainshaft splines, then tighten the hex bolts.

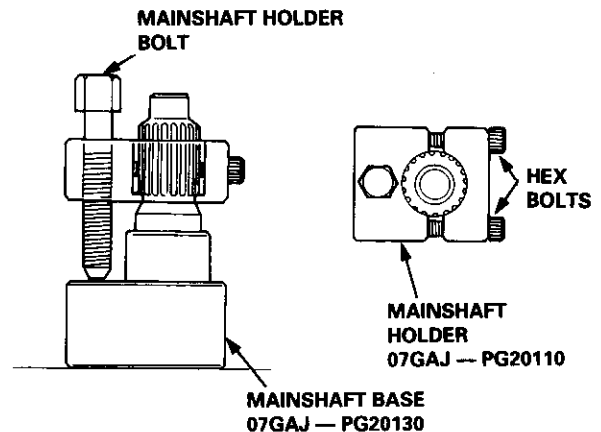

- 9. Seat the mainshaft fully by tapping its end with a plastic hammer.
- 10. Thread the mainshaft holder bolt in until it just contacts the wide surface of the mainshaft base.
- 11. Zero a dial gauge on the end of the mainshaft.



Transmission

Reassembly

- 12. Turn the mainshaft holder bolt clockwise; stop turning when the dial gauge has reached its maximum movement. The reading on the dial gauge is the amount of mainshaft end play.

CAUTION: Turning the mainshaft holder bolt more than 60 degrees after the needle of the dial gauge stops moving may damage the transmission.

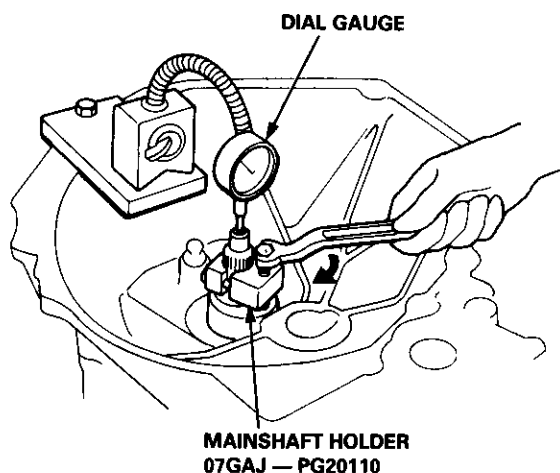

- 13. If the reading is within the standard, the clearance is correct.
If the reading is not within the standard, recheck the shim thickness.

Standard: 0.10 — 0.16 mm (0.004 — 0.006 in)

1. Install the differential assembly in the clutch housing.

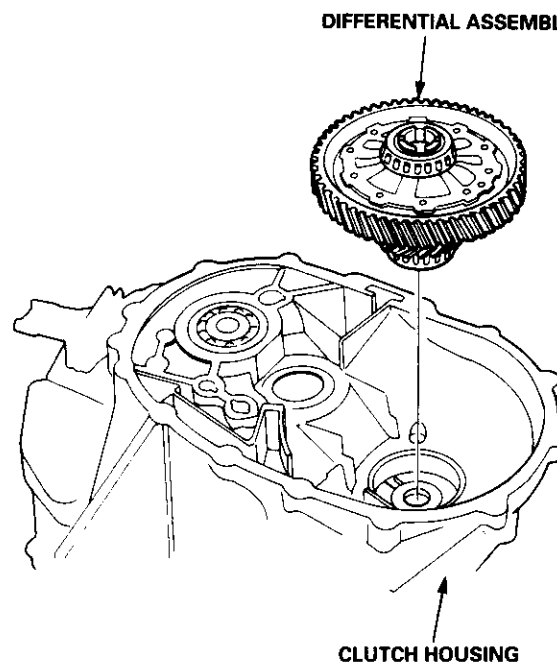

2. Install the spring washer and washer with the angle against the clutch housing as shown.
3. Insert the mainshaft and countershaft into the shift forks and install them as an assembly.

NOTE: Before installing the mainshaft and countershaft assemblies, tape the mainshaft splines to protect them.

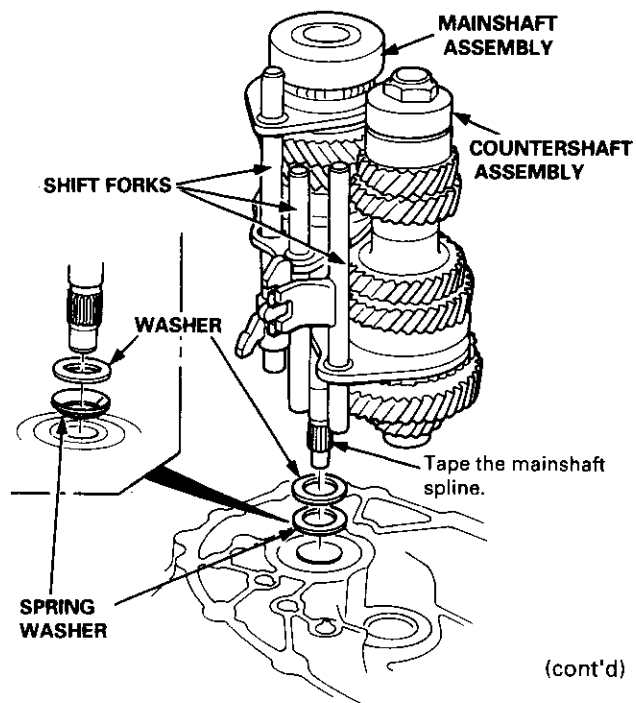

(cont'd)

Transmission

Reassembly (cont'd)

4. Install the reverse idler gear and reverse idler gear shaft in the clutch housing.

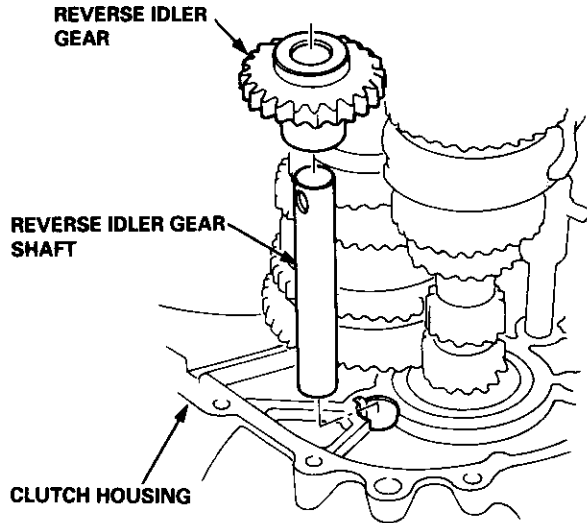

5. Install the reverse shift fork in the clutch housing with the 5th/reverse shift piece pin positioned in the slot of the reverse shift fork.

NOTE: Check that the steel ball is in the proper position.

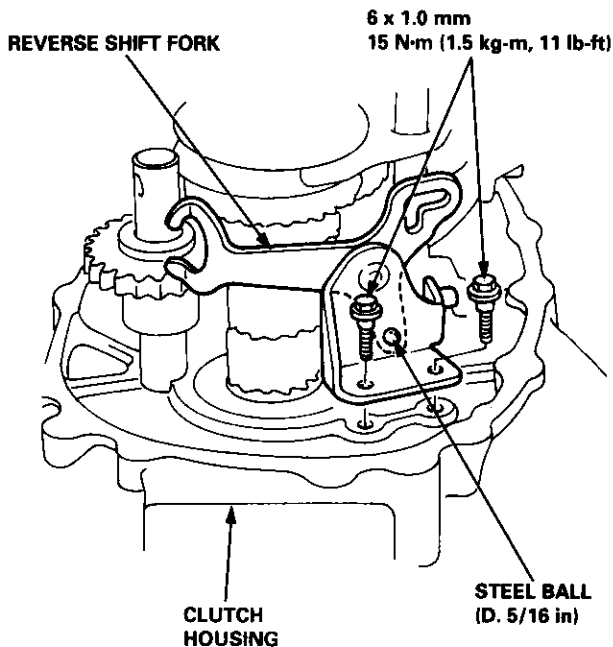

NOTE: Select the thrust shim according to the measurements made on page 13-34.

6. Install the oil guide plate and thrust shim into the transmission housing.

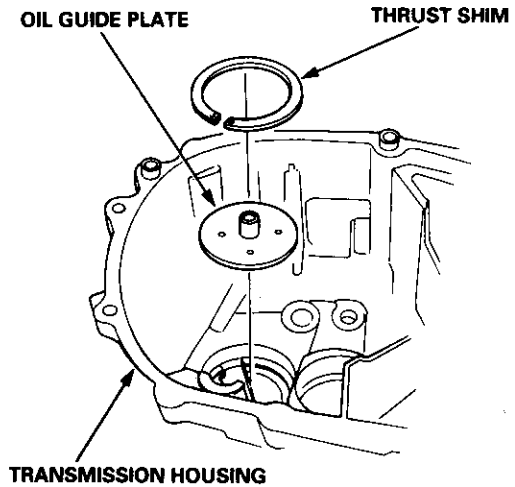

7. Install the oil gutter plate in the transmission housing.

NOTE: Bend the hook of the oil gutter plate into the hole on the transmission housing.

8. Install the 28 mm sealing bolt.

NOTE: Apply liquid gasket (P/N 08718 — 0001) to the threads.

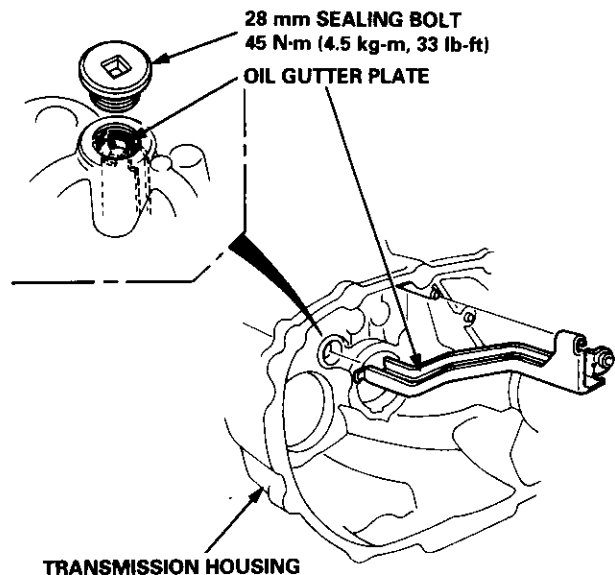



9. Apply liquid gasket to the clutch housing mating surface as shown.

NOTE:

- Use liquid gasket (P/N 08718 — 0001).
- Remove the dirt oil from the sealing surface.
- Seal the entire circumference of the bolt hole to prevent oil leakage.
- If 20 minutes have passed after applying liquid gasket, reapply it and assemble the housings and allow it to cure at least 30 minutes after assembly before filling transmission with oil.

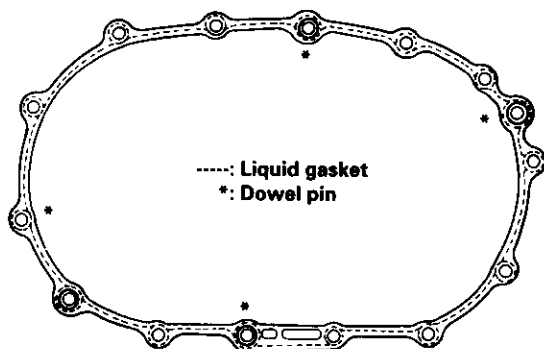

10. Install the 14 x 20 mm dowel pins.

11. Set the stopper ring as shown. Place the transmission housing over the clutch housing, being careful to line up the shafts.

NOTE: Align the long arm of 5th shift fork with the hook on the stopper ring.

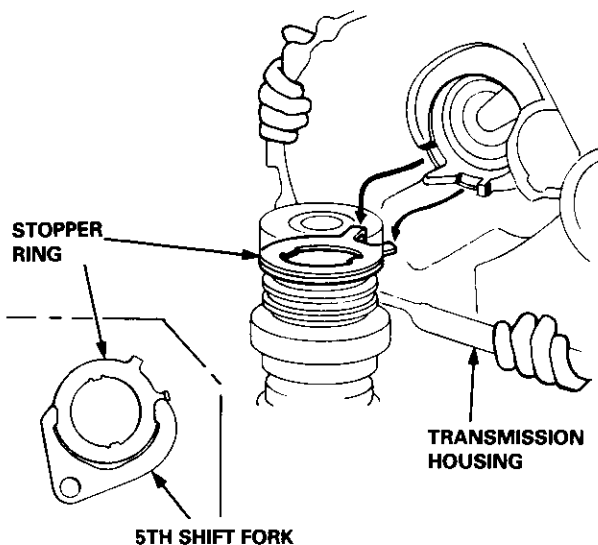

12. Lower the transmission housing with the snap ring pliers and set the snap ring in the groove of the countershaft bearing.

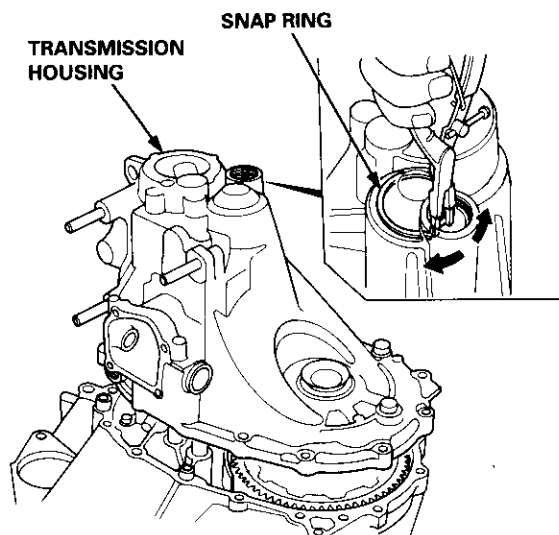

13. Check that the snap ring is securely seated in the groove of the countershaft bearing.

**Dimension A as installed: 3.60 — 6.32 mm
(0.142 — 0.249 in)**

14. Install the 32 mm sealing bolt.

NOTE: Apply liquid gasket (P/N 08718 — 0001) to the threads.

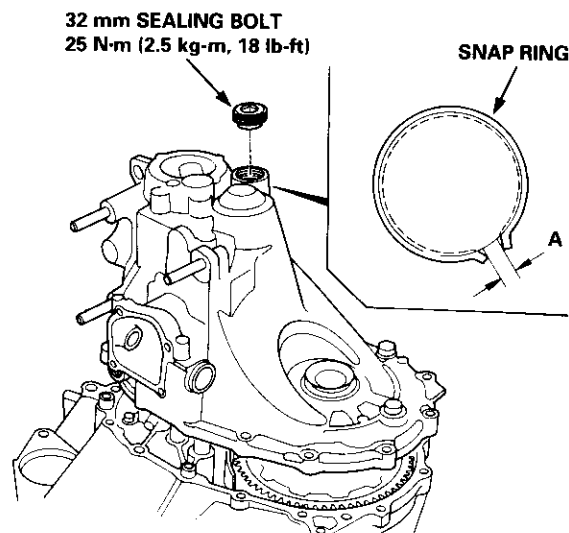

(cont'd)

Transmission

Reassembly (cont'd)

- Torque the bolts in a crisscross pattern in several steps as shown.

8 x 1.25 mm bolts: 28 N·m (2.8 kg-m, 20 lb-ft)

10 x 1.25 mm bolts: 45 N·m (4.5 kg-m, 33 lb-ft)

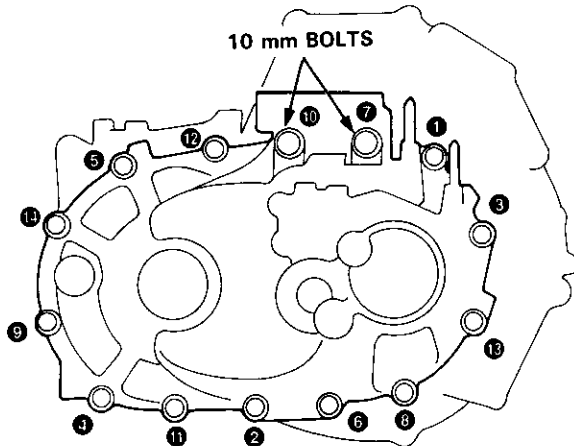

② ④: 8 x 50 mm bolts
Other: 8 x 40 mm bolts

- Install the reverse idler gear shaft bolt.
- Install the steel balls, springs, washers and setting screws.

STEEL BALL (D. 5/16 in)

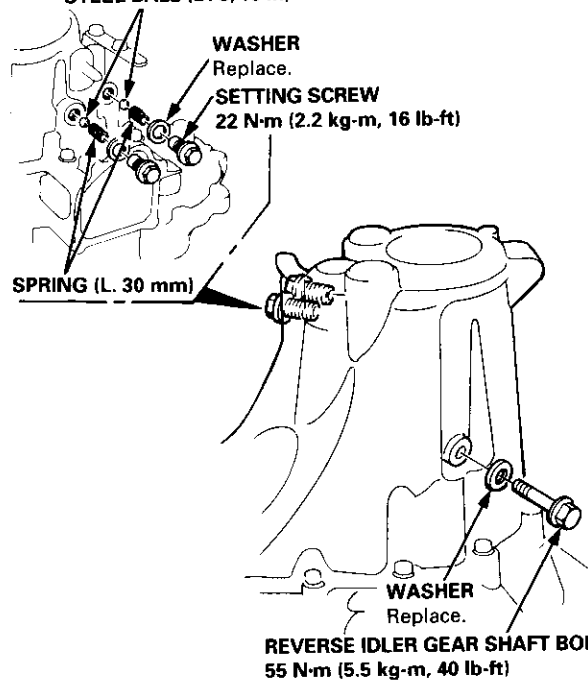

- Install the shift arm cover assembly (see page 13-13).
- Shift the transmission through all the gears before installing it.

Transmission Assembly

Installation

- Install the dowel pins.

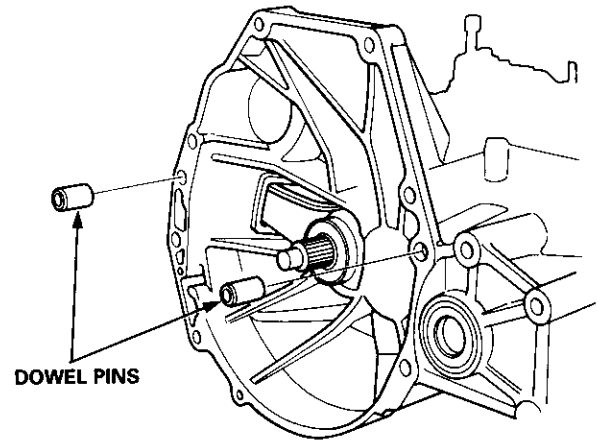

- Apply grease to the parts as shown, then install the release bearing and release fork (see page 12-7).

NOTE: Use only Super High Temp Urea Grease (P/N 08798 — 9002).

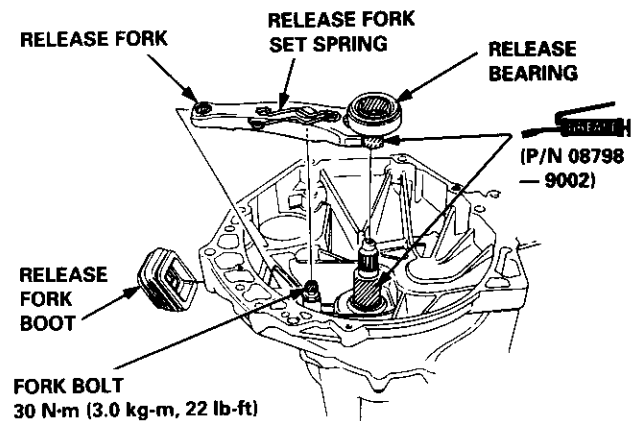

- Install the release fork boot.



4. Place the transmission on the transmission jack, and raise it to the engine level.
5. Install the three lower transmission mounting bolts.

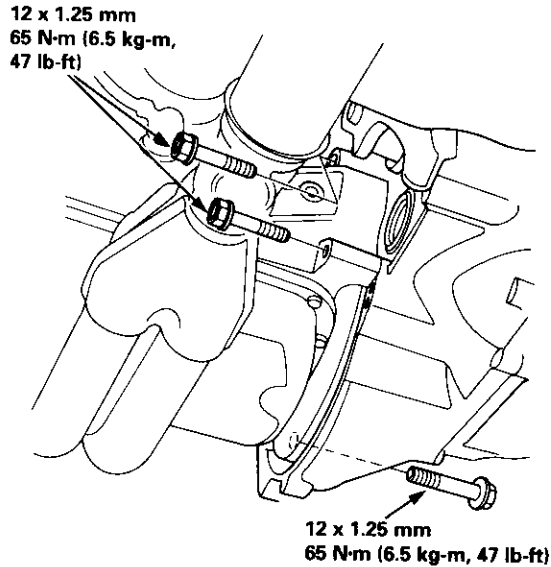

6. Install the two upper transmission mounting bolts.

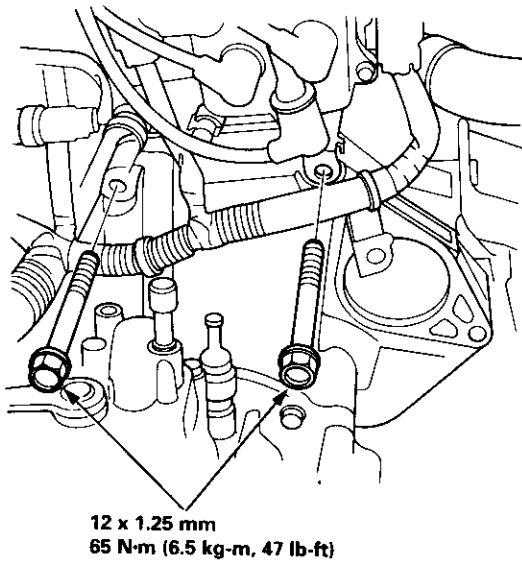

7. Raise the transmission, then install the mount bracket and transmission mount.

NOTE:

- Torque mounting bolts and nuts in sequence shown.
- Make sure the bushings are not twisted or offset.

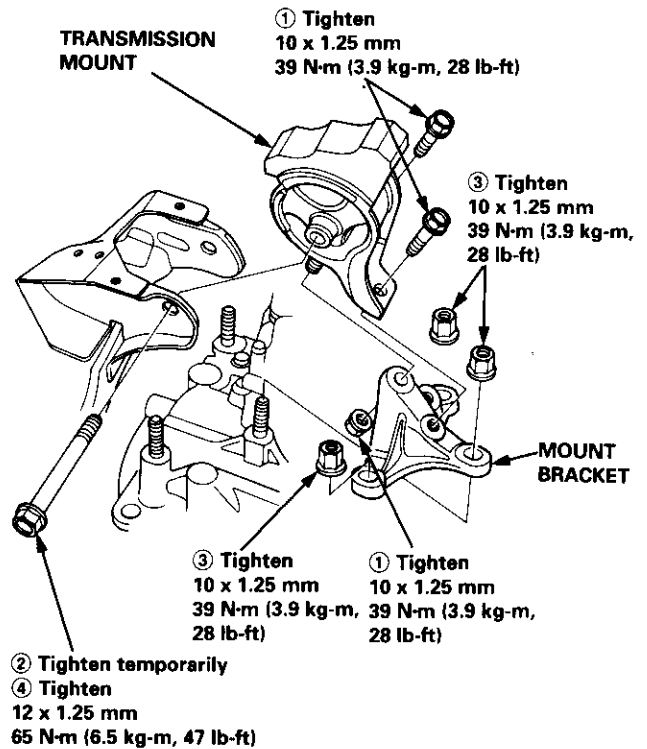

8. Install the three rear engine mount bracket mounting bolts.

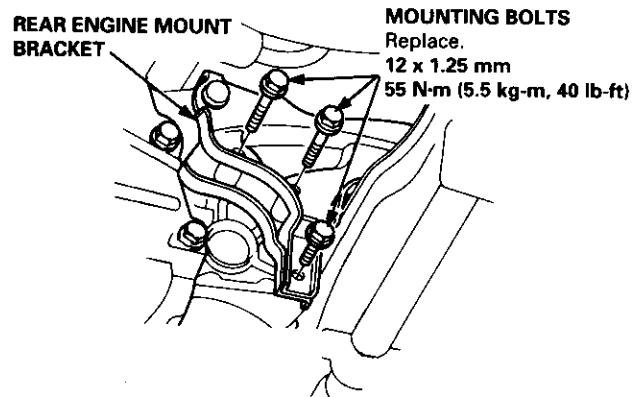

(cont'd)

Transmission Assembly

Installation (cont'd)

9. Install the rear beam stiffener.

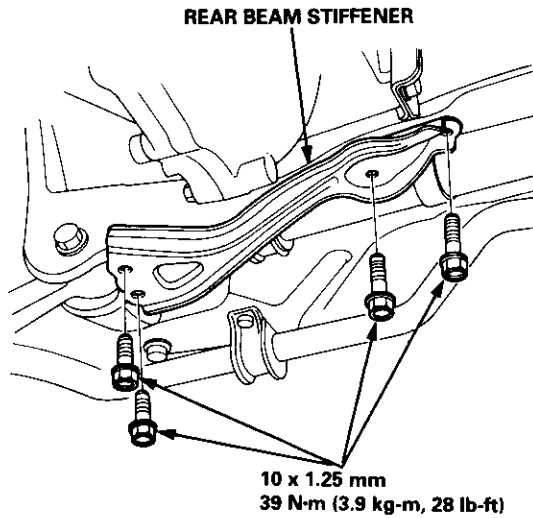

10. Install the intake manifold stay.

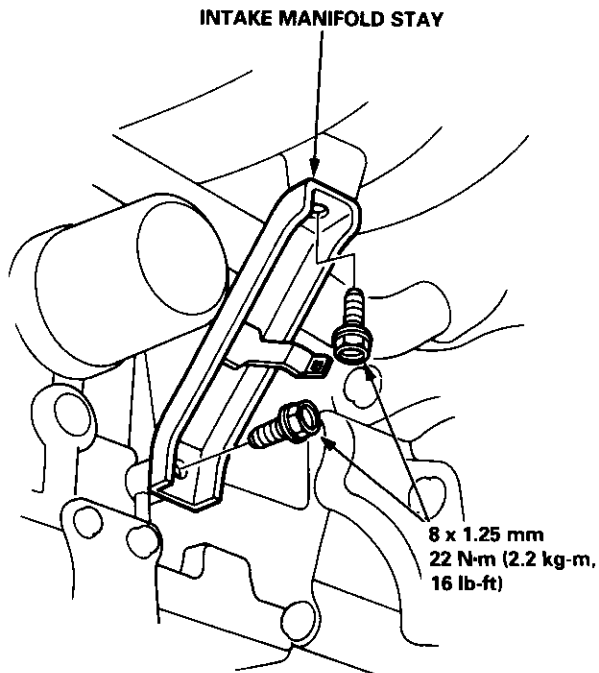

11. Install the front engine stiffener and clutch cover.

NOTE: Torque the front engine stiffener mounting bolts following the numbered sequence.

Torque: 39 N-m (3.9 kg-m, 28 lb-ft)

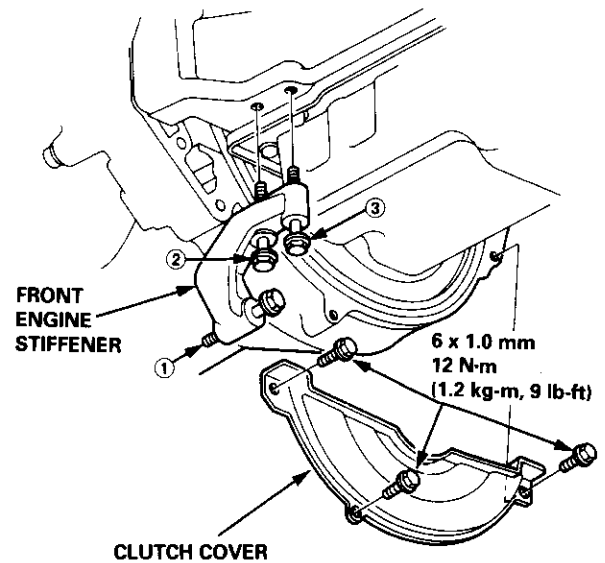

12. Install the center beam.

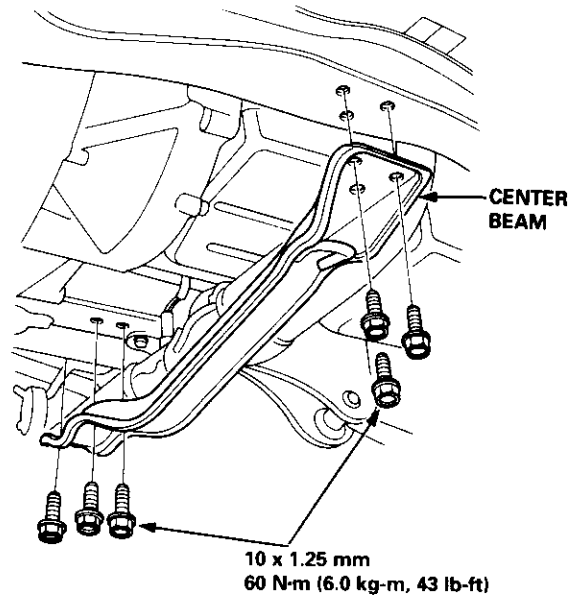



13. Install the intermediate shaft and driveshafts (see section 16).

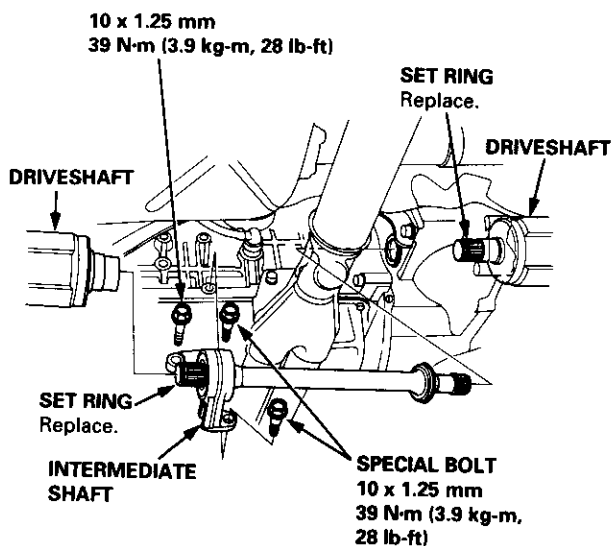

14. Install the radius rod.

NOTE: Check for deterioration or damage of the radius rod rubber bushings.

15. Connect the ball joint to the lower arm, then install the ball joint nut.

16. Install the damper fork bolt.

SELF-LOCKING BOLTS
Replace.

12 x 1.25 mm
105 N-m (10.5 kg-m, 76 lb-ft)

SELF-LOCKING NUT
Replace.

12 x 1.25 mm
55 N-m (5.5 kg-m, 40 lb-ft)

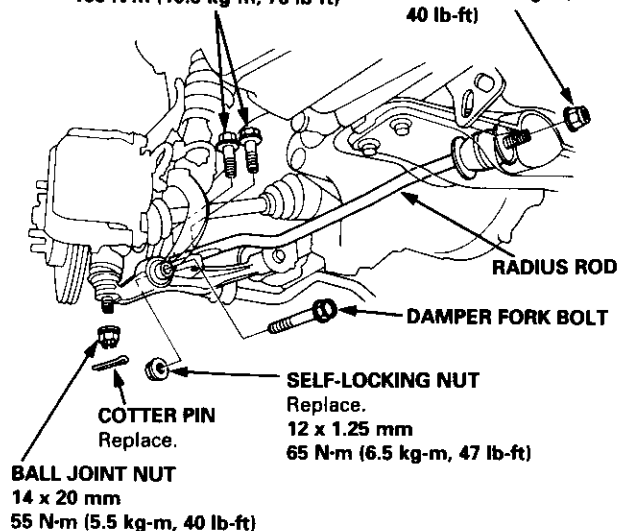

17. Install the rear engine mount bracket stay.

NOTE: Loosely install the stay mounting bolt and nut, then torque in the sequence shown.

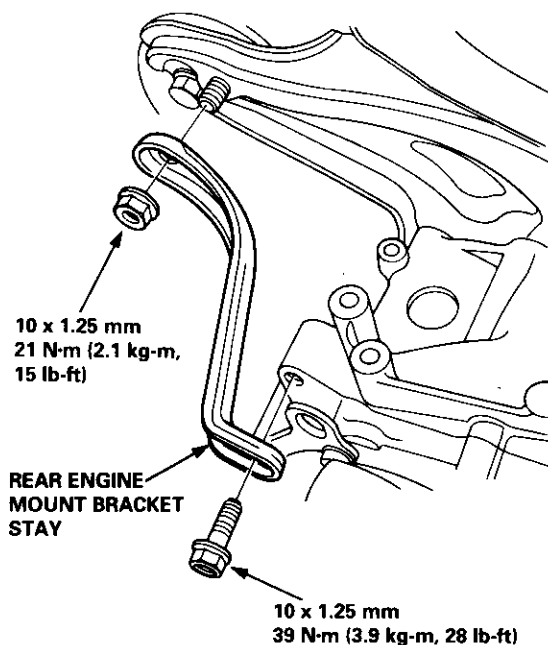

18. Install the clutch damper.

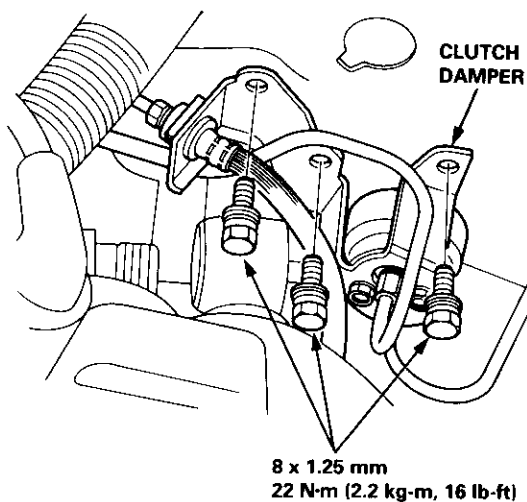

(cont'd)

Transmission Assembly

Installation (cont'd)

19. Install the slave cylinder, then install the clutch pipe joint and stay.

CAUTION: Take care not to bend the clutch pipe.

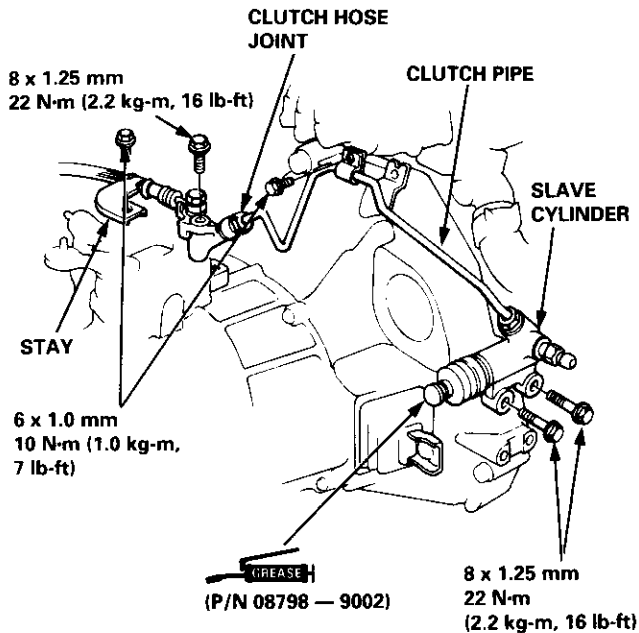

20. Install the vehicle speed sensor (VSS)/power steering speed sensor, then connect the VSS connector.

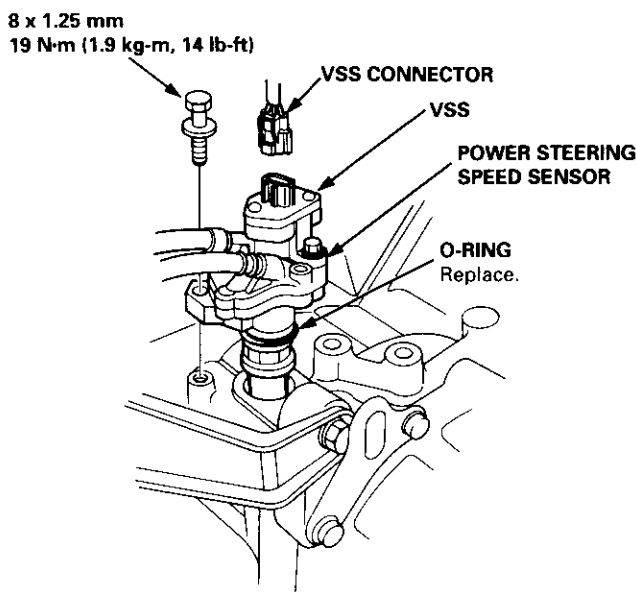

21. Install the shift cable and select cable to the shift lever and to select lever respectively.

CAUTION: Take care not to bend the cables.

NOTE:

- Check that the new cotter pin is seated firmly.
- Turn the boot of the shift lever so the hole is facing down.

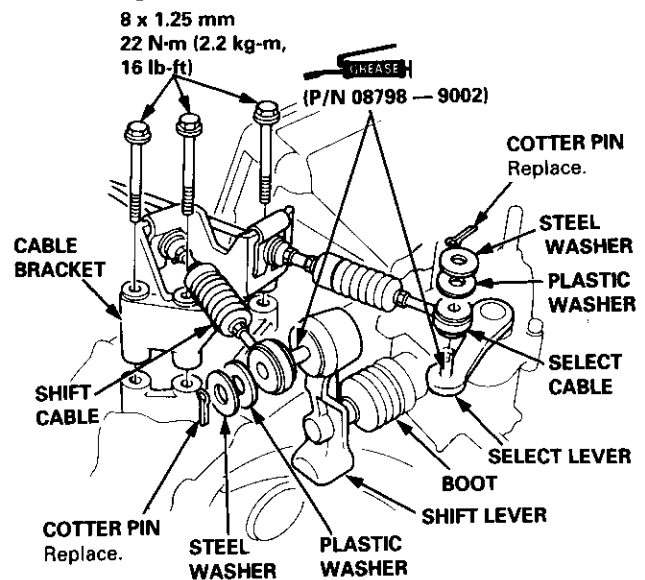

22. Connect the transmission ground cable and back-up light switch connectors.

23. Install the wire harness clamp.

24. Install the starter motor, then connect the starter motor cables.

NOTE: When installing the starter motor cable, make sure that the crimped side of the ring terminal is facing out (see section 23).

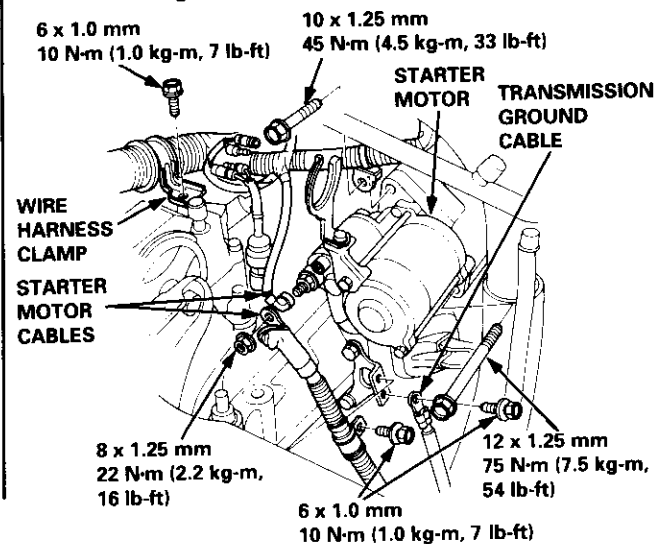



25. Install the bracket and intake control vacuum tank.

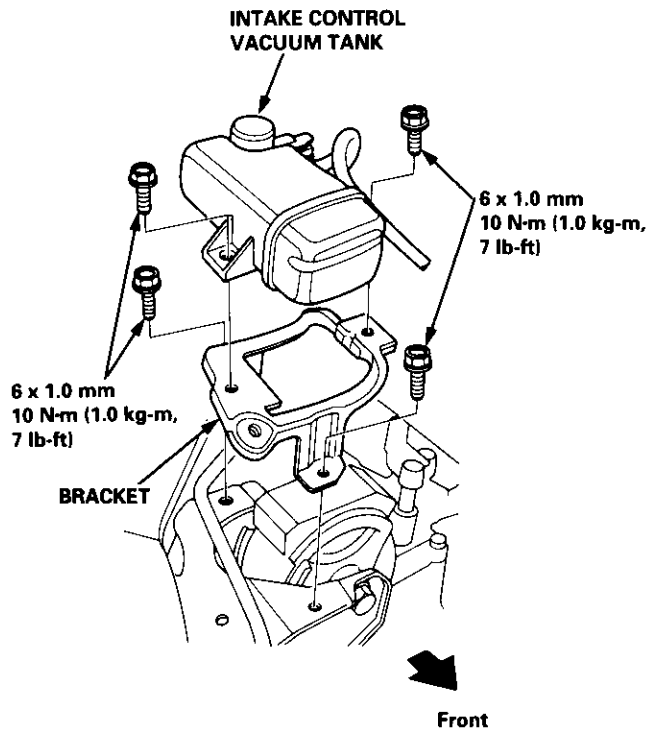

26. Install the air cleaner assembly and intake air duct.

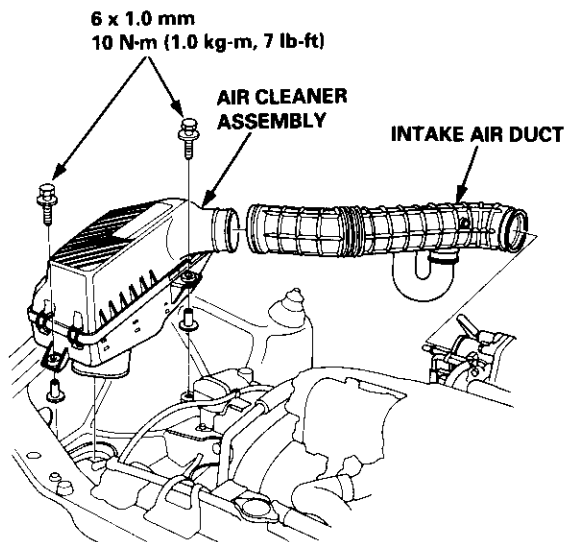

27. Install the base stay and battery base.

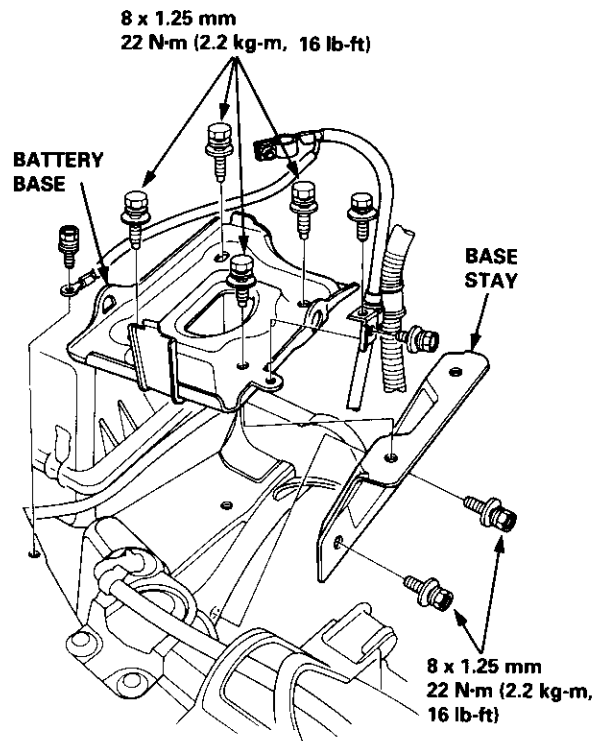

28. Refill the transmission with oil (see page 13-2).

29. Install the battery, then connect the battery positive (+) and negative (-) cables to the battery.

30. Check the clutch operation.

31. Shift the transmission and check for smooth operation.

32. Check the front wheel alignment (see section 18).

(cont'd)

Transmission Assembly

Installation (cont'd)

33. Loosen the three mounting bolts of the front engine mount bracket, then torque the three mounting bolts.

NOTE: Make sure the bushings are not twisted or offset.

FRONT ENGINE MOUNT BRACKET

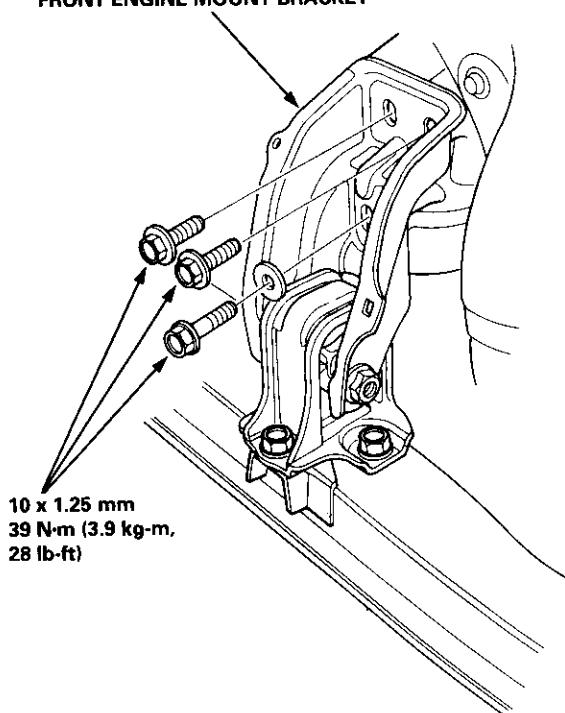

10 x 1.25 mm
39 N·m (3.9 kg-m,
28 lb-ft)

Automatic Transmission

Special Tools	14-2	Oil Pump	
Description	14-3	Inspection	14-101
Clutches	14-6	Main Valve Body	
Power Flow	14-9	Disassembly/Inspection/Reassembly	14-102
Electrical Control System	14-10	Secondary Valve Body	
Hydraulic Flow	14-13	Disassembly/Inspection/Reassembly	14-104
Lock-up System	14-22	Regulator Valve Body	
Hydraulic Control	14-28	Disassembly/Inspection/Reassembly	14-106
Electrical System		Throttle Valve Body	
Component Location	14-31	Disassembly/Inspection/Reassembly	14-107
Circuit Diagram	14-32	Servo Body	
* Troubleshooting Procedures	14-34	Disassembly/Inspection/Reassembly	14-108
Symptom-to-Component Chart		1st/2nd Accumulator Body	
Electrical System	14-36	Disassembly/Inspection/Reassembly	14-109
Electrical Troubleshooting		Mainshaft	
Troubleshooting Flowchart	14-38	Disassembly/Inspection/Reassembly	14-110
Mainshaft/Countershaft Speed Sensors		Countershaft	
Replacement	14-61	Disassembly/Inspection/Reassembly	14-111
Lock-up Control Solenoid Valve A/B		Removal	14-112
Test	14-62	Installation	14-113
Replacement	14-62	One-way Clutch	
Shift Control Solenoid Valve A/B		Disassembly/Inspection/Reassembly	14-114
Test	14-63	Secondary Shaft	
Replacement	14-63	Disassembly/Inspection/Reassembly	14-115
Hydraulic System		Inspection	14-116
Symptom-to-Component Chart		Clutch	
Hydraulic System	14-64	Illustrated Index	14-117
* Road Test	14-68	Disassembly	14-121
Stall Speed		Reassembly	14-123
Test	14-71	Torque Converter Housing Bearings	
Fluid Level		Mainshaft Bearing/Oil Seal	
Checking/Changing	14-72	Replacement	14-127
Pressure Testing	14-73	Countershaft Bearing Replacement	14-128
Transmission		Secondary Shaft Bearing Replacement	14-128
Transmission		Transmission Housing Bearings	
Removal	14-80	Removal/Installation	14-129
Illustrated Index		Transmission	
Right Side Cover	14-86	Reassembly	14-130
Transmission Housing	14-88	Right Side Cover	
Torque Converter Housing	14-90	Feed Pipe Installation	14-136
Right Side Cover		Parking Brake Stopper	
Removal	14-92	Inspection/Adjustment	14-136
Transmission Housing		Torque Converter	
Removal	14-94	Disassembly	14-137
Torque Converter Housing/Valve Body		Transmission	
Removal	14-96	Installation	14-138
Valve Body		Cooler Flushing	14-142
Repair	14-98	Shift Cable	
Valve		* Removal/Installation	14-144
Assembly	14-99	* Adjustment	14-146
Valve Caps		* Gearshift Selector	14-147
Description	14-100	A/T Gear Position Indicator Panel	
		* Adjustment	14-148
		Throttle Control Cable	
		Inspection	14-149
		Adjustment	14-150

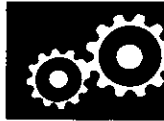

Special Tools

Ref. No.	Tool Number	Description	Qty	Page Reference
①	07GAB—PF50100 or 07GAB—PF50101	Mainshaft Holder	1	14-92, 134
②	07GAE—PG40200	Clutch Spring Compressor Bolt Assembly	1	14-121, 124
③	07HAC—PK4010A	Housing Puller	1	14-93
④	07HAE—PL50100	Clutch Spring Compressor Attachment	1	14-121, 124
⑤	07LAE—PX40100	Clutch Spring Compressor Attachment	1	14-121, 124
⑥	07LAJ—PT3010A	Test Harness	1	14-35, 68
⑦	07406—0020201	A/T Oil Pressure Hose (Replacement Hoses)	1	14-73
⑧	07406—0020003	A/T Oil Pressure Gauge Set	1	14-73
⑨	07406—0070000	A/T Low Pressure Gauge	1	14-73
*⑩	07736—A01000A	Adjustable Bearing Puller, 25—40 mm	1	14-128
⑪	07746—0010400	Attachment, 52 x 55 mm	1	14-128
⑫	07746—0010500	Attachment, 62 x 68 mm	1	14-127, 128
⑬	07746—0010600	Attachment, 72 x 75 mm	1	14-127
⑭	07749—0010000	Driver	1	14-127, 128
⑮	07947—6340500	Attachment	1	14-127
⑯	J38405—A	Transmission Cooler Flusher	1	14-142

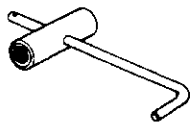

①



②

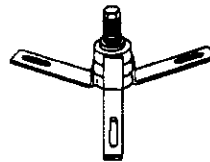

③

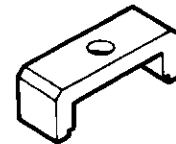

④

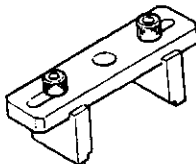

⑤

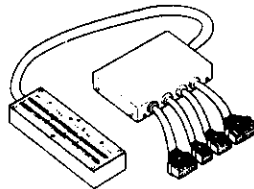

⑥

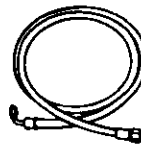

⑦

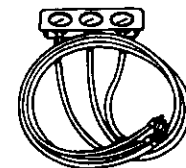

⑧

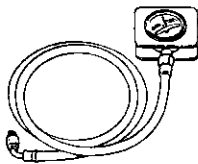

⑨

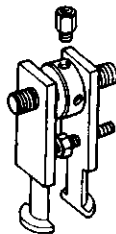

⑩



⑪

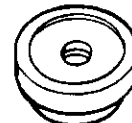

⑫

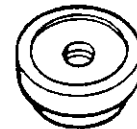

⑬

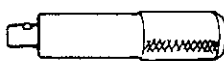

⑭

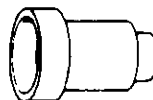

⑮

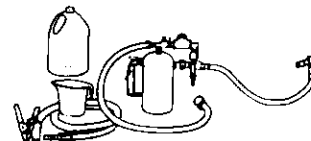

⑯

*⑩ Must be used with commercially available 3/8 in. x 16 threads/in. slide hammer.

Description



The Automatic Transmission is a combination of a 3-element torque converter and triple-shaft electronically controlled automatic transmission which provides 4 speeds forward and 1 speed reverse. The entire unit is positioned in line with the engine.

Torque Converter, Gears and Clutches

The torque converter consists of a pump, turbine and stator assembled in a single unit.

They are connected to the engine crankshaft so they turn together as a unit as the engine turns. Around the outside of the torque converter is a ring gear which meshes with the starter pinion when the engine is being started. The entire torque converter assembly serves as a flywheel while transmitting power to the transmission mainshaft.

The transmission has three parallel shafts: the mainshaft, the countershaft, and the secondary shaft. The mainshaft is in line with the engine crankshaft.

The mainshaft includes the clutches for 3rd, and 4th, and gears for 3rd, 4th, Reverse and Idler (Reverse gear is integral with 4th gear).

The countershaft includes the 1st-hold clutch and gears for 2nd, 3rd, 4th, Reverse, 1st and Idler.

The secondary shaft includes the 1st and 2nd clutches, and gears for 2nd, 1st and Idler.

The 4th and reverse gears can be locked to the countershaft at its center, providing 4th gear or Reverse, depending on which way the selector is moved.

The gears on the mainshaft are in constant mesh with those on the countershaft and the secondary shaft. When certain combinations of gears in the transmission are engaged by the clutches, power is transmitted from the mainshaft to the countershaft to provide **D₄**, **D₃**, **2**, **1** and **R** positions.

Electronic Control

The electronic control system consists of the Transmission Control Module (TCM), sensors, and 4 solenoid valves. Shifting and lock-up are electronically controlled for comfortable driving under all conditions.

The TCM is located below the dashboard, behind the right side kick panel on the passenger's side.

Hydraulic Control

The valve bodies include the main valve body, secondary valve body, servo body, regulator valve body, throttle valve body and 1st/2nd accumulator body. They are bolted to the torque converter housing as an assembly.

The main valve body contains the manual valve, 1-2 shift valve, 2-3 shift valve, cooler relief valve, lock-up shift valve, lock-up control valve, 3-2 kick-down valve, modulator valve, CPC valve and oil pump gears.

The secondary valve body includes the 4th exhaust valve, 3rd kick-down valve, 3-4 shift valve, servo control valve, orifice control valve and the 2nd orifice control valve.

The servo body contains the accumulator pistons and servo valve. The regulator valve body contains the regulator valve, torque converter check valve, and lock-up timing valve. The throttle valve body contains the throttle valve B and relief valve. Fluid from the regulator passes through the manual valve to the various control valves.

The clutches receive oil from their respective feed pipes or internal hydraulic circuit.

Shift Control Mechanism

Input from various sensors located throughout the car determines which shift control solenoid valve the TCM will activate. Activating a shift control solenoid valve changes modulator pressure, causing a shift valve to move. This pressurizes a line to one of the clutches, engaging that clutch and its corresponding gear.

Lock-up Mechanism

In **D₄** position, in 2nd, 3rd and 4th, and **D₃** position in 3rd, pressurized fluid is drained from the back of the torque converter through an oil passage, causing the lock-up piston to be held against the torque converter cover. As this takes place, the mainshaft rotates at the same speed as the engine crankshaft. Together with hydraulic control, the TCM optimizes the timing of the lock-up mechanism.

The lock-up valves control the range of lock-up according to lock-up control solenoid valves A and B, and throttle valve B.

When lock-up control solenoid valves A and B activate, modulator pressure changes. Lock-up control solenoid valves A and B are mounted on the torque converter housing, and are controlled by the TCM.

(cont'd)

Description

(cont'd)

Gear Selection

The selector lever has seven positions: **P** PARK, **R** REVERSE, **N** NEUTRAL, **D4** 1st through 4th gear ranges, **D3** 1st through 3rd gear ranges, **2** 2nd gear and **1** 1st gear.

Position	Description
P PARK	Front wheels locked; parking pawl engaged with parking gear on countershaft. All clutches released.
R REVERSE	Reverse; reverse selector engaged with countershaft reverse gear and 4th gear clutch locked.
N NEUTRAL	All clutches released.
D4 DRIVE (1st through 4th)	General driving; starts off in 1st, shifts automatically to 2nd, 3rd, then 4th, depending on vehicle speed and throttle position. Downshift through 3rd, 2nd and 1st on deceleration to stop. The lock-up mechanism comes into operation in D4 position in 2nd, 3rd and 4th speed.
D3 DRIVE (1st through 3rd)	For rapid acceleration at highway speeds and general driving; up-hill and down-hill driving; starts off in 1st, shifts automatically to 2nd, then 3rd, depending on vehicle speed and throttle position. Downshifts through 2nd to 1st on deceleration to stop. The lock-up mechanism comes into operation in 3rd speed.
2 SECOND	For engine braking or better traction starting off on loose or slippery surfaces; stays in 2nd gear, does not shift up or down.
1 FIRST	For engine braking; stays in 1st gear, does not shift up.

Starting is possible only in **P** and **N** positions through the use of a slide-type, neutral-safety switch.

Automatic Transaxle (A/T) Gear Position Indicator

A/T gear position indicator in the instrument panel shows what gear has been selected without having to look down at the console.

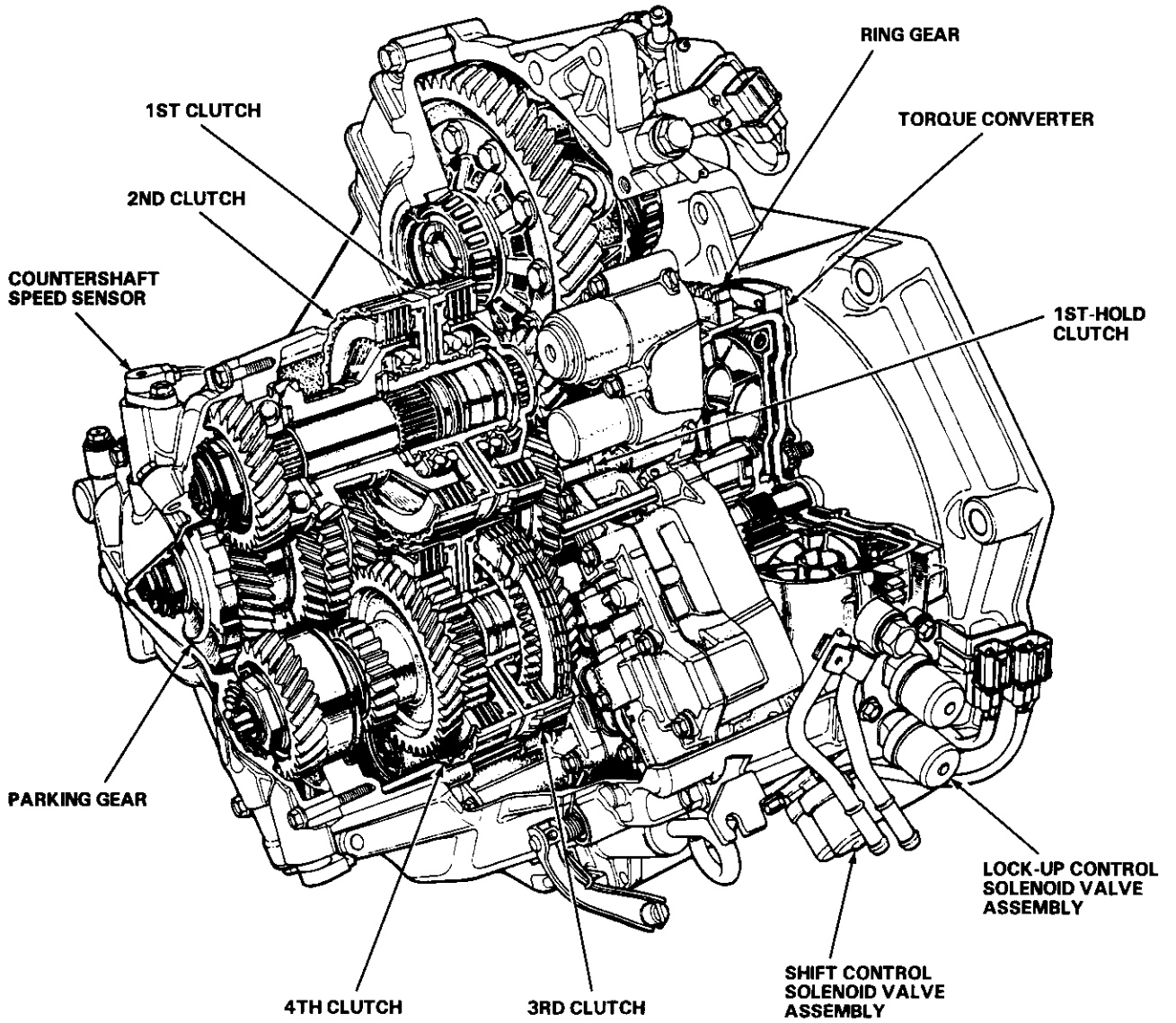

Description

Clutches

The four-speed automatic transmission uses hydraulically actuated clutches to engage or disengage the transmission gears. When clutch pressure is introduced into the clutch drum, the clutch piston is applied. This presses the friction discs and steel plates together, locking them so they don't slip. Power is then transmitted through the engaged clutch pack to its hub-mounted gear.

Likewise, when clutch pressure is bled from the clutch pack, the piston releases the friction discs and steel plates, and they are free to slide past each other while disengaged. This allows the gear to spin independently of its shaft, transmitting no power.

1st Clutch

The 1st clutch engages/disengages 1st gear, and is located at the center of the secondary shaft.

The 1st clutch is joined back-to-back to the 2nd clutch.

The 1st clutch is supplied clutch pressure by its oil feed pipe within the secondary shaft.

1st-hold Clutch

The 1st-hold clutch engages/disengages 1st-hold or position, and is located at the end of the countershaft, just behind the torque converter housing. The 1st-hold clutch is supplied clutch pressure by its oil feed pipe within the countershaft.

2nd Clutch

The 2nd clutch engages/disengages 2nd gear, and is located at the center of the secondary shaft. The 2nd clutch is joined back-to-back to the 1st clutch. The 2nd clutch is supplied clutch pressure through the secondary shaft by a circuit connected to the internal hydraulic circuit.

3rd Clutch

The 3rd clutch engages/disengages 3rd gear, and is located at the center of the mainshaft.

The 3rd clutch is joined back-to-back to the 4th clutch.

The 3rd clutch is supplied clutch pressure through the mainshaft by a circuit connected to the regulator valve body.

4th Clutch

The 4th clutch engages/disengages 4th gear, as well as reverse gear, and is located at the center of the mainshaft. The 4th clutch is joined back-to-back to the 3rd clutch. The 4th clutch is supplied clutch pressure by its oil feed pipe within the mainshaft.

One-way Clutch

The one-way clutch is positioned between the countershaft 1st gear and 3rd gear, with the 3rd gear splined to the countershaft. The 1st gear provides the outer race surface, and the 3rd gear provides the inner race surface. The one-way clutch locks up when power is transmitted from the mainshaft 1st gear to the countershaft 1st gear.

The 1st clutch and gears remain engaged in the , or position.

However, the one-way clutch disengages when the 2nd, 3rd, or 4th clutches/gears are applied in the , or position. This is because the increased rotational speed of the gears on the countershaft overrides the locking "speed range" of the one-way clutch. Thereafter, the one-way clutch freewheels with the 1st clutch still engaged.

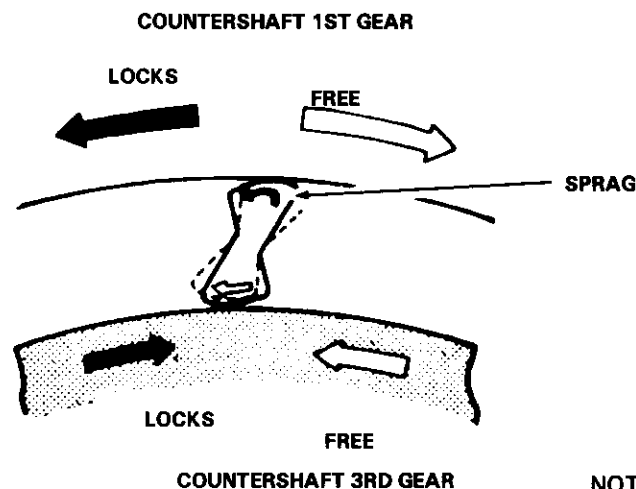

NOTE:

View from right side cover side.

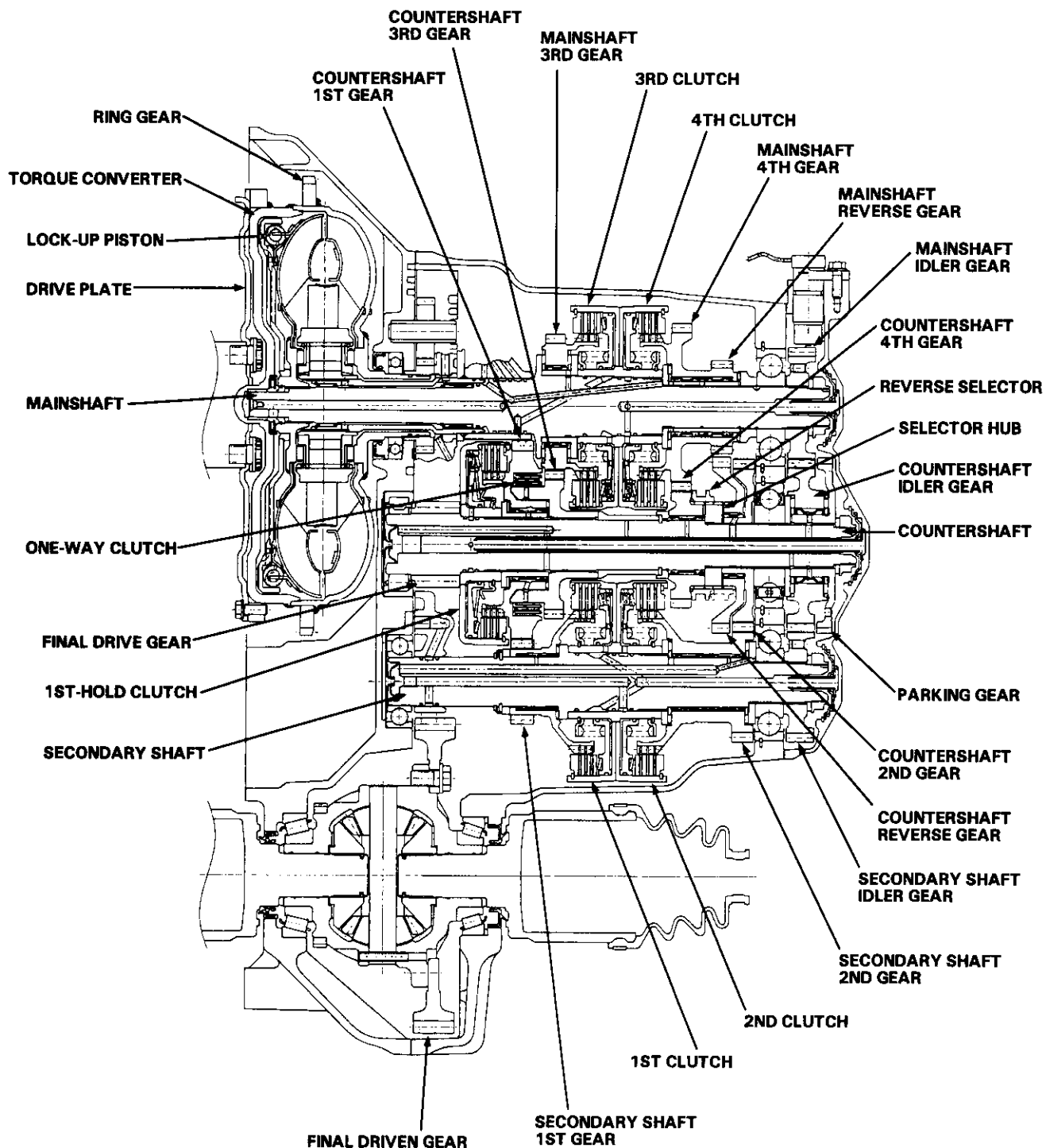

(cont'd)

Description

Clutches (cont'd)

Lock-up Clutch

1. Operation (clutch on)

With the lock-up clutch on, the oil in the chamber between the converter cover and lock-up piston is drained off, and the converter oil exerts pressure through the piston against the converter cover. As a result, the converter turbine is locked to the converter cover. The effect is to bypass the converter, thereby placing the car in direct drive.

Power flow

The power flows by way of:

Engine
 ↓
 Drive plate
 ↓
 Torque converter cover
 ↓
 Lock-up piston
 ↓
 Damper spring
 ↓
 Turbine
 ↓
 Mainshaft

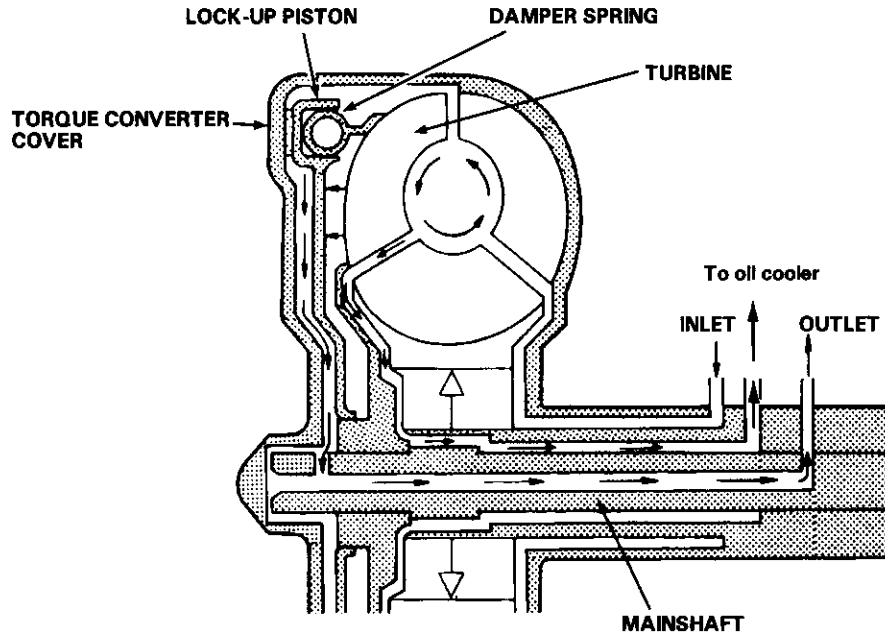

2. Operation (clutch off)

With the lock-up clutch off, the oil flows in the reverse of CLUTCH ON. As a result, the lock-up piston moves away from the converter cover and the torque converter lock-up is released.

Power flow

Engine
 ↓
 Drive plate
 ↓
 Torque converter cover
 ↓
 Pump
 ↓
 Turbine
 ↓
 Mainshaft

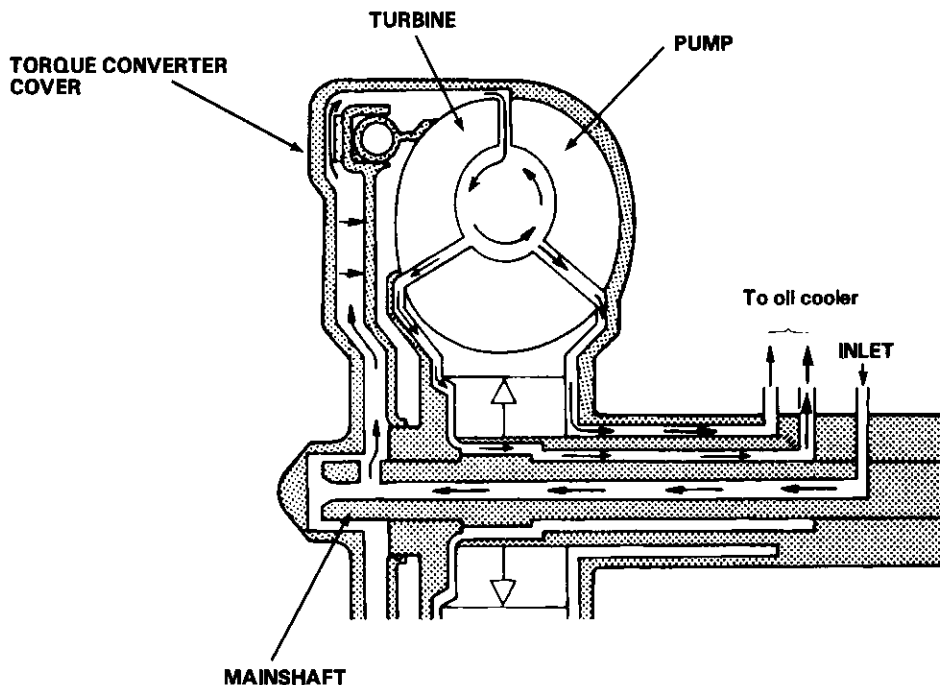



Power Flow

PART POSITION	TORQUE CON-VERTER	1ST GEAR 1ST-HOLD CLUTCH	1ST GEAR 1ST CLUTCH	1ST GEAR ONE-WAY CLUTCH	2ND GEAR 2ND CLUTCH	3RD GEAR 3RD CLUTCH	4TH		REVERSE GEAR	PARKING GEAR
							GEAR	CLUTCH		
P	○	×	×	×	×	×	×	×	×	○
R	○	×	×	×	×	×	×	○	○	×
N	○	×	×	×	×	×	×	×	×	×
D4	1ST	○	×	○	×	×	×	×	×	×
	2ND	○	×	*○	○	×	×	×	×	×
	3RD	○	×	*○	×	○	×	×	×	×
	4TH	○	×	*○	×	×	○	○	×	×
D3	1ST	○	×	○	×	×	×	×	×	×
	2ND	○	×	*○	○	×	×	×	×	×
	3RD	○	×	*○	×	○	×	×	×	×
2	○	×	*○	×	○	×	×	×	×	
1	○	○	○	○	×	×	×	×	×	×

○: Operates, ×: Doesn't operate, *: Although the 1st clutch engages, driving power is not transmitted as the one-way clutch slips.

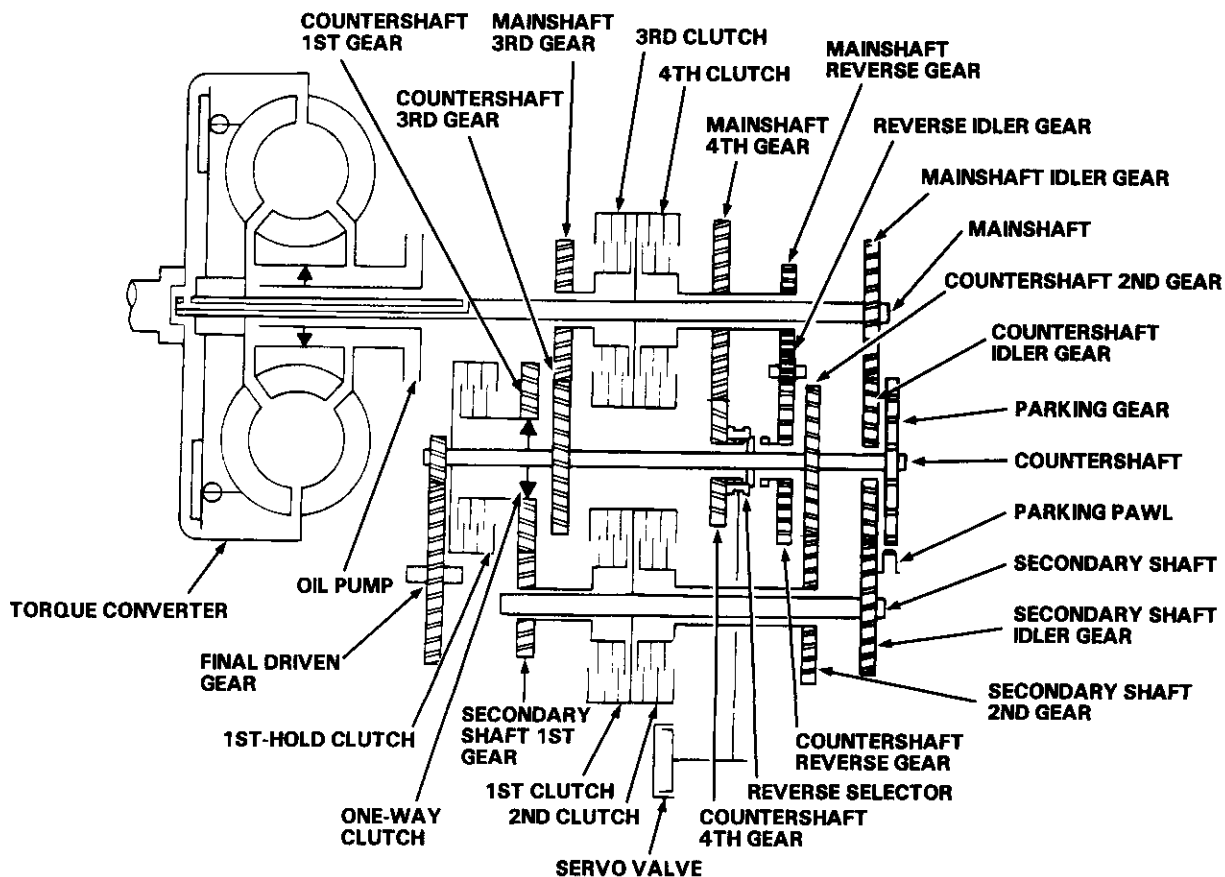

Description

Electronic Control System

Electronic Control System

The electronic control system consists of the Transmission Control Module (TCM), sensors, and 4 solenoid valves. Shifting and lock-up are electronically controlled for comfortable driving under all conditions.

The TCM is located below the dashboard, behind the right side kick panel on the passenger's side.

Shift Control

Getting a signal from each sensor, the TCM determines the appropriate gear and activates shift control solenoid valves A and/or B.

The combination of driving signals to shift control solenoid valves A and B is shown in the table below.

Shift control solenoid valve Position (gear)	A	B
1 (1st)	ON	OFF
2 (2nd)	ON	ON
D4 D3 (1st)	OFF	ON
D4 D3 (2nd)	ON	ON
D4 D3 (3rd)	ON	OFF
D4 (4th)	OFF	OFF
R	ON	OFF

Lock-up Control

From sensor input signals, the TCM determines whether to turn the lock-up ON or OFF and activates lock-up control solenoid valve A and/or B accordingly.

The combination of driving signals to lock-up control solenoid valves A and B is shown in the table below.

Solenoid valve Lock-up condition	A	B
Lock-up OFF	OFF	OFF
Lock-up, slight	ON	Duty operation OFF ↔ ON
Lock-up, half	ON	ON
Lock-up, full	ON	ON
Lock-up during deceleration	ON	Duty operation OFF ↔ ON



TCM

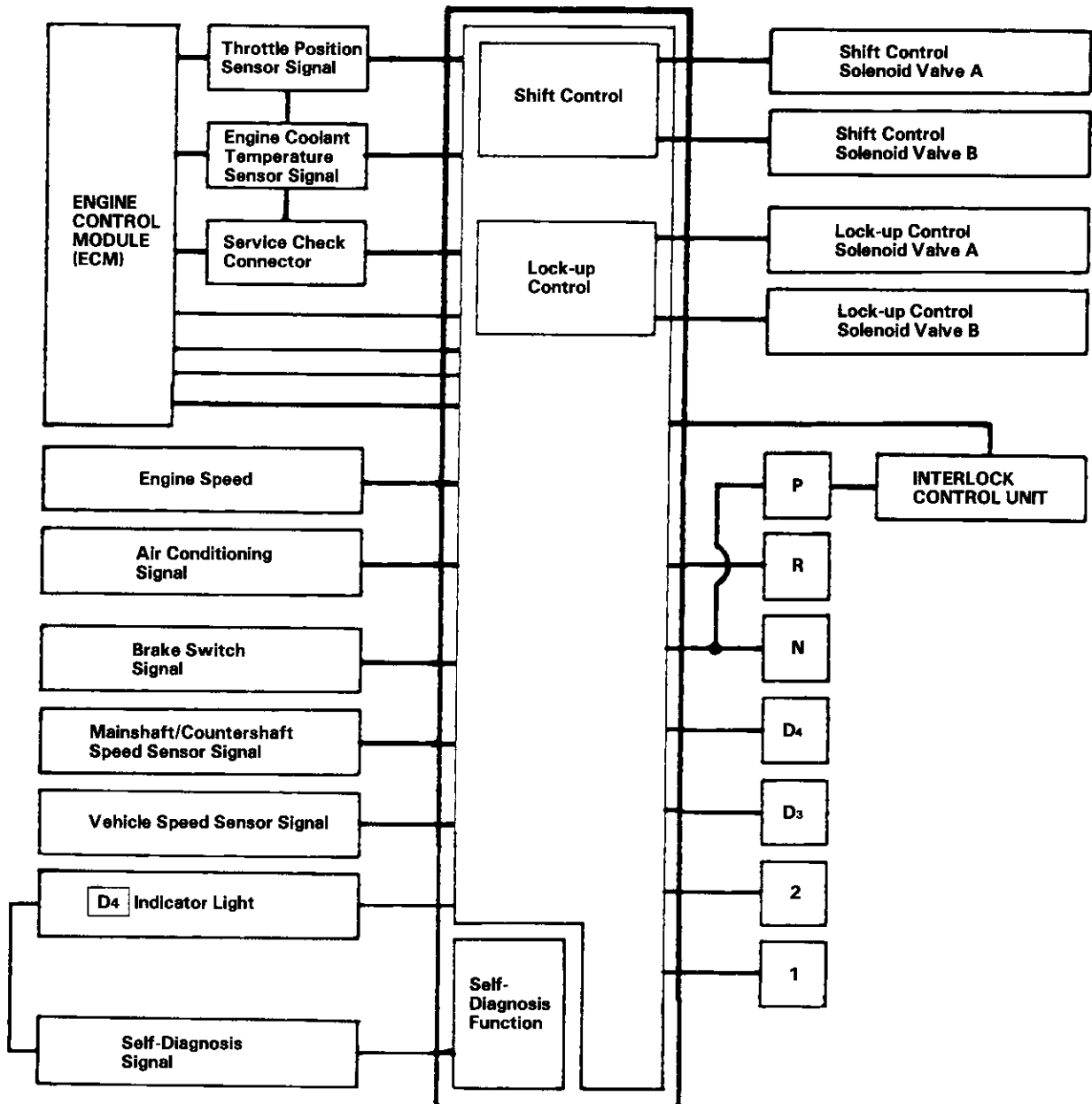

(cont'd)

Description

Electronic Control System (cont'd)

Circuit Diagram and Terminal Location

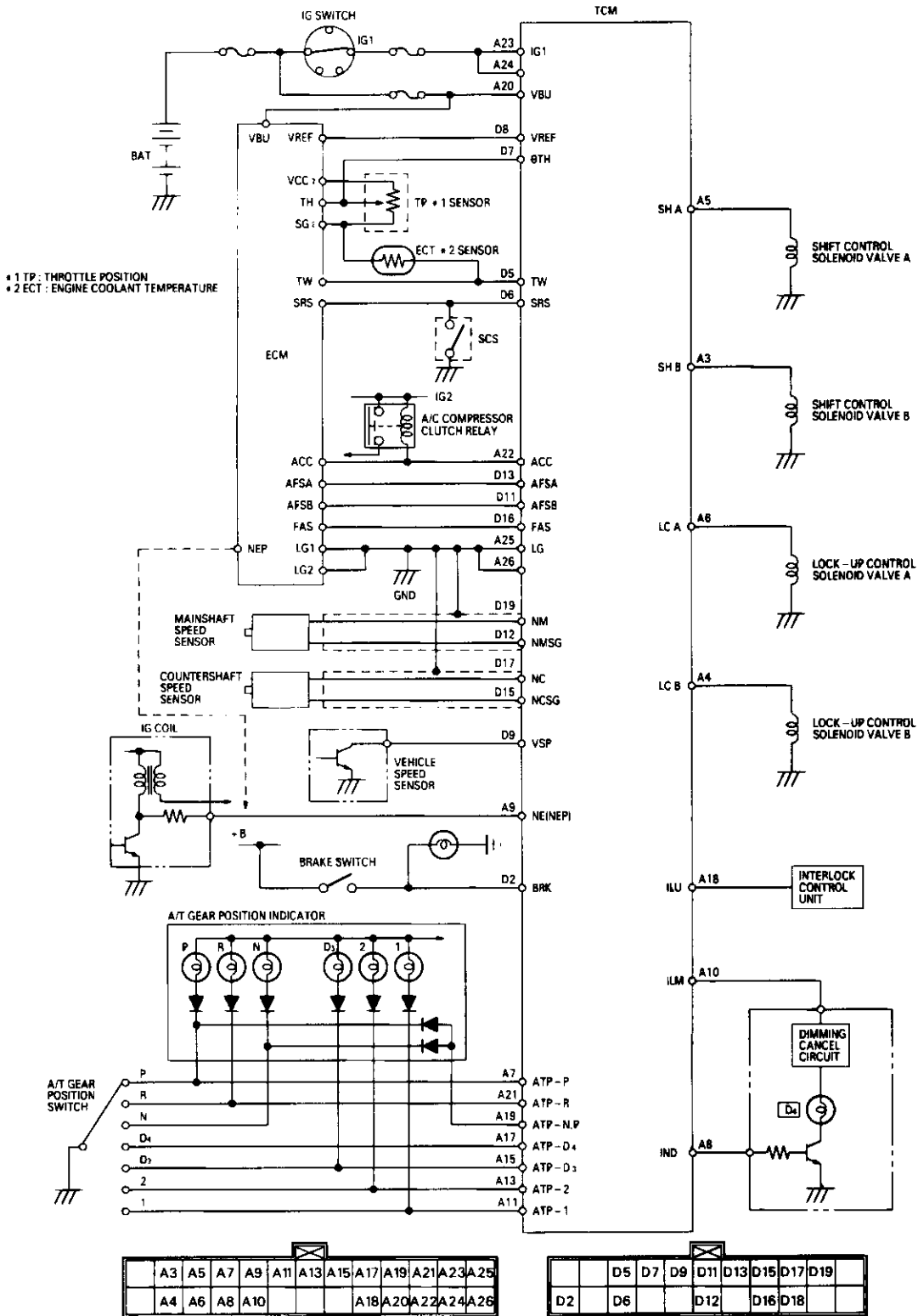



Hydraulic Flow

No.	DESCRIPTION OF PRESSURE	No.	DESCRIPTION OF PRESSURE	No.	DESCRIPTION OF PRESSURE	No.	DESCRIPTION OF PRESSURE
1	LINE	6'	MODULATE (DUTY CONTROL)	30	3RD CLUTCH	93	OIL COOLER
2	LINE	9	LINE	31	3RD CLUTCH	94	TORQUE CONVERTER
3	LINE	10	1ST CLUTCH	40	4TH CLUTCH	95	LUBRICATION
3'	LINE	15	1ST-HOLD CLUTCH	41	4TH CLUTCH	96	TORQUE CONVERTER
3''	LINE	16	1ST-HOLD CLUTCH	55	THROTTLE B	99	SUCTION
4	LINE	18	LINE	56	THROTTLE B	X	BLEED
4'	LINE	20	2ND CLUTCH	90	TORQUE CONVERTER		
5	LINE	21	2ND CLUTCH	91	TORQUE CONVERTER		
6	MODULATE	25	LINE	92	TORQUE CONVERTER		

N Position

As the engine turns, the oil pump also starts to operate. Automatic transmission fluid (ATF) is drawn from (99) and discharged into (1). Then, ATF pressure is controlled by the regulator valve and becomes the line pressure (1). The torque converter inlet pressure (92) enters (94) of torque converter through the orifice and discharges into (90).

The torque converter check valve prevents the torque converter pressure from rising.

Under this condition, the hydraulic pressure is not applied to the clutches as the manual valve stops line pressure (1).

NOTE:

When used, "left" or "right" indicates direction on the flowchart.

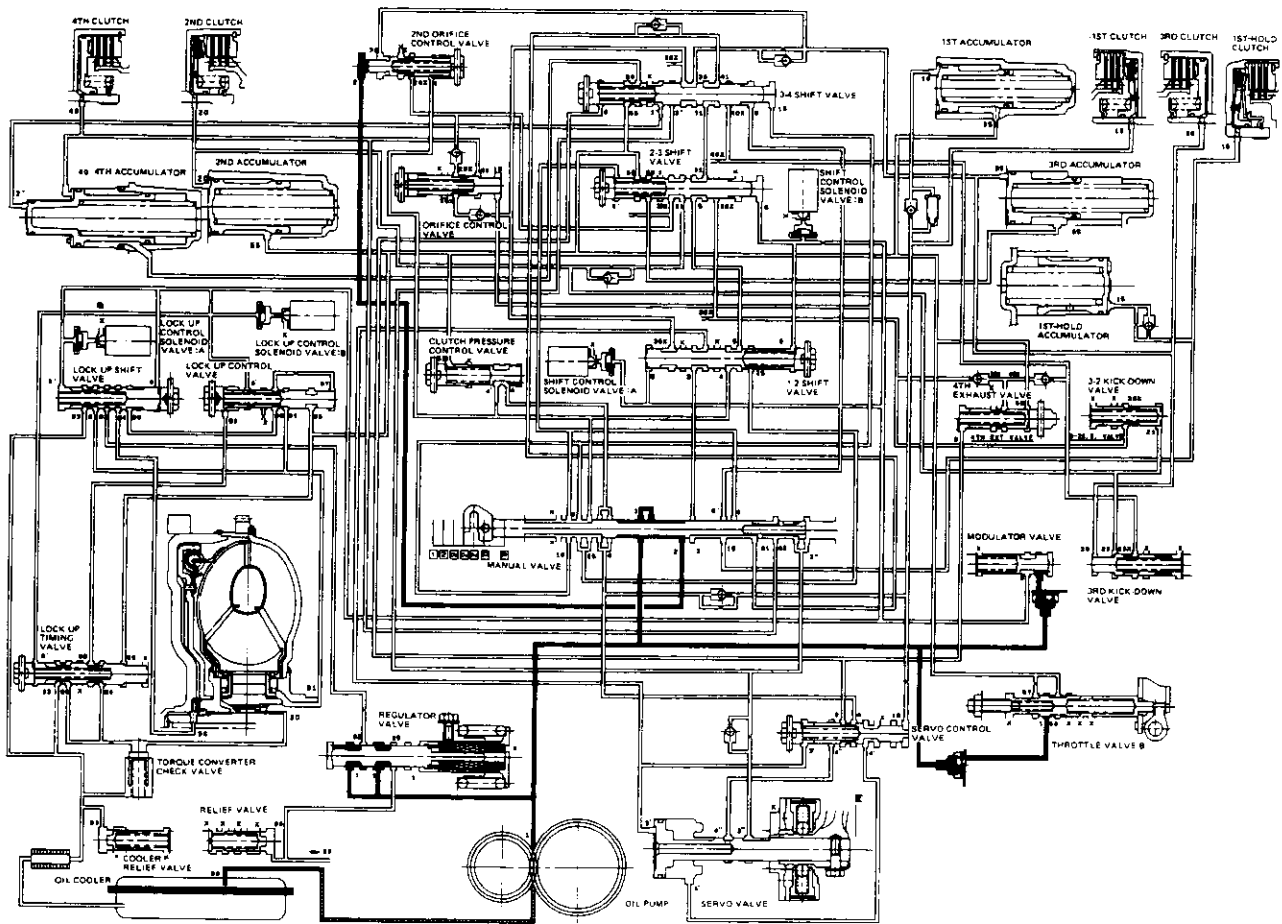

(cont'd)

Description

Hydraulic Flow (cont'd)

1 Position

The line pressure (1) becomes line pressure (4) at the manual valve and passes to the 1st clutch and 1st accumulator. Then line pressure (4) flows through the 1st-hold clutch and 1st-hold accumulator. The power is transmitted only during deceleration through the 1st-hold clutch.

Fluid flows by way of:

— Line Pressure (4) → 1-2 Shift Valve → 2-3 Shift Valve — 3rd Clutch Pressure (31) → 3-4 Shift Valve — 4th Clutch Pressure (41) → Manual Valve — 1st-hold Clutch Pressure (16) → 1st-hold Clutch

The modulator pressure (6) is supplied to the 1-2 and 2-3 shift valves.

The line pressure (1) also flows to throttle valve B.

NOTE:

When used, "left" or "right" indicates direction on the flowchart.

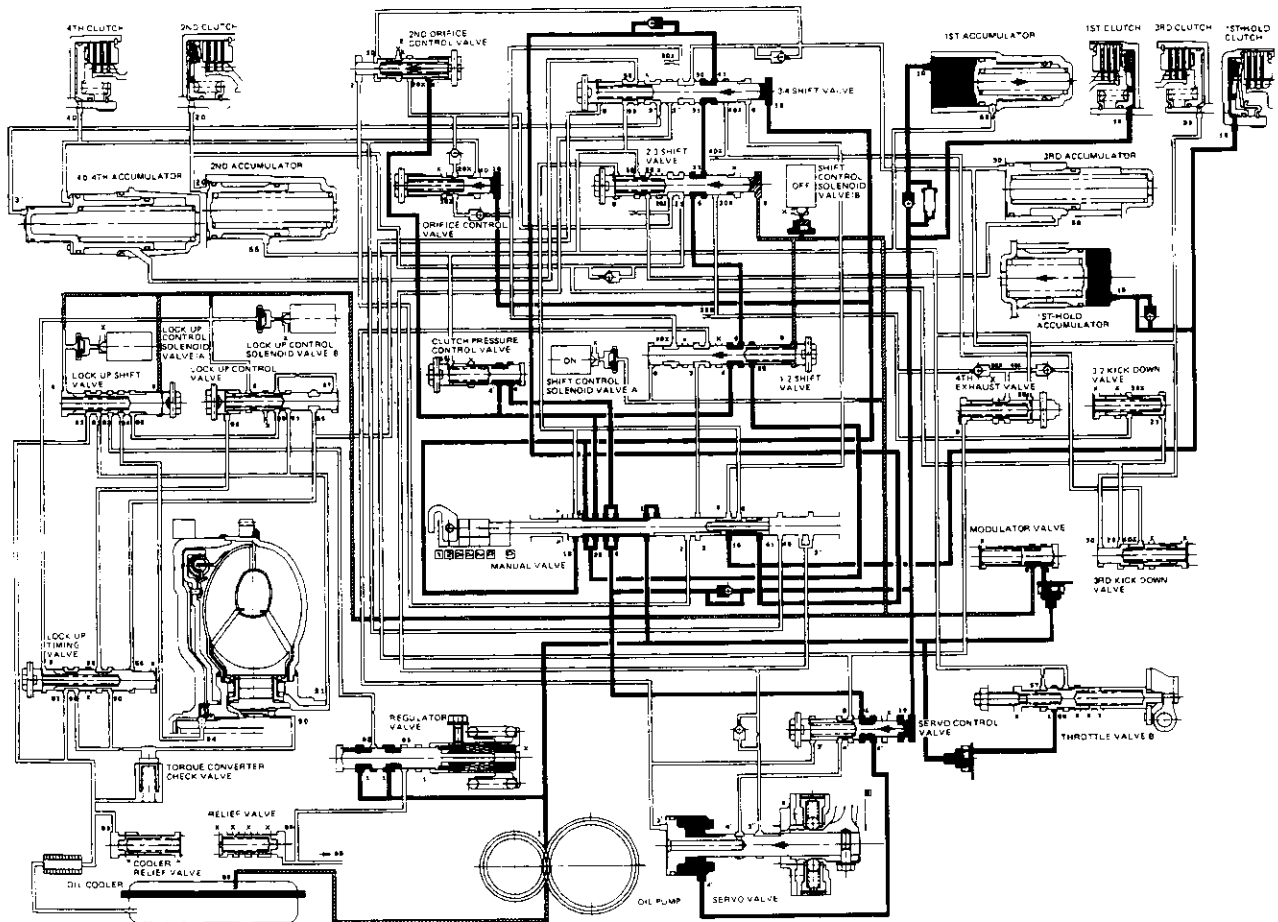



2 Position

The line pressure (1) becomes line pressure (4) as it passes through the manual valve. It then goes through line (20) to the 2nd clutch. Also, line pressure (1) goes to the modulator valve through the filter and becomes the modulator pressure (6). Modulator pressure (6) is not supplied to the 1-2, 2-3 and 3-4 shift valves. Line pressure (1) also flows to throttle valve B.

NOTE:

When used, "left" or "right" indicates direction on the flowchart.

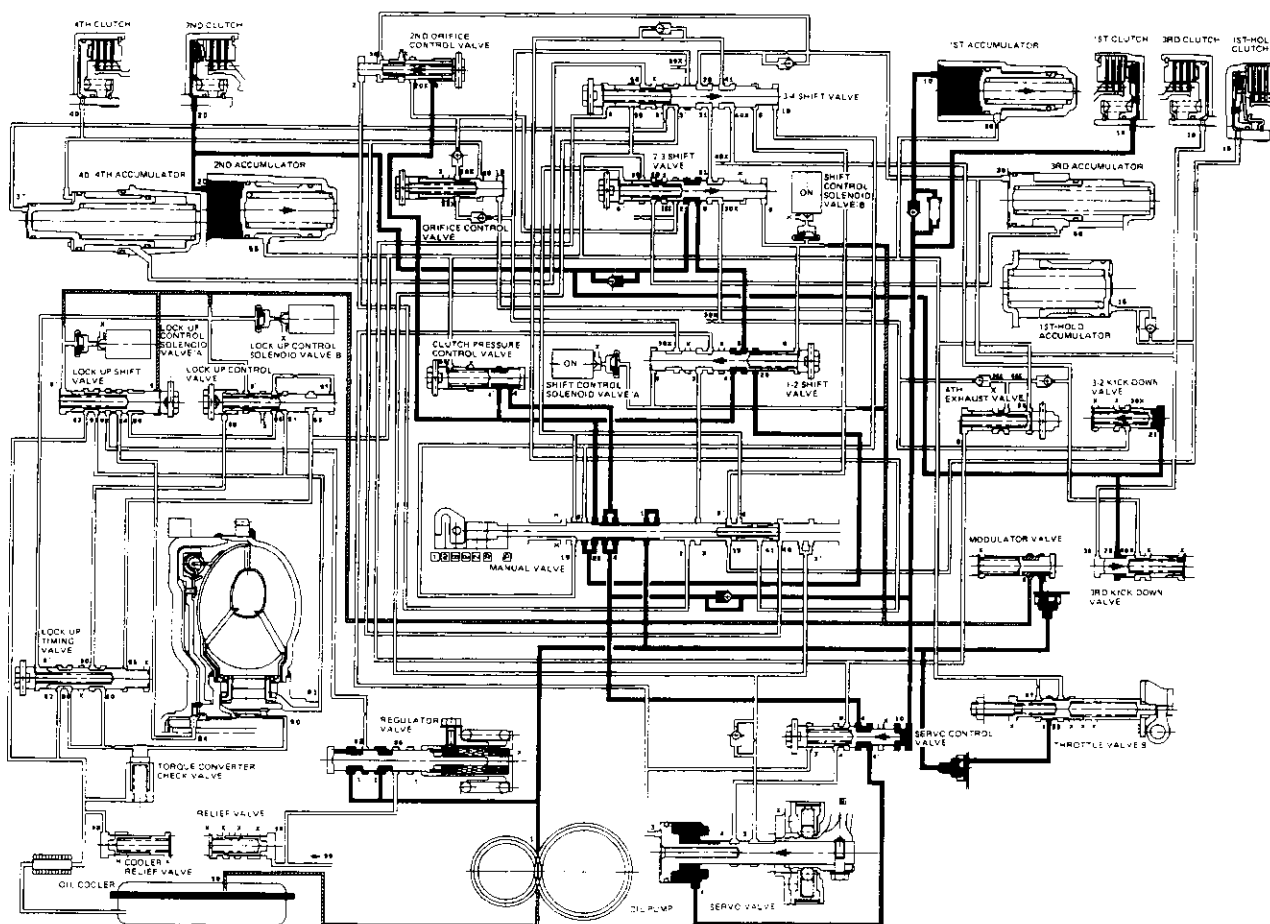

(cont'd)

Description

Hydraulic Flow (cont'd)

D3 or **D4** Position

1. 1st Speed

The flow of fluid through the torque converter circuit is the same as in **N** position.

The line pressure (1) becomes line pressure (4) and it becomes the 1st clutch pressure (10). The 1st clutch pressure is applied to the 1st clutch and 1st accumulator; consequently, the vehicle will move as the engine power is transmitted.

The line pressure (1) becomes the modulator pressure (6) by the modulator valve and travels to 1-2 and 3-4 shift valves. The 1-2 shift valve is moved to the right side because the shift control solenoid valve A is turned off and B is turned on by the TCM. This valve stops 2nd clutch pressure and the power is not transmitted to the 2nd clutch.

Line pressure (4) also flows to the servo valve and line pressure (1) also flows to throttle valve B.

NOTE:

When used, "left" or "right" indicates direction on the flowchart.

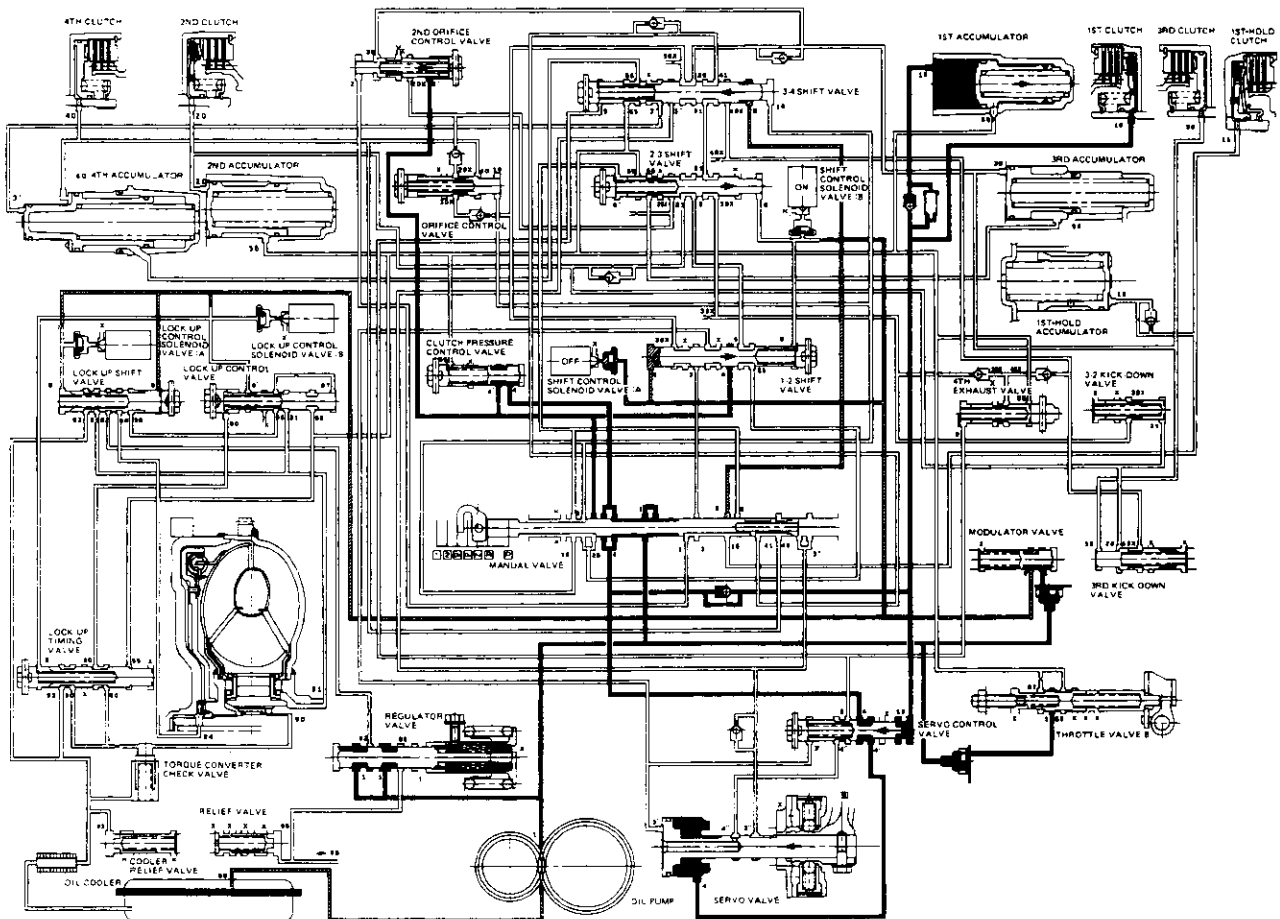



2. 2nd Speed

The flow of fluid up the 1-2 and 2-3 shift valves is the same as in the 1st speed. As the speed of the car reaches the prescribed value, the solenoid valve A is turned on by means of the TCM. As a result, the 1-2 shift valve is moved to the left and uncovers the port leading to the 2nd clutch; the 2nd clutch is engaged.

Fluid flows by way of:

— Line pressure (4) → 1-2 Shift Valve → 2-3 Shift Valve — 2nd Clutch Pressure (21) → Orifice — 2nd Clutch Pressure (20) → 2nd Clutch

The hydraulic pressure also flows to the 1st clutch. However, no power is transmitted because of the one-way clutch.

NOTE:

When used, "left" or "right" indicates direction on the flowchart.

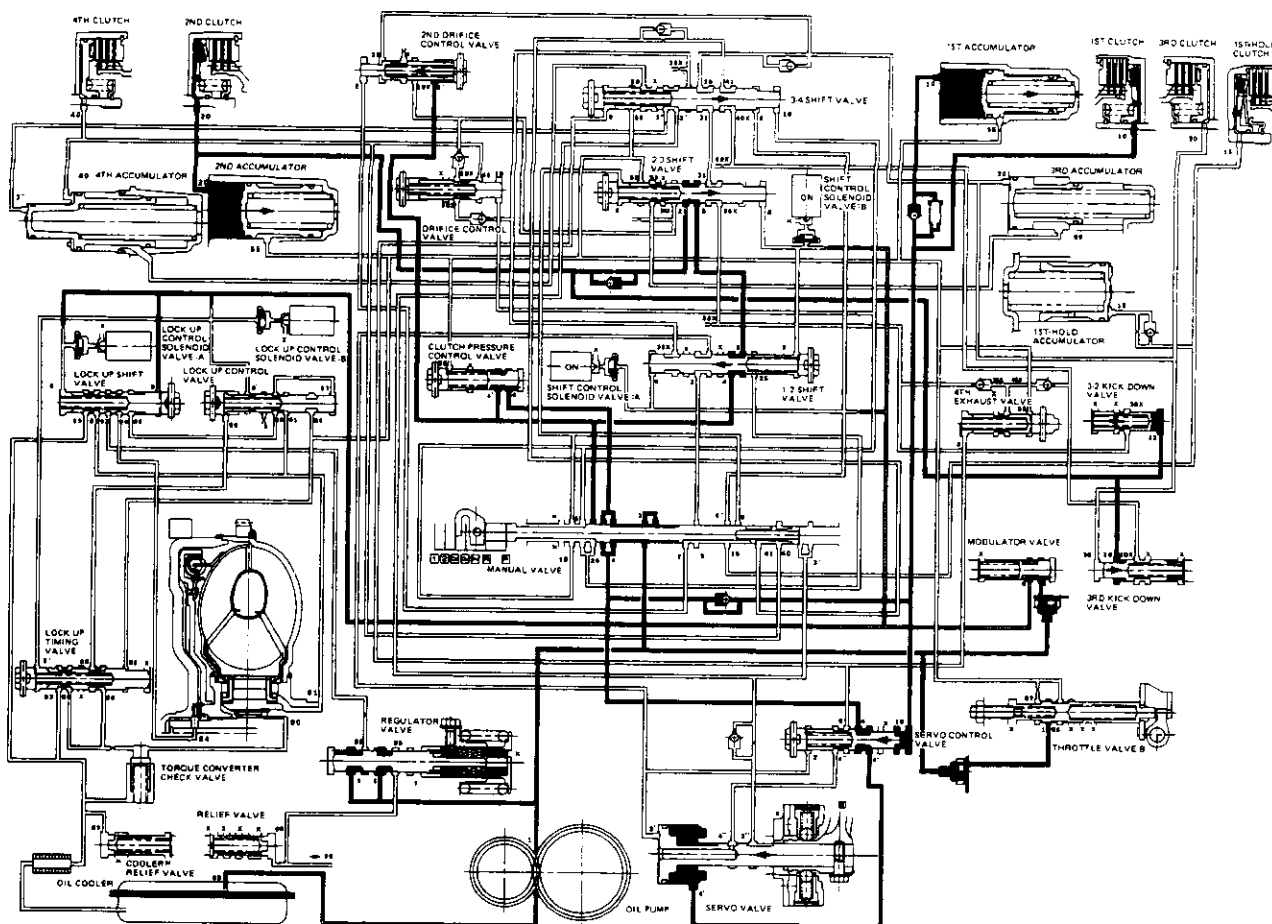

(cont'd)



D4 Position

4th Speed

The flow of fluid up to the 1-2, 2-3 and 3-4 shift valves is the same as in the 3rd speed. As the speed of the car reaches the prescribed value, the shift control solenoid valve A is turned off (shift control solenoid valve B remains off).

As this takes place, 3-4 shift valve is moved to the left and uncovers the oil port leading to the 4th clutch. Since the 1-2 and 2-3 shift valves are kept on the left side, the fluid flows through the 4th clutch; the power is transmitted through the 4th clutch.

Fluid flows by way of:

- Line Pressure (4) → 1-2 Shift Valve → 2-3 Shift Valve — 3rd Clutch Pressure (31) → 3-4 Shift Valve — 4th Clutch pressure (41) → Manual Valve — 4th Clutch Pressure (40) → 4th Clutch

The hydraulic pressure also flows to the 1st clutch. However, no power is transmitted because of the one-way clutch as in 2nd and 3rd speed.

NOTE:

When used, "left" or "right" indicates direction on the flowchart.

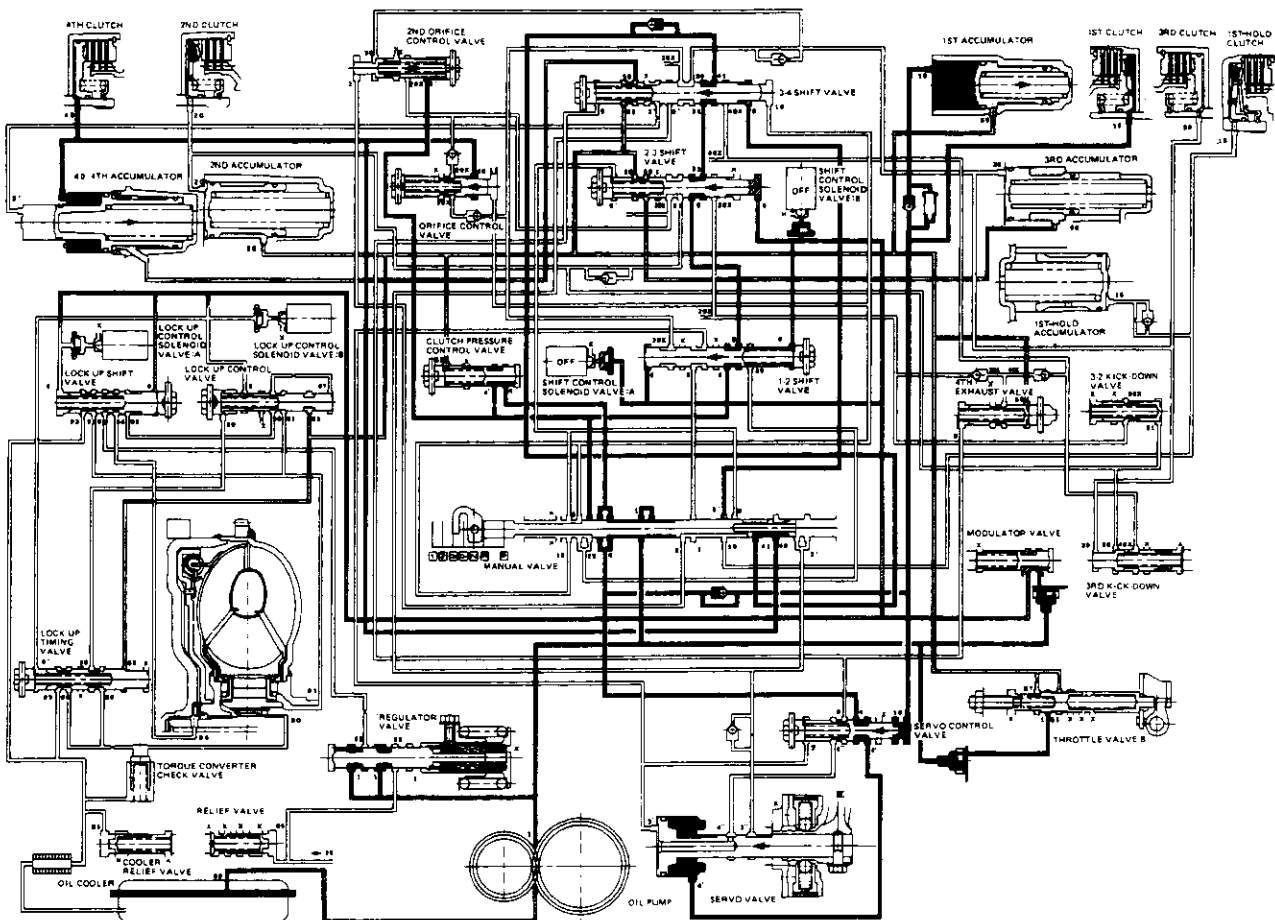

(cont'd)

Description

Hydraulic Flow (cont'd)

R Position

The flow of fluid through the torque converter circuit is the same as in the **N** position. The fluid (1) from the oil pump flows through the manual valve and becomes line pressure (3). It then flows through the 1-2 shift valve to the servo valve (3), causing the shift fork shaft to be moved in the reverse direction.

Under this condition, the shift control solenoid valve A is turned on whereas the valve B is turned off as in 3rd speed in **D4** or **D3** position. As a result, the 1-2 shift valve is also moved to the left. The fluid (3') will flow through the servo valve and manual valve to the 4th clutch; power is transmitted through the 4th clutch.

Reverse Inhibitor Control

When the **R** position is selected while the vehicle is moving forward at a speed over 6 mph (10 km/h), the TCM outputs 1st signal (A: OFF, B: ON), and the 1-2 shift valve is moved to the right side. The line pressure (3) is intercepted by the 1-2 shift valve; consequently, power is not transmitted as the 4th clutch and servo valve are not operated.

NOTE:

When used, "left" or "right" indicates direction on the flowchart.

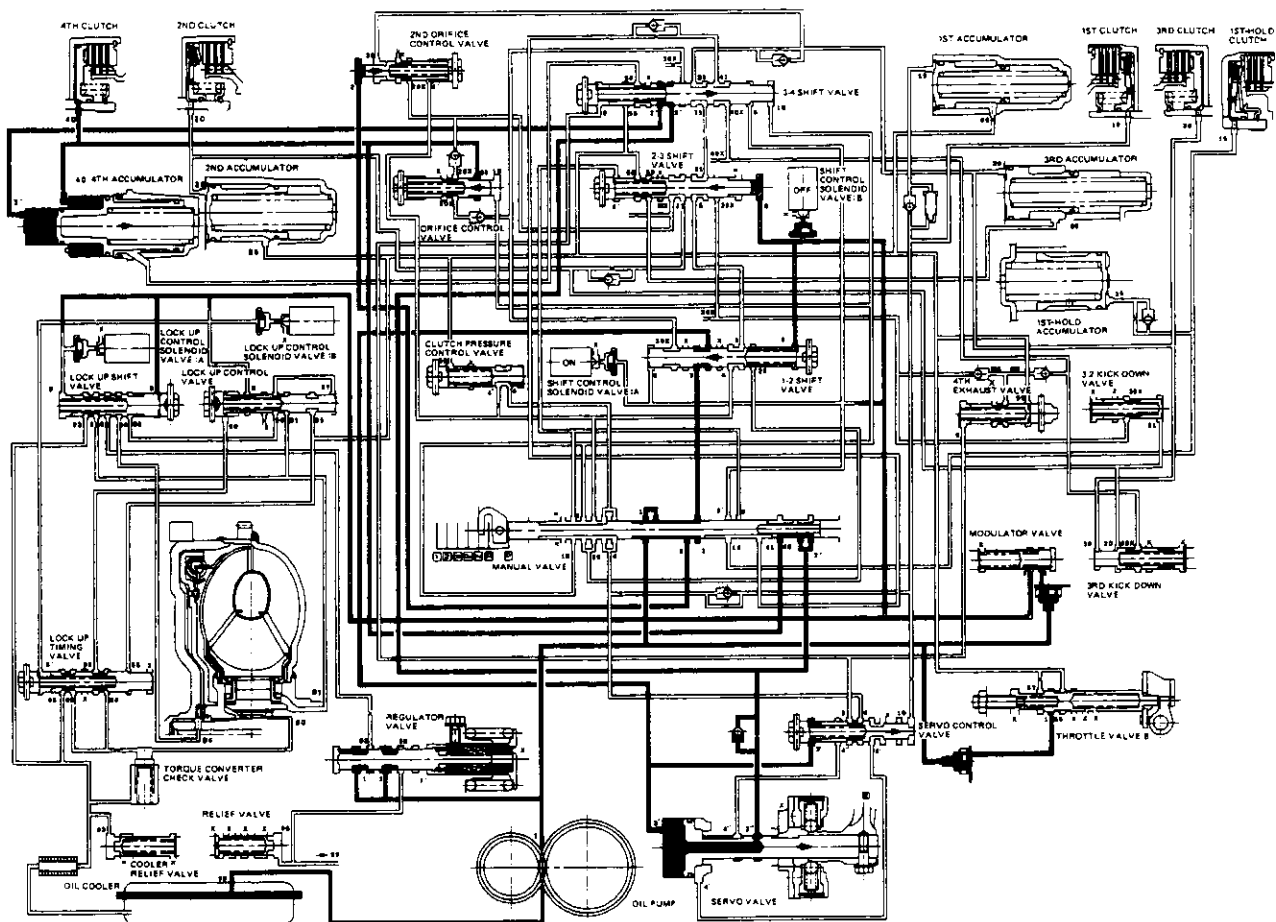



P Position

The flow of fluid through the torque converter circuit is the same as in **N** position. The line pressure (1) becomes the line pressure (3) as it passes through the manual valve. Then line pressure (3) flows through the 1-2 shift valve to the servo valve and the servo control valve, causing the shift fork shaft to be moved to the reverse position as in the **R** position. However, the hydraulic pressure is not supplied to the clutches. The power is not transmitted.

NOTE:

When used, "left" or "right" indicates direction on the flowchart.

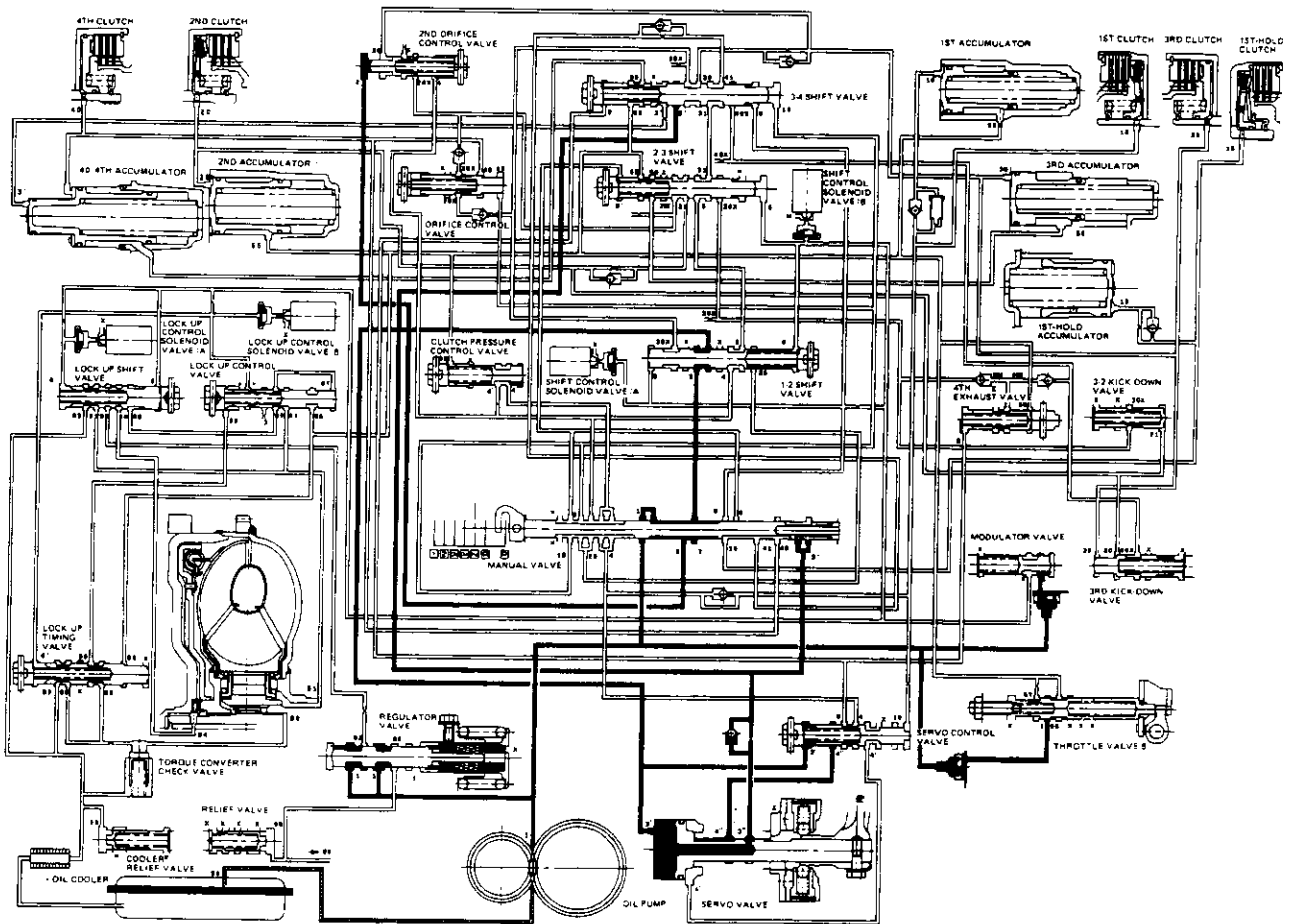

Description

Lock-up System

In **D4** position in 2nd, 3rd and 4th, and **D3** position in 3rd, pressurized fluid is drained from the back of the torque converter through an oil passage, causing the lock-up piston to be held against the torque converter cover. As this takes place, the mainshaft rotates at the same speed as the engine crankshaft. Together with hydraulic control, the TCM optimizes the timing of the lock-up system. Under certain conditions, the lock-up clutch is applied during deceleration, in 3rd and 4th speed.

The lock-up system controls the range of lock-up according to lock-up control solenoid valves A and B, and throttle valve B. When lock-up control solenoid valves A and B activate, modulator pressure changes. Lock-up control solenoid valves A and B are mounted on the torque converter housing, and are controlled by the TCM.

NOTE:

When used, "left" or "right" indicates direction on the flowchart.

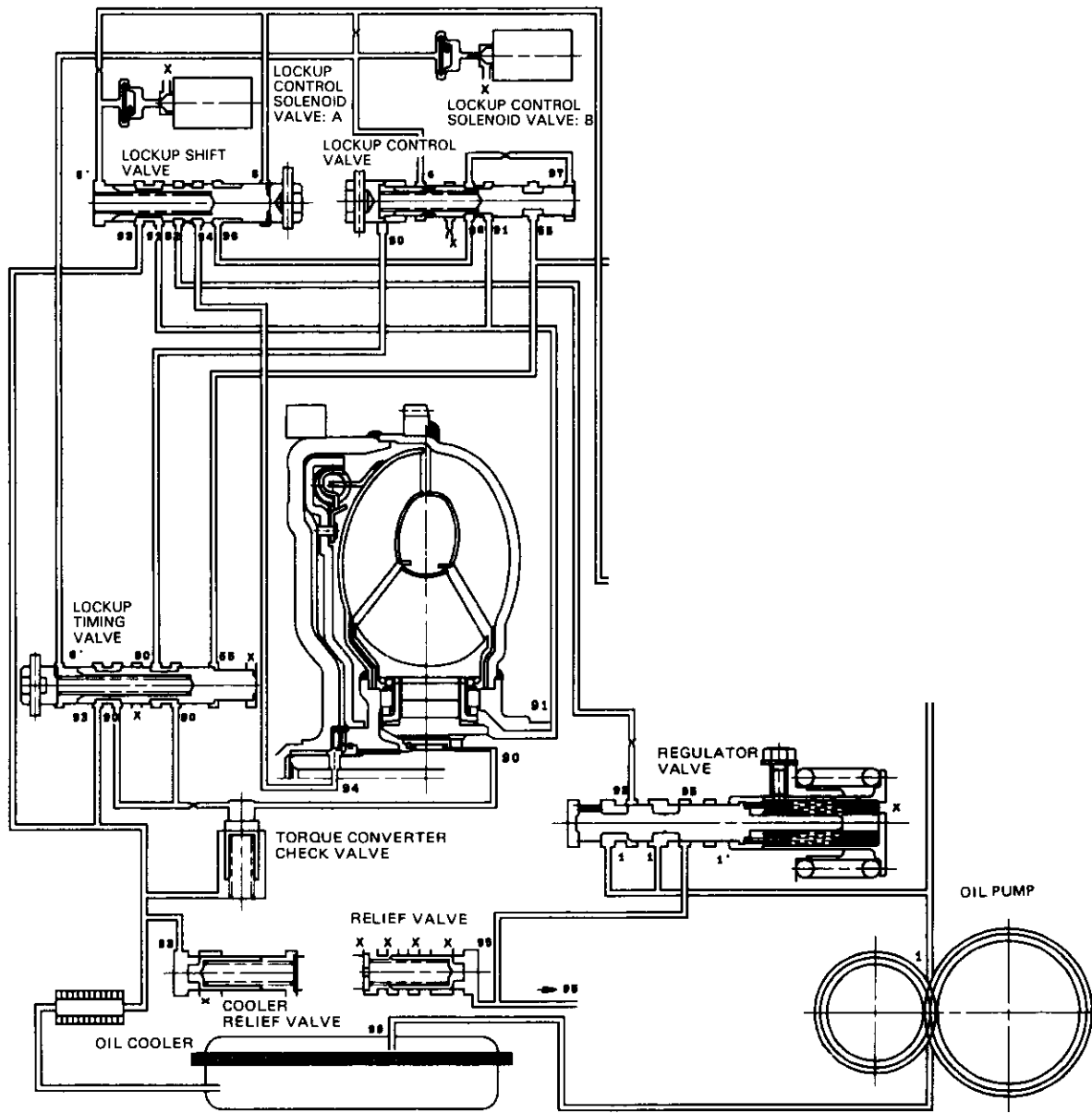



No Lock-up

The pressurized fluid regulated by the modulator works on both ends of the lock-up shift valve and on the left side of the lock-up control valve. Under this condition, the pressures working on both ends of the lock-up shift valve are equal, the shift valve is moved to the right side by the tension of the valve spring alone. The fluid from the oil pump will flow through the left side of the lock-up clutch to the torque converter; i.e., the lock-up clutch is in OFF condition.

NOTE:

When used, "left" or "right" indicates direction on the flowchart.

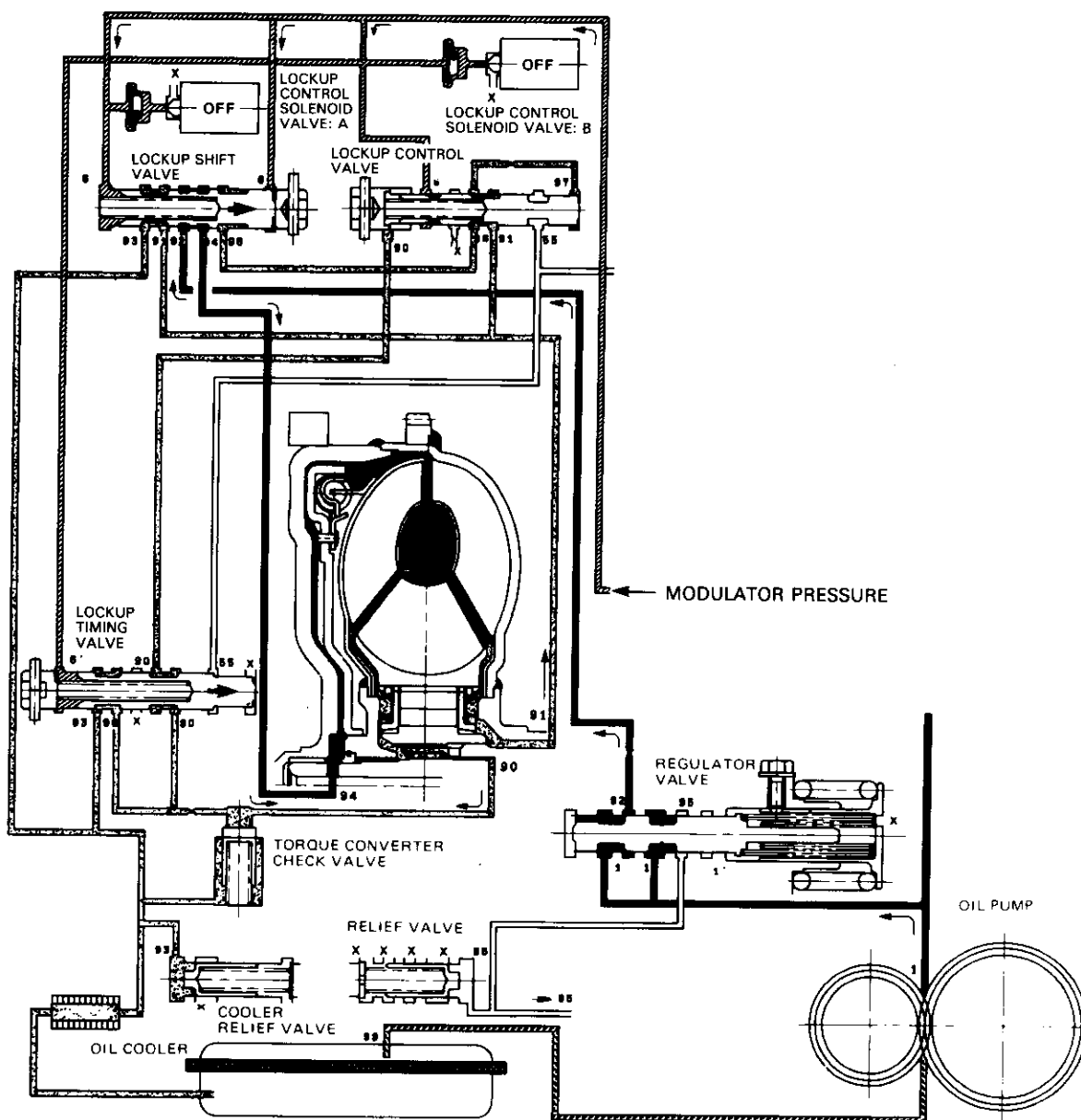

(cont'd)

Description

Lock-up System (cont'd)

Partial Lock-up

Lock-up Control Solenoid Valve A: ON Lock-up Control Solenoid Valve B: OFF

The TCM switches the solenoid valve A on to release the modulator pressure in the left cavity of the lock-up shift valve. The modulator pressure in the right cavity of the lock-up shift valve overcomes the spring force, thus the lock-up shift valve is moved to the left side.

The modulator pressure is separated to the two passages:

Torque Converter Inner Pressure: enters into right side-to engage lock-up clutch

Torque Converter Back Pressure: enters into left side-to disengage lock-up clutch

The back pressure (F₂) is regulated by the lock-up control valve whereas the position of the lock-up timing valve is determined by the throttle B pressure, tension of the valve spring and pressure regulated by the modulator. Also the position of the lock-up control valve is determined by the back pressure of the lock-up control valve and torque converter pressure regulated by the check valve. With the lock-up control solenoid valve B kept off, the modulator pressure is maintained in the left end of the lock-up control valve; in other words, the lock-up control valve is moved slightly to the left side. This slight movement of the lock-up control valve causes the back pressure to be lowered slightly, resulting in partial lock-up.

NOTE:

When used, "left" or "right" indicates direction on the flowchart.

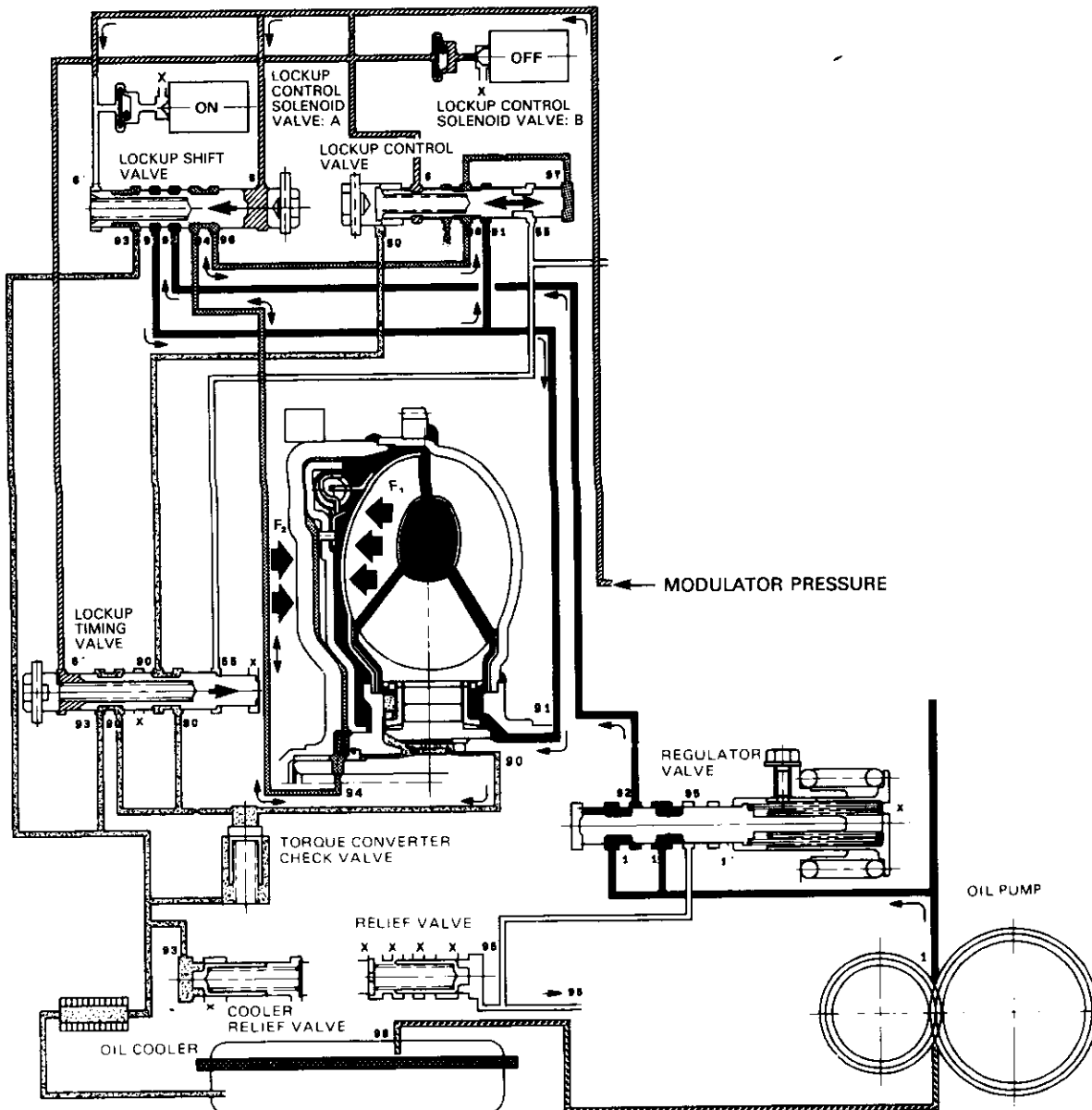



Half Lock-up

Lock-up Control Solenoid Valve A: ON Lock-up Control Solenoid Valve B: ON

The modulator pressure is released by the solenoid valve B, causing the modulator pressure in the left cavity of the lock-up control valve to lower.

Also the modulator pressure in the left cavity of the lock-up timing valve is low. However the throttle B pressure is still low at this time; consequently, the lock-up timing valve is kept on the right side by the spring force.

With the lock-up control solenoid valve B turned on, the lock-up control valve is moved somewhat to the left side, causing the back pressure (F2) to lower. This allows a greater amount of the fluid (F1) to work on the lock-up clutch so as to engage the clutch. The back pressure (F2) which still exists prevents the clutch from engaging fully.

NOTE:

When used, "left" or "right" indicates direction on the flowchart.

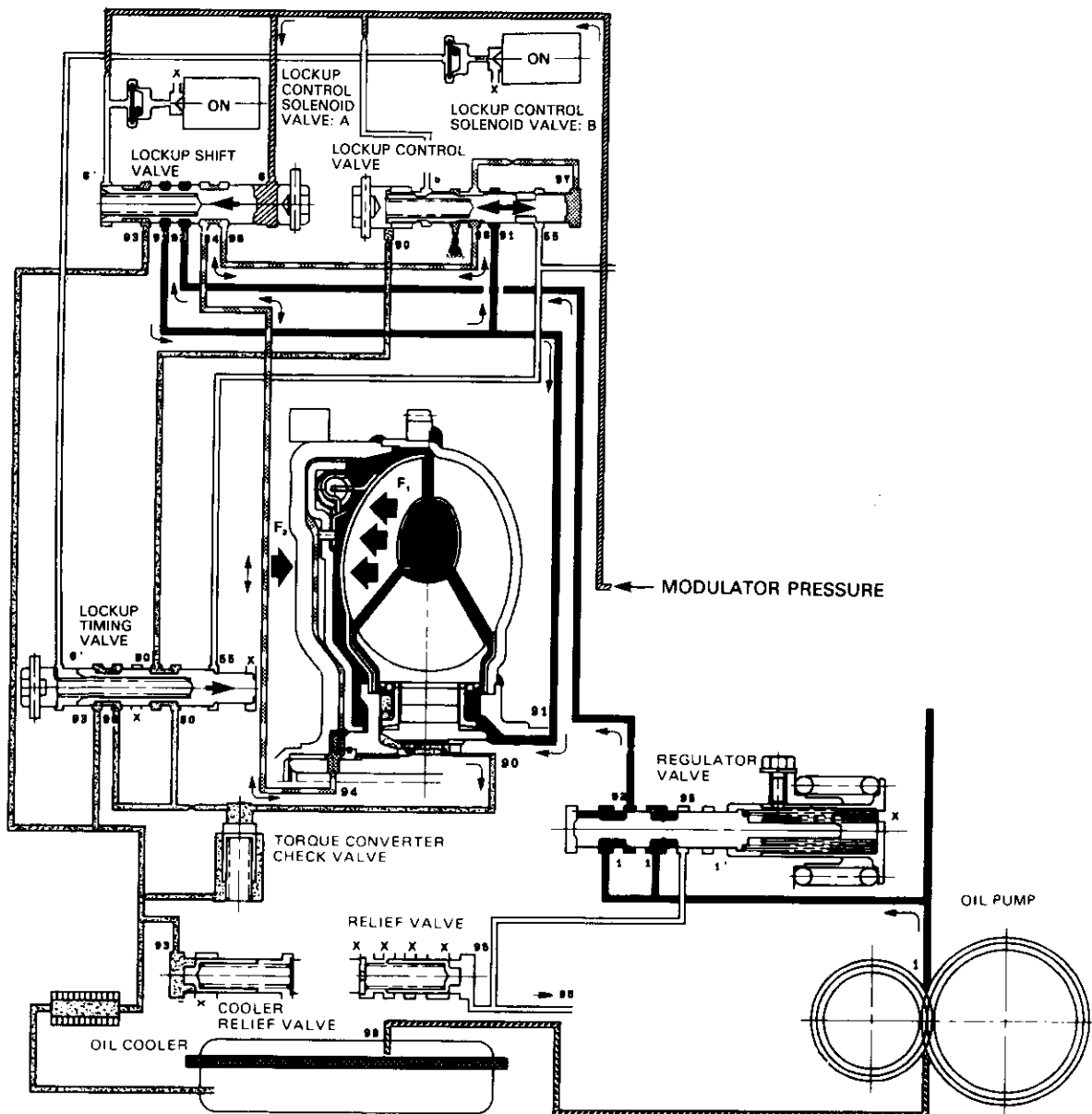

(cont'd)

Description

Lock-up System (cont'd)

Full Lock-up

Lock-up Control Solenoid Valve A: ON Lock-up Control Solenoid Valve B: ON

When the vehicle speed further increases, the throttle B pressure is increased in accordance with the throttle opening.

The lock-up timing valve overcomes the spring force and moves to the left side. Also, this valve closes the oil port leading to the torque converter check valve.

Under this condition, the throttle B pressure working on the right end of the lock-up control valve becomes greater than that on the left end (modulator pressure in the left end has already been released by the solenoid valve B); i.e., the lock-up control valve is moved to the left. As this happens, the torque converter back pressure is released fully, causing the lock-up clutch to be engaged fully.

NOTE:

When used, "left" or "right" indicates direction on the flowchart.

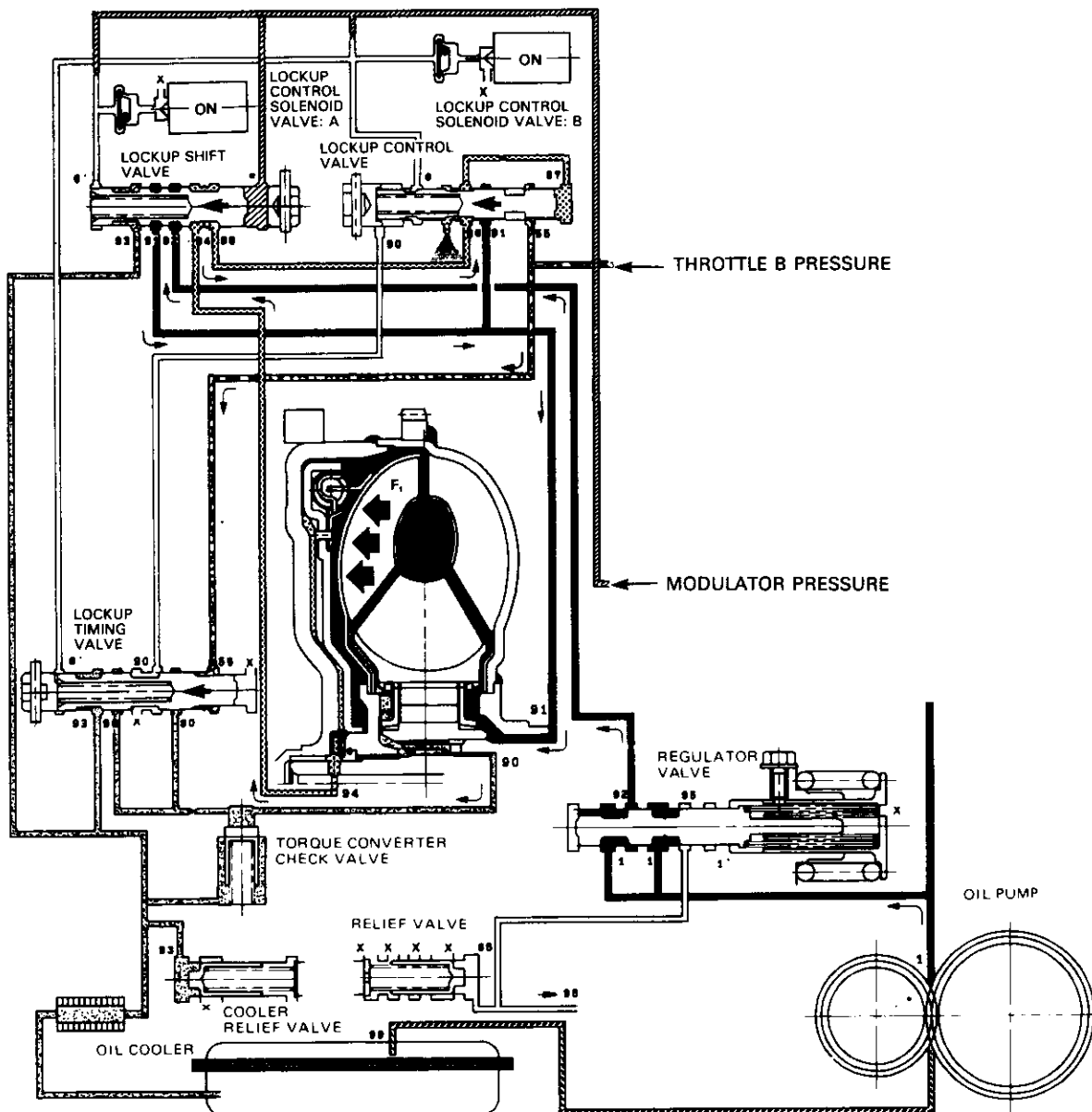



Deceleration Lock-up

Lock-up Control Solenoid Valve A: ON Lock-up Control Solenoid Valve B: Duty Operation (ON↔OFF)

The TCM switches solenoid valve B on and off rapidly under certain conditions. The slight lock-up and half lock-up regions are maintained so as to lock the torque converter properly.

NOTE:

When used, "left" or "right" indicates direction on the flowchart.

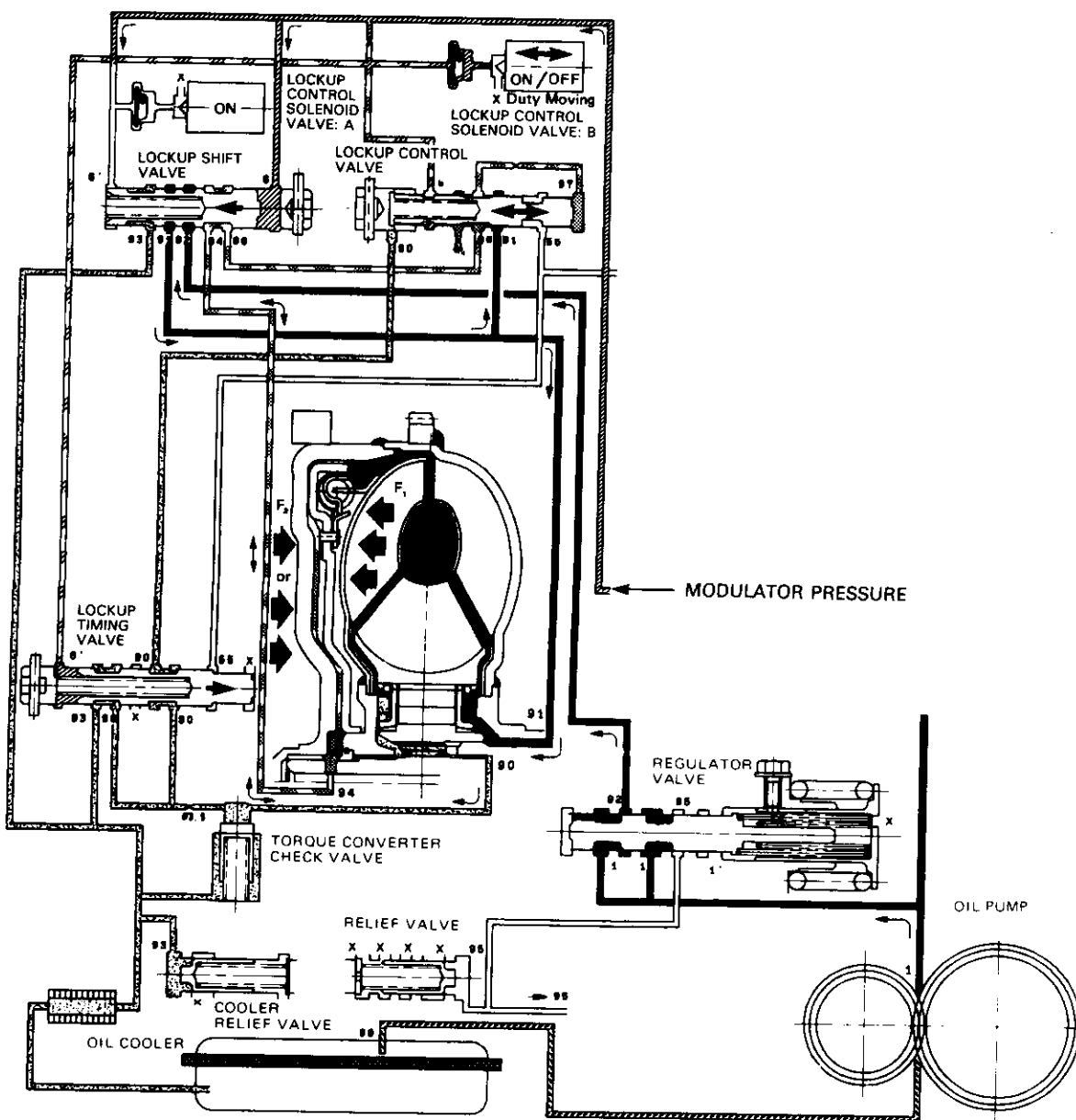

Description

Hydraulic Control

The valve body includes the main valve body, the regulator valve body, the throttle valve body, the secondary valve body, the servo body and the 1st/2nd accumulator body. The oil pump is driven by splines on the right end of the torque converter which is attached to the engine. Oil flows through the regulator valve to maintain specified pressure through the main valve body to the manual valve and the servo body, directing pressure to each of the clutches.

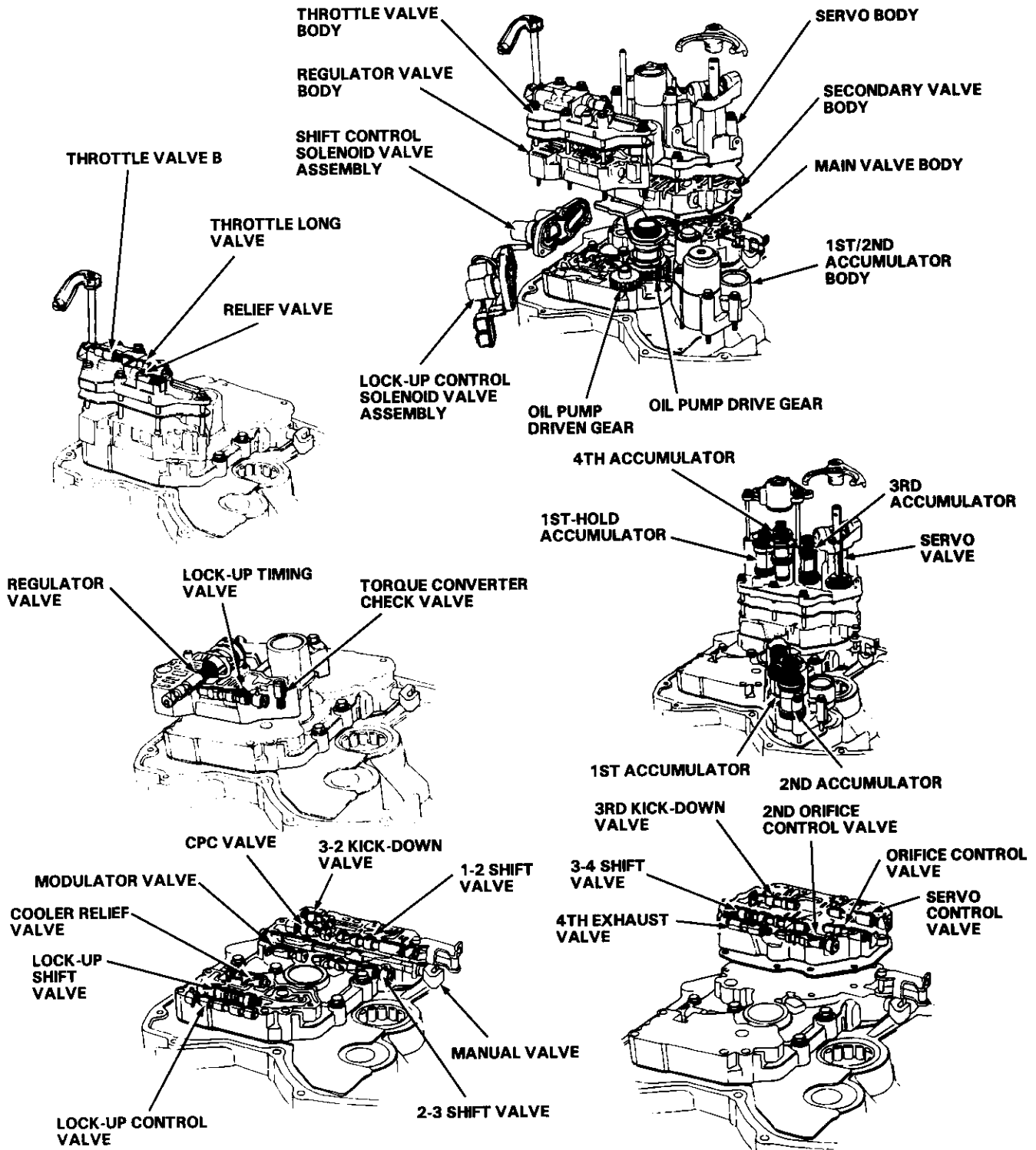



Regulator Valve

The regulator valve maintains a constant hydraulic pressure sent from the oil pump to the hydraulic control system, while also furnishing oil to the lubricating system and torque converter.

Oil flows through B and B'. The oil which enters through B flows through the valve orifice to A, pushing the regulator valve to the right. According to the level of hydraulic pressure through B, the position of the valve changes, and the amount of the oil through B' from D also changes. This operation is continued, maintaining line pressure.

(ENGINE NOT RUNNING)

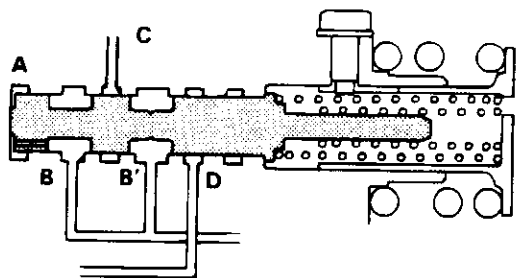

(ENGINE RUNNING)

To TORQUE CONVERTER

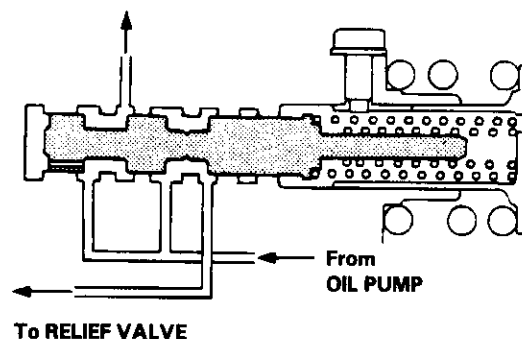

Stator Reaction Hydraulic Pressure Control

Hydraulic pressure increase according to torque is performed by the regulator valve using stator torque reaction. The stator shaft is splined in the stator, and its arm end contacts the regulator spring cap. When the car is accelerating or climbing (Torque Converter Range), stator torque reaction acts on the stator shaft, and the stator arm pushes the regulator spring cap in the → direction in proportion to the reaction. The stator reaction spring compresses, and the regulator valve moves to increase the regulated control pressure or line pressure. Line pressure is maximum when the stator reaction is maximum.

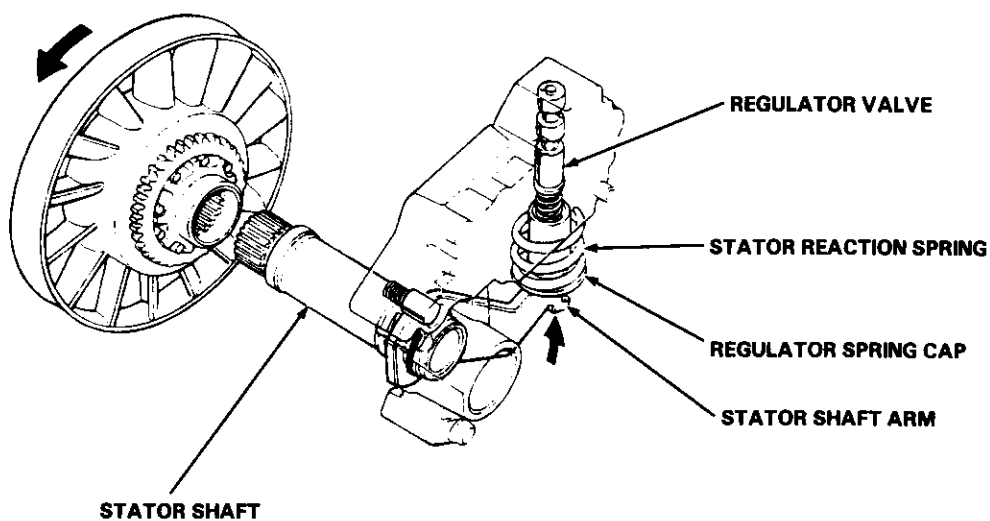

(cont'd)

Description

Hydraulic Control (cont'd)

Throttle Valve B

Throttle valve B converts changes in the throttle opening to changes in transmission hydraulic pressure. The end of throttle valve B contacts the throttle cam which is connected by a cable to the throttle body. The cable pulls the cam which, in turn, moves the throttle valve B. The throttle valve B-to-cam engagement is adjustable for shift smoothness and lock-up. Throttle valve B controls the accumulators, to make smooth changes from one gear to another. An assist function is used to lessen the throttle load.

Modulator Valve

The modulator valve maintains line pressure from the regulator, to the pressure shift control solenoid valves A/B and lock-up control solenoid valves A/B, thus maintaining accurate shift and lock-up characteristics.

2nd Orifice Control Valve

For smooth shifting between 2nd and 3rd, the 2nd orifice control valve relieves the 2nd clutch pressure. As 3rd clutch pressure is increased, the 2nd orifice control valve moves to uncover the oil port relieving the 2nd clutch pressure.

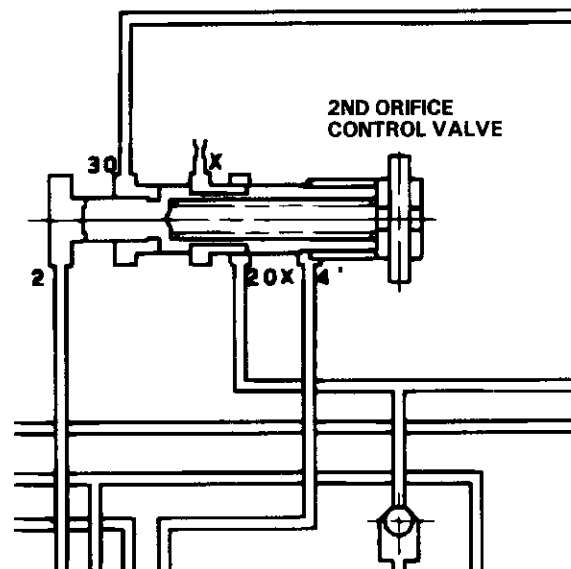

Component Location

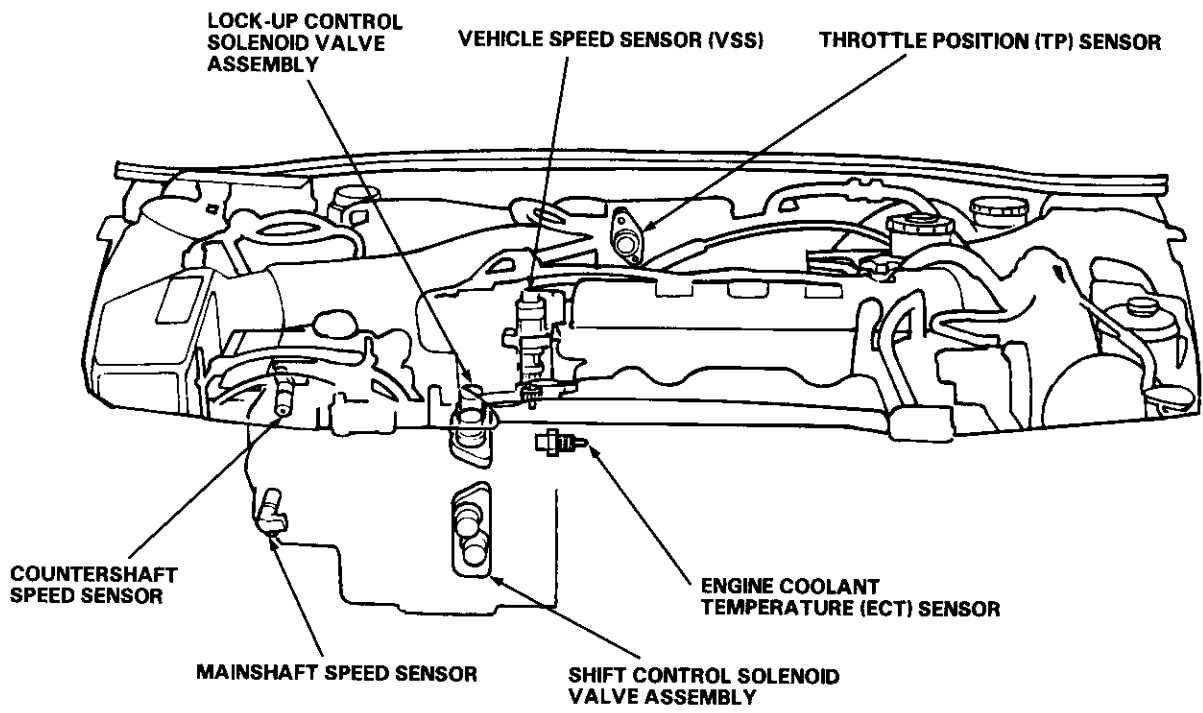
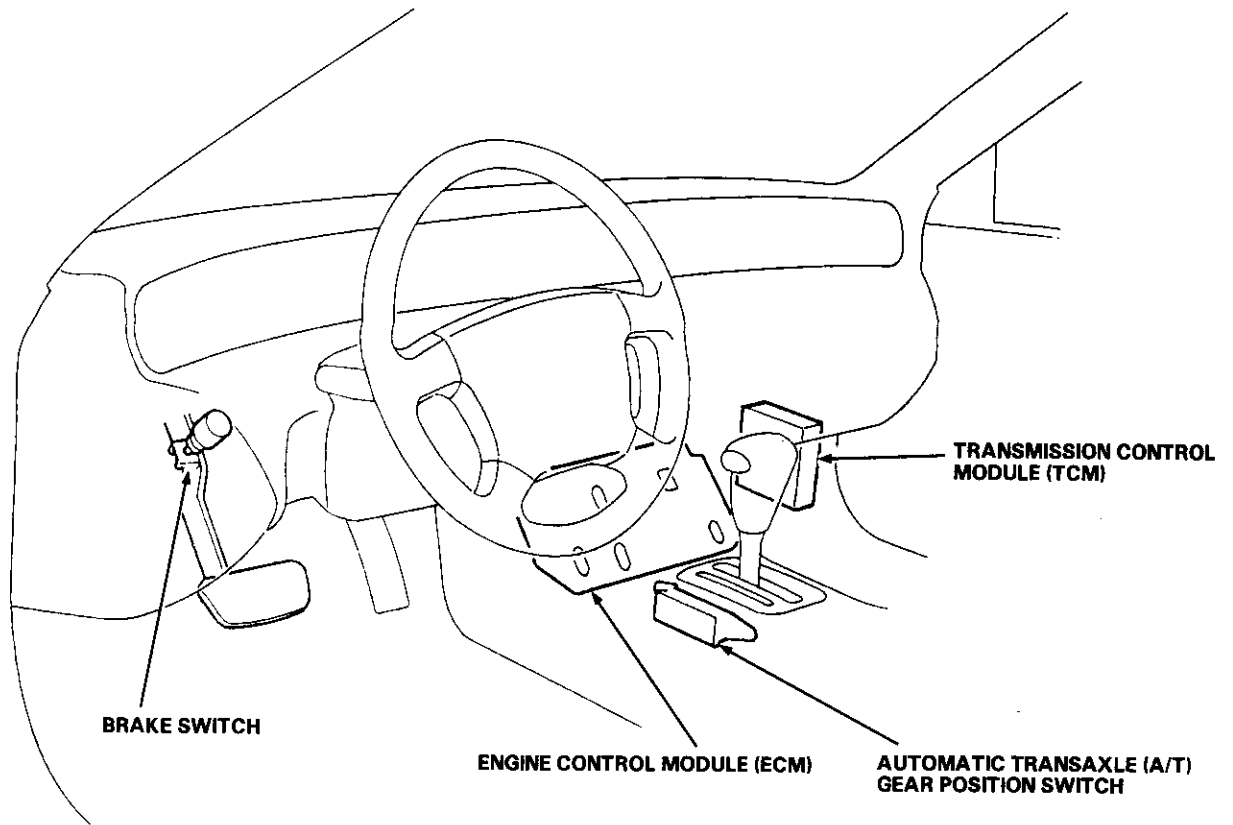

Circuit Diagram

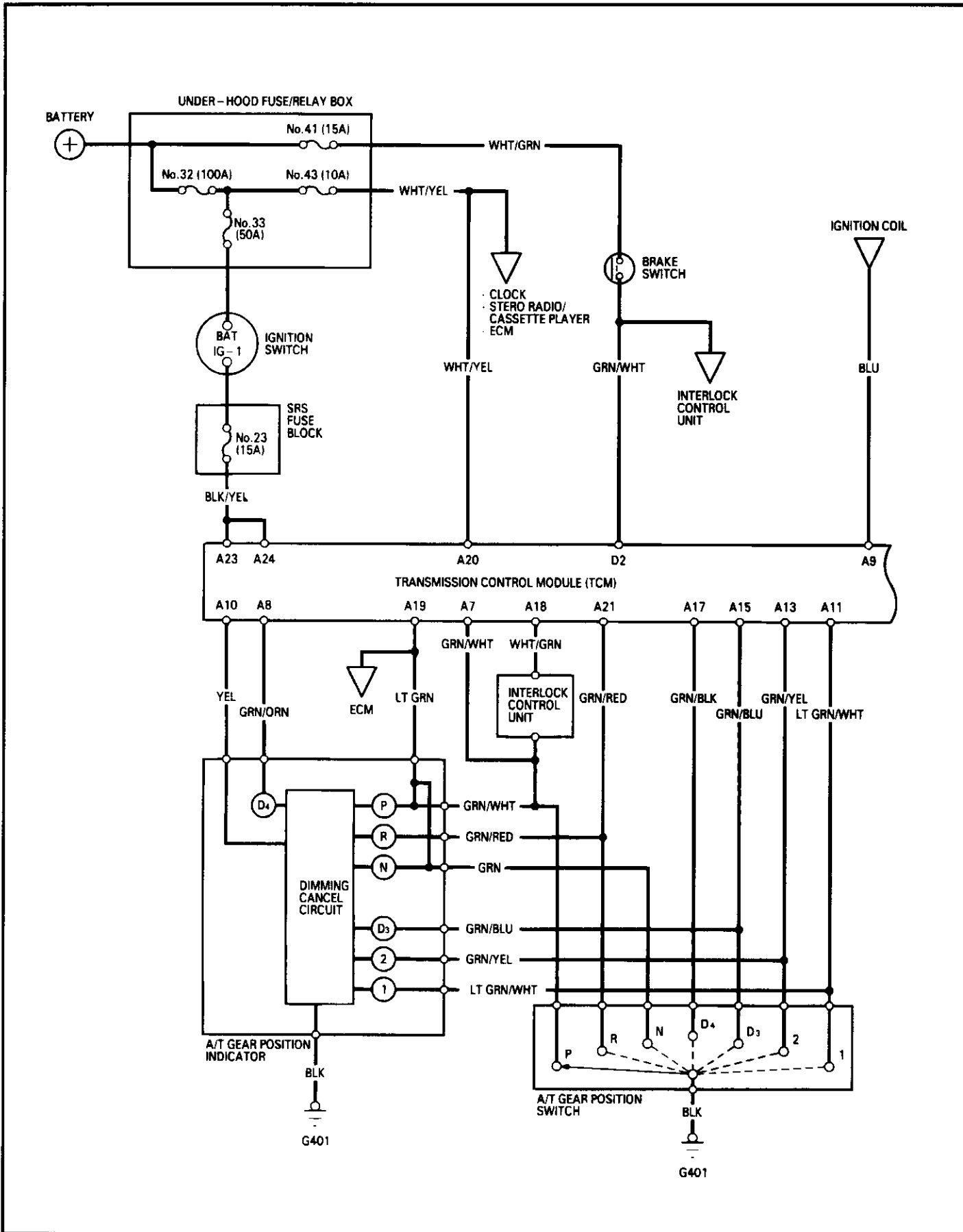

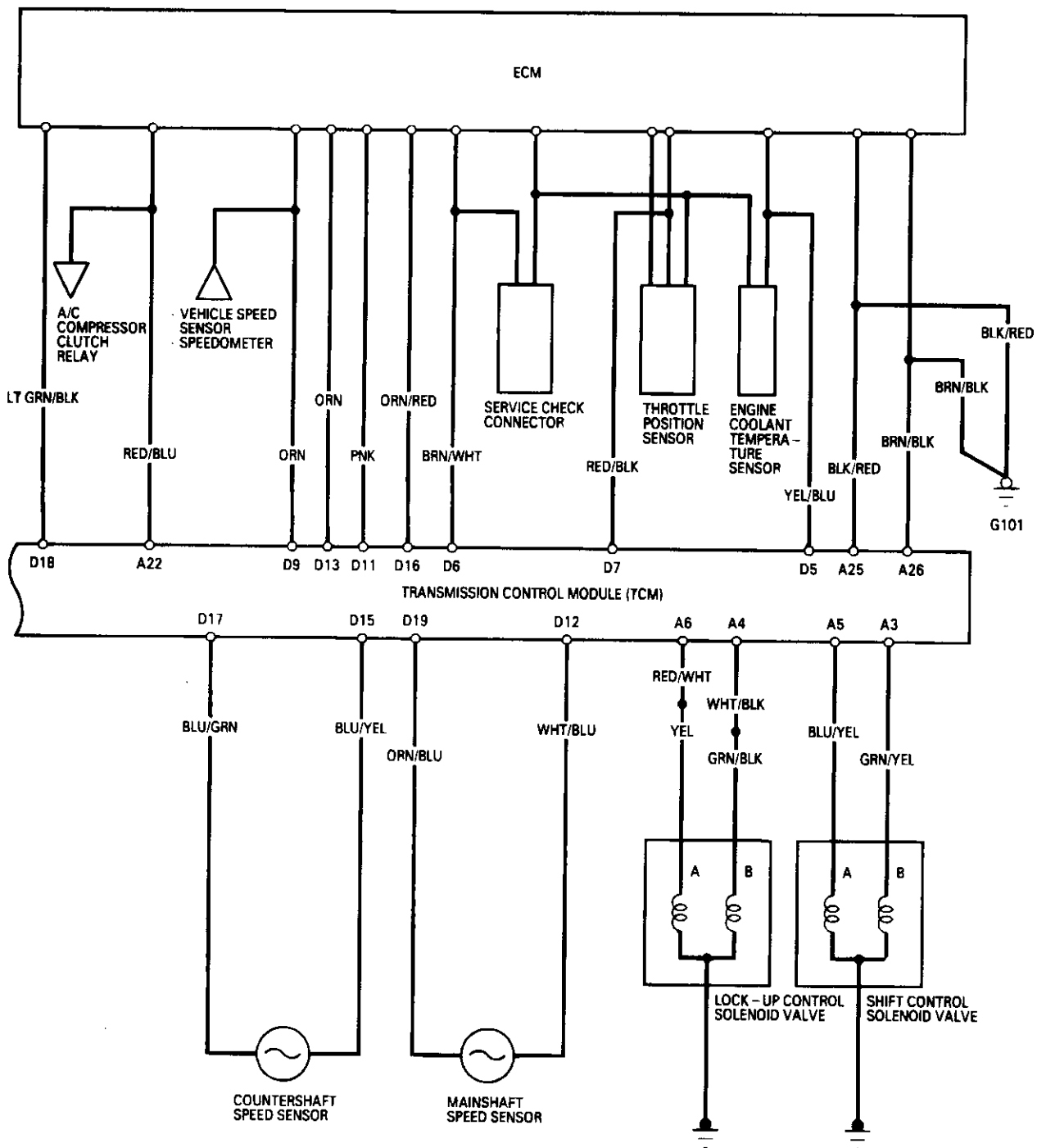

A3	A5	A7	A9	A11	A13	A15	A17	A19	A21	A23	A25
A4	A6	A8	A10				A18	A20	A22	A24	A26

	D5	D7	D9	D11	D13	D15	D17	D19
D2	D6			D12		D16	D18	

TCM Terminal Locations

Troubleshooting Procedures

When the TCM senses an abnormality in the input or output systems, the **D4** indicator light in the gauge assembly will blink. When the Service Check Connector (located behind the center console) is connected with a jumper wire, the **D4** indicator light will blink the Diagnostic Trouble Code (DTC) when the ignition switch is turned on.

When the **D4** indicator light has been reported on, connect the two terminals of the Service Check Connector together with a jumper wire.

Then turn on the ignition switch and observe the **D4** indicator light.

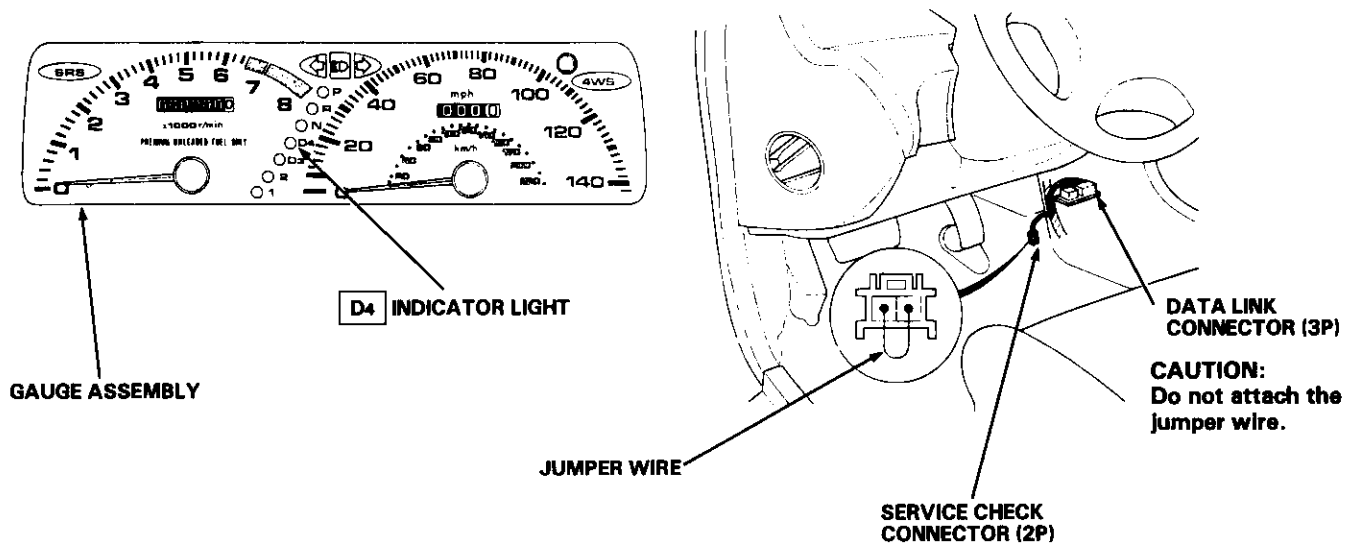

Codes 1 through 9 are indicated by individual short blinks, codes 10 through 15 are indicated by a series of long and short blinks. One long blink equals 10 short blinks. Add the long and short blinks together to determine the code. After determining the code, refer to the electrical system Symptom-to-Component Chart on pages 14-36 and 37.

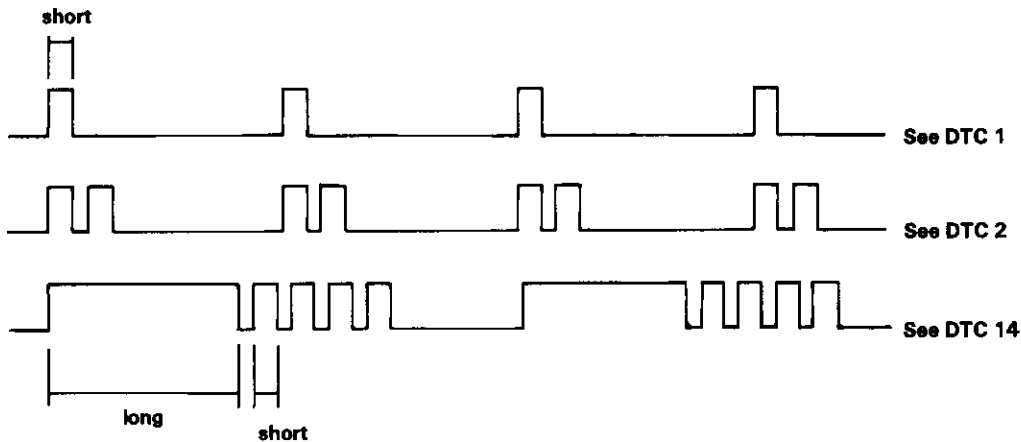

Some PGM-FI problems will also make the **D4** indicator light come on. After repairing the PGM-FI system, disconnect the CLOCK RADIO fuse (10A) in the under-hood fuse/relay box for more than 10 seconds to reset the TCM memory.

NOTE:

- PGM-FI system
The PGM-FI system on this model is a sequential multiport fuel injection system.
- Disconnecting the CLOCK RADIO fuse also cancels the radio anti-theft code, preset stations and the clock setting. Get the customer's code number and make note of the radio presets before removing the fuse so you can reset them.



CAUTION:

- All SRS electrical wiring harnesses are covered with yellow outer insulation.
- Before disconnecting the SRS wire harness, install the short connector(s) on the airbag(s) (see section 23).
- Replace the entire affected SRS harness assembly if it has an open circuit or damaged wiring.

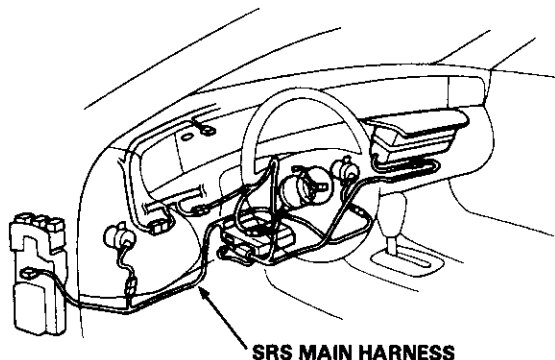

If the inspection for a particular failure code requires the use of Test Harness (07LAJ-PT3010A):

1. Remove the right door sill molding, door trim and right side kick panel (see section 20).
2. Pull the carpet back to expose the TCM.
3. Connect the wire harness to the Test Harness, and/or connect the Test Harness to the TCM according to the troubleshooting flowchart.

NOTE:

- Only the A and D terminals of the Test Harness are used for A/T troubleshooting.
- Unless otherwise noted, use only the Digital Multimeter, KS-AHM-32-003, for testing.

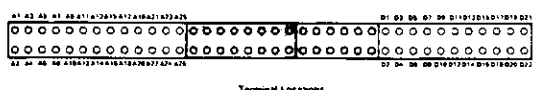
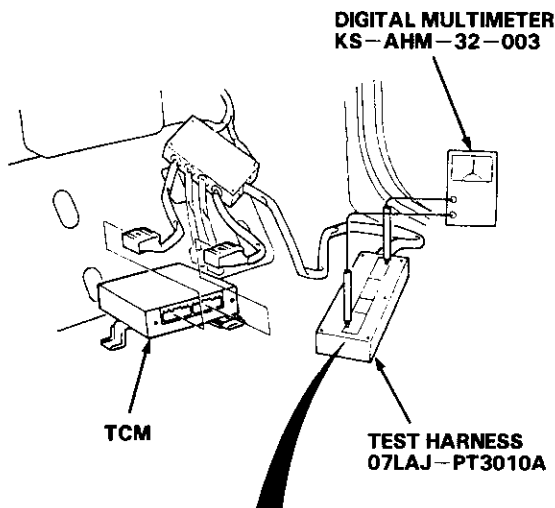

• **TCM Reset Procedure**

1. Turn the ignition switch off.
2. Remove the No. 43 CLOCK RADIO fuse (10A) from the under-hood fuse/relay box for 10 seconds to reset the TCM.

NOTE:

Disconnecting the No. 43 CLOCK RADIO fuse also cancels the radio anti-theft code, preset stations and the clock setting. Get the customer's code number and make note of the radio presets before removing the fuse so you can reset them.

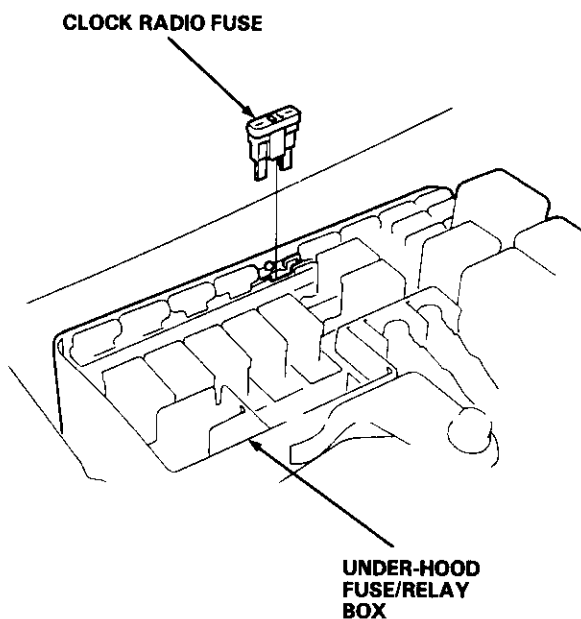

• **Final Procedure**

NOTE:

This procedure must be done after any troubleshooting.

1. Remove the jumper wire from the Service Check Connector.
2. Reset the TCM.
3. Set the radio preset stations and clock setting.

Symptom-to-Component Chart

Electrical System

Number of D4 indicator light blinks while Service Check Connector is jumped.	D4 indicator light	Possible Cause	Symptom	Refer to page
1	Blinks	<ul style="list-style-type: none"> • Disconnected lock-up control solenoid valve A connector • Short or open in lock-up control solenoid valve A wire • Faulty lock-up control solenoid valve A 	<ul style="list-style-type: none"> • Lock-up clutch does not engage. • Lock-up clutch does not disengage. • Unstable idle speed. 	14-38
2	Blinks	<ul style="list-style-type: none"> • Disconnected lock-up control solenoid valve B connector • Short or open in lock-up control solenoid valve B wire • Faulty lock-up control solenoid valve B 	<ul style="list-style-type: none"> • Lock-up clutch does not engage. 	14-39
3	Blinks or OFF	<ul style="list-style-type: none"> • Disconnected throttle position (TP) sensor connector • Short or open in TP sensor wire • Faulty TP sensor 	<ul style="list-style-type: none"> • Lock-up clutch does not engage. 	14-40
4	Blinks	<ul style="list-style-type: none"> • Disconnected vehicle speed sensor (VSS) connector • Short or open in VSS wire • Faulty VSS 	<ul style="list-style-type: none"> • Lock-up clutch does not engage. 	14-41
5	Blinks	<ul style="list-style-type: none"> • Short in A/T gear position switch wire • Faulty A/T gear position switch 	<ul style="list-style-type: none"> • Fails to shift other than 2nd↔4th gears. • Lock-up clutch does not engage. 	14-42
6	OFF	<ul style="list-style-type: none"> • Disconnected A/T gear position switch connector • Open in A/T gear position switch wire • Faulty A/T gear position switch 	<ul style="list-style-type: none"> • Fails to shift other than 2nd↔4th gears. • Lock-up clutch does not engage. • Lock-up clutch engages and disengages alternately. 	14-44
7	Blinks	<ul style="list-style-type: none"> • Disconnected shift control solenoid valve A connector • Short or open in shift control solenoid valve A wire • Faulty shift control solenoid valve A 	<ul style="list-style-type: none"> • Fails to shift (between 1st↔4th, 2nd↔4th or 2nd↔3rd gears only). • Fails to shift (stuck in 4th gear) 	14-46
8	Blinks	<ul style="list-style-type: none"> • Disconnected shift control solenoid valve B connector • Short or open in shift control solenoid valve B wire • Faulty shift control solenoid valve B 	<ul style="list-style-type: none"> • Fails to shift (stuck in 1st or 4th gears). 	14-47
9	Blinks	<ul style="list-style-type: none"> • Disconnected countershaft speed sensor connector • Short or open in the countershaft speed sensor wire • Faulty countershaft speed sensor 	<ul style="list-style-type: none"> • Lock-up clutch does not engage. 	14-48



Number of D4 indicator light blinks while Service Check Connector is jumped.	D4 indicator light	Possible Cause	Symptom	Refer to page
10	Blinks	<ul style="list-style-type: none"> • Disconnected engine coolant temperature (ECT) sensor connector • Short or open in ECT sensor wire • Faulty ECT sensor 	• Lock-up clutch does not engage.	14-50
11	OFF	<ul style="list-style-type: none"> • Disconnected ignition coil connector • Short or open in ignition coil wire • Faulty ignition coil 	• Lock-up clutch does not engage.	14-51
14	OFF	<ul style="list-style-type: none"> • Short or open in FAS (ORN/RED) wire between the D16 terminal and ECM • Trouble in ECM 	• Transmission jerks hard when shifting.	14-52
15	OFF	<ul style="list-style-type: none"> • Disconnected mainshaft speed sensor connector • Short or open in mainshaft speed sensor wire • Faulty mainshaft speed sensor 	• Transmission jerks hard when shifting.	14-54

If the self-diagnosis **D4** indicator light does not blink, perform an inspection according to the table below.

Symptom	Probable Cause	Ref. page
D4 indicator light does not come on for 2 seconds after ignition is first turned on.	_____	14-56
D4 indicator light is on steady, not blinking whenever the ignition is on.	_____	14-58
Lock-up clutch does not have duty operation (ON-OFF).	Check A/C signal with A/C on.	14-59
Lock-up clutch does not engage.		
Shift lever cannot be moved from P position with the brake pedal depressed.	Check brake switch signal.	14-60

- If a customer describes the symptoms for codes 3, 6, or 11, yet the **D4** indicator light is not blinking, it will be necessary to recreate the symptom by test driving, and then checking the **D4** indicator light with the ignition still ON.
- If the **D4** indicator light displays codes other than those listed above or stays lit continuously, the TCM is faulty.
- Sometimes the **D4** indicator light and the Malfunction Indicator Lamp (MIL)/Check Engine light may come on simultaneously. If so, check the PGM-FI system according to the number of blinks on the MIL/Check Engine light, then reset the memory by removing the CLOCK RADIO fuse in the under-hood fuse/relay box for more than 10 seconds. Drive the vehicle for several minutes at speed over 30 mph (50 km/h), then recheck the MIL/Check Engine light.

NOTE:

- PGM-FI system
The PGM-FI system on this model is a sequential multiport fuel injection system.
- Disconnecting the CLOCK RADIO fuse also cancels the radio anti-theft code, preset stations and the clock setting. Get the customer's code number and make note of the radio presets before removing the fuse so you can reset them.

Electrical Troubleshooting

Troubleshooting Flowchart

Self-diagnosis **D4** indicator light blinks once.

Disconnect the 26 P connector from the TCM.

Turn the ignition switch ON.

Measure the voltage between the A6 (RED/WHT) and A25 (BLK/RED) or A26 (BRN/BLK) terminals.

Is there voltage?

Possible Cause

- Disconnected lock-up control solenoid valve A connector
- Short or open in lock-up control solenoid valve A wire
- Faulty lock-up control solenoid valve A

Repair short to power source in RED/WHT wire between the A6 terminal and the lock-up control solenoid valve A.

Turn the ignition switch OFF.

Measure the resistance between the A6 (RED/WHT) and A25 (BLK/RED) or A26 (BRN/BLK) terminals.

Is the resistance 12–24 Ω?

Check for loose TCM connectors. If necessary, substitute a known-good solenoid valve assembly or TCM and recheck.

Disconnect the 2P connector from the lock-up control solenoid valve assembly.

Check for continuity between the A6 (RED/WHT) and A25 (BLK/RED) or A26 (BRN/BLK) terminals.

Is there continuity?

Repair short to ground in RED/WHT wire between the A6 terminal and the lock-up control solenoid valve A.

Measure the resistance of the solenoid at the 2P connector (14-62).

Is the resistance 12–24 Ω?

Check for open in RED/WHT wire between the A6 terminal and the lock-up control solenoid valve A.

Replace the lock-up control solenoid valve assembly.

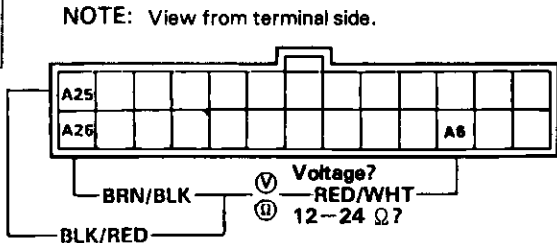



Self-diagnosis **D4** indicator light blinks twice.

Disconnect the 26 P connector from the TCM.

Turn the ignition switch ON.

Measure the voltage between the A4 (WHT/BLK) and A25 (BLK/RED) or A26 (BRN/BLK) terminals.

Is there voltage?

YES
Repair short to power source in WHT/BLK wire between the A4 terminal and the lock-up control solenoid valve B.

NO
Turn the ignition switch OFF.

Measure the resistance between the A4 (WHT/BLK) and A25 (BLK/RED) or A26 (BRN/BLK) terminals.

Is the resistance 12-24 Ω?

YES
Check for loose TCM connectors. If necessary, substitute a known-good solenoid valve assembly or TCM and recheck.

NO
Disconnect the 2P connector from the lock-up control solenoid valve assembly.

Check for continuity between the A4 (WHT/BLK) and A25 (BLK/RED) or A26 (BRN/BLK) terminals.

Is there continuity?

YES
Repair short to ground in WHT/BLK wire between the A4 terminal and the lock-up control solenoid valve B.

NO
Measure the resistance of the solenoid at the 2P connector (14-62).

Is the resistance 12-24 Ω?

YES
Check for open in WHT/BLK wire between the A4 terminal and the lock-up control solenoid valve B.

NO
Replace the lock-up control solenoid valve assembly.

Possible Cause

- Disconnected lock-up control solenoid valve B connector
- Short or open in lock-up control solenoid valve B wire
- Faulty lock-up control solenoid valve B

NOTE: View from terminal side.

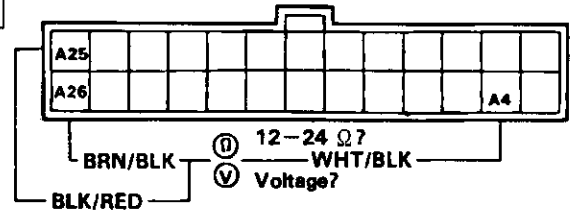

(cont'd)

Electrical Troubleshooting

Troubleshooting Flowchart (cont'd)

Self-diagnosis D4 Indicator light blinks three times.

Possible Cause

- Disconnected throttle position (TP) sensor connector
- Short or open in TP sensor wire
- Faulty TP sensor

Turn the ignition switch ON.

Check whether the Malfunction Indicator Lamp (MIL) blinks (see section 11).

Is the MIL blinking?

Repair the PGM-FI System (see section 11).

Turn the ignition switch OFF.

Disconnect the 26P and 22P connectors from the TCM. Connect the Test Harness "A" and "D" connectors to the wire harness only, not to the TCM (14-35).

Turn the ignition switch ON.

Measure the voltage between the D18 and A25/A26 terminals.

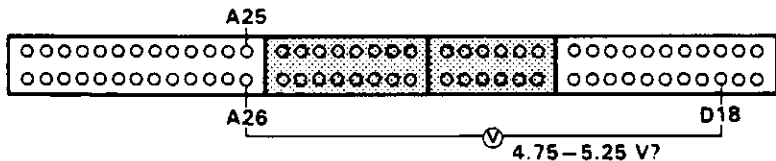

Is the voltage 4.75–5.25 V?

Repair open or short in LT GRN/BLK wire between the D 18 terminal and the ECM.

Turn the ignition switch OFF.

Connect the Test Harness "A" and "D" connectors to the TCM.

Turn the ignition switch ON.

Measure the voltage between the D7 and A25/A26 terminals.

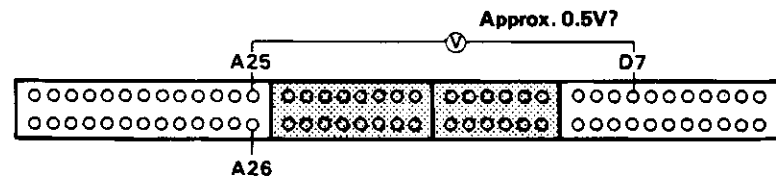

Is the voltage approx. 0.5 V?

Repair open or short in RED/BLK wire between the D7 terminal and the TP sensor.

Check for loose TCM connectors. If necessary, substitute a known-good TCM and recheck.



Self-diagnosis **D4** indicator light blinks four times.

Possible Cause
• Disconnected vehicle speed sensor (VSS) connector
• Short or open in VSS wire
• Faulty VSS

Does the speedometer operate?

NO
Refer to Section 23 for vehicle speed sensor (VSS) test.

YES

Raise the car.

▲ WARNING

- Make sure lifts, jacks, and safety stands are placed properly (see section 1).
- Set the parking brake securely and block the rear wheels.
- Jack up the front of the car and support with safety stands.

Shift transmission to **N** position.

Disconnect the 26P and 22P connectors from the TCM. Connect the Test Harness "A" and "D" connectors to the wire harness only, not to the TCM (14-35).

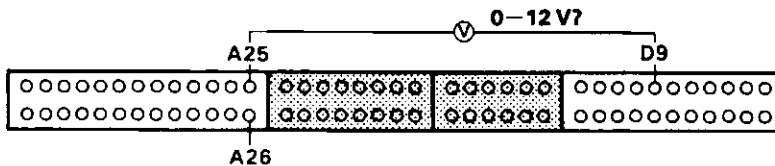

Turn the ignition switch ON.

Rotate the front wheel and check for voltage between the D9 and A25/A26 terminals. Block the other wheel so it does not turn.

Does the voltage 0-12 V appear alternately?

NO
Check for short or open in ORN wire between the D9 terminal and the VSS. If wire is OK, check the VSS (see section 23).

YES

Check for loose TCM connectors. If necessary, substitute a known-good TCM and recheck.

(cont'd)

Electrical Troubleshooting

Troubleshooting Flowchart (cont'd)

Self-diagnosis **D4** indicator light blinks five times.

Turn the ignition switch ON.

Observe the A/T gear position indicator, and select each position separately.

Possible Cause

- Short in A/T gear position switch wire
- Faulty A/T gear position switch

NOTE:
Code 5 is caused when the TCM receives two gear position inputs at the same time.

Do any indicators fail to light when shifted through all positions?

YES
See A/T gear position indicator inspection (see section 23).

NO
Turn the ignition switch OFF.

Connect the Test Harness between the TCM and connectors (14-35).

Turn the ignition switch ON.

Shift to other than **R** position.

Measure the voltage between the A21 and A25/A26 terminals.

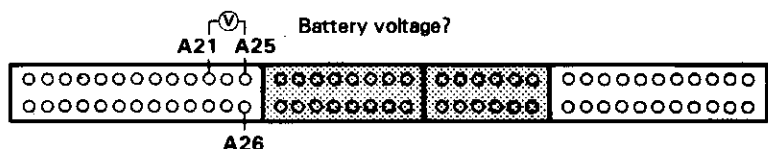

Is there battery voltage?

NO
Check for short in GRN/RED wire between the A21 terminal and the A/T gear position switch or A/T gear position indicator. If wire is OK, check for loose TCM connectors. If necessary, substitute a known-good TCM and recheck.

YES
Shift to other than **N** and **P** position.

Measure the voltage between the A19 and A25/A26 terminals.

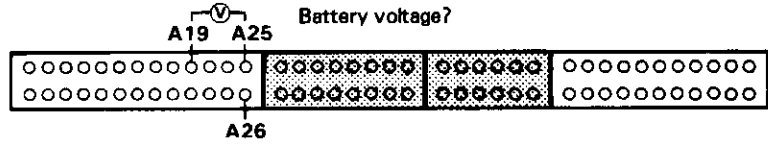

Is there battery voltage?

NO
Check for short in LT GRN wire between the A19 terminal and the A/T gear position indicator or a short in GRN/WHT or GRN wires between the A/T gear position indicator and the A/T gear position switch. If wire is OK, check for loose TCM connectors. If necessary, substitute a known-good TCM and recheck.

YES

To page 14-43



From page 14-42

Shift to other than **D4** position.

Measure the voltage between the A17 and A25/A26 terminals.

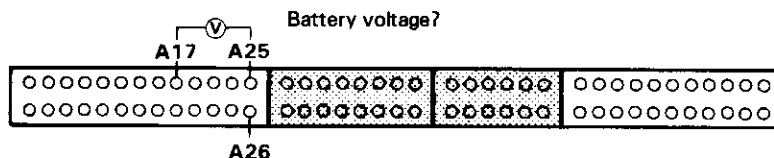

Is there battery voltage? **NO**

Check for short in GRN/BLK wire between the A17 terminal and the A/T gear position switch. If wire is OK, check for loose TCM connectors. If necessary, substitute a known-good TCM and recheck.

Shift to other than **D3** position.

Measure the voltage between the A15 and A25/A26 terminals.

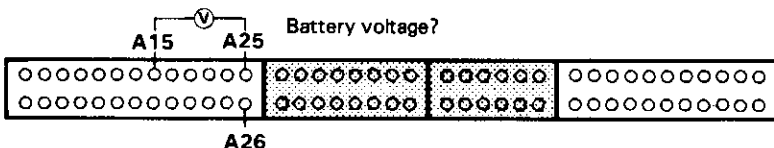

Is there battery voltage? **NO**

Check for short in GRN/BLU wire between the A15 terminal and the A/T gear position switch or A/T gear position indicator. If wire is OK, check for loose TCM connectors. If necessary, substitute a known-good TCM and recheck.

Shift to other than **2** position.

Measure the voltage between the A13 and A25/A26 terminals.

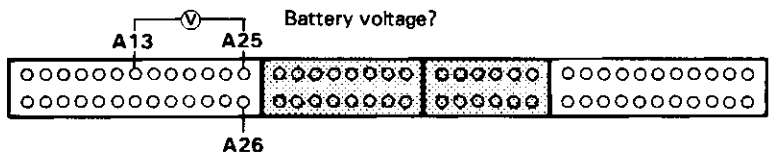

Is there battery voltage? **NO**

Check for short in GRN/YEL wire between the A13 terminal and the A/T gear position switch or A/T gear position indicator. If wire is OK, check for loose TCM connectors. If necessary, substitute a known-good TCM and recheck.

Shift to other than **1** position.

Measure the voltage between the A11 and A25/A26 terminals.

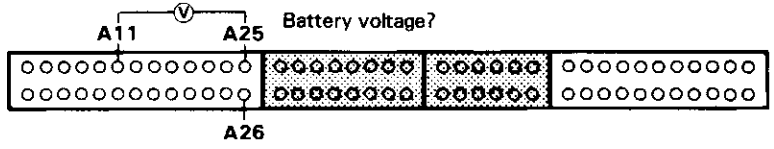

Is there battery voltage? **NO**

Check for short in LT GRN/WHT wire between the A11 terminal and the A/T gear position switch or A/T gear position indicator. If wire is OK, check for loose TCM connectors. If necessary, substitute a known-good TCM and recheck.

Check for loose TCM connectors. If necessary, substitute a known-good TCM and recheck.

(cont'd)

Electrical Troubleshooting

Troubleshooting Flowchart (cont'd)

Self-diagnosis **D4** indicator light blinks six times.

- | Possible Cause |
|---|
| • Disconnected A/T gear position switch connector |
| • Open in A/T gear position switch wire |
| • Faulty A/T gear position switch |

Connect the Test Harness between the TCM and connectors (14-35).

Turn the ignition switch ON.

Shift to **R** position.

Measure the voltage between the A21 and A25/A26 terminals.

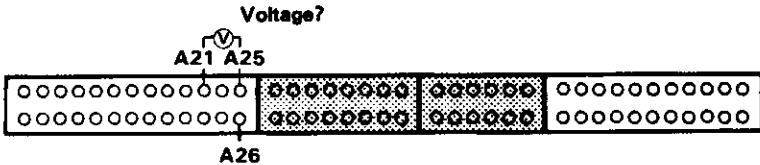

Is there voltage?

YES
Repair open in GRN/RED wire between the A21 terminal and the AT gear position switch.

NO

Shift to **N** or **P** position.

Measure the voltage between the A19 and A25/A26 terminals.

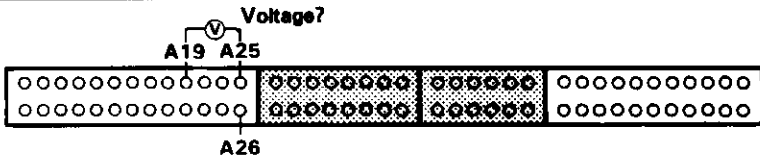

Is there voltage?

YES
Repair open in LT GRN wire between the A19 terminal and the A/T gear position indicator.

NO

To page 14-45



From page 14-44

Shift to **D4** position.

Measure the voltage between the A17 and A25/A26 terminals.

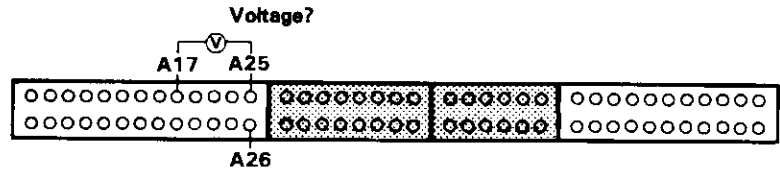

Is there voltage?

YES
Repair open in GRN/BLK wire between the A17 terminal and the A/T gear position switch.

NO

Shift to **D3** position.

Measure the voltage between the A15 and A25/A26 terminals.

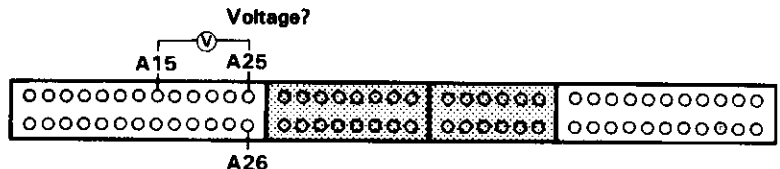

Is there voltage?

YES
Repair open in GRN/BLU wire between the A15 terminal and the A/T gear position switch.

NO

Shift to **2** position.

Measure the voltage between the A13 and A25/A26 terminals.

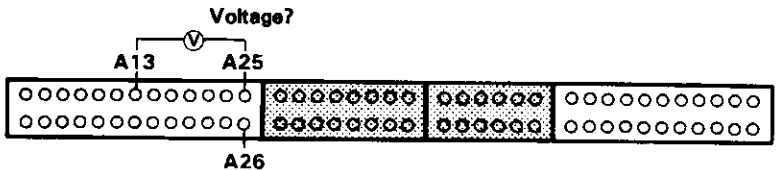

Is there voltage?

YES
Repair open in GRN/YEL wire between the A13 terminal and the A/T gear position switch.

NO

Shift to **1** position.

Measure the voltage between the A11 and A25/A26 terminals.

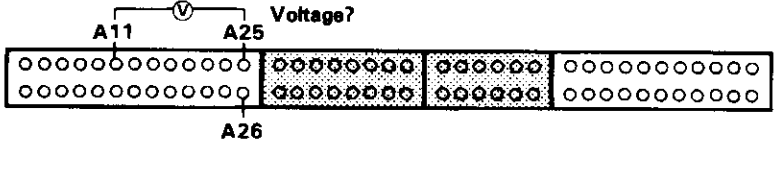

Is there voltage?

YES
Repair open in LT GRN/WHT wire between the A11 terminal and the A/T gear position switch.

NO

Check for loose TCM connectors. If necessary, substitute a known-good TCM and recheck.

(cont'd)

Electrical Troubleshooting

Troubleshooting Flowchart (cont'd)

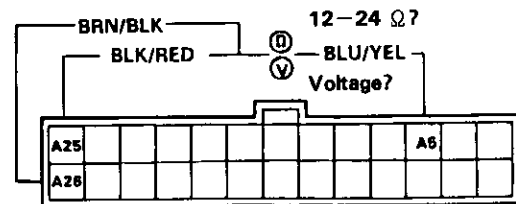
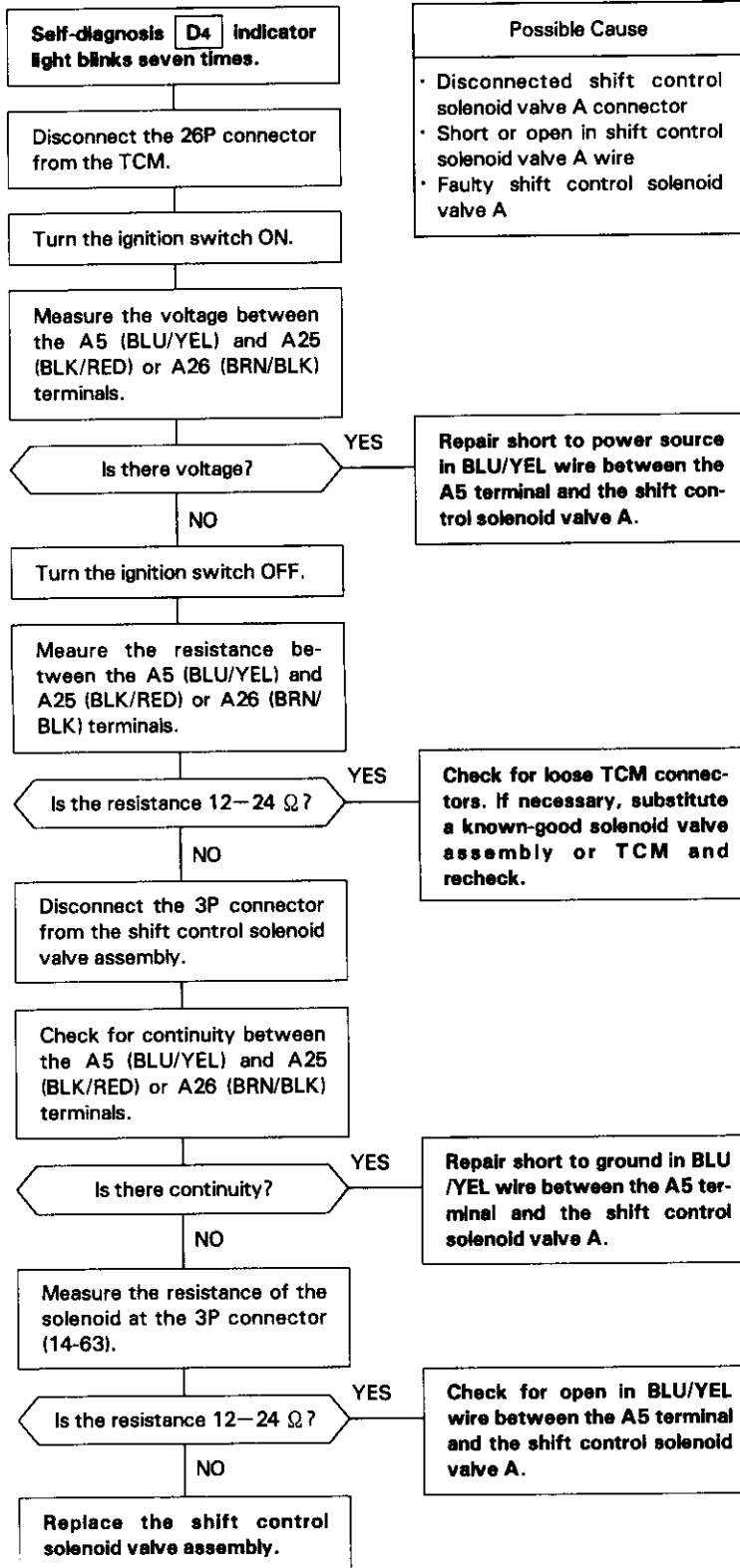

NOTE: View from terminal side.

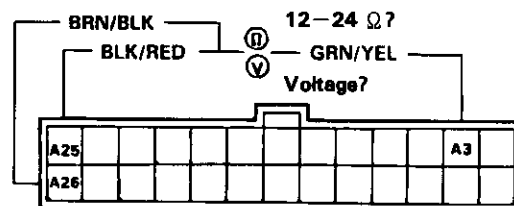
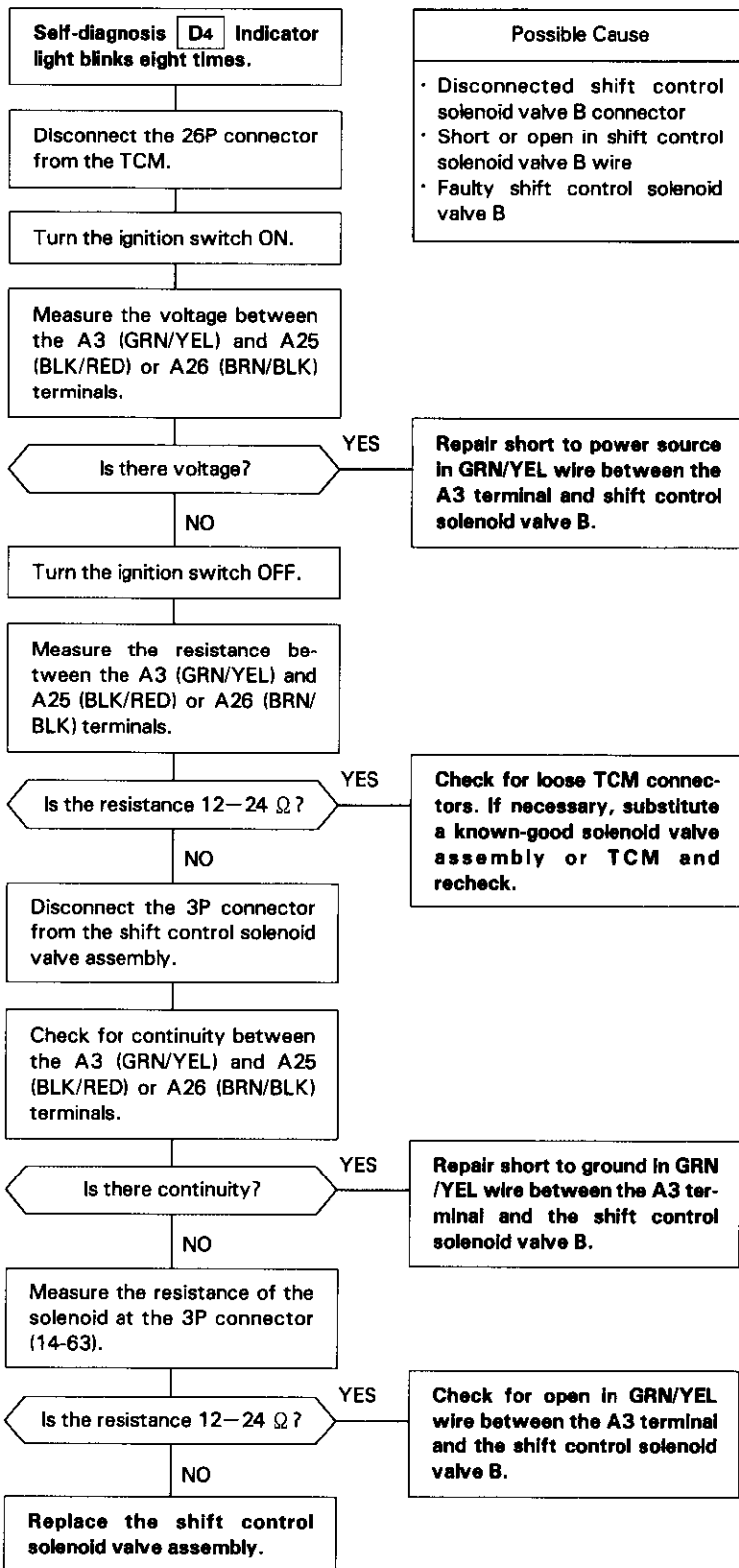

NOTE: View from terminal side.

(cont'd)

Electrical Troubleshooting

Troubleshooting Flowchart (cont'd)

Self-diagnosis **D4** Indicator light blinks nine times.

- Possible Cause
- Loose or faulty connection between the TCM and car harness.
 - Disconnected countershaft speed sensor connector
 - Short or open in the countershaft speed sensor wire
 - Faulty countershaft speed sensor

Is the countershaft speed sensor installed properly?

NO → Reinstall and recheck.

YES

Disconnect the 2P connector from the countershaft speed sensor connector.

Measure the resistance of the countershaft speed sensor.

Is the resistance 400–600 Ω? (at 70°F, 20°C)

NO → Replace the countershaft speed sensor.

YES

Disconnect the 22P connector from the TCM. Connect the Test Harness "D" connector to the wire harness only, not to the TCM (14-35).

Check for continuity between body ground and D17 terminal and D15 terminal individually.

Is there continuity?

YES → Repair short in BLU/GRN or BLU/YEL wire between D17 and D15 terminals and the countershaft speed sensor.

NO

Reconnect the countershaft speed sensor connector.

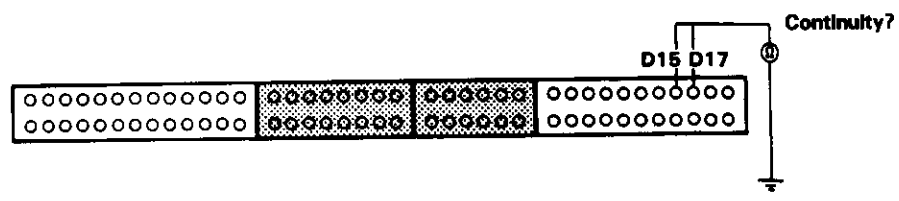

To page 14-49



From page 14-48

Measure the resistance between D17 and D15 terminals.

Is the resistance 400–600 Ω ?
(at 70°F, 20°C)

NO

Repair loose terminal or open in BLU/GRN or BLU/YEL wire between D17 and D15 terminals and the countershaft speed sensor.

YES

Check for loose TCM connector. If necessary, substitute a known-good TCM and recheck.

400–600 Ω ?



(cont'd)

Electrical Troubleshooting

Troubleshooting Flowchart (cont'd)

Self-diagnosis **D4** indicator light blinks ten times.

Turn the ignition switch ON.

Check whether the Malfunction Indicator Lamp (MIL) blinks (see section 11).

Is the MIL blinking?

YES
Repair the PGM-FI System (see section 11).

- Possible Cause
- Disconnected engine coolant temperature (ECT) sensor connector
 - Short or open in the ECT sensor wire
 - Faulty ECT sensor

NO
Turn the ignition switch OFF.

Disconnect the 26P and 22P connectors from the TCM. Connect the Test Harness "A" and "D" connectors to the wire harness only, not to the TCM(14-35).

Turn the ignition switch ON.

Measure the voltage between the D18 and A25/A26 terminals.

Is the voltage 4.75–5.25 V?

NO
Repair open or short in LT GRN/BLK wire between the D18 terminal and the ECM.

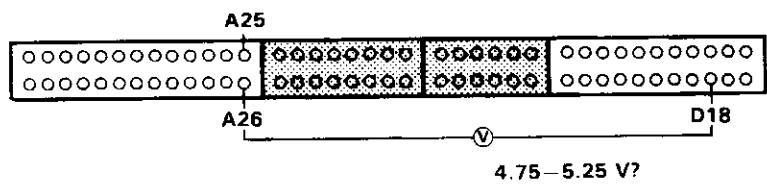

YES
Turn the ignition switch OFF.

Connect the Test Harness "A" and "D" connectors to the TCM.

Start the engine and warm it up to normal operating temperature (the radiator fan comes on).

Measure the voltage between the D5 and A25/A26 terminals.

Is the voltage less than 1V?

NO
Repair open or short in YEL/BLU wire between the D5 terminal and the ECT sensor.

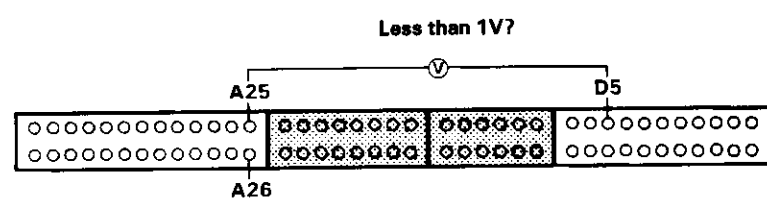

YES
Check for loose TCM connectors. If necessary, substitute a known-good TCM and recheck.



Self-diagnosis **D4** indicator light blinks eleven times.

Disconnect the 26P connector from the TCM.

Turn the ignition switch ON.

Measure the voltage between the A9 (BLU) and A25 (BLK/RED) or A26 (BRN/BLK) terminals.

Is there battery voltage?

YES

Check for loose TCM connectors. If necessary, substitute a known-good TCM and recheck.

Possible Cause

- Disconnected ignition coil connector
- Short or open in ignition coil wire
- Faulty ignition coil

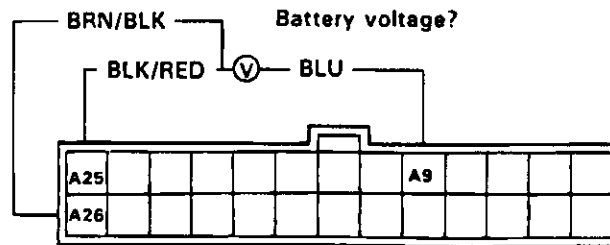

NOTE: View from terminal side.

NO

Repair open or short in BLU wire between the A9 terminal and the ignition coil.

(cont'd)

Electrical Troubleshooting

Troubleshooting Flowchart (cont'd)

Self-diagnosis **D4** indicator light blinks fourteen times.

Possible Cause

- Short or open in FAS (ORN/RED) wire
- Trouble in ECM

▲ WARNING

- Make sure lifts, jacks and safety stands are placed properly, and hoist brackets are attached to the correct position on the engine (see section 1).
- While testing, be careful of the rotating front wheels.

Is the Malfunction Indicator Lamp (MIL) on?

YES

Repair the PGM-FI System (see section 11).

NO

Start the engine and warm it up to normal operating temperature (the radiator fan comes on).

Shift to **P** position.

Turn the ignition switch OFF.

Connect the Test Harness between the TCM and connectors (14-35).

Turn the ignition switch ON and wait for at least two seconds.

Measure the voltage between the D16 (+) and A25/A26 (-) terminals.

Is there approx. 5V?

YES

Check for loose TCM connectors. If necessary, substitute a known-good TCM and recheck.

NO

Turn the ignition switch OFF.

Disconnect the Test Harness from the TCM. Leave connected to car harness.

Turn the ignition switch ON.

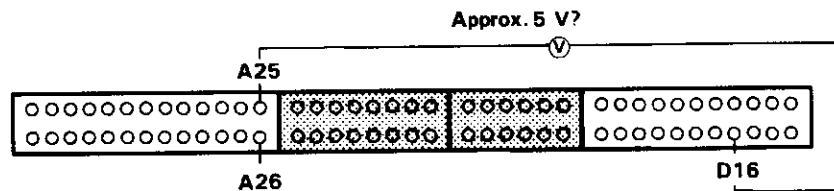

To page 14-53



From page 14-52

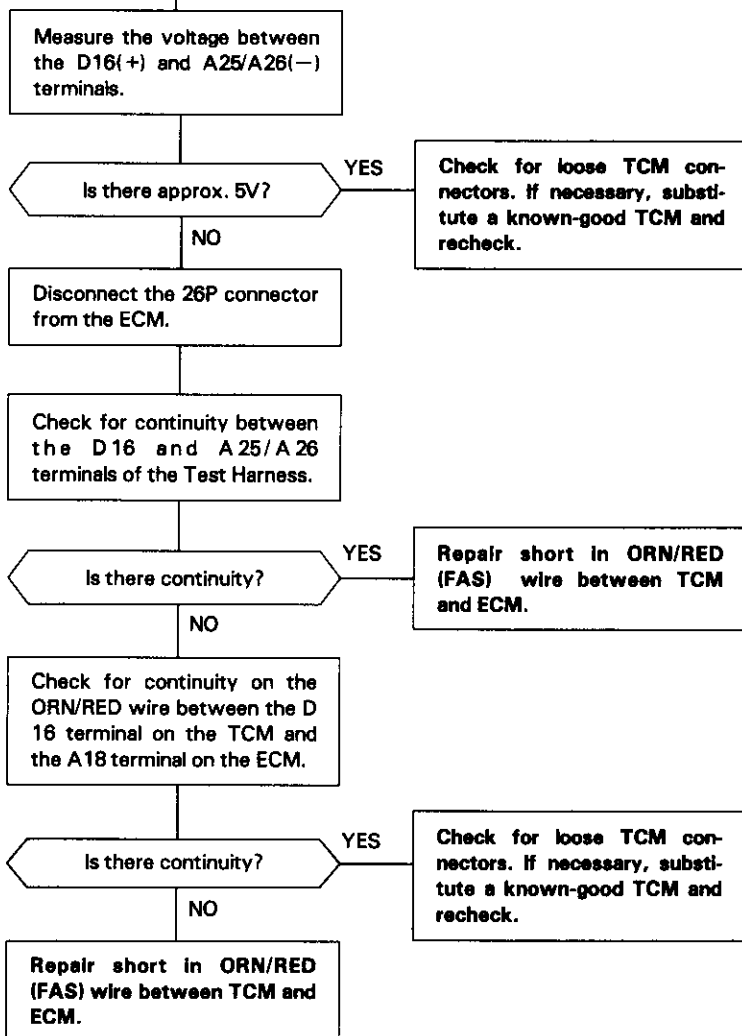

(cont'd)

Electrical Troubleshooting

Troubleshooting Flowchart (cont'd)

Self-diagnosis **D4** indicator light blinks fifteen times.

- Possible Cause**
- Disconnected mainshaft speed sensor connector
 - Short or open in mainshaft speed sensor wire
 - Faulty mainshaft speed sensor

NOTE:
A code 15 on the TCM doesn't always mean there's an electrical problem in the mainshaft or countershaft speed sensor circuit; code 15 may also indicate a mechanical problem in the transmission.

Are the mainshaft and countershaft speed sensors installed properly?

Reinstall and recheck.

Disconnect the 2P connector from the mainshaft speed sensor.

Measure the resistance of the mainshaft speed sensor.

Is the resistance 400–600 Ω ? (at 70°F, 20°C)

Replace the mainshaft speed sensor.

Disconnect the 22P connector from the TCM. Connect the Test Harness "D" connector to the wire harness only, not to the TCM (14-35).

Check the continuity between D19 and D12 terminals and body ground.

Is there continuity?

Repair short in ORN/BLU or WHT/BLU wires between D 19 and D12 terminals and the mainshaft speed sensor.

Reconnect the 2P connector to the mainshaft speed sensor.

To page 14-55

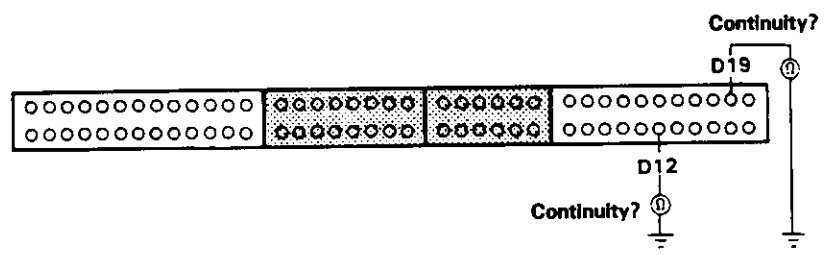



From page 14-54

Measure the resistance between D19 and D12 terminals.

Is the resistance 400–600 Ω ? (at 70°F, 20°C)

YES

Run Electrical Troubleshooting for code 9. Check for loose TCM connector. If necessary, substitute a known-good TCM and recheck.

NO

Check for continuity between D19 terminal and the mainshaft speed sensor.

Is there continuity?

NO

Repair open in ORN/BLU wire between D19 terminal and the mainshaft speed sensor.

YES

Check for continuity between D12 terminal and the mainshaft speed sensor.

Is there continuity?

NO

Repair open in WHT/BLU wire between D12 terminal and the mainshaft speed sensor.

YES

Check for loose TCM connectors. If necessary, substitute a known-good TCM and recheck.

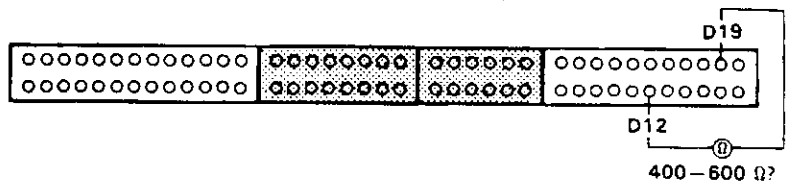

(cont'd)

Electrical Troubleshooting

Troubleshooting Flowchart (cont'd)

D4 Indicator light does not come on with the ignition switch ON. (It should come on for about 2 seconds.)

Is the service check connector jumped?

YES

Disconnect the jumper wire and recheck.

NO

Shift to **D4** position.

Does the **D4** indicator light come on?

YES

Check for loose TCM connectors. If necessary, substitute a known-good TCM and recheck.

NO

Turn the ignition switch OFF.

Disconnect the 26P connector from the TCM. Connect the Test Harness "A" connector to the wire harness only, not to the TCM (14-35).

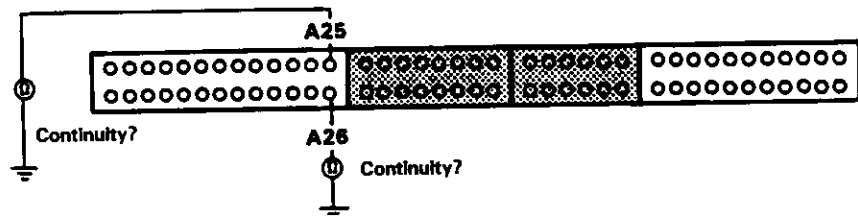

Check for continuity between the A25 terminal and body ground and A26 and body ground.

Is there continuity?

NO

Repair open BLK/RED or BRN/BLK wires between A25 or A26 terminals and G101.

YES

Turn the ignition switch ON.

Measure the voltage between the A23 or A24 and A25 or A26 terminals.

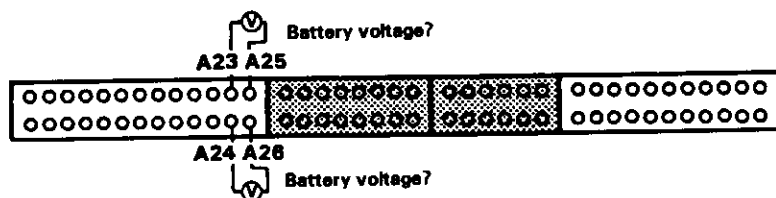

Is there battery voltage?

NO

Repair open or short in BLK/YEL wire between the A23 and/or A24 terminals and under-hood fuse/relay box.

YES

Turn the ignition switch OFF.

To page 14-57



From page 14-56

Connect the Test Harness "A" connector to the TCM.

Turn the ignition switch ON. Be sure that voltage is available for 2 seconds between the A8 terminal and A25/A26 terminal.

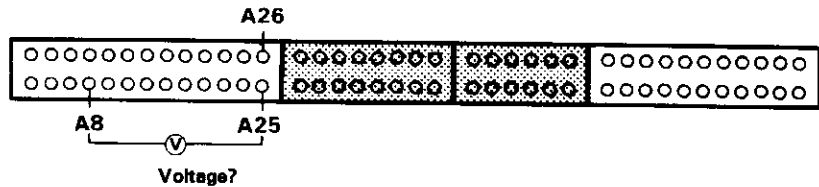

Is there voltage?

YES

Check for open or short in GRN/ORN wire between the A8 terminal and the gauge assembly.

NO

Turn the ignition switch OFF.

Disconnect the Test Harness "A" connector from the TCM.

Check for continuity between the A8 terminal and the GRN/ORN wire at the gauge assembly.

Is there continuity?

NO

Repair open in GRN/ORN wire between the A8 terminal and the gauge assembly.

YES

Check for loose TCM connectors. Check the A/T gear position switch. If necessary, substitute a known-good TCM and recheck.

(cont'd)

Electrical Troubleshooting

Troubleshooting Flowchart (cont'd)

D4 indicator light is on steady (not blinking) whenever the ignition switch is ON.

Turn the ignition switch OFF.

Disconnect the 26P connector from the TCM.
Connect the Test Harness "A" connector to the wire harness only, not to the TCM. (14-35).

Turn the ignition switch ON.

Measure the voltage between the A8 terminal and body ground.

Is there voltage? **YES** → Replace the TCM.

NO
Connect the Test Harness "A" connector to the TCM.

Measure the voltage between the GRN/ORN wire at the gauge assembly and to body ground.

Is there voltage? **NO** → Replace faulty A/T gear position indicator.

YES
Repair short to power source on GRN/ORN wire between A8 terminal and gauge assembly.

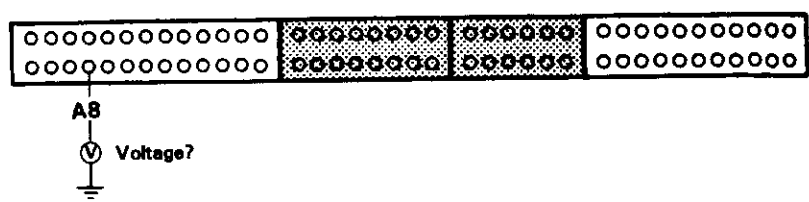



Inspection of the A/C signal.

Start the engine.

Turn the blower switch ON.

Push the A/C switch ON.

Does A/C compressor clutch engage?

NO

Symptom

- Lock-up clutch does not have duty operation (ON ↔ OFF).
- Lock-up clutch does not engage.

See Air Conditioning Inspection (see section 22).

YES

Stop the engine.

Disconnect the 26P connector from the TCM.

Start the engine.

Measure the voltage between the A22 (RED/BLU) and A25 (BLK/RED) or A26 (BRN/BLK) terminals. (A/C compressor OFF)

NOTE: View from terminal side.

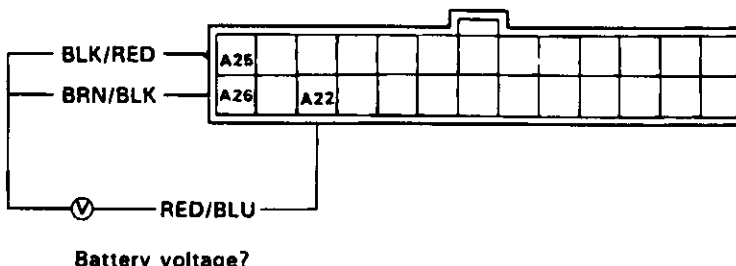

Is there battery voltage?

NO

Repair open in RED/BLU wire between the A22 terminal and A/C compressor clutch relay.

YES

- A/C signal is OK.
- Check for loose TCM connectors. If necessary, substitute a known-good TCM and recheck.
- Inspect the air conditioning (see section 22).

(cont'd)

Electrical Troubleshooting

Troubleshooting Flowchart (cont'd)

Inspection of the brake switch signal.	Symptom
Check that the brake lights come on with the brake pedal depressed.	Shift lever cannot be moved from P position with the brake pedal depressed.

Are brake lights ON?

NO → Repair faulty brake switch circuits.

YES →

Disconnect the 26P and 22P connectors from the TCM. Connect the Test Harness "A" and "D" connectors to the wire harness only, not to the TCM (14-35).

Measure the voltage between the D2 and A25/A26 terminals with the brake pedal depressed.

Is there battery voltage?

NO → Repair open in GRN/WHT wire between the D2 terminal and brake switch.

YES →

- Brake switch signal OK.
- Check for loose TCM connectors. If necessary, substitute a known-good TCM and recheck.
- Inspect the brake switch circuit (see section 23).

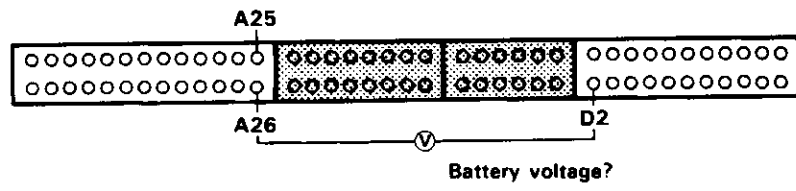

Mainshaft/Countershaft Speed Sensors



Replacement

1. Remove the 6 mm bolt from the transmission housing and remove the mainshaft and countershaft speed sensors.

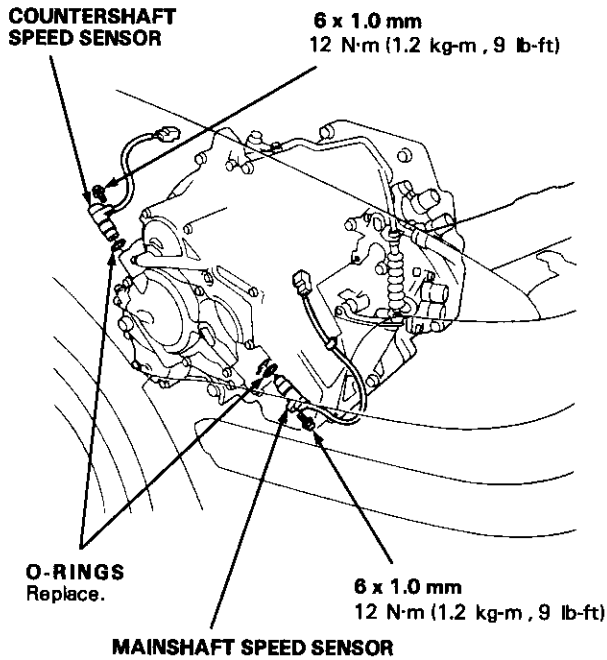

2. Replace the O-rings with a new one before reassembling the mainshaft and countershaft speed sensors.

Lock-up Control Solenoid Valve A/B

Test

NOTE:

Lock-up control solenoid valves A and B must be removed/replaced as an assembly.

1. Disconnect the connector from the lock-up control solenoid valve A/B.
2. Measure the resistance between the No. 1 terminal (solenoid valve A) of the lock-up control solenoid valve connector and body ground, and between the No. 2 terminal (solenoid valve B) and body ground.

STANDARD: 12–24 Ω

View from terminal side.

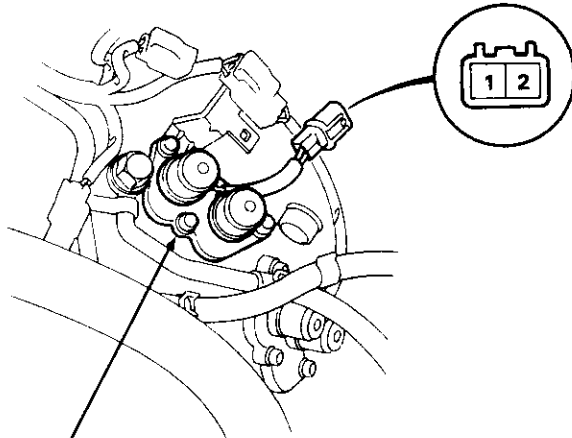

LOCK-UP CONTROL SOLENOID VALVE ASSEMBLY

3. Replace the lock-up control solenoid valve assembly if the resistance is out of specification.
4. If the resistance is within the standard, connect the No. 1 terminal of the lock-up control solenoid valve connector to the battery positive terminal. A clicking sound should be heard. Connect the No. 2 terminal to the battery positive terminal. A clicking sound should be heard. Replace the lock-up control solenoid valve assembly if no clicking sound is heard.

Replacement

1. Remove the mounting bolts and lock-up control solenoid valve assembly.

NOTE:

Be sure to remove or replace the lock-up control solenoid valves A and B as an assembly.

2. Check the lock-up control solenoid valve oil passages for dust or dirt, and replace as an assembly, if necessary.

LOCK-UP CONTROL SOLENOID VALVE ASSEMBLY

6 x 1.0 mm
12 N·m (1.2 kg·m, 9 lb-ft)

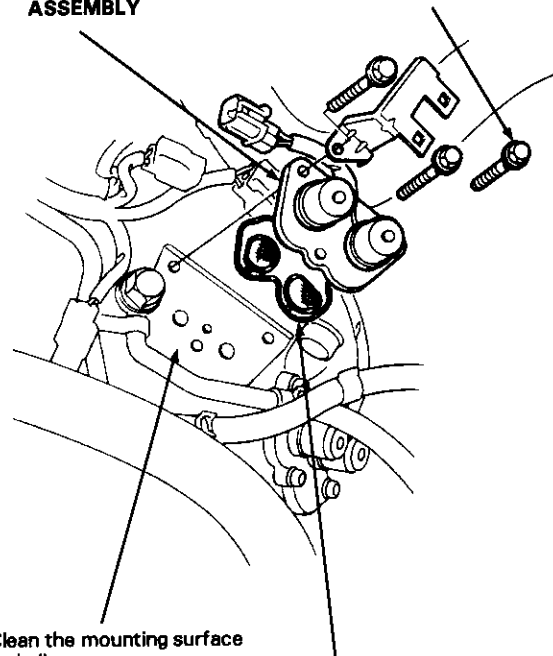

Clean the mounting surface and oil passages.

FILTER/GASKET
Replace.

3. Clean the mounting surface and oil passages of the lock-up control solenoid valve assembly, and install a new filter/gasket.
4. Check the connector for rust, dirt or oil, and reconnect it securely.

Shift Control Solenoid Valve A/B



Test

NOTE:

Shift control solenoid valves A and B must be removed/replaced as an assembly.

1. Disconnect the connector from the shift control solenoid valve A/B.
2. Measure the resistance between the No. 1 terminal (solenoid valve A) of the shift control solenoid valve connector and body ground, and between the No. 2 terminal (solenoid valve B) and body ground.

STANDARD: 12–24 Ω

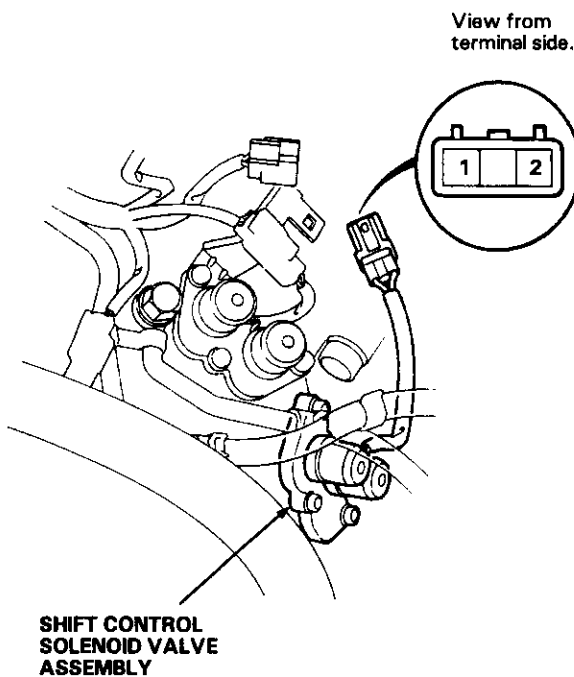

3. Replace the shift control solenoid valve assembly if the resistance is out of specification.
4. If the resistance is within the standard, connect the No. 1 terminal of the shift control solenoid valve connector to the battery positive terminal. A clicking sound should be heard. Connect the No. 2 terminal to the battery positive terminal. A clicking sound should be heard. Replace the shift control solenoid valve assembly if no clicking sound is heard.

Replacement

1. Remove the mounting bolts and shift control solenoid valve assembly.

NOTE:

Be sure to remove or replace the shift control solenoid valves A and B as an assembly.

2. Check the shift control solenoid valve oil passages for dust or dirt, and replace as an assembly, if necessary.

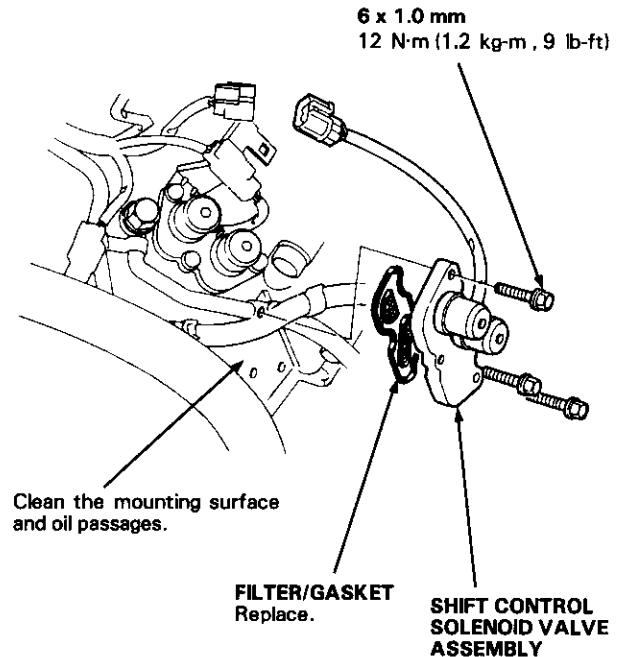

3. Clean the mounting surface and oil passages of the shift control solenoid valve assembly, and install a new filter/gasket.
4. Check the connector for rust, dirt or oil, and reconnect it securely.

Symptom-to-Component Chart

Hydraulic System

SYMPTOM	Check these items on the PROBABLE CAUSE List	Check these items on the NOTES List
Engine runs, but car does not move in any gear.	1, 6, 7, 16	K, L, R, S
Car moves in "R" and "2", but not in "D3", "D4" or "1" position.	8, 29, 44, 48	C, M, O
Car moves in "D3", "D4", "1", "R", but not in "2" position.	9, 30, 49	C, L
Car moves in "D3", "D4", "2", "1", but not in "R" position.	1, 11, 22, 34, 38, 39, 40	C, L, Q
Car moves in "N" position.	1, 8, 9, 10, 11, 46, 47	C, D
Excessive idle vibration.	5, 17	B, K, L
Slips in all gears.	6, 7, 16	C, L
No engine braking in "1" position.	12	C, D, L
Slips in 1st gear.	8, 29, 44, 48	C, N, O
Slips in 2nd gear.	9, 20, 23, 30, 49	C, L
Slips in 3rd gear.	10, 21, 23, 31, 49	C, L
Slips in 4th gear.	11, 23, 32, 44	C, L, N
Slips in reverse gear.	11, 32, 34, 44	C, N
Flares on 1-2 upshift.	3, 15, 23	E, L, V
Flares on 2-3 upshift.	3, 15, 23, 24, 49	E, L, V
Flares on 3-4 upshift.	3, 15, 23, 25, 49	E, L, N, V
No upshift; transmission stays in 1st gear.	14, 19, 23	G, L
No downshift to 1st gear.	12, 19	G, L
Late upshift.	14	L, V
Erratic shifting.	2, 14, 26	V
Harsh shift (up and down shifting).	2, 4, 15, 23, 24, 25, 26, 27, 47	A, E, H, I, L, V
Harsh shift (1-2).	2, 9, 15, 23	C, D, E, V
Harsh shift (2-3).	2, 10, 15, 23, 24	C, D, E, H, L, V
Harsh shift (3-4).	2, 11, 15, 23, 25	C, D, E, I, L, V
Harsh kick-down shifts.	2, 15, 23, 26, 27, 28	E, L, V, Q
Harsh kick-down shift (2-1).	48	O
Harsh downshift at closed throttle.	2, 15, 23	E, T
Harsh shift when manually shifting to "1" position.	33	L
Axle(s) slips out of transmission on turns.	43, 50	L, P, Q
Axle(s) stuck in transmission.	43	L, Q
Ratcheting noise when shifting into "R" position.	6, 7, 38, 39, 40	K, L, Q
Loud popping noise when taking off in "R" position.	38, 39, 40	L, Q
Ratcheting noise when shifting from "R" to "P" position or from "R" to "N" position.	38, 39, 40, 45	L, Q
Noise from transmission in all selector lever positions.	6, 17	K, L, Q
Noise from transmission only when wheels are rolling.	39, 42	L, Q
Gear whine, rpm related (pitch changes with shifts).	8, 13, 41	K, L, Q
Gear whine, speed related (pitch changes with speed).	38, 42	L, Q
Transmission will not shift into 4th gear in "D4" position.	1, 21, 28, 32	L
Lock-up clutch does not lock-up smoothly.	17, 36, 37	L
Lock-up clutch does not operate properly.	2, 3, 15, 18, 35, 36, 37	E, L, V
Transmission has multitude of problems shifting. At disassembly, large particles of metal are found on magnet.	43	L, Q



PROBABLE CAUSE

1.	Shift cable broken/out of adjustment.
2.	Throttle cable too short.
3.	Throttle cable too long.
4.	Wrong type ATF.
5.	Idle rpm too low/high.
6.	Oil pump worn or binding.
7.	Pressure regulator stuck.
8.	1st clutch defective.
9.	2nd clutch defective.
10.	3rd clutch defective.
11.	4th clutch defective.
12.	1st-hold clutch defective.
13.	Mainshaft, countershaft, and secondary shaft idler gears worn/damaged.
14.	Modulator valve stuck.
15.	Throttle valve B stuck.
16.	ATF strainer clogged.
17.	Torque converter defective.
18.	Torque converter check valve stuck.
19.	1-2 shift valve stuck.
20.	2-3 shift valve stuck.
21.	3-4 shift valve stuck.
22.	Servo control valve stuck.
23.	Clutch pressure control (CPC) valve stuck.
24.	2nd orifice control valve stuck.
25.	Orifice control valve stuck.
26.	3-2 kick-down valve stuck.
27.	3rd kick-down valve stuck.
28.	4th exhaust valve stuck.
29.	1st accumulator defective.
30.	2nd accumulator defective.
31.	3rd accumulator defective.
32.	4th accumulator defective.
33.	1st-hold accumulator defective.
34.	Servo valve stuck.
35.	Lock-up timing valve stuck.
36.	Lock-up shift valve stuck.
37.	Lock-up control valve stuck.
38.	Shift fork bent.
39.	Reverse gears worn/damaged (3 gears).
40.	Reverse selector worn.
41.	3rd gears worn/damaged (2 gears).
42.	Final gears worn/damaged (2 gears).
43.	Differential pinion shaft worn.
44.	Feedpipe O-ring broken.
45.	4th gears worn/damaged (2 gears).
46.	Gear clearance incorrect.
47.	Clutch clearance incorrect.
48.	One-way (sprag) clutch defective.
49.	Sealing rings/guide worn.
50.	Axle-inboard joint clip missing.

(cont'd)

Symptom-to-Component Chart

Hydraulic System (cont'd)

The following symptoms can be caused by improper repair or assembly.	Check these items on the PROBABLE CAUSE DUE TO IMPROPER REPAIR List	Items on the NOTES List
Car creeps in N position.	R1, R2	
Car does not move in "D3" or "D4" position.	R4	
Transmission locks up in "R" position.	R3, R12	
Excessive drag in transmission.	R6	R, K
Excessive vibration, rpm related.	R7	
Noise with wheels moving only.	R5	
Main seal pops out.	R8	S
Various shifting problems.	R9, R10	
Harsh upshifts.	R11	

PROBABLE CAUSE DUE TO IMPROPER REPAIR

R1.	Improper clutch clearance.
R2.	Improper gear clearance.
R3.	Parking brake lever installed upside down.
R4.	One-way (sprag) clutch installed upside down.
R5.	Reverse selector hub installed upside down.
R6.	Oil pump binding.
R7.	Torque converter not fully seated in oil pump.
R8.	Main seal improperly installed.
R9.	Springs improperly installed.
R10.	Valves improperly installed.
R11.	Ball check valves not installed.
R12.	Shift fork bolt not installed.



NOTES	
A.	See flushing procedure, page 14-142 and 143.
B.	Set idle rpm in gear to specified idle speed. If still no good, adjust motor mounts as outlined in engine section of service manual.
C.	If the large clutch piston O-ring is broken, inspect the piston groove for rough machining.
D.	If the clutch pack is seized or is excessively worn, inspect the other clutches for wear, and check the orifice control valves and throttle valves for free movement.
E.	If throttle valve B is stuck, inspect the clutches for wear.
G.	If the 1 – 2 shift valve is stuck closed, the transmission will not upshift. If stuck open, the transmission has no 1st gear.
H.	If the 2nd orifice control valve is stuck, inspect the 2nd and 3rd clutch packs for wear.
I.	If the orifice control valve is stuck, inspect the 3rd and 4th clutch packs for wear.
J.	If the clutch pressure control valve is stuck closed, the transmission will not shift out of 1st gear.
K.	Improper alignment or main valve body and torque converter housing may cause oil pump seizure. The symptoms are mostly an rpm-related ticking noise or a high-pitched squeak.
L.	If the ATF strainer is clogged with particles of steel or aluminum, inspect the oil pump and differential pinion shaft. If both are OK and no cause for the contamination is found, replace the torque converter.
M.	If the 1st clutch feedpipe guide in the right side cover is scored by the secondary shaft, inspect the ball bearing for excessive movement in the transmission housing. If OK, replace the right side cover as it is dented. The O-ring under the guide is probably worn.
N.	<ul style="list-style-type: none">• Replace the mainshaft if the bushing for the 4th feedpipe is loose or damaged.• If the 4th feedpipe is damaged or out of round, replace it.• Replace the countershaft if the bushing for the 1st-hold feedpipe is loose or damaged.• If the 1st-hold feedpipe is damaged or out of round, replace it.• Replace the secondary shaft if the bushing for the 1st feedpipe is loose or damaged.• If the 1st feedpipe is damaged or out of round, replace it.
O.	A worn or damaged sprag clutch is mostly a result of shifting the transmission in "D3" or "D4" position while the wheels rotate in reverse, such as rocking the car in snow.
P.	Inspect the frame for collision damage.
Q.	Inspect for damage or wear: <ol style="list-style-type: none">1. Reverse selector gear teeth chamfers.2. Engagement teeth chamfers of countershaft 4th and reverse gear.3. Shift fork for scuff marks in center.4. Differential pinion shaft for wear under pinion gears.5. Bottom of 1st-hold clutch for swirl marks. Replace items 1, 2, 3 and 4 if worn or damaged. If transmission makes clicking, grinding or whirring noise, also replace mainshaft 4th gear and reverse idler gear and countershaft 4th gear in addition to 1, 2, 3 or 4. If differential pinion shaft is worn, overhaul differential assembly, and replace ATF strainer, and thoroughly clean transmission, flush torque converter, cooler and lines. If bottom of 1st-hold clutch is swirled and transmission makes gear noise, replace the countershaft and final driven gear.
R.	Be very careful not to damage the torque converter housing when replacing the main ball bearing. You may also damage the oil pump when you torque down the main valve body. This will result in oil pump seizure if not detected. Use proper tools.
S.	Install the main seal flush with the torque converter housing. If you push it into the torque converter housing until it bottoms out, it will block the oil return passage and result in damage.
T.	Harsh downshifts when coasting to a stop with zero throttle may be caused by a bent-in throttle valve retainer/cam stopper. Throttle cable adjustment may clear this problem.
U.	Check if servo valve stopper cap is installed. If it was not installed, the check valve may have been pushed out by hydraulic pressure causing a leak (internal) affecting all forward gears.
V.	Throttle cable adjustment is essential for proper operation of the transmission. Not only does it affect the shift points if misadjusted, but also the shift quality and lock-up clutch operation. A cable adjusted too long will result in throttle pressure being too low for the amount of engine torque input into the transmission and may cause clutch slippage. A cable adjusted too short will result in too high throttle pressure which may cause harsh shifts, erratic shifts and torque converter hunting.

Road Test

NOTE:

Warm up the engine to normal operating temperature (the radiator fan comes on).

1. Apply parking brake and block the wheels. Start the engine, then move the selector lever to **D4** position while depressing the brake pedal. Depress the accelerator pedal and release it suddenly. Engine should not stall.
2. Repeat same test in **D3** position.
3. Shift the selector lever to **D4** position and check that the shift points occur at approximate speeds shown. Also check for abnormal noise and clutch slippage.

NOTE:

Throttle position sensor voltage represents the throttle opening.

- 1. Connect the Test Harness between the ECM and connector (see section 11).
- 2. Set the digital multimeter to check voltage between D11 (+) terminal and D22 (-) terminal for the throttle position sensor.

CAUTION:

- All SRS electrical wiring harnesses are covered with yellow outer insulation.
- Before disconnecting the SRS wire harness, install the short connector(s) on the airbag(s).
- Replace the entire affected SRS harness assembly if it has an open circuit or damaged wiring.

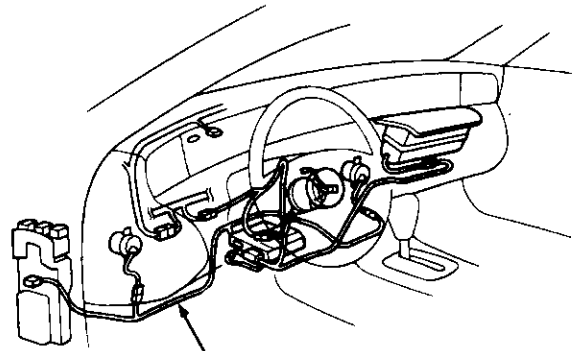

SRS MAIN HARNESS

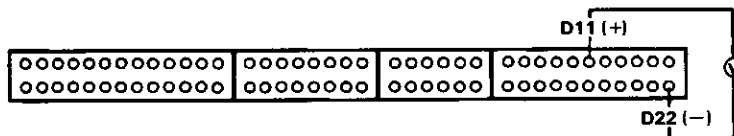
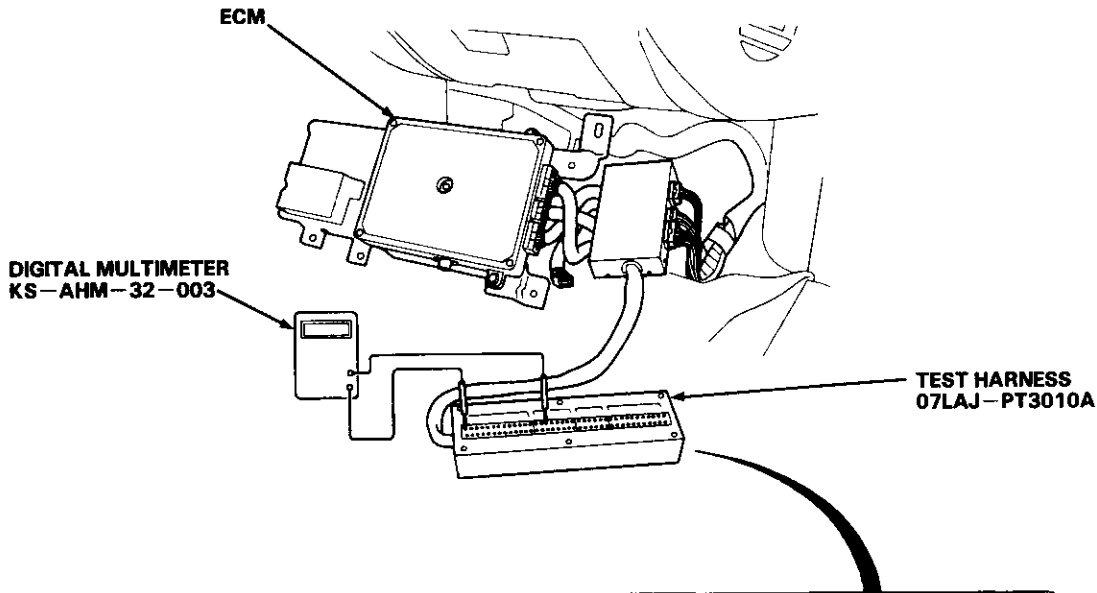



F22A1 Engine: **D4** Position

· Upshift

		1st→2nd	2nd→3rd	3rd→4th	Lock-up Clutch ON
Throttle position sensor voltage: 0.83V Coasting down-hill from a stop	mph	13-15	26-28	36-40	14-17
	km/h	21-24	42-45	58-64	23-27
Throttle position sensor voltage: 2.18V Acceleration from a stop	mph	17-21	37-41	57-63	61-67
	km/h	27-34	60-66	92-101	98-108
Full-throttle Acceleration from a stop	mph	29-34	60-65	88-94	81-86
	km/h	47-55	97-105	142-151	130-138

· Downshift

		Lock-up Clutch OFF	4th→3rd	3rd→2nd	2nd→1st
Throttle position sensor voltage: 0.83V Coasting or braking to a stop	mph	13-16	————	18-22 (4th→2nd)	6-10
	km/h	21-26	————	29-35 (4th→2nd)	10-16
Throttle position sensor voltage: 2.18V When car is slowed by increased grade, wind, etc.	mph	53-59	————	————	————
	km/h	85-95	————	————	————
Full-throttle When car is slowed by increased grade, wind, etc.	mph	77-82	76-82	52-57	21-26
	km/h	124-132	123-132	84-92	34-42

(cont'd)

Road Test

(cont'd)

H23A1 Engine: **D4** Position

Upshift		1st→2nd	2nd→3rd	3rd→4th	Lock-up Clutch ON
Throttle position sensor voltage: 0.83V Coasting down-hill from a stop	mph	13–15	26–28	36–40	14–17
	km/h	21–24	42–45	58–64	23–27
Throttle position sensor voltage: 2.18V Acceleration from a stop	mph	18–22	36–40	54–60	58–64
	km/h	29–35	58–64	87–97	93–103
Full-throttle Acceleration from a stop	mph	29–34	57–62	83–88	80–85
	km/h	47–55	92–100	134–142	129–137

Downshift		Lock-up Clutch OFF	4th→3rd	3rd→2nd	2nd→1st
Throttle position sensor voltage: 0.83V Coasting or braking to a stop	mph	13–16	————	18–22 (4th→2nd)	6–10
	km/h	21–26	————	29–35 (4th→2nd)	10–16
Throttle position sensor voltage: 2.18V When car is slowed by increased grade, wind, etc.	mph	48–54	————	————	————
	km/h	77–87	————	————	————
Full-throttle When car is slowed by increased grade, wind, etc.	mph	73–80	73–79	51–56	24–29
	km/h	117–129	117–127	82–90	39–47

4. Accelerate to about 35 mph (57 km/h) so the transmission is in 4th, then shift **D4** position to **2** position. The car should immediately begin slowing down from engine braking.

CAUTION:

Do not shift from **D4** or **D3** position to **2** or **1** position at speeds over 63 mph (100 km/h); you may damage the transmission.

5. Check for abnormal noise and clutch slippage in the following positions.

1 (1st Gear) Position

- 1. Accelerate from a stop at full throttle. Check that there is no abnormal noise or clutch slippage.
- 2. Upshifts should not occur with the selector in this position.

2 (2nd Gear) Position

- 1. Accelerate from a stop at full throttle. Check that there is no abnormal noise or clutch slippage.
- 2. Upshifts and downshifts should not occur with the selector in this position.

R (Reverse) Position

Accelerate from a stop at full throttle, and check for abnormal noise and clutch slippage.

6. Test in **P** (Parking) Position

Park car on slope (approx. 16°), apply the parking brake, and shift into **P** position. Release the brake; the car should not move.



Stall Speed

Test

CAUTION:

- To prevent transmission damage, do not test stall speed for more than 10 seconds at a time.
- Do not shift the lever while raising the engine speed.
- Be sure to remove the pressure gauge before testing stall speed.

1. Engage parking brake and block the front wheels.
2. Connect tachometer, and start the engine.
3. Make sure the A/C switch is OFF.
4. After the engine has warmed up to normal operating temperature (the radiator fan comes on), shift into **2** position.
5. Fully depress the brake pedal and accelerator for 6 to 8 seconds, and note engine speed.
6. Allow 2 minutes for cooling, then repeat the test in **D4**, **1**, and **R** positions.

NOTE:

- Stall speed tests should be used for diagnostic purposes only.
- Stall speed should be the same in **D4**, **2**, **1** and **R** positions.

Stall Speed RPM:

F22A1 Engine

Specification: 2,500 rpm
Service Limit: 2,350–2,650 rpm

H23A1 Engine

Specification: 2,750 rpm
Service Limit: 2,600–2,900 rpm

TROUBLE	PROBABLE CAUSE
Stall rpm high in D4 , 2 , 1 and R positions	<ul style="list-style-type: none"> • Low fluid level or oil pump output • Clogged ATF strainer • Pressure regulator valve stuck closed • Slipping clutch
Stall rpm high in R position	<ul style="list-style-type: none"> • Slippage of 4th clutch
Stall rpm high in 2 and D4 positions	<ul style="list-style-type: none"> • Slippage of 2nd clutch
Stall rpm high in 1 position	<ul style="list-style-type: none"> • Slippage of 1st clutch or 1st gear one-way clutch
Stall rpm low in D4 , 2 , 1 and R positions	<ul style="list-style-type: none"> • Engine output low • Torque converter one-way clutch slipping

Fluid Level

Checking/Changing

Checking

NOTE:

Check the fluid level with the engine at normal operating temperature (the radiator fan comes on).

1. Park the car on level ground. Turn off the engine.
2. Remove the dipstick (yellow loop) from the transmission, and wipe it with a clean cloth.
3. Insert the dipstick into the transmission.

DIPSTICK (YELLOW LOOP)

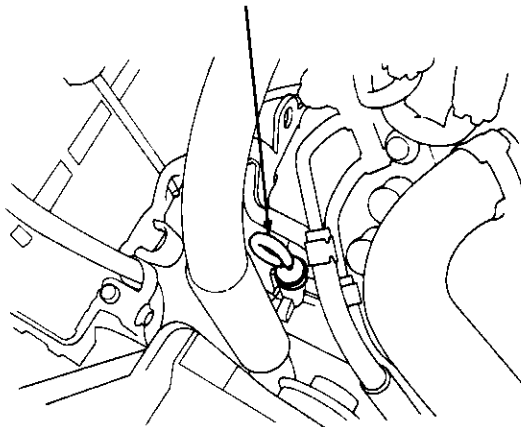

4. Remove the dipstick and check the fluid level. It should be between the upper and lower marks.

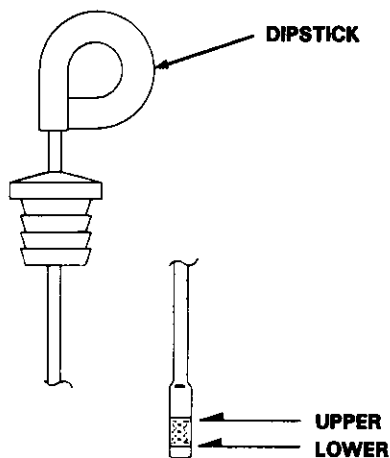

5. If the level is below the lower mark, add fluid into the tube to bring it to the upper mark. Use Honda Premium Formula Automatic Transmission Fluid or an equivalent DEXRON® II Automatic Transmission Fluid (ATF) only.
6. Insert the dipstick back into the transmission.

Changing

1. Bring the transmission up to normal operating temperature (the radiator fan comes on) by driving the car. Park the car on level ground, turn the engine off, and then remove the drain plug.

NOTE:

If a cooler flusher is to be used, see page 14-142 and 143.

2. Reinstall the drain plug with a new sealing washer; then refill the transmission to the upper mark on the dipstick.

Automatic Transmission Fluid Capacity:

2.4 ℓ (2.5 US qt, 2.1 Imp qt) at changing
6.0 ℓ (6.3 US qt, 5.3 Imp qt) at overhaul

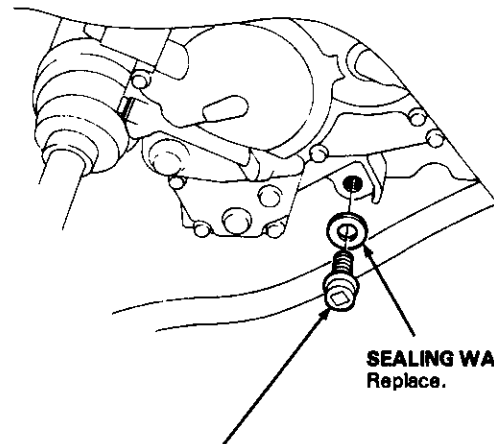

DRAIN PLUG
18 x 1.5 mm
50 N·m (5.0 kg·m, 36 lb-ft)



Pressure Testing

▲ WARNING

- While testing, be careful of the rotating front wheels.
- Make sure lifts, jacks, and safety stands are placed properly (see section 1).

CAUTION:

- Before testing, be sure the transmission fluid is filled to the proper level.
- Warm up the engine before testing.

1. Raise the car. (see section 1).
2. Warm up the engine, then stop the engine and connect a tachometer.
3. Connect the oil pressure gauge to each inspection hole.

TORQUE: 18 N·m (1.8 kg-m, 13 lb-ft)

CAUTION:

Connect the oil pressure gauge securely; be sure not to allow dust and other foreign particles to enter the inspection hole.

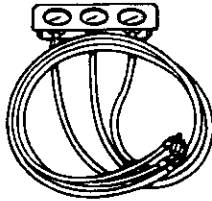

**A/T OIL PRESSURE
GAUGE SET
07406-0020003**

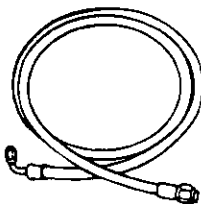

**A/T OIL PRESSURE
HOSE
07406-0020201**

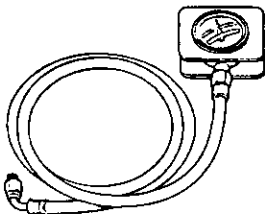

**A/T LOW PRESSURE
GAUGE
07406-0070000**

4. Start the engine, and measure the respective pressure as follows:
 - Line Pressure
 - Throttle B Pressure
 - Clutch Pressure
 - Clutch Low/High Pressure

5. Install a new washer and the sealing bolt in the inspection hole, and tighten to the specified torque.

TORQUE: 18 N·m (1.8 kg-m, 13 lb-ft)

NOTE:

Do not reuse old aluminum washers.

(cont'd)

Pressure Testing

(cont'd)

• Line Pressure Measurement

- 1. Set the parking brake and block both rear wheels securely.
- 2. Run the engine at 2,000 rpm.
- 3. Shift the select lever to **N** or **P** position.

NOTE:

Higher pressures may be indicated if measurements are made in selector positions other than **N** or **P** position.

- 4. Measure line pressure.

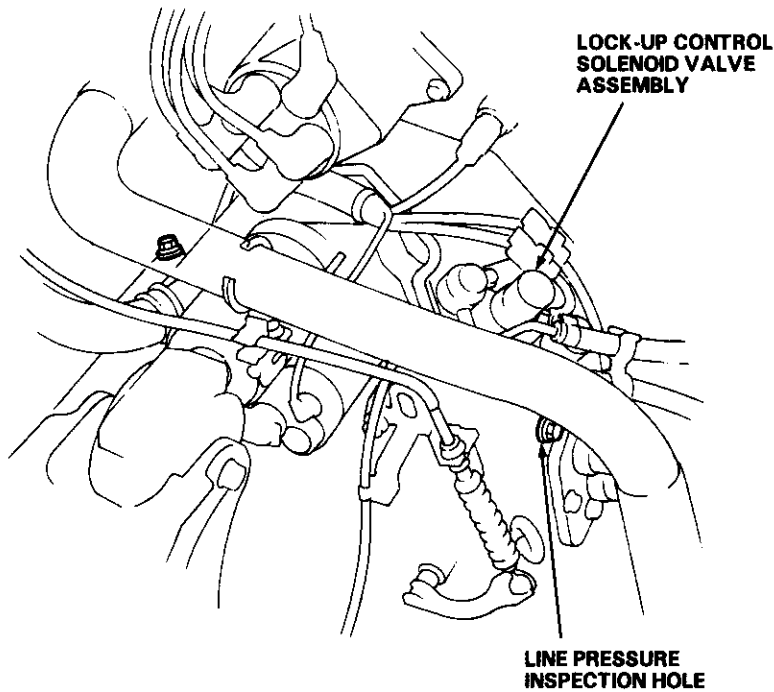

F22A1 Engine

PRESSURE	SELECTOR POSITION	SYMPTOM	PROBABLE CAUSE	FLUID PRESSURE	
				Standard	Service Limit
Line	N or P	No (or low) line pressure	Torque converter, oil pump, pressure regulator, torque converter check valve	800—850 kPa (8.0—8.5 kg/cm ² , 114—121 psi)	750 kPa (7.5 kg/cm ² , 107 psi)

H23A1 Engine

PRESSURE	SELECTOR POSITION	SYMPTOM	PROBABLE CAUSE	FLUID PRESSURE	
				Standard	Service Limit
Line	N or P	No (or low) line pressure	Torque converter, oil pump, pressure regulator, torque converter check valve	850—900 kPa (8.5—9.0 kg/cm ² , 121—128 psi)	800 kPa (8.0 kg/cm ² , 114 psi)



• **Throttle B Pressure Measurement**

- 1. Set the parking brake securely and block the wheels.
- 2. Run the engine at 1,000 rpm.
- 3. Disconnect the throttle control cable from the throttle control lever and set the throttle control lever in full throttle position.

**THROTTLE B PRESSURE
INSPECTION HOLE**

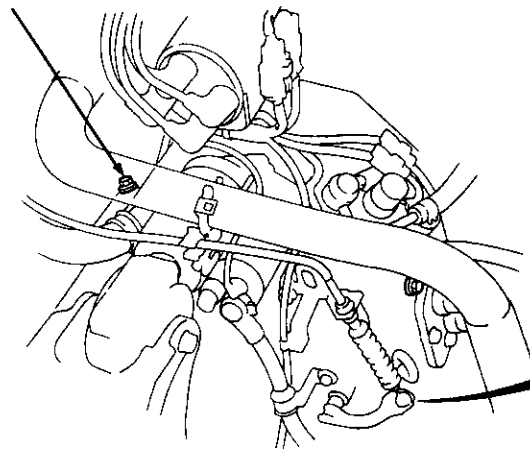

**THROTTLE CONTROL
CABLE**

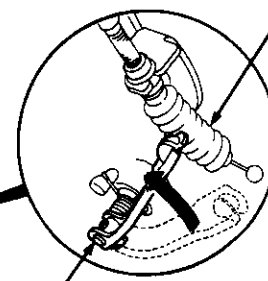

**THROTTLE CONTROL
LEVER**

F22A1 Engine

PRESSURE	SELECTOR POSITION	SYMPTOM	PROBABLE CAUSE	FLUID PRESSURE	
				Standard	Service Limit
Throttle B	D4	Pressure too high	Throttle Valve B	0 kPa (0 kg/cm ² , 0.0 psi) throttle lever fully-closed	_____
		No or low pressure		800 — 850 kPa (8.0—8.5 kg/cm ² , 114—121 psi) throttle lever fully-opened	750 kPa (7.5 kg/cm ² , 107 psi) throttle lever fully-opened

H23A1 Engine

PRESSURE	SELECTOR POSITION	SYMPTOM	PROBABLE CAUSE	FLUID PRESSURE	
				Standard	Service Limit
Throttle B	D4	Pressure too high	Throttle Valve B	0 kPa (0 kg/cm ² , 0.0 psi) throttle lever fully-closed	_____
		No or low pressure		850 — 900 kPa (8.5—9.0 kg/cm ² , 121—128 psi) throttle lever fully-opened	800 kPa (8.0 kg/cm ² , 114 psi) throttle lever fully-opened

(cont'd)

Pressure Testing

(cont'd)

• Clutch Pressure Measurement

▲ WARNING

While testing, be careful of the rotating front wheels.

- 1. Set the parking brake and block both rear wheels securely.
- 2. Raise the front of the car and support it with safety stands.
- 3. Allow the front wheels to rotate freely.
- 4. Run the engine at 2,000 rpm.
- 5. Measure each clutch pressure.

1ST CLUTCH PRESSURE
INSPECTION HOLE

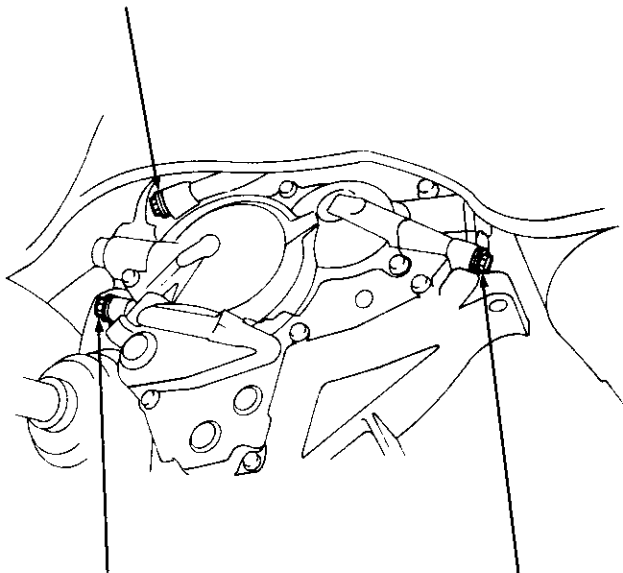

1ST-HOLD CLUTCH PRESSURE
INSPECTION HOLE

4TH CLUTCH PRESSURE
INSPECTION HOLE

2ND CLUTCH PRESSURE
INSPECTION HOLE

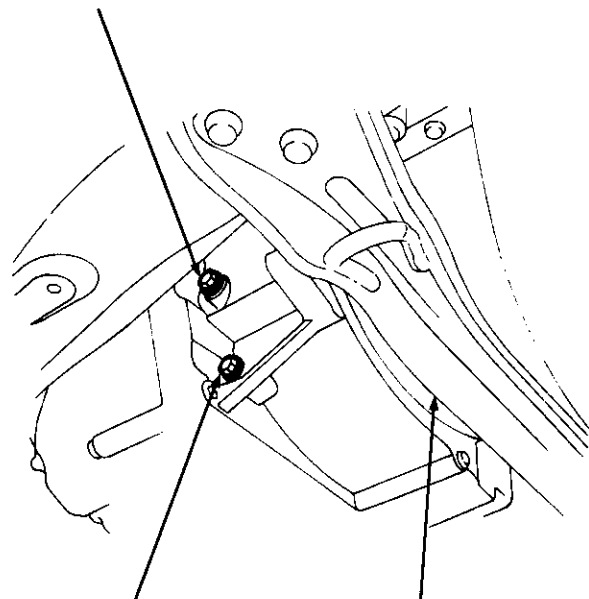

3RD CLUTCH PRESSURE
INSPECTION HOLE

CENTER BEAM



F22A1 Engine

PRESSURE	SELECTOR POSITION	SYMPTOM	PROBABLE CAUSE	FLUID PRESSURE	
				Standard	Service Limit
1st Clutch	1 or D4	No or low 1st pressure	1st Clutch	800 — 850 kPa (8.0—8.5 kg/cm ² , 114—121 psi)	750 kPa (7.5 kg/cm ² , 107 psi)
1st-hold Clutch	1	No or low 1st-hold pressure	1st-hold Clutch		
2nd Clutch	2	No or low 2nd pressure	2nd Clutch		
2nd Clutch	D4	No or low 2nd pressure	2nd Clutch	500 kPa (5.0 kg/cm ² , 71 psi) (Throttle lever fully closed) 850 kPa (8.5 kg/cm ² , 121 psi) (Throttle lever more than 3/16 opened)	450 kPa (4.5 kg/cm ² , 64 psi) (Throttle lever fully closed) 750 kPa (7.5 kg/cm ² , 107 psi) (Throttle lever more than 3/16 opened)
3rd Clutch		No or low 3rd pressure	3rd Clutch		
4th Clutch		No or low 4th pressure	4th Clutch		
	R		Servo Valve or 4th Clutch	800—850 kPa (8.0—8.5 kg/cm ² , 114—121 psi)	750 kPa (7.5 kg/cm ² , 107 psi)

H23A1 Engine

PRESSURE	SELECTOR POSITION	SYMPTOM	PROBABLE CAUSE	FLUID PRESSURE	
				Standard	Service Limit
1st Clutch	1 or D4	No or low 1st pressure	1st Clutch	850 — 900 kPa (8.5—9.0 kg/cm ² , 121—128 psi)	800 kPa (8.0 kg/cm ² , 114 psi)
1st-hold Clutch	1	No or low 1st-hold pressure	1st-hold Clutch		
2nd Clutch	2	No or low 2nd pressure	2nd Clutch		
2nd Clutch	D4	No or low 2nd pressure	2nd Clutch	500 kPa (5.0 kg/cm ² , 71 psi) (Throttle lever fully closed) 900 kPa (9.0 kg/cm ² , 128 psi) (Throttle lever more than 3/16 opened)	450 kPa (4.5 kg/cm ² , 64 psi) (Throttle lever fully closed) 800 kPa (8.0 kg/cm ² , 114 psi) (Throttle lever more than 3/16 opened)
3rd Clutch		No or low 3rd pressure	3rd Clutch		
4th Clutch		No or low 4th pressure	4th Clutch		
	R		Servo Valve or 4th Clutch	850—900 kPa (8.5—9.0 kg/cm ² , 121—128 psi)	800 kPa (8.0 kg/cm ² , 114 psi)

(cont'd)

Pressure Testing

(cont'd)

• Low/High Pressure Test

- 1. Set the parking brake and block the rear wheels securely.
- 2. Raise the car and support with safety stands.
- 3. Attach the gauge set to the appropriate pressure inspection holes.
- 4. Remove the throttle control cable end of the throttle control lever.

NOTE:

Do not loosen the locknuts; simply unhook the throttle control cable end.

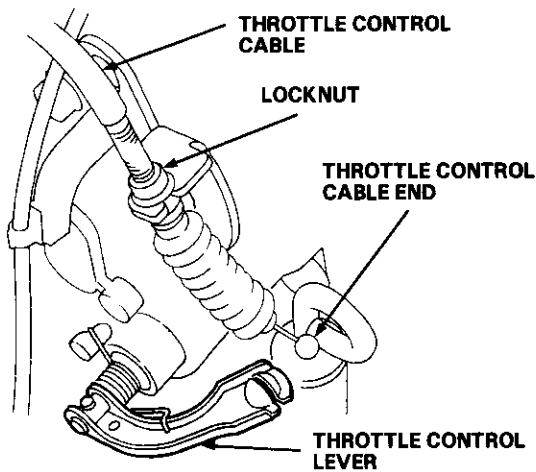

- 5. Warm up the engine to normal operating temperature (the radiator fan comes on).
- 6. With the engine idling, move the selector lever to **D4** position.
- 7. Slowly move the throttle linkage to increase engine rpm until pressure is indicated on the appropriate gauge. Then release the throttle linkage, allowing the engine to return to an idle, and record the pressure reading.

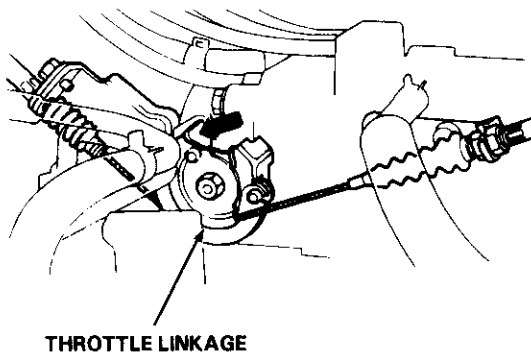

- 8. With the engine idling, lift the throttle control lever up approximately 1/2 of its possible travel and increase the engine rpm until pressure is indicated on the appropriate gauge. Record the highest pressure reading obtained.

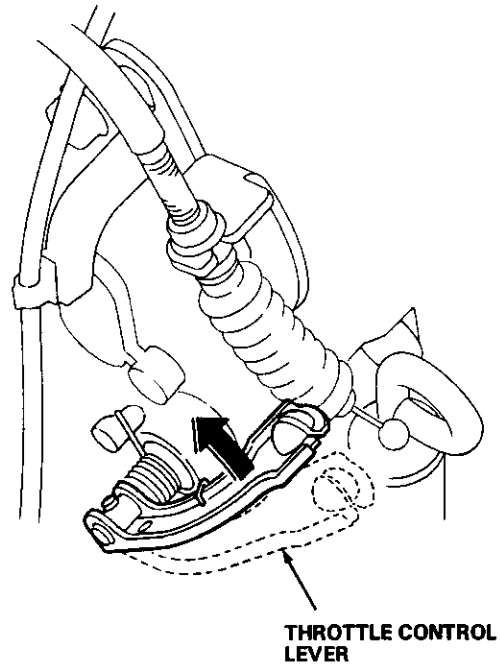

- 9. Repeat steps -7. and -8. for each clutch pressure being inspected.

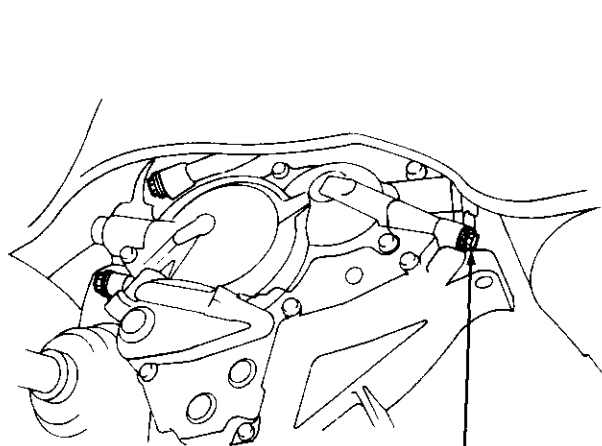

4TH CLUTCH PRESSURE INSPECTION HOLE

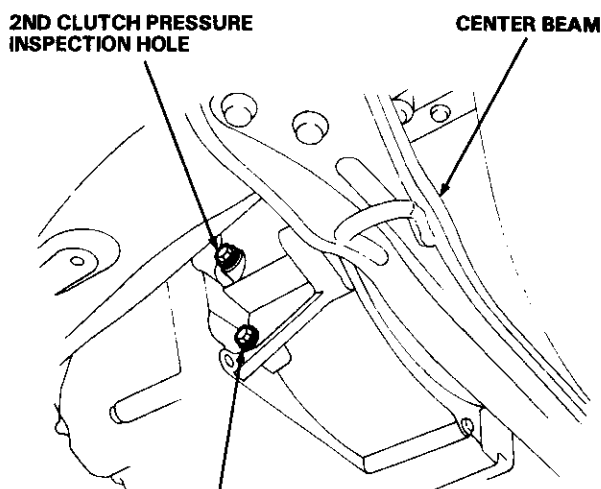

2ND CLUTCH PRESSURE INSPECTION HOLE

CENTER BEAM

3RD CLUTCH PRESSURE INSPECTION HOLE

F22A1 Engine

PRESSURE	SELECTOR POSITION	SYMPTOM	PROBABLE CAUSE	FLUID PRESSURE	
				Standard	Service Limit
2nd Clutch	D4	No or low 2nd pressure	2nd Clutch	500 — 850 kPa (5.0—8.5 kg/cm ² , 71—121 psi) varies with throttle lever opening	450 kPa (4.5 kg/cm ² , 64 psi) (Throttle lever fully closed) 750 kPa (7.5 kg/cm ² , 107 psi) (Throttle lever more than 3/16 opened)
3rd Clutch		No or low 3rd pressure	3rd Clutch		
4th Clutch		No or low 4th pressure	4th Clutch		

H23A1 Engine

PRESSURE	SELECTOR POSITION	SYMPTOM	PROBABLE CAUSE	FLUID PRESSURE	
				Standard	Service Limit
2nd Clutch	D4	No or low 2nd pressure	2nd Clutch	500 — 900 kPa (5.0—9.0 kg/cm ² , 71—128 psi) varies with throttle lever opening	450 kPa (4.5 kg/cm ² , 64 psi) (Throttle lever fully closed) 800 kPa (8.0 kg/cm ² , 114 psi) (Throttle lever more than 3/16 opened)
3rd Clutch		No or low 3rd pressure	3rd Clutch		
4th Clutch		No or low 4th pressure	4th Clutch		

Transmission

Removal

▲ WARNING

- Make sure lifts, jacks and safety stands are placed properly, and hoist brackets are attached to the correct position on the engine (see section 1).
- Apply parking brake and block rear wheels, so car will not roll off stands and fall on you while working under it.

CAUTION:

Use fender covers to avoid damaging painted surfaces.

CAUTION:

- All SRS electrical wiring harnesses are covered with yellow outer insulation.
- Before disconnecting the SRS wire harness, install the short connector (s) on the airbag (s).
- Replace the entire affected SRS harness assembly if it has an open circuit or damaged wiring.

NOTE:

The radio may have a coded theft protection circuit. Be sure to get the customer's code number before.

- Disconnecting the battery.
- Removing the No. 43 (10 A) fuse.
(In the under-hood fuse/relay box)
- Removing the radio.

After service, reconnect power to the radio and turn it on.

When the word "CODE" is displayed, enter the customer's 5-digit code to restore radio operation.

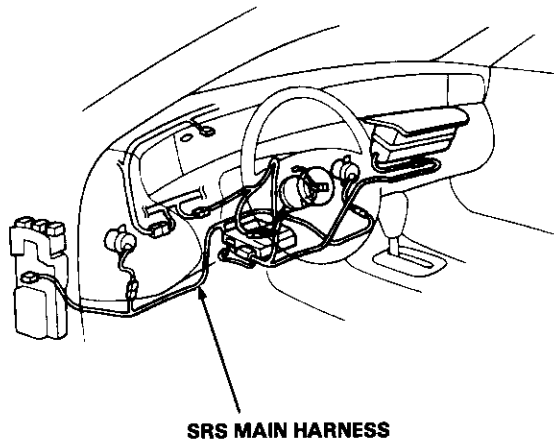

1. Disconnect the battery negative (-) and positive (+) cables from the battery.
2. Remove the battery set plate, then remove the battery.
3. Remove the drain plug, and drain the automatic transmission fluid (ATF). Reinstall the drain plug with a new sealing washer.

TORQUE: 50 N·m (5.0 kg-m, 36 lb-ft)

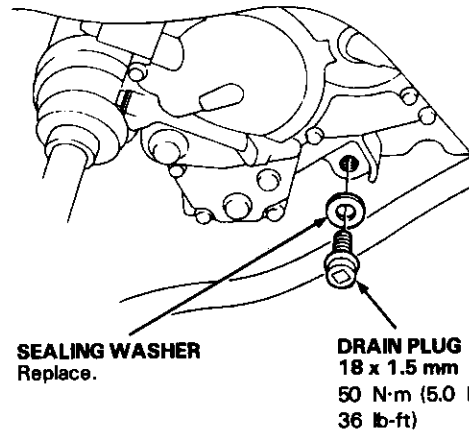

4. Remove the resonator, intake air duct and air cleaner housing.
5. Disconnect the connector from the intake control vacuum tank, then remove the intake control vacuum tank and tank bracket.

NOTE:

Do not remove the vacuum tube from the intake control vacuum tank.

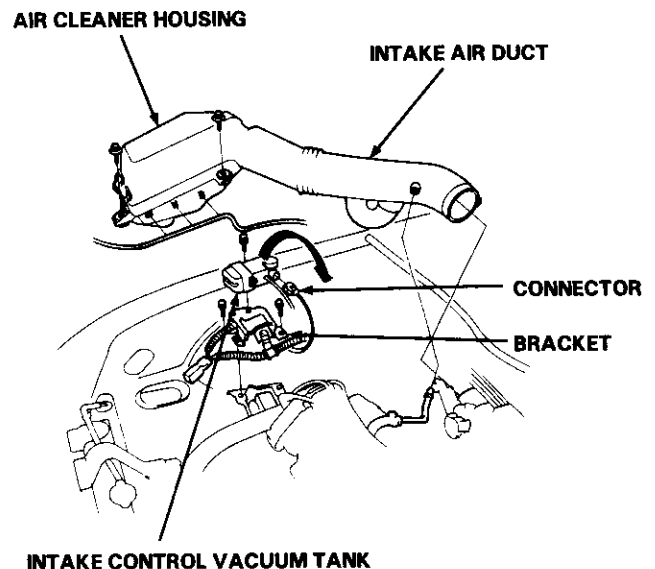



6. Disconnect the ground cable from the transmission and body.
7. Remove the battery base with the ground cable.
8. Remove the battery base stay.

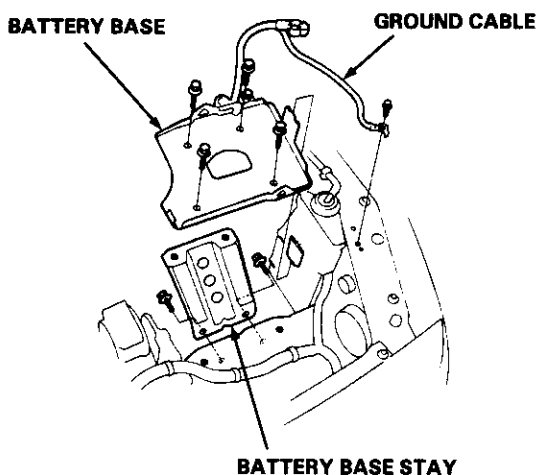

9. Disconnect the lock-up control solenoid valve and shift control solenoid valve connectors.
10. Disconnect the throttle control cable from the throttle control lever.
11. Disconnect the mainshaft speed sensor connector.
12. Remove the ATF cooler hoses at the joint pipes. Turn the ends of the ATF cooler hoses up to prevent ATF from flowing out, then plug the joint pipes.

NOTE:

Check for any signs of leakage at the hose joints.

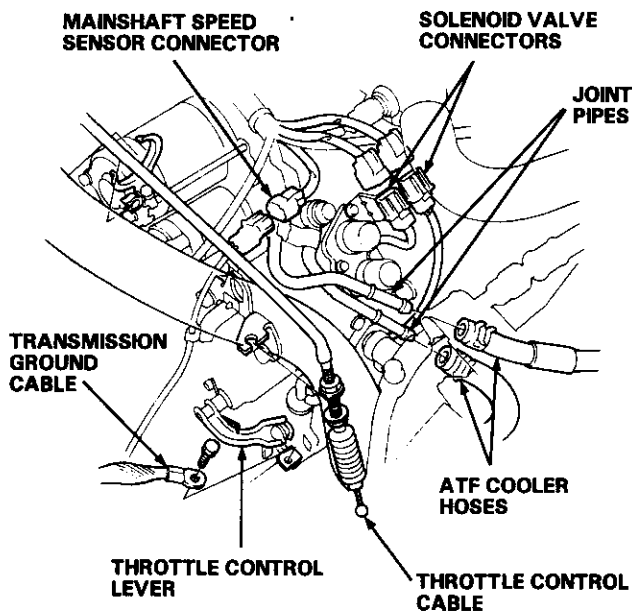

13. Remove the starter motor cables.
14. Disconnect the countershaft speed sensor connector.

COUNTERSHAFT SPEED SENSOR CONNECTOR

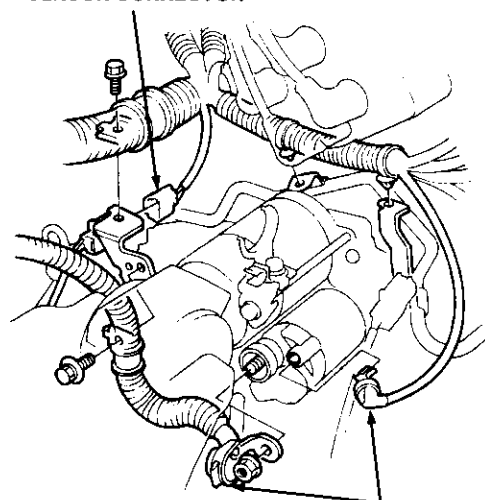

15. Disconnect the vehicle speed sensor connector. Remove the rear stiffener, then remove the vehicle speed sensor/power steering speed sensor.

NOTE:

Do not disconnect the power steering pressure hoses from the vehicle speed sensor/power steering speed sensor.

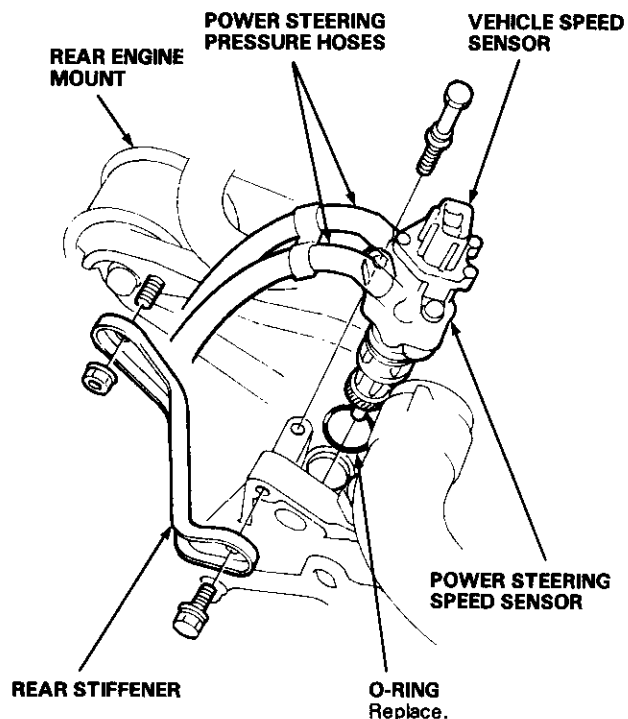

(cont'd)

Transmission Removal (cont'd)

16. Remove the transmission housing mounting bolts.

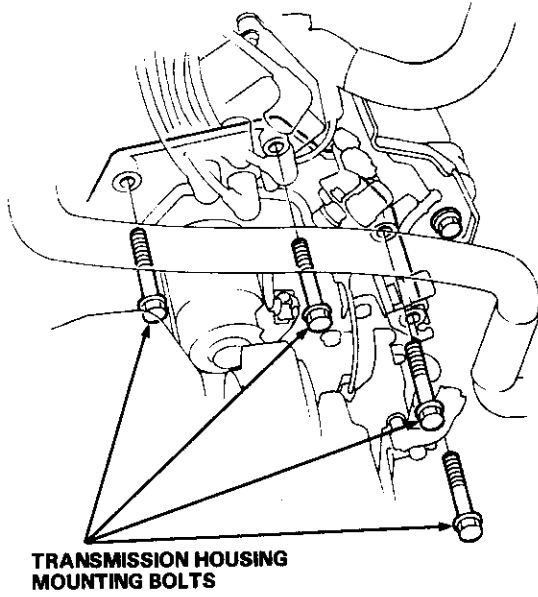

18. Remove the transmission mount.

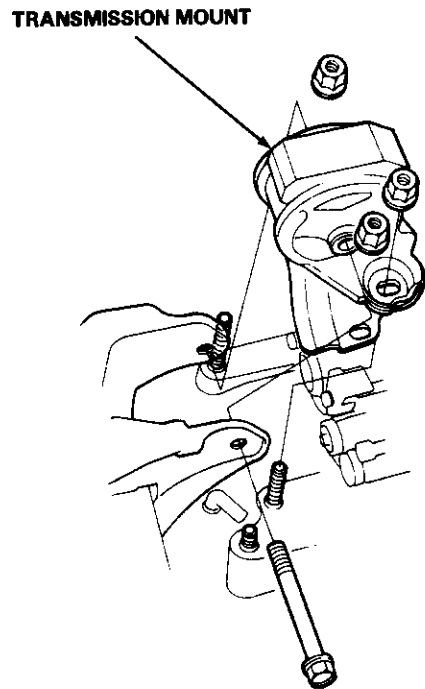

17. Loosen the front engine mount bracket bolts.

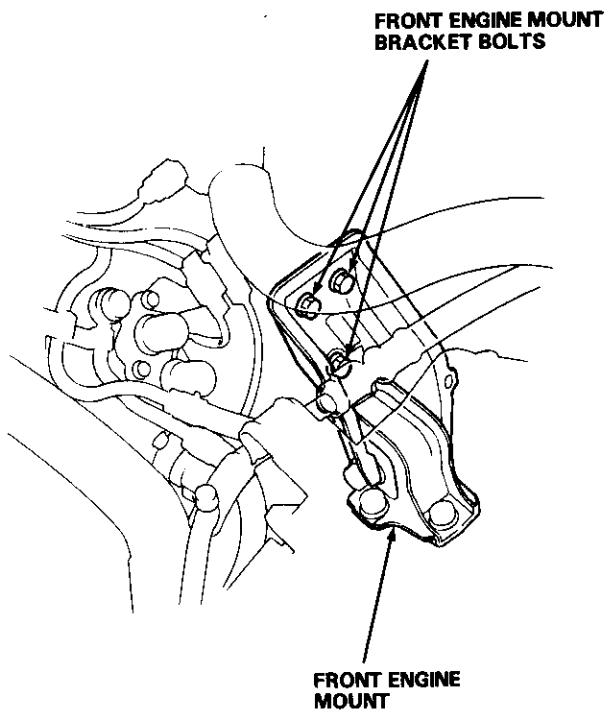

19. Remove the splash shield.

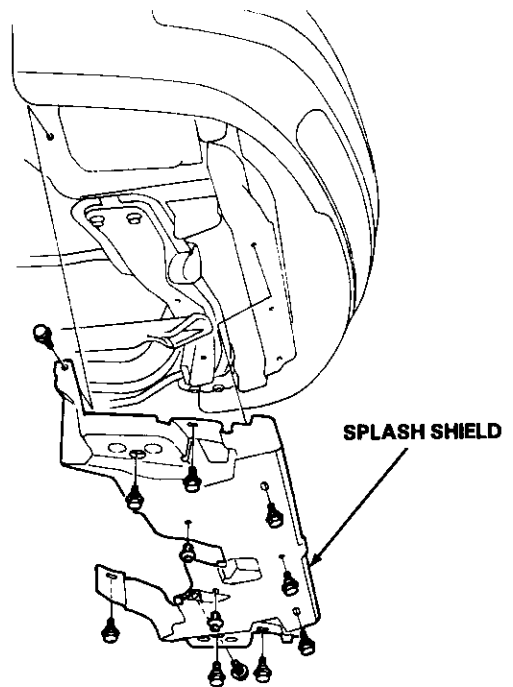



20. Remove the center beam and rear beam stiffener.

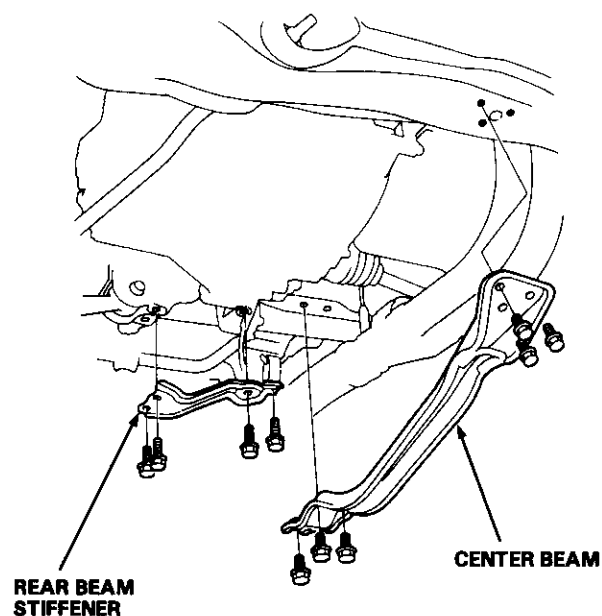

21. Remove the cotter pins and castle nuts, then separate the ball joints from the lower arm (see section 18).
22. Remove the damper fork bolts, then separate the damper fork and lower arm.

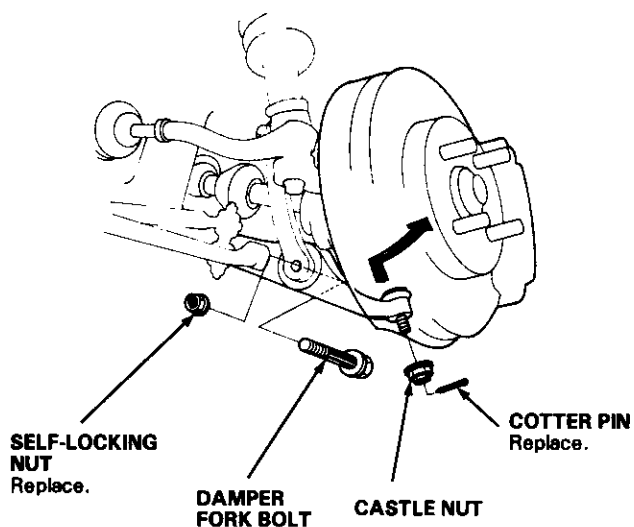

23. Pry the driveshafts out of the differential.
24. Pull on the inboard joint and remove the right and left driveshafts (see section 16).
25. Tie plastic bags over the driveshaft ends.

NOTE:

Coat all precision finished surfaces with clean engine oil or grease.

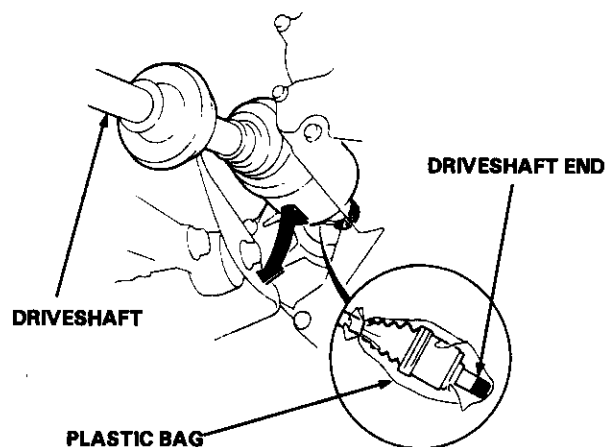

26. Remove the right damper pinch bolt, then separate the damper fork and damper.
27. Remove the self-locking bolts and self-locking nut, then remove the right radius rod.

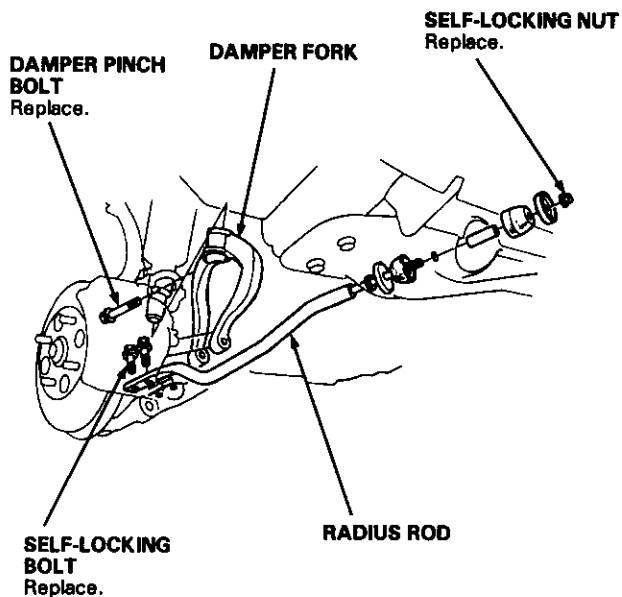

(cont'd)

Transmission

Removal (cont'd)

28. Remove the torque converter cover and shift cable cover.
29. Remove the lock bolt securing the control lever, then remove the shift cable with the control lever.

CAUTION:

Take care not to bend the shift cable while removing it.

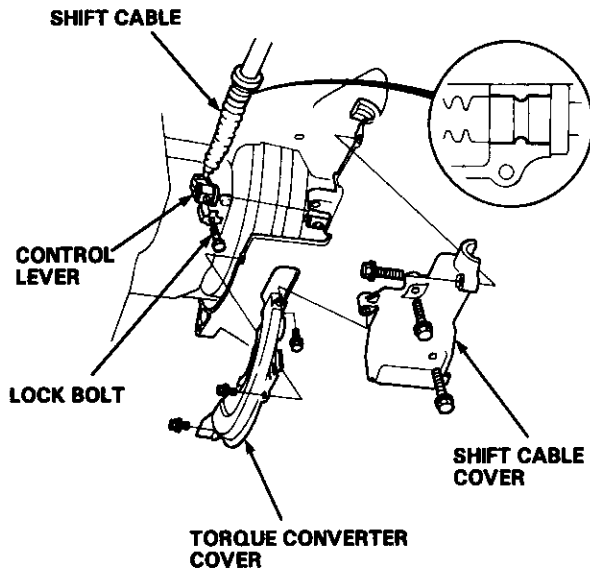

30. Remove the eight drive plate bolts one at a time while rotating the crankshaft pulley.

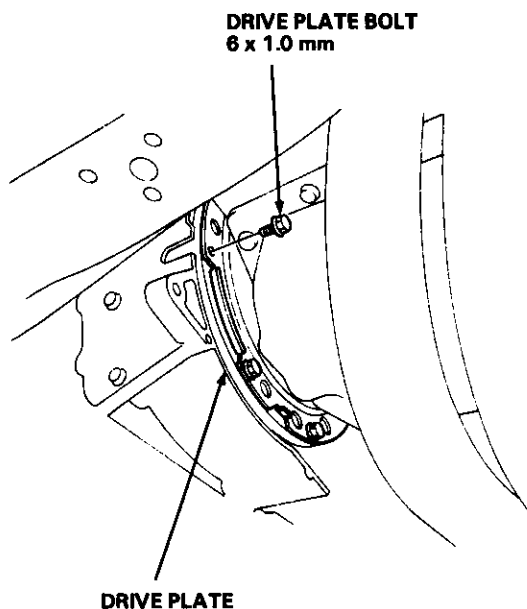

31. Place a jack under the transmission, and raise the transmission just enough to take weight off of the mount.
32. Remove the intake manifold bracket.
33. Remove the transmission housing mounting bolts and rear engine mounting bolts.
34. Pull the transmission away from the engine until it clears the 14 mm dowel pins, then lower it on the transmission jack.

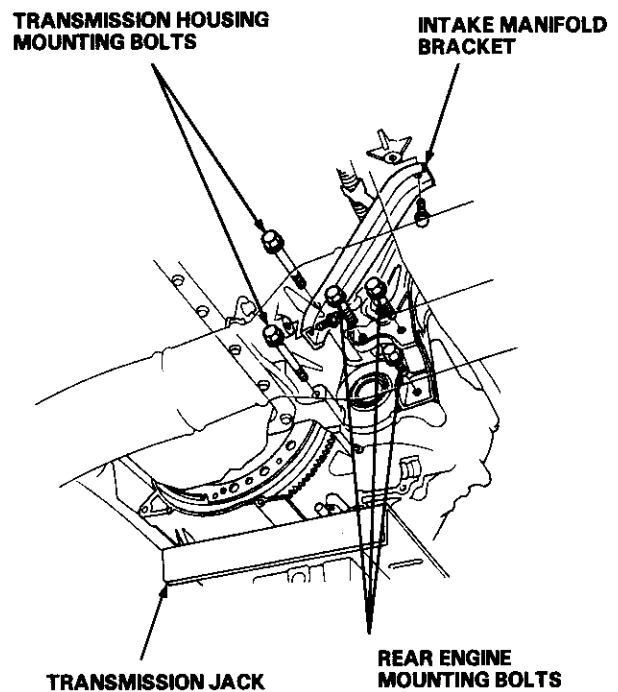

Illustrated Index

Right Side Cover

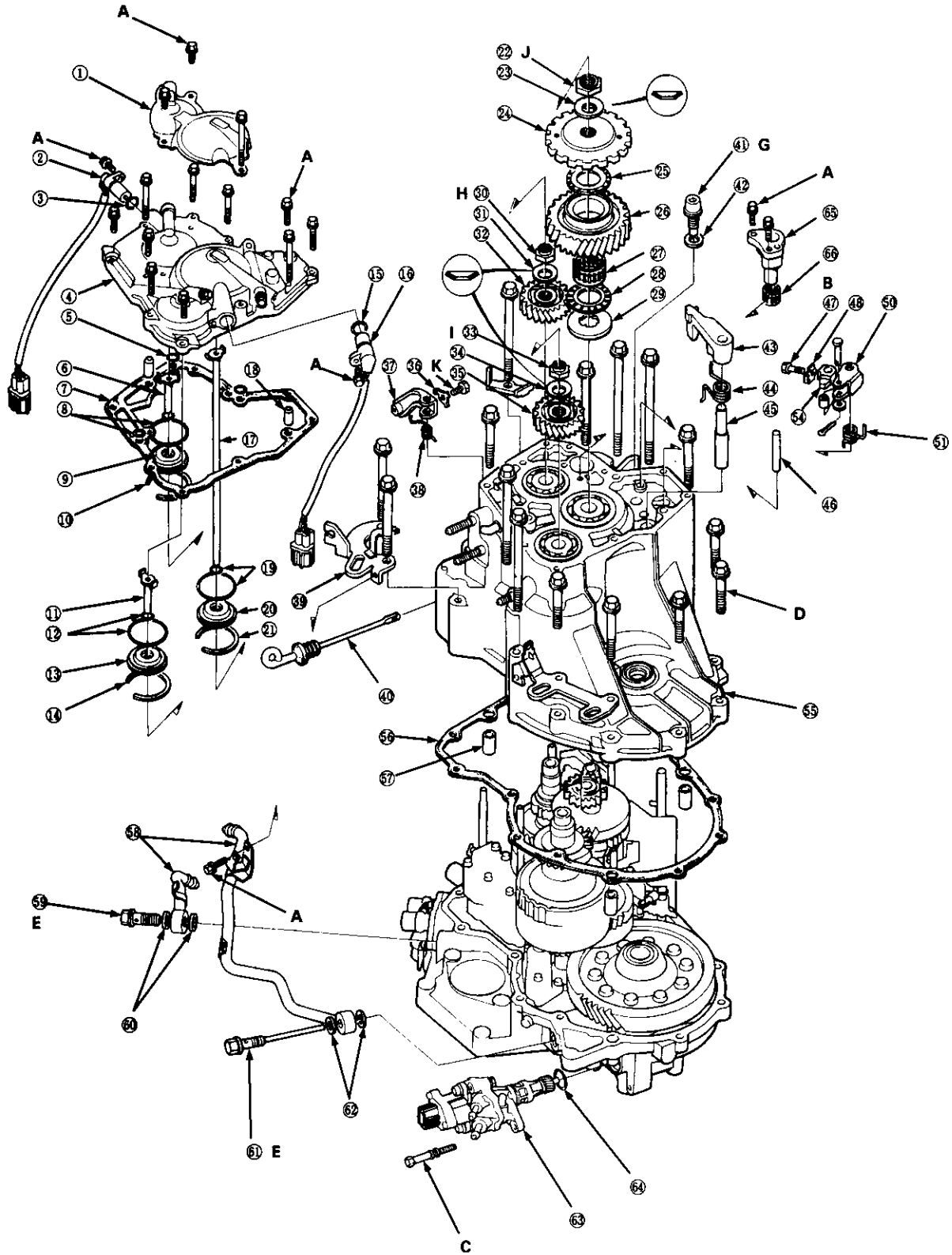



- ① RIGHT SIDE COVER PROTECTOR
- ② MAINSHAFT SPEED SENSOR
- ③ O-RING Replace.
- ④ RIGHT SIDE COVER
- ⑤ O-RING Replace.
- ⑥ 4TH CLUTCH FEED PIPE
- ⑦ RIGHT SIDE COVER GASKET Replace.
- ⑧ O-RINGS Replace.
- ⑨ FEED PIPE GUIDE
- ⑩ SNAP RING
- ⑪ 1ST CLUTCH FEED PIPE
- ⑫ O-RINGS Replace.
- ⑬ FEED PIPE GUIDE
- ⑭ SNAP RING
- ⑮ O-RING Replace.
- ⑯ COUNTERSHAFT SPEED SENSOR
- ⑰ 1ST-HOLD CLUTCH FEED PIPE
- ⑱ DOWEL PIN
- ⑲ O-RINGS Replace.
- ⑳ FEED PIPE GUIDE
- ㉑ SNAP RING
- ㉒ COUNTERSHAFT LOCKNUT, 24 x 1.25 mm
(Flange nut) Replace.
- ㉓ CONICAL SPRING WASHER Replace.
- ㉔ PARKING GEAR
- ㉕ THRUST NEEDLE BEARING
- ㉖ COUNTERSHAFT IDLER GEAR
- ㉗ NEEDLE BEARING
- ㉘ THRUST NEEDLE BEARING
- ㉙ THRUST WASHER
- ㉚ MAINSHAFT LOCKNUT, 24 x 1.25 mm
(Flange nut) Replace.
- NOTE: Left-hand threads
- ㉛ CONICAL SPRING WASHER Replace.
- ㉜ MAINSHAFT IDLER GEAR

- ㉝ SECONDARY SHAFT LOCKNUT, 24 x 1.25 mm
(Flange nut) Replace.
- ㉞ CONICAL SPRING WASHER Replace.
- ㉟ SECONDARY SHAFT IDLER GEAR
- ㊱ LOCK WASHER Replace.
- ㊲ THROTTLE CONTROL LEVER
- ㊳ THROTTLE CONTROL LEVER SPRING
- ㊴ TRANSMISSION HANGER
- ㊵ ATF LEVEL GAUGE
- ㊶ DRAIN PLUG
- ㊷ SEALING WASHER Replace.
- ㊸ PARKING BRAKE PAWL
- ㊹ PARKING BRAKE PAWL SPRING
- ㊺ PARKING BRAKE PAWL SHAFT
- ㊻ PARKING BRAKE PAWL STOPPER
- ㊼ LOCK BOLT
- ㊽ LOCK WASHER Replace.
- ㊾ PARKING BRAKE LEVER
- ㊿ PARKING BRAKE SPRING
- ⑤① PARKING BRAKE STOPPER
- ⑤② TRANSMISSION HOUSING
- ⑤③ TRANSMISSION HOUSING GASKET Replace.
- ⑤④ DOWEL PIN
- ⑤⑤ ATF COOLER PIPES
- ⑤⑥ JOINT BOLT
- ⑤⑦ SEALING WASHERS Replace.
- ⑤⑧ JOINT BOLT
- ⑤⑨ SEALING WASHERS Replace.
- ⑤⑩ VEHICLE SPEED SENSOR/POWER STEERING SPEED SENSOR
- ⑤⑪ O-RING Replace.
- ⑤⑫ REVERSE IDLER GEAR SHAFT HOLDER
- ⑤⑬ NEEDLE BEARING

TORQUE SPECIFICATIONS

Ref No.	Torque Value	Bolt Size	Remarks
A	12 N·m (1.2 kg-m, 9 lb-ft)	6 x 1.0 mm	
B	14 N·m (1.4 kg-m, 10 lb-ft)	6 x 1.0 mm	
C	18 N·m (1.8 kg-m, 13 lb-ft)	8 x 1.25 mm	
D	55 N·m (5.5 kg-m, 40 lb-ft)	10 x 1.25 mm	
E	29 N·m (2.9 kg-m, 21 lb-ft)	12 x 1.25 mm	
G	50 N·m (5.0 kg-m, 36 lb-ft)	18 x 1.5 mm	
H	230 N·m (23.0 kg-m, 166 lb-ft) → 0 → 170 N·m (17.0 kg-m, 123 lb-ft)	24 x 1.25 mm	Joint Bolt Drain Plug Mainshaft Locknut
I	230 N·m (23.0 kg-m, 166 lb-ft) → 0 → 170 N·m (17.0 kg-m, 123 lb-ft)	24 x 1.25 mm	Left-hand threads Secondary Shaft Locknut
J	230 N·m (23.0 kg-m, 166 lb-ft) → 0 → 170 N·m (17.0 kg-m, 123 lb-ft)	24 x 1.25 mm	Locknut Countershaft Locknut
K	8 N·m (0.8 kg-m, 5.8 lb-ft)	5 x 0.8 mm	

Illustrated Index

Transmission Housing

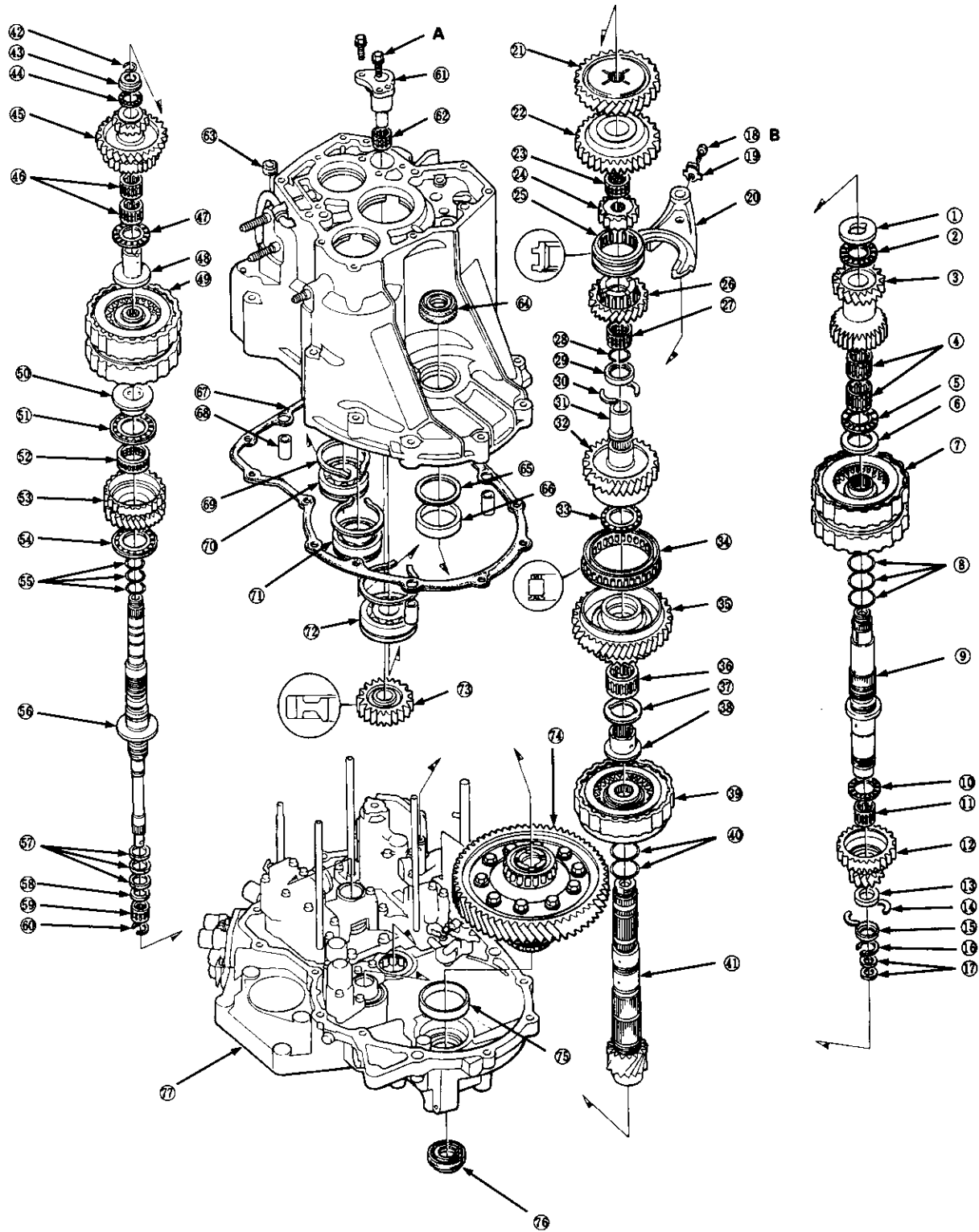

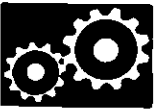

- ① THRUST WASHER
- ② THRUST NEEDLE BEARING
- ③ SECONDARY SHAFT 2ND GEAR
- ④ NEEDLE BEARINGS
- ⑤ THRUST NEEDLE BEARING
- ⑥ SPLINED WASHER Selective part
- ⑦ 1ST/2ND CLUTCH ASSEMBLY
- ⑧ O-RINGS Replace.
- ⑨ SECONDARY SHAFT
- ⑩ THRUST NEEDLE BEARING
- ⑪ NEEDLE BEARING
- ⑫ SECONDARY SHAFT 1ST GEAR
- ⑬ DISTANCE COLLAR, 5.0 mm
- ⑭ COTTERS, 29 mm
- ⑮ COTTER RETAINER
- ⑯ SNAP RING
- ⑰ SEALING RINGS, 32 mm
- ⑱ LOCK BOLT
- ⑲ LOCK WASHER Replace.
- ⑳ SHIFT FORK
- ㉑ COUNTERSHAFT 2ND GEAR
- ㉒ COUNTERSHAFT REVERSE GEAR
- ㉓ NEEDLE BEARING
- ㉔ REVERSE SELECTOR HUB
- ㉕ REVERSE SELECTOR
- ㉖ COUNTERSHAFT 4TH GEAR
- ㉗ NEEDLE BEARING
- ㉘ SNAP RING
- ㉙ COLLAR, 32 mm
- ㉚ COTTERS, 29 mm
- ㉛ DISTANCE COLLAR
- ㉜ COUNTERSHAFT 3RD GEAR
- ㉝ THRUST NEEDLE BEARING
- ㉞ ONE-WAY CLUTCH
- ㉟ COUNTERSHAFT 1ST GEAR
- ㊱ NEEDLE BEARING
- ㊲ THRUST WASHER
- ㊳ COUNTERSHAFT 1ST GEAR COLLAR
- ㊴ 1ST-HOLD CLUTCH ASSEMBLY

- ㊵ O-RINGS Replace.
- ㊶ COUNTERSHAFT
- ㊷ SNAP RING
- ㊸ COLLAR
- ㊹ THRUST NEEDLE BEARING
- ㊺ MAINSHAFT 4TH/REVERSE GEAR
- ㊻ NEEDLE BEARINGS
- ㊼ THRUST NEEDLE BEARING
- ㊽ 4TH GEAR COLLAR
- ㊾ 3RD/4TH CLUTCH ASSEMBLY
- ㊿ 3RD GEAR COLLAR
- ① THRUST NEEDLE BEARING
- ② NEEDLE BEARING
- ③ MAINSHAFT 3RD GEAR
- ④ THRUST NEEDLE BEARING
- ⑤ O-RINGS Replace.
- ⑥ MAINSHAFT
- ⑦ SEALING RINGS, 35 mm
- ⑧ SEALING RING, 29 mm
- ⑨ NEEDLE BEARING
- ⑩ SET RING
- ⑪ REVERSE IDLER GEAR SHAFT HOLDER
- ⑫ NEEDLE BEARING
- ⑬ OIL SEAL Replace.
- ⑭ TRANSMISSION HOUSING OIL SEAL Replace.
- ⑮ THRUST SHIM Selective part
- ⑯ BEARING OUTER RACE
- ⑰ TRANSMISSION HOUSING GASKET Replace.
- ⑱ DOWEL PIN
- ⑲ SNAP RING
- ㉑ TRANSMISSION HOUSING MAINSHAFT BEARING
- ㉒ TRANSMISSION HOUSING SECONDARY SHAFT BEARING
- ㉓ TRANSMISSION HOUSING COUNTERSHAFT BEARING
- ㉔ REVERSE IDLER GEAR
- ㉕ DIFFERENTIAL ASSEMBLY
- ㉖ BEARING OUTER RACE
- ㉗ TORQUE CONVERTER HOUSING OIL SEAL Replace.
- ㉘ TORQUE CONVERTER HOUSING

TORQUE SPECIFICATIONS

Ref No.	Torque Value	Bolt Size	Remarks
A	12 N·m (1.2 kg-m, 9 lb-ft)	6 x 1.0 mm	
B	14 N·m (1.4 kg-m, 10 lb-ft)	6 x 1.0 mm	

Illustrated Index

Torque Converter Housing

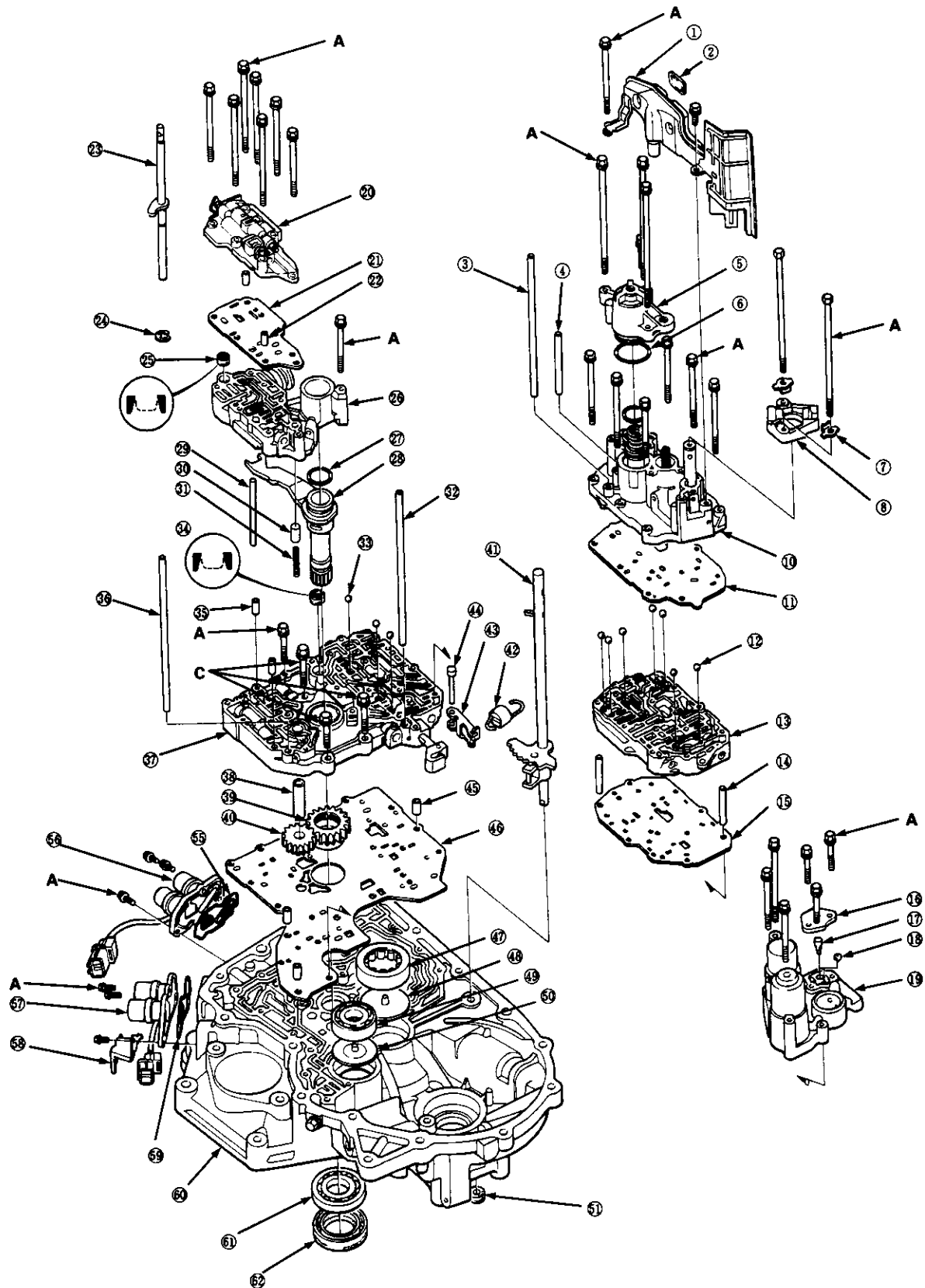



- ① ATF STRAINER
- ② MAGNET
- ③ OIL FEED PIPE
- ④ OIL FEED PIPE
- ⑤ 4TH ACCUMULATOR COVER
- ⑥ O-RING Replace.
- ⑦ LOCK WASHER Replace.
- ⑧ SERVO DETENT BASE
- ⑩ SERVO BODY
- ⑪ SERVO SEPARATOR PLATE
- ⑫ CHECK BALL
- ⑬ SECONDARY VALVE BODY
- ⑭ DOWEL PIN
- ⑮ SECONDARY SEPARATOR PLATE
- ⑯ ACCUMULATOR BODY COVER
- ⑰ 1ST ACCUMULATOR CHOKE
- ⑱ CHECK BALL
- ⑲ 1ST/2ND ACCUMULATOR BODY
- ⑳ THROTTLE VALVE BODY
- ㉑ THROTTLE SEPARATOR PLATE
- ㉒ DOWEL PIN
- ㉓ THROTTLE CONTROL SHAFT
- ㉔ E RING Replace.
- ㉕ FILTER Replace.
- ㉖ REGULATOR VALVE BODY
- ㉗ O-RING Replace.
- ㉘ STATOR SHAFT
- ㉙ STOPPER SHAFT
- ㉚ TORQUE CONVERTER CHECK VALVE
- ㉛ TORQUE CONVERTER CHECK VALVE SPRING

- ㉜ OIL FEED PIPE
- ㉝ CHECK BALL
- ㉞ FILTER Replace.
- ㉟ DOWEL PIN
- ㊱ OIL FEED PIPE
- ㊲ MAIN VALVE BODY
- ㊳ OIL PUMP DRIVEN GEAR SHAFT
- ㊴ OIL PUMP DRIVE GEAR
- ㊵ OIL PUMP DRIVEN GEAR
- ㊶ CONTROL SHAFT
- ㊷ DETENT SPRING
- ㊸ DETENT ARM
- ㊹ DETENT ARM SHAFT
- ㊺ DOWEL PIN
- ㊻ MAIN SEPARATOR PLATE
- ㊼ COUNTERSHAFT NEEDLE BEARING
- ㊽ OIL GUIDE PLATE
- ㊾ SECONDARY SHAFT BALL BEARING
- ㊿ OIL GUIDE PLATE
- ① OIL SEAL
- ② SHIFT CONTROL SOLENOID FILTER/GASKET Replace.
- ③ SHIFT CONTROL SOLENOID VALVE ASSEMBLY
- ④ LOCK-UP CONTROL SOLENOID VALVE ASSEMBLY
- ⑤ CONNECTOR HOLDER
- ⑥ LOCK-UP CONTROL SOLENOID FILTER/GASKET Replace.
- ⑦ TORQUE CONVERTER HOUSING
- ⑧ MAINSHAFT BALL BEARING
- ⑨ OIL SEAL Replace.

TORQUE SPECIFICATIONS

Ref No.	Torque Value	Bolt Size	Remarks
A	12 N·m (1.2 kg-m , 9 lb-ft)	6 x 1.0 mm	
C	18 N·m (1.8 kg-m , 13 lb-ft)	8 x 1.25 mm	

Right Side Cover

Removal

NOTE:

- Clean all parts thoroughly in solvent or carburetor cleaner and dry with compressed air.
- Blow out all passages.
- When removing the transmission right side cover, replace the following:
 - Right side cover gasket
 - Lock washers
 - Transmission housing gasket
 - O-rings
 - Each shaft locknut and conical spring washer
 - Sealing washers

1. Remove the eleven bolts securing the right side cover, then remove the right side cover.

NOTE:

It is not necessary to remove the right side cover protector.

2. Slip the special tool onto the mainshaft.

MAINSHAFT HOLDER
07GAB - PF50100 or
07GAB - PF50101

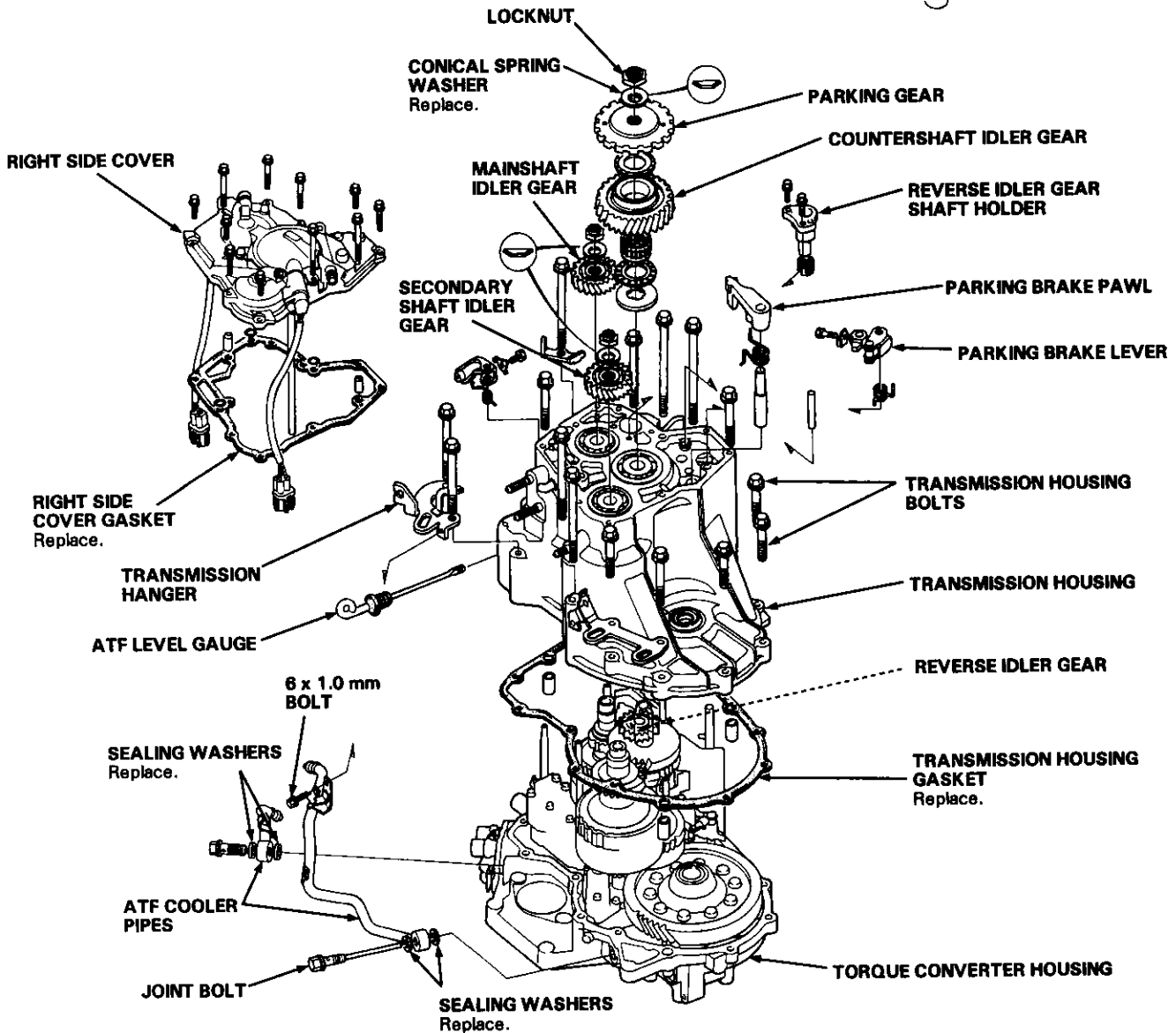
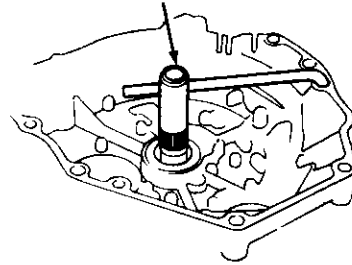



- Engage the parking brake pawl with the parking gear.
- Cut the lock tabs of each shaft locknut using a chisel as shown. Then remove the locknuts and conical spring washers from each shaft.

NOTE:

- Mainshaft locknut has left-hand threads.
- Clean the old locknuts; they are used to install the press fit idler gears on the mainshaft and secondary shaft and the parking gear on the countershaft.
- Always wear safety glasses.

CAUTION:

Keep all of the chiseled particles out of the transmission.

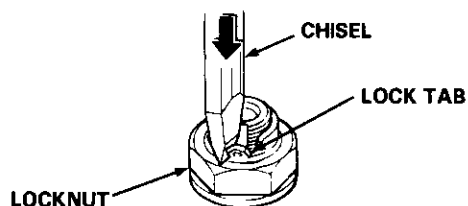

- Remove the special tool from the mainshaft after removing the locknuts.
- Remove the parking gear using a puller from the countershaft as shown. Then remove the idler gears using a puller from the mainshaft and secondary shaft.

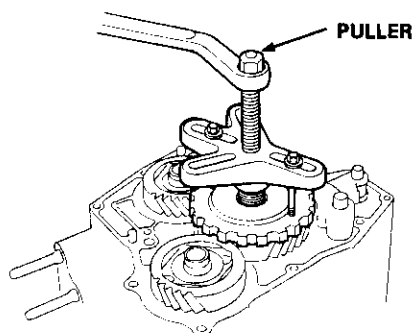

- Remove the countershaft idler gear, needle bearing, thrust needle bearing, and thrust washer from the countershaft.
- Remove the parking brake pawl, spring, shaft, and stopper from the housing.
- Remove the throttle control lever and spring from the throttle control shaft.
- Remove the ATF cooler pipe mounting bolt from the transmission hanger.
- Remove the transmission housing mounting bolts.

- Remove the reverse idler gear shaft holder.

NOTE:

The steel ball does not pop out because it is staked in the shaft.

- Move the reverse idler gear to disengage it from the countershaft and mainshaft reverse gears as shown.

NOTE:

The transmission housing will not separate from the torque converter housing if the reverse idler gear is not removed.

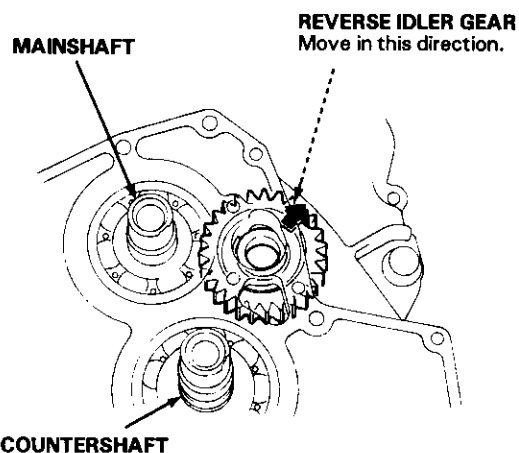

- Align the spring pin of the control shaft with the transmission housing groove by turning the control shaft.

- Install the special tool on the transmission housing, then remove the housing as shown.

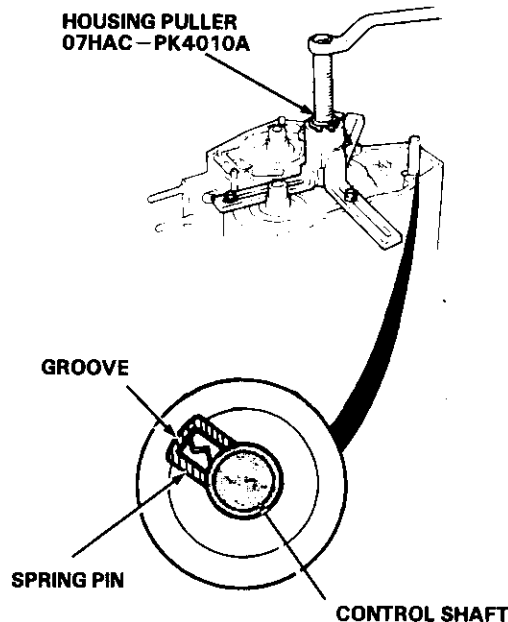

Transmission Housing

Removal

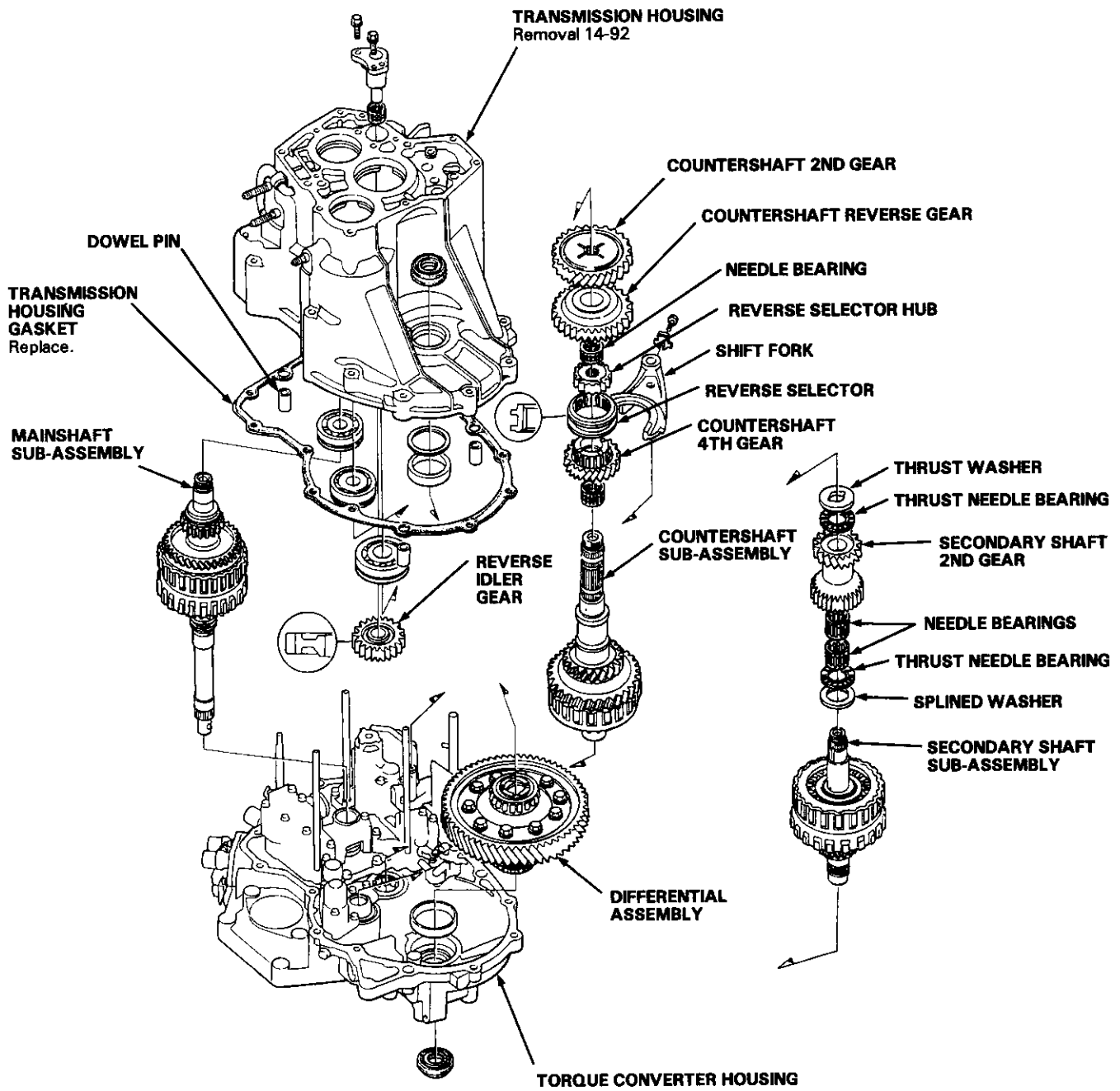



NOTE:

- Clean all parts thoroughly in solvent or carburetor cleaner and dry with compressed air.
- Blow out all passages.
- When removing the transmission housing, replace the following:
 - Transmission housing gasket
 - Lock washer

1. Remove the transmission housing (see page 14-92).
2. Remove the reverse idler gear from the transmission housing.
3. Remove the countershaft 2nd gear, reverse gear, secondary shaft 2nd gear, thrust washer, and thrust needle bearing together from the countershaft and secondary shaft.
4. Remove the lock bolt securing the shift fork, then remove the fork with the reverse selector from the countershaft.
5. Remove the needle bearings, thrust needle bearing, and splined washer from the secondary shaft.
6. Remove the secondary shaft sub-assembly.
7. Remove the mainshaft sub-assembly.
8. Remove the countershaft sub-assembly.
9. Remove the differential assembly.

Torque Converter Housing/Valve Body

Removal

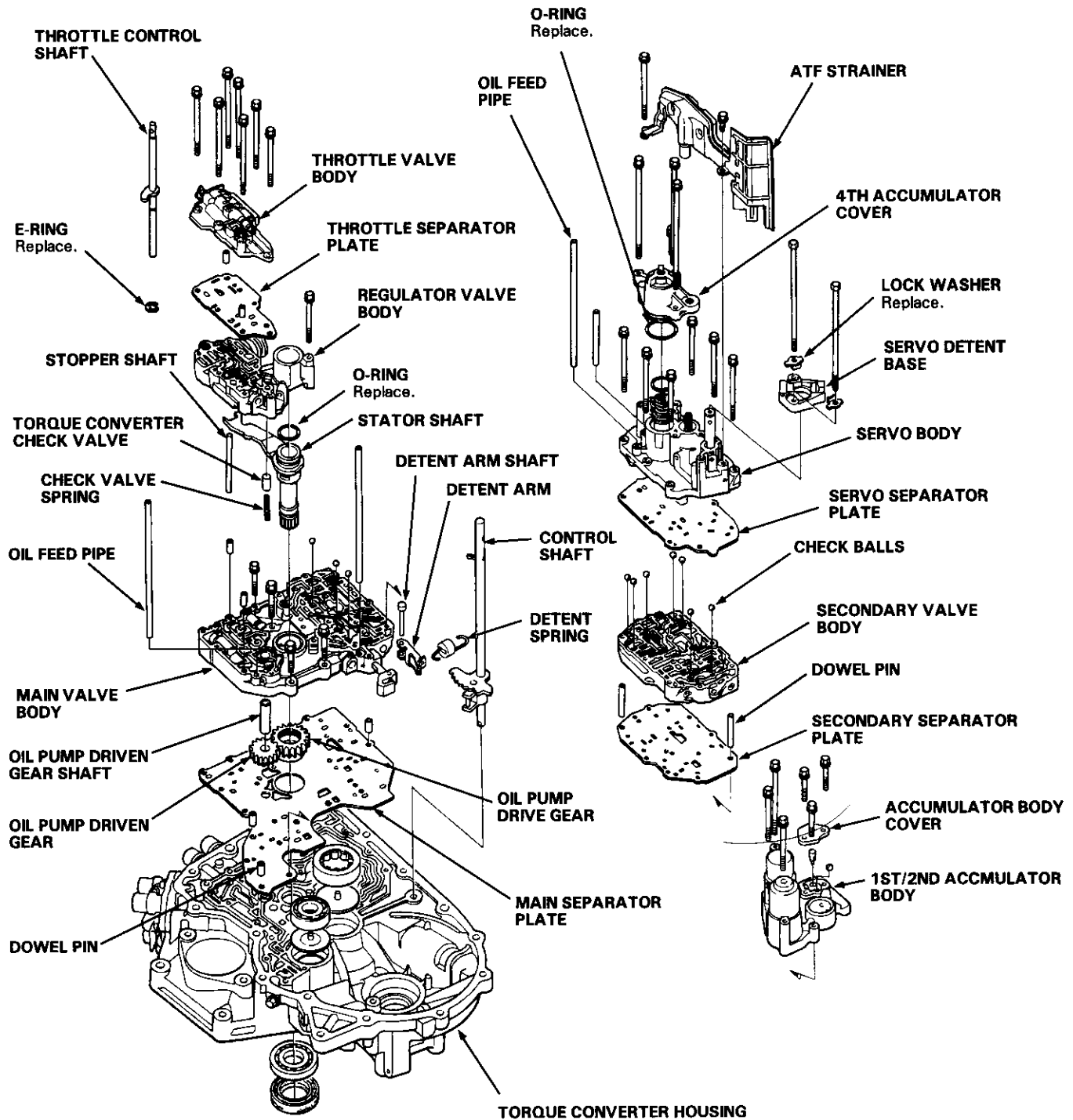



NOTE:

- Clean all parts thoroughly in solvent or carburetor cleaner and dry with compressed air.
- Blow out all passages.
- When removing the valve body, replace the following:
 - O-rings
 - Lock washers

1. Remove the two bolts securing the servo detent base, then remove the servo detent base.
2. Remove the two bolts securing the ATF strainer, then remove the ATF strainer.
3. Remove the oil feed pipes from the servo body and main valve body.
4. Remove the three bolts securing the 4th accumulator cover, then remove the 4th accumulator cover.

NOTE:

The 4th accumulator cover is spring loaded, to prevent stripping the threads in the servo body, press down on the accumulator cover while unscrewing the bolts in a crisscross pattern.

5. Remove the seven bolts securing the servo body, then remove the servo body and separator plate.
6. Remove the secondary valve body and separator plate.
7. Remove the seven bolts securing the throttle valve body, then remove the throttle valve body and separator plate.
8. Remove the bolt securing the regulator valve body, then remove the regulator valve body.

9. Remove the stator shaft and stopper shaft.

10. Remove the detent spring from the detent arm, then remove the control shaft from the torque converter housing.
11. Remove the detent arm and detent arm shaft from the main valve body.
12. Remove the four bolts securing the main valve body, then remove the main valve body.
13. Remove the six bolts securing the 1st/2nd accumulator body, then remove the 1st/2nd accumulator body.
14. Remove the oil pump driven gear shaft, then remove the oil pump gears.
15. Remove the main separator plate with three dowel pins.

Valve Body

Repair

NOTE:

This repair is only necessary if one or more of the valves in a valve body do not slide smoothly in their bores. You may use this procedure to free the valves in the valve bodies.

1. Soak a sheet of #600 abrasive paper in ATF for about 30 minutes.
2. Carefully tap the valve body so the sticking valve drops out of its bore.

CAUTION:

It may be necessary to use a small screwdriver to pry the valve free. Be careful not to scratch the bore with the screwdriver.

3. Inspect the valve for any scuff marks. Use the ATF-soaked #600 paper to polish off any burrs that are on the valve, then wash the valve in solvent and dry it with compressed air.
4. Roll up half a sheet of ATF-soaked #600 paper and insert it in the valve bore of the sticking valve. Twist the paper slightly, so that it unrolls and fits the bore tightly, then polish the bore by twisting the paper as you push it in and out.

CAUTION:

The valve body is aluminum and doesn't require much polishing to remove any burrs.

ATF-soaked
600 abrasive
paper

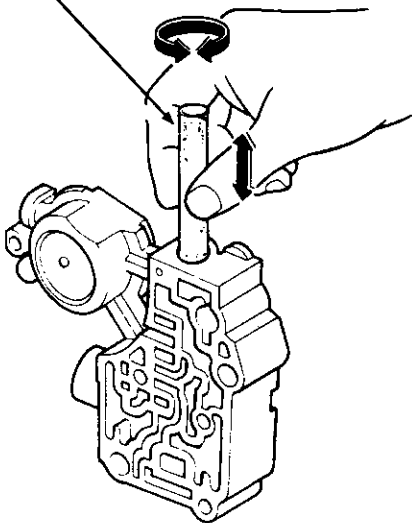

5. Remove the #600 paper. Thoroughly wash the entire valve body in solvent, then dry with compressed air.
6. Coat the valve with ATF, then drop it into its bore. It should drop to the bottom of the bore under its own weight. If not, repeat step 4, then retest.

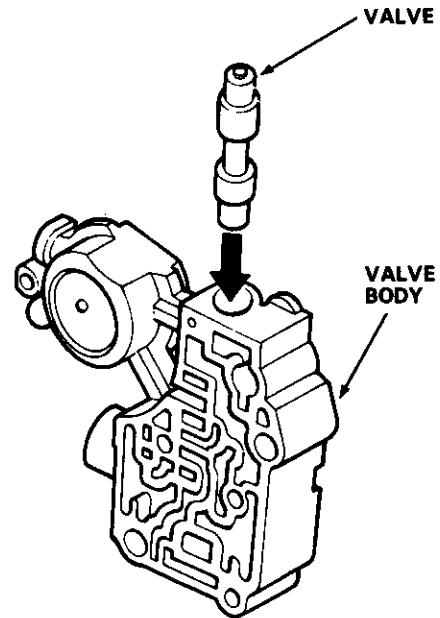

7. Remove the valve and thoroughly clean it and the valve body with solvent. Dry all parts with compressed air, then reassemble using ATF as a lubricant.



Valve

Assembly

NOTE:

Coat all parts with ATF before assembly.

- Install the valve, valve spring and cap in the valve body, and secure with the roller.

- Set the spring in the valve and install them in the valve body. Push the spring in with a screwdriver, then install the spring seat.

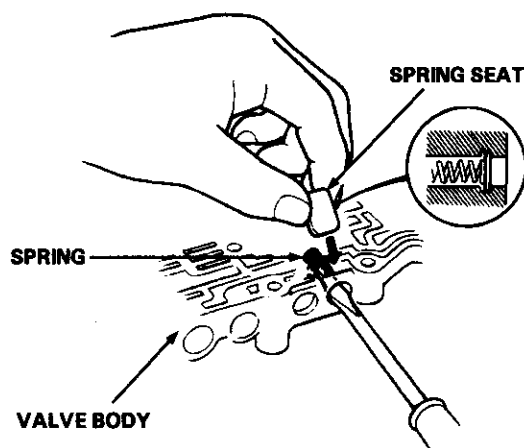
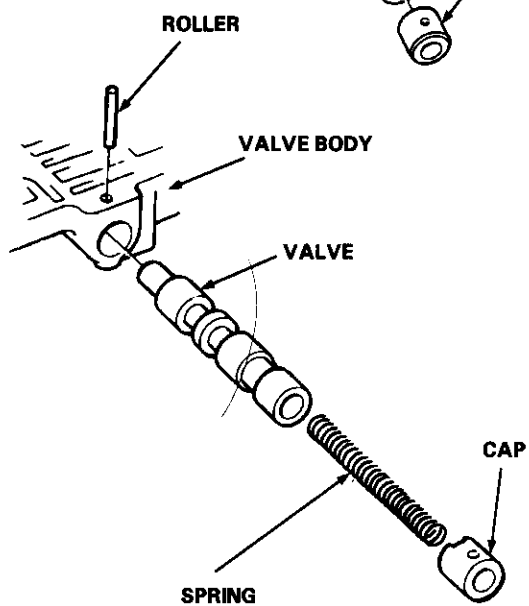
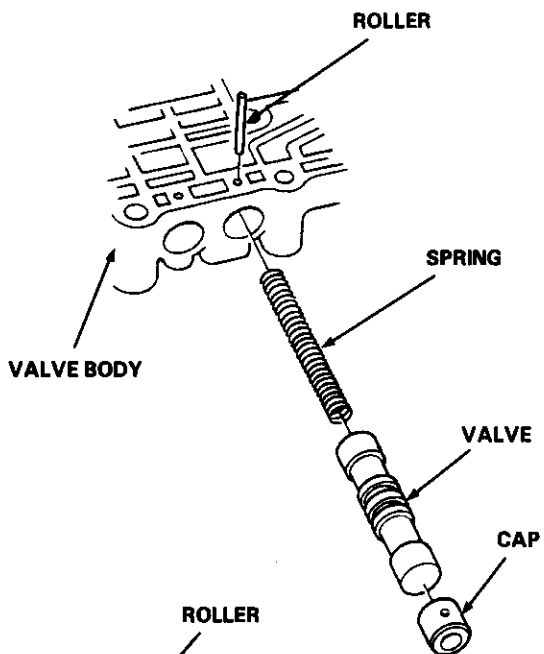

Valve Caps

Description

- Caps with one projected tip and one flat end are installed with the flat end toward the inside of the valve body.
- Caps with a projected tip on each end are installed with the smaller tip toward the inside of the valve body. The small tip is a spring guide.

TOWARD OUTSIDE OF VALVE BODY



TOWARD INSIDE OF VALVE BODY

- Caps with hollow ends are installed with the hollow away from the inside of the valve body.
- Caps with notched ends are installed with the notch toward the inside of the valve body.
- Caps with flat ends and a hole through the center are installed with the smaller hole toward the inside of the valve body.

TOWARD OUTSIDE OF VALVE BODY

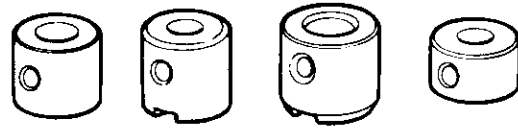

TOWARD INSIDE OF VALVE BODY

- Caps with one projected tip and hollow end are installed with the tip toward the inside of the valve body. The tip is a spring guide.

TOWARD OUTSIDE OF VALVE BODY



TOWARD INSIDE OF VALVE BODY

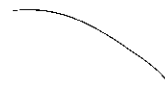



Oil Pump Inspection

1. Install the oil pump gears and oil pump driven gear shaft in the main valve body.

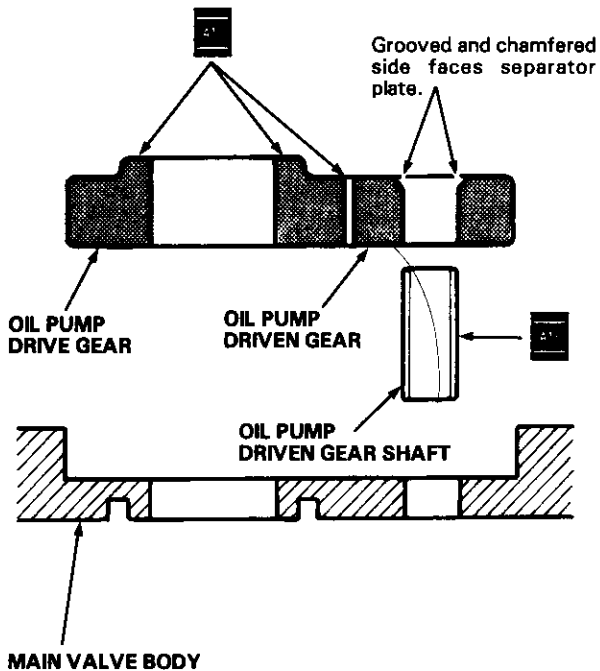
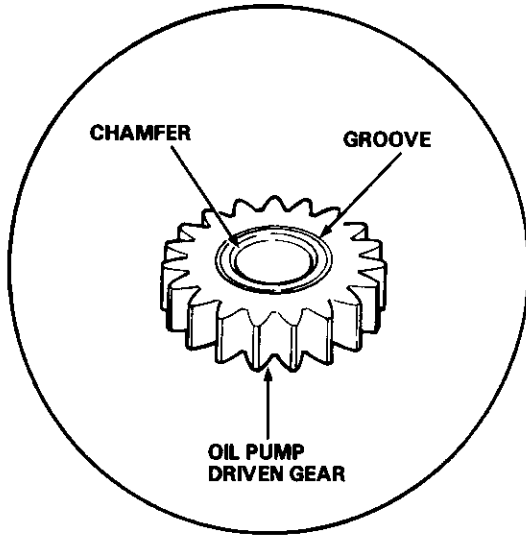

2. Measure the side clearance of the oil pump drive and driven gears.

Oil Pump Gears Side (Radial) Clearance:

Standard (New):

Oil Pump Drive gear

0.210—0.265 mm (0.0083—0.0104 in)

Oil Pump Driven gear

0.035—0.063 mm (0.0014—0.0025 in)

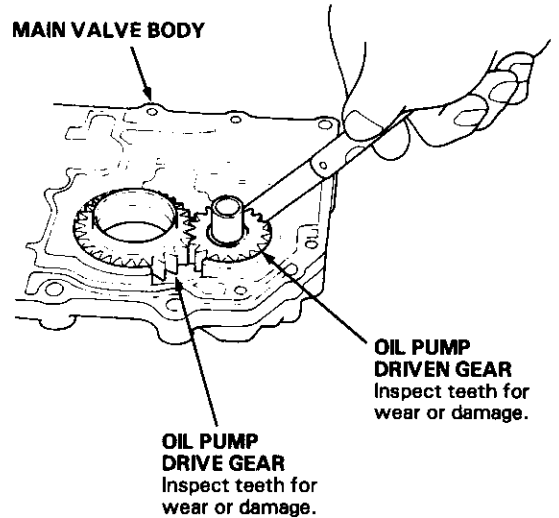

3. Remove the oil pump driven gear shaft. Measure the thrust clearance of the oil pump driven gear-to-valve body.

Oil Pump Drive/Driven Gear Thrust (Axial) Clearance:

Standard (New): 0.03—0.05 mm (0.001—0.002 in)

Service Limit: 0.07 mm (0.003 in)

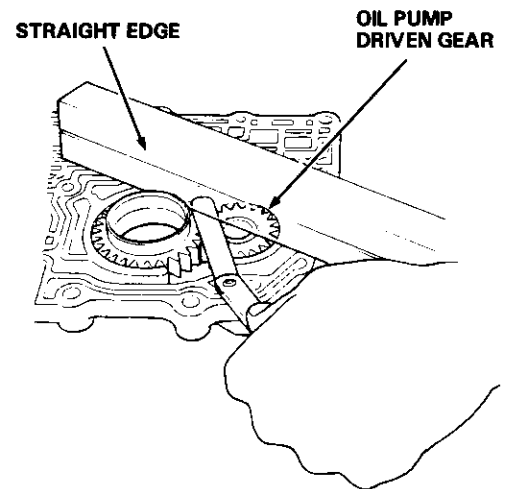

Main Valve Body

Disassembly/Inspection/Reassembly

NOTE:

- Clean all parts thoroughly in solvent or carburetor cleaner, and dry with compressed air. Blow out all passages.
- Replace valve body as an assembly if any parts are worn or damaged.
- Check all valves for free movement. If any fail to slide freely, see Valve Body Repair on page 14-98.

CAUTION:

Do not use a magnet to remove the check balls; it may magnetize the balls.

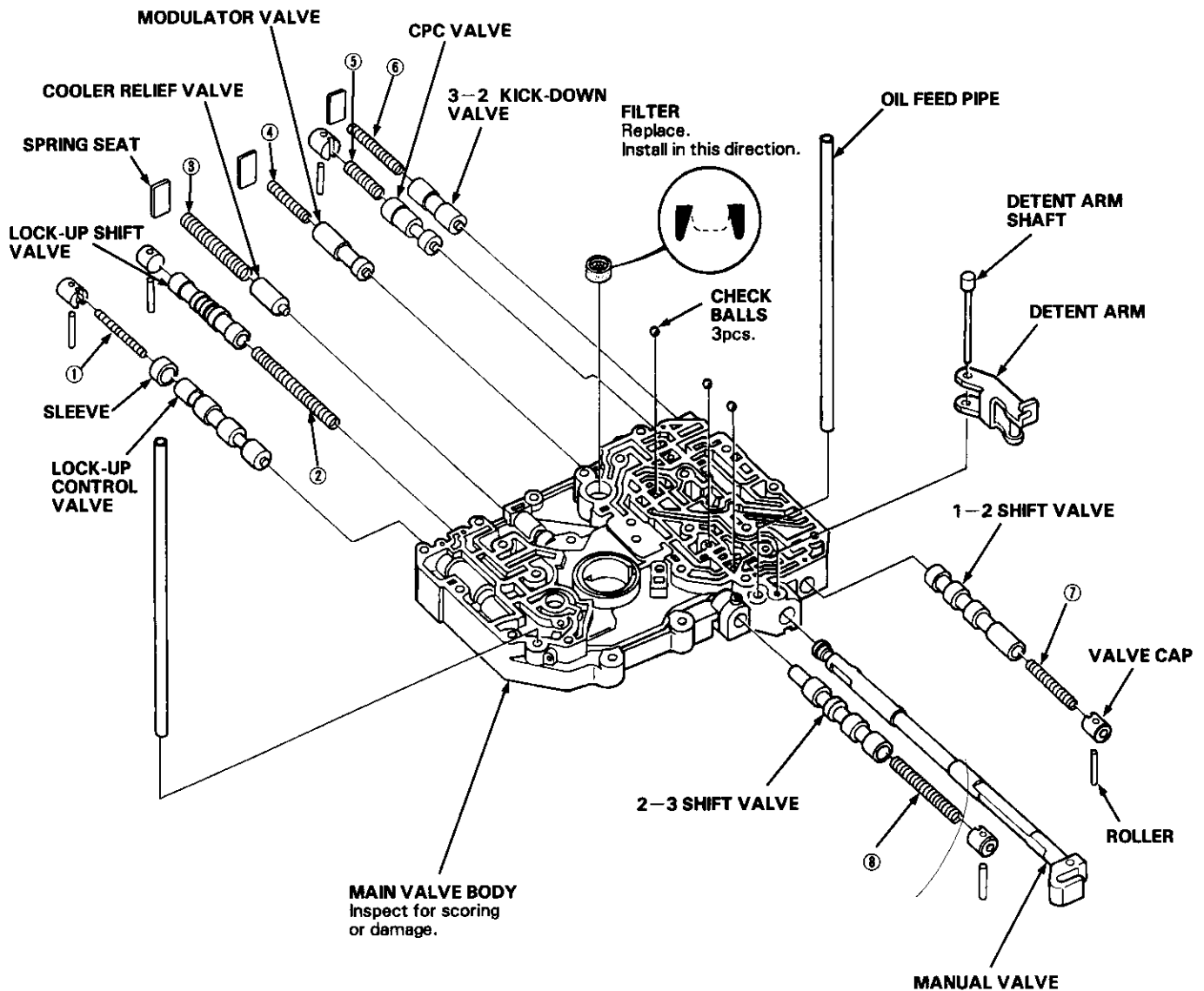

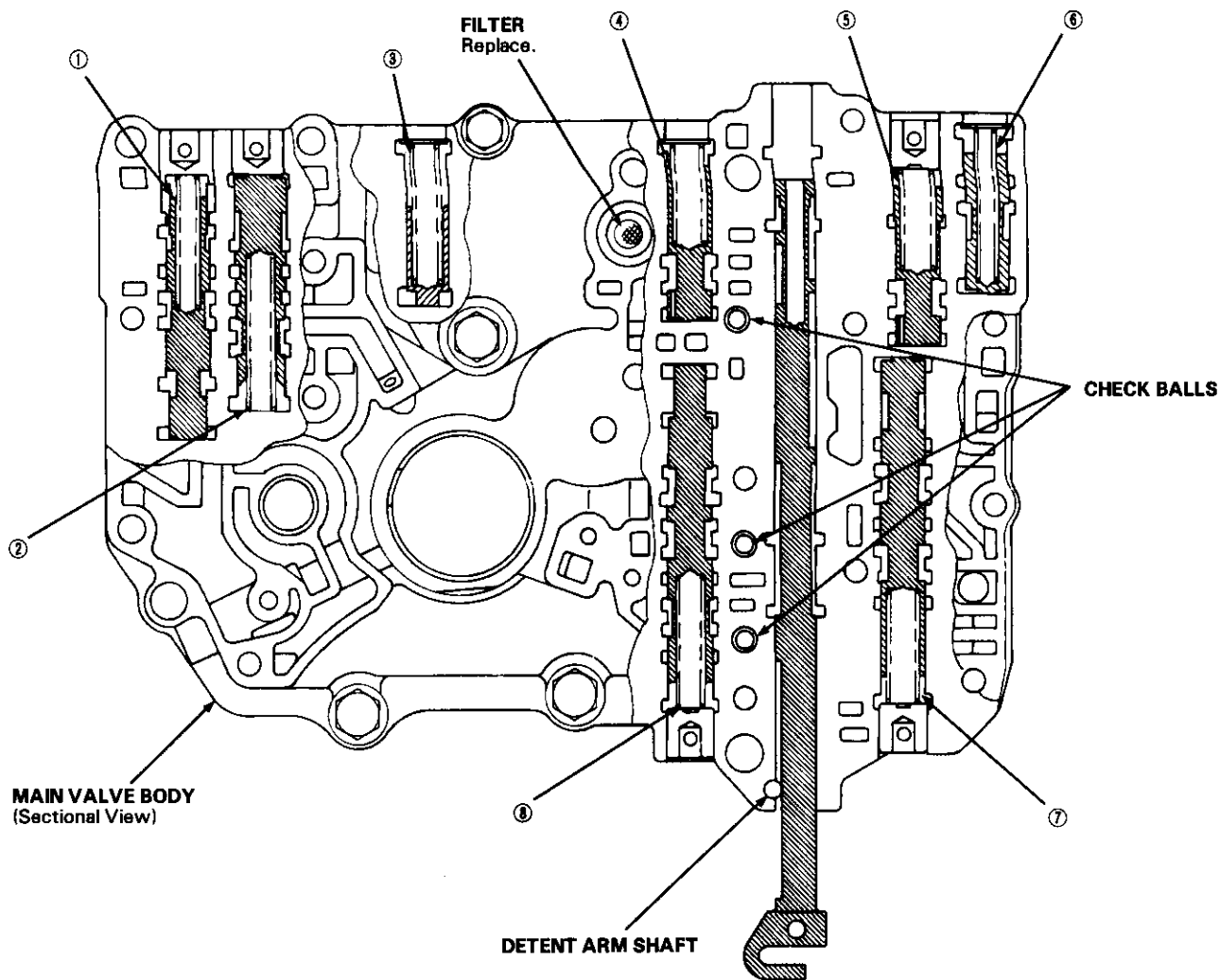

SPRING SPECIFICATIONS

Unit: mm (in)

No.	Spring	Standard (New)			
		Wire Dia.	O.D.	Free Length	No. of Coils
①	Lock-up control valve spring	0.70 (0.028)	6.60 (0.260)	38.00 (1.496)	14.1
②	Lock-up shift valve spring	0.90 (0.035)	7.60 (0.299)	73.70 (2.902)	32.0
③	Cooler relief valve spring	1.10 (0.043)	8.40 (0.331)	46.80 (1.843)	17.0
④	Modulator valve spring	1.40 (0.055)	9.40 (0.370)	33.00 (1.299)	10.5
⑤	CPC valve spring	1.40 (0.055)	9.40 (0.370)	33.00 (1.299)	10.5
⑥	3-2 kick-down valve spring	1.20 (0.047)	7.10 (0.280)	46.90 (1.846)	20.6
⑦	1-2 shift valve spring	1.00 (0.039)	8.60 (0.339)	41.30 (1.626)	16.9
⑧	2-3 shift valve spring	0.90 (0.035)	7.60 (0.299)	57.00 (2.244)	26.8

Secondary Valve Body

Disassembly/Inspection/Reassembly

NOTE:

- Clean all parts thoroughly in solvent or carburetor cleaner, and dry with compressed air. Blow out all passages.
- Check all valves for free movement. If any fail to slide freely, see Valve Body Repair on page 14-98.
- Coat all parts with ATF before assembling.
- Replace the valve body as an assembly if any parts are worn or damaged.

CAUTION:

Do not use a magnet to remove the check balls; it may magnetize the balls.

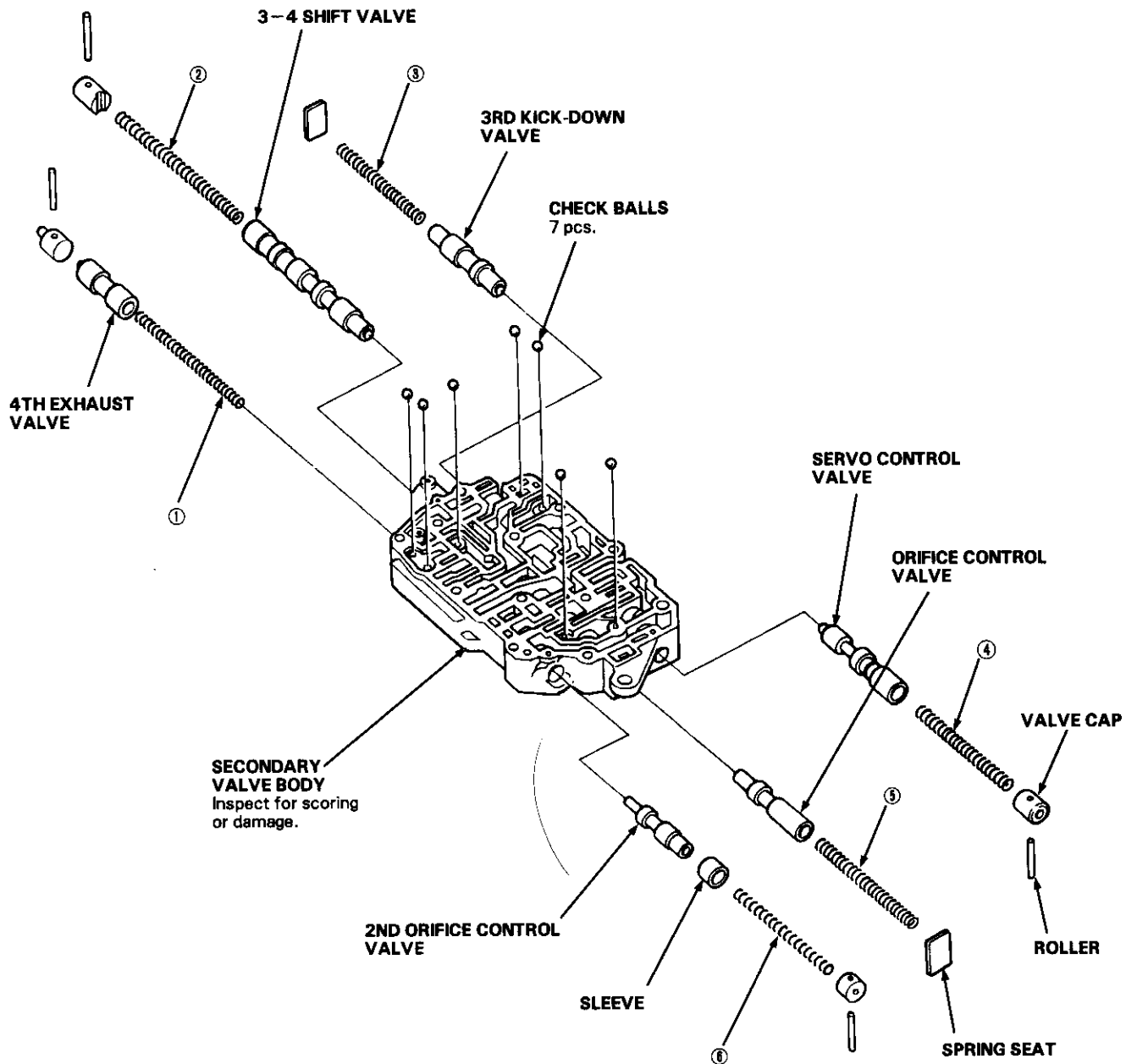

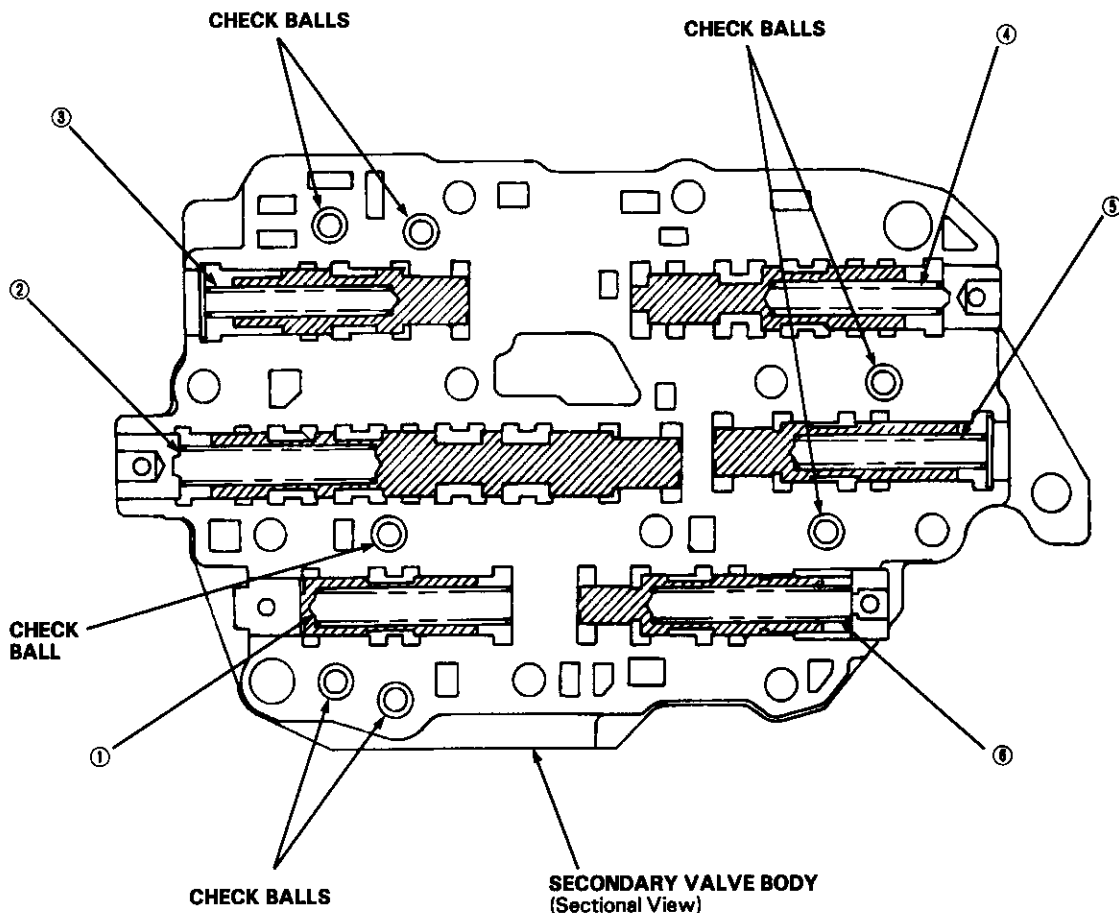

SPRING SPECIFICATIONS

Unit: mm (in)

No.	Springs	Standard (New)			
		Wire Dia.	O.D.	Free Length	No. of Coils
①	4th exhaust valve spring	0.90 (0.035)	7.10 (0.280)	60.80 (2.394)	28.9
②	3—4 shift valve spring	0.90 (0.035)	7.60 (0.299)	57.00 (2.244)	26.8
③	3rd kick-down valve spring	1.10 (0.043)	7.60 (0.299)	48.30 (1.902)	23.3
④	Servo control valve spring	1.00 (0.039)	8.10 (0.319)	52.60 (2.071)	22.4
⑤	Orifice control valve spring	0.80 (0.031)	6.60 (0.260)	52.50 (2.067)	33.0
⑥	2nd orifice control valve spring	0.60 (0.024)	6.60 (0.260)	58.30 (2.295)	15.8

Regulator Valve Body

Disassembly/Inspection/Reassembly

NOTE:

- Clean all parts thoroughly in solvent or carburetor cleaner, and dry with compressed air. Blow out all passages.
- Replace valve body as an assembly if any parts are worn or damaged.
- Check all valves for free movement. If any fail to slide freely, see Valve Body Repair on page 14-98.

1. Hold the regulator spring cap in place while removing the stopper bolt. Once the stopper bolt is removed, release the spring cap slowly.

CAUTION:

The regulator spring cap can pop out when the lock bolt is removed.

2. Reassembly is the reverse order of disassembly.

NOTE:

- Coat all parts with ATF.
- Align the hole in the regulator spring cap with the hole in the valve body; then press the spring cap into the valve body and tighten the stopper bolt.

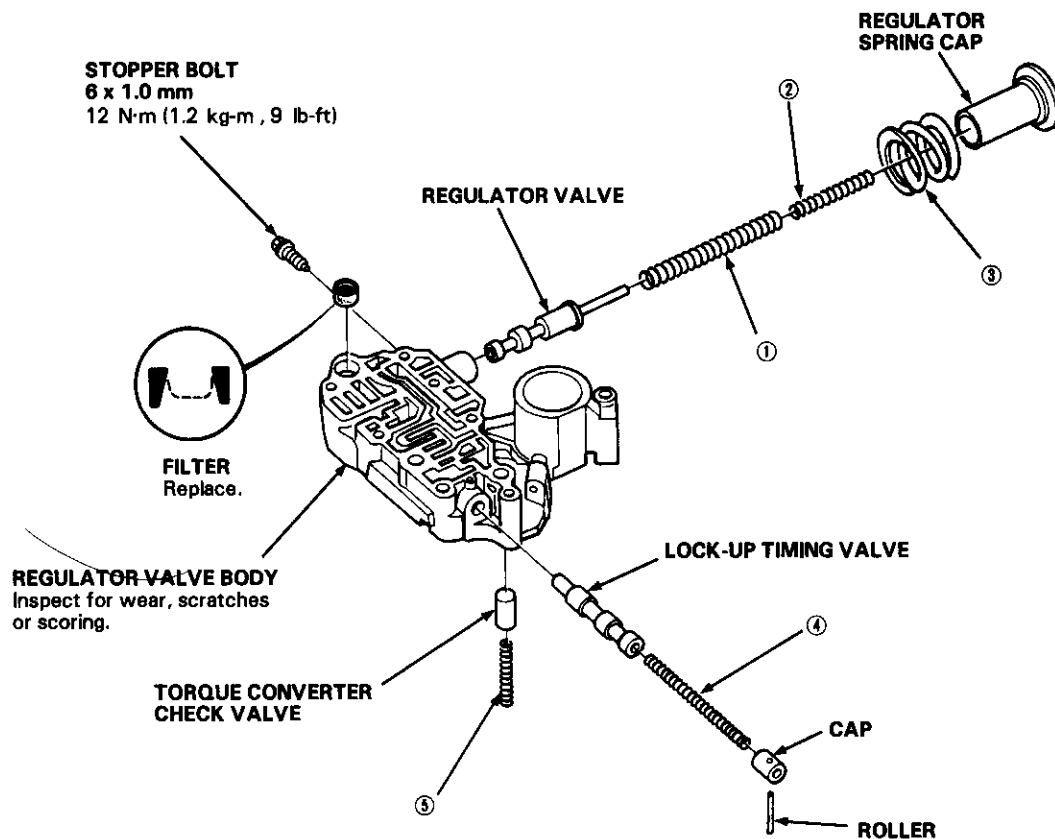

SPRING SPECIFICATIONS

Unit: mm (in)

No.	Springs	Standard (New)				
		Wire Dia.	O.D.	Free Length	No. of Coils	
①	Regulator valve spring A	F22A1 engine	1.80 (0.071)	14.70 (0.579)	86.50 (3.406)	16.5
		H23A1 engine	1.80 (0.071)	14.70 (0.579)	88.60 (3.488)	16.5
②	Regulator valve spring B		1.80 (0.071)	9.60 (0.378)	44.00 (1.732)	12.7
③	Stator reaction spring		4.50 (0.177)	35.40 (1.394)	30.30 (1.193)	1.92
④	Lock-up timing valve spring		0.80 (0.031)	6.60 (0.260)	51.10 (2.012)	14.7
⑤	Torque converter check valve spring		1.10 (0.043)	8.40 (0.331)	36.40 (1.433)	12.0



Throttle Valve Body

Disassembly/Inspection/Reassembly

NOTE:

- Clean all parts thoroughly in solvent or carburetor cleaner, and dry with compressed air. Blow out all passages.
- Check all valves for free movement. If any fail to slide freely, see Valve Body Repair on page 14-98.
- Coat all parts with ATF before assembling.
- Replace the valve body as an assembly if any parts are worn or damaged.

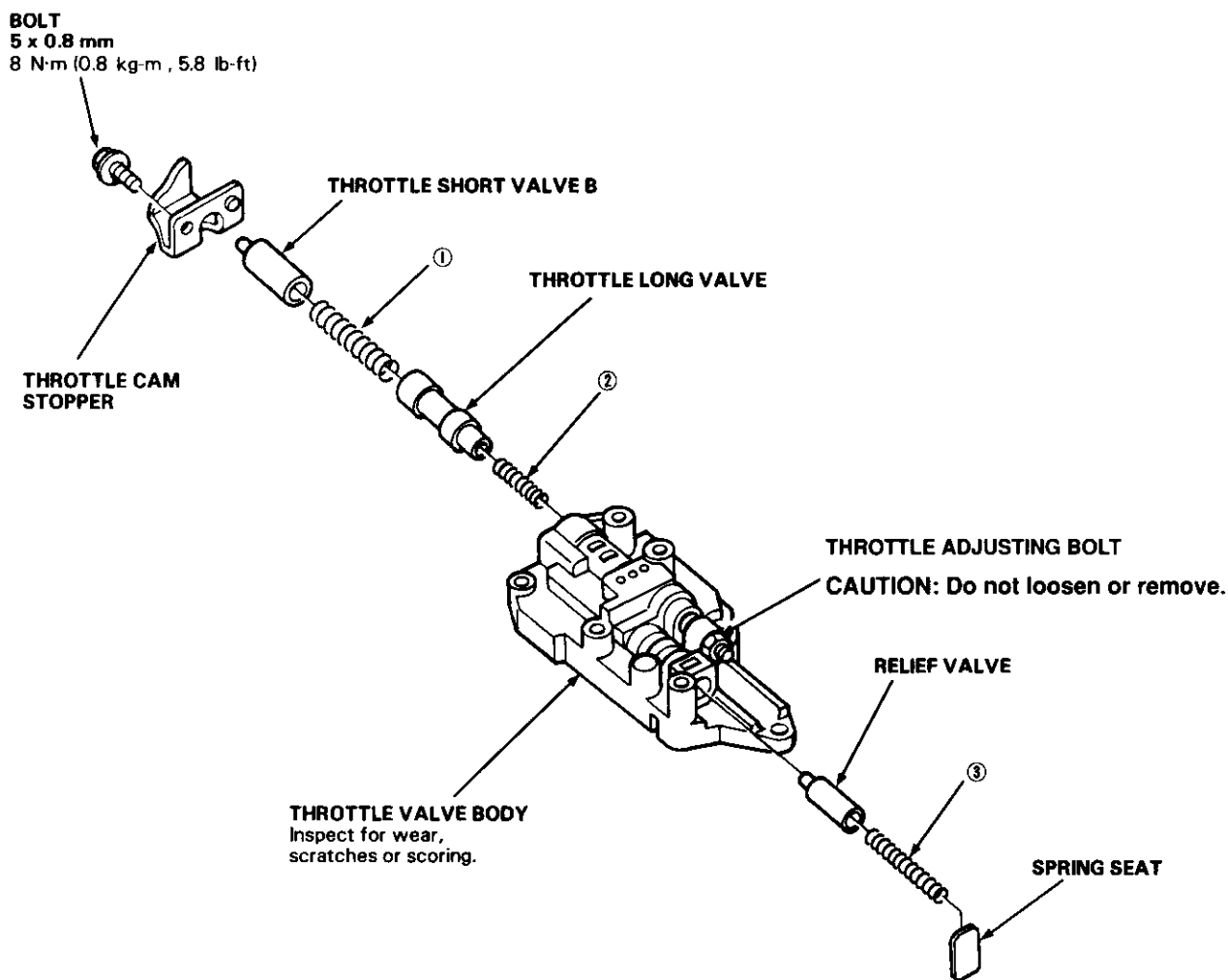

SPRING SPECIFICATIONS

Unit: mm (in)

No.	Springs	Standard (New)			
		Wire Dia.	O.D.	Free Length	No. of Coils
①	Throttle valve B spring	1.40 (0.055)	8.50 (0.335)	41.50 (1.634)	10.5
		1.40 (0.055)	8.50 (0.335)	41.50 (1.634)	11.2
		1.40 (0.055)	8.50 (0.335)	41.60 (1.638)	12.4
②	Throttle valve B adjusting spring	0.80 (0.031)	6.20 (0.244)	30.00 (1.181)	8.0
③	Relief valve spring	1.00 (0.039)	8.40 (0.331)	39.10 (1.539)	15.1

Servo Body

Disassembly/Inspection/Reassembly

NOTE:

- Clean all parts thoroughly in solvent or carburetor cleaner, and dry with compressed air. Blow out all passages.
- Replace the servo body as an assembly if any parts are worn or damaged.
- Replace ATF strainer if its inlet opening is clogged.
- Coat all parts with ATF before assembly.

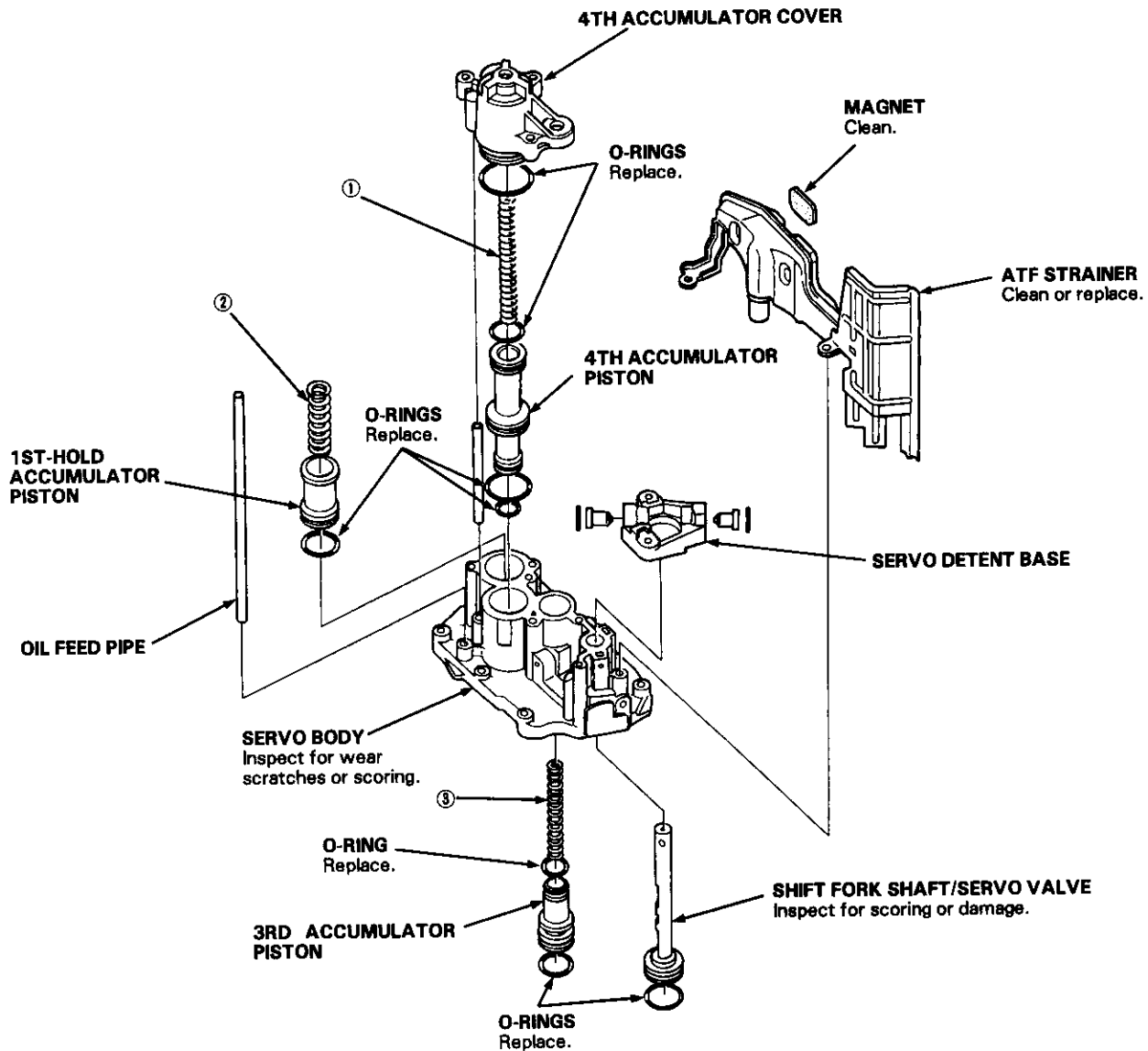

SPRING SPECIFICATIONS

Unit: mm (in)

No.	Springs	Standard (New)			
		Wire Dia.	O.D.	Free Length	No. of Coils
①	4th accumulator spring	2.90 (0.114)	22.00 (0.866)	90.10 (3.547)	10.9
②	1st-hold accumulator spring	4.00 (0.157)	25.00 (0.984)	64.70 (2.547)	7.3
③	3rd accumulator spring	2.60 (0.102)	17.50 (0.689)	104.50 (4.114)	18.0



1st/2nd Accumulator Body

Disassembly/Inspection/Reassembly

NOTE:

- Clean all parts thoroughly in solvent or carburetor cleaner, and dry with compressed air. Blow out all passages.
- Coat all parts with ATF before assembly.

CAUTION: Do not use a magnet to remove the check balls; it may magnetize the balls.

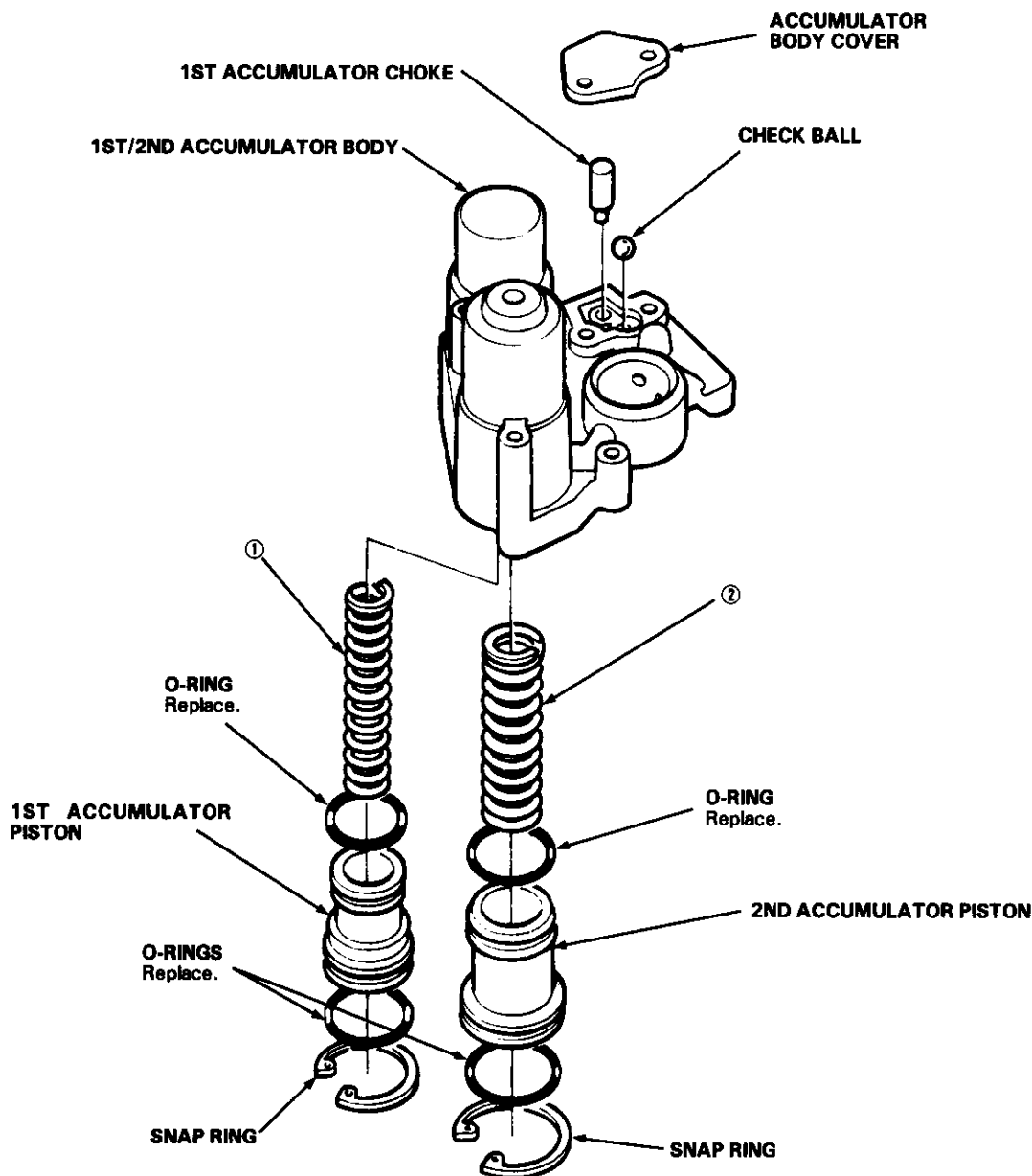

SPRING SPECIFICATIONS

Unit: mm (in)

No.	Springs	Standard (New)			
		Wire Dia.	O.D.	Free Length	No. of Coils
①	1st accumulator spring	1.80 (0.071)	16.30 (0.642)	115.40 (4.543)	18.6
②	2nd accumulator spring	3.30 (0.130)	22.00 (0.866)	84.90 (3.343)	11.1

Mainshaft

Disassembly/Inspection/Reassembly

NOTE:

- Lubricate all parts with ATF during reassembly.
- Install the thrust needle bearings with unrolled edge of bearing retainer facing washer.
- Inspect thrust needle and needle bearings for galling and rough movement.
- Before installing the O-rings, wrap the shaft splines with tape to prevent damage to the O-rings.

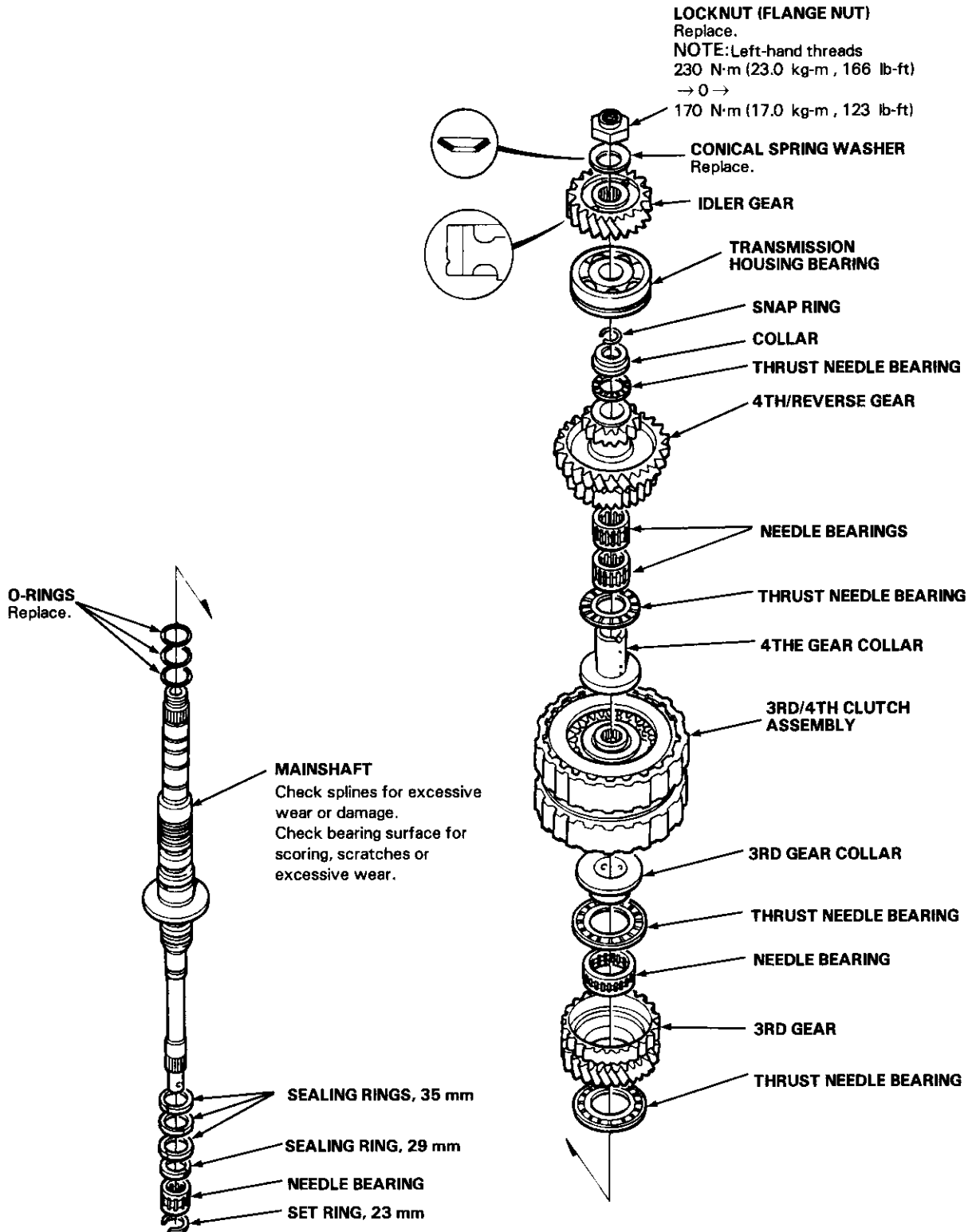



Countershaft

Disassembly/Inspection/Reassembly

NOTE:

- Lubricate all parts with ATF during reassembly.
- Install the thrust needle bearings with unrolled edge of bearing retainer facing washer.
- Inspect thrust needle and needle bearings for galling and rough movement.
- Before installing the O-rings, wrap the shaft splines with tape to prevent damage to the O-rings.

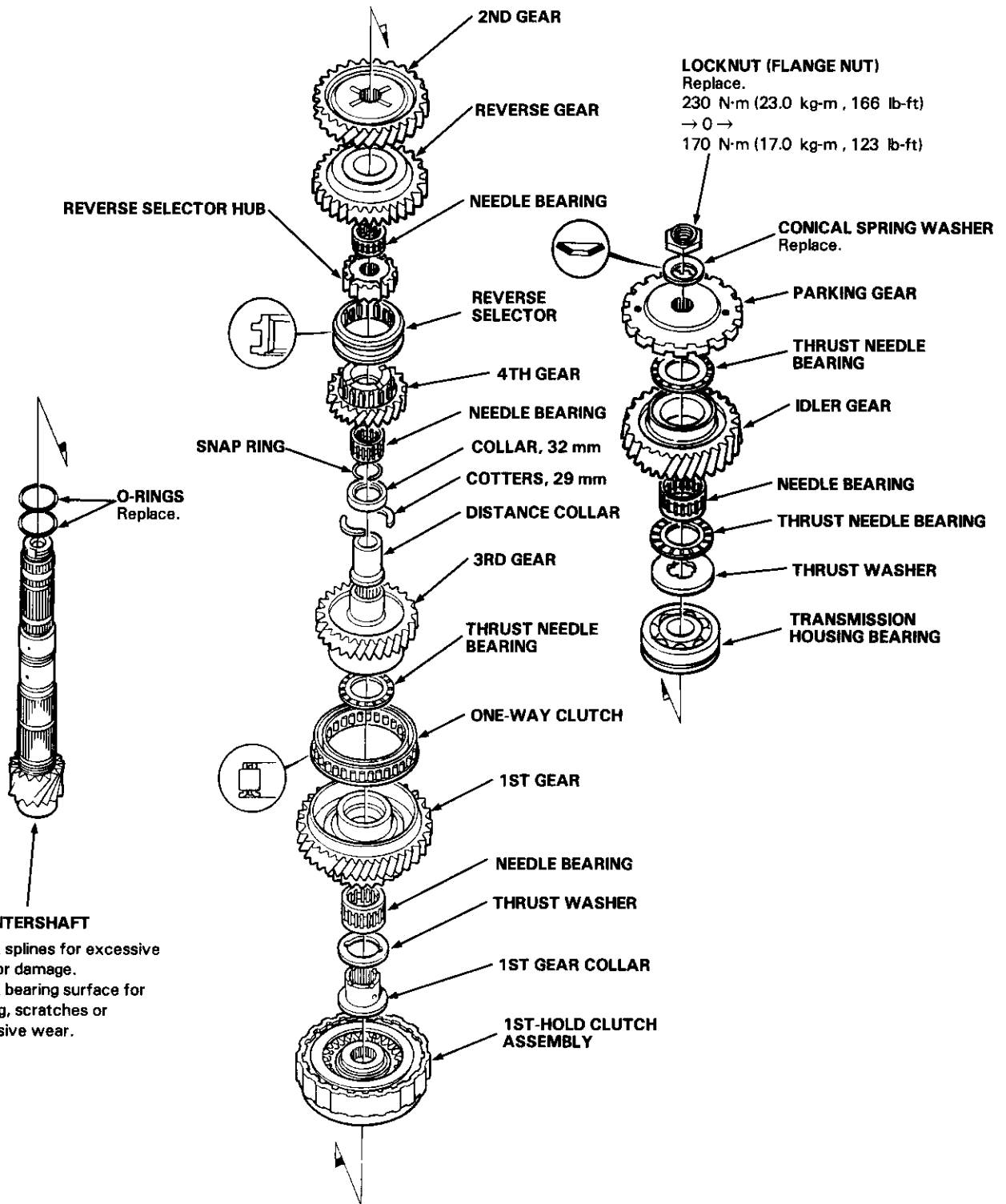

COUNTERSHAFT

Check splines for excessive wear or damage.
Check bearing surface for scoring, scratches or excessive wear.

Countershaft

Removal

1. Using a press, press out the countershaft while supporting the 1st-hold clutch.

NOTE:

Place an attachment between the press and countershaft to prevent damage to the shaft.

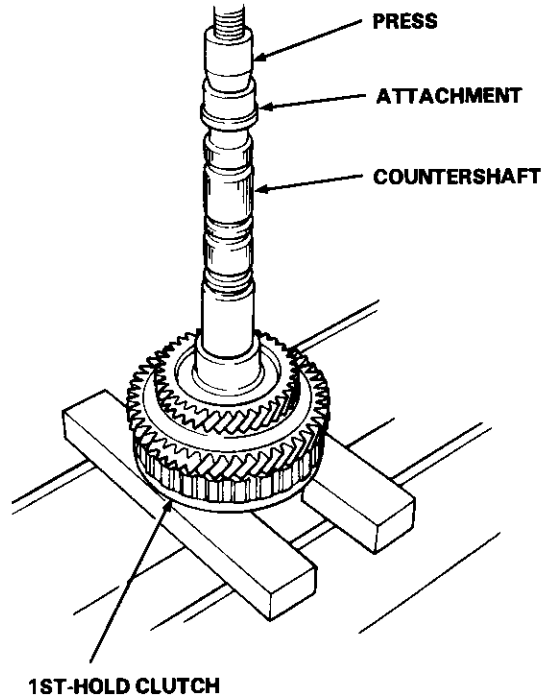



Installation

NOTE:

Lubricate all parts with ATF during assembly.

1. Install two new O-rings on the countershaft.

NOTE:

Before installing the O-rings, wrap the shaft splines with tape to prevent damage to the O-rings.

2. Assemble the 1st-hold clutch assembly, 1st gear collar, thrust washer, needle bearing, 1st gear, one-way clutch, thrust needle bearing and 3rd gear.

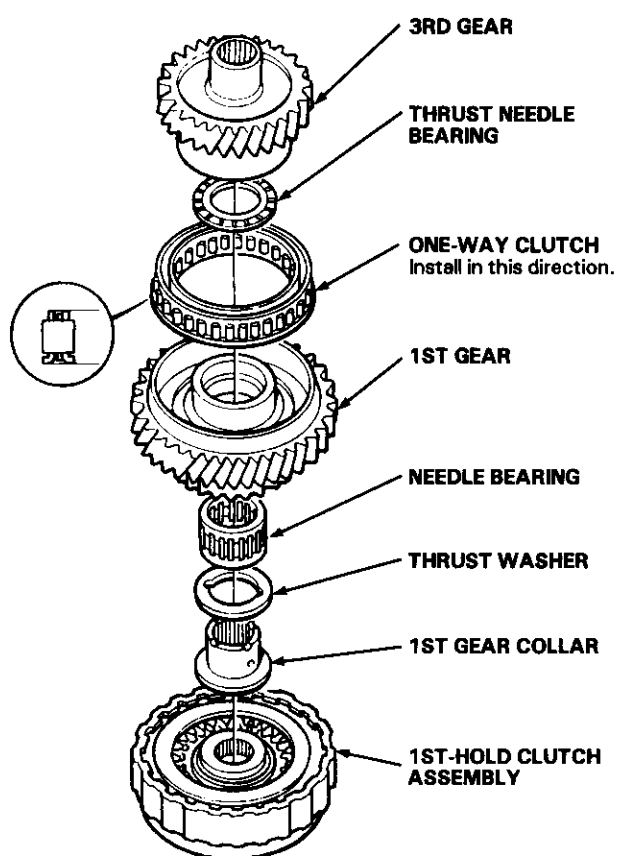

3. Install the above assembly on the countershaft.

4. Align the shaft splines with those of 3rd gear, then press the countershaft into 3rd gear with a press.

NOTE:

- Also align the shaft splines with those of the 1st-hold clutch when pressing the countershaft into the 3rd gear.
- Use an attachment between the shaft and a press to prevent damage to the countershaft.
- Stop pressing the countershaft when the 1st-hold clutch contacts the final drive gear.

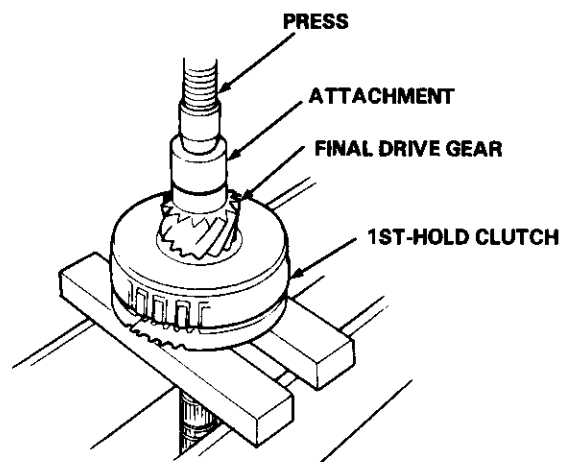

One-way Clutch

Disassembly/Inspection/Reassembly

1. Separate countershaft 3rd gear from countershaft 1st gear by turning 3rd gear in the direction shown.

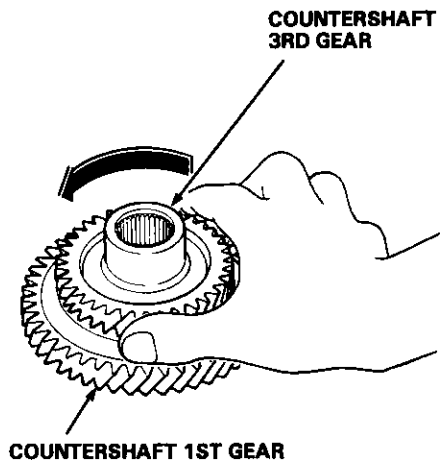

2. Remove the one-way clutch by prying it up with the end of a screwdriver.

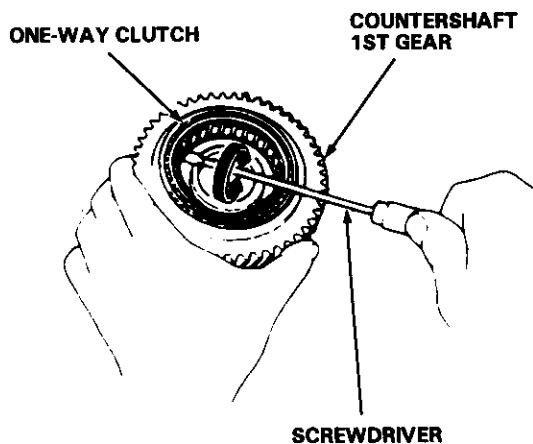

3. Inspect the parts as follows:

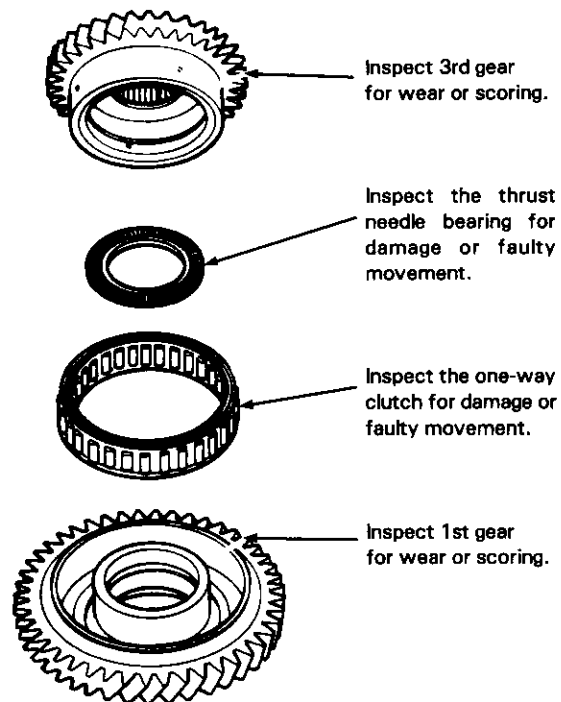

4. After the parts are assembled, hold countershaft 1st gear and turn countershaft 3rd gear in the direction shown to be sure it turns freely.

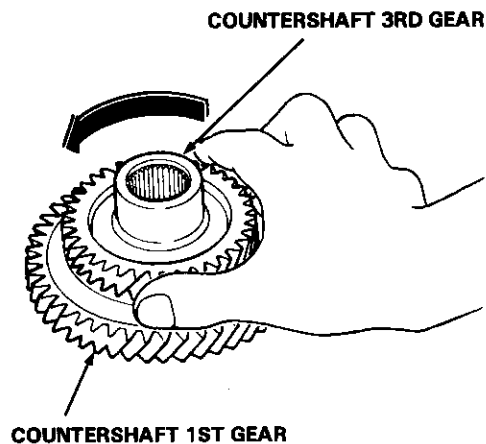



Secondary Shaft

Disassembly/Inspection/Reassembly

NOTE:

- Lubricate all parts with ATF during reassembly.
- Install the thrust needle bearings with unrolled edge of bearing retainer facing washer.
- Inspect thrust needle and needle bearings for galling and rough movement.
- Before installing the O-rings, wrap the shaft splines with tape to prevent damage to the O-rings.

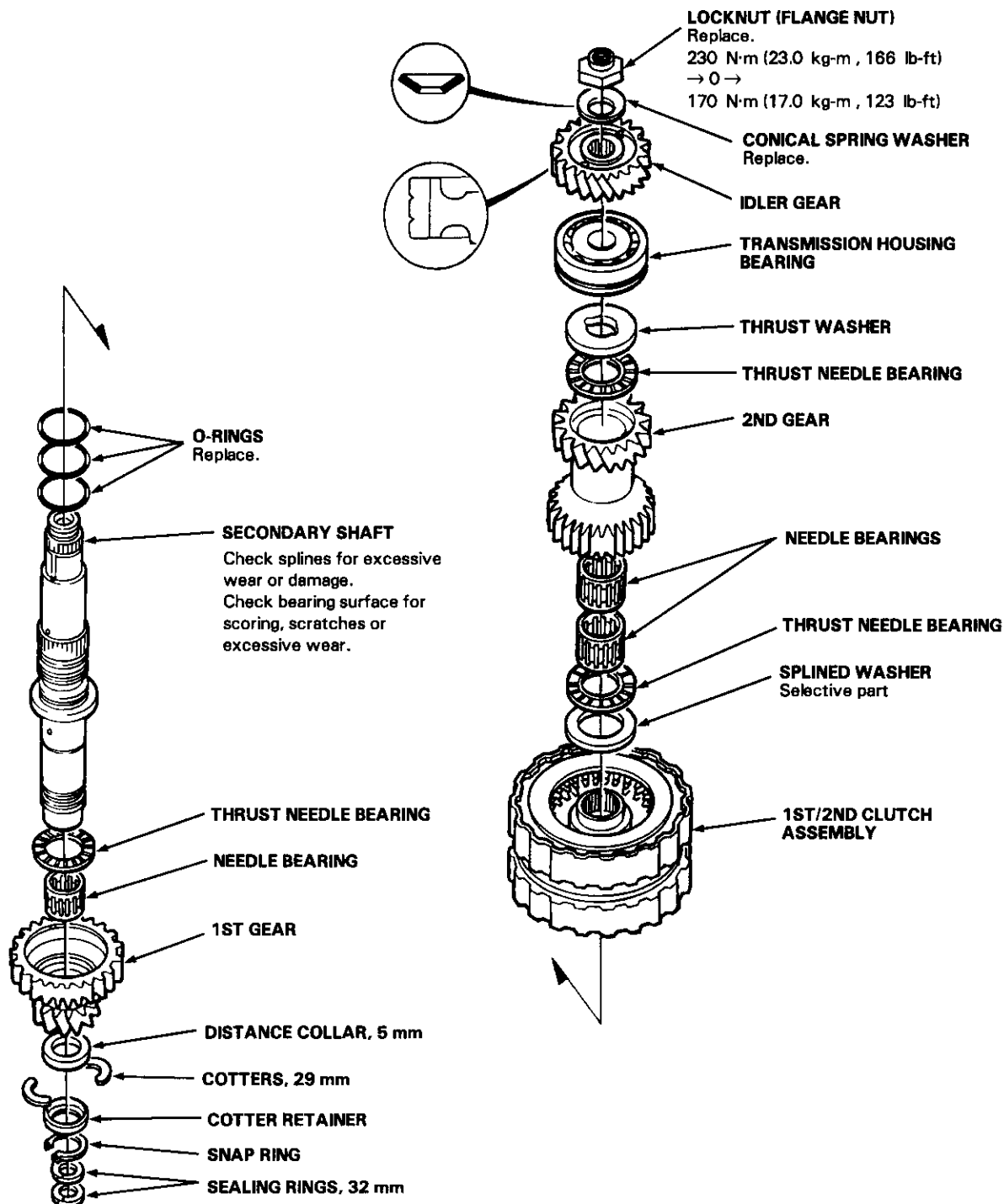

Secondary Shaft

Inspection

• Clearance Measurement

NOTE:

Lubricate all parts with ATF during assembly.

1. Remove the secondary shaft bearing from the transmission housing (see page 14-129).
2. Assemble the secondary shaft assembly without O-rings. Install the idler gear using a press, then torque the secondary shaft locknut to 30 N·m (3.0 kg·m, 22 lb-ft)

NOTE:

Do not install the O-rings during inspection.

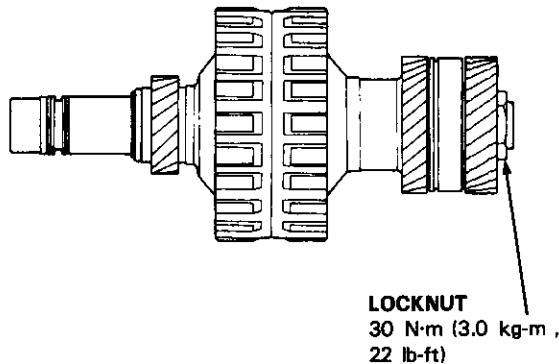

3. Attach the dial indicator to 2nd gear as shown.

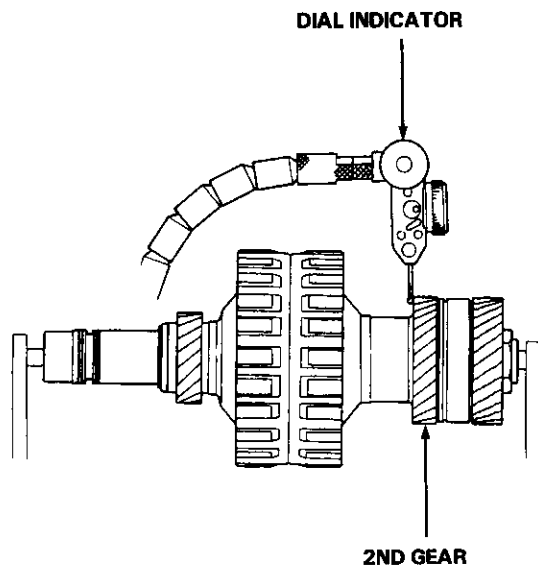

4. Measure 2nd gears axial clearance while moving 2nd gear.

STANDARD: 0.07—0.15 mm (0.003—0.006 in)

NOTE:

Take measurements in at least three places, and use the average as the actual clearance.

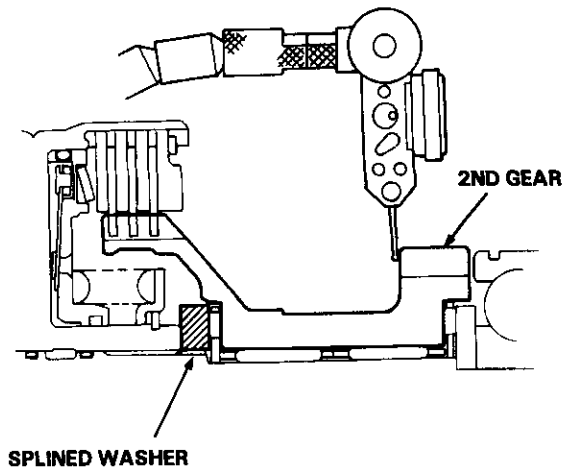

5. If the clearance is out of tolerance, remove the splined washer and measure the thickness.

SPLINED WASHER

No.	Part Number	Thickness
1	90406—PX4—700	4.05 mm (0.159 in)
2	90407—PX4—700	4.10 mm (0.161 in)
3	90408—PX4—700	4.15 mm (0.163 in)
4	90409—PX4—700	4.20 mm (0.165 in)
5	90410—PX4—700	4.25 mm (0.167 in)
6	90411—PX4—700	4.30 mm (0.169 in)
7	90412—PX4—700	4.35 mm (0.171 in)
8	90413—PX4—700	4.40 mm (0.173 in)
9	90414—PX4—700	4.45 mm (0.175 in)

6. After replacing the splined washer, make sure that the clearance is within tolerance.



Clutch

Illustrated Index

3RD/4TH CLUTCH ASSEMBLY

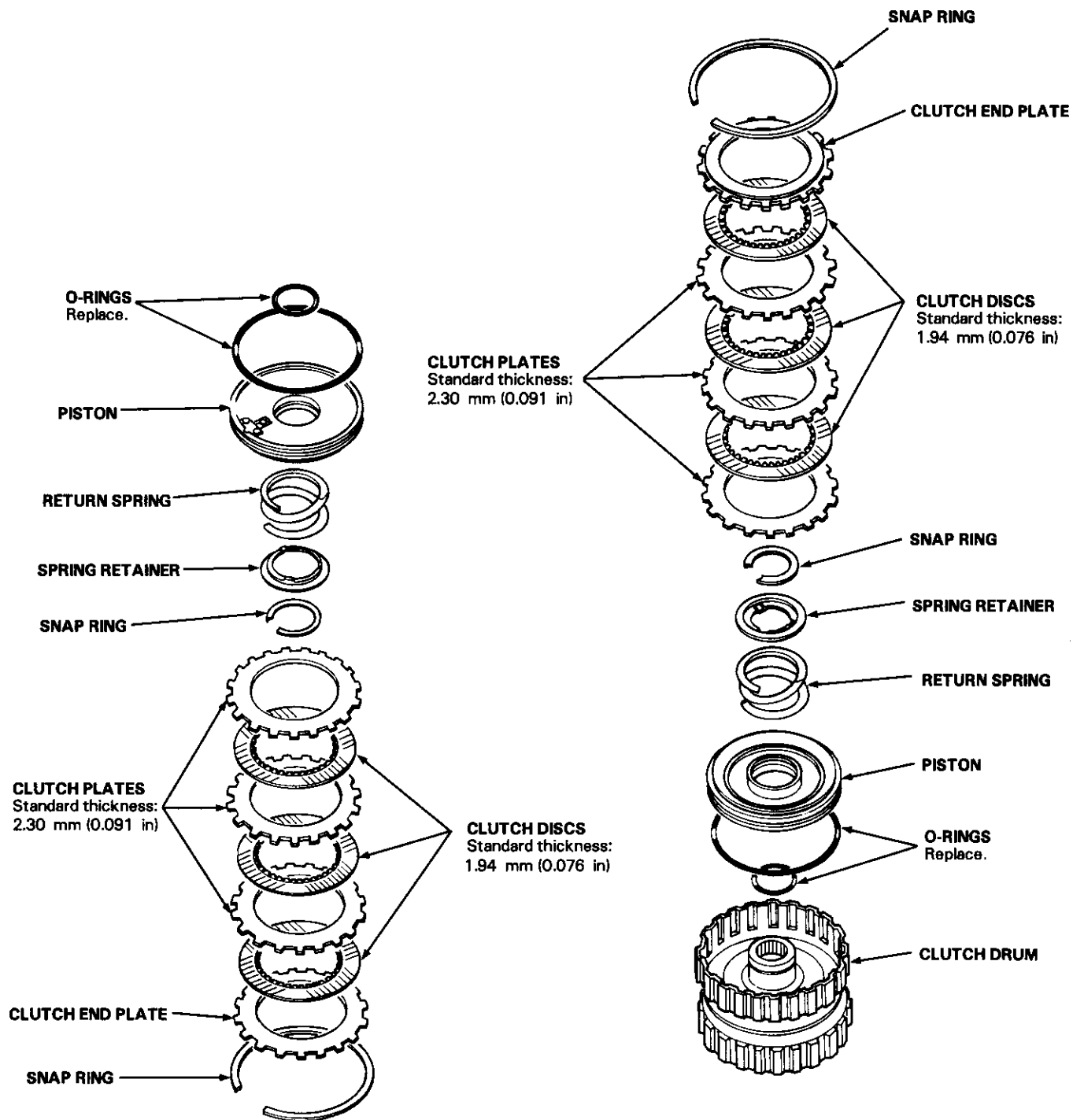

(cont'd)

Clutch

Illustrated Index (cont'd)

1ST/2ND CLUTCH ASSEMBLY: H23A1 Engine

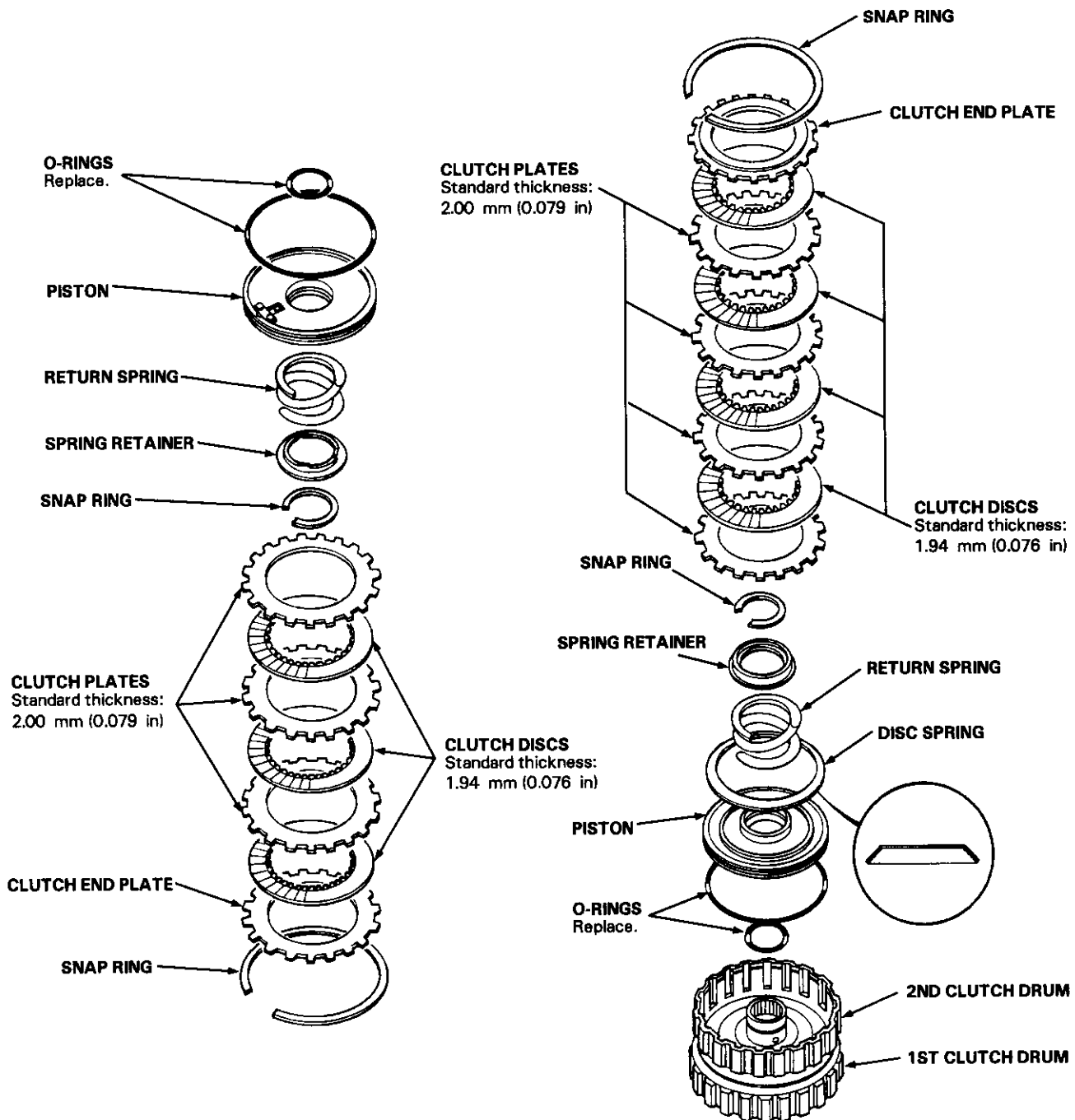



1ST/2ND CLUTCH ASSEMBLY: F22A1 Engine

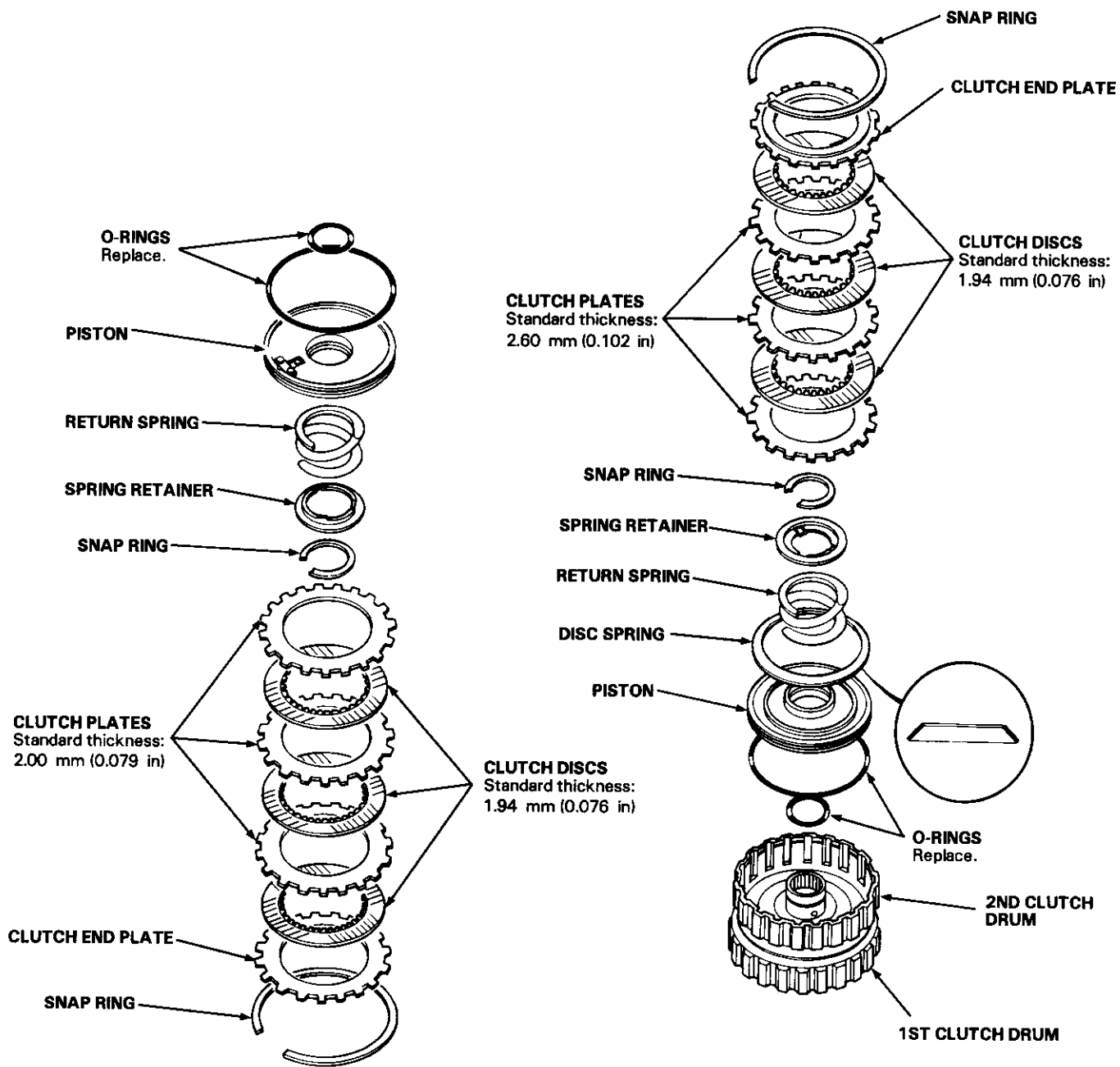

(cont'd)

Clutch

Illustrated Index (cont'd)

1ST-HOLD CLUTCH ASSEMBLY

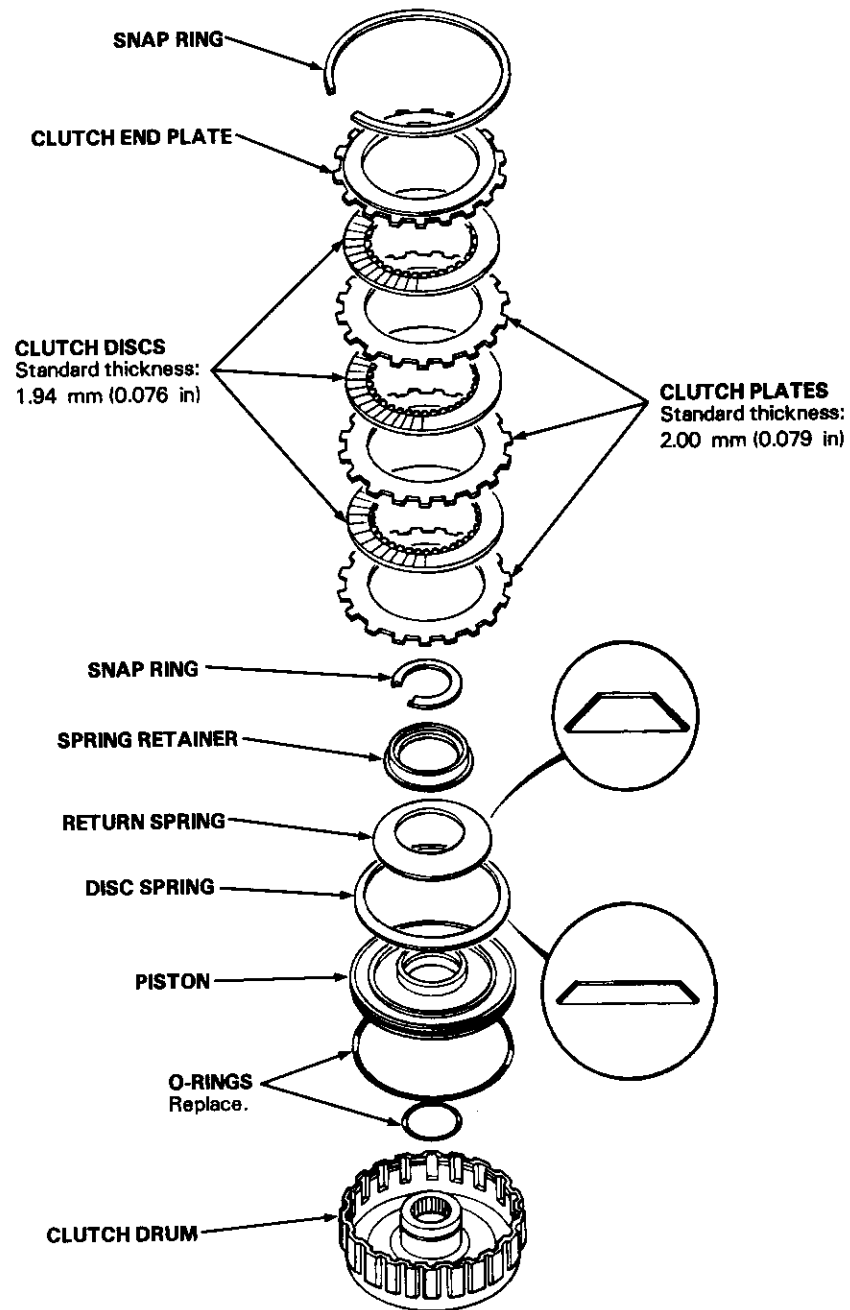



Disassembly

1. Remove the snap ring, then remove the clutch end plate, clutch discs and plates.

NOTE: For all clutches

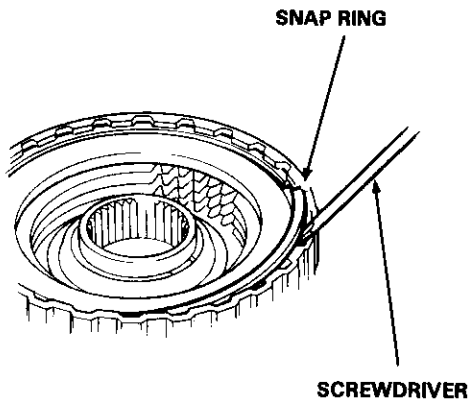

2. Remove the disc spring.

NOTE: For 1st-hold and 2nd clutches

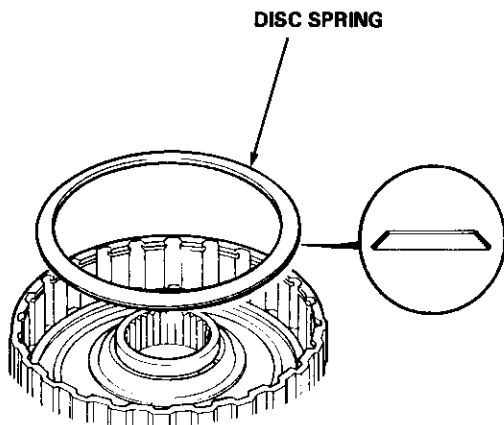

3. Install the special tools as shown.

NOTE: For 1st-hold clutch

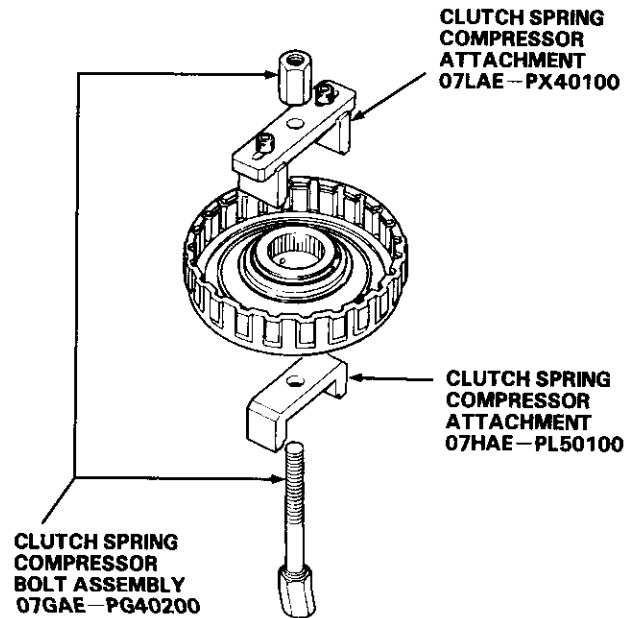

NOTE: For 1st, 2nd, 3rd and 4th clutches.

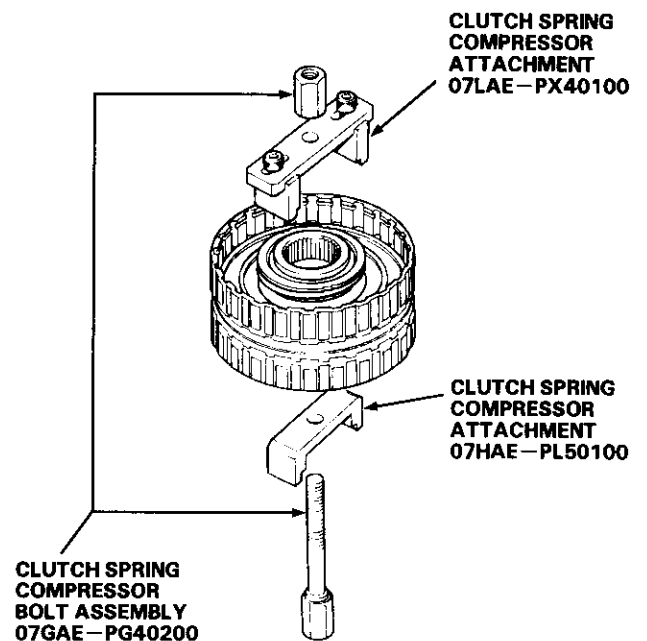

(cont'd)

Clutch

Disassembly (cont'd)

CAUTION:

If either end of the compressor attachment is set over an area of the spring retainer which is unsupported by the return spring, the retainer may be damaged.

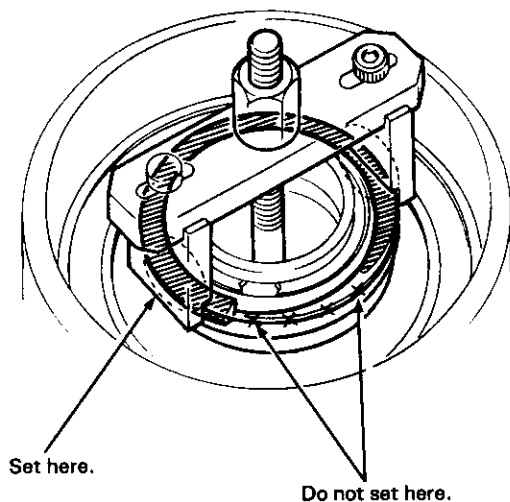

NOTE: Steps 4 thru 6 are for all clutches.

4. Compress the return spring.

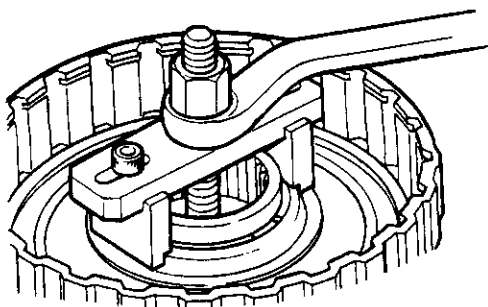

5. Remove the snap ring. Then remove the special tools, spring retainer and return spring.

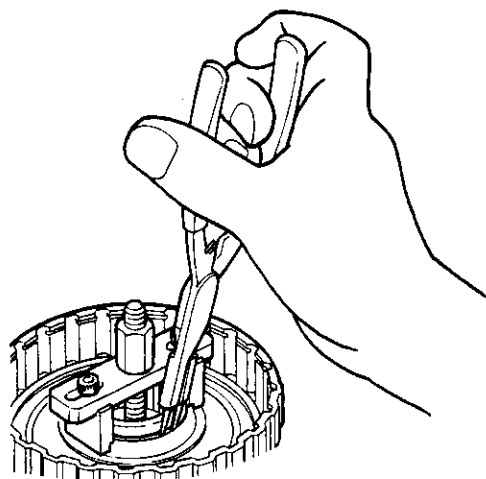

6. Wrap a shop rag around the clutch drum and apply air pressure to the oil passage to remove the piston. Place a finger tip on the other end while applying air pressure.

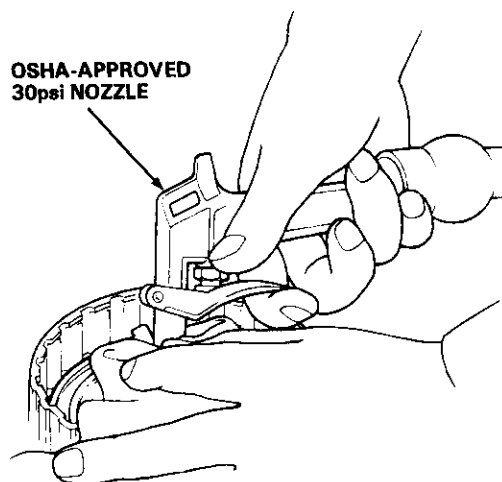



Reassembly

NOTE:

- Clean all parts thoroughly in solvent or carburetor cleaner, and dry with compressed air.
- Blow out all passages.
- Lubricate all parts with ATF before assembly.

1. Inspect the piston for a loose check valve, if the check valve is loose, replace the piston.

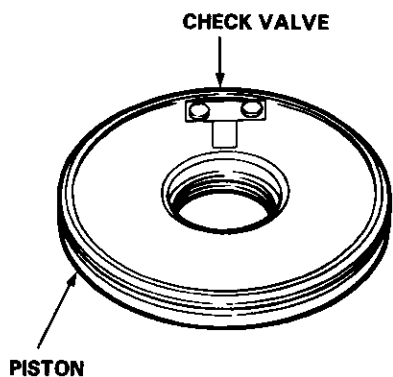

2. Be sure that the disc spring is securely staked.

NOTE:

For 1st, 3rd and 4th clutches

3. Install new O-rings on the piston.

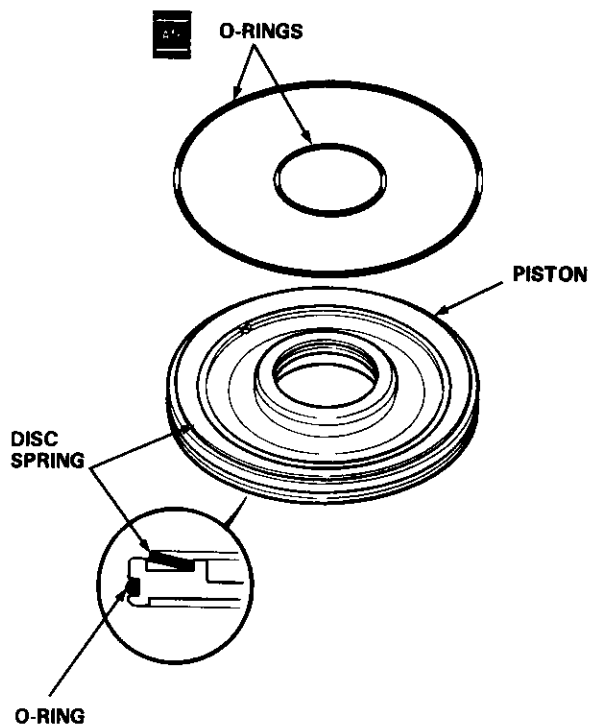

4. Install the piston in the clutch drum. Apply pressure and rotate to ensure proper seating.

NOTE:

- For all clutches
- Lubricate the piston O-ring with ATF before installing.

CAUTION:

Do not pinch O-ring by installing the piston with force.

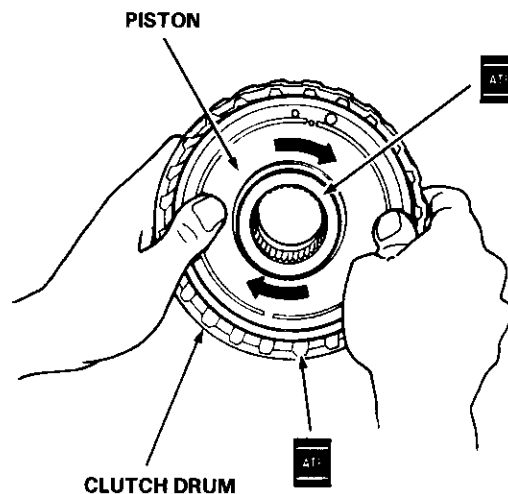

5. Install the return spring and spring retainer and position the snap ring on the retainer.

NOTE: For all clutches

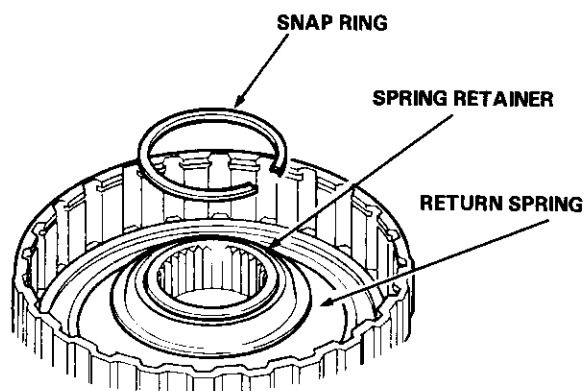

(cont'd)

Clutch

Reassembly (cont'd)

6. Install the special tools as shown.

NOTE: For 1st-hold clutch

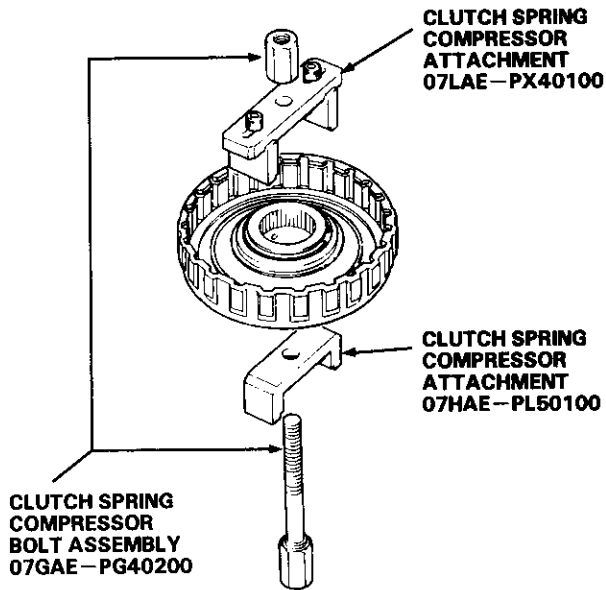

NOTE: For 1st, 2nd, 3rd and 4th clutches

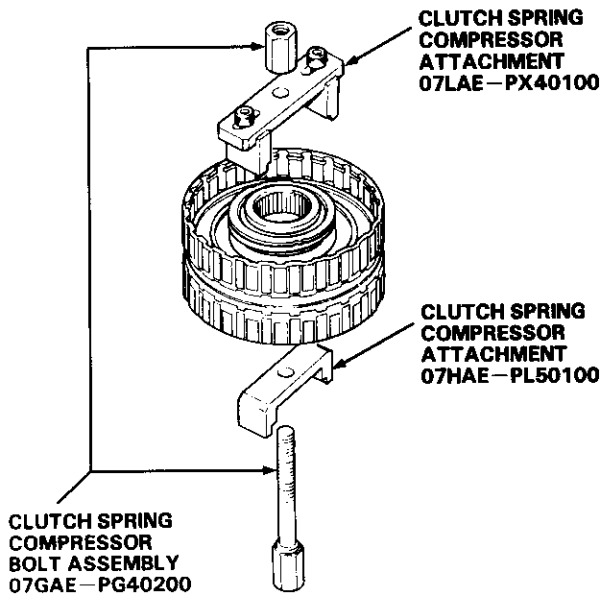

CAUTION:

If either end of the compressor attachment is set over an area of the spring retainer which is unsupported by the return spring, the retainer may be damaged.

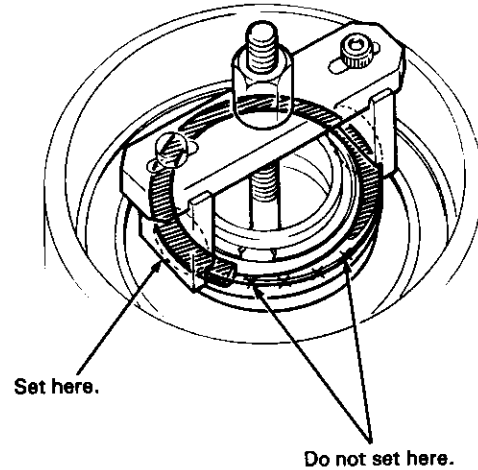

NOTE: Steps 7 thru 9 are for all clutches.

7. Compress the return spring.

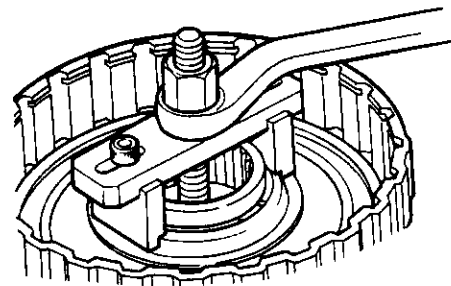



8. Install the snap ring.

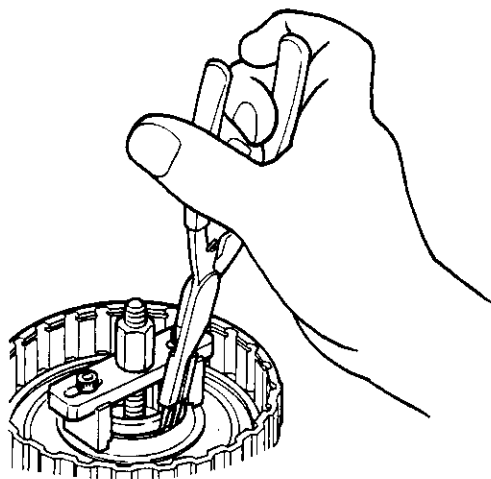

9. Remove the special tools.

10. Install the disc spring.

NOTE:

- For 1st-hold and 2nd clutches
- Install the disc spring in the direction shown.

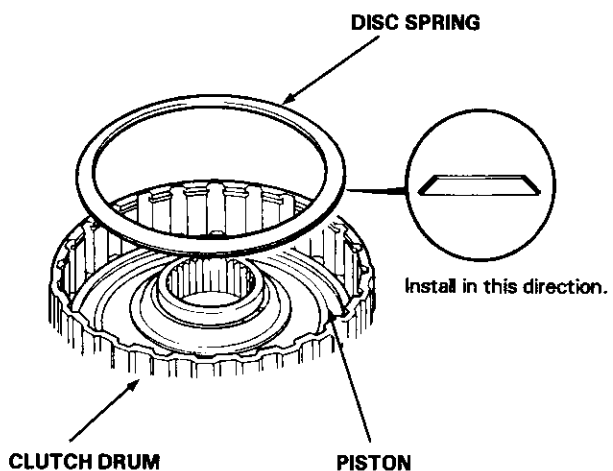

NOTE: Steps 11 thru 15 are for all clutches.

11. Soak the clutch discs thoroughly in ATF for a minimum of 30 minutes.
12. Starting with a clutch plate, alternately install the clutch plates and discs. Install the clutch end plate with flat side toward the disc.

NOTE:

Before installing the plates and discs, make sure the inside of the clutch drum is free of dirt or other foreign matter.

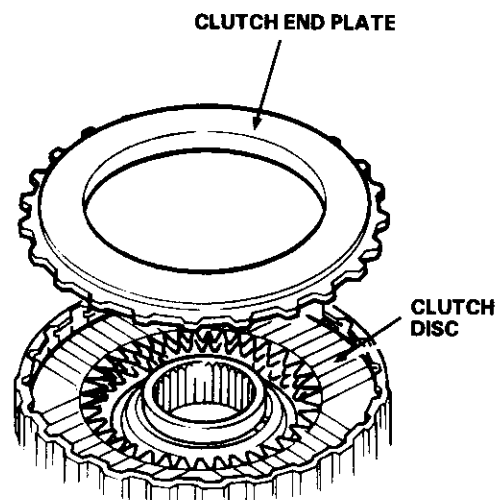

13. Install the snap ring.

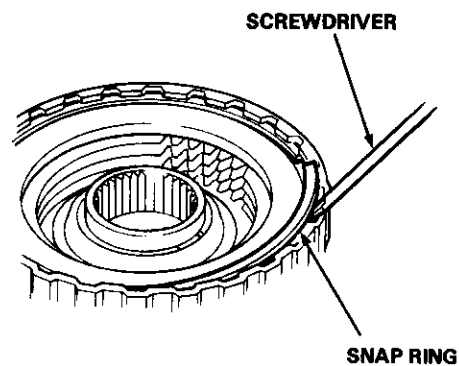

(cont'd)

Clutch

Reassembly (cont'd)

14. Measure the clearance between the clutch end plate and top disc with a dial indicator. Zero the dial indicator with the clutch end plate lowered and lift it up to the snap ring. The distance that the clutch end plate moves is the clearance between the clutch end plate and top disc.

NOTE:
Measure at three locations.

Clutch End Plate-to-Top Disc Clearance:

Clutch	Service Limit
1st	0.65—0.85 mm (0.026—0.033 in)
2nd	0.65—0.85 mm (0.026—0.033 in)
3rd	0.40—0.60 mm (0.016—0.024 in)
4th	0.40—0.60 mm (0.016—0.024 in)
1st-Hold	0.80—1.00 mm (0.031—0.039 in)

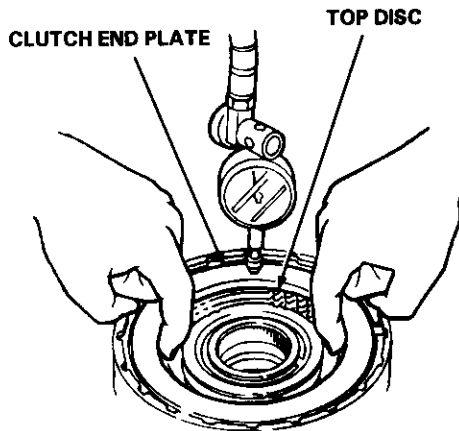

15. If the clearance is not within the service limits, select a new clutch end plate from the following table.

NOTE:

If the thickest clutch end plate is installed but the clearance is still over the standard, replace the clutch discs and clutch plates.

CLUTCH END PLATE

Plate No.	Part Number	Thickness mm (in)
1	22551-PX4-003	2.10 (0.083)
2	22552-PX4-003	2.20 (0.087)
3	22553-PX4-003	2.30 (0.091)
4	22554-PX4-003	2.40 (0.094)
5	22555-PX4-003	2.50 (0.098)
6	22556-PX4-003	2.60 (0.102)
7	22557-PX4-003	2.70 (0.106)
8	22558-PX4-003	2.80 (0.110)
9	22559-PX4-003	2.90 (0.114)

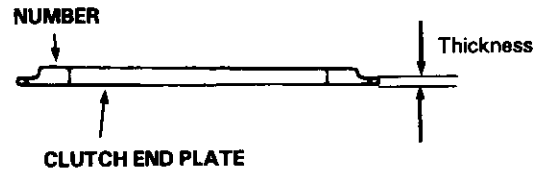



Torque Converter Housing Bearings

Mainshaft Bearing/Oil Seal Replacement

1. Drive out the mainshaft bearing and oil seal, using the special tools as shown.

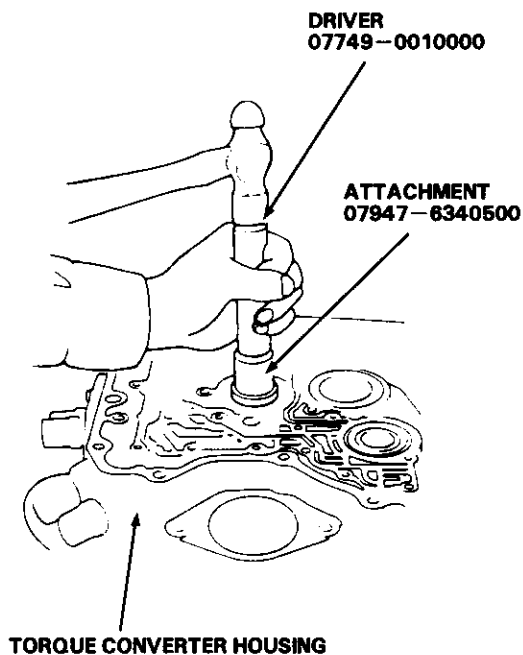

2. Drive in the new mainshaft bearing until it bottoms in the housing, using the special tools as shown.

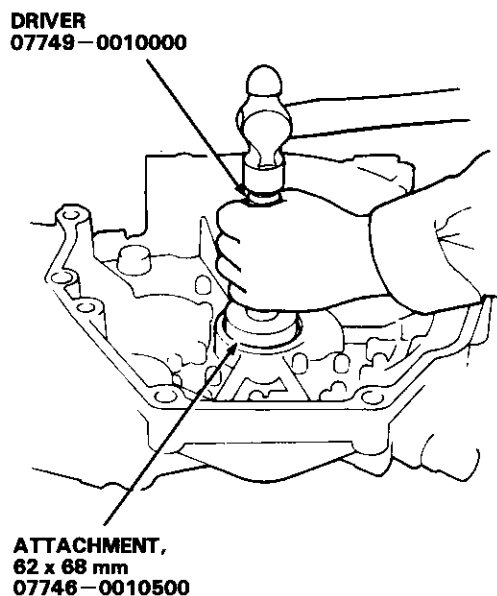

3. Install the new oil seal flush with the housing, using the special tools as shown.

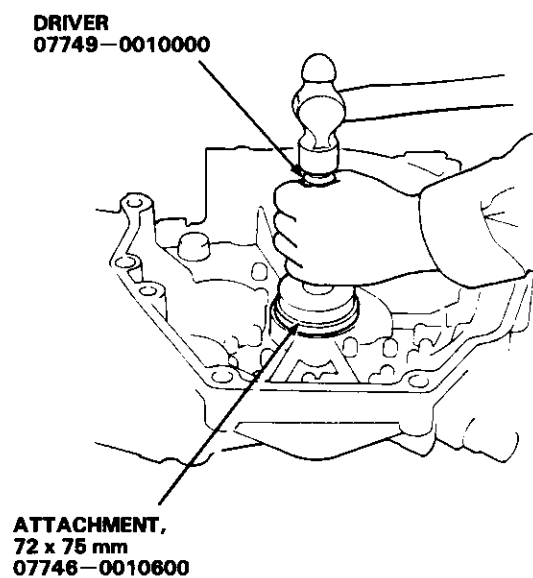

Torque Converter Housing Bearings

Countershaft Bearing Replacement

1. Remove the countershaft bearing using the special tool as shown.

Commercially Available
3/8 in. x 16 threads/in.
slide hammer

ADJUSTABLE BEARING PULLER, 25-40 mm
07736-A01000A

COUNTERSHAFT NEEDLE BEARING

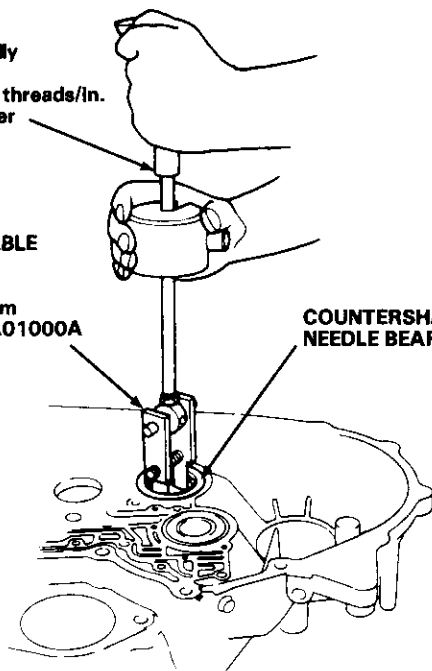

2. Install the oil guide plate.
3. Drive the new bearing into the housing, using the special tools as shown.

DRIVER
07749-0010000

ATTACHMENT,
62 x 68 mm
07746-0010500

BEARING

0-0.03 mm
(0-0.01 in)

HOUSING

OIL GUIDE PLATE

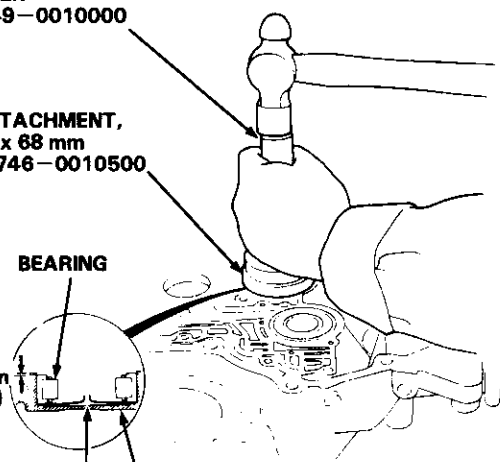

Secondary Shaft Bearing Replacement

1. Remove the secondary shaft bearing by heating the torque converter housing to 212°F (100°C) with a heat gun, then tap the housing until the bearing falls out.

CAUTION:

Do not heat the case in excess of 212°F (100°C).

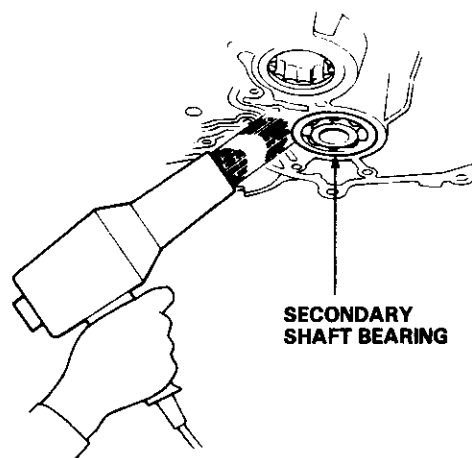

SECONDARY SHAFT BEARING

2. Install the oil guide plate.
3. Drive the new bearing into the housing, using the special tools as shown.

DRIVER
07749-0010000

ATTACHMENT,
52 x 55 mm
07746-0010400

BEARING

0-0.03 mm
(0-0.01 in)

HOUSING

OIL GUIDE PLATE

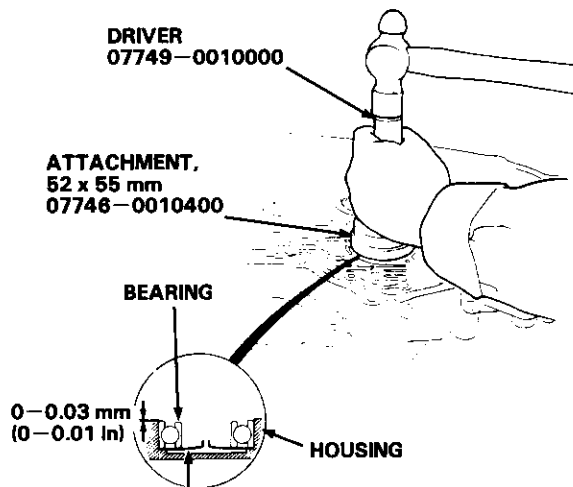



Transmission Housing Bearings

Removal/Installation

1. To remove the mainshaft, countershaft and secondary shaft bearings from the transmission housing, expand each snap ring with snap ring pliers, then push the bearing out.

NOTE:

Do not remove the snap rings unless it's necessary to clean the grooves in the housing.



Remove

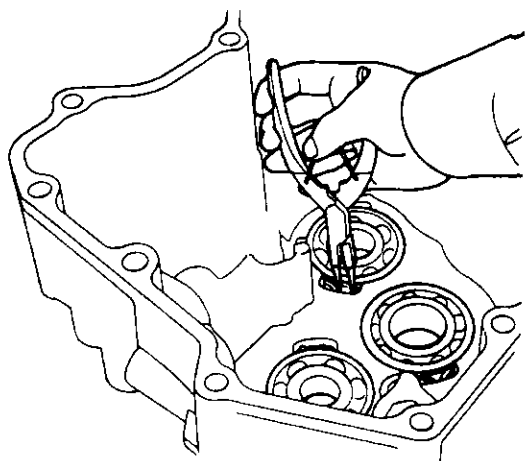

2. Expand each snap ring with snap ring pliers, insert the new bearing part-way into it, then release the pliers. Push the bearing down into the transmission until the ring snaps in place around it.

NOTE:

Install with groove side of the housing facing inside the transmission housing.

Install

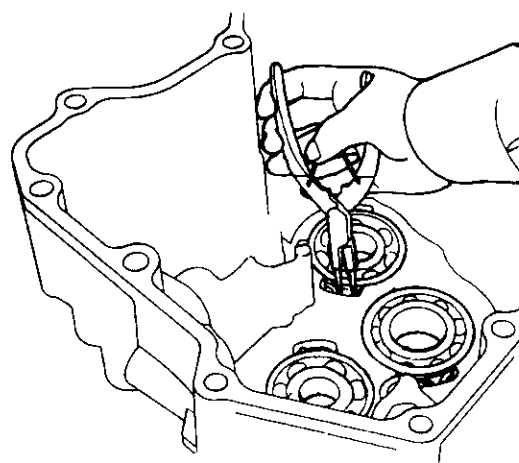
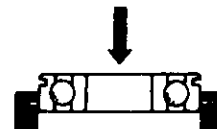

3. After installing the bearing verify the following:

- The snap ring is seated in the bearing and housing grooves.
- The snap ring operates properly.
- The ring end gap is correct.

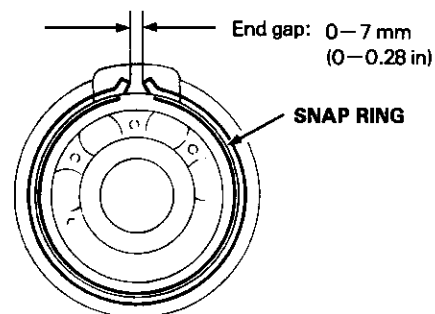

Transmission

Reassembly

NOTE:

- Coat all parts with ATF.
- Replace the parts below:
 - O-rings
 - Lock washers
 - Gaskets
 - Locknuts and conical spring washers
 - Sealing washer
- Torque the 6 x 1.0 mm Bolts:
12 N·m (1.2 kg·m , 9 lb-ft)

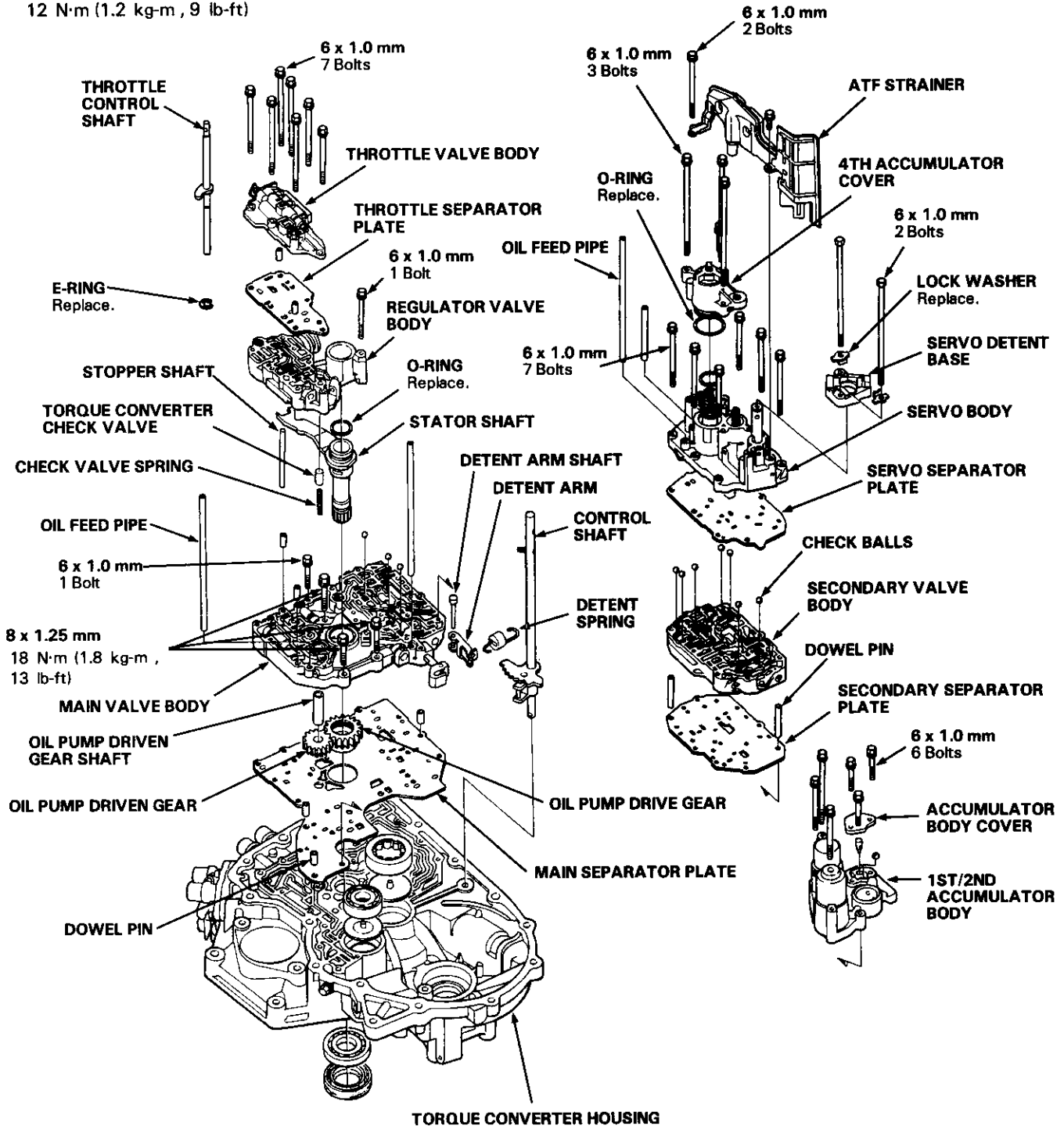



1. Install the main separator plate with three dowel pins on the torque converter housing. Then install the oil pump gears and oil pump driven gear shaft.

NOTE:

Install the oil pump driven gear with its grooved and chamfered side facing down.

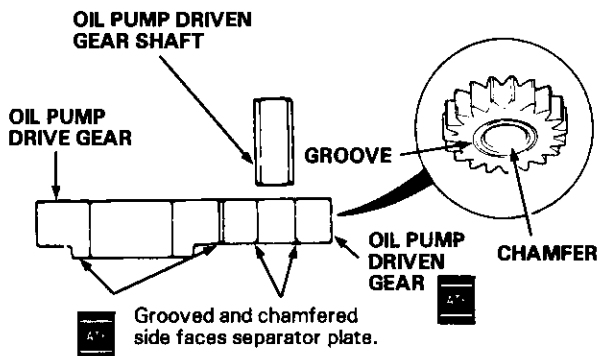

2. Install the main valve body with four bolts. Make sure the oil pump drive gear rotates smoothly in the normal operating direction and oil pump driven gear shaft moves smoothly in the axial and normal operating directions.
3. If the oil pump drive gear and oil pump driven gear shaft do not move freely, loosen the main valve body bolts, realign the oil pump driven gear shaft, and then retighten to the specified torque.

CAUTION:

Failure to align the oil pump driven gear shaft correctly will result in a seized oil pump drive gear or oil pump driven gear shaft.

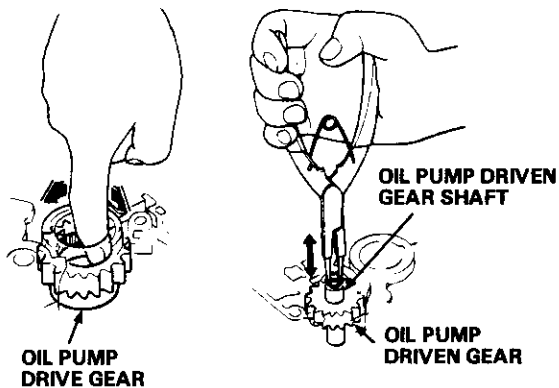

4. Install the stator shaft and stopper shaft.
5. Install the two dowel pins, torque converter check valve and torque converter check valve spring in the main valve body.
6. Install the regulator valve body with the bolt on the main valve body.
7. Install the two dowel pins and separator plate on the regulator valve body, then install the throttle valve body with seven bolts.

8. Install the secondary separator plate with two dowel pins on the main valve body.
9. Install the control shaft in the housing with the control shaft and manual valve together.
10. Install the detent arm and arm shaft in the main valve body, then hook the detent spring to the detent arm.

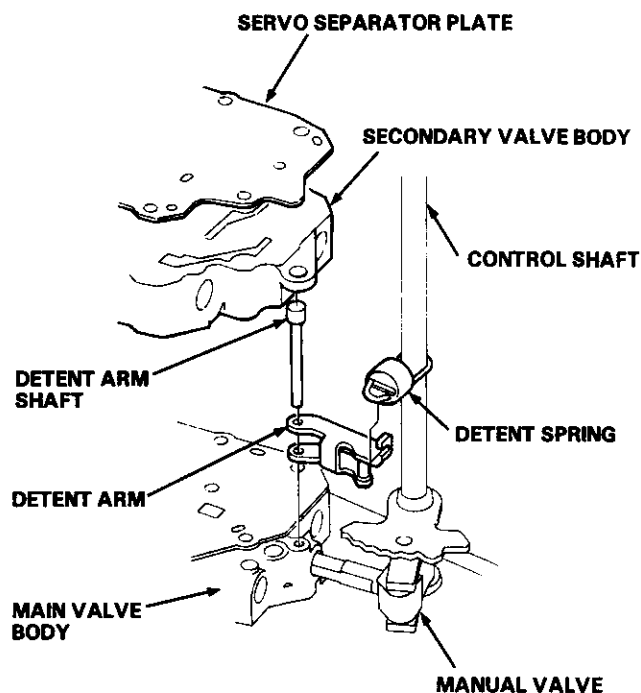

11. Install the secondary valve body, servo separator plate and servo body with seven bolts.
12. Install the oil feed pipe in the servo body, then install the 4th accumulator cover with three bolts.
13. Install the ATF strainer with two bolts.
14. Install the servo detent base with two bolts and new lock washers.
15. Install the 1st/2nd accumulator body with six bolts.
16. Install two oil feed pipes in the main valve body and the pipe in the servo body.

(cont'd)

Transmission

Reassembly (cont'd)

17. Install the differential assembly, countershaft sub-assembly, mainshaft sub-assembly, and secondary shaft sub-assembly in the torque converter housing.

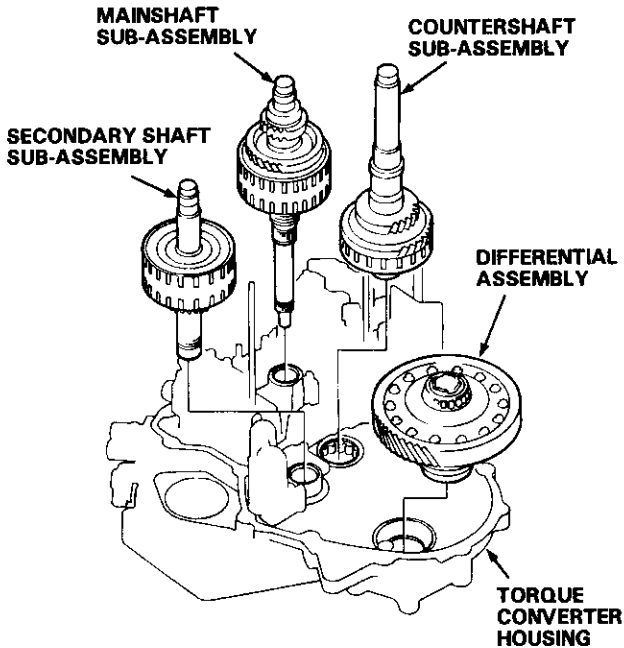

18. Install the splined washer, thrust needle bearing and needle bearings on the secondary shaft.
19. Install the needle bearings, countershaft 4th gear, reverse selector hub, and reverse selector with the shift fork on the countershaft.

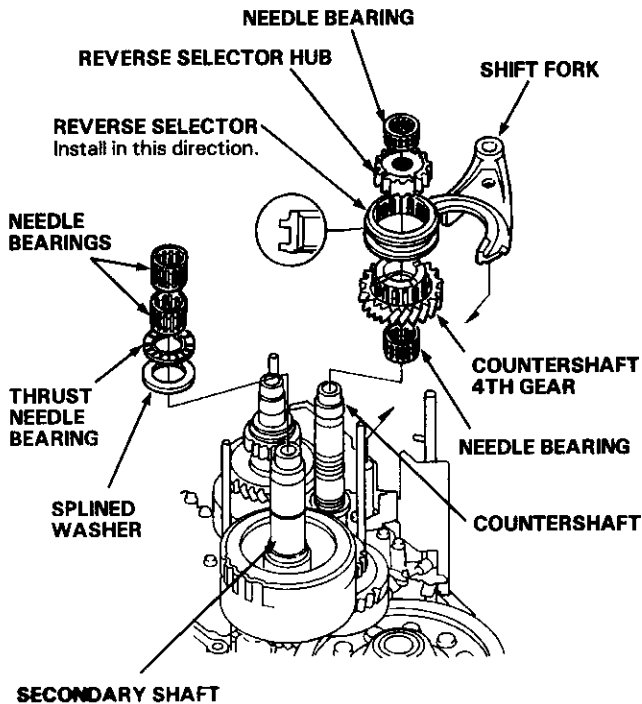

20. Turn the shift fork shaft so the large chamfered hole is facing the fork bolt hole. Then install the shift fork and the lock bolt with a new lock washer, and torque. Bend the lock tab against the bolt head.

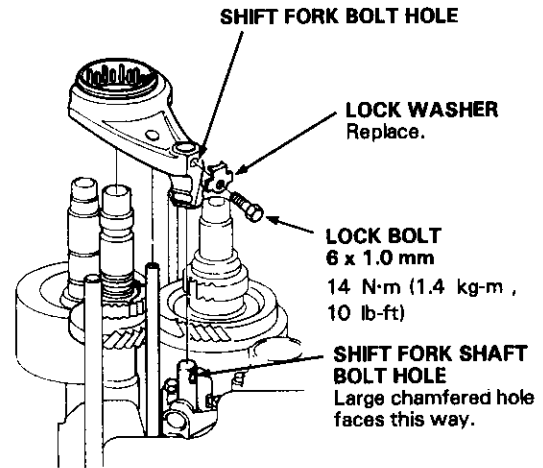

21. Install the secondary shaft 2nd gear, thrust needle bearing and thrust washer on the secondary shaft. Install the countershaft reverse gear and 2nd gear on the countershaft as shown.

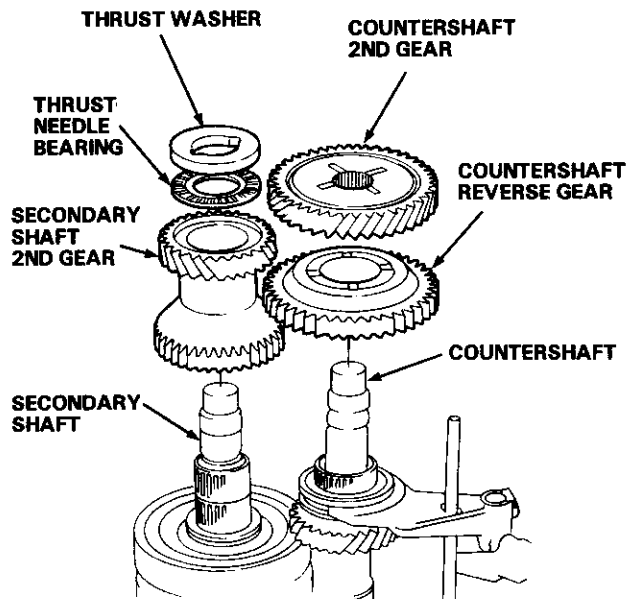



22. Slip the reverse idler gear into the transmission housing as shown.

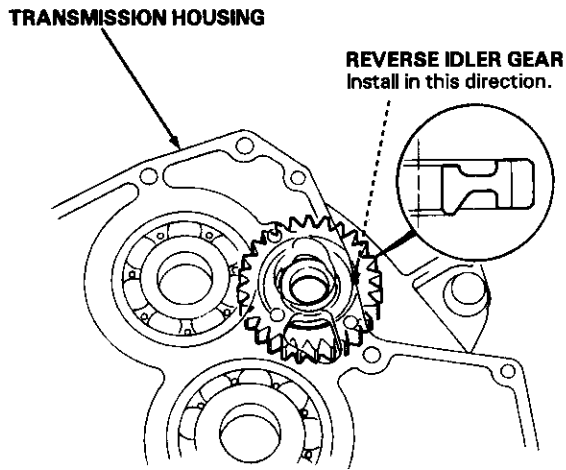

23. Align the spring pin of the control shaft with the transmission housing groove by turning the control shaft.
24. Install three dowel pins and a new gasket on the torque converter housing.
25. Place the transmission housing on the torque converter housing.

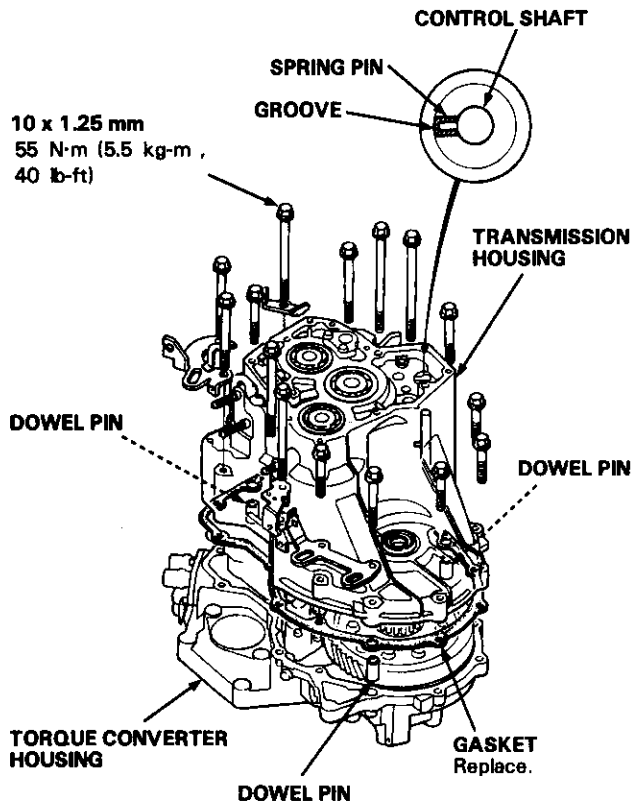

26. Install the transmission housing bolts and transmission hanger, then torque the bolts to 55 N·m (5.5 kg·m, 40 lb-ft) in two or more steps in the pattern shown.

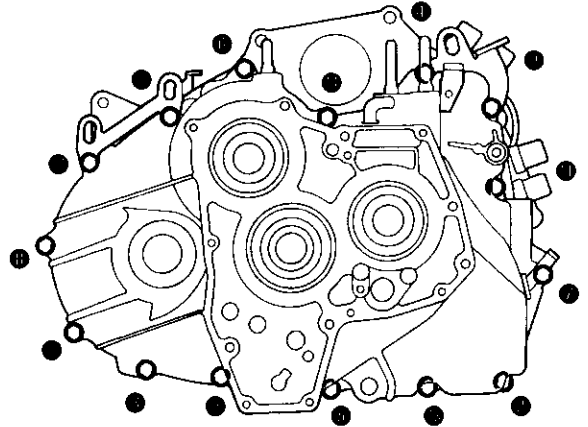

27. Engage the reverse idler gear to the countershaft and mainshaft reverse gears, then install the reverse idler gear shaft holder on the transmission housing.

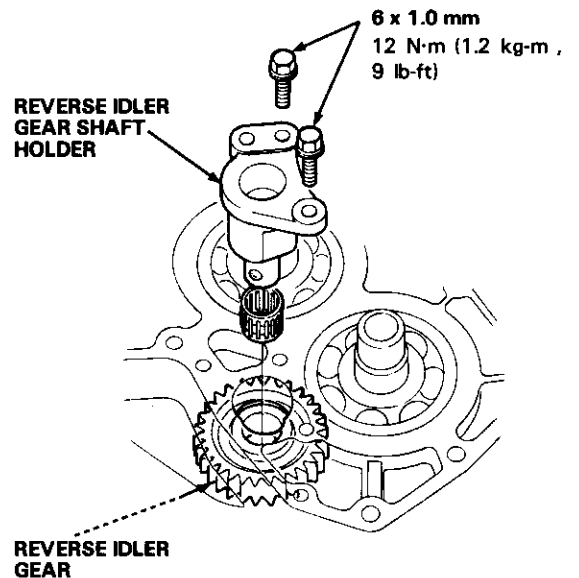

28. Install the parking brake lever on the control shaft, then torque the lock bolt loosely with a new lock washer.

NOTE:

Do not tighten the lock bolt to the specified torque and bend the lock tab in this step.

(cont'd)

Transmission

Reassembly (cont'd)

29. Slip the special tool onto the mainshaft.

MAINSHAFT HOLDER
07GAB—PF50100 or
07GAB—PF50101

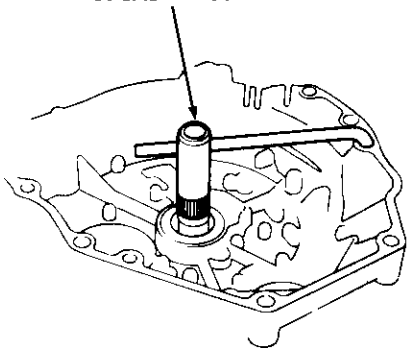

30. Install the mainshaft idler gear.

31. Install the old locknut on the mainshaft to seat the idler gear.

NOTE:

- The mainshaft locknut has left-hand threads.
- Do not drive the idler gear on with a hammer.

TORQUE: 230 N·m (23.0 kg·m , 166 lb-ft)

32. Install the secondary shaft idler gear on the secondary shaft.

33. Install the thrust washer, thrust needle bearing, needle bearing, countershaft idler gear and parking gear on the countershaft.

34. Install the old locknut on the secondary shaft. Tighten the old locknut to seat the secondary shaft idler gear while holding the countershaft idler gear.

NOTE:

Do not drive the idler gear on with a hammer.

TORQUE: 230 N·m (23.0 kg·m , 166 lb-ft)

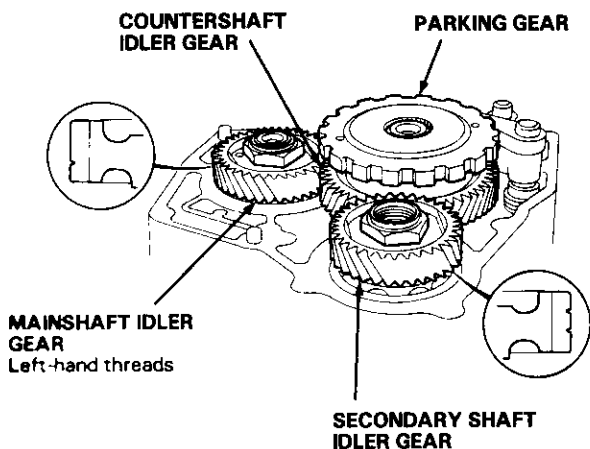

35. Place a 24 mm socket on the parking gear, and install a 10 x 1.25 mm bolt in the countershaft. Then engage the parking brake pawl with the parking gear by moving up the parking brake pawl.

CAUTION:

Keep all of the particles out of the transmission when installing a bolt.

36. Tighten the bolt and lightly seat the parking gear.

NOTE:

Do not drive the parking gear on with a hammer.

37. Remove the bolt and socket.

38. Use the old locknut to tighten the press fit parking gear to the specified torque, then loosen it.

TORQUE: 230 N·m (23.0 kg·m , 166 lb-ft)

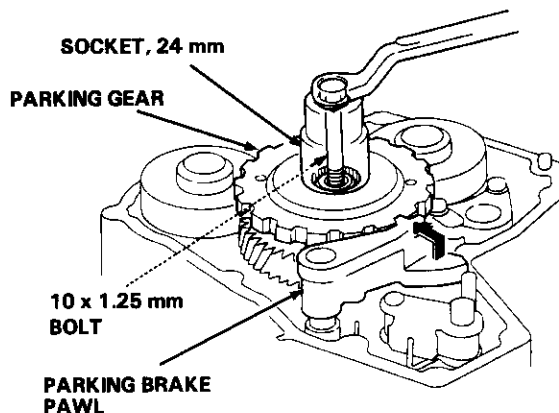

39. Remove the old locknuts, then install new conical spring washers and new locknuts on each shaft.

CAUTION:

Install the conical spring washers in the direction shown.

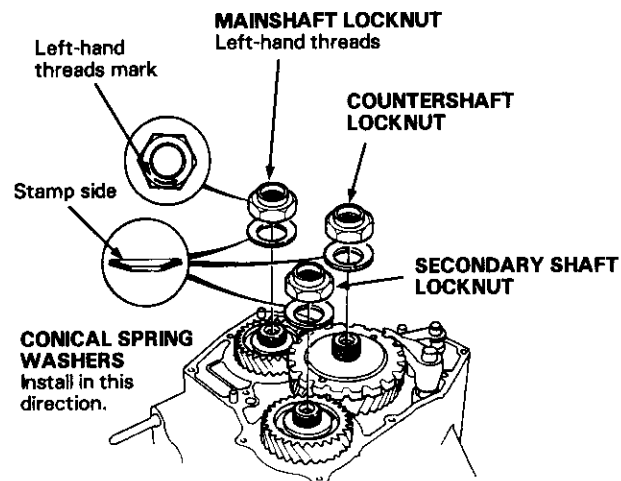



40. Tighten the locknuts to specified torque.

TORQUE:

Mainshaft 170 N·m (17.0 kg-m , 123 lb-ft)

Countershaft 170 N·m (17.0 kg-m , 123 lb-ft)

Secondary shaft 170 N·m (17.0 kg-m , 123 lb-ft)

NOTE:

The mainshaft locknut has left-hand threads.

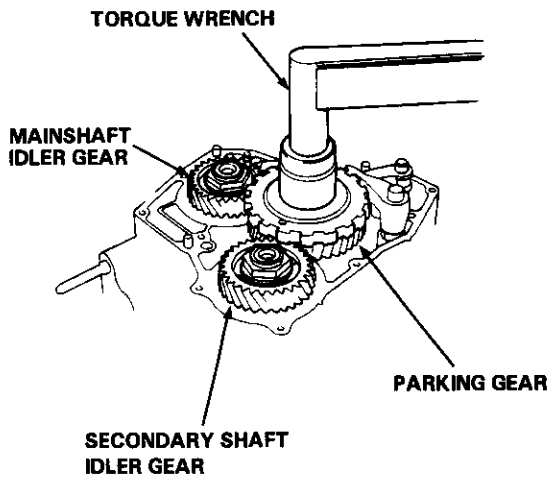

41. Stake each locknut into its shaft using a 3.5 mm punch.

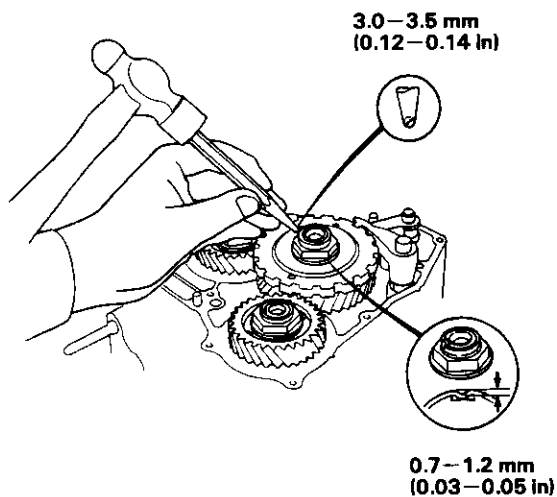

42. Set the parking brake lever in the **P** position, then verify that the parking brake pawl engages the parking gear.

43. If the pawl does not engage fully, check the parking brake pawl stopper clearance as described on page 14-136.

44. Tighten the lock bolt, and bend the lock tab against the bolt head.

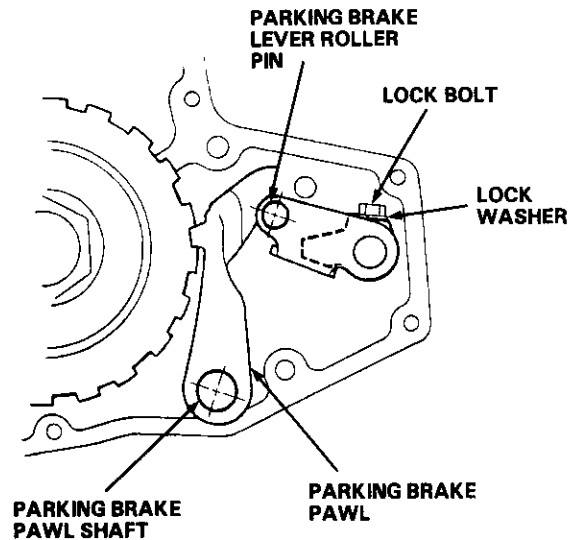

45. Install the right side cover.

TORQUE: 12 N·m (1.2 kg-m , 9 lb-ft)

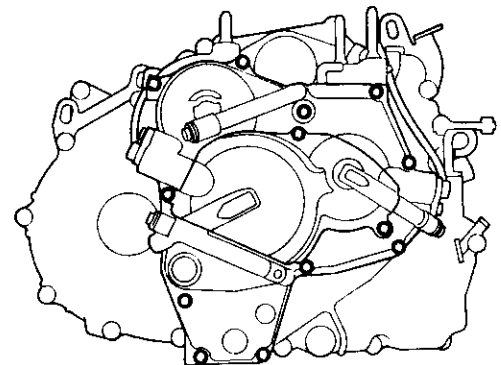

46. Install the ATF cooler pipes with new sealing washers.

TORQUE: 29 N·m (2.9 kg-m , 21 lb-ft)

47. Install the ATF level gauge.

Right Side Cover

Feed Pipe Installation

1. Install the feed pipes in the right side cover with new O-rings, aligning the lugs with the grooves in the right side over.
2. Install the snap rings.

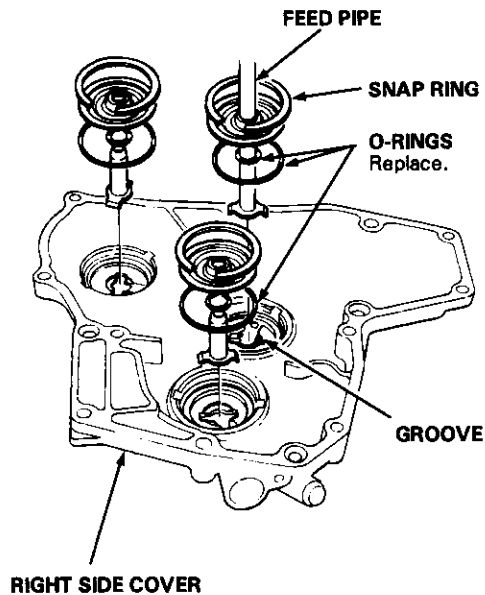

Parking Brake Stopper

Inspection/Adjustment

1. Set the parking brake lever in the **P** position.
2. Measure the distance between the parking brake pawl shaft and the parking brake lever roller pin as shown.

STANDARD: 64.5–65.5 mm (2.54–2.58 in)

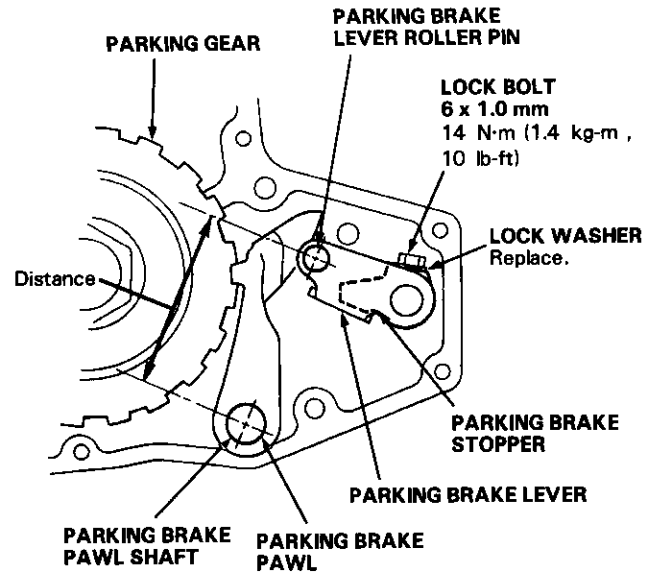

3. If the measurement is out of tolerance, select and install the appropriate parking brake stopper from the table below.

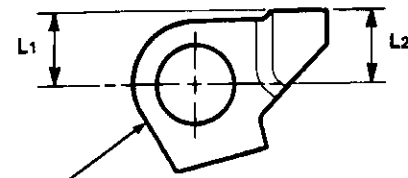

PARKING BRAKE STOPPER

PARKING BRAKE STOPPER

Mark	Part Number	L1	L2
1	24537-PA9-003	11.00 mm (0.433 in)	11.00 mm (0.433 in)
2	24538-PA9-003	10.80 mm (0.425 in)	10.65 mm (0.419 in)
3	24539-PA9-003	10.60 mm (0.417 in)	10.30 mm (0.406 in)

4. After replacing the parking brake stopper, make sure the distance is within tolerance.



Torque Converter

Disassembly

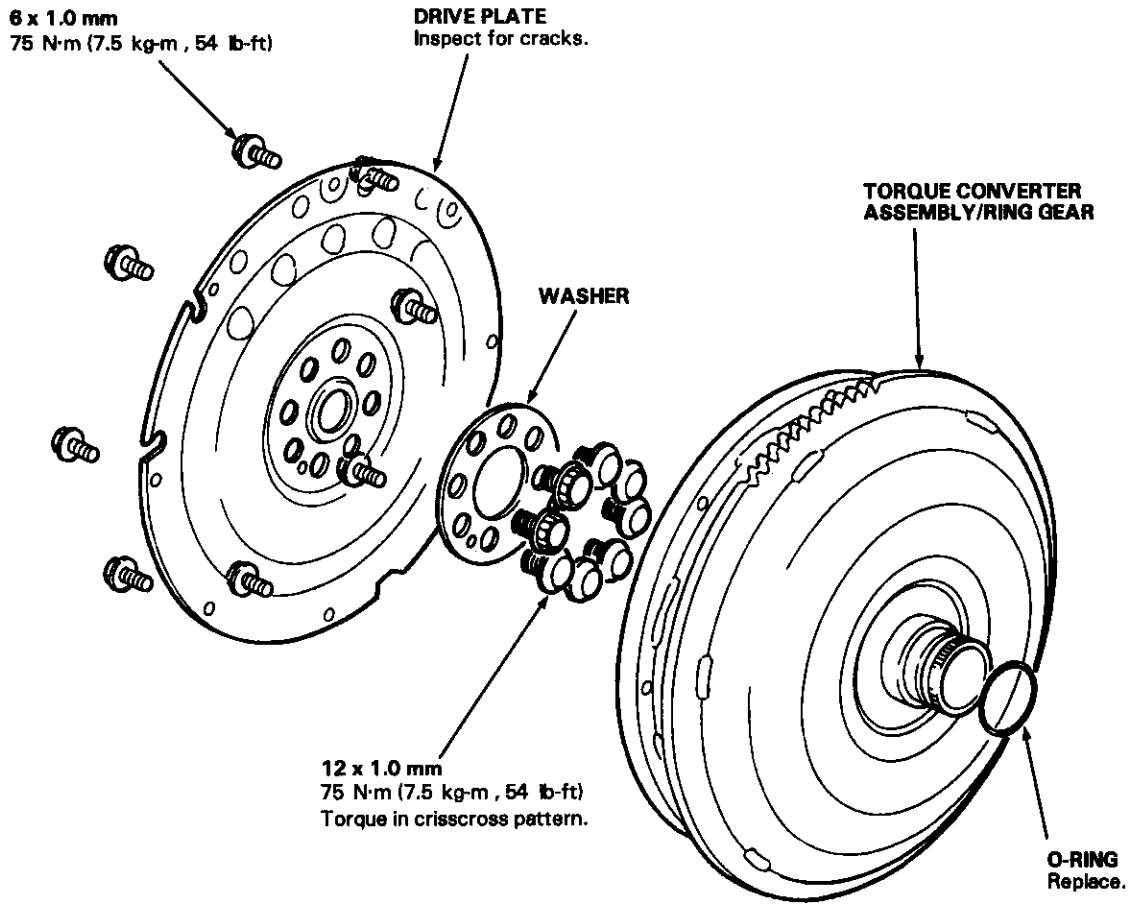

Transmission

Installation

1. Flush the ATF cooler as described on pages 14-142 and 143.
2. Install the starter motor on the torque converter housing, and install the two 14 x 20 mm dowel pins in the torque converter housing.

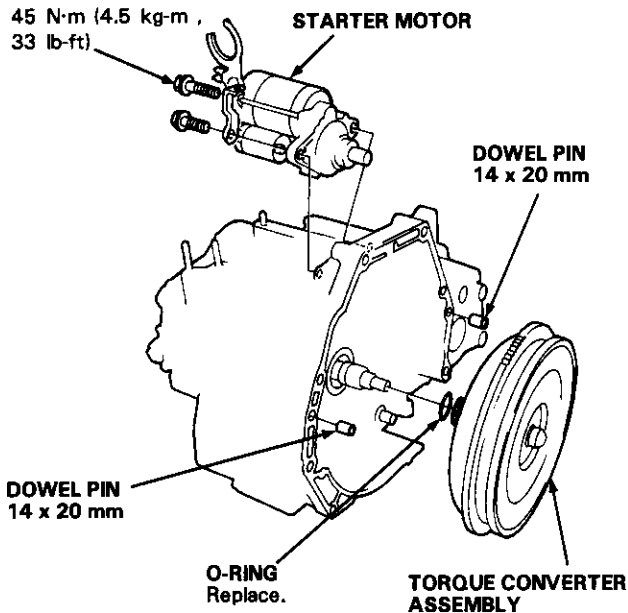

3. Place the transmission on a jack, and raise to the engine assembly level.
4. Attach the transmission on the engine, then install the transmission housing mounting bolts, rear engine mounting bolts and intake manifold bracket bolts.

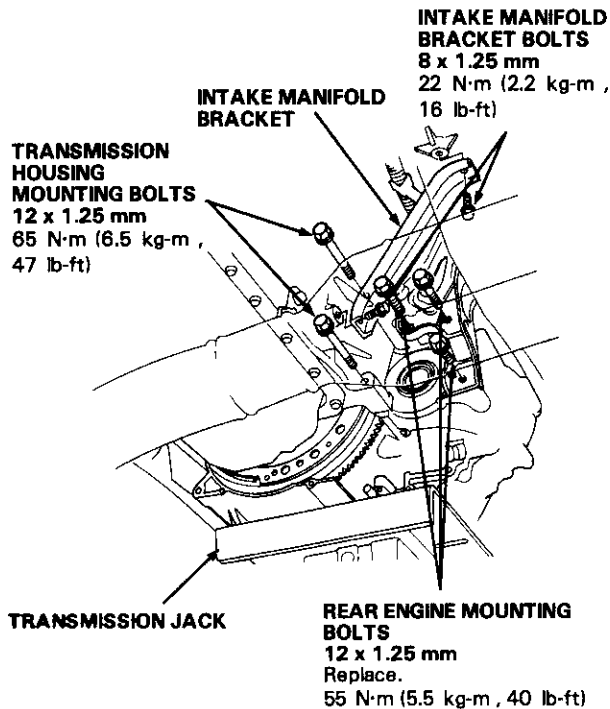

5. Install the transmission housing mounting bolts.

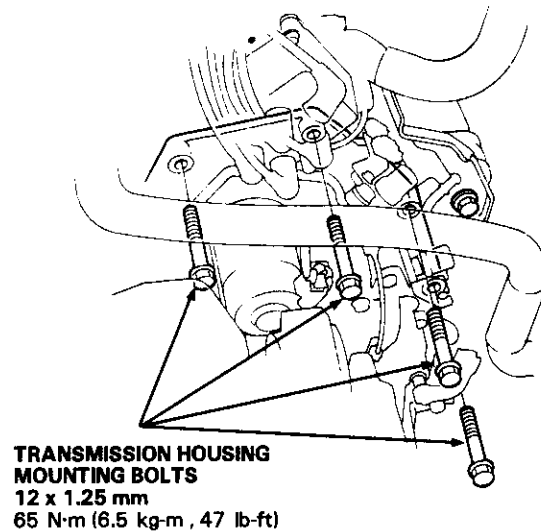

6. Tighten the front engine mount bracket bolts to specified torque.

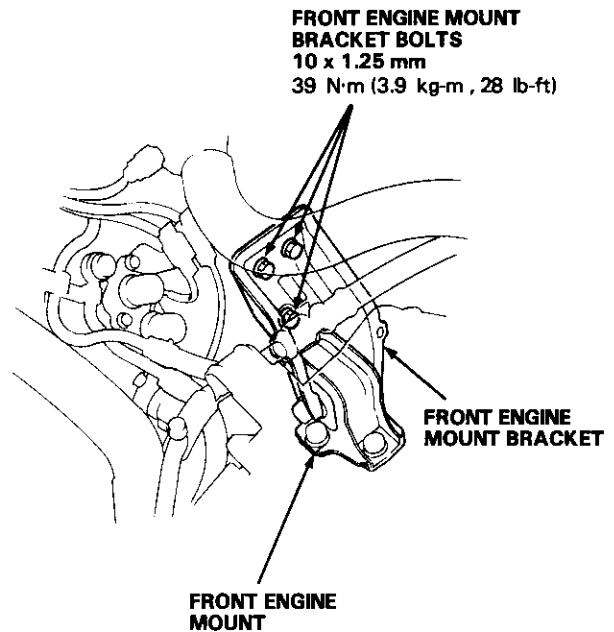



7. Install the transmission mount. Tighten the bolt then tighten the nuts to specified torque, and retighten the bolt to specified torque.

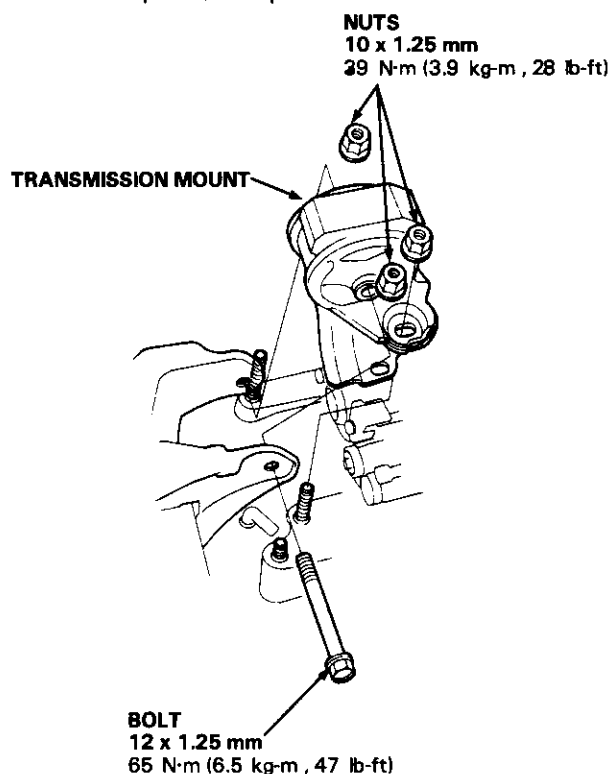

8. Remove the transmission jack.
9. Attach the torque converter to the drive plate with eight bolts, and torque to 12 N·m (1.2 kg-m, 9 lb-ft). Rotate the crankshaft as necessary to tighten the bolts to 1/2 of the specified torque, then final torque, in a crisscross pattern. After tightening the last bolt, check that the crankshaft rotates freely.

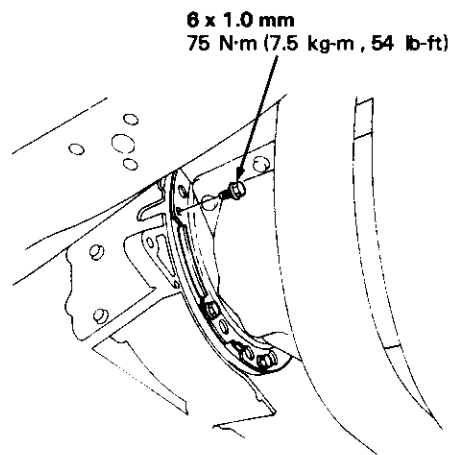

10. Install the control lever with the shift cable on the control shaft.

CAUTION:
Take care not to bend the shift cable.

11. Install the lock bolt with a new lock washer, then bend the lock tab.
12. Install the torque converter cover and shift cable cover.

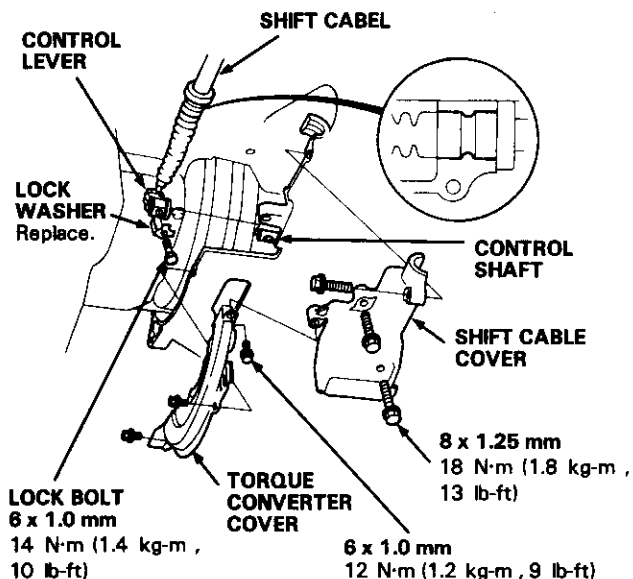

13. Install the right radius rod and damper fork.

NOTE:
Check for deterioration or damage of the radius rod rubber bushings.

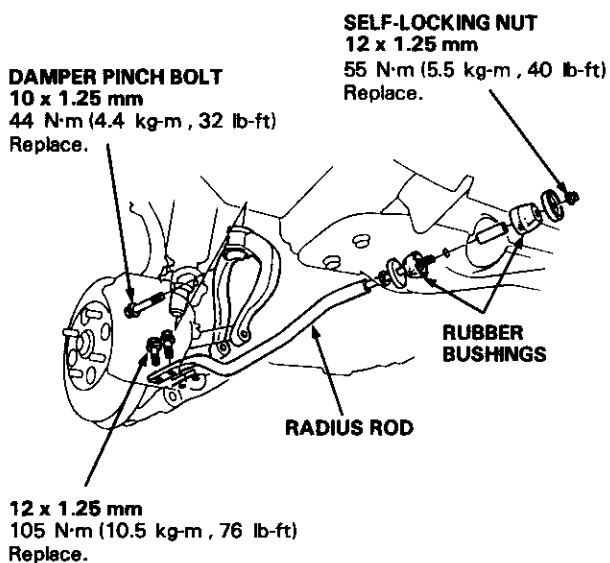

(cont'd)

Transmission

Installation (cont'd)

14. Install new set rings on the end of the driveshafts.
15. Install the right and left driveshafts.

NOTE:

Turn the right and left steering knuckles fully outward, and axially into the differential until you feel the set ring engage the side gear.

16. Install the damper fork to the lower arm. Then install the ball joint to the lower arm. Use the castle nuts with new cotter pins.

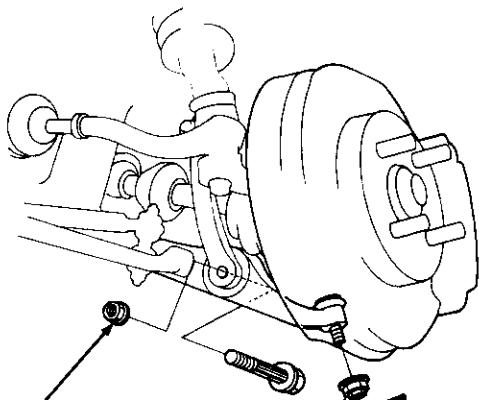

SELF-LOCKING NUT
12 x 1.25 mm
65 N·m (6.5 kg-m , 47 lb-ft)
Replace.

CASTLE NUT
12 x 1.25 mm
65 N·m (6.5 kg-m , 47 lb-ft)

COTTER PIN
Replace.

17. Install the rear beam stiffener and center beam.

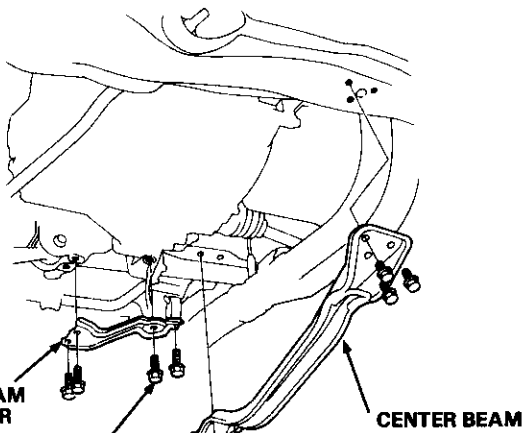

REAR BEAM STIFFENER

10 x 1.25 mm
39 N·m (3.9 kg-m , 28 lb-ft)

CENTER BEAM

10 x 1.25 mm
60 N·m (6.0 kg-m , 43 lb-ft)

18. Install the splash shield.

19. Install the vehicle speed sensor/power steering speed sensor and rear stiffener. Connect the vehicle speed sensor connector.

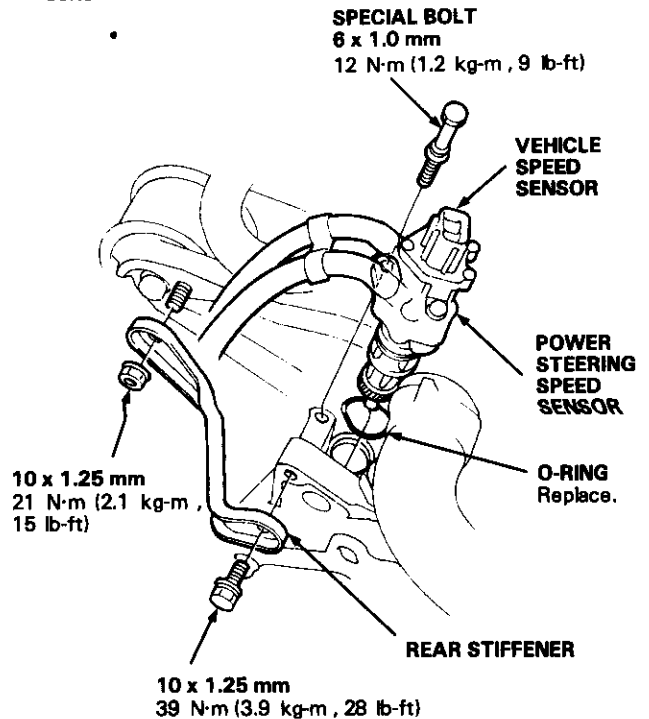

SPECIAL BOLT
6 x 1.0 mm
12 N·m (1.2 kg-m , 9 lb-ft)

VEHICLE SPEED SENSOR

POWER STEERING SPEED SENSOR

O-RING
Replace.

REAR STIFFENER

10 x 1.25 mm
21 N·m (2.1 kg-m , 15 lb-ft)

10 x 1.25 mm
39 N·m (3.9 kg-m , 28 lb-ft)

20. Connect the ATF cooler hoses to the joint pipes.
21. Connect the lock-up control solenoid, shift control solenoid valve connectors, and the throttle control cable.
22. Connect the mainshaft speed sensor connector.

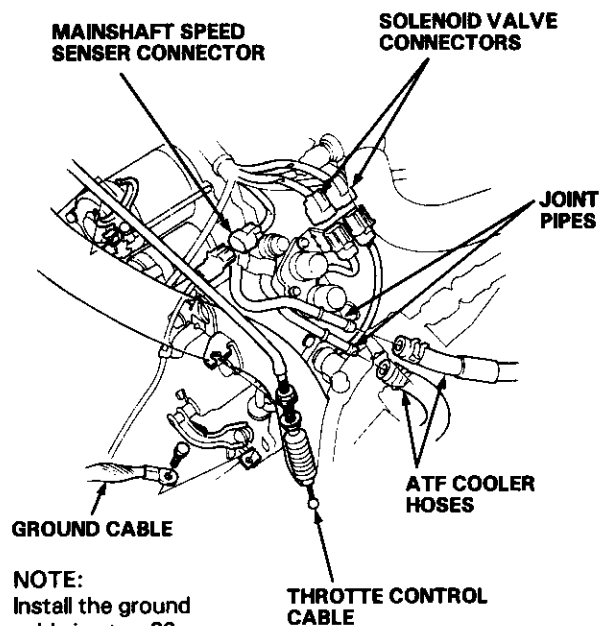

MAINSHAFT SPEED SENSER CONNECTOR

SOLENOID VALVE CONNECTORS

JOINT PIPES

ATF COOLER HOSES

GROUND CABLE

NOTE:
Install the ground cable in step 26.

THROTTLE CONTROL CABLE



23. Connect the countershaft speed sensor connector.
24. Connect the starter motor cables.

NOTE:

When installing the starter cable, make sure that the crimped side of the ring terminal is facing out (see section 23).

**COUNTERSHAFT SPEED
SENSOR CONNECTOR**

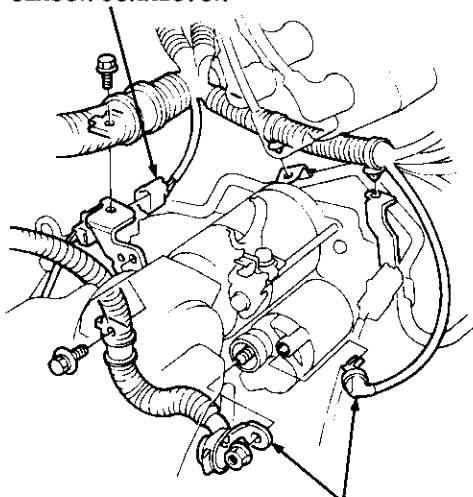

**STARTER MOTOR
CABLES**

25. Install the battery base and base stay.
26. Connect the ground cable to the body and the transmission.

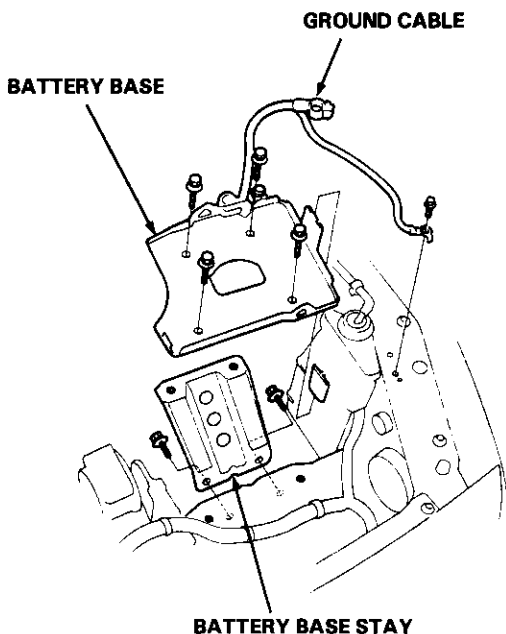

27. Install the intake control vacuum tank and intake control vacuum tank bracket, then connect the connector.
28. Install the air cleaner housing and intake air duct.
29. Refill the transmission with ATF (see page 14-72).
30. Connect the battery positive (+) and negative (-) cables to the battery.
31. Start the engine. Set the parking brake, and shift the transmission through all gears three times. Check for proper shift cable adjustment.
32. Check and adjust the front wheel alignment (see section 18).
33. Let the engine reach operating temperature (the radiator fan comes on) with the transmission in **N** or **P** position, then turn it off and check fluid level.
34. Road test as described on pages 14-68 thru 14-70.
35. Reset the radio stations.
36. Loosen the front engine mount bracket bolts after the road test, and retighten them to specified torque.

**FRONT ENGINE
MOUNT BRACKET
BOLTS**
10 x 1.25 mm
39 N·m (3.9 kg·m , 28 lb-ft)

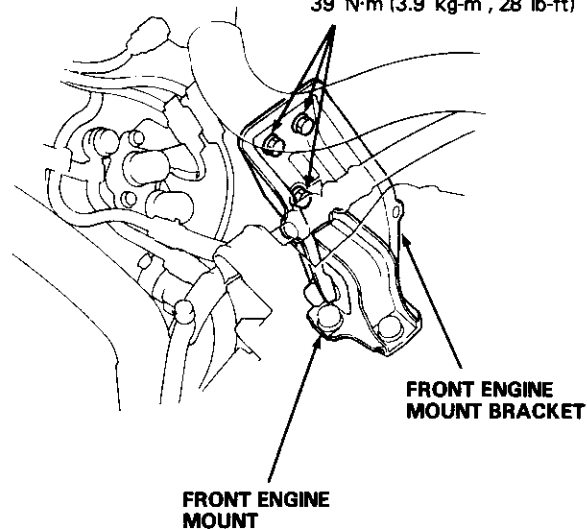

Transmission

Cooler Flushing

▲ WARNING

To prevent injury to face and eyes, always wear safety glasses or a face shield when using the transmission flusher.

NOTE:

This procedure should be performed before reinstalling the transmission.

1. Check tool and hoses for wear or cracks before using. If wear or cracks are found, replace the hoses before using.
2. Using the measuring cup, fill the tank with 21 ounces (approximately 2/3 full) of biodegradable flushing fluid (J35944-20). Do not substitute with any other fluid. Follow the handling procedure on the fluid container.
3. Secure the flusher filler cap and pressurize the tank with compress air to between 560-845 kpa (5.6-8.45 kg/cm², 80-120 psi).

NOTE:

The air line should be equipped with a water trap to ensure a dry air system.

4. Hang the tool under the vehicle.
5. Attach the discharge hose of the tank to the return line of the transmission cooler using a clamp.
6. Connect the drain hose to the inlet line of the transmission cooler using a clamp.

IMPORTANT:

Securely clamp the opposite end of the drain hose to a bucket or floor drain.

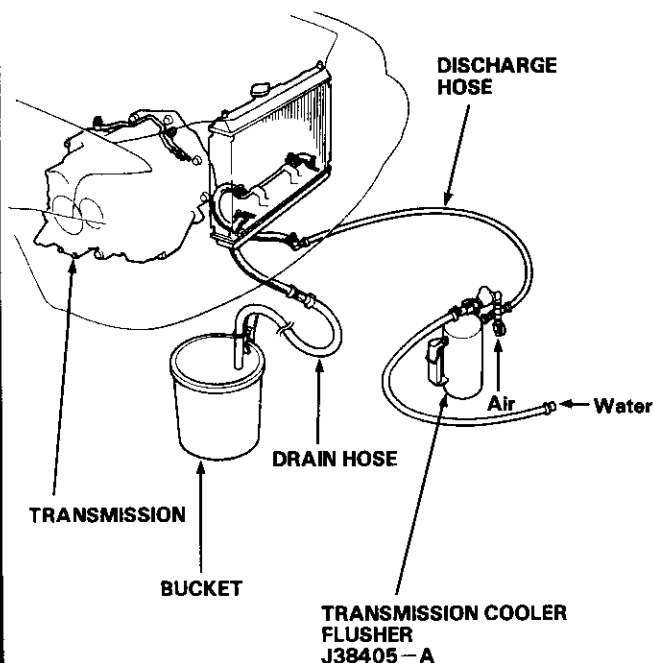

7. With the water and air valves off, attach the water and air supplies to the flusher. (Hot water if available.)

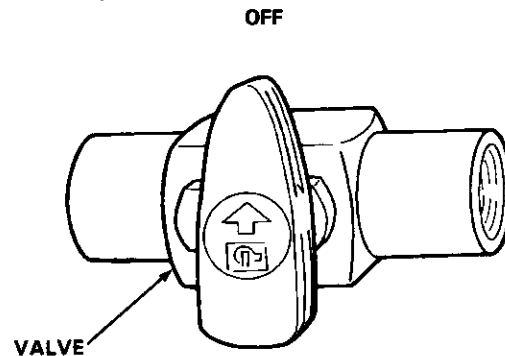

8. Turn on the flusher water valve so water will flow through the oil cooler for 10 seconds.

NOTE:

If water does not flow through the oil cooler it is completely plugged, cannot be flushed, and must be replaced.

9. Depress the trigger to mix the flushing fluid into the water flow. Use the wire clip to hold the trigger down.
 10. While flushing with the water and flushing fluid for 2 minutes, turn the air valve on for 5 seconds every 15-20 seconds to create a surging action.
AIR PRESSURE: MAX 845 kpa (8.45 kg/cm², 120 psi)
 11. Turn the water valve off. Release the trigger, then reverse the hoses to the cooler so you can flush in the opposite direction. Repeat steps 8 through 10.
 12. Release the trigger and allow water only to rinse the cooler with water for one minute.
 13. Turn the water valve off and turn off the water supply.
 14. Turn the air valve on to dry the system out with air for two full minutes or until no moisture is visible leaving the drain hose.
- CAUTION:**
Residual moisture in the oil cooler or pipes can damage the transmission.
15. Remove the flusher from the cooler line. Attach the drain hose to a oil container.
 16. Install the transmission and leave the drain hose attached to the cooler line.



17. Make sure the transmission is in **P** position.
Then fill the transmission with ATF and run the engine for 30 seconds or until approximately 0.95 l (1.0 US qt., 0.8 Imp qt.) is discharged.
18. Remove the drain hose and reconnect the cooler return hose to the transmission.
19. Refill the transmission with ATF to the proper level (see page 14-72).

TOOL MAINTENANCE

1. Empty and rinse after each use. Fill the can with water and pressurize the can. Flush the discharge line to ensure that the unit is clean.
2. If discharge liquid does not foam, the orifice may be blocked.
3. To clean, disconnect the plumbing from the tank at the large coupling nut.
4. Remove the in-line filter from the discharge side and clean if necessary.
5. The fluid orifice is located behind the filter. Clean it with the pick stored in the bottom of the tank handle or blow it clean with air. Securely reassemble all parts.

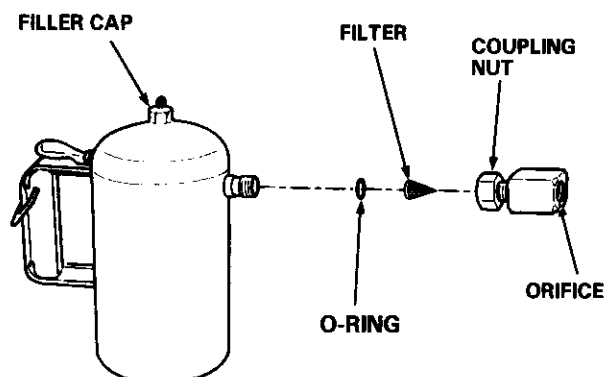

Shift Cable

Removal/Installation

▲ WARNING

- Make sure lifts, jacks and safety stands are placed properly, and hoist brackets are attached to the correct position on the engine (see section 1).
- Apply parking brake and block rear wheels, so car will not roll off stands and fall on you while working under it.

CAUTION:

- All SRS electrical wiring harnesses are covered with yellow outer insulation.
- Before disconnecting the SRS wire harness, install the short connector(s) on the airbag(s).
- Replace the entire affected SRS harness assembly if it has an open circuit or damaged wiring.

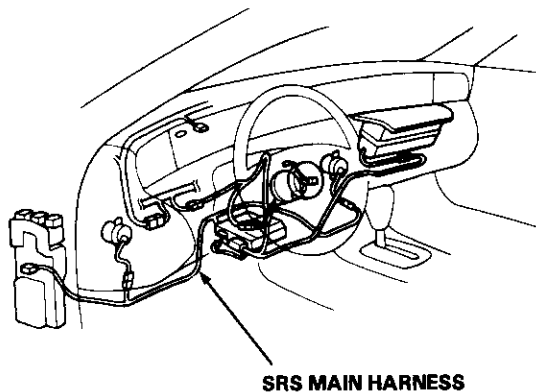

1. Remove the front console (see section 20).
2. Shift to **N** position, then remove the lock pin from the cable adjuster.
3. Remove the bolts securing the bracket.

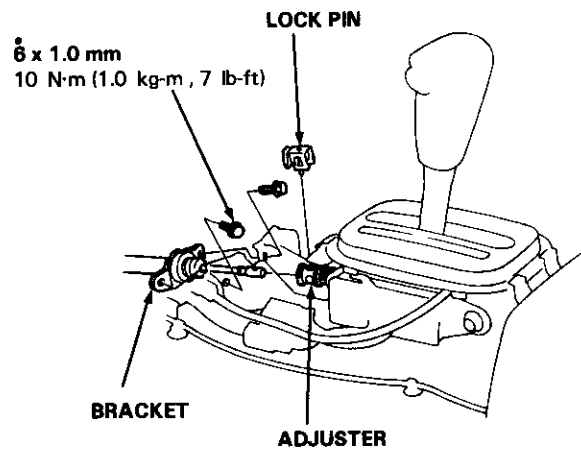

4. Remove the shift cable cover.
5. Remove the lock bolt securing the control lever, then remove the control lever with the shift cable.

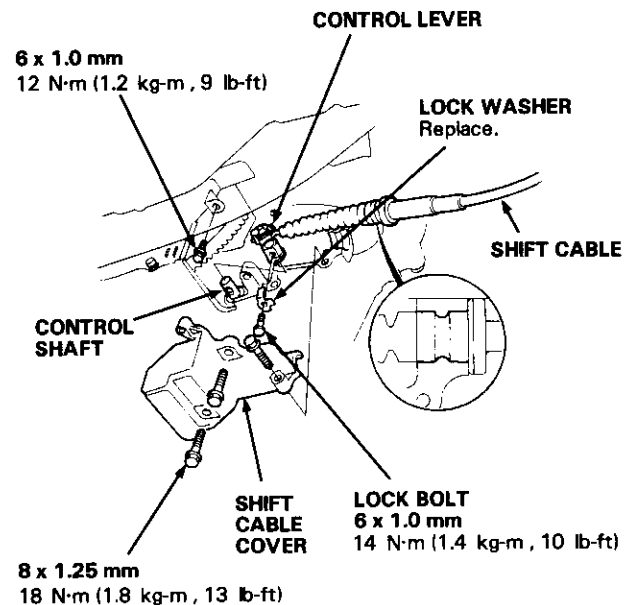



6. Remove the exhaust pipe B and heat shield.

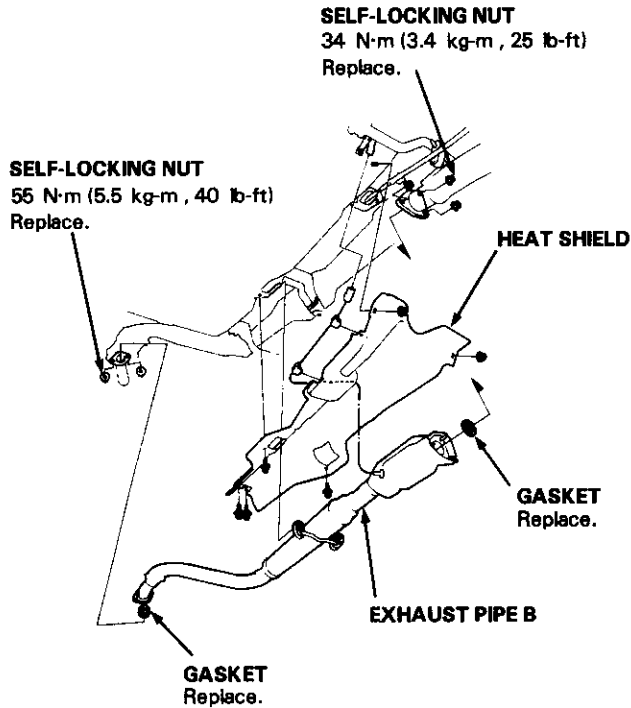

7. Remove the cable guide and grommet.

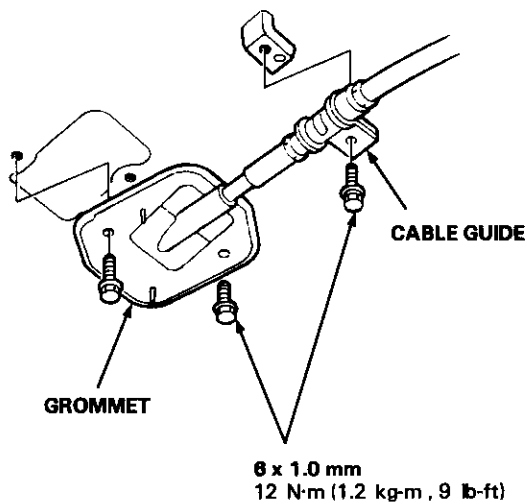

8. Remove the cotter pin and lock pin, then separate the control lever from the shift cable.

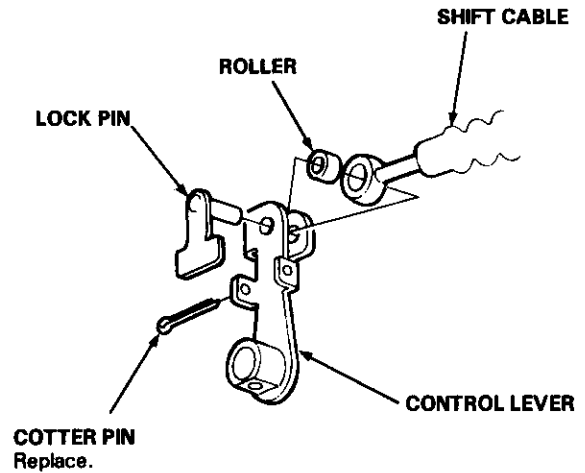

9. Install the shift cable in the reverse order of removal.

10. Check the cable adjustment after installing the shift cable (see page 14-146).

Shift Cable

Adjustment

CAUTION:

- All SRS electrical wiring harnesses are covered with yellow outer insulation.
- Before disconnecting the SRS wire harness, install the short connector (s) on the airbag (s).
- Replace the entire affected SRS harness assembly if it has an open circuit or damaged wiring.

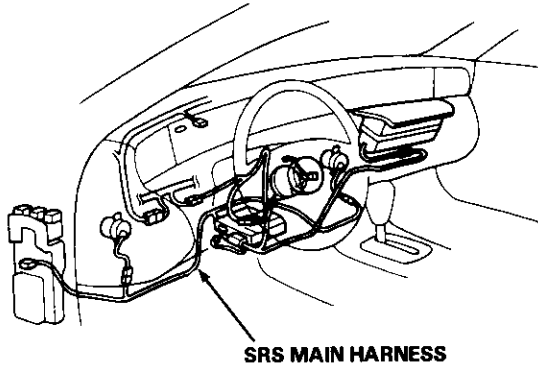

1. Start the engine. Shift to reverse to see if the reverse gear engages. If not, refer to Troubleshooting on page 14-64 thru 67.
2. With the engine off, remove the front console (see section 20).
3. Shift to **N** position, then remove the lock pin from the cable adjuster.

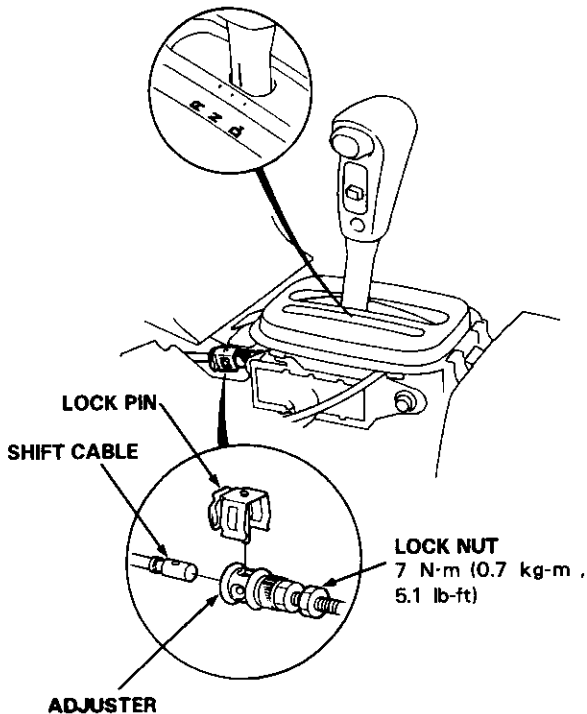

4. Check that the hole in the adjuster is perfectly aligned with the hole in the shift cable.

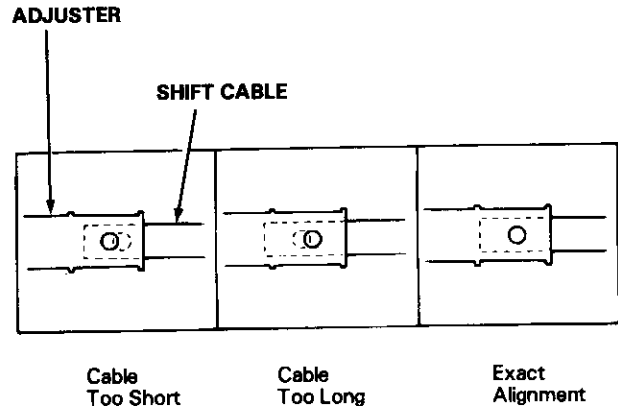

NOTE:

There are two holes in the end of the shift cable. They are positioned 90° apart to allow cable adjustments in 1/4 turn increments.

5. If not perfectly aligned, loosen the locknut on the shift cable, and adjust as required.
6. Tighten the locknut.
7. Install the lock pin on the adjuster. If you feel the lock pin binding as you reinstall it, the cable is still out of adjustment and must be readjusted.
8. Move the shift lever to each gear and verify that the A/T gear position indicator follows the A/T gear position switch.
9. Start the engine and check the shift lever in all gears. If any gear does not work properly, refer to troubleshooting on page 14-64 thru 67.
10. Insert the ignition key into the key cylinder on the A/T gear indicator panel, and verify that the shift lock lever is released.

Gearshift Selector



CAUTION:

- All SRS electrical wiring harnesses are covered with yellow outer insulation.
- Before disconnecting the SRS wire harness, install the short connector (s) on the airbag (s).
- Replace the entire affected SRS harness assembly if it has an open circuit or damaged wiring.

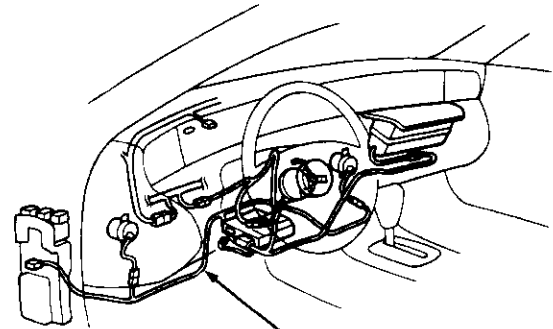

SRS MAIN HARNESS

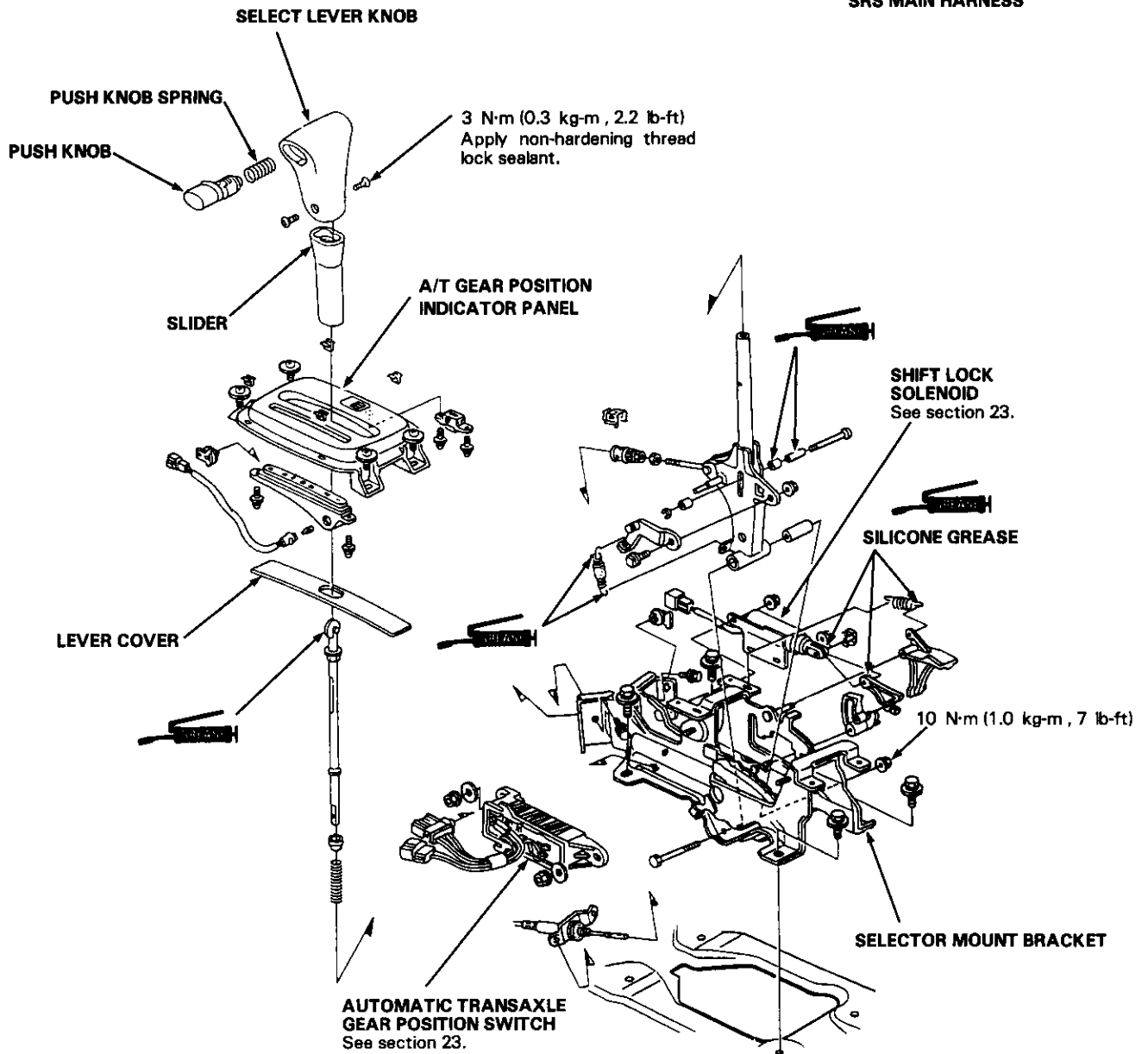

A/T Gear Position Indicator Panel

Adjustment

CAUTION:

- All SRS electrical wiring harnesses are covered with yellow outer insulation.
- Before disconnecting the SRS wire harness, install the short connector (s) on the airbag (s).
- Replace the entire affected SRS harness assembly if it has an open circuit or damaged wiring.

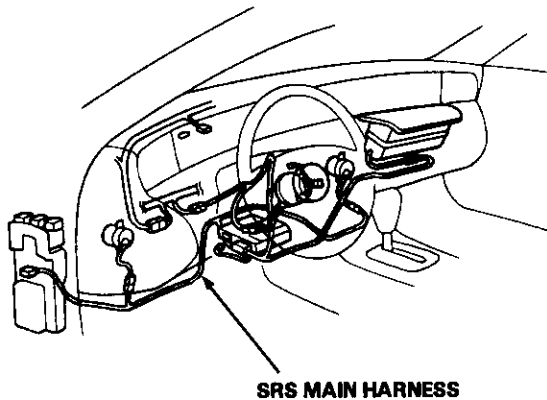

1. With the transmission in **N** position, check that the index mark on the indicator aligns with the N mark on the A/T gear position indicator panel when the transmission is in **N** position.
2. If not aligned, remove the front console (see section 20).
3. Remove the A/T gear position indicator panel mounting screws, and adjust by moving the panel.

NOTE:

Whenever the A/T gear position indicator panel is removed, reinstall the panel as described above.

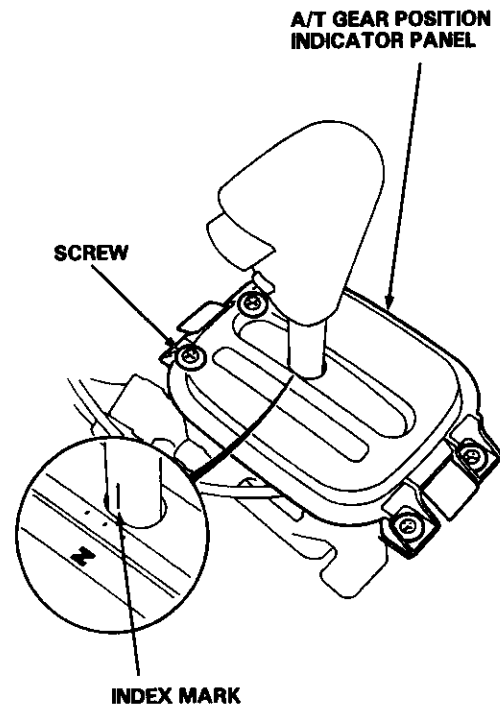



Throttle Control Cable

Inspection

NOTE:

Before inspecting the throttle control cable, make sure that:

- Throttle cable free play is correct (see section 11).
 - Idle speed is correct (see section 11).
 - You warm up the engine to normal operating temperature (the radiator fan comes on).
1. Verify that the throttle control lever is synchronized with the throttle linkage while depressing and releasing the accelerator pedal.
 2. If the throttle control lever is not synchronized with the throttle linkage, adjust the throttle control cable.

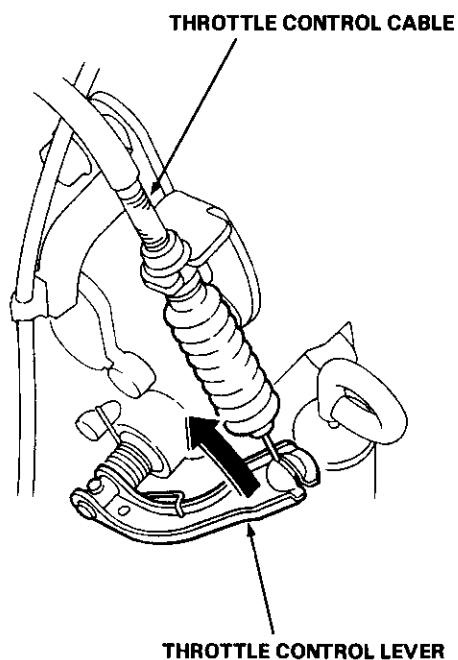
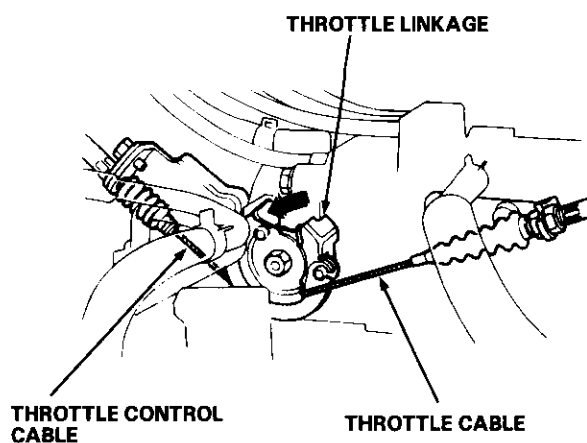

3. Check that there is play in the throttle control lever while depressing the accelerator pedal to the full-throttle position.

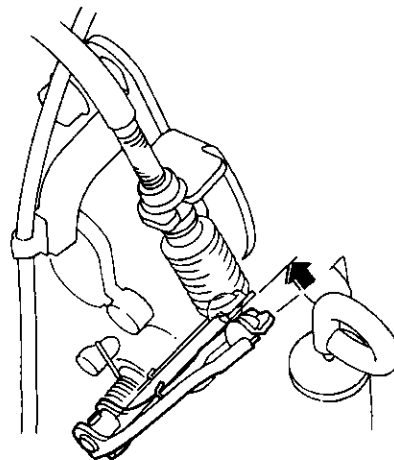

4. Remove the cable end of the throttle control cable from the throttle control lever.
5. Check that the throttle control lever moves smoothly.

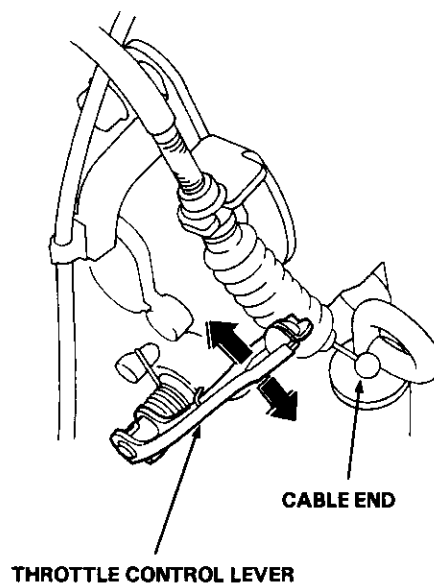

Throttle Control Cable

Adjustment

NOTE:

Before adjusting the throttle control cable, make sure that:

- Throttle cable free play is correct (see section 11).
- Idle speed is correct (see section 11).
- You warm up the engine to normal operating temperature (the radiator fan comes on).

1. Verify that the throttle linkage is in the fully-closed position.

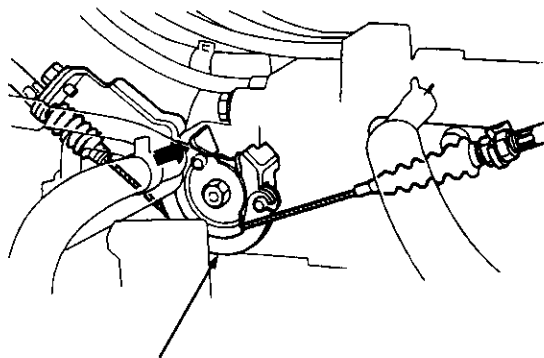

THROTTLE LINKAGE

2. Loosen the locknut on the throttle control cable at the throttle control lever.
3. Remove the free play in the throttle control cable with the locknut, while pushing the throttle control lever to the fully-closed position as shown.

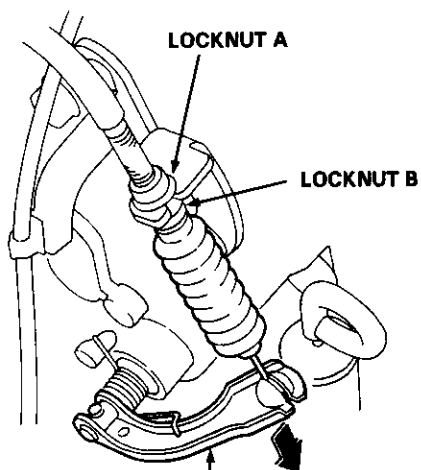

THROTTLE CONTROL LEVER
Push in this direction.

4. Tighten the locknuts.

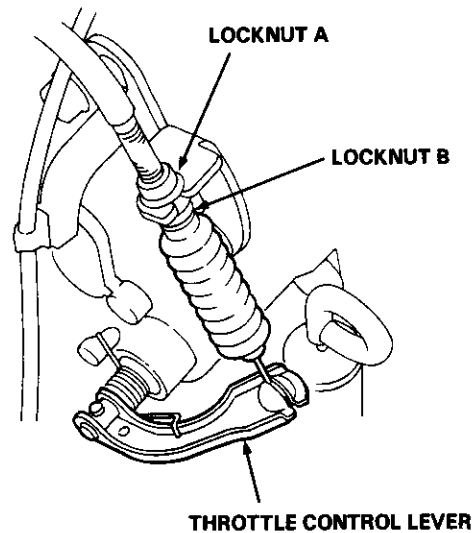

5. After tightening the locknuts, inspect the synchronization and throttle control lever movement.

NOTE:

To tailor the shift/lock-up characteristics to a particular customer's driving expectations, you can adjust the throttle control cable up to 2mm (0.078 in) shorter than the "synchronized" point.

Differential

Manual Transmission	15-1
Automatic Transmission	15-10



Differential (Manual Transmission)

Special Tools	15-2
Differential	
Illustrated Index	15-3
Backlash Inspection	15-4
Final Driven Gear Replacement	15-4
Tapered Roller Bearing Replacement	15-5
Oil Seal Removal	15-5
Bearing Outer Race Replacement	15-6
Tapered Roller Bearing Preload Adjustment	15-7
Oil Seal Installation	15-9



Special Tools

Ref. No.	Tool Number	Description	Qty	Page Reference
①	07GAD — PG40100	Driver Attachment	1	15-9
②	07HAJ — PK40201	Preload Inspection Tool	1	15-7
③	07JAD — PH80101	Driver Attachment	1	15-9
④	07JAD — PH80400	Pilot, 28 x 30 mm	1	15-9
⑤	07LAD — PW50601	Attachment, 40 x 50 mm I.D.	1	15-5
⑥	07746 — 0010400	Attachment, 52 x 55 mm	1	15-6
⑦	07746 — 0010500	Attachment, 62 x 68 mm	1	15-6
⑧	07746 — 0010600	Attachment, 72 x 75 mm	1	15-6
⑨	07749 — 0010000	Driver	1	15-6, 9

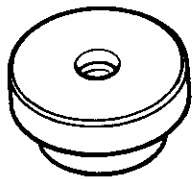

①

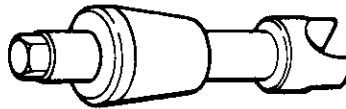

②

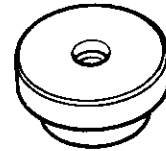

③



④



⑤

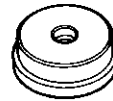

⑥

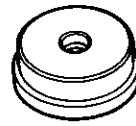

⑦

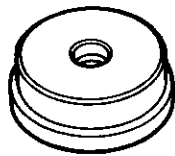

⑧



⑨

Differential (Manual Transmission)



Illustrated Index

NOTE: If the * mark parts were replaced, the tapered roller bearing preload must be adjusted (see page 15-9).

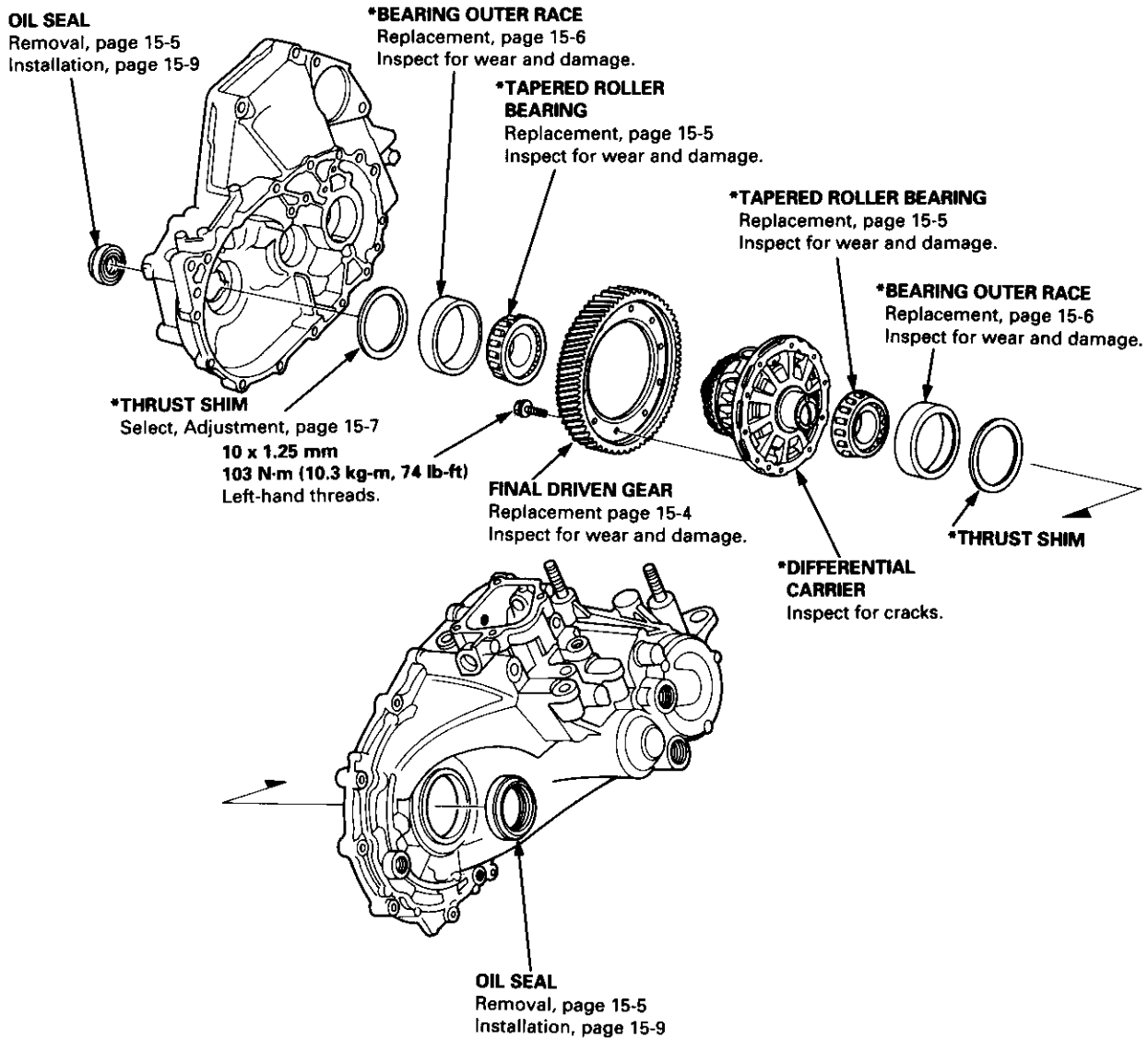

Differential (Manual Transmission)

Backlash Inspection

1. Place differential assembly on V-blocks and install both driveshafts.
2. Measure the backlash of both pinion gears.

**Standard (New): 0.05 — 0.15 mm
(0.002 — 0.006 in)**

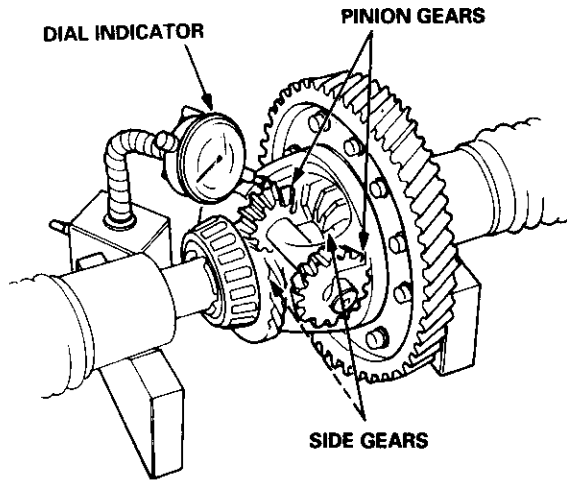

3. If the backlash is not within the standard, replace the differential carrier.

Final Driven Gear Replacement

1. Remove the bolts in a crisscross pattern in several steps, and remove the final driven gear from the differential carrier.

NOTE: The final driven gear bolts have left-hand threads.

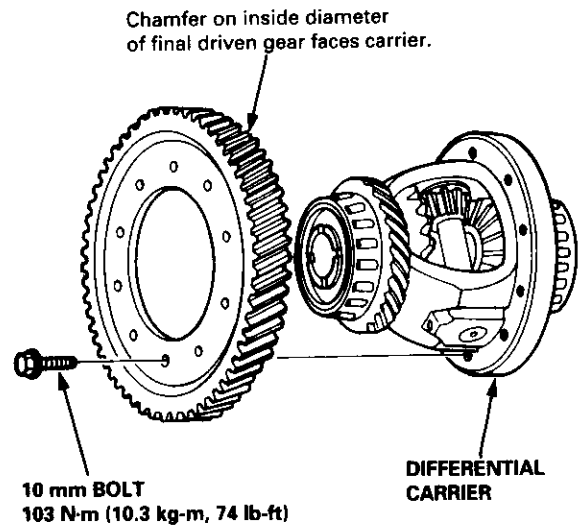

2. Install the final driven gear by tightening the bolts in a crisscross pattern in several steps.



Tapered Roller Bearing Replacement

NOTE:

- The tapered roller bearing and bearing outer race should be replaced as a set.
- Inspect and adjust the tapered roller bearing preload whenever the tapered roller bearing is replaced.
- Check the tapered roller bearings for wear and rough rotation. If tapered roller bearings are OK, removal is not necessary.

1. Remove the tapered roller bearings using a bearing puller.

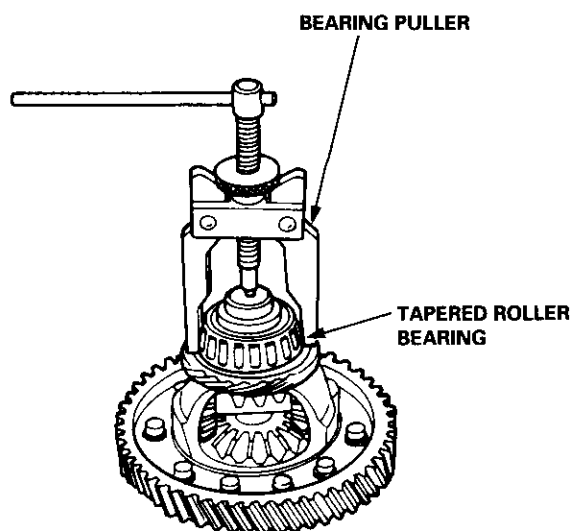

2. Install new tapered roller bearings using the special tool as shown.

NOTE: Drive the tapered roller bearings on until they bottom against the differential carrier.

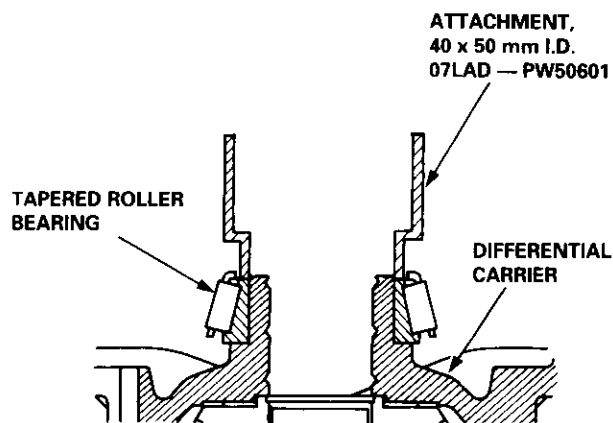

Oil Seal Removal

1. Remove the differential assembly.
2. Remove the oil seal from the transmission housing.

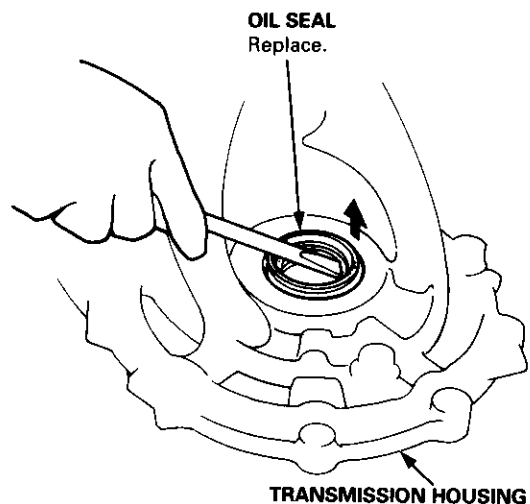

3. Remove the oil seal from the clutch housing.

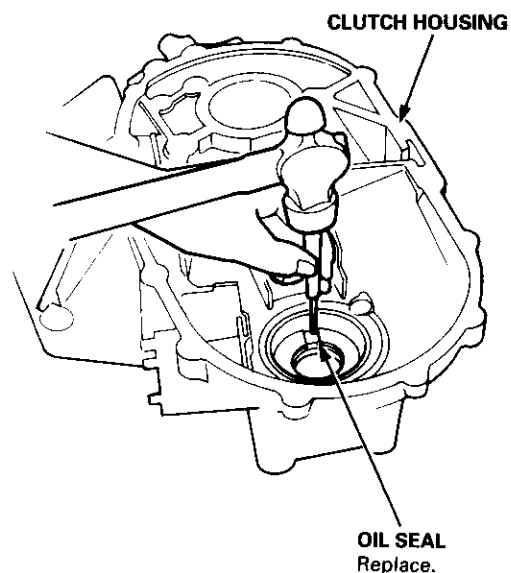

Differential (Manual Transmission)

Bearing Outer Race Replacement

NOTE:

- The bearing outer race and tapered roller bearing should be replaced as a set.
- Inspect and adjust the tapered roller bearing preload whenever the tapered roller bearing is replaced.

1. Remove the oil seals from the transmission housing and clutch housing (see page 15-5).
2. Drive the bearing outer race and thrust shim out of the transmission housing, or remove the bearing outer race and thrust shim from the transmission housing by heating the transmission housing to about 212°F (100°C) with a heat gun.

CAUTION: Do not reuse the thrust shim if the outer race was driven out.

NOTE: Do not heat the transmission housing in excess of 212°F (100°C).

TRANSMISSION HOUSING:

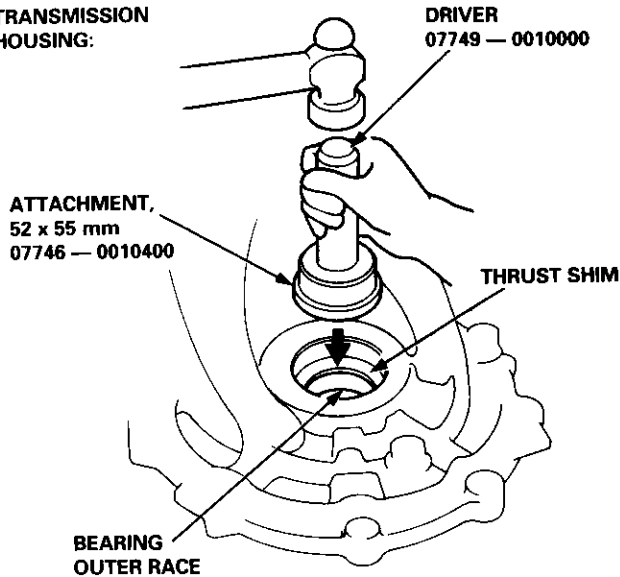

CLUTCH HOUSING:

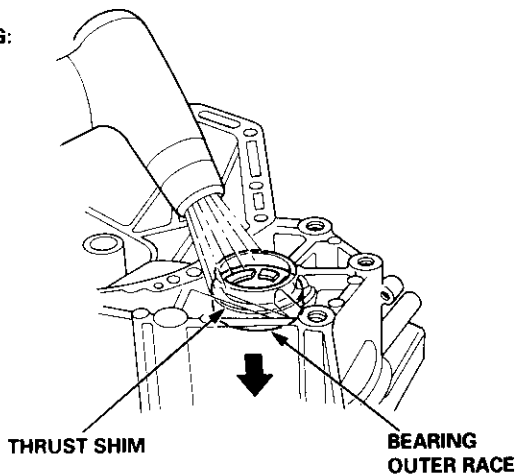

3. After installing the thrust shim, install an bearing outer race in the transmission housing and clutch housing using the special tools as shown.

NOTE:

- Install the bearing outer race squarely.
- Check that there is no clearance between the bearing outer race, thrust shim, and transmission housing.

TRANSMISSION HOUSING:

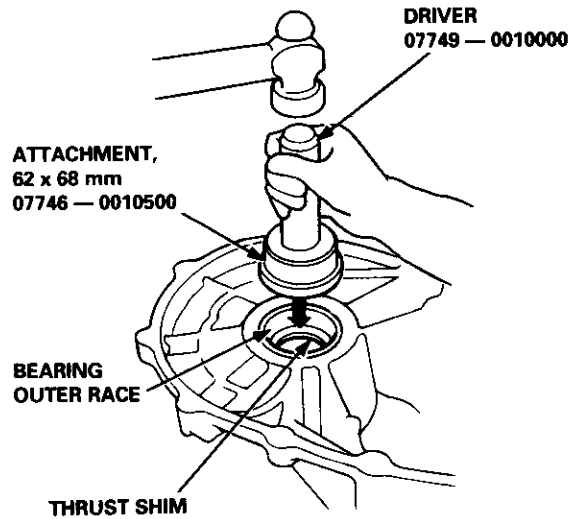

CLUTCH HOUSING:

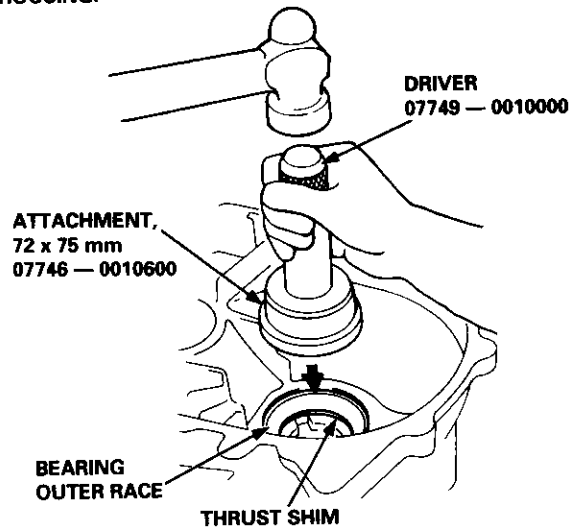

4. Install the oil seal (see page 15-9).



Tapered Roller Bearing Preload Adjustment

NOTE: If any of the items listed below were replaced, the tapered roller bearing preload must be adjusted.

- Transmission housing
- Clutch housing
- Differential carrier
- Tapered roller bearing and bearing outer race
- Thrust shim

1. Remove the bearing outer race and thrust shim from the transmission housing (see page 15-6).

NOTE: Install the thrust shim only on the transmission housing side.

CAUTION: Do not reuse the thrust shim if the bearing outer race was driven out.

NOTE: Let the transmission cool to the room temperature if the bearing outer race was removed by heating the transmission housing before adjusting the tapered roller bearing preload.

2. First try the same size thrust shim that was removed.

CAUTION: Use only one thrust shim.

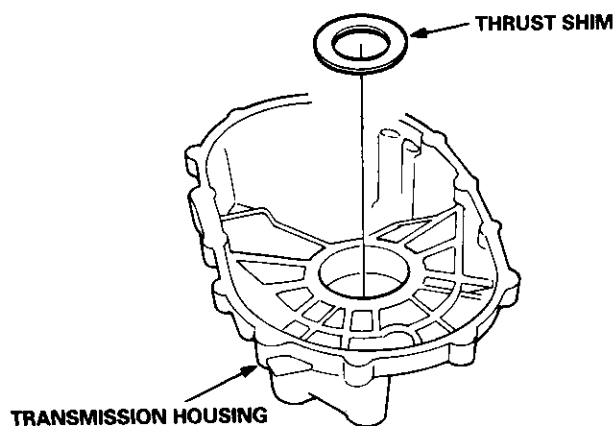

3. After installing the thrust shim, install the bearing outer race in the transmission housing (see page 15-6).

NOTE:

- Install the bearing outer race squarely.
- Check that there is no clearance between the bearing outer race, thrust shim and transmission housing.

4. With the mainshaft and countershaft removed, install the differential assembly, and torque the clutch housing and transmission housing.

TORQUE: 10 x 1.25 mm: 45 N·m
(4.5 kg·m, 33 lb·ft)
8 x 1.25 mm: 28 N·m
(2.8 kg·m, 20 lb·ft)

NOTE: It is not necessary to use sealing agent between the housings.

5. Rotate the differential assembly in both directions to seat the tapered roller bearings.
6. Measure the starting torque of the differential assembly with the special tool and a torque wrench.

STANDARD: 1.4 — 2.6 N·m
(14 — 26 kg·cm, 12 — 23 lb·in)

NOTE:

- Measure the tapered roller bearing preload at normal room temperature.
- Measure the tapered roller bearing preload in both directions.

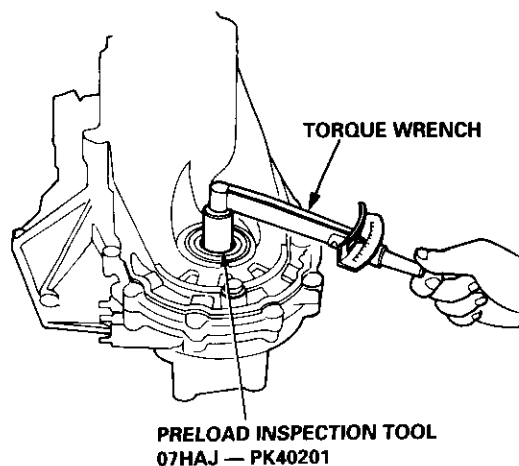

(cont'd)

Differential (Manual Transmission)

Tapered Roller Bearing Preload Adjustment (cont'd)

7. If the tapered roller bearing preload is not within the standard, select the thrust shim which will give the correct tapered roller bearing preload from the following table.

NOTE: Changing the thrust shim to the next size will increase or decrease tapered roller bearing preload about 3 — 4 kg-cm (2.60 — 3.47 lb-in).

THRUST SHIM

	Part Number	Thickness
A	41381 — PX5 — 000	1.90 mm (0.075 in)
B	41382 — PX5 — 000	1.93 mm (0.076 in)
C	41383 — PX5 — 000	1.96 mm (0.077 in)
D	41384 — PX5 — 000	1.99 mm (0.078 in)
E	41385 — PX5 — 000	2.02 mm (0.079 in)
F	41386 — PX5 — 000	2.05 mm (0.081 in)
G	41387 — PX5 — 000	2.08 mm (0.082 in)
H	41388 — PX5 — 000	2.11 mm (0.083 in)
I	41389 — PX5 — 000	2.14 mm (0.084 in)
J	41390 — PX5 — 000	2.17 mm (0.085 in)
K	41391 — PX5 — 000	2.20 mm (0.087 in)
L	41392 — PX5 — 000	2.23 mm (0.088 in)
M	41393 — PX5 — 000	2.26 mm (0.089 in)
N	41394 — PX5 — 000	2.29 mm (0.090 in)
O	41395 — PX5 — 000	2.32 mm (0.091 in)
P	41396 — PX5 — 000	2.35 mm (0.092 in)
Q	41397 — PX5 — 000	2.38 mm (0.094 in)
R	41398 — PX5 — 000	2.41 mm (0.095 in)
S	41399 — PX5 — 000	2.44 mm (0.096 in)
T	41400 — PX5 — 000	2.47 mm (0.097 in)

8. Recheck the tapered roller bearing preload.

9. How to select the correct thrust shim:

- 1) Compare the tapered roller bearing preload you get with the thrust shim that was removed, with the specified preload of 14 — 26 kg-cm (12 — 23 lb-in).
- 2) If your measured tapered roller bearing preload is less than specified, subtract yours from the specified.
If yours is more than specified, subtract the specified from your measurement.

For example with a 2.17 mm thrust shim:

$$\begin{array}{r}
 \textcircled{A} \text{ specified} \quad 26 \text{ kg-cm (23 lb-in)} \\
 - \text{you measure} \quad 6 \text{ kg-cm (5 lb-in)} \\
 \hline
 20 \text{ kg-cm (18 lb-in) less} \\
 \\
 \textcircled{B} \text{ you measure} \quad 34 \text{ kg-cm (30 lb-in)} \\
 - \text{specified} \quad 26 \text{ kg-cm (23 lb-in)} \\
 \hline
 8 \text{ kg-cm (7 lb-in) more}
 \end{array}$$

- 3) Each shim size up or down from standard makes about 3 — 4 kg-cm (2.60 — 3.47 lb-in) difference in tapered roller bearing preload.

- In example A, your measured tapered roller bearing preload was 20 kg-cm less than standard so you need a thrust shim five sizes thicker than standard (try the 2.32 mm thrust shim, and recheck).
- In example B, yours was 8 kg-cm more than standard, so you need a thrust shim two sizes thinner (try the 2.11 mm thrust shim, and recheck).

10. After adjusting the tapered roller bearing preload, assemble the transmission and install the transmission housing (see page 13-31).

TORQUE: 10 x 1.25 mm: 45 N-m
(4.5 kg-m, 33 lb-ft)

8 x 1.25 mm: 28 N-m
(2.8 kg-m, 20 lb-ft)

11. Rotate the differential assembly in both directions to seat the tapered roller bearings.



Oil Seal Installation

1. Install the new oil seal flush with the transmission housing using the special tools as shown.

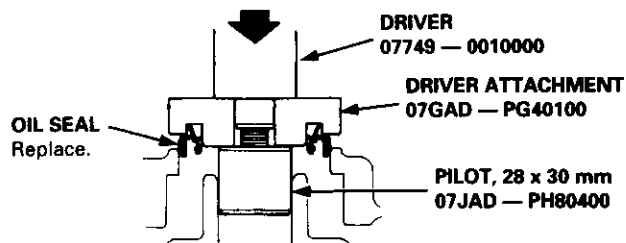
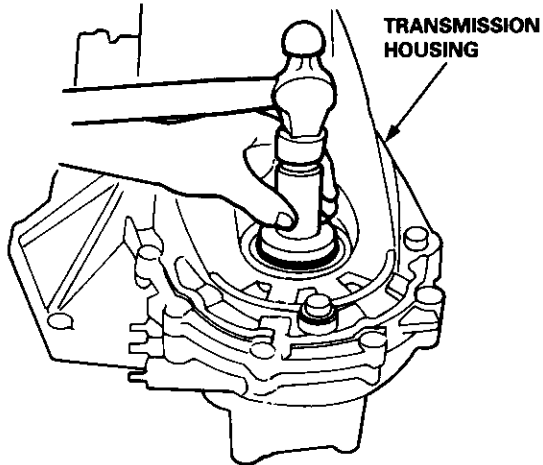

2. Install the new oil seal into the clutch housing using the special tools as shown.

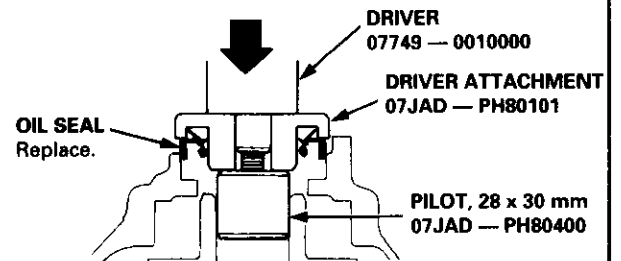
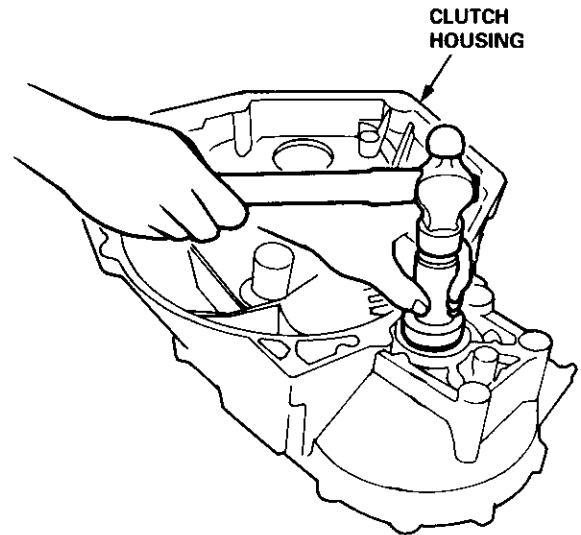

Differential (Automatic Transmission)

Special Tools	15-12
Differential (Automatic Transmission)	
Illustrated Index	15-13
Backlash Inspection	15-14
Bearing Replacement	15-14
Inspection/Disassembly	15-15
Reassembly	15-16
Oil Seal Removal	15-17
Taper Roller Bearing Preload Adjustment	15-18
Bearing Outer Race Replacement	15-20
Oil Seal Installation	15-20



Special Tools

Ref. No.	Tool Number	Description	Qty	Page Reference
①	07GAD — SD40101 or 07GAD — SD40100	Driver Attachment	1	15-20
②	07HAJ — PK40201	Preload Inspection Tool	1	15-19
③	07HAD — SF10100	Driver Attachment	1	15-19
④	07JAD — PH80101	Driver Attachment	1	15-20
⑤	07JAD — PH80400	Pilot, 28 x 30 mm	1	15-20
⑥	07LAD — PW50601	Attachment, 40 x 50 mm	1	15-14
⑦	07749 — 0010000	Driver	1	15-19, 20
⑧	07947 — SD90200	Driver Attachment	1	15-20



①

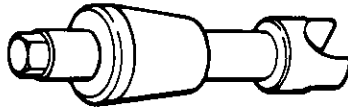

②



③



④



⑤

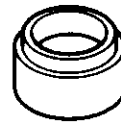

⑥



⑦

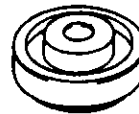

⑧

Differential (Automatic Transmission)



Illustrated Index

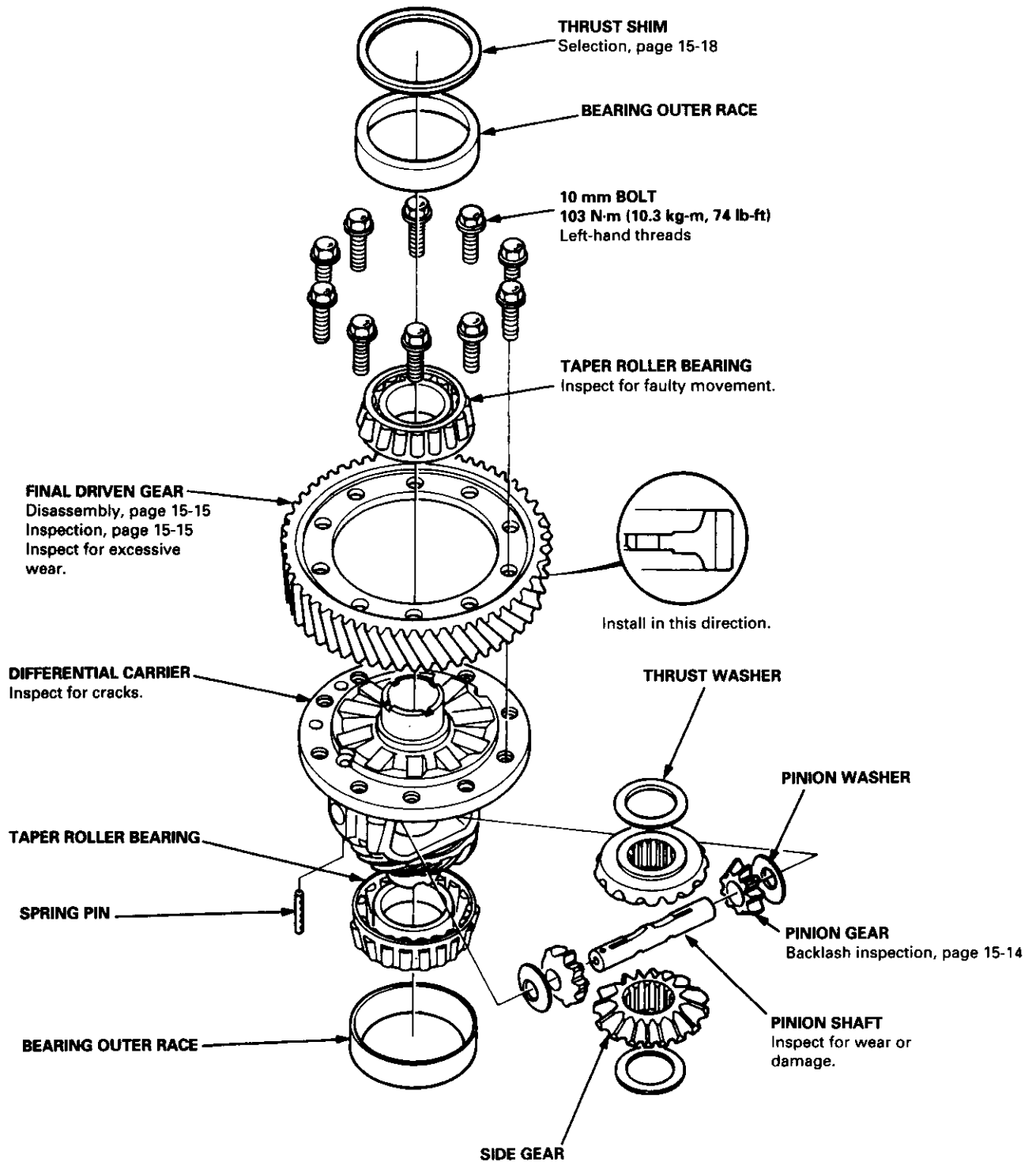

Differential (Automatic Transmission)

Backlash Inspection

1. Place the differential assembly on V-blocks and install both axles.
2. Check backlash of both side gears.

**Standard (New): 0.05 — 0.15 mm
(0.002 — 0.006 in.)**

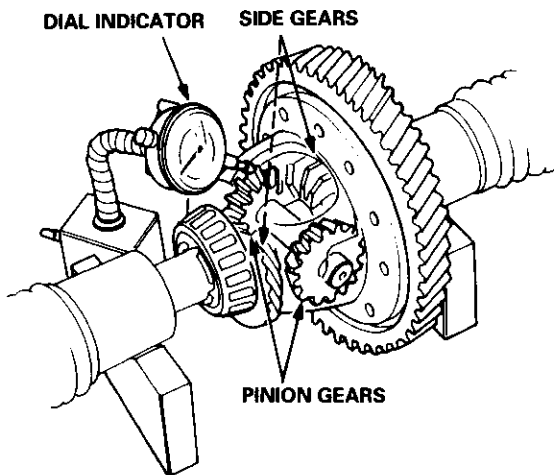

3. If out of tolerance, disassemble the differential and select new pinion washers from the table below.

PINION WASHER

Part Number	Thickness
41351 — PG1 — 000	0.70 mm (0.028 in)
41352 — PG1 — 000	0.75 mm (0.029 in)
41353 — PG1 — 000	0.80 mm (0.031 in)
41354 — PG1 — 000	0.85 mm (0.032 in)
41355 — PG1 — 000	0.90 mm (0.035 in)
41356 — PG1 — 000	0.95 mm (0.036 in)
41357 — PG1 — 000	1.00 mm (0.039 in)
41358 — PG1 — 000	1.05 mm (0.041 in)

Bearing Replacement

NOTE: Check the bearings for wear and rough rotation. If the bearings are OK, removal is not necessary.

1. Remove the taper roller bearings using a bearing puller.

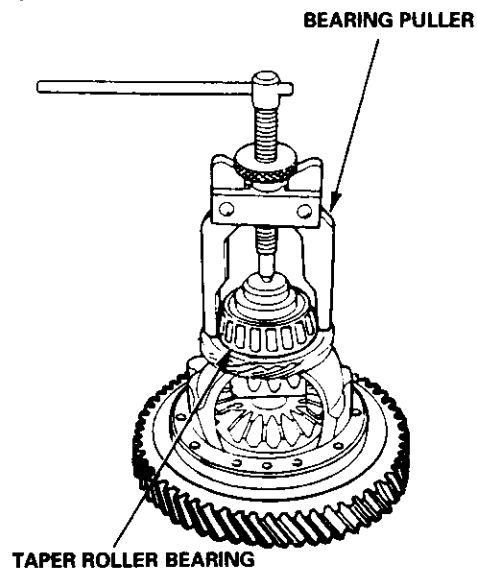

2. Install the new taper roller bearings, using the special tool and a press as shown.

NOTE:

- Drive the bearings on until they bottom.
- Use the special tool:
 - large end for torque converter housing side bearing.
 - small end for transmission housing side bearing.

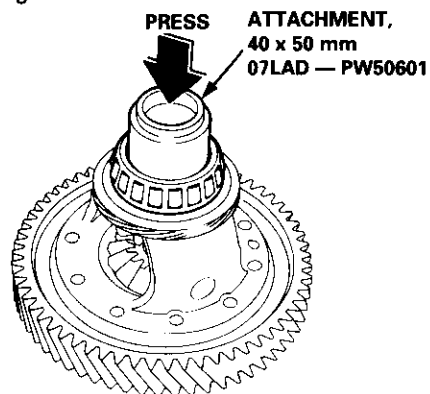

NOTE:

- The bearing and outer race should be replaced as a set.
- Inspect and adjust the bearing preload whenever a bearing is replaced.
- Drive in the bearings securely so that there is no clearance between the bearings and differential carrier.



Inspection/Disassembly

1. Remove the final driven gear and inspect teeth for wear or damage.

NOTE: The final driven gear bolts have left-hand threads.

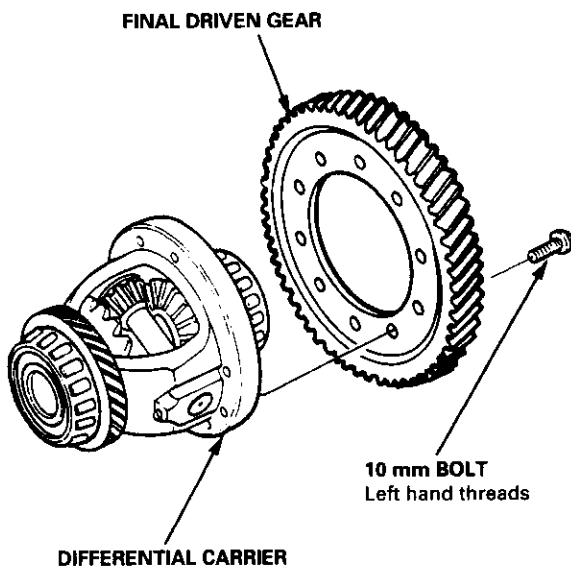

2. Drive out the spring pin with a pin punch.

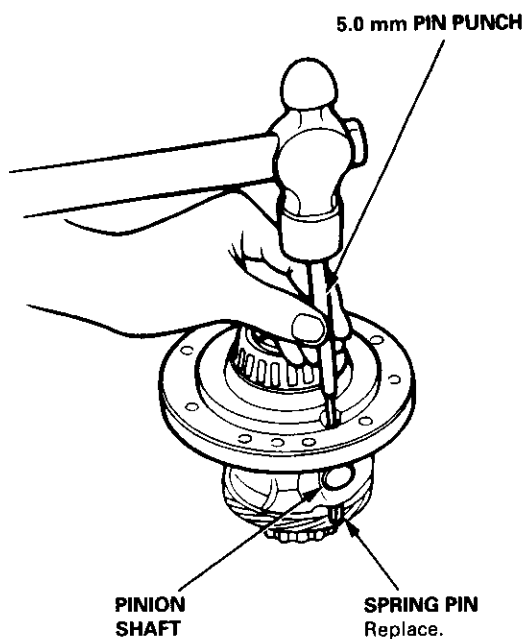

3. Remove the pinion shaft, pinion gears, washers, thrust washers, and side gears.

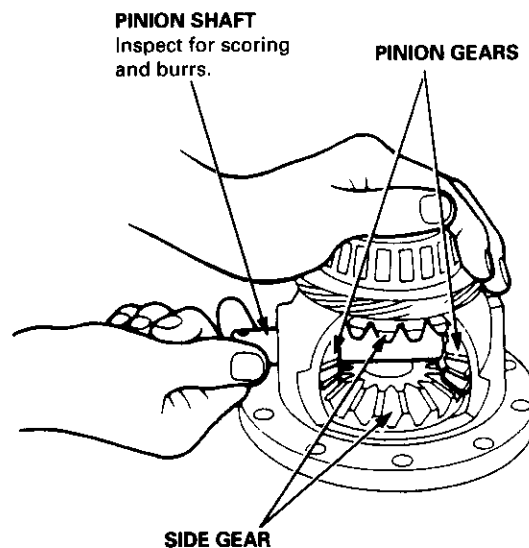

4. Wash the parts thoroughly in solvent and dry them with compressed air. Inspect all parts for wear or damage and replace any that are defective.

Differential (Automatic Transmission)

Reassembly

1. Install the side gears, with thrust washers in the differential carrier.

NOTE: Coat all gears with molybdenum disulfide grease on all sides.

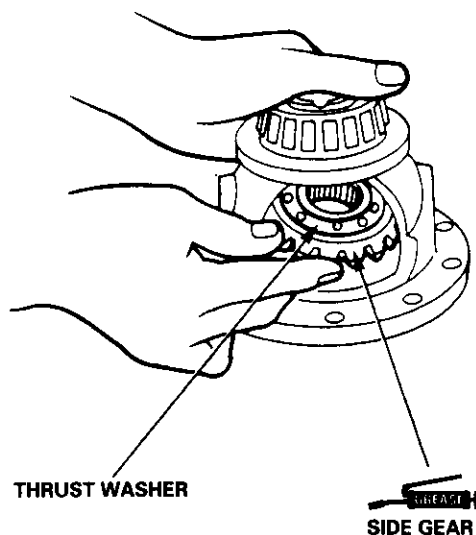

2. Set the pinion gears in the place exactly opposite each other in mesh with side gears, then install a pinion washer behind each one. Washers must be of equal thickness.

NOTE: Select the correct pinion washer from the table on page 15-14.

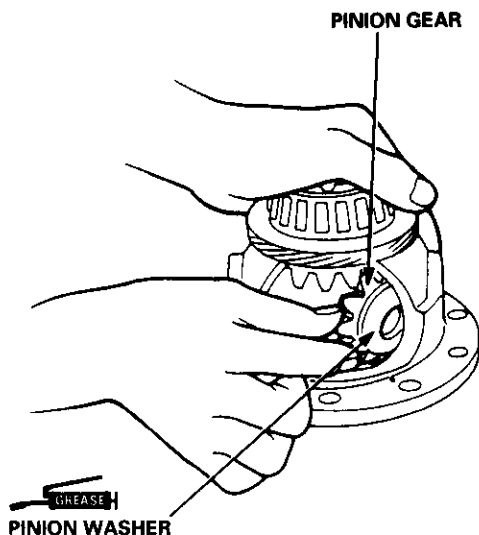

3. Rotate the gears until the shaft holes in the pinion gears line up with the shaft holes in carrier.
4. Insert the pinion shaft and align the spring pin holes in one end with the matching hole in the carrier.

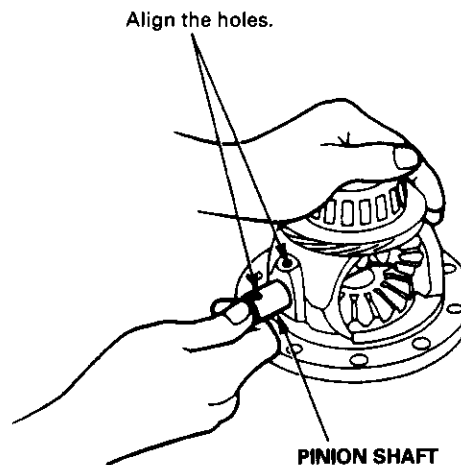

5. Drive in the spring pin with a pin punch.

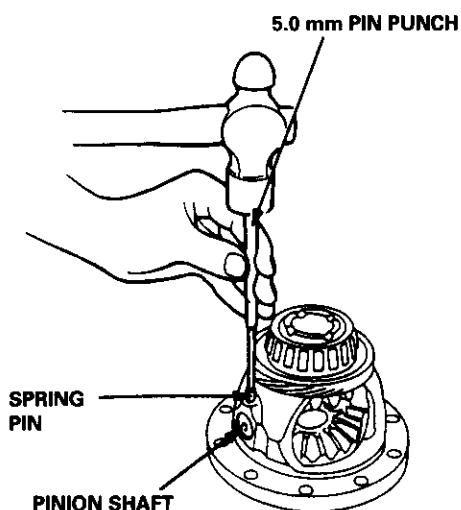

6. Check backlash of both pinion gears again.

Standard (New): 0.05 — 0.15 mm
(0.002 — 0.006 in)

- If still out of tolerance, replace both thrust washers.
- If still out of tolerance, replace the side and pinion gears, and recheck backlash.
- If still out of tolerance, replace the carrier assembly.



7. Install the final driven gear. Torque the bolts to 103 N-m (10.3 kg-m, 74 lb-ft).

NOTE: The final driven gear bolts have left-hand threads.

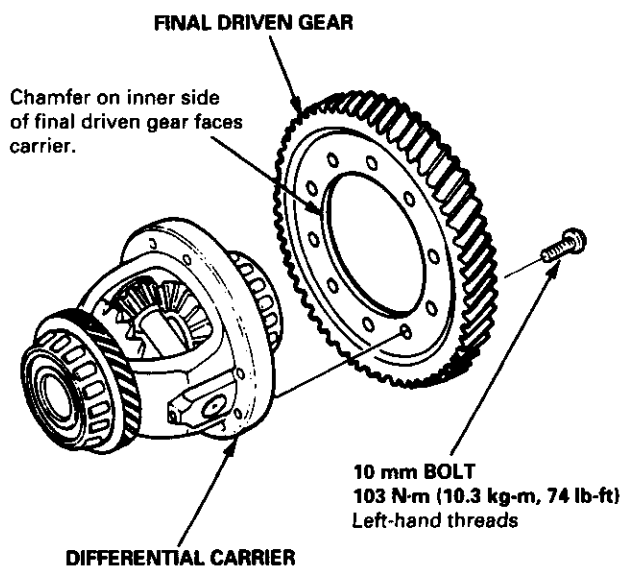

Oil Seal Removal

1. Remove the differential assembly.
2. Remove the oil seal from the transmission housing.

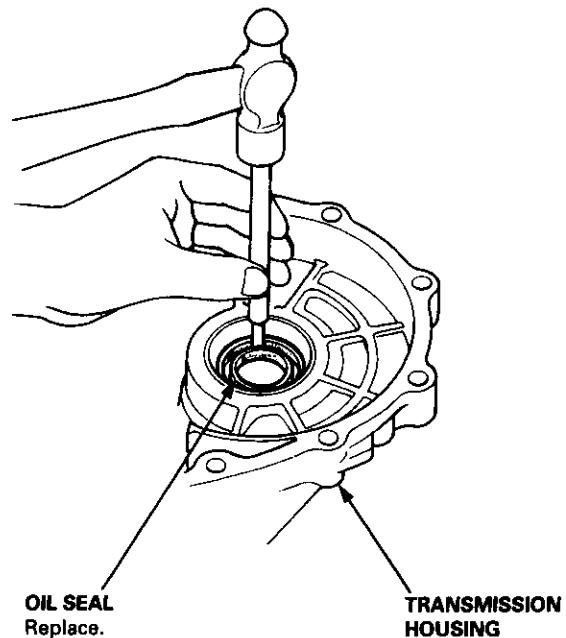

3. Remove the oil seal from the torque converter housing.

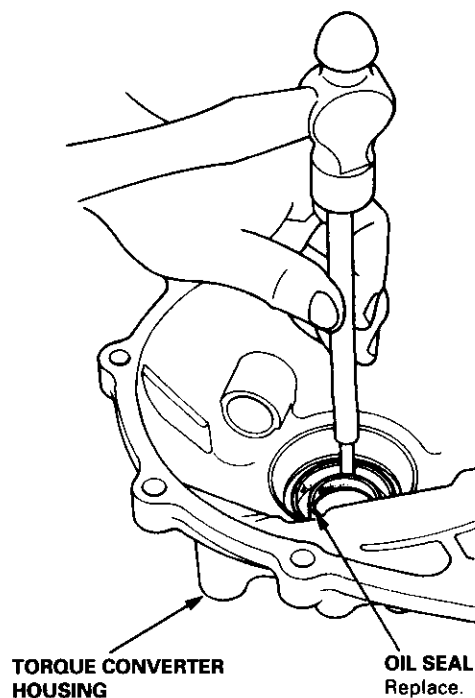

Differential (Automatic Transmission)

Taper Roller Bearing Preload Adjustment

NOTE: If the transmission housing, torque converter housing, differential carrier, taper roller bearing, outer race or thrust shim were replaced, the bearing preload must be adjusted.

1. Remove the bearing outer race and thrust shim from the transmission housing by heating the housing to about 212°F (100°C) with a heat gun.

CAUTION:

- Do not heat the housing in excess of 212°F (100°C).
- Replace the taper roller bearing when the outer race is to be replaced.
- Do not use a shim on the torque converter housing side.

NOTE: Let the transmission housing cool to the room temperature before adjusting the bearing preload.

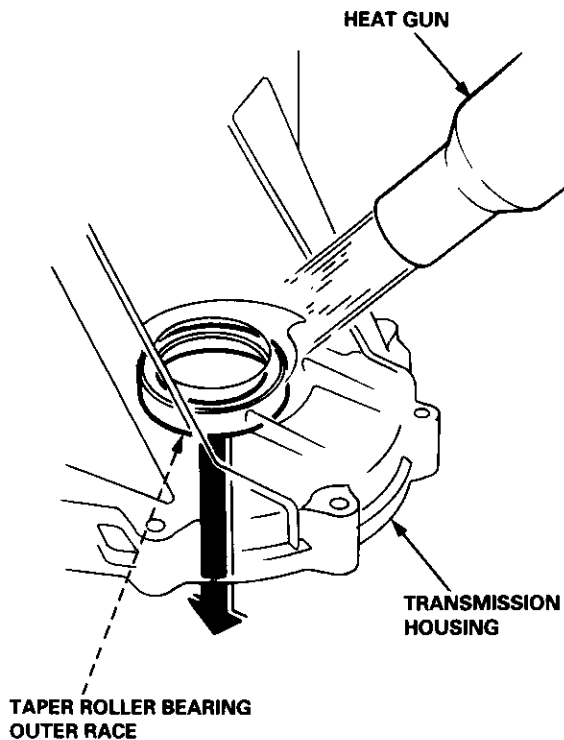

2. Select the thrust shim from the table below so that their total thickness is 2.60 mm (0.102 in).

CAUTION: Do not use more than two shims to adjust the bearing preload.

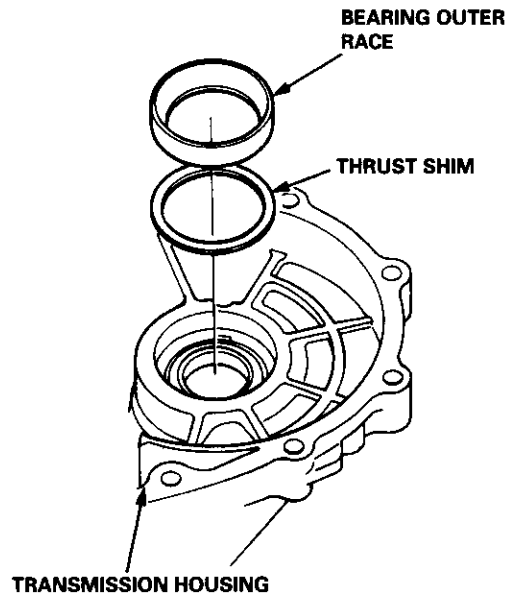

THRUST SHIM

No.	Part Number	Thickness
A	41441 — PK4 — 000	2.20 mm (0.087 in)
B	41442 — PK4 — 000	2.25 mm (0.089 in)
C	41443 — PK4 — 000	2.30 mm (0.091 in)
D	41444 — PK4 — 000	2.35 mm (0.093 in)
E	41445 — PK4 — 000	2.40 mm (0.094 in)
F	41446 — PK4 — 000	2.45 mm (0.096 in)
G	41447 — PK4 — 000	2.50 mm (0.098 in)
H	41448 — PK4 — 000	2.55 mm (0.100 in)
*I	41449 — PK4 — 000	2.60 mm (0.102 in)
J	41450 — PK4 — 000	2.65 mm (0.104 in)
K	41451 — PK4 — 000	2.70 mm (0.106 in)
L	41452 — PK4 — 000	2.75 mm (0.108 in)
M	41453 — PK4 — 000	2.80 mm (0.110 in)
N	41454 — PK4 — 000	2.85 mm (0.112 in)
O	41455 — PK4 — 000	2.90 mm (0.114 in)
P	41456 — PK4 — 000	2.95 mm (0.116 in)
Q	41457 — PK4 — 000	3.00 mm (0.118 in)
R	41458 — PK4 — 000	3.05 mm (0.120 in)

* Standard shim



3. After installing the thrust shim, install the outer race in the transmission housing, using the special tools as shown.

CAUTION:

- Install the outer race squarely in the transmission housing.
- Check that there is no clearance between the outer race, shim and transmission housing.
- Install the gasket when checking preload.

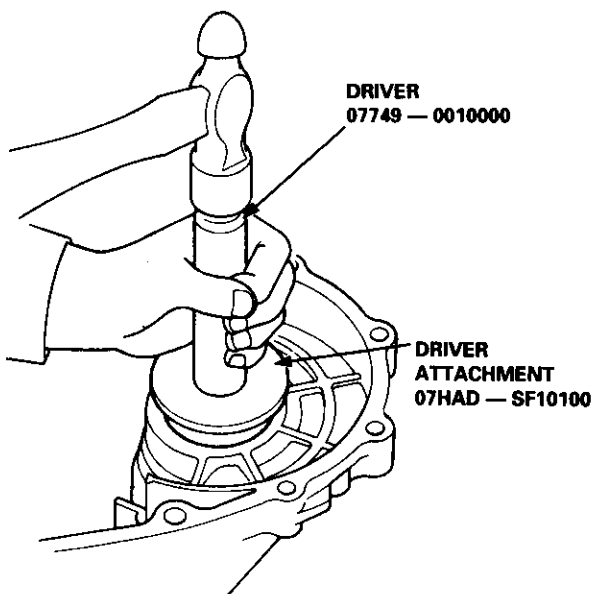

4. With the mainshaft, countershaft and secondary shaft removed, install the differential assembly and torque the transmission housing.

TORQUE: 55 N-m (5.5 kg-m, 40 lb-ft)

5. Rotate the differential assembly in both directions to seat the bearings.

6. Measure the starting torque of the differential assembly with the special tool and a torque wrench.

STANDARD:

New bearings: 2.8 — 4.0 N-m
(28 — 40 kg-cm, 24 — 35 lb-in)

Reused bearings: 2.5 — 3.7 N-m
(25 — 37 kg-cm, 22 — 32 lb-in)

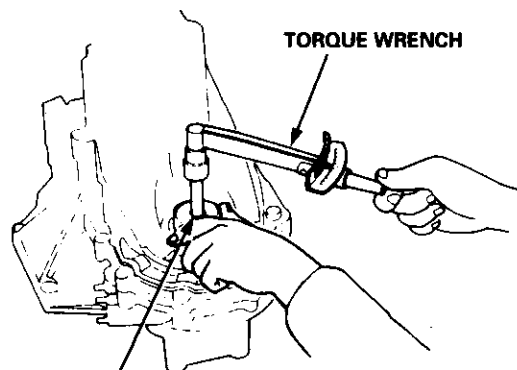

**PRELOAD INSPECTION TOOL
07HAJ — PK40201**

NOTE:

- Measure the starting torque at normal room temperature in both directions.
- If out of spec, select two thrust shims which will give the correct preload, and repeat steps 1 — 6.
- Changing one of the shims to the next size will increase or decrease starting torque about 3 — 4 kg-cm (2.60 — 3.47 lb-in).
- To increase the starting torque, increase the thickness of shims. To decrease the starting torque, decrease the thickness of shims.

Differential (Automatic Transmission)

Bearing Outer Race Replacement

1. Remove the bearing outer race from the torque converter housing by heating the housing to about 212°F (100°C) with a heat gun.

CAUTION: Do not heat the housing in excess of 212°F (100°C).

NOTE:

- Replace the bearing with a new one whenever the outer race is to be replaced.
- Do not use shims on the torque converter housing side.
- Adjust preload after replacing the bearing outer race and bearing.

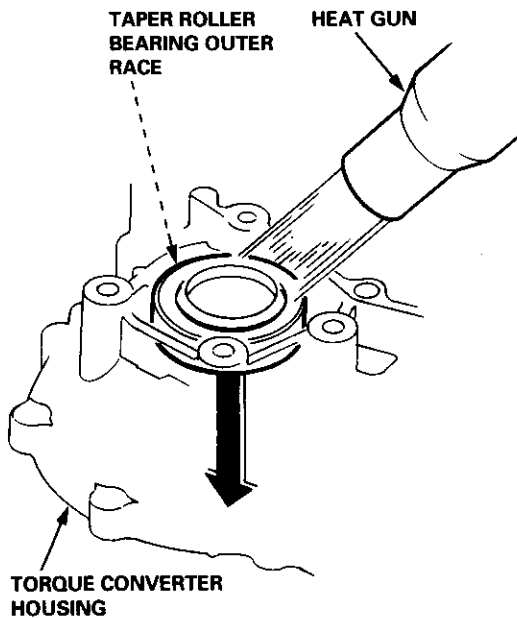

2. Install the new bearing outer race flush with the housing using the special tools.

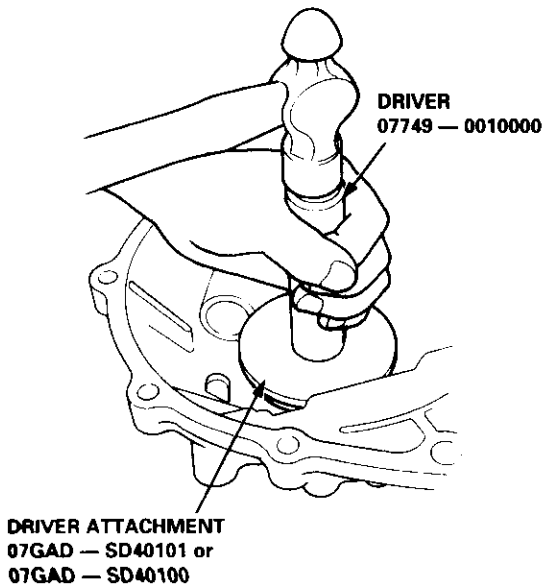

Oil Seal Installation

1. Install the oil seal in the transmission housing, using the special tools as shown.

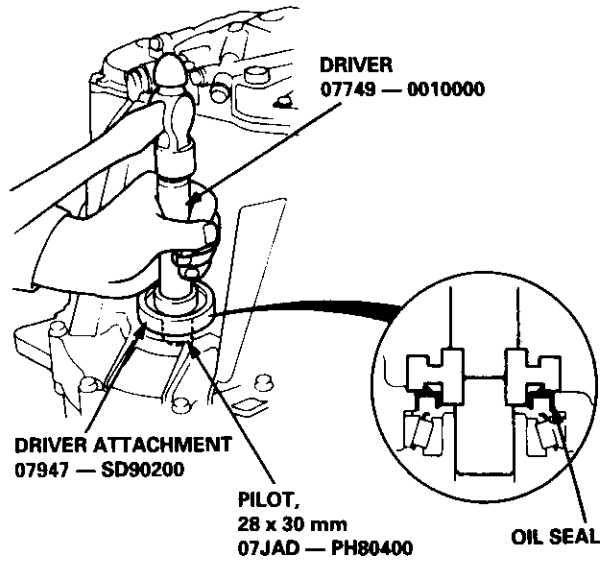

2. Drive the oil seal into the torque converter housing, using the special tools as shown.

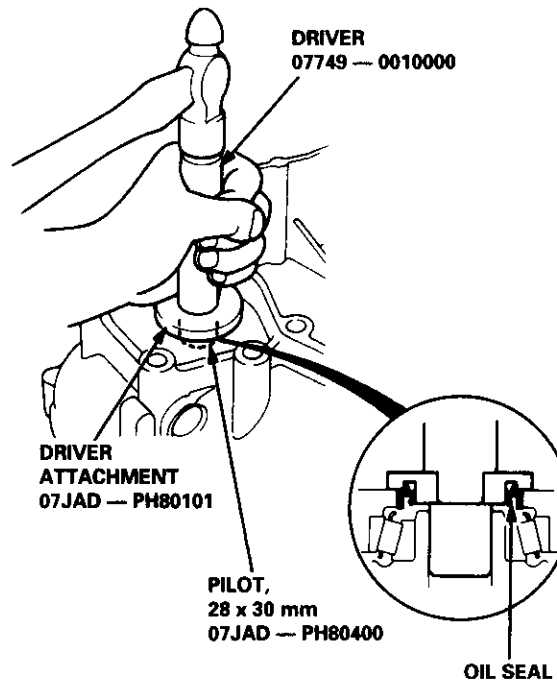

Driveshafts

Special Tools	16-2
Driveshafts	
Removal	16-3
Disassembly	16-5
Disassembly/Inspection	16-6
Reassembly	16-7
Installation	16-9
Intermediate Shaft	
Replacement	16-11
Disassembly	16-12
Disassembly/Inspection	16-13
Reassembly	16-14



Special Tools

Ref. No.	Tool Number	Description	Qty	Page Reference
①	07GAD-PH70201	Oil Seal Driver	1	16-14
②	07GAF-SD40700	Hub Dis/Assembly Base	2	16-12, 14
③	07MAC-SL00100	Ball Joint Remover, 32 mm	1	16-3
④	07746-0010200	Attachment, 37 x 40 mm	1	16-12
⑤	07746-0010400	Attachment, 52 x 55 mm	1	16-14
⑥	07746-0030400	Attachment, 35 mm I.D.	1	16-14
⑦	07749-0010000	Driver	1	16-12, 14

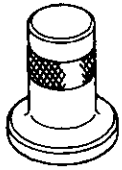

①

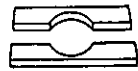

②

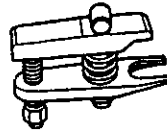

③



④

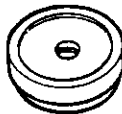

⑤



⑥

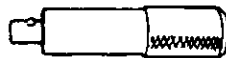

⑦

Driveshafts



Removal

INSPECTION

Driveshaft Boot

Check the boots on the driveshaft for cracks, damage, leaking grease or loose boot bands. If any damage is found, replace the boot.

Spline Looseness

Turn the driveshaft by hand and make sure the spline and joint are not excessively loose. If damage is found, replace the inboard joint.

Twisted or Cracked

Make sure the driveshaft is not twisted or cracked. Replace if necessary.

1. Raise the car and place safety stands in the proper locations (see section 1).
2. Remove the front wheels.
3. Drain the transmission oil or fluid.
4. Raise the locking tab on the spindle nut and remove it.

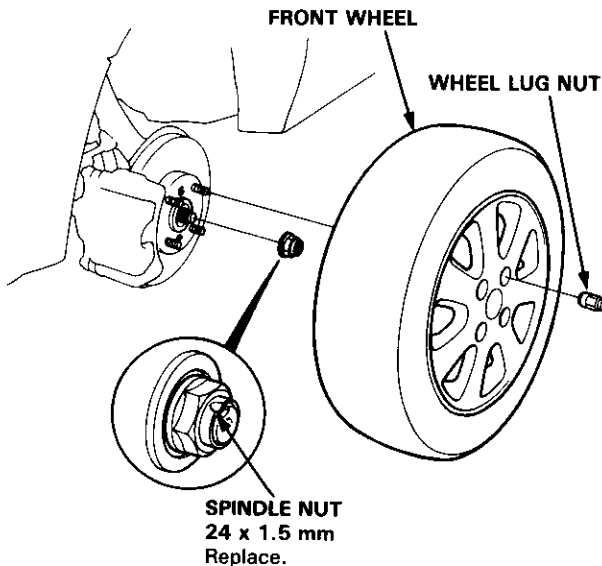

5. Remove the damper fork nut, bolt and damper pinch bolt.

6. Remove the damper fork.

DAMPER PINCH BOLT (SELF-LOCKING BOLT)
10 x 1.25 mm

DAMPER FORK

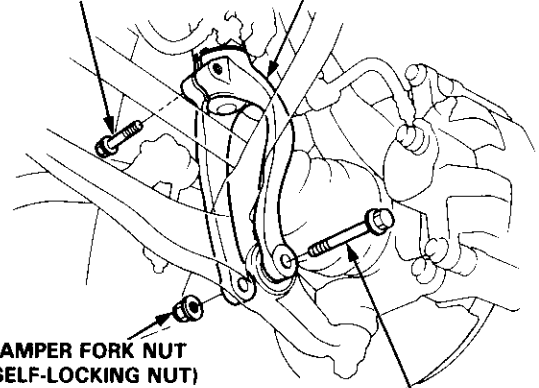

DAMPER FORK NUT (SELF-LOCKING NUT)
12 x 1.25 mm
Replace.

DAMPER FORK BOLT

7. Remove the cotter pin from the lower arm ball joint castle nut and remove the nut.

8. Install a 14 mm hex nut on the ball joint. Be sure that the 14 mm hex nut is flush with the ball joint pin end, or the threaded section of the ball joint pin might be damaged by the ball joint remover.

9. Use the ball joint remover, 32 mm as shown on page 18-13 to separate the ball joint and lower arm.

10. Position the special tool between the knuckle and lower arm as shown, then separate the lower arm.

CAUTION: Be careful not to damage the ball joint boot.

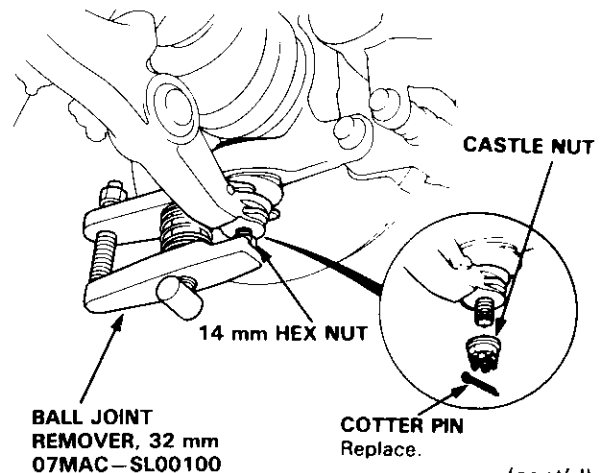

(cont'd)

Driveshafts

Removal (cont'd)

11. Pry the driveshaft assembly with a screwdriver as shown to force the set ring at the driveshaft end past the groove.

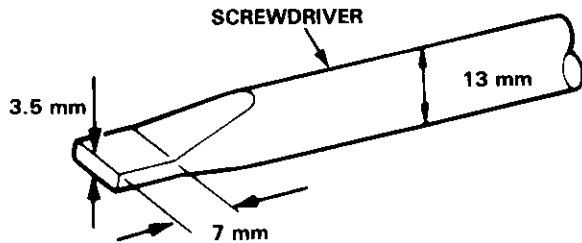

12. Pull the inboard joint and remove the driveshaft and CV joint from the differential case as an assembly.

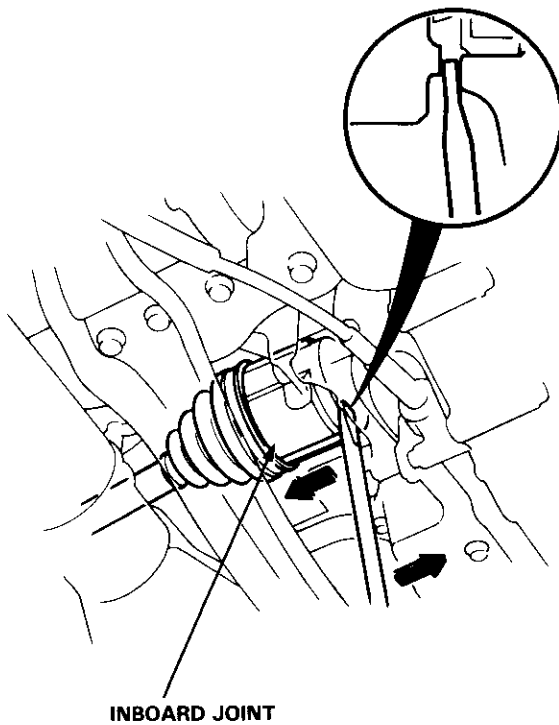

- With Intermediate Shaft:
Remove the left driveshaft from the bearing support by tapping the inboard joint of the driveshaft with a plastic hammer.

CAUTION:

- Do not pull on the driveshaft, as the CV joint may come apart.
- Use care when prying out the assembly and pull it straight to avoid damaging the differential oil seal.

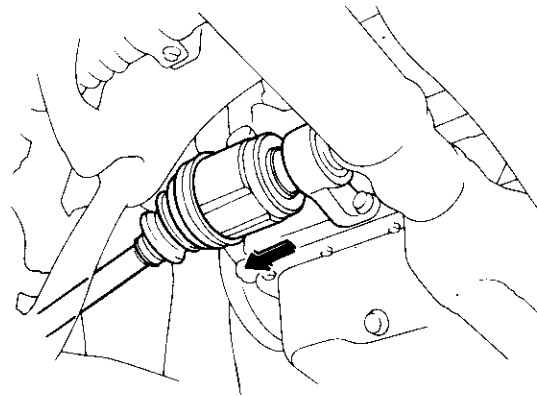

13. Pull the knuckle outward and remove the driveshaft outboard joint from the front wheel hub using a plastic hammer.

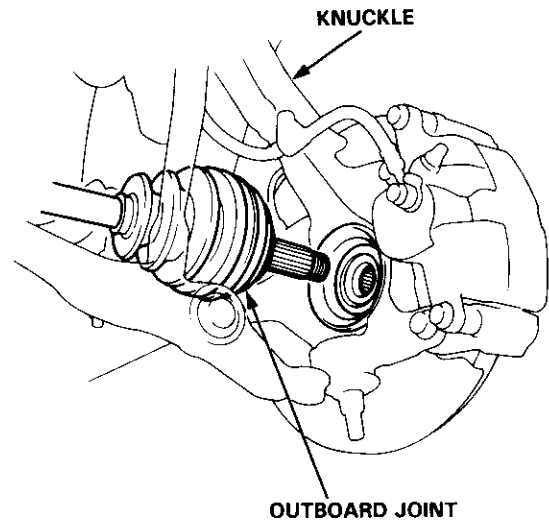



Disassembly

CAUTION: Do not try to disassemble the outboard joint.

1. To remove the boot band, pry up the locking tabs with a screwdriver and raise the end of the band.

CAUTION: Take care not to damage the boots.

NOTE: Carefully clamp the driveshaft in a vise with soft jaws.

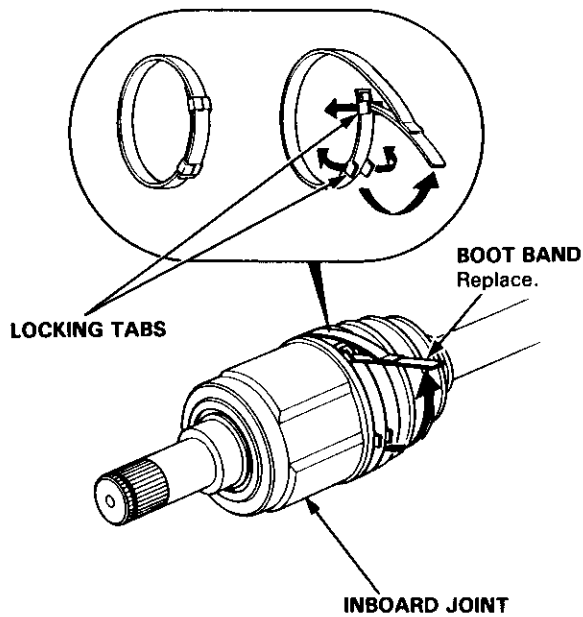

2. Remove the inboard joint and rollers.
3. Remove the circlip, then remove the spider using a commercially available bearing remover.

NOTE: Before disassembly, mark the spider and driveshaft so they can be reinstalled in their original positions.

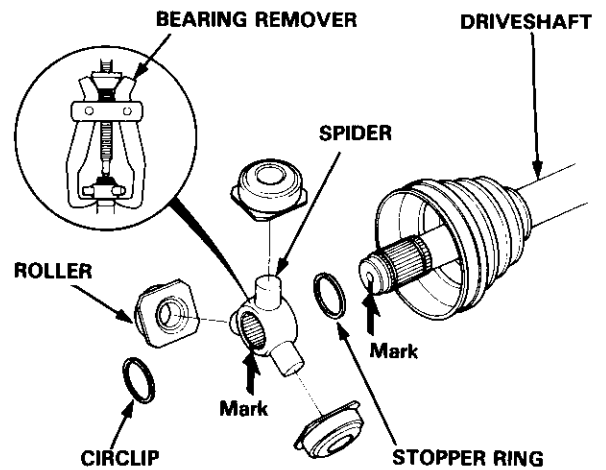

Driveshafts

Disassembly/Inspection

NOTE:

- Mark the rollers and roller grooves during disassembly to ensure proper positioning during reassembly.
- Before disassembly, mark the spider and driveshaft so they can be reinstalled in their original positions.
- The inboard joint must be removed to replace the boots.
- If the boot band is the welded type, cut off as shown.

CAUTION: Take care not to damage the boots.

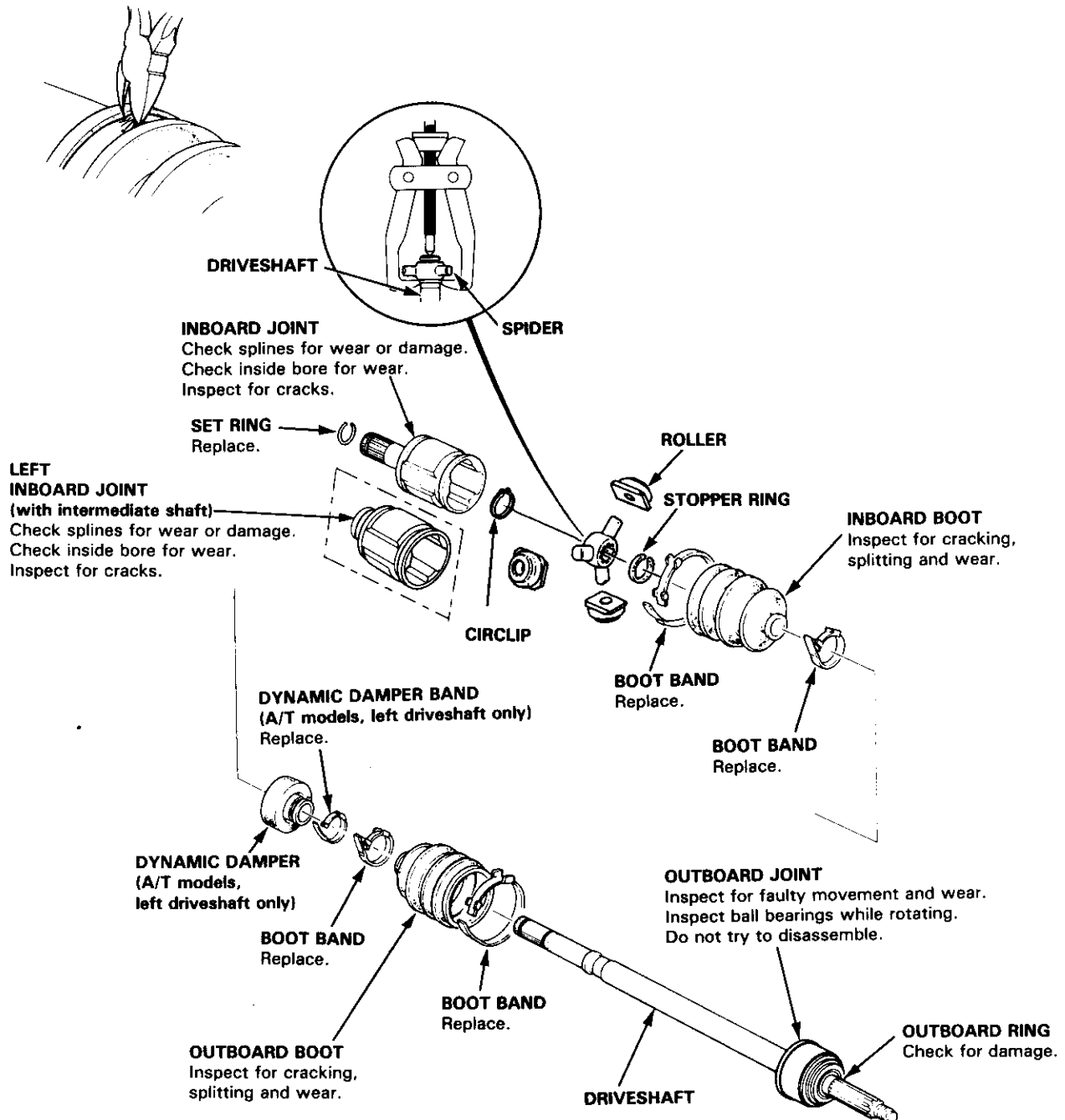



Reassembly

NOTE: Clean the driveshafts before reassembly.

1. Wrap the splines with vinyl tape to prevent damage to the boots and dynamic damper (A/T models, left driveshaft only).
2. Install the outboard boot, dynamic damper and inboard boot to the driveshaft, then remove the vinyl tape.

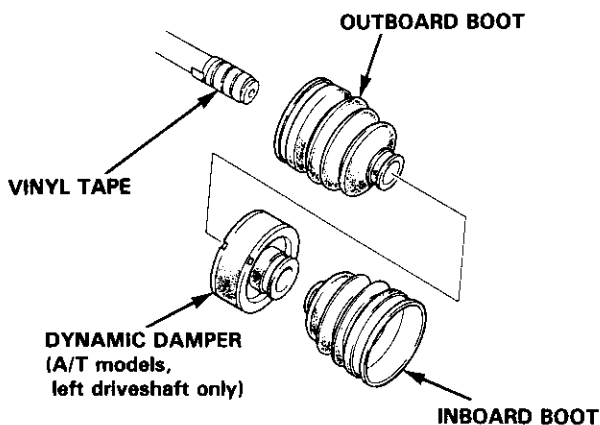

3. Install the stopper ring into the driveshaft groove. Rotate the stopper ring in its groove to be sure it is fully seated.
4. Install the spider on the driveshaft by aligning the marks on the spider and end of the driveshaft.
5. Fit the circlip into the driveshaft groove. Rotate the circlip in its groove to be sure it is fully seated.

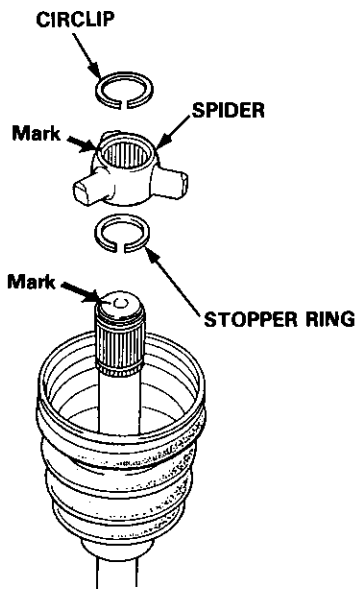

6. Pack the outboard joint with the joint grease included in the new driveshaft set.

Grease Quantity. 130–140 g (4.6–4.9 oz)

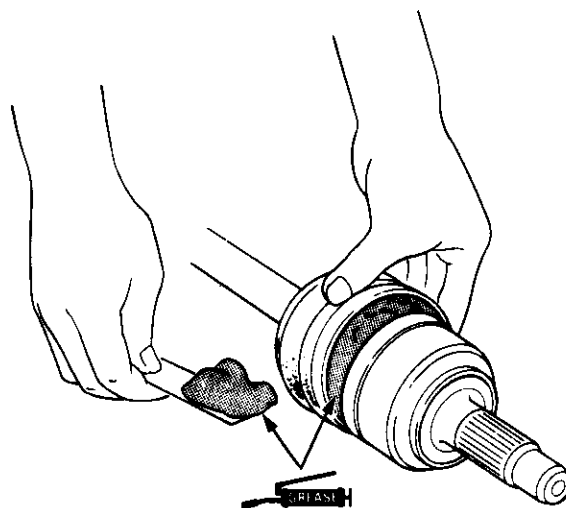

7. Fit the rollers to the spider with their high shoulders facing outward.

CAUTION:

- Reinstall the rollers in their original positions on the spider.
- To prevent it from falling off, hold the driveshaft assembly so the spider and roller point up.

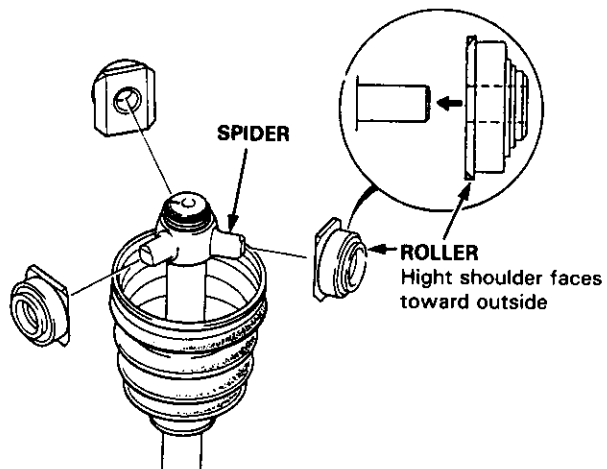

(cont'd)

Driveshafts

Reassembly (cont'd)

8. Pack the inboard joint with the joint grease included in the new driveshaft set.

Grease Quantity: 130–140 g (4.6–4.9 oz)

A/T models, Left driveshaft:

120–130 g (4.2–4.6 oz)

9. Fit the inboard joint onto the driveshaft.

CAUTION: To prevent it from falling off, hold the driveshaft assembly so the inboard joint points up.

Manual Transmission Only:
Align the holder direction of the rollers toward the slot of inboard joint as shown below.

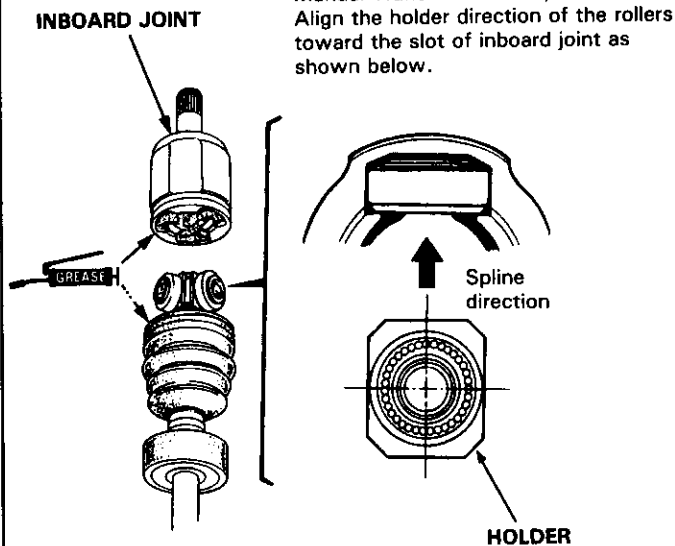

10. Adjust the length of the driveshafts to the figure below, then adjust the boots to halfway between full compression and full extension.

NOTE: The ends of boots seat in the groove of the driveshaft and joint.

Right: 507.9–512.9 mm (20.00–20.19 in)

Left:

- A/T models

862.9–867.9 mm (33.97–34.17 in)

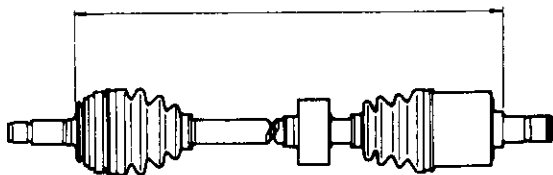

- M/T models

520.9–525.9 mm (20.50–20.70 in)

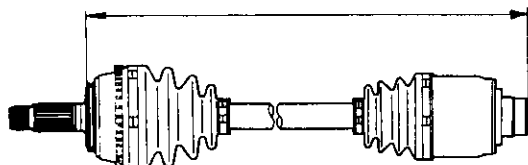

11. Install new boot bands on the boot and bend both sets of locking tabs.

12. Lightly tap on the doubled-over portions to reduce their height.

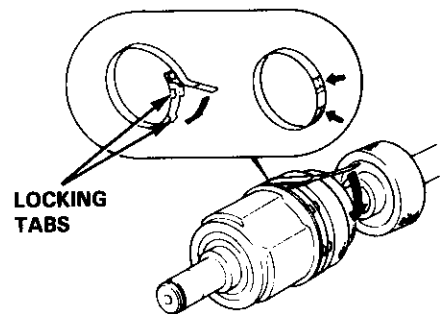

13. Position the dynamic damper as shown below.

- Install a new dynamic damper band and bend down both sets of locking tabs.
- Lightly tap on the doubled-over portion of the band to reduce its height.

DYNAMIC DAMPER

175 ± 2 mm (6.9 ± 0.1 in)

DYNAMIC DAMPER BAND

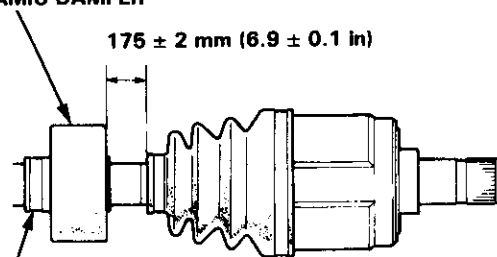



Installation

1. Install the outboard joint in the knuckle, then loosely install the spindle nut.
2. Apply 1.0–1.5 g (0.04–0.05 oz) of specified grease to the whole spline surface of the intermediate shaft.

NOTE: After applying grease, remove the grease from the spline grooves at intervals of 2-3 splines and from the set ring groove so air can bleed from the inboard joint.

3. Install the new set ring onto the driveshaft or intermediate shaft groove.

CAUTION: Always use a new set ring whenever the driveshaft is being installed.

4. Install the inboard end of the driveshaft into the differential or intermediate shaft.

NOTE: After applying grease, remove the grease from the spline grooves at intervals of 2-3 splines and from the set ring groove.

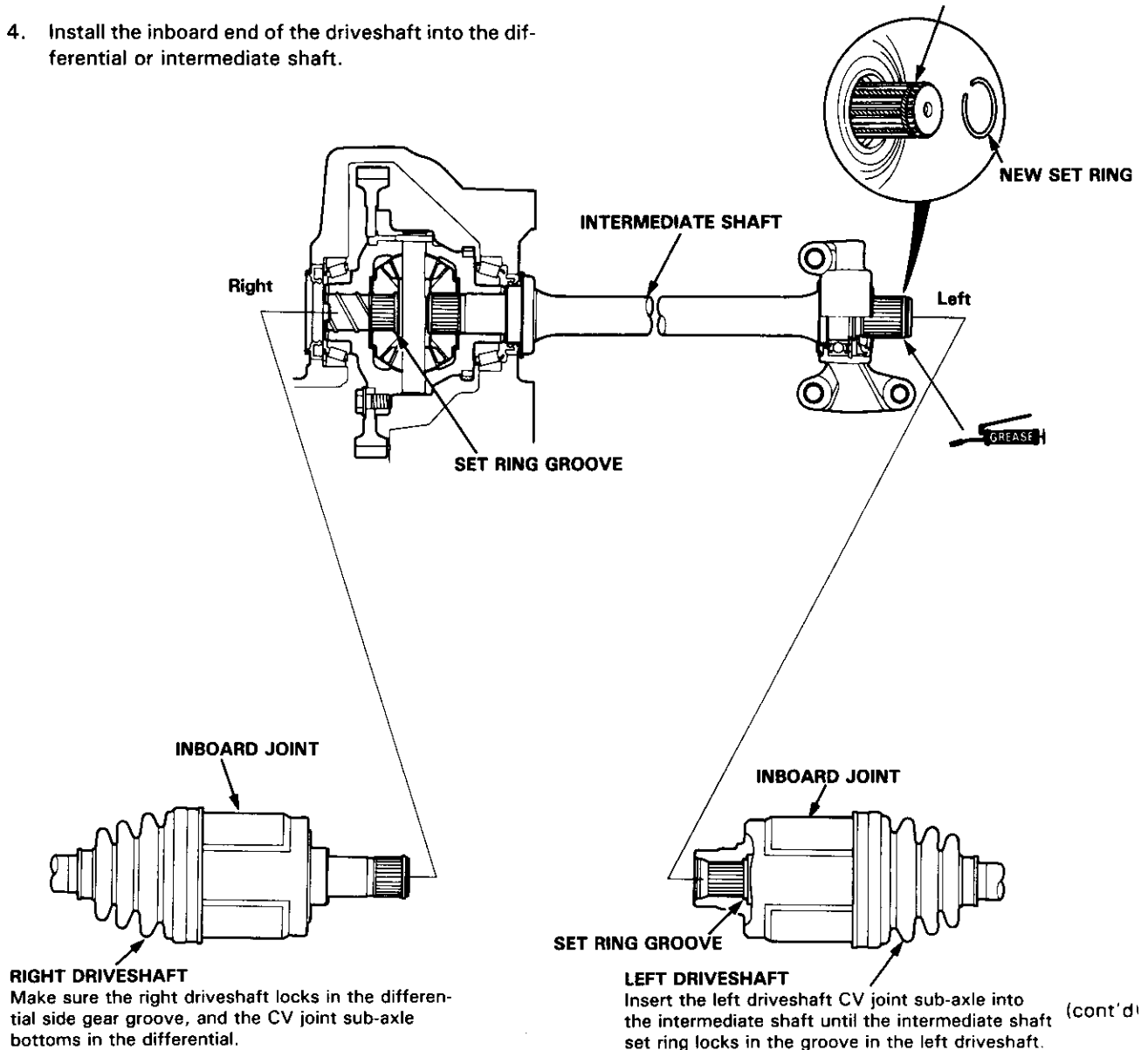

(cont'd)

Driveshafts

Installation (cont'd)

5. Install the damper fork over the driveshaft and onto the lower arm. Install the damper in the damper fork so the aligning tab is aligned with the slot in the damper fork.
6. Loosely install the damper pinch bolt, and the new damper fork nut and bolt.

NOTE: The bolts and nut should be tightened with the vehicle's weight on the damper.

**DAMPER PINCH BOLT
(SELF-LOCKING BOLT)**
10 x 1.25 mm
44 N·m (4.4 kg-m, 32 lb-ft)

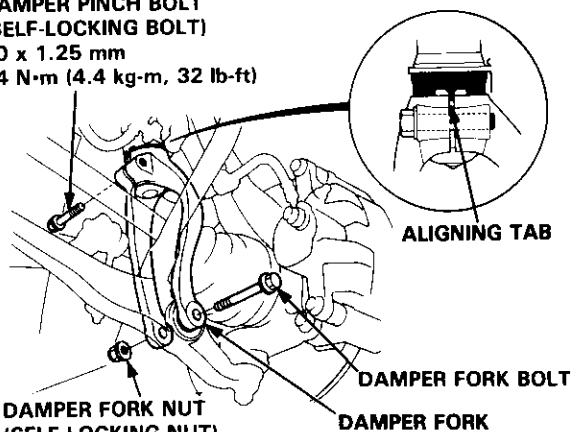

**DAMPER FORK NUT
(SELF-LOCKING NUT)**
12 x 1.25 mm
65 N·m (6.5 kg-m, 47 lb-ft)

DAMPER FORK BOLT
DAMPER FORK

7. Install the knuckle on the lower arm, then tighten the castle nut and install new cotter pin.

CAUTION:

- Be careful not to damage the ball joint boot.
- Torque the castle nut to the lower torque specification, then tighten it only far enough to align the slot with the pin hole. Do not align the nut by loosening.

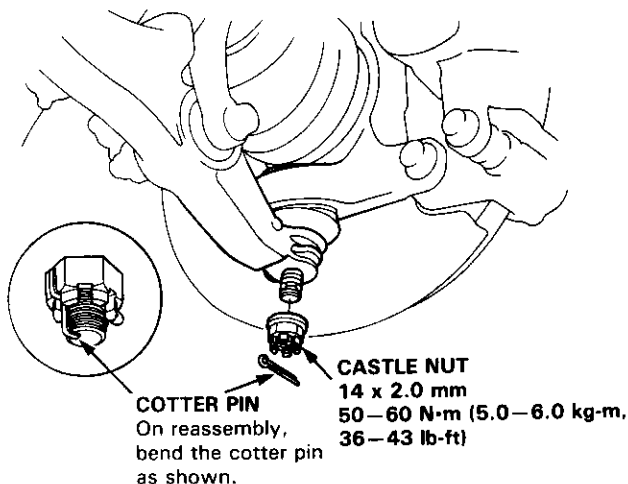

COTTER PIN
On reassembly,
bend the cotter pin
as shown.

CASTLE NUT
14 x 2.0 mm
50-60 N·m (5.0-6.0 kg-m,
36-43 lb-ft)

8. Tighten the new spindle nut.
9. Install the wheels with the wheel lug nuts.

NOTE: Before installing the wheel, clean the mating surface of the brake disc and inside of the wheel.

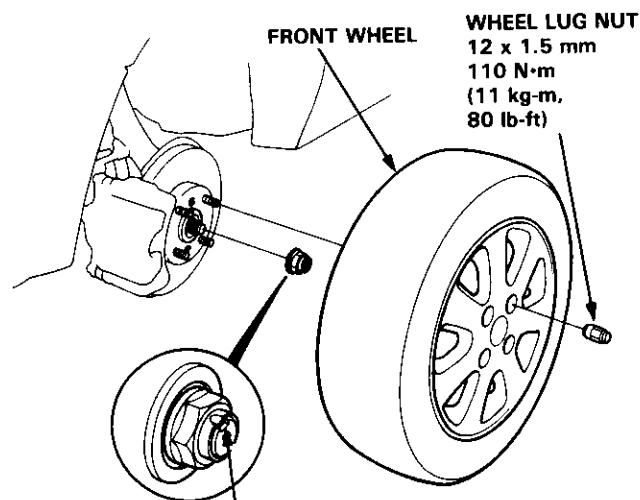

FRONT WHEEL

WHEEL LUG NUT
12 x 1.5 mm
110 N·m
(11 kg-m,
80 lb-ft)

SPINDLE NUT 24 x 1.5 mm
250 N·m (25 kg-m, 181 lb-ft)
NOTE: After tightening, use a drift
to stake spindle nut shoulder
against the driveshaft.

10. Tighten the damper pinch bolt and the new damper fork nut with the vehicle's weight on the damper.
11. Refill the transmission with recommended oil or fluid.
12. Check the front wheel alignment and adjust if necessary (see page 18-4).



Intermediate Shaft

Replacement

1. Drain the transmission oil or fluid.
2. Remove the left driveshaft assembly (see page 16-4).
3. Remove the flange bolt and hex bolts.

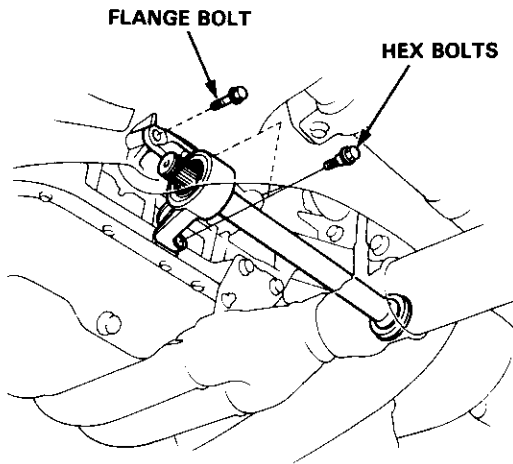

4. Remove the intermediate shaft assembly from the differential.

CAUTION: To prevent damage to the differential oil seal, hold the intermediate shaft horizontal until it is clear of the differential.

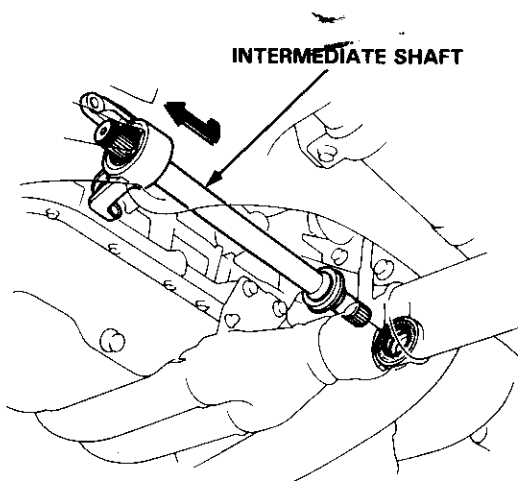

5. Install in the reverse order of removal.

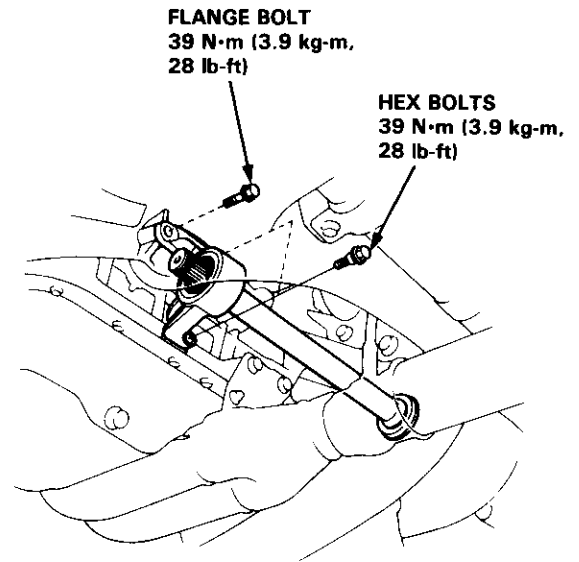

Intermediate Shaft

Disassembly

NOTE: Be careful not to damage the metal rings on the intermediate shaft during disassembly.

1. Remove the set ring.
2. Remove the intermediate shaft outer seal from the bearing support.
3. Remove the external circlip.

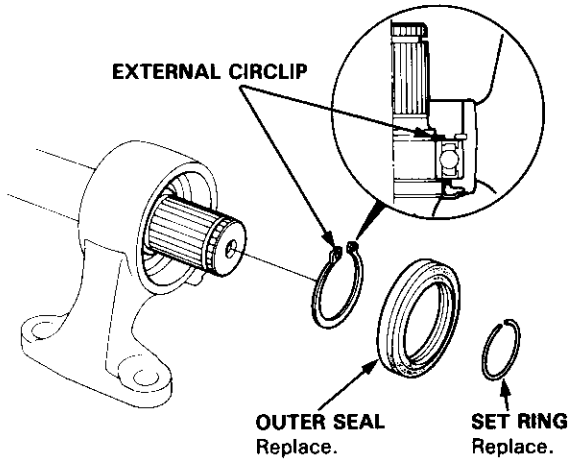

4. Press the intermediate shaft out to the shaft bearing using the special tools and a press.

NOTE: Position the special tools so they do not damage the metal ring on the shaft.

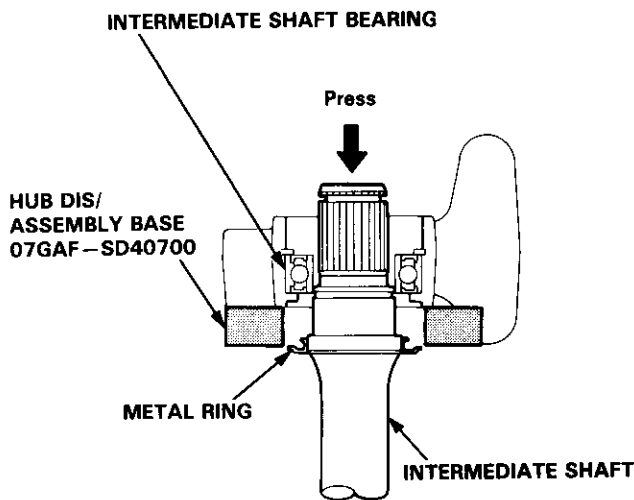

5. Remove the internal circlip.

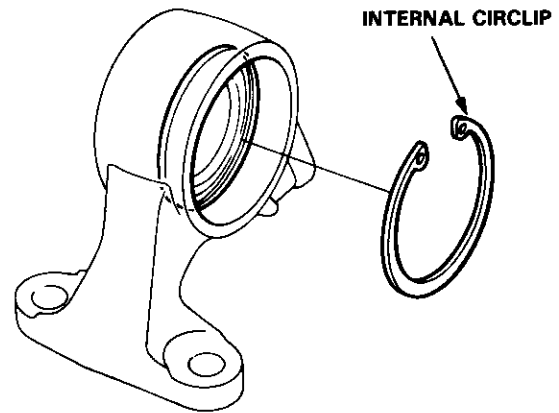

6. Press the intermediate shaft bearing out of the bearing support using the special tools and a press.

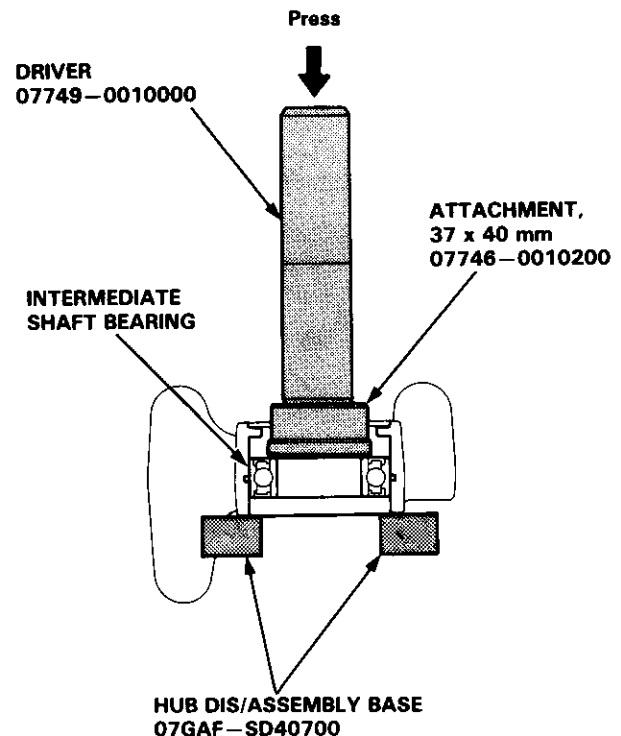



Disassembly/Inspection

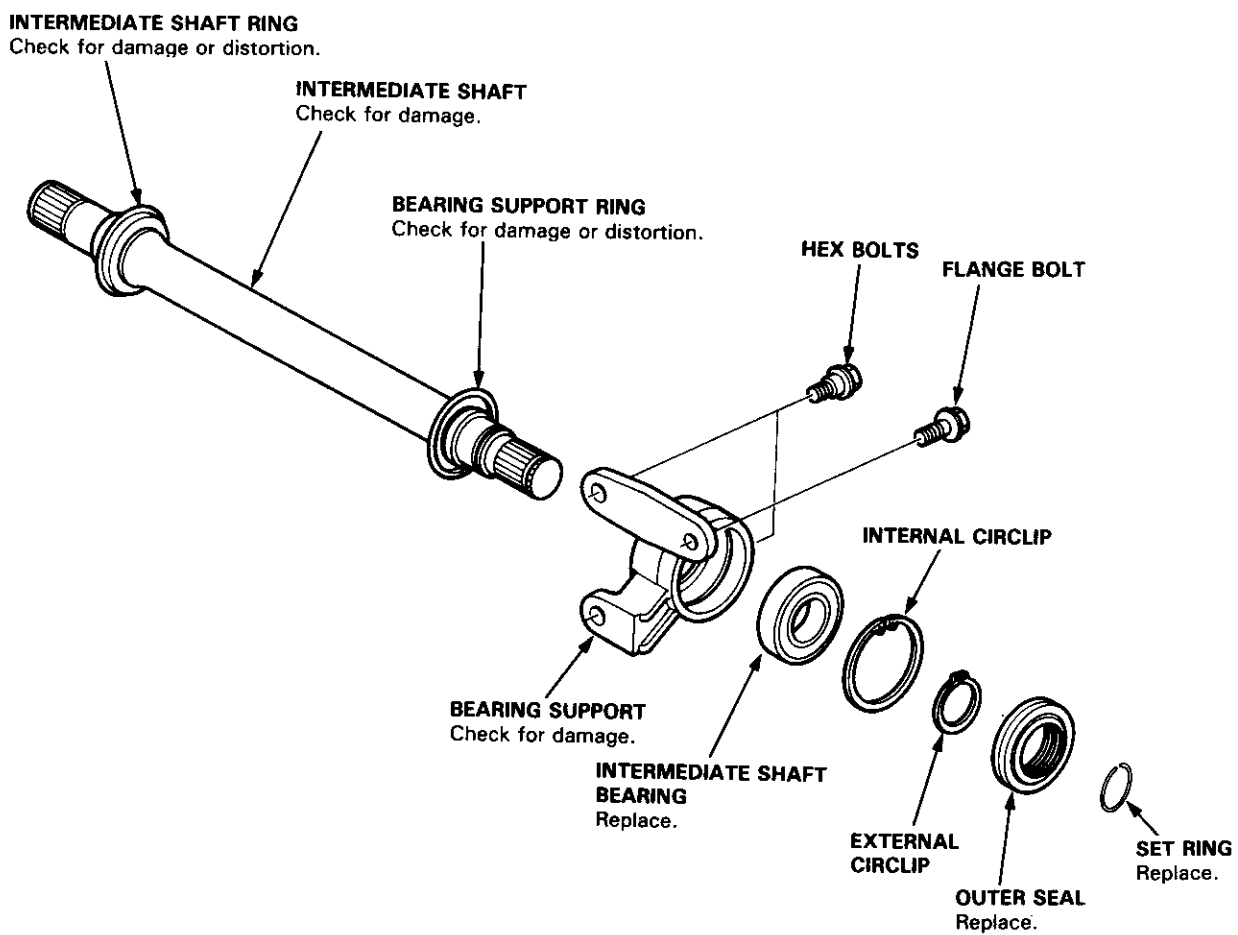

Intermediate Shaft

Reassembly

NOTE: Be careful not to damage the metal rings on the intermediate shaft during reassembly.

1. Press the intermediate shaft bearing into the bearing support using the special tools and a press.

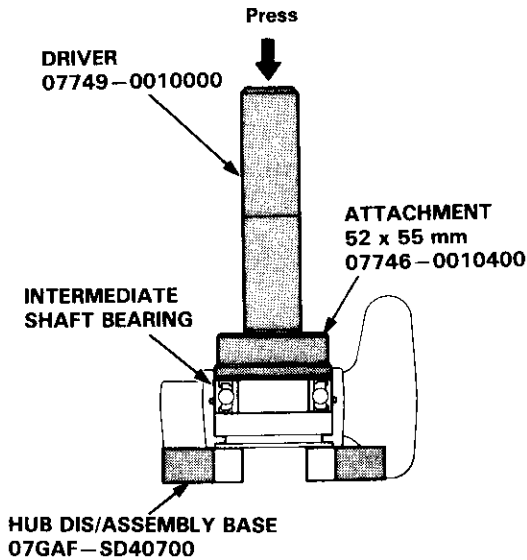

2. Seat the internal circlip in the groove of the bearing support.
3. Press the intermediate shaft into the shaft bearing using the special tool and a press.

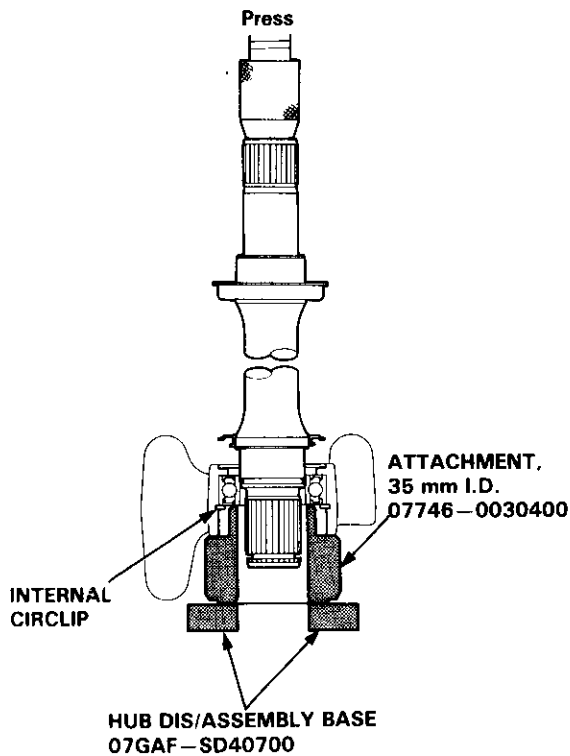

4. Seat the external circlip in the groove of the intermediate shaft.

CAUTION: Install the circlip with the tapered end facing out.

5. Press the outer seal into the bearing support using the special tools and a press.

CAUTION: Do not damage the lip on outer seal during installation.

NOTE: Press the seal flush with the bearing support.

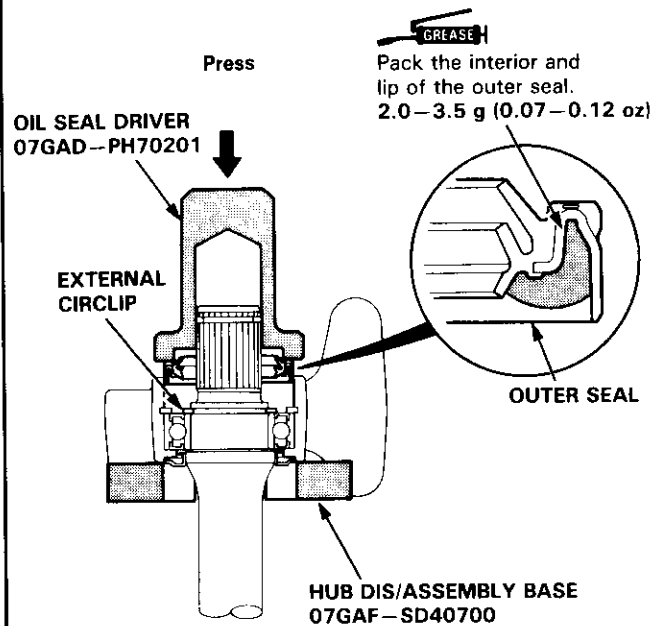

6. Install the new set ring in the intermediate shaft groove.

Steering

Special Tools	17-2	Power Assist Check	
General Information		with Car Parked	17-79
4WS Service Information	17-3	Assist Check at Road Speed	17-80
Component Location		Power Steering Speed Sensor	
Index (2WS/4WS)	17-5	Replacement	17-80
Component Location		Steering Wheel	
Index (4WS)	17-6	Removal	17-81
System Description		Disassembly/Reassembly	17-83
Fluid Flow Diagram	17-7	Installation	
Steering Pump	17-8	2WS	17-84
Fluid Reservoir/Filter	17-9	4WS	17-86
4-way Valve	17-10	Steering Column	
Full-lock Unloader System	17-12	Removal	17-89
Power Steering Speed Sensor	17-12	Inspection	17-92
Electronically Controlled		Installation	17-93
Power Assisted 4WS	17-15	Steering Pump	
Troubleshooting (Power Steering		Replacement	17-96
System)		Pulley Replacement	17-96
General Troubleshooting	17-25	Flow Control Valve Inspection	
Noise and Vibration	17-28	and Replacement	17-97
Fluid Leaks	17-29	Disassembly	17-99
Troubleshooting (4WS)		Illustrated Index	17-102
Component Location	17-30	Assembly	17-103
Connector Locations	17-31	Steering Gearbox	
Circuit Diagram	17-32	Index	17-105
4WS CONTROL UNIT Terminal		Valve Body Unit	17-106
Arrangement	17-34	Gearbox Removal	17-114
Diagnostic Trouble Code (DTC)	17-36	Illustrated Index	17-117
Precautions	17-37	Overhaul	17-118
Symptom-to-System Chart	17-38	Installation	17-134
4WS Indicator Light Circuit	17-42	Rear Steering Actuator (4WS)	
Diagnostic Trouble Codes (DTCs):		Illustrated Index	17-137
10, 12, 16	17-45	Removal	17-138
Diagnostic Trouble Codes (DTCs):		Disassembly	17-140
11, 13, 17	17-50	Assembly	17-141
Diagnostic Trouble Codes (DTCs):		Installation	17-144
20, 22, 24, 28	17-55	4WS Control Unit	
Diagnostic Trouble Codes (DTCs):		Removal and Installation	17-145
21, 23, 25, 29	17-59	Tie-rod End Boot	
Diagnostic Trouble Codes (DTCs):		Replacement	17-145
30, 34	17-63	4WS System Inspection	
Diagnostic Trouble Codes (DTCs):		Electronic Neutral Check	17-146
31, 35	17-64	4WS System Adjustment	
Diagnostic Trouble Codes (DTCs):		4WS System Adjustment	17-151
32, 36	17-66	Sub Steering Angle Sensor	
Diagnostic Trouble Code (DTC): 33	17-68	Adjustment	17-153
Diagnostic Trouble Code (DTC): 50	17-70	Maintenance	
Diagnostic Trouble Code (DTC): 51	17-71	Pump Belt Adjustment	17-74
Diagnostic Trouble Codes (DTCs):		On-Car Checks	
60, 61, 62, 63	17-71	Rack Guide Adjustment	17-75
Maintenance		Fluid Replacement	17-77
Pump Belt Adjustment	17-74	Pump Pressure Check	17-78
On-Car Checks		Steering Wheel Rotational Play	17-79
Rack Guide Adjustment	17-75		
Fluid Replacement	17-77		
Pump Pressure Check	17-78		
Steering Wheel Rotational Play	17-79		



Special Tools

Ref. No.	Tool Number	Description	Qty	Page Reference
①	07GAF—SD40700	Hub Dis/Assembly Base	1	17-108
②	07JGG—0010100	Belt Tension Gauge	1	17-74
③	07LAG—SM4010A	Piston Seal Ring Guide	1	17-125
④	07LAG—SM4020A	Piston Seal Ring Sizing Tool	1	17-125
⑤	07LAG—SM4030A	Cylinder End Seal Slider	1	17-126
⑥	07MAA—SL0020A	Locknut Wrench, 43 mm	1	17-75, 76, 132
⑦	07MAC—SL00200	Ball Joint Remover, 28 mm	1	17-114, 138
⑧	07NAK—SR3011A	P/S Joint Adapter (Pump)	1	17-78
⑨	07NAK—SR3012A	P/S Joint Adapter (Hose)	1	17-78
⑩	07NAB—SS00100	Rack Holder	1	17-140, 142
⑪	07NAJ—SS0020A	Rear Steering Center Lock Pin	1	17-4, 148, 150, 156, 157
⑫	07406—0010101	Bypass Tube Joint (Included with 07406—0010001)	1	17-80
⑬	07406—0010001	P/S Pressure Gauge	1	17-78
⑬-1	07406—0010300	Pressure Control Valve	1	17-78
⑬-2	07406—0010400	Pressure Gauge	1	17-78
⑭	07725—0030000	Universal Holder	1	17-96
⑮	07746—0010200	Attachment, 37 x 40 mm	1	17-103
⑯	07746—0010300	Attachment, 42 x 47 mm	1	17-120, 123
⑰	07749—0010000	Driver	1	17-123
⑱	07947—6340500	Driver Attachment	1	17-103
⑲	07974—6920500	Hub Assembly Guide Attachment	1	17-145

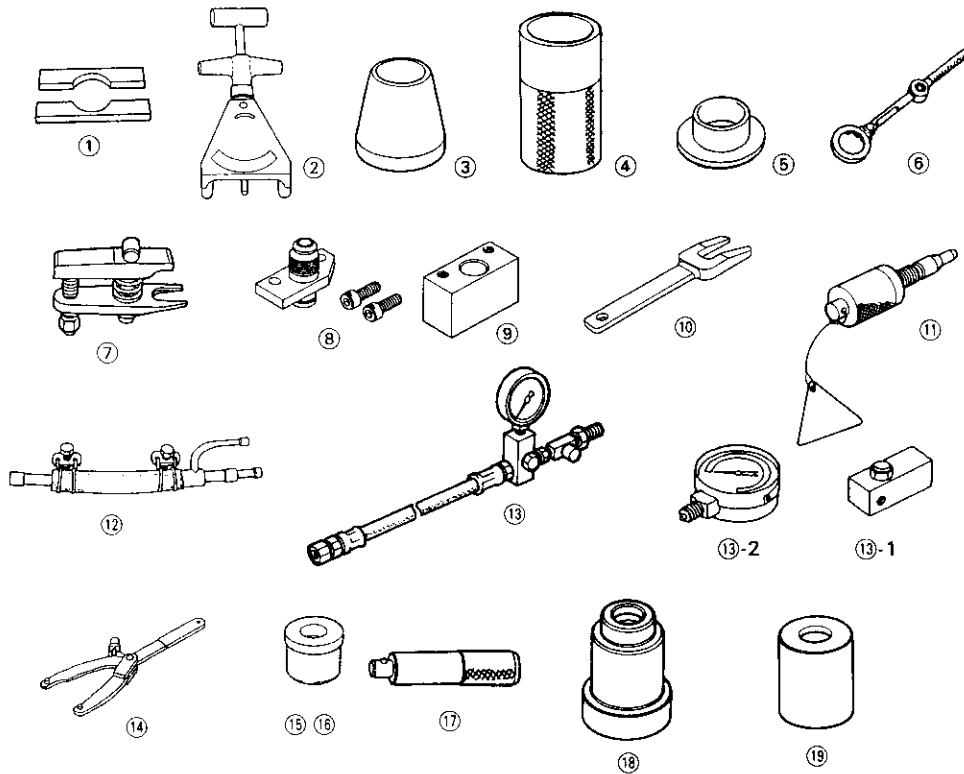



General Information

4WS Service Information

On models equipped with the electronically controlled power assisted 4WS (4-wheel steering system), note the following special precautions before service.

- After performing the following operations, check and adjust the 4WS system to be sure that it is electronically and mechanically in neutral (all 4 wheels in proper alignment).

Operation	Check for mechanical neutral	Check for electronic neutral	Reference page
Rack guide adjustment	—	○	17-76
Steering wheel removal/installation	○	○	17-81, 86
Steering wheel replacement	○	○	17-86
Steering column removal/installation	○	○	17-89, 93
Front steering gearbox removal/installation or disassembly	○	○	17-118, 131
Rear actuator removal/installation	○	○	17-137
Front/rear sub steering angle sensor removal/installation	—	○	17-117, 137
Front main steering angle sensor removal/installation	○	○	17-92
Rear main steering angle sensor removal/installation	—	○	17-137

- The 4WS system must be (1) mechanically and (2) electronically in neutral for proper operation. Perform the following mechanical neutral check on the system and adjust as necessary first, then perform the following electronic neutral check and adjust as necessary. (4WS system adjustment: see page 17-151)

(1) Mechanically neutral:

Be sure that the front and rear wheels align properly with the steering wheel in the straight driving position (i.e. difference in computerized four wheel alignment equipment reading between the right and left wheels is within 0.5 mm/0.02 in).

(2) Electronic neutral:

Be sure that the following sensors are electronically in neutral with the steering wheel in the straight driving position. Electronic neutral position is indicated by blinking or lighting of the 4WS indicator light.

- Front Main Steering Angle Sensor
- Front Sub Steering Angle Sensor
- Rear Main Steering Angle Sensor
- Rear Sub Steering Angle Sensor

4WS INDICATOR LIGHT



(cont'd)

General Information

4WS Service Information (cont'd)

- If the spoke angle of steering wheel is not at the designated angle while driving straight, check whether it was caused simply by an improperly installed steering wheel or by the misalignment of the front and rear wheels. Check the wheels for proper alignment before adjusting the steering wheel spoke angle.
Install the rear steering lock pin in the rear actuator and, with the steering wheel in the straight driving position, check the wheels for proper alignment (i.e. difference in computerized four wheel alignment equipment reading between the right and left wheels is within 0.5 mm/0.02 in).
Check the sensors for electronic neutral to be sure that the rear wheels are in correct steering angle while driving.
- Do not contaminate the front and rear sub steering angle sensors, front and rear main steering angle sensors, and the rear steering actuator motor terminals with mud, oil, and grease.
- The phrase "the steering wheel in the straight driving position" means that the front wheels are in the straight driving position with the steering wheel spokes at a horizontal angle.
- If the power to the 4WS control unit was shut down for the following operations, start the engine and turn the steering wheel fully right and left before checking and adjusting the 4WS system.
 - Battery removal/installation
 - 4WS control unit removal/installation
 - No. 43 fuse CLOCK RADIO removal (in the under-hood fuse/relay box)

CAUTION:

- The rear wheel steering angle is not controlled when the engine is OFF. When the engine is started, the rear wheels are steered to an angle in accordance with the front wheel angle. We recommend that the steering system be serviced with the steering wheel set in the straight driving position.
- Do not start the engine with the lock pin set in the rear actuator. The rear actuator might be damaged when the rear wheels are steered. Be sure to remove the lock pin after service.

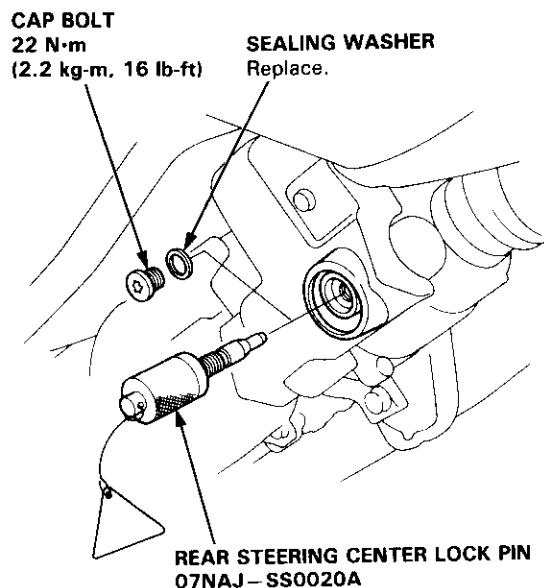



Component Location

Index (2WS/4WS)

NOTE: If an intact driver's airbag assembly has been removed from a scrapped car or has been found defective or damaged during transit, storage or service, it should be deployed (see section 23).

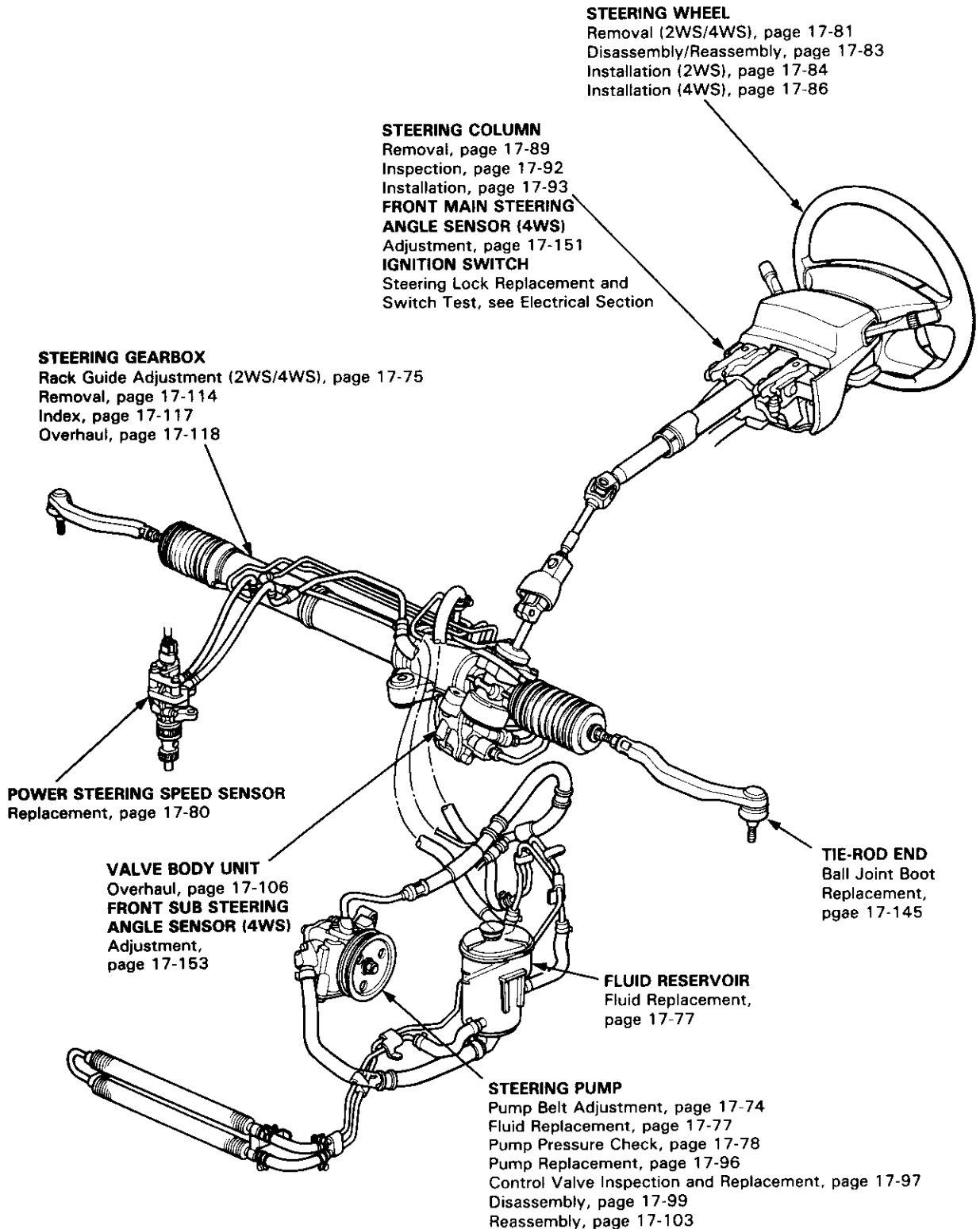

Component Location

Index (4WS)

- **4WS CONTROL UNIT**
Removal/Installation, page 17-145
- **4WS SYSTEM INSPECTION and ADJUSTMENT**
Inspection, page 17-151

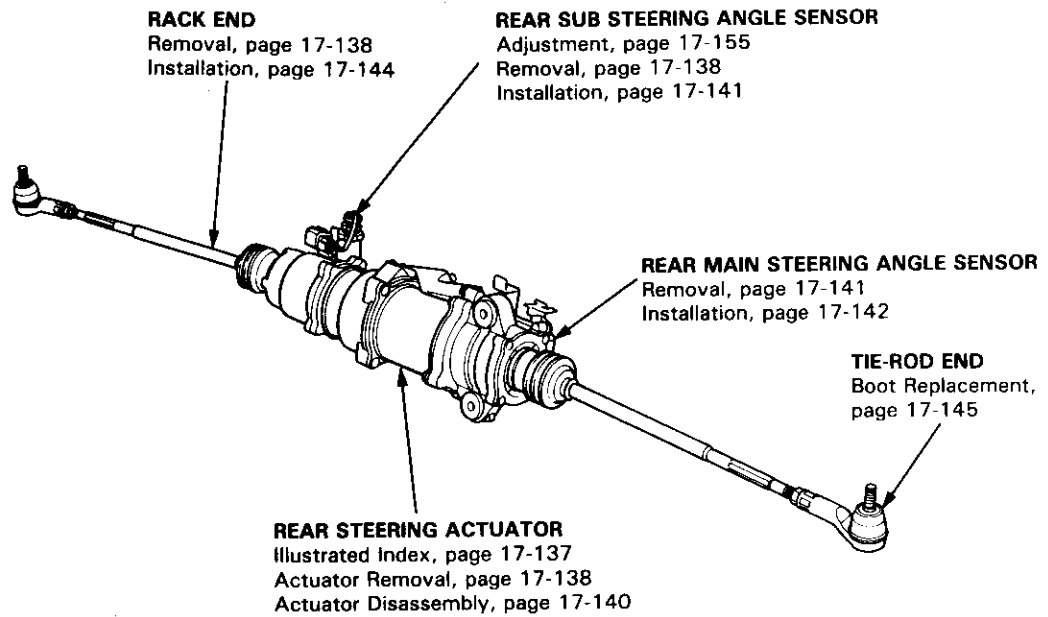



System Description

Fluid Flow Diagram

The reservoir supplies power steering fluid to the pump; the pump pressurizes the fluid and delivers it through a high pressure hose to the valve body unit on the gearbox.

The 4-way valve (in the valve body unit) controls the direction of the turn by shifting fluid to the left or right side of the piston on the rack (in the power cylinder).

The gain control valve in the valve body unit controls the amount of the assist by regulating the stroke of the 4-way valve. The operation of the gain control valve is affected by the fluid pressure, which is regulated by the pressure control valve, sensor orifice and power steering speed sensor.

Constant pressure is generated by the pressure control valve. This pressure is used as a reference pressure for the response to the car speed. By introducing this pressure to the power steering speed sensor through the sensor orifice, the pressure downstream of the orifice is changed according to the speed of car. This pressure is then used to operate the gain control valve. Two orifices are provided around the circumference of the gain control valve. These orifices provide the stepless reduction of the pressure from the pump according to the changes in the car speed. The reduced pressure is then sent to the reaction chambers. Therefore the assist varies by regulating the fluid pressure in the valve body unit according to the speed of car.

Fluid returning from the power cylinder flows back through the 4-way valve and out to the reservoir through the cooler.

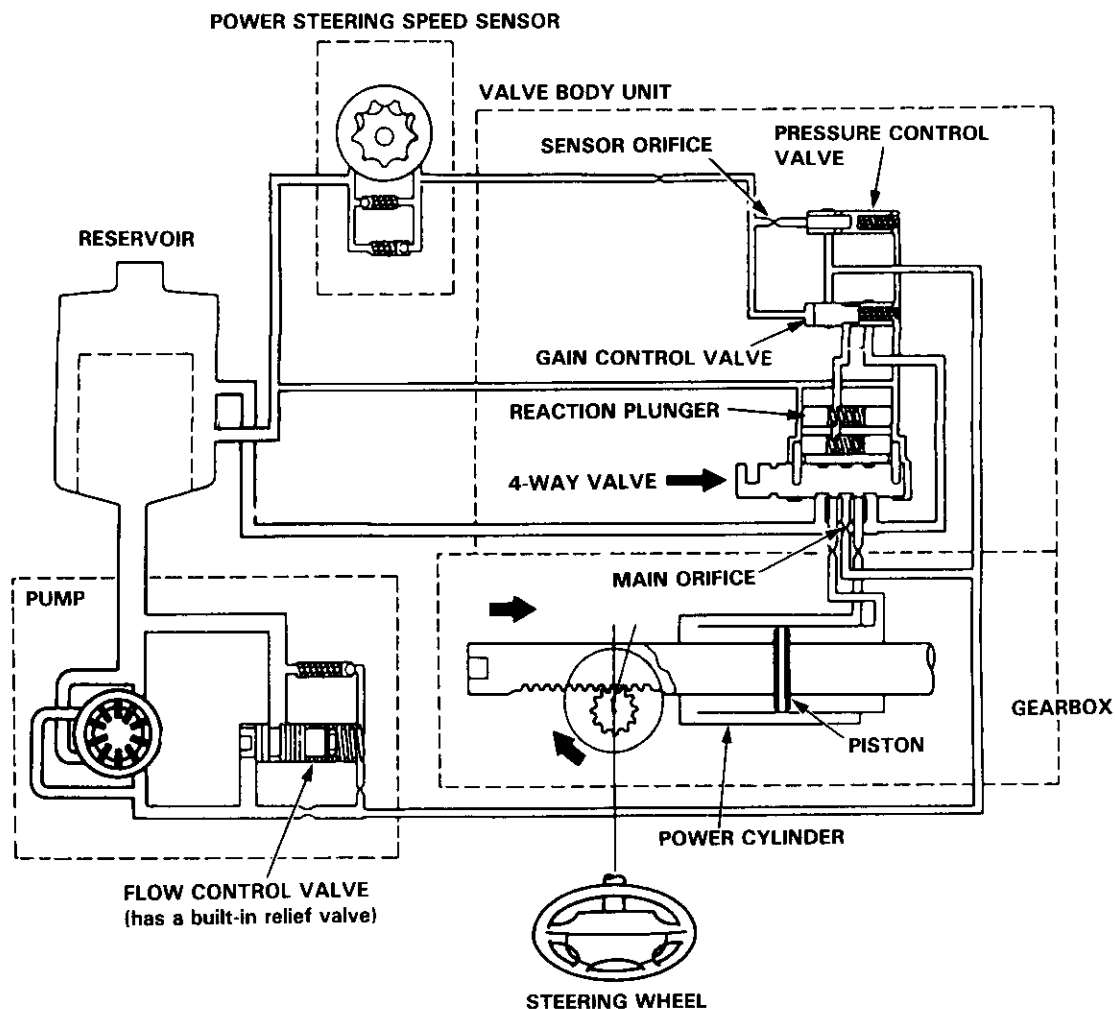

System Description

Steering Pump

Construction

The pump is a vane-type incorporating a flow control valve (with an integrated relief valve) and is driven by a V-belt from the crank pulley. The pump features 10 vanes. Each vane performs two intake/discharge operations for every rotation of the rotor. This means that the hydraulic fluid pressure pulse becomes extremely small during discharge.

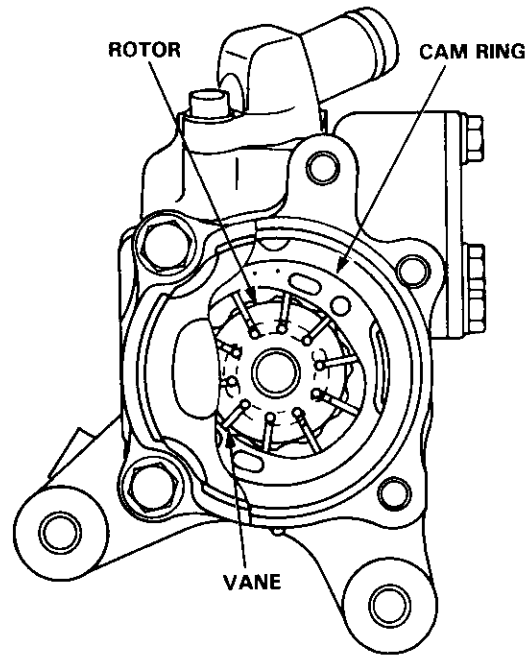
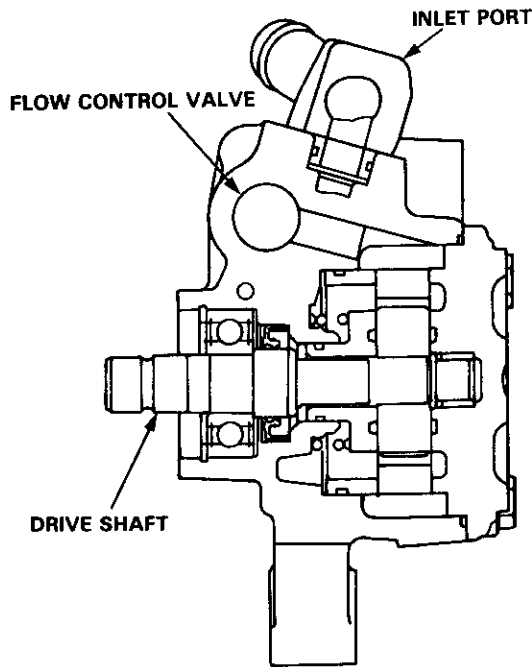

Operation

The belt-driven pulley rotates the rotor through the drive shaft. As the rotor rotates, the hydraulic pressure is applied to the vane chamber of the rotor and the vanes will rotate while being pushed onto the inner circumference of the cam ring. The inner circumference of the cam ring has an extended portion with respect to the center of the shaft, so the rollers move downward in the axial direction as the carrier rotates. As a result of this roller movement, the internal volume of the vane chamber will change, resulting in fluid intake and discharge.

START OF FLUID INTAKE

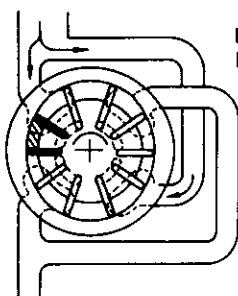

The vanes are pushed onto the inner circumference of the cam ring.

FLUID INTAKE

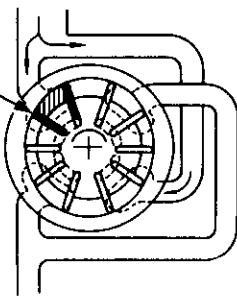

The volume of the vane chamber increases so that fluid is sucked in.

FLUID MOVEMENT

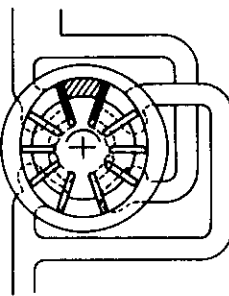

The sucked-in fluid moves toward the discharge port.

FLUID DISCHARGE

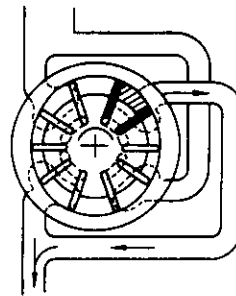

As the vanes return to their original position on the inner side, the volume of the vane chamber decreases so the fluid is discharged from the discharge port.



Flow Control

Fluid from the pump runs through a metering orifice to the valve body unit. This creates a pressure difference between the pump and valve body unit sides of the orifice. When pressure in the pump side is higher than the force of the spring holding the flow control valve closed, it pushes the valve down (open), and excess fluid returns to the pump inlet. The combined effect of the metering orifice and the flow control valve provides a relatively constant flow of fluid to the valve body unit.

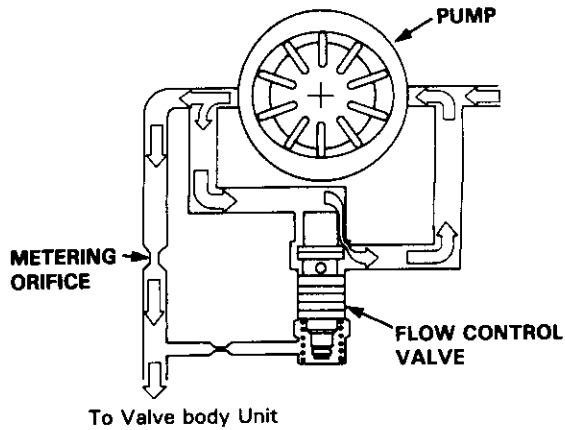

Pressure Relief

As pressure on the valve body unit side builds up, it pushes the relief valve ball (inside the flow control valve) up against its spring, and excess fluid returns to the pump inlet. As the pressure under the flow control valve drops, the relief valve ball is closed by its spring, and the flow control valve is forced down again, allowing excess fluid from the pump side to return to the inlet. This flow control valve-relief valve cylinder keeps pump output pressure between 7000–8000 kPa (70–80 kg/cm², 995–1,138 psi).

RELIEF VALVE OPEN

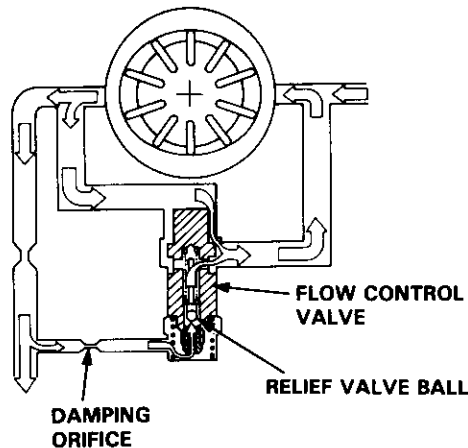

Fluid Reservoir/Filter

A one-piece reservoir and filter is attached to the fender apron on the left side of the engine compartment. The fluid and the filter/reservoir should be replaced if the system is opened for repairs, or if the fluid gets water or dirt in it.

CAUTION: Use only Honda Power steering Fluid-V. The use of other fluid such as A.T.F., or other manufacturer's power steering fluid, will cause damage to the system.

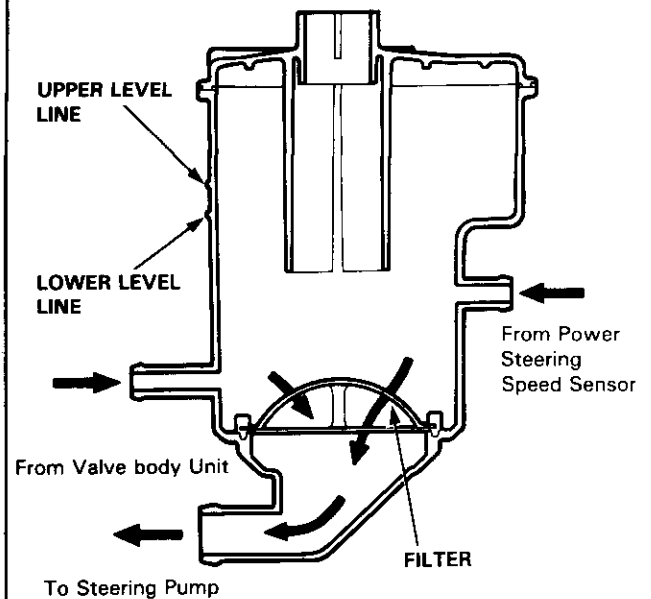

System Description

4-Way Valve

Mounted on the lower side of the gearbox is a 4-way valve that is moved horizontally by a pin on the pinion holder to shift fluid pressure to the right or left side of the power cylinder when the steering wheel is turned. It has thrust pins at both ends, and two inter-connected reaction chambers, one on each side. Each reaction chamber contains a pair of spring-loaded plungers that rise against right and left thrust pins. The valve body fluid passages are controlled by the 4-way valve. Fluid pressure in the reaction chambers is reduced by the gain control valve in order to change the amount of the assist in accordance with the change in the car's speed.

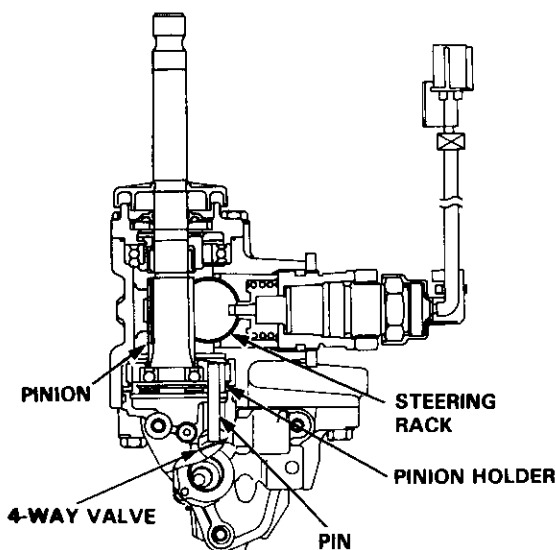
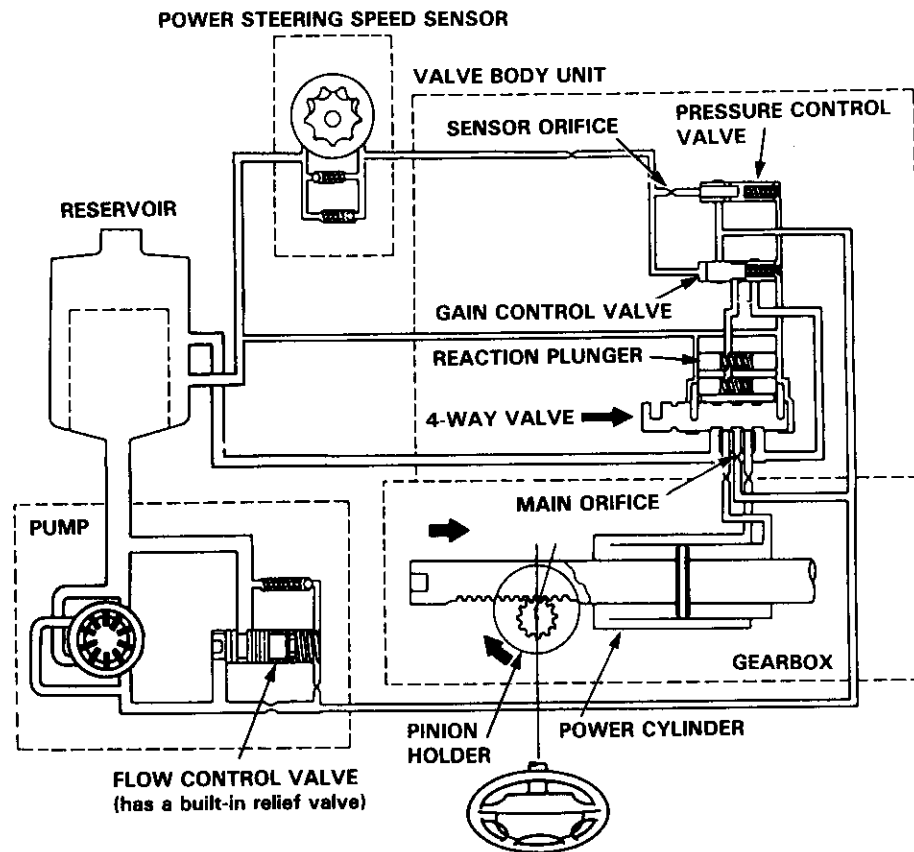



In the power steering unit, the method used to direct a single source of fluid pressure in either of two directions (for left or right turns) involves the pinion gear transferring a "message" of direction to the fluid in the 4-way valve. The pinion is mounted slightly off-center in a pair of bearings, which are in turn mounted in a pinion holder cylinder that rotates, centered in its own outer bearings. At the bottom of the Pinion Holder is a pin, which fits in a slot in the 4-way valve.

As the pinion is turned (to turn left or right), because it is off-center, it also moves slightly along the rack. This movement is transferred to the holder. The pin in the holder then moves the 4-way valve, to direct fluid pressure to either side of the rack in the power cylinder.

The back edges of the pinion holder (facing away from the rack) hit the stops cast into both sides of the gear housing to avoid pushing the 4-way valve too far in either direction. The front edge of the pinion holder cuts off assist at full lock as described on the next page.

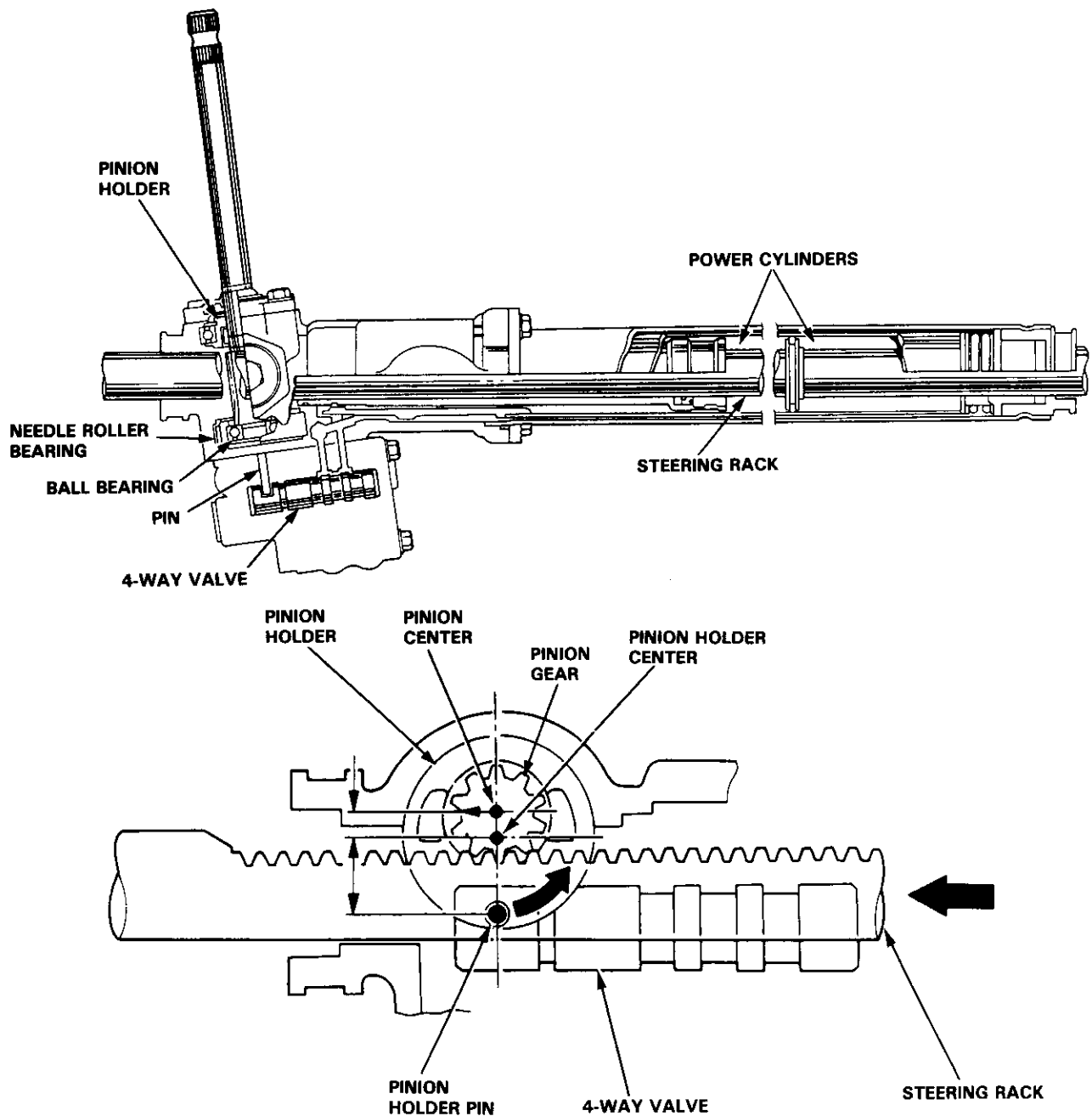

System Description

Full-lock Unloader System

The 4-way valve shifts the direction of fluid flow when the steering wheel is turned right or left.

However, when the wheel is turned to the right or left lock at parking speed, the edge of the pinion holder rides up on the end of the rack, moving the pin in the opposite direction which pulls the 4-way valve back to neutral.

This keeps pump pressure from building up (which could cause idle speed to drop), and improves steering feel by increasing resistance at left and right lock.

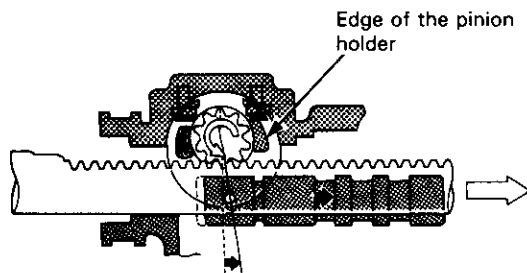

Control in "assist" position

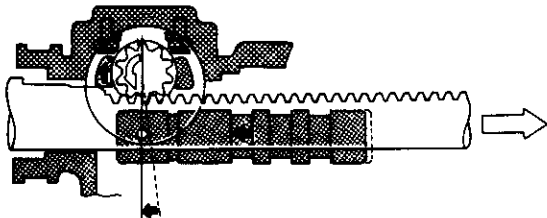

4-way valve moves back to "neutral" position

Power Steering Speed Sensor

The power steering speed sensor is a trochoid-rotor, hydraulic pump combined with a relief valve and a one-way valve. It is driven by the speedometer gear shaft which in turn is driven by a helical gear on the differential.

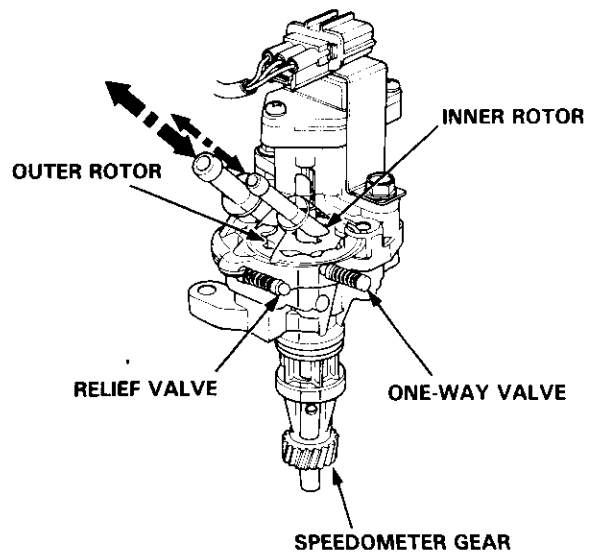

The power steering speed sensor turns only when the car is moving, controlling the gain control valve.

The constant pressure is generated by the pressure control valve.

This pressure is used as a reference pressure for the response to the car's speed. By introducing this pressure to the power steering speed sensor through the sensor orifice, the pressure downstream of the orifice is changed according to the speed of the car.

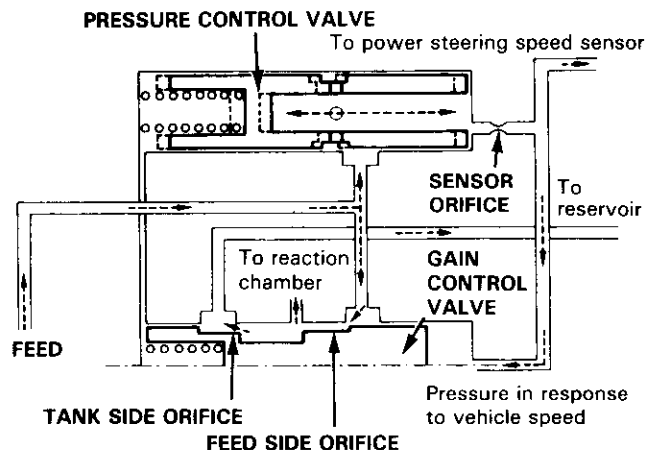



With the engine running at idle in a parked car, fluid flow through the sensor rotors is blocked because the rotors are not turning. Therefore the gain control valve moves to the left. On the gain control valve, the orifice resistance is high on pump side, while it is low on the reservoir side, with the result that pressure in the reaction chamber is lowered and steering assist is high.

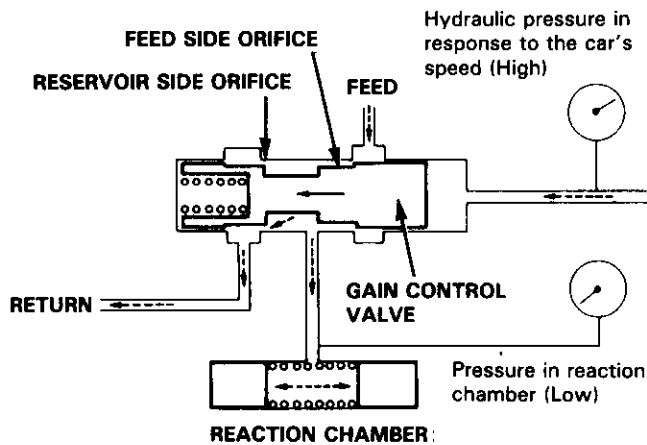

As the car is driven, the rotors start turning and the fluid returns to the reservoir, reducing the fluid pressure at the gain control valve. Therefore, the gain control valve begins to move to the right. The orifice resistance on the pump and reservoir sides is appropriately balanced, with the result that the reaction chamber is in the medium range and the steering resistance is moderate.

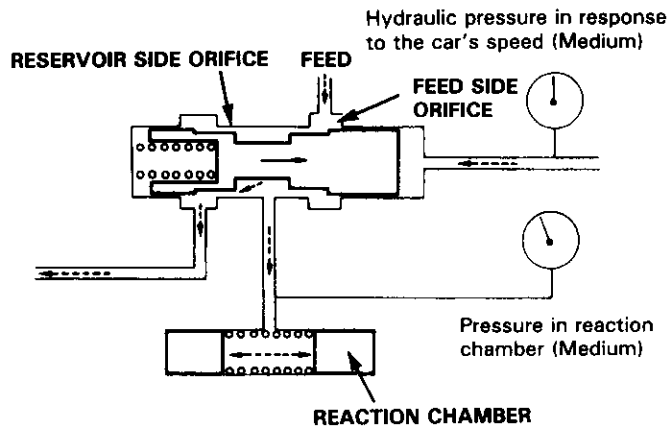

When the car is moving at high speed, the sensor reduces the pressure further and the gain control valve moves further to the right. The orifice pressure on the pump side is low and the pressure on the reservoir side is high, the fluid pressure in the reaction chamber is also high giving the steering wheel less assist.

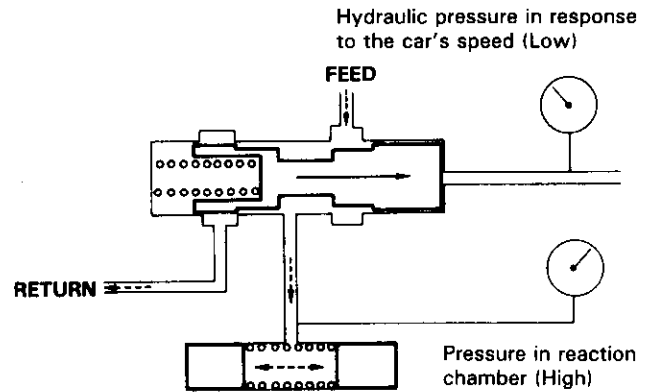

(cont'd)

System Description

Power Steering Speed Sensor (cont'd)

One-way Valve (In Power Steering Speed Sensor)

When the car is moving at high speed, negative pressure develops at the sensor inlet because the power steering speed sensor is pumping faster than the fluid can be supplied. To compensate for this, the outlet and inlet ports are connected internally by a passage containing a one-way valve that lets output fluid recirculate to the inlet port to equalize pressure.

Driving at High Speed:

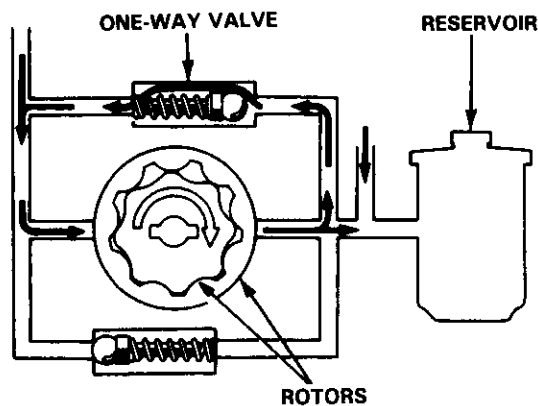
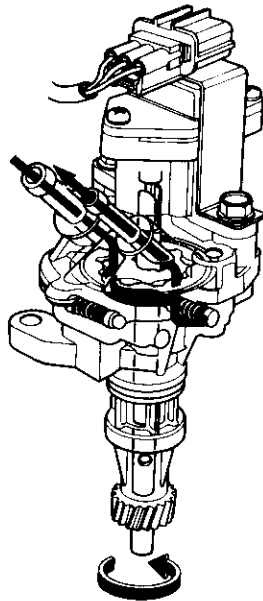

Relief Valve (In Power Steering Speed Sensor)

When the car is moving in reverse, the power steering speed sensor also turns backward and pumps fluid in the opposite direction. To avoid building up pressure in the reaction chambers that would increase steering effort while driving in reverse, the inlet and outlet-ports are connected by a second internal passage containing a relief valve that allows the fluid to recirculate.

Driving in Reverse:

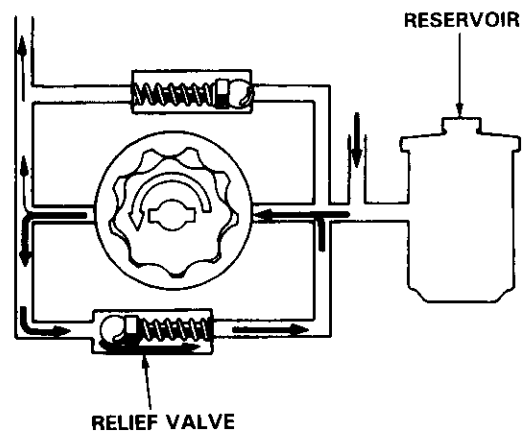
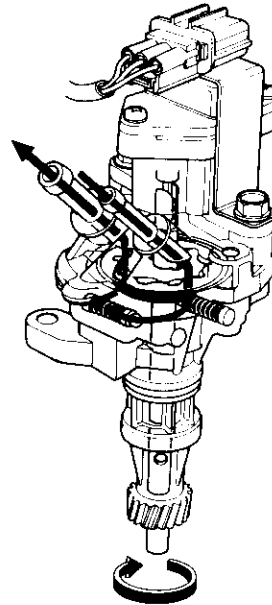



Electronically Controlled Power Assisted 4WS

Outline

The electronically controlled power assisted 4WS (4-wheel steering system) consists of the hydraulic power steering system that steers the front wheels, the rear actuator that steers the rear wheels, the 4WS control unit, and the sensors that detect the car's speed and other steering conditions. The front steering gearbox and the rear actuator are connected by a wire harness. The rear steering angle is controlled electrically, allowing the rear wheels to be set at any designated steering angle.

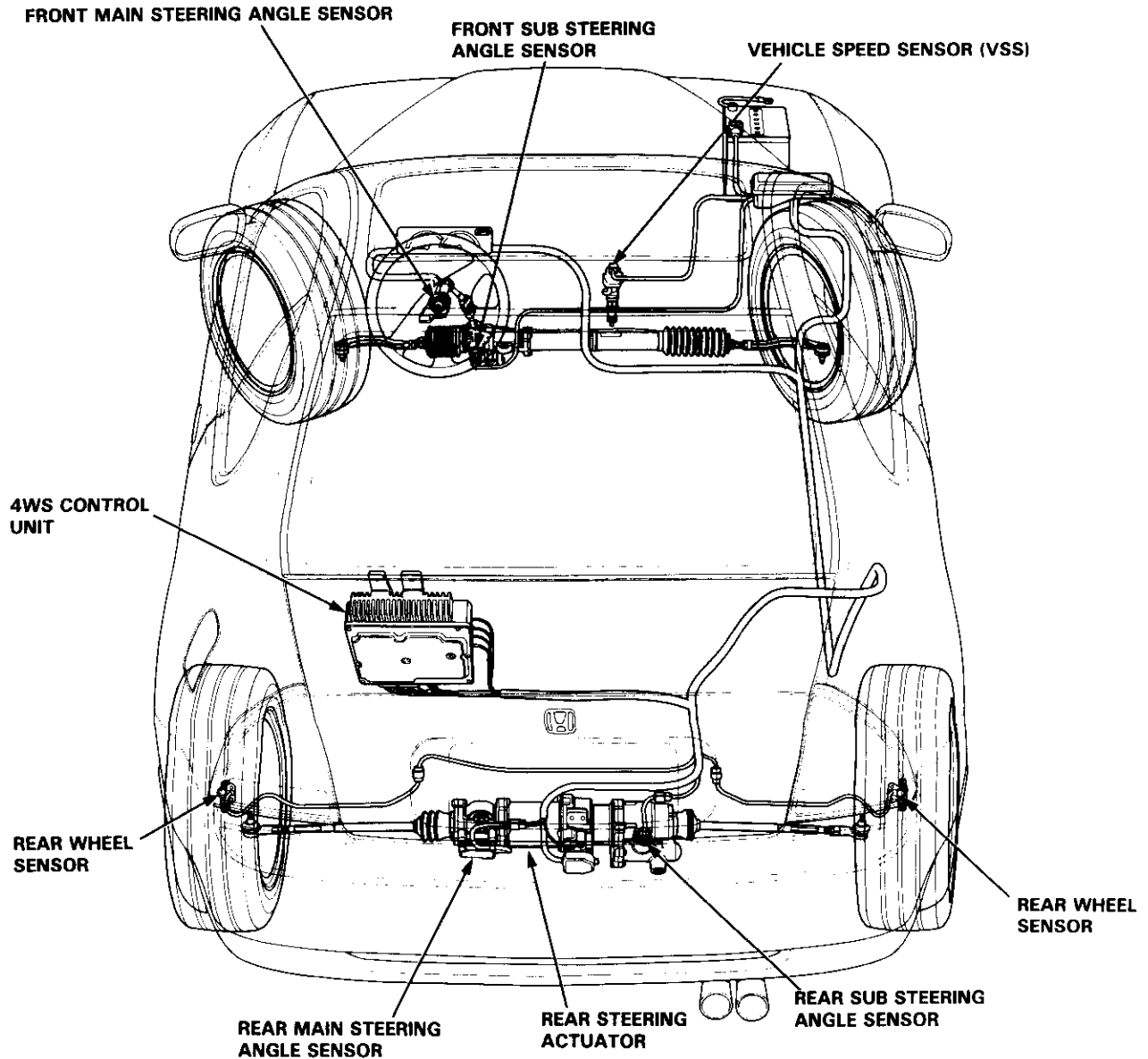

(cont'd)

System Description

Electronically Controlled Power Assisted 4WS (cont'd)

System Operation

The 4WS control unit receives input from the Vehicle Speed Sensor (VSS), front main steering angle sensor, and the front sub steering angle sensor. The 4WS control unit calculates the vehicle speed, steering turning angle, steering speed and steering direction to determine the best angle to steer the rear wheels.

(System operation flow)

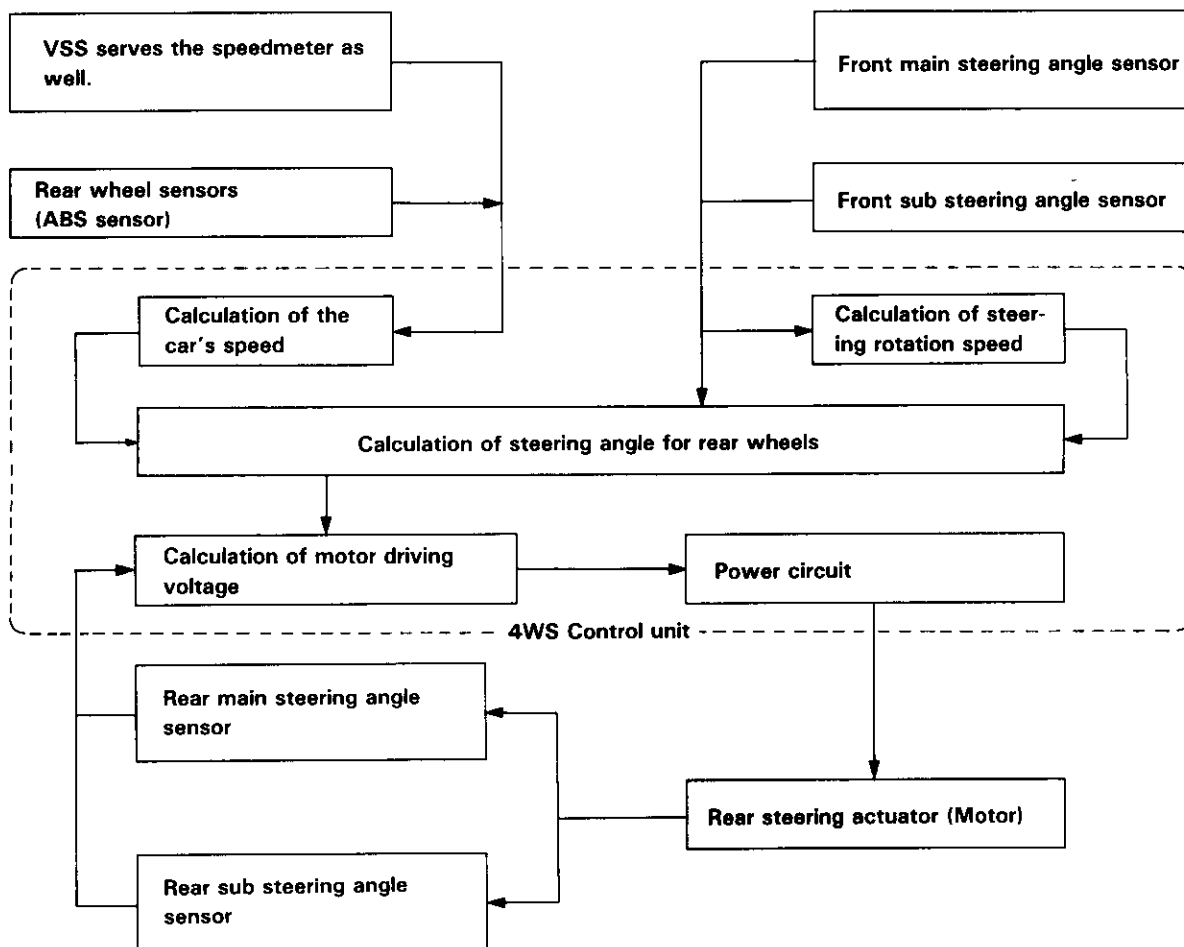



The rear wheels are turned by a motor built into the rear steering actuator. The motor is activated by the power circuit in the 4WS control unit. The actual steering angle of the rear wheels is detected by the rear main steering angle sensor, and the rear sub steering angle sensor. The 4WS control unit adjusts the angle according to the difference between the sensed steering angle of the rear wheels and the targeted steering angle of the rear wheels.

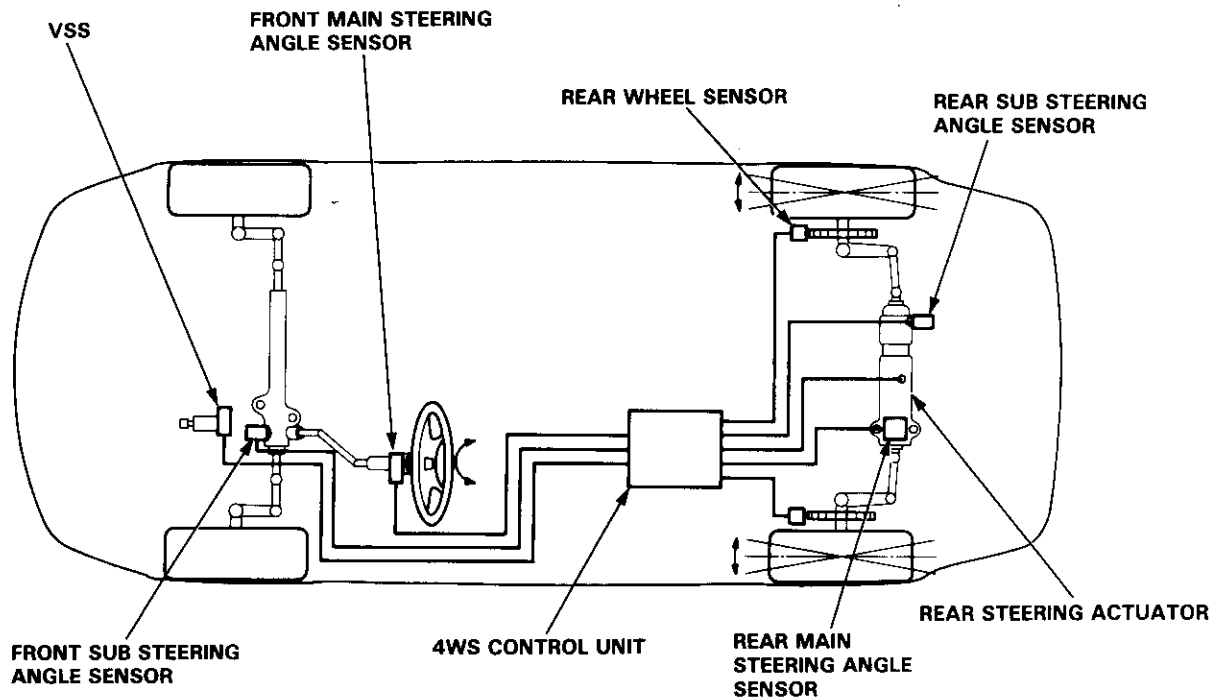

(cont'd)

System Description

Electronically Controlled Power Assisted 4WS (cont'd)

System Operation

Features of rear wheel steering:

The electronically controlled power assisted 4WS sets the rear wheels at the best steering angle for the car's speed, steering rotation speed, steering wheel angle, etc.

- Car speed

When the car is traveling at low speed, the 4WS system turns the rear wheels in the reverse direction of the front wheels in proportion to the rotation angle of the steering wheel. When the car is traveling a higher speed, the system increases the steering angle of the rear wheels in the same direction as the front wheels.

Changing the steering angle performance of the rear wheels in relation to the car's speed gives the car improved handling characteristics.

- Steering speed 18 mph (30 km/h) or above

The rear wheel steering angle varies with how rapidly the steering wheel is rotated. See graph.

(Steering angle/speed performance curve)

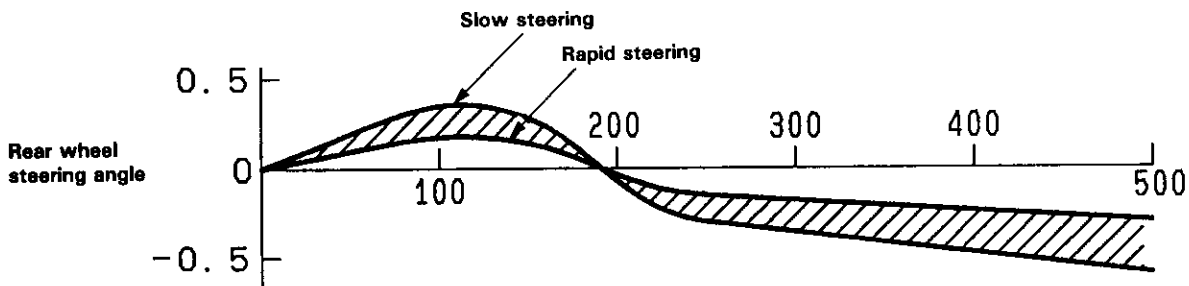



Component Function & Operation

Rear actuator:

The rear actuator is mounted at the rear of the car to steer the rear wheels. The motor, built into the actuator, is made up of a stator with a permanent magnet, a rotor, and brushes that pass electricity to the commutators. The motor is mounted on the same axis as the steering shaft screw, making the rear actuator compact and light in weight. The rear actuator also contains the rear main steering angle sensor and the rear sub steering angle sensor.

The 4WS control unit drives the electric motor with DC current. It switches the current polarity to change the motor's direction. Two strong return springs, one at each end of the actuator, provide a centering action. They return the rear wheels to the straight-ahead position whenever current is cut to the motor.

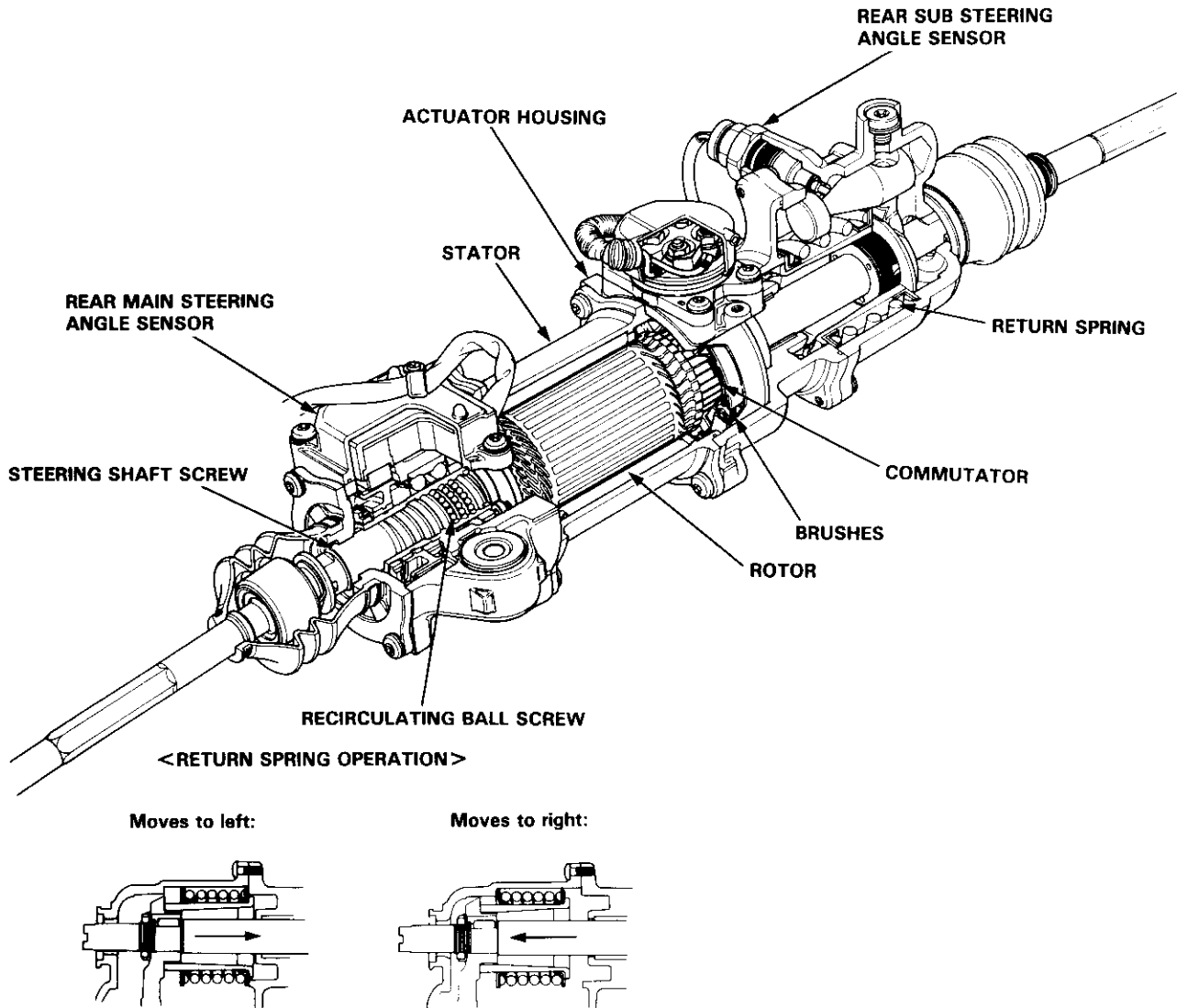

The return spring compresses when the steering shaft screw moves to right or left. When the motor is OFF, the steering shaft screw is held in the straight ahead (neutral) position by the force of the return spring.

(cont'd)

Maintenance

Transmission Oil

NOTE: Check the oil with the engine OFF, and the car on level ground.

1. Remove the oil filler plug, then check the level and condition of the oil.

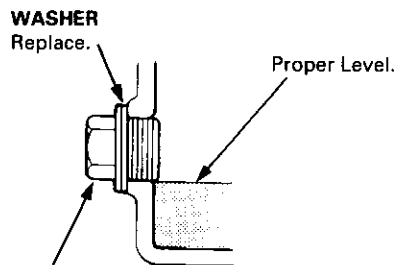

OIL FILLER PLUG
45 N-m (4.5 kg-m, 33 lb-ft)

2. The oil level must be up to the fill hole. If it is below the hole, add oil until it runs out, then reinstall the oil filler plug.
3. If the transmission oil is dirty, remove the drain plug and drain the oil.
4. Reinstall the drain plug with a new washer, and refill the transmission oil to the proper level.

NOTE: The drain plug washer should be replaced at every oil change.

5. Reinstall the oil filler plug with a new washer.

Oil Capacity

1.9 l (2.0 US qt, 1.7 Imp qt) at oil change.

2.0 l (2.1 US qt, 1.8 Imp qt) at overhaul.

Use only SAE 10 W — 30 or 10 W — 40, SF or SG grade.

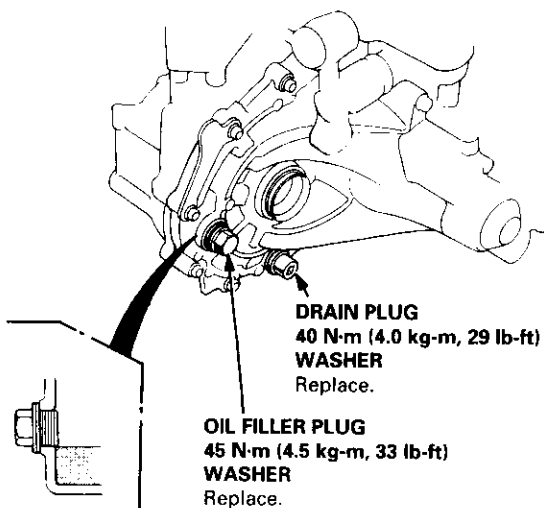

Back-up Light Switch



Replacement

NOTE: Check the switch see section 23.

1. Disconnect the back-up light switch wire connectors.
2. Remove the back-up light switch.

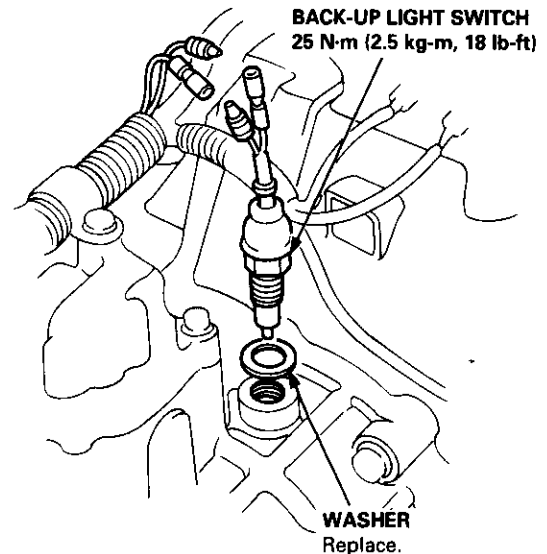

3. Install the new washer and back-up light switch.

System Description

Electronically Controlled Power Assisted 4WS (cont'd)

Component Function & Operation

Front main steering angle sensor:

The front main steering angle sensor is mounted in the steering column. It senses the direction and angle of steering wheel rotation and converts it to electrical signals that are sent to the 4WS control unit.

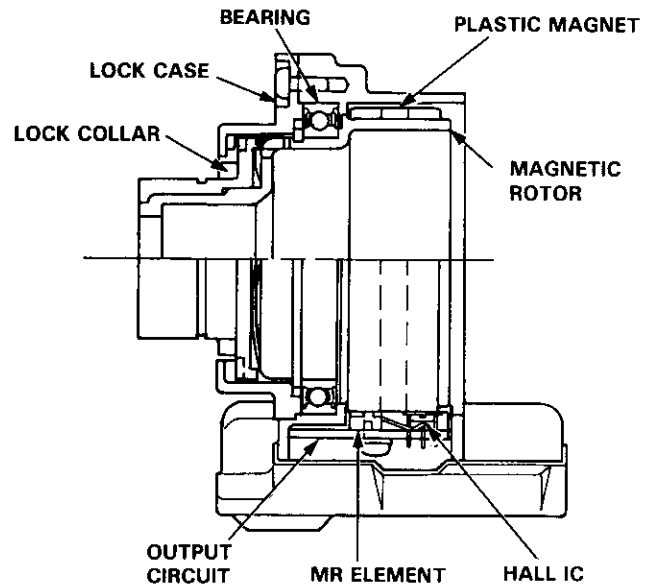

Rear main steering angle sensor:

The rear main steering angle sensor is mounted on the rear actuator. It senses the direction and angle of the rear wheels and sends signals to the 4WS control unit. The 4WS control unit uses this information as feedback to determine if the actual rear wheel position matches the desired position.

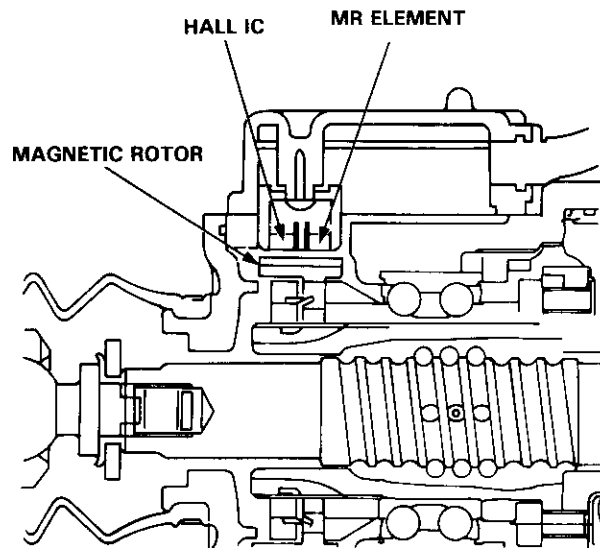



Front sub steering angle sensor:

The front sub steering angle sensor is mounted on the front steering gearbox. Its purpose is to detect the position of the front wheels and convert this information to an electrical signal for the 4WS control unit.

The front sub steering angle sensor uses a spring-loaded plunger that rides in a sloped groove in the rack. As the rack turns the front wheels, the plunger rides up the slope and is pushed into the differential transformer assembly. The plunger's position is used to determine how far the rack is turned.

FRONT SUB STEERING ANGLE SENSOR

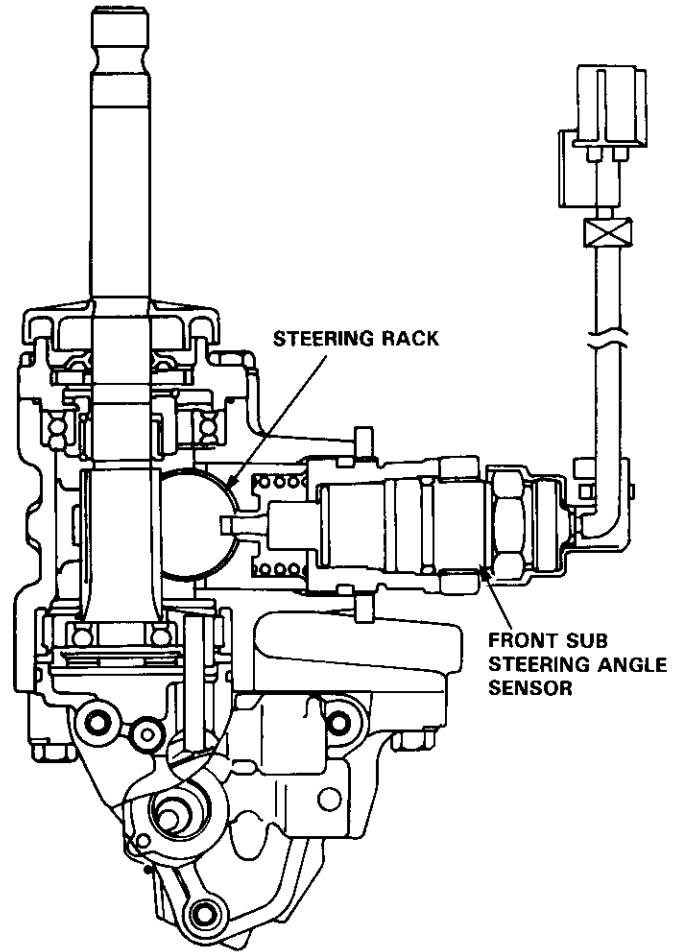
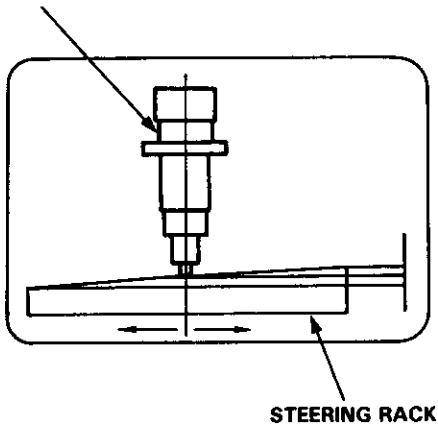

Rear sub steering angle sensor:

The rear sub steering angle sensor is mounted on the rear actuator spring cover. It detects the position of the rear wheels as a feedback signal for the 4WS control unit. It operates in exactly the same way as the front sub steering angle sensor.

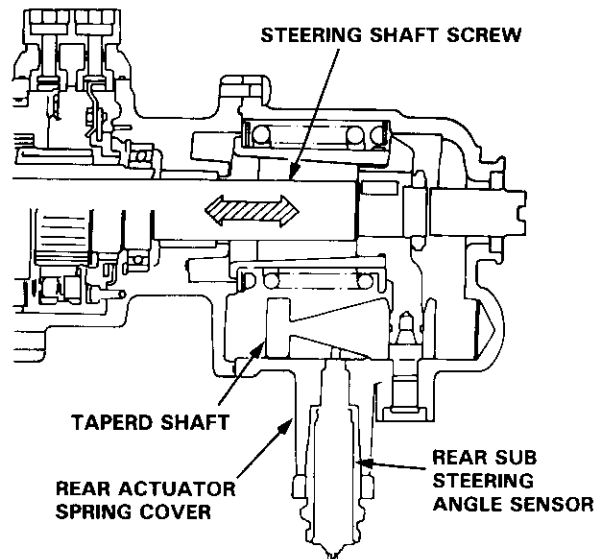

(cont'd)

System Description

Electronically Controlled Power Assisted 4WS (cont'd)

Component Function & Operation (cont'd)

- Average moving current control

The 4WS control unit monitors the average moving current of the motor to protect the system. When the average moving current exceeds a given value, the 4WS control unit lowers the current to change steering angle of the rear wheels gradually (approximately 6 degrees/30 seconds). When the average moving current to the motor is below the given value, the rear wheels return to the designated steering angle slowly (approximately 6 degrees/2 minutes).

- Over-voltage control

An increase in battery voltage (due to a voltage regulator failure, for example) could cause excessive actuation of the motor and erratic control of the rear wheels. To prevent this, the 4WS control unit monitors the voltage. If it exceeds a given value, the 4WS control unit slowly returns the rear wheels to the straight ahead position by reducing voltage to the motor and turns the 4WS indicator light ON.



Fail-safe Function:

When the 4WS control unit senses a failure in the system, it switches to fail-safe mode. In this mode, it powers the fail-safe and damper relays. The fail-safe relay cuts power to the rear steering motor, while the damper relay slows the motor's return to neutral. As a result, the rear wheels return slowly to the straight ahead position and then remain there. The car then drives like conventional 2WS.

When the 4WS control unit switches to fail-safe mode, it stores a Diagnostic Trouble Code (DTC) and turns on the 4WS indicator light to notify the driver of a problem. This code can be read by connecting the service check connector terminals with a jumper wire under the dash. The code is read as blinks of the 4WS indicator light.

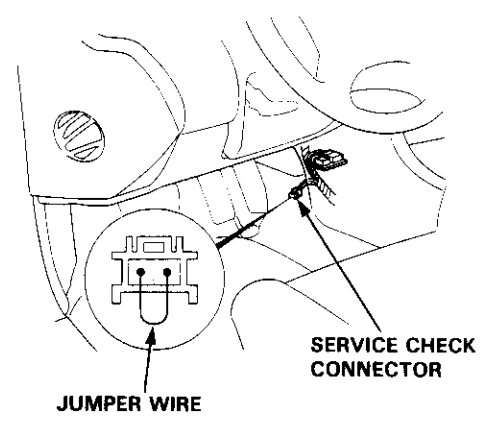
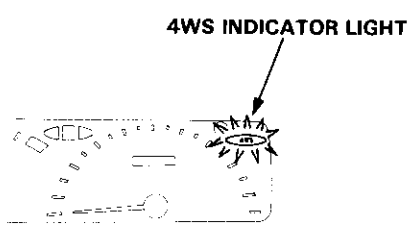

Damper Control:

When the system goes into fail-safe mode, it cuts power to the motor by powering the fail-safe relay. Without some type of damping, the returns springs would turn the rear wheels to the straight-ahead position too rapidly, adversely affecting the car's handling.

To counteract this, the 4WS control unit also powers the damper relay. The armature of the now deactivated motor is spun by the movement of the steering shaft. This causes the motor to act as a generator. The voltage generated by this action is applied back to the motor through the damper relay. This causes the motor to resist the force of the return springs, allowing the rear wheels to go back to the straight ahead position slowly.

(cont'd)

System Description

Electronically Controlled Power Assisted 4WS (cont'd)

Component Function & Operation (cont'd)

- Electronic neutral position

For the 4WS system to work correctly, it must be in electronic alignment as well as mechanical alignment. In other words, the system's front and rear sensors must signal that the wheels are pointed straight ahead when the wheels are mechanically pointed straight ahead. The technician can test for "electronic straight ahead" by connecting the service check connector terminals with a jumper wire and turning the front and rear wheels.



Troubleshooting (Power Steering System)

General Troubleshooting

Check the following before you begin:

- Has the suspension been modified in a way that would affect steering?
- Are tire sizes and air pressure correct?
- Is the steering wheel original equipment or equivalent?
- Is the power steering pump belt properly adjusted?
- Is steering fluid reservoir filled to proper level?
- Is the engine idle speed correct and steady?

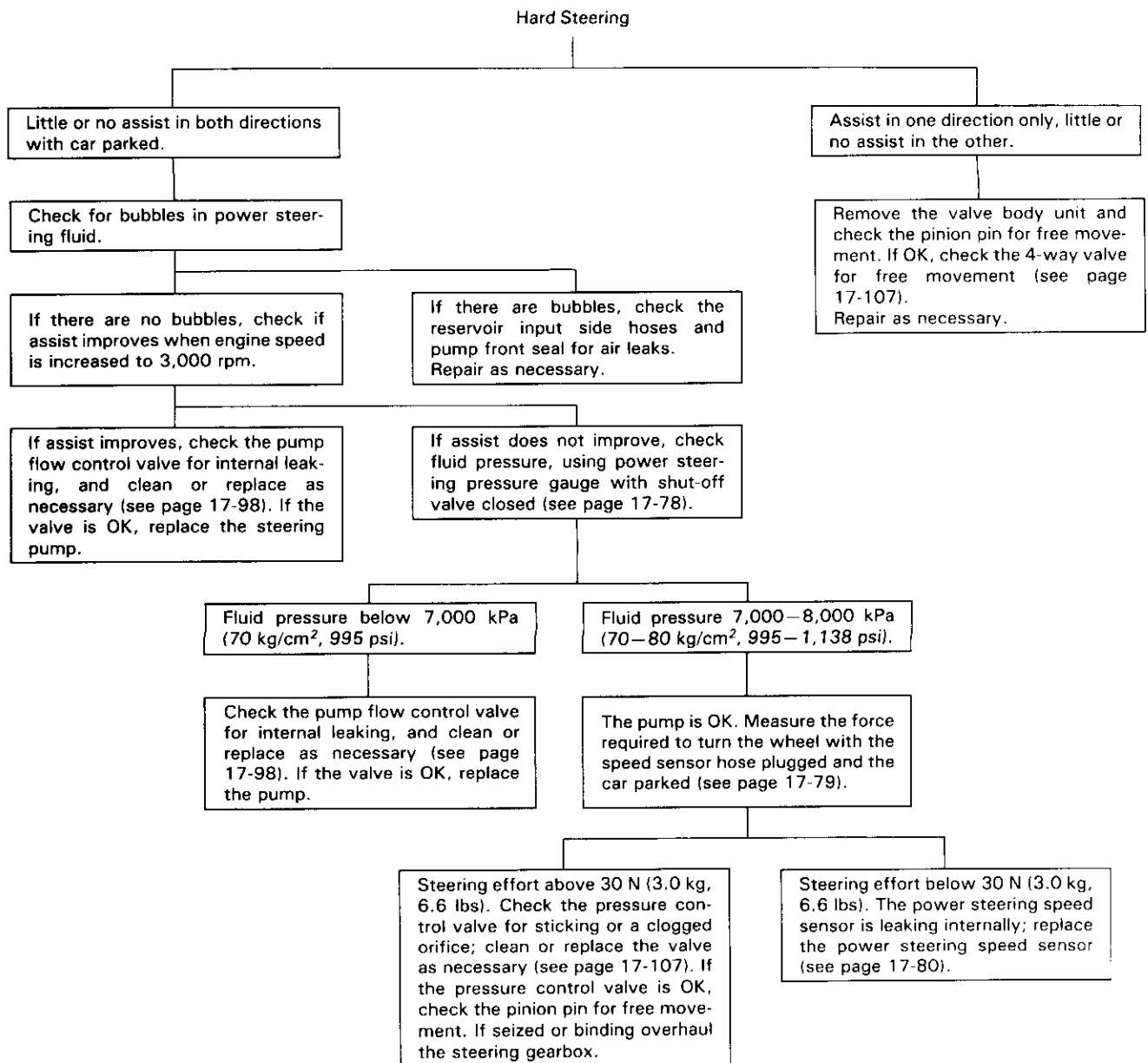

(cont'd)

Troubleshooting (Power Steering System)

General Troubleshooting (cont'd)

Uneven or rough steering.

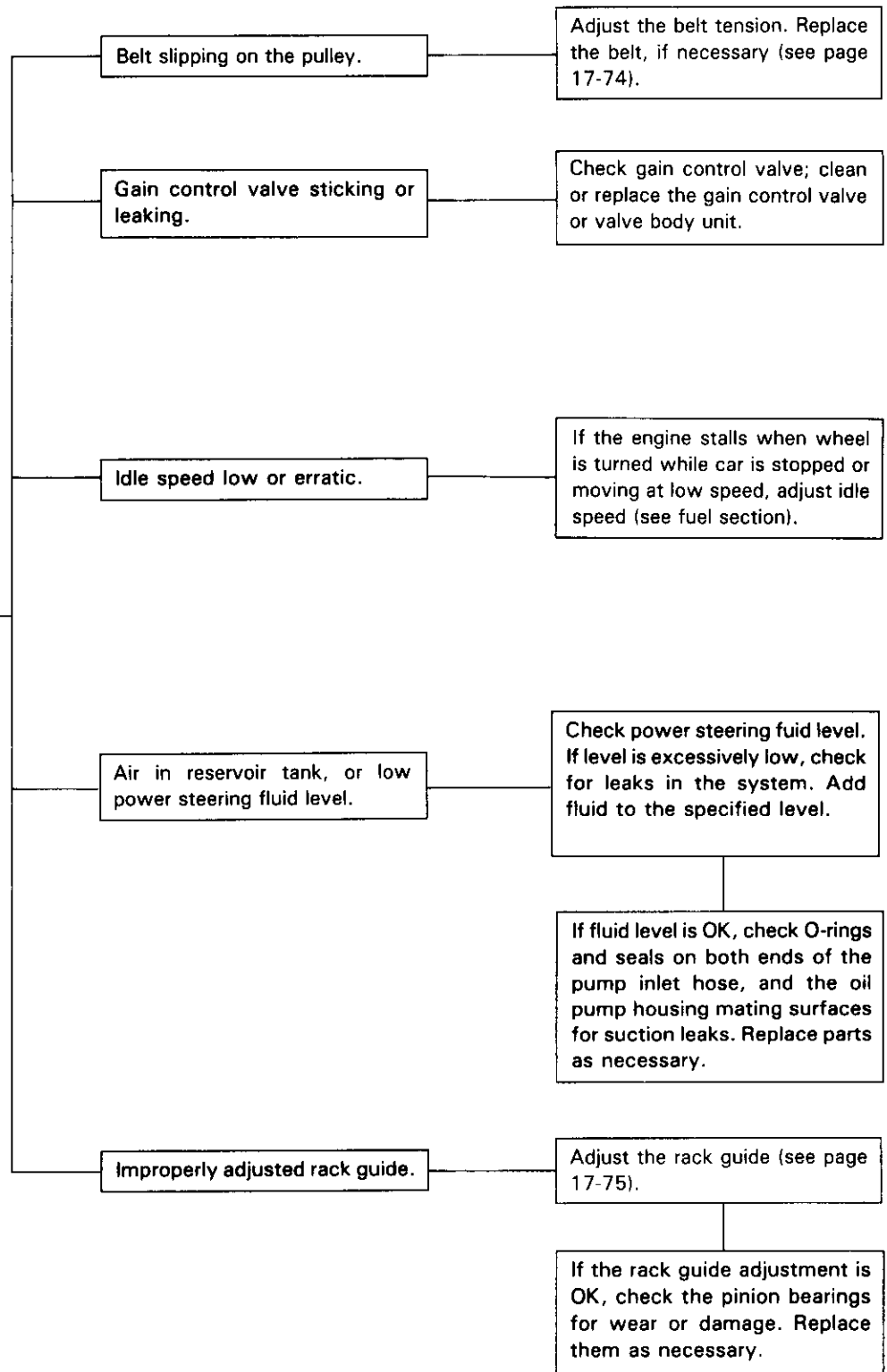



Shock or vibration when wheel is turned to full lock.

Pump belt slipping on pulley (pump stops momentarily).

Adjust the belt tension (see page 17-74) or replace belt.

Set the power steering pressure gauge. Close the shut-off valve fully and measure the pump pressure (see page 17-78).

The pump pressure should be 7,000–8,000 kPa (70–80 kg/cm², 995–1,138 psi) with needle fluctuation of ± 500 kPa (± 5 kg/cm², ± 70 psi) or less. If the needle fluctuation exceeds ± 500 kPa (± 5 kg/cm², ± 70 psi) check the flow control valve, if the flow control valve is OK, replace the pump.

Assist (excessively light steering) at high speed:

Measure force required to turn wheel with bypass tube joint installed, and car parked on dry paved surface (see page 17-80).

If below, check gain control/pressure control valves and valve body unit and replace parts as necessary.

Pump belt slipping.

Adjust the belt tension (see page 17-74) or replace belt.

Steering kicks back during wide turns.

Sticking gain control valve or valve body unit.

Replace the gain control valve or valve body unit.

Rack guide adjusted too loose.

Adjust the rack guide (see page 17-75).

Wheel will not return smoothly.

Tire pressure too low.

Inflate to correct pressure.

Improper front wheel alignment.

Readjust the front wheel alignment or replace parts as necessary.

Improperly adjusted rack guide.

Adjust the rack guide (see page 17-75).

Troubleshooting (Power Steering System)

Noise and Vibration

NOTE: Pump noise in first 2–3 minutes after starting in cold weather (-20°C , -4°F or colder) is normal.

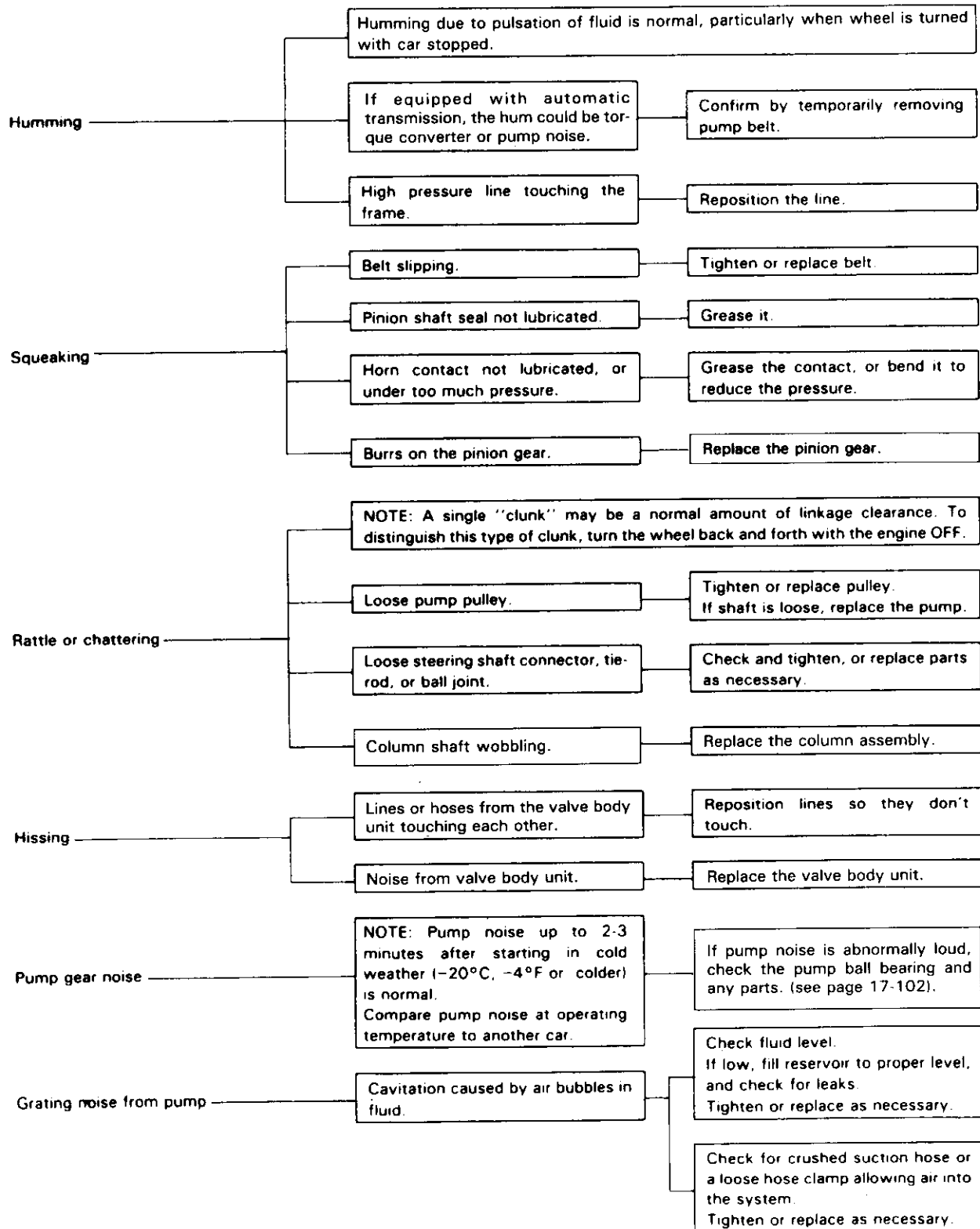



Fluid Leaks

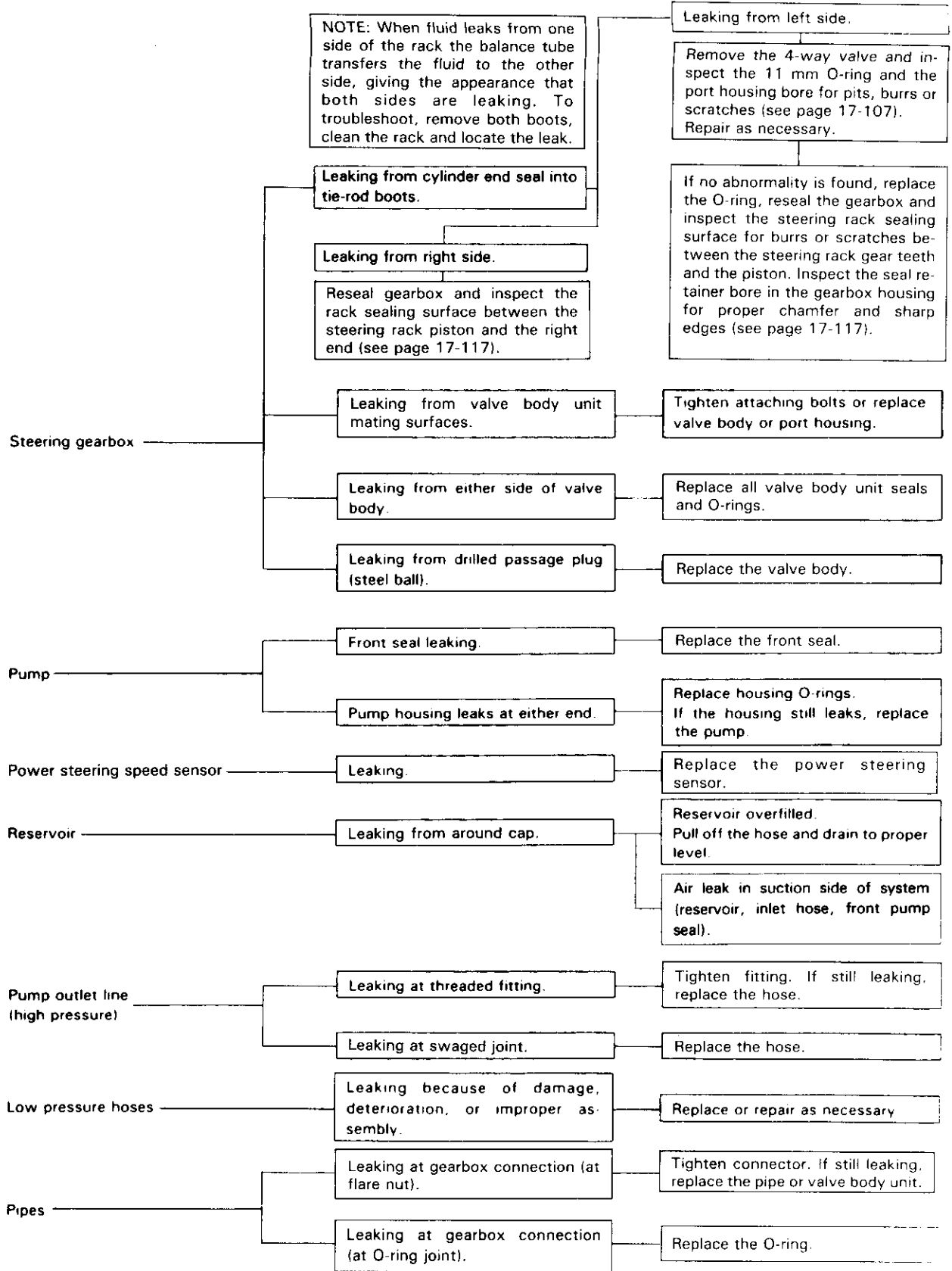

Troubleshooting (4WS)

Component Location

NOTE:

The radio may have a coded theft protection circuit.

Be sure to get the customer's code number before

- Disconnecting the battery.
- Removing the No. 43 CLOCK, RADIO (10 A) fuse.
- Removing the radio.

After service, reconnect power to the radio and turn it on.

When the word "CODE" is displayed, enter the customer's 5-digit code to restore radio operation.

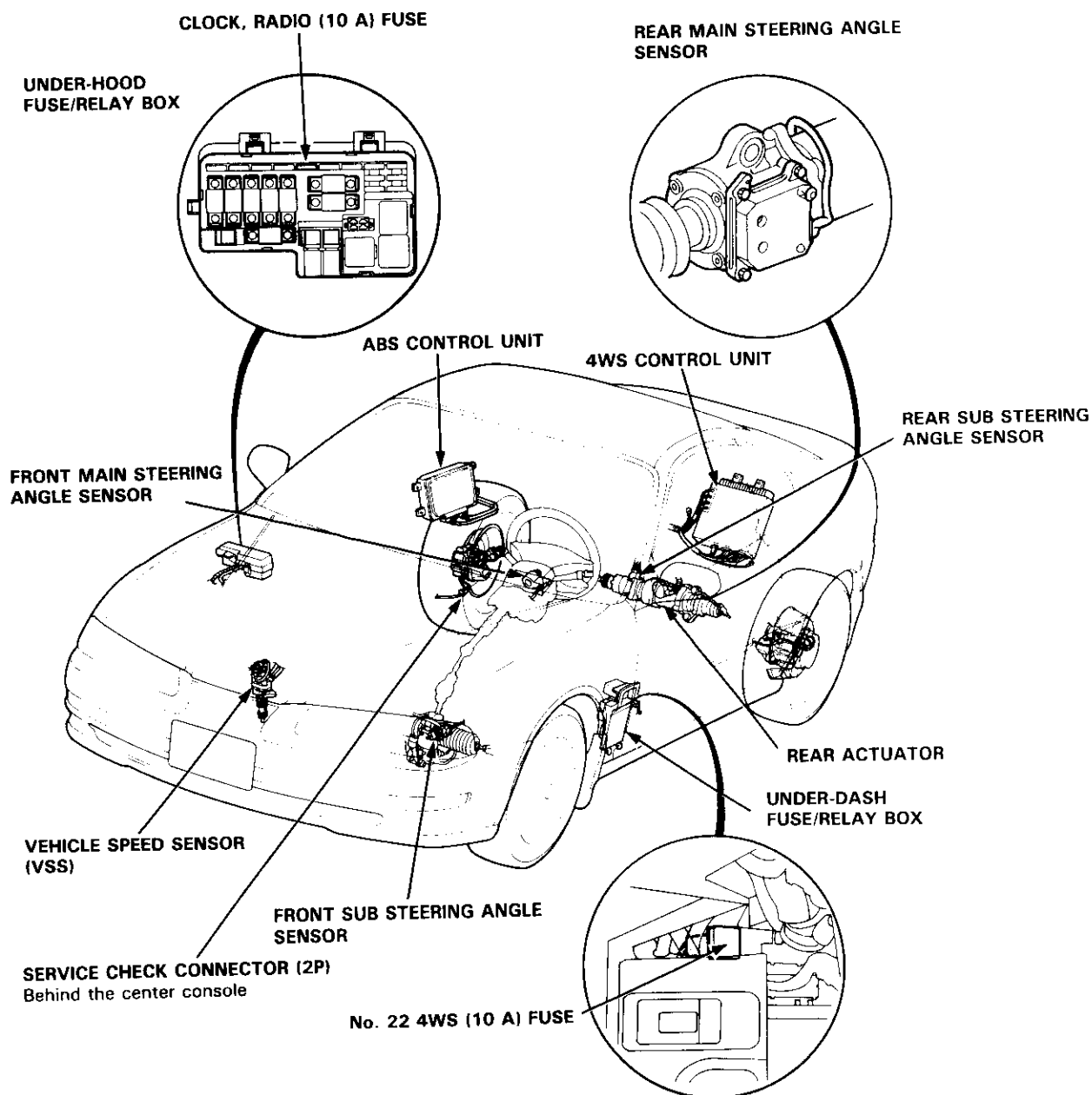



Connector Locations

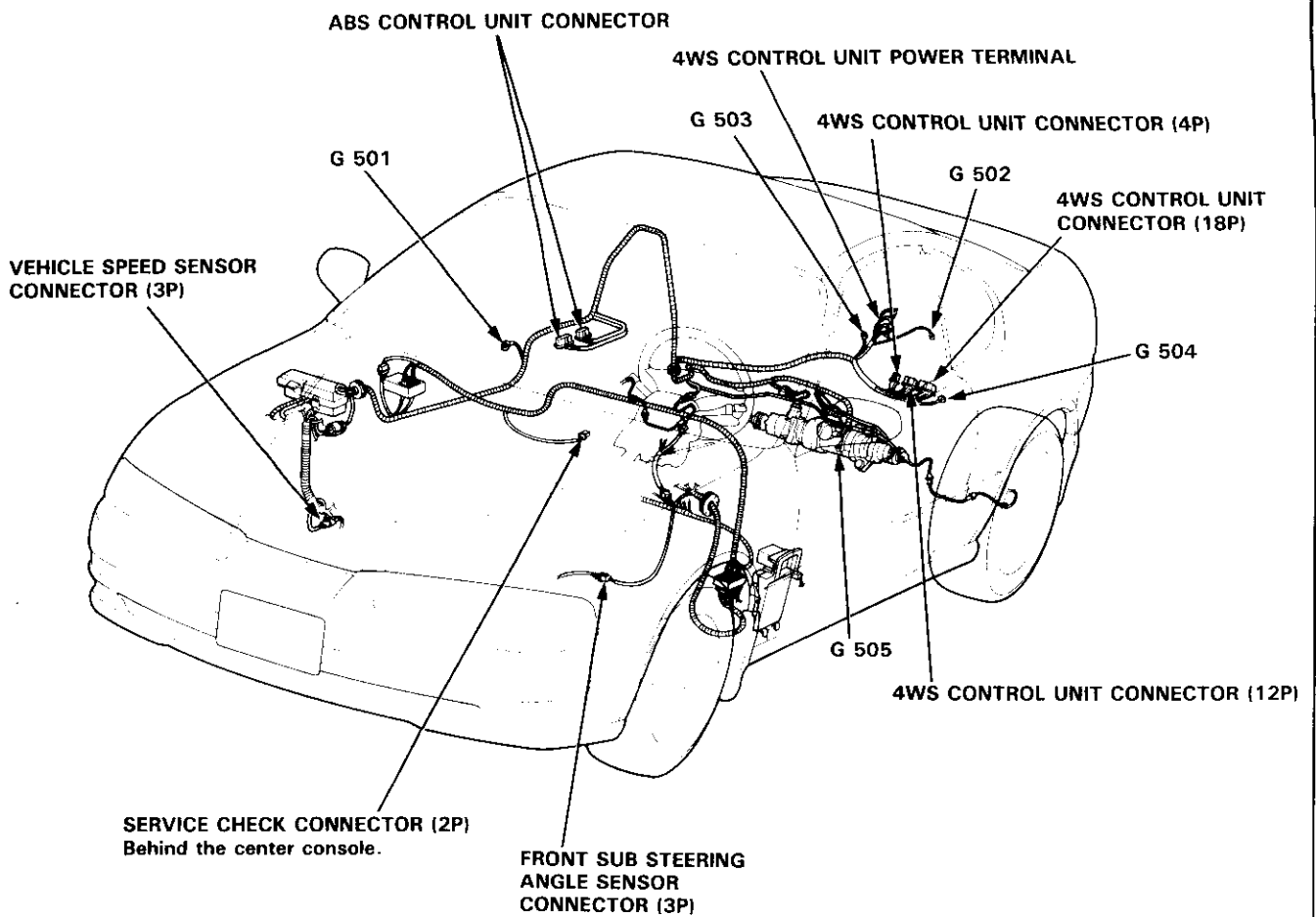

Troubleshooting (4WS)

Circuit Diagram

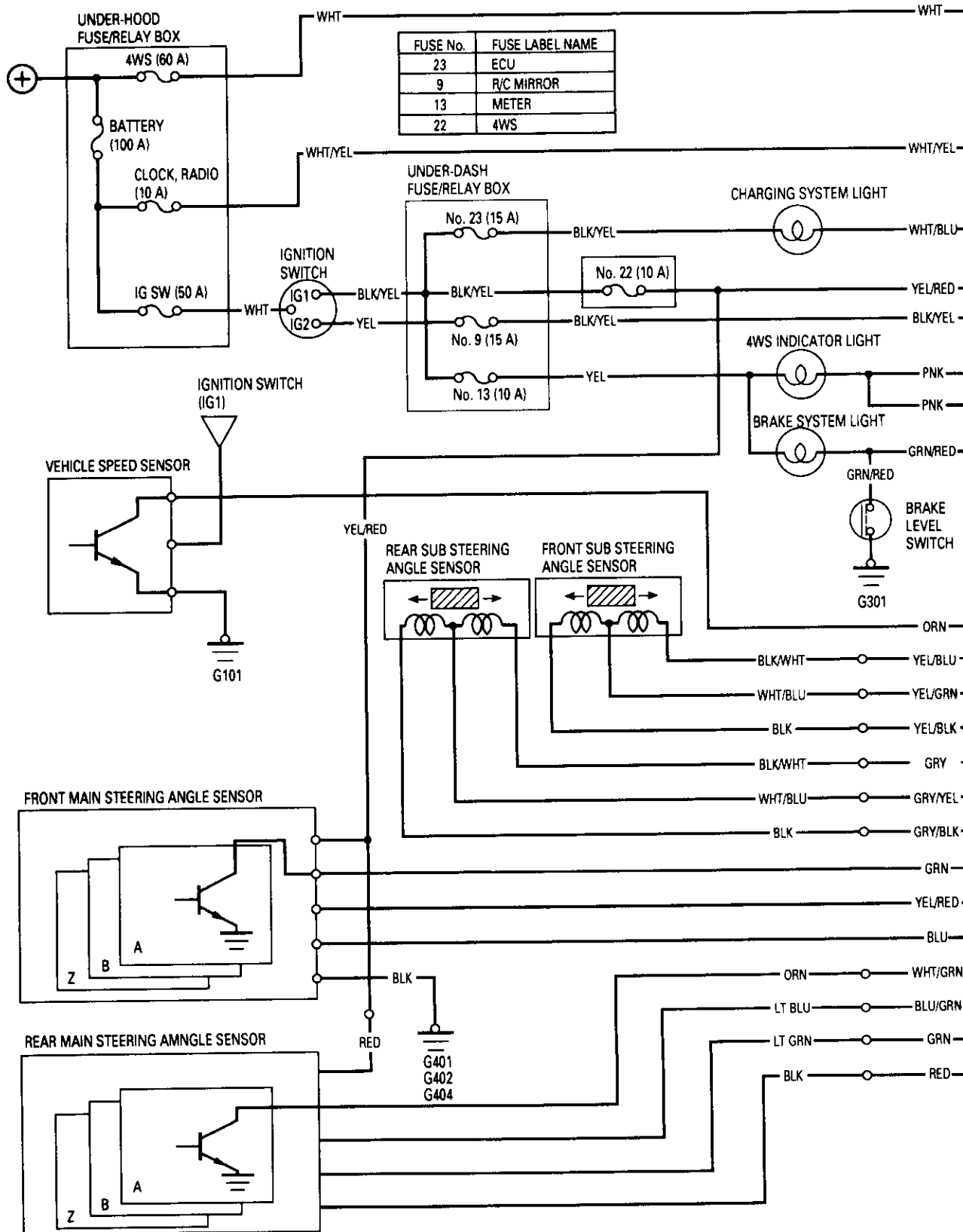



WHT

4WS CONTROL UNIT

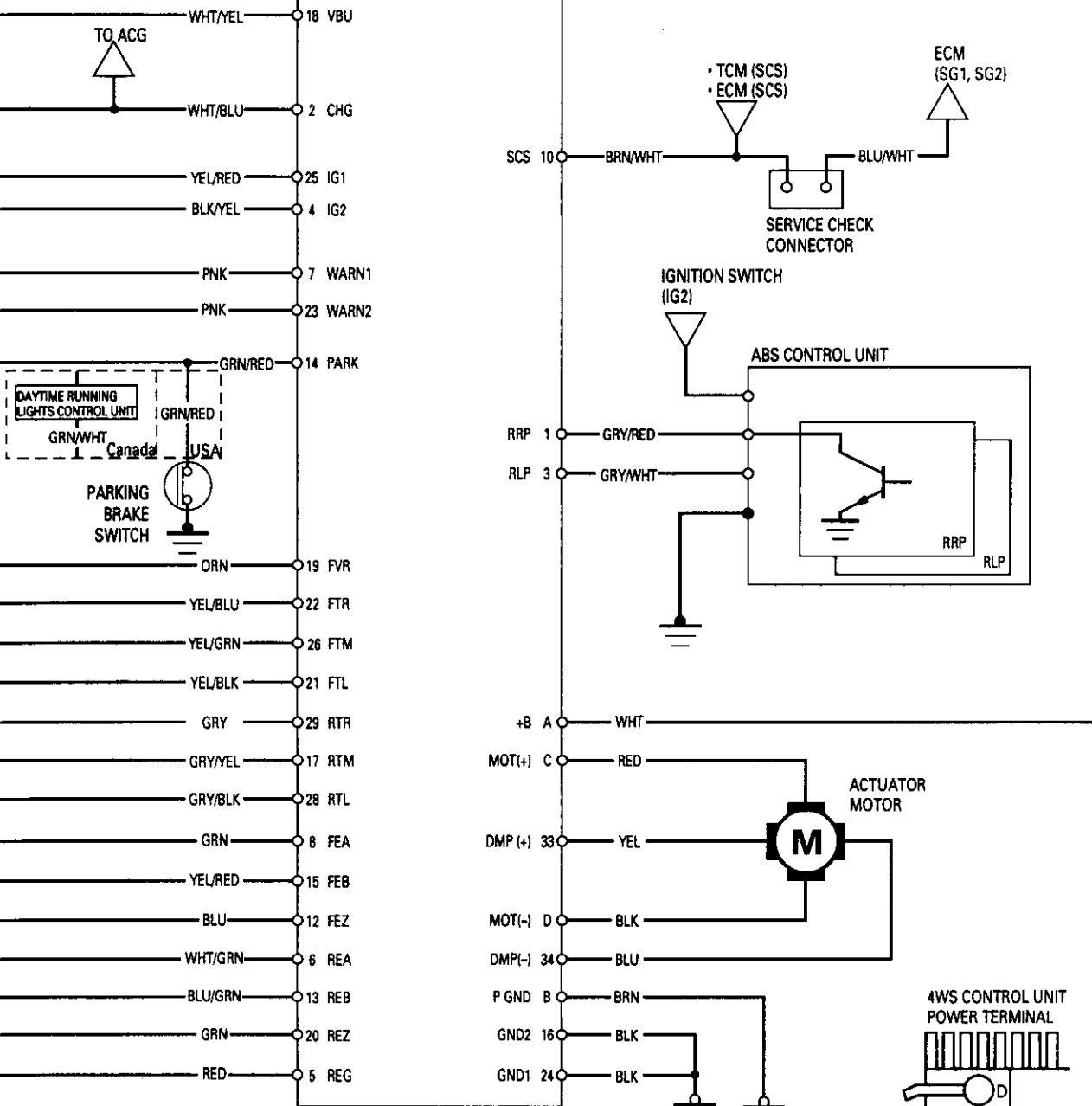

18P CONNECTOR

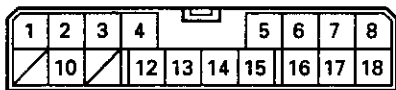

12P CONNECTOR

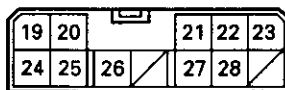

4P CONNECTOR

4WS CONTROL UNIT CONNECTOR

Troubleshooting (4WS)

4WS CONTROL UNIT Terminal Arrangement

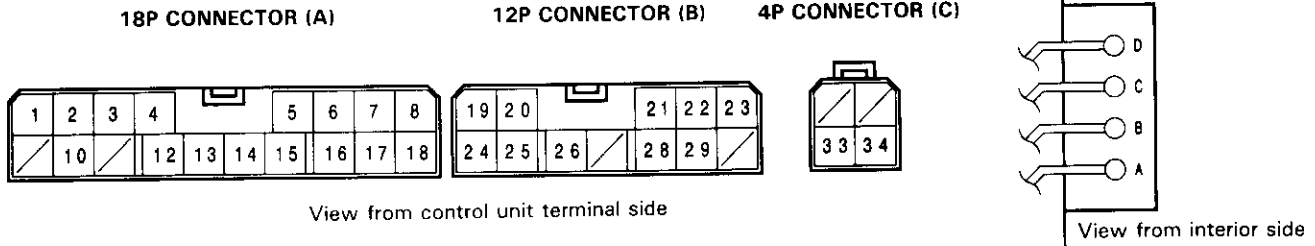

con- connector	con- connector No.	Wire color	Terminal name	Check		
				Measurement condition	Normal voltage	Measuremt terminals
A	1	GRY/RED	Rear right pulse	While the wheel is being rotated slowly	5 V↔0 V	1-24
	2	WHT/BLU	Charge	Engine ON	Battery voltage.	2-24
				Engine OFF	0 V	
	3	GRY/WHT	Rear left pulse	While the wheel is being rotated slowly	5 V↔0 V	3-24
	4	BLK/YEL	Ignition 2	IG SW ON	Battery voltage	4-24
				IG SW OFF, ACC, START	0 V	
	5	RED	Rear main steering angle sensor ground	IG SW ON	0 V	5-ground
	6	WHT/GRN	Rear main steering angle sensor A phase	While actuator motor is running slowly	5 V↔0 V	6-24
	7	PNK	Warning 1	Light ON	0 V	7-24
				Light OFF	Battery voltage	
	8	GRN	Front main steering angle sensor A phase	While steering wheel is being rotated slowly	5 V↔0 V	8-24
	9	---	---	---	---	---
	10	BRN/WHT	Service check signal	Short	0 V	10-24
				Open	5 V (AT : 11 V)	
	11	---	---	---	---	---
	12	BLU	Front main steering angle sensor Z phase	While steering wheel is being rotated slowly	5 V↔0 V	12-24
	13	BLU/GRN	Rear main steering angle sensor B phase	While actuator motor is running slowly	5 V↔0 V	13-24
	14	GRN/RED	Parking brake	ON	0 V	14-24
OFF				Battery voltage		
15	YEL/RED	Front main steering angle sensor B phase	While steering wheel is being rotated slowly	5 V↔0 V	15-24	
16	BLK	Ground 2	IG SW ON	0 V	16-ground	
17	GRY/YEL	Rear sub steering angle sensor center	Analog tester DC range	approx. 2.5 V	17-24	
18	WHT/YEL	Back up power source	At all times	Battery voltage	18-24	

IG SW: Ignition switch, ACC: accessory (1 position)

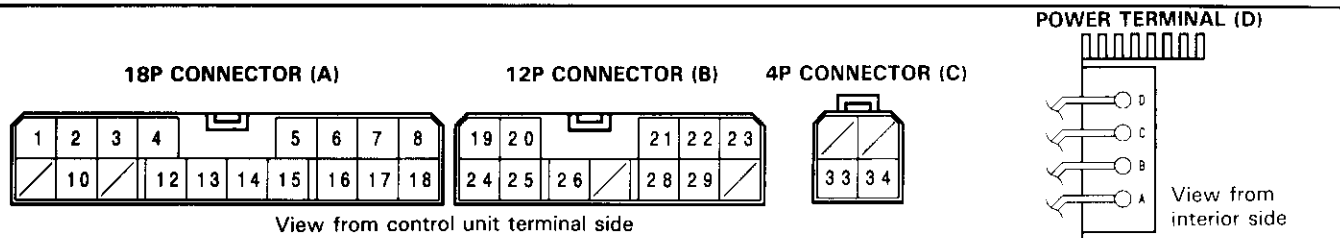

con- nector	con- nector No.	Wire color	Terminal name	Check				
				Measurement condition	Normal voltage	Measuremt terminals		
B	19	ORN	Vehicle speed sensor	While front wheel is being rotated slowly	5 V ↔ 0 V		19-24	
	20	GRN	Rear main steering angle sensor Z phase	While actuator motor is running slowly	5 V ↔ 0 V		20-24	
	21	YEL/BLK	Front sub steering angle sensor left	Analog tester AC range	Left	Center	Right	21-26
					3.0 V	2.5 V	2.0 V	
	22	YEL/BLU	Front sub steering angle sensor right	Analog tester AC range	Left	Center	Right	22-26
					2.0 V	2.5 V	3.0 V	
	23	PNK	Warning 2	Light ON	0 V		23-24	
				Light OFF	Battery voltage			
	24	BLK	Ground 1	IG SW ON	0 V		24-ground	
	25	YEL/RED	Ignition 1	IG SW ON	Battery voltage		25-24	
				IG SW OFF, ACC	0 V			
	26	YEL/GRN	Front sub steering angle sensor center	Analog tester DC range	approx. 2.5 V		26 24	
27	—	—	—	—		—		
28	GRY/BLK	Rear sub steering angle sensor left	Analog tester AC range	Left	Center	Right	28-17	
				2.0 V	2.5 V	3.0 V		
29	GRY	Rear sub steering angle sensor right	Analog tester AC range	Left	Center	Right	29-17	
				3.0 V	2.5 V	2.0 V		
30	—	—	—	—		—		
31	—	—	—	—		—		
32	—	—	—	—		—		
C	33	YEL	Damper	Resistance range Disconnect 4P connector. Start the engine	Continuity		33-34 control unit terminal	
	34	BLU	Damper		Momentarily open, no continuity			
D	A	WHT	Motor power source	At all times	Battery voltage		A-ground	
	B	BRN	power (motor) ground	IG SW ON	0 V		B-ground	
	C	RED	Motor terminal	Start the engine	0 V		C-ground	
	D	BLK	Motor terminal		Battery voltage		D-ground	

The normal voltage is the value when the system is working properly.

Troubleshooting (4WS)

Diagnostic Trouble Code (DTC)

To display the Diagnostic Trouble Code (DTC)

- (1) Pull out the service check connector (2P) located behind the center console and connect the two terminals of the connector with a jumper wire.

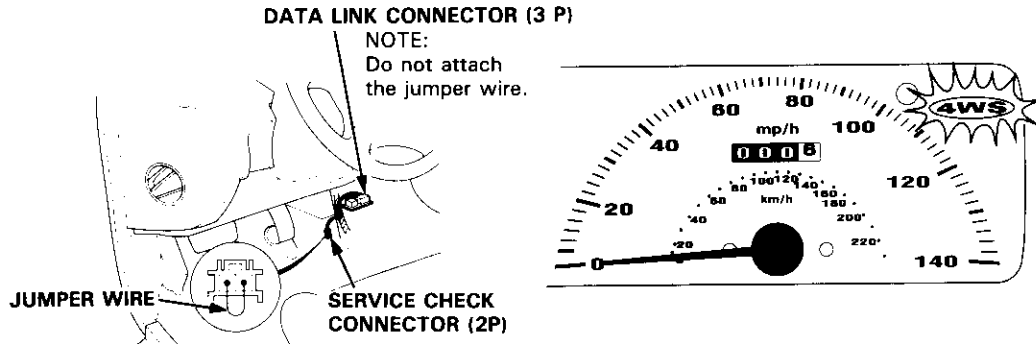

- (2) Turn the ignition switch ON, but do not start the engine.
- (3) Watch as the 4WS indicator light blinks to display the code.
- (4) Record the codes.

NOTE:

- Be sure to record the code. If you do any of the following, the code will be erased.
 - Disconnect the battery terminals.
 - Remove No. 43 CLOCK RADIO (10 A) fuse from the under-hood fuse/relay box.
 - Disconnect the 4WS control unit connector.

- If the engine is started with the service connector jumped, the Malfunction Indicator Lamp (MIL) will stay on.

DTC indication pattern

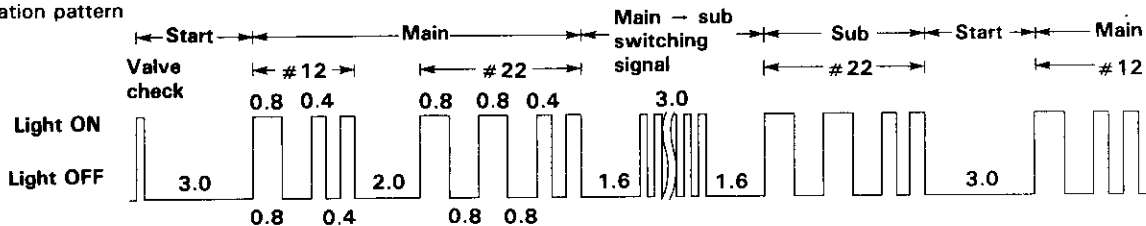

The 4WS indicator light displays a code by a series of long and short blinks. This indicator light can display multiple component problems by blinking separate codes, one after another. The number of long blinks equals the first digit of the code, the number of short blinks equals the second digit. When there are multiple codes, there is a two second pause between the codes.

System problems can be detected by both the main and sub central processing units (CPUs) in the 4WS control unit. Each CPU can memorize up to 10 codes. If both CPUs have stored codes, the 4WS indicator light will:

- Blink quickly once as an indicator light check, (this happens only when the ignition switch is first turned on).
- Pause for three seconds.
- Display the codes stored in the main CPU.
- Pause for 1.6 seconds.
- Blink rapidly for three seconds to indicate the switch between the main and sub CPU.
- Pause for 1.6 seconds.
- Display the codes stored in the sub CPU.
- Pause for three seconds, then repeat the cycle.

This cycle will continue until the ignition is turned OFF.

NOTE:

- Be sure to check both CPUs for at least 10 codes before turning OFF the ignition switch.
- If the main and sub CPUs display the same codes, those codes need only be checked once.



Precautions

Diagnostic Trouble Code (DTC):

The DTC is memorized when the 4WS control unit detects an abnormality, even if it was a temporary condition. To troubleshoot, ask the customer in detail about the conditions when the 4WS indicator light came on, and try to duplicate those conditions during the test drive. If the 4WS indicator light does not come on during the test drive, do not continue to troubleshoot; the system is OK at this time. The troubleshooting procedures assume that the symptom is occurring. Check for loose connections or poor contacts at the connectors by wiggling the harness, etc.

4WS Indicator:

The 4WS indicator light comes on when the 4WS control unit detects a problem in the system. Depending on the problem, the 4WS indicator light may be canceled by turning the ignition switch off, or it might require removing the CLOCK, RADIO (10 A) fuse in the under-hood fuse/relay box. If a problem is detected in the main steering angle sensor system, you must remove the CLOCK, RADIO (10 A) fuse to cancel the 4WS indicator light. If a problem is detected in any other part of the system, turning the ignition switch off will cancel the 4WS indicator light.

NOTE: If the 4WS light comes on because of a temporary problem in the main steering angle sensor system, it cannot be canceled by simply removing the cause of the problem and cycling the ignition switch; the CLOCK, RADIO (10 A) fuse must be removed.

The 4WS indicator light does not come on when the DTC is 71, 72, or 73. However, the 4WS indicator light will flash these codes when the service check connector is jumped.

Temporary Driving conditions:

When the vehicle is operated under extremely harsh or abnormal conditions, the 4WS control unit interprets it as a problem and memorizes the DTC.

DTC	Operation	4WS Indicator Light
70	The ignition is turned from OFF to ON while driving.	ON
71	The car is driven aggressively with the driver and three passengers on board, or the steering wheel is turned with a rear wheel blocked by the curb, etc.	—
73	The engine is started while quick-charging the battery.	—
74	Driving the car with the parking brake ON.	ON 5 minutes after detection

Fail-safe control:

When the fail-safe conditions are met, the 4WS control unit stops the 4WS control and returns the rear wheels to the straight driving position slowly.

Troubleshooting (4WS)

Symptom-to-System Chart

DIAGNOSTIC TROUBLE CODE (DTC)	FAIL-SAFE (F/S) ITEM			AFFECTED													ACTION	REFERENCE PAGE		
	SYSTEM	POINT	4WS CONTROL UNIT TERMINAL NUMBER	FRONT SUB STEERING ANGLE SENSOR	REAR SUB STEERING ANGLE SENSOR	FRONT MAIN STEERING ANGLE SENSOR	REAR MAIN STEERING ANGLE SENSOR	FRONT WHEEL SPEED SENSOR	REAR LEFT WHEEL SPEED SENSOR	REAR RIGHT WHEEL SPEED SENSOR	ABS CONTROL UNIT	4WS CONTROL UNIT	REAR ACTUATOR MOTOR	POWER SYSTEM HARNESS	ALTERNATOR	PARKING BRAKE			HARNESS CONNECTOR	
No code	-	—	7 + 23									○					○	Go to troubleshooting	17-42	
No code	-	—	18 25 4 2 16 + 24									○			○		○	Go to troubleshooting	17-42	
10	SUB STEERING ANGLE SENSOR	FRONT	22 26	○								○					○	Go to troubleshooting	17-45	
11		REAR	29 17		○								○					○	Go to troubleshooting	17-50
12		FRONT	26 21	○									○					○	Go to troubleshooting	17-45
13		REAR	17 28		○								○					○	Go to troubleshooting	17-50
14		FRONT	—										○						Replace 4WS control unit	—
15		REAR	—										○						Replace 4WS control unit	—
16		FRONT	22 26 21	○									○					○	Go to troubleshooting	17-45
17		REAR	29 17 28		○								○					○	Go to troubleshooting	17-50
18		—	—										○						Replace 4WS control unit	—



DIAGNOSTIC TROUBLE CODE (DTC)	FAIL-SAFE (F/S) ITEM			AFFECTED													ACTION	REFERENCE PAGE		
	SYSTEM	POINT	4WS CONTROL UNIT TERMINAL NUMBER	FRONT SUB STEERING ANGLE SENSOR	REAR SUB STEERING ANGLE SENSOR	FRONT MAIN STEERING ANGLE SENSOR	REAR MAIN STEERING ANGLE SENSOR	FRONT WHEEL SPEED SENSOR	REAR LEFT WHEEL SPEED SENSOR	REAR RIGHT WHEEL SPEED SENSOR	ABS CONTROL UNIT	4WS CONTROL UNIT	REAR ACTUATOR MOTOR	POWER SYSTEM HARNESS	ALTERNATOR	PARKING BRAKE			HARNESS CONNECTOR	
20	MAIN STEERING ANGLE SENSOR	FRONT	8 15	○		○						○					○	Go to trouble-shooting	17-55	
21		REAR	6 13		○		○					○					○	Go to trouble-shooting	17-59	
22		FRONT	8 15	○		○						○						○	Go to trouble-shooting	17-55
23		REAR	6 13		○		○					○						○	Go to trouble-shooting	17-59
24		FRONT	8 15	○		○						○						○	Go to trouble-shooting	17-55
25		REAR	6 13		○		○					○						○	Go to trouble-shooting	17-59
26		FRONT	—									○							Replace 4WS control unit	—
27		REAR	—									○							Replace 4WS control unit	—
28		FRONT	12	○		○						○						○	Go to trouble-shooting	17-55
29		REAR	20		○		○					○						○	Go to trouble-shooting	17-59
30	WHEEL SPEED	FRONT	19					○			○						○	Go to trouble-shooting	17-63	
31		REAR L	3						○		○	○					○	Go to trouble-shooting	17-64	
32		REAR R	1							○	○	○					○	Go to trouble-shooting	17-66	

(cont'd)

Troubleshooting (4WS)

Symptom-to-System Chart (cont'd)

DIAGNOSTIC TROUBLE CODE (DTC)	FAIL-SAFE (F/S) ITEM			AFFECTED													ACTION	REFERENCE PAGE		
	SYSTEM	POINT	4WS CONTROL UNIT TERMINAL NUMBER	FRONT SUB STEERING ANGLE SENSOR	REAR SUB STEERING ANGLE SENSOR	FRONT MAIN STEERING ANGLE SENSOR	REAR MAIN STEERING ANGLE SENSOR	FRONT WHEEL SPEED SENSOR	REAR LEFT WHEEL SPEED SENSOR	REAR RIGHT WHEEL SPEED SENSOR	ABS CONTROL UNIT	4WS CONTROL UNIT	REAR ACTUATOR MOTOR	POWER SYSTEM HARNESS	ALTERNATOR	PARKING BRAKE			HARNESS CONNECTOR	
33	WHEEL SPEED	REAR R/L	3 1								○	○					○	Go to troubleshooting	17-68	
34		FRONT	19					○				○					○	Go to troubleshooting	17-63	
35		REAR L	3						○		○	○						○	Go to troubleshooting	17-64
36		REAR R	1							○	○	○						○	Go to troubleshooting	17-66
37		REAR L	—									○							Replace 4WS control unit	—
38		VEHICLE SPEED	—									○							Replace 4WS control unit	—
40		4WS CONTROL UNIT	4WS CONTROL UNIT	—								○							Replace 4WS control unit	—
41			4WS CONTROL UNIT	—								○							Replace 4WS control unit	—
42	4WS CONTROL UNIT		—									○						Replace 4WS control unit	—	
43	4WS CONTROL UNIT		—									○							Replace 4WS control unit	—
44	4WS CONTROL UNIT		—									○							Replace 4WS control unit	—
45	4WS CONTROL UNIT		—									○							Replace 4WS control unit	—
46	4WS CONTROL UNIT		—									○							Replace 4WS control unit	—
50	CONTROL LOGIC	Motor lock	C + D -								○	○					○	Go to troubleshooting	17-70	
51		Wheel caught in ditch. Motor malfunction	C + D -									○	○					○	Go to troubleshooting	17-71



DIAGNOSTIC TROUBLE CODE (DTC)	FAIL-SAFE (F/S) ITEM			AFFECTED													ACTION	REFERENCE PAGE		
	SYSTEM	POINT	4WS CONTROL UNIT TERMINAL NUMBER	FRONT SUB STEERING ANGLE SENSOR	REAR SUB STEERING ANGLE SENSOR	FRONT MAIN STEERING ANGLE SENSOR	REAR MAIN STEERING ANGLE SENSOR	FRONT WHEEL SPEED SENSOR	REAR LEFT WHEEL SPEED SENSOR	REAR RIGHT WHEEL SPEED SENSOR	ABS CONTROL UNIT	4WS CONTROL UNIT	REAR ACTUATOR MOTOR	POWER SYSTEM HARNESS	ALTERNATOR	PARKING BRAKE			HARNESS CONNECTOR	
60	POWER UNIT	MOTOR	C+•D- 33+•34-									○	○	○			○	Go to troubleshooting	17-71	
61			C+•D-									○	○	○			○	Go to troubleshooting	17-71	
62		Motor	33+•34-										○	○	○			○	Go to troubleshooting	17-71
63													○	○	○			○	Go to troubleshooting	17-71
64		4WS CONTROL UNIT	—										○						Replace 4WS control unit	—
65		4WS CONTROL UNIT	—										○						Replace 4WS control unit	—
70	TEMPORARY DRIVING CONDITIONS	—	25									○					○	Ask customer for symptoms, conditions	—	
71		—	—									○						Ask customer for symptoms, conditions	—	
72		—	4										○					○	Ask customer for symptoms, conditions	—
73		—											○			○			Ask customer for symptoms, conditions	—
74		—	14										○			○		○	Ask customer for symptoms, conditions	—

Troubleshooting (4WS)

4WS Indicator Light Circuit

4WS CONTROL UNIT 18P/12P CONNECTORS

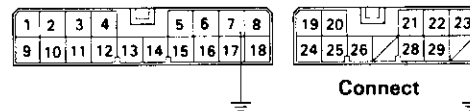

View from terminal side.

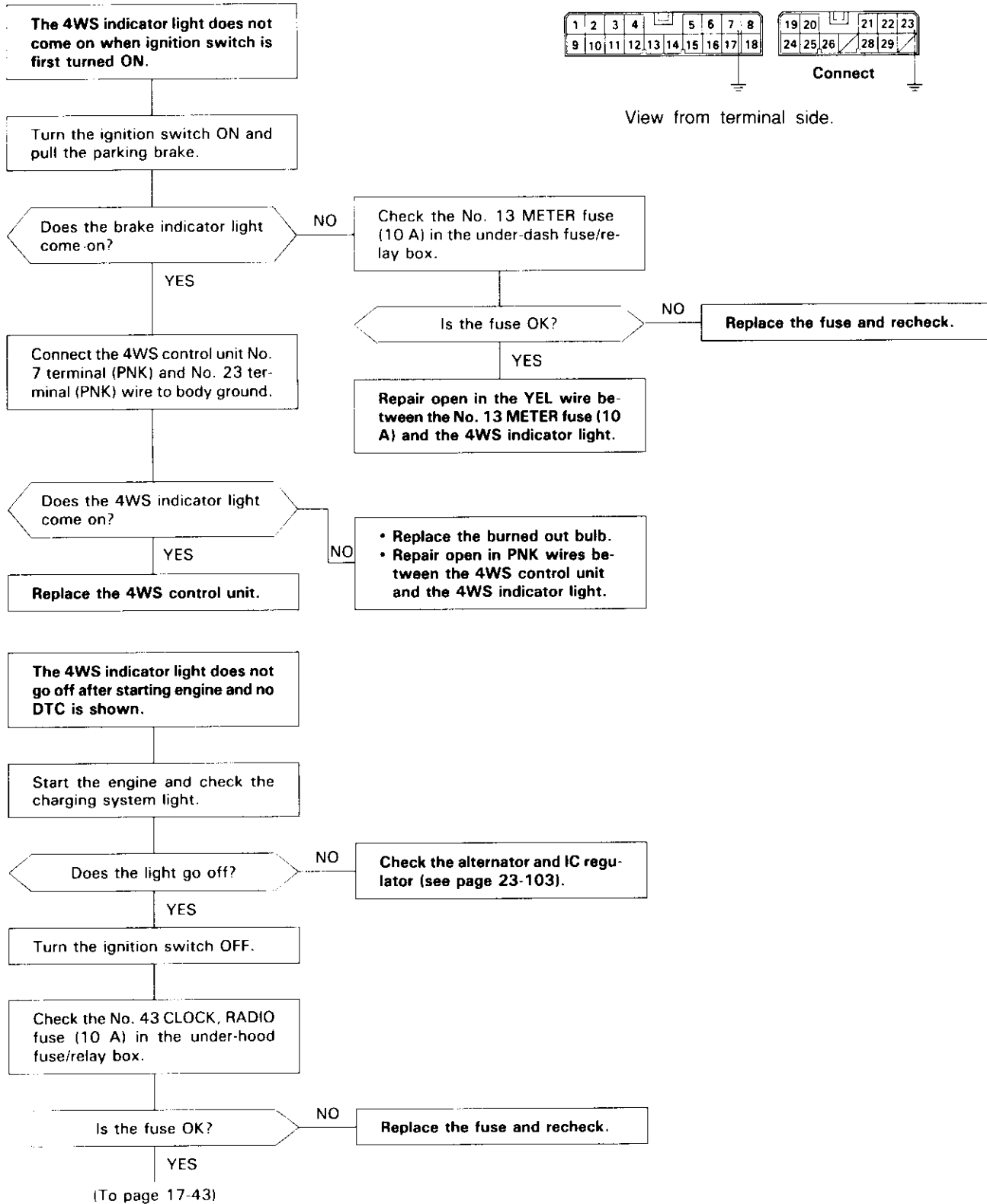



(From page 17-42)

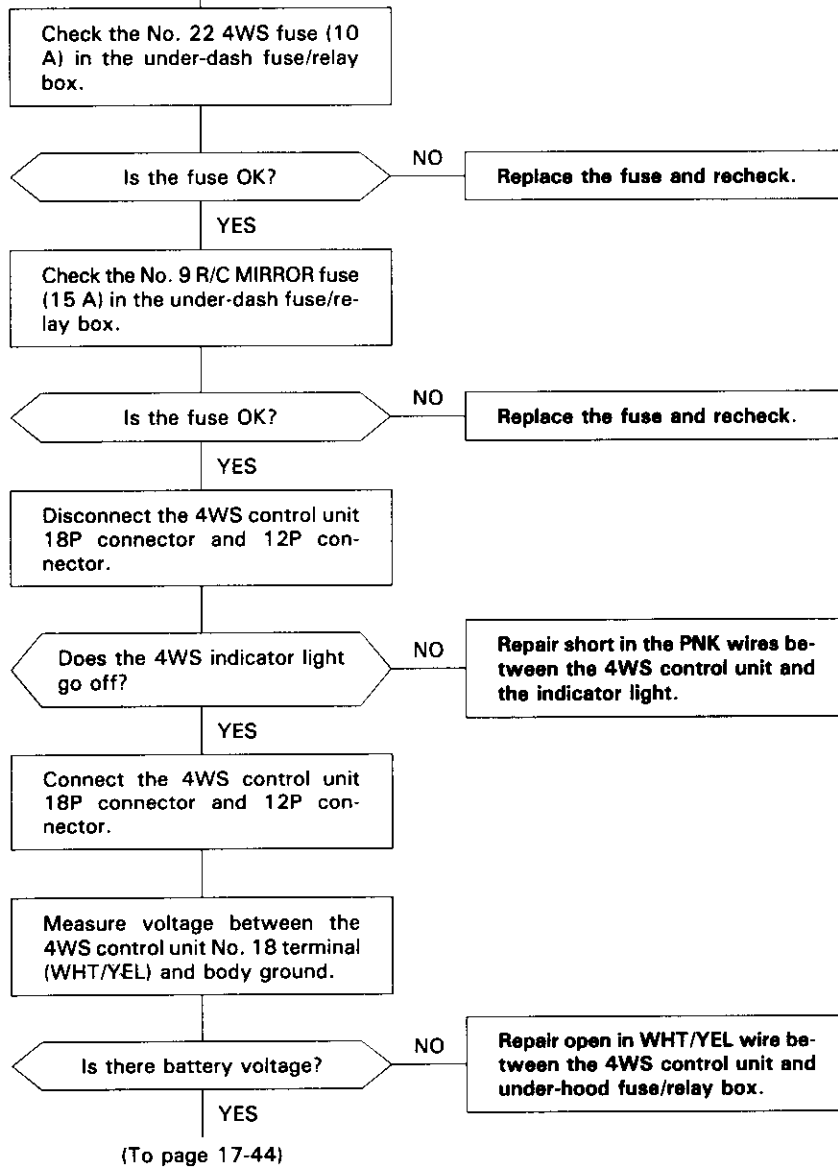

4WS CONTROL UNIT 18P CONNECTOR

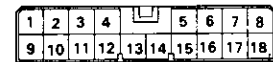

Battery Voltage?
View from terminal side.

Troubleshooting (4WS)

4WS Indicator Light Circuit (cont'd)

(From page 17-43)

Measure voltage between the 4WS control unit terminals: No. 18 (WHT/YEL) and No. 16 (BLK), and between No. 18 (WHT/YEL) and No. 24 (BLK).

Is there battery voltage?

NO

Repair the poor ground (G501) or open in BLK wire between the 4WS control unit and body ground.

YES

Turn the ignition switch ON.

Measure voltage between the 4WS control unit No. 25 terminal (YEL/RED) and body ground.

Is there battery voltage?

NO

Repair open in the YEL/RED wire between the 4WS control unit and under-dash fuse/relay box.

YES

Measure voltage between the 4WS control unit No. 4 terminal (BLK/YEL) and body ground.

Is there battery voltage?

NO

Repair open in the BLK/YEL wire between the 4WS control unit and the under-dash fuse/relay box.

YES

Start the engine.

Measure voltage between the 4WS control unit No. 2 terminal (WHT/BLU) and body ground.

Is there battery voltage?

NO

Repair open in the WHT/BLU wire between the 4WS control unit and the under-dash fuse/relay box.

YES

Replace the 4WS control unit.

4WS CONTROL UNIT CONNECTOR

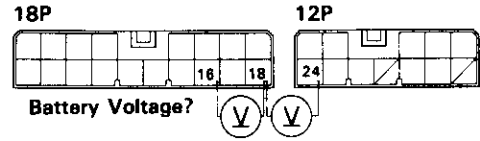

View from terminal side.

4WS CONTROL UNIT CONNECTOR

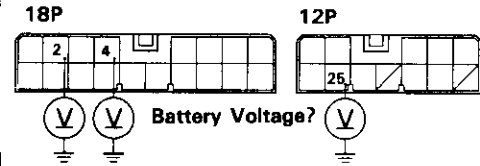

View from terminal side.



Diagnostic Trouble Codes (DTCs): 10, 12, 16

–The 4WS indicator light has been reported on.
–With service check connector jumped codes 10, 12, 16 are indicated.

Disconnect the front sub steering angle sensor connector.

Measure resistance between the No. 1 terminal (BLK) and No. 2 terminal (WHT/BLU) of the sensor side connector.

Is there 8.4 – 12.2 Ω ? NO **Replace the front sub steering angle sensor.**

YES

Measure resistance between the No. 2 terminal (WHT/BLU) and No. 3 terminal (BLK/WHT) of the sensor side connector.

Is there 8.4 – 12.2 Ω ? NO **Replace the front sub steering angle sensor.**

YES

Check for continuity between the sensor side connector No. 1 terminal (BLK) and body ground.

Is there continuity? YES **Replace the front sub steering angle sensor**

NO

Turn the ignition switch ON.

(To page 17-46)

FRONT SUB STEERING ANGLE SENSOR
SENSOR SIDE CONNECTOR

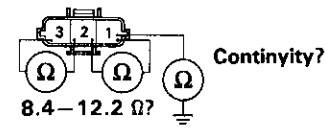

View from terminal side.

Troubleshooting (4WS)

Diagnostic Trouble Codes (DTCs): 10, 12, 16 (cont'd)

(From page 17-45)

Measure the voltage between the 4WS control unit side of the sensor connector No. 1 terminal (YEL/BLK) and body ground.

Is there approximately 2.5 V?

NO

Disconnect the 4WS control unit 12P connector.

YES

Check for continuity between the 4WS control unit No. 21 terminal (YEL/BLK) and body ground.

Is there continuity?

NO

Connect the 4WS control unit 12P connector.

Measure voltage between the No. 21 terminal (YEL/BLK) of the 4WS control unit and body ground.

Is there approximately 2.5 V?

YES

Repair open in the YEL/BLK wire between the 4WS control unit and the front sub steering angle sensor.

FRONT SUB STEERING ANGLE SENSOR
4WS CONTROL UNIT SIDE CONNECTOR

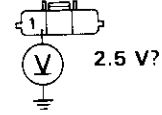

View from terminal side.

4WS CONTROL UNIT 12P SENSOR SIDE CONNECTOR

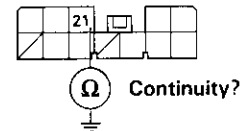

View from terminal side.

Repair short in the YEL/BLK wire between the 4WS control unit and the front sub steering angle sensor.

4WS CONTROL UNIT 12P CONNECTOR

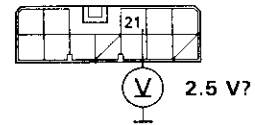

View from terminal side.

NO

Replace the 4WS control unit.

(To page 17-47)



(From page 17-46)

Measure the voltage between the 4WS control unit side of the sensor connector No. 2 terminal (YEL/GRN) and body ground.

Is there approximately 1.25 V?

YES

NO

Disconnect the 4WS control unit 12P connector.

Check for continuity between the 4WS control unit No. 26 terminal (YEL/GRN) and body ground.

Is there continuity?

NO

Connect the 4WS control unit 12P connector.

Measure voltage between the 4WS control unit No. 26 terminal (YEL/GRN) and body ground.

Is there approximately 1.25 V?

YES

Repair open in the YEL/GRN wire between the 4WS control unit and the front sub steering angle sensor.

**FRONT SUB STEERING ANGLE SENSOR
4WS CONTROL UNIT SIDE CONNECTOR**

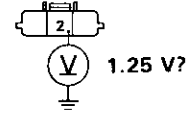

View from terminal side.

4WS CONTROL UNIT 12P SENSOR SIDE CONNECTOR

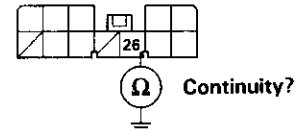

View from terminal side.

Repair short in the YEL/GRN wire between the 4WS control unit and the sub steering angle sensor.

4WS CONTROL UNIT 12P CONNECTOR

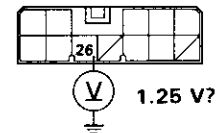

View from terminal side.

Replace the 4WS control unit.

(To page 17-48)

Troubleshooting (4WS)

Diagnostic Trouble Codes (DTCs): 10, 12, 16 (cont'd)

(From page 17-47)

Measure the voltage between the 4WS control unit side of the sensor connector No. 3 terminal (YEL/BLU) and body ground.

FRONT SUB STEERING ANGLE SENSOR
4WS CONTROL UNIT SIDE CONNECTOR

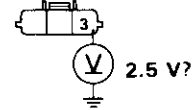

View from terminal side.

Is there approximately 2.5 V?

NO

Disconnect the 4WS control unit 12P connector.

4WS CONTROL UNIT 12P SENSOR SIDE CONNECTOR

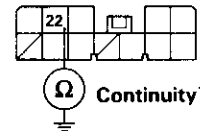

View from terminal side.

YES

Check for continuity between the 4WS control unit No. 22 terminal (YEL/BLU) and body ground.

Is there continuity?

YES

Repair short in the YEL/BLU wire between the 4WS control unit and sub steering angle sensor.

NO

Connect the 4WS control unit 12P connector.

4WS CONTROL UNIT 12P CONNECTOR

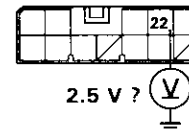

View from terminal side.

Measure voltage between the 4WS control unit No. 22 terminal (YEL/BLU) and body ground.

Is there approximately 2.5 V?

NO

Replace the 4WS control unit.

YES

Repair open in the YEL/BLU wire between the 4WS control unit and the front sub steering angle sensor.

(To page 17-49)



(From page 17-48)

Connect the front sub steering angle sensor connector.

Start the engine.

While turning the steering wheel, measure voltage between No. 22 (YEL/BLU) and No. 26 (YEL/GRN) terminals of the 4WS control unit using AC range of analog tester.

4WS CONTROL UNIT 12P CONNECTOR

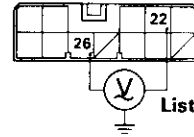

Listed Voltage?

View from terminal side.

FRONT SUB STEERING ANGLE SENSOR TERMINAL VOLTAGE (REFERENCE)

STEERING WHEEL POSITION	LEFT	CENTER	RIGHT
Voltage	approx 2.0 V	approx 2.5 V	approx 3.0 V

Analog tester AC range

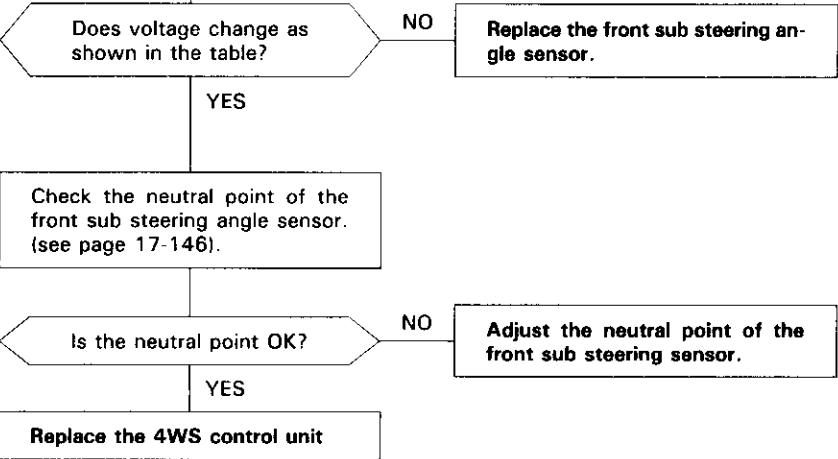

Troubleshooting (4WS)

Diagnostic Trouble Codes (DTCs): 11, 13, 17

—The 4WS indicator light has been reported on.
—With service check connector jumped codes 11, 13, 17 are indicated.

Disconnect the rear sub steering angle sensor connector.

Measure resistance between the No. 1 terminal (BLK/WHT), and the No. 2 terminal (WHT/BLU) of the sensor side connector.

Is there 8.4–12.2 Ω ?

NO

Replace the rear sub steering angle sensor.

YES

Measure resistance between the No. 2 terminal (BLK/WHT), and the No. 3 terminal (BLK) of the sensor side connector.

Is there 8.4–12.2 Ω ?

NO

Replace the rear sub steering angle sensor.

YES

Check for continuity between the sensor side connector No. 3 terminal (BLK) and ground.

Is there continuity?

YES

Replace the rear sub steering angle sensor.

NO

Turn the ignition switch ON.

(To page 17-51)

REAR SUB STEERING ANGLE SENSOR SENSOR SIDE CONNECTOR

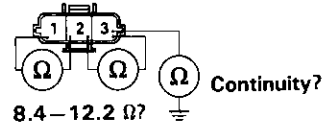

View from terminal side.



(From page 17-50)

Measure the voltage between the 4WS control unit side of the sensor connector No. 1 terminal (GRY) and body ground.

**REAR SUB STEERING ANGLE SENSOR
4WS CONTROL UNIT SIDE CONNECTOR**

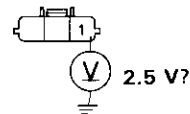

View from terminal side.

Is there approximately 2.5 V?

NO

Disconnect the 4WS control unit 12P connector.

4WS CONTROL UNIT 12P SENSOR SIDE CONNECTOR

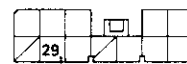

View from terminal side.

Check for continuity between the 4WS control unit No. 29 terminal (GRY) and body ground.

Is there continuity?

YES

Repair short in the GRY wire between the 4WS control unit and the rear sub steering angle sensor.

NO

Connect the 4WS control unit 12P connector.

4WS CONTROL UNIT 12P CONNECTOR

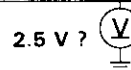

View from terminal side.

Measure voltage between the 4WS control unit No. 29 terminal (GRY) and body ground.

Is there approximately 2.5 V?

NO

Replace 4WS control unit.

YES

Repair open in the GRY wire between the 4WS control unit and the rear sub steering angle sensor.

(To page 17-52)

Troubleshooting (4WS)

Diagnostic Trouble Codes (DTCs): 11, 13, 17 (cont'd)

(From page 17-51)

Measure the voltage between the 4WS control unit side of the sensor connector No. 2 terminal (GRY/YEL) wire and body ground.

REAR SUB STEERING ANGLE SENSOR 4WS CONTROL UNIT SIDE CONNECTOR

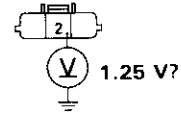

View from terminal side.

Is there approximately 1.25 V?

NO

Disconnect the 4WS control unit 18P connector.

4WS CONTROL UNIT 18P SENSOR SIDE CONNECTOR

Check for continuity between the 4WS control unit No. 17 terminal (GRY/YEL) and body ground.

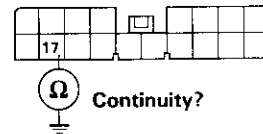

View from terminal side.

Is there continuity?

YES

Repair short in the GRY/YEL wire between the 4WS control unit and the rear sub steering angle sensor.

NO

Connect the 4WS control unit 18P connector.

4WS CONTROL UNIT 18P CONNECTOR

Measure voltage between the 4WS control unit No. 17 terminal (GRY/YEL) and body ground.

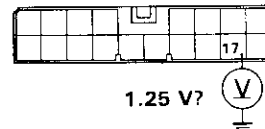

View from terminal side.

Is there approximately 1.25 V?

NO

Replace the 4WS control unit.

YES

Repair open in the GRY/YEL wire between the 4WS control unit and the rear sub steering angle sensor.

(To page 17-53)



(From page 17-52)

REAR SUB STEERING ANGLE SENSOR 4WS CONTROL UNIT SIDE CONNECTOR

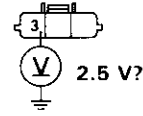

View from terminal side.

Measure the voltage between the 4WS control unit side of the sensor connector No. 3 terminal (GRY/BLK) and body ground.

Is there approximately 2.5 V?

NO

Disconnect the 4WS control unit 12P connector.

YES

4WS CONTROL UNIT 12P SENSOR SIDE CONNECTOR

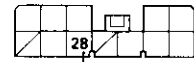

View from terminal side.

Check for continuity between the 4WS control unit No. 28 terminal (GRY/BLK) and body ground.

Is there continuity?

YES

Repair short in the GRY/BLK wire between the 4WS control unit and the rear sub steering angle sensor.

NO

Connect the 4WS control unit 12P connector.

4WS CONTROL UNIT 12P CONNECTOR

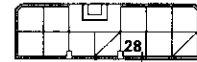

View from terminal side.

Measure voltage between the 4WS control unit No. 28 terminal (GRY/BLK) and body ground.

Is there approximately 2.5 V?

NO

Replace 4WS control unit.

YES

Repair open in the GRY/BLK wire between the 4WS control unit and the rear sub steering angle sensor.

(To page 17-54)

Troubleshooting (4WS)

Diagnostic Trouble Codes (DTCs): 11, 13, 17 (cont'd)

(From page 17-53)

Connect the rear sub steering angle sensor connector.

Start the engine.

While turning the steering wheel and measure voltage between No. 17 (GRY/YEL) and No. 29 (GRY) terminals of the 4WS control unit using AC range of an analog tester.

4WS CONTROL UNIT 18P/12P CONNECTOR

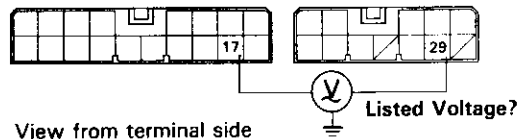

REAR SUB STEERING ANGLE SENSOR TERMINAL VOLTAGE (REFERENCE)

STEERING WHEEL POSITION	LEFT	CENTER	RIGHT
Voltage	approx 3.0 V	approx 2.5 V	approx 2.0 V

Analog tester AC range

Does voltage change as shown in the table?

NO

Replace the rear sub steering angle sensor.

YES

Check the neutral point of the rear sub steering angle sensor (see page 17-146).

Is the neutral point OK?

NO

Adjust the neutral point of the rear sub steering sensor.

YES

Replace the 4WS control unit



Diagnostic Trouble Codes (DTCs): 20, 22, 24, 28

-The 4WS indicator light has been reported on.
-With service check connector jumped codes 20, 22, 24, 28 are indicated.

Disconnect the front main steering angle sensor connector.

Turn the ignition switch ON.

Measure voltage between the 4WS control unit side connector No. 1 terminal (BLK/YEL) and body ground.

Is there battery voltage?

NO
Repair open in the harness wire between the No. 22 4WS fuse and the front main steering angle sensor.

YES

Measure the voltage between the 4WS control unit side of the sensor connector No. 4 terminal (LT GRN) and body ground.

Is there approximately 4.5 V?

NO
Disconnect the 4WS control unit 18P connector.

YES

Check for continuity between the 4WS control unit No. 8 terminal (GRN) and body ground.

Is there continuity?

YES
Repair short in the GRN wire between the 4WS control unit and the main steering angle sensor.

NO

Connect the 4WS control unit 18P connector.

Measure voltage between the 4WS control unit No. 8 terminal (GRN) and body ground.

Is there approximately 4.5 V?

NO
Replace the 4WS control unit.

YES

Repair open in the GRN wire between the 4WS control unit and the front main steering angle sensor.

(To page 17-56)

FRONT MAIN STEERING ANGLE SENSOR 4WS CONTROL UNIT SIDE CONNECTOR

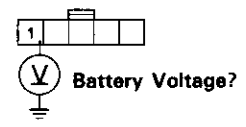

View from terminal side.

FRONT MAIN STEERING ANGLE SENSOR 4WS CONTROL UNIT SIDE CONNECTOR

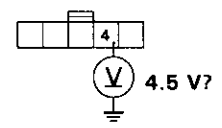

View from terminal side.

4WS CONTROL UNIT 18P SENSOR SIDE CONNECTOR

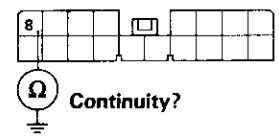

View from terminal side.

4WS CONTROL UNIT 18P CONNECTOR

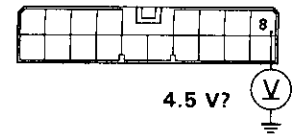

View from terminal side.

Troubleshooting (4WS)

Diagnostic Trouble Codes (DTCs): 20, 22, 24, 28 (cont'd)

(From page 17-55)

Measure the voltage between the 4WS control unit side of the sensor connector No.3 terminal (BLU) and body ground.

FRONT MAIN STEERING ANGLE SENSOR 4WS CONTROL UNIT SIDE CONNECTOR

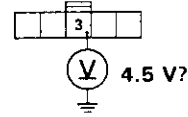

View from terminal side.

Is there approximately 4.5 V?

YES

NO

Disconnect the 4WS control unit 18P connector.

4WS CONTROL UNIT 18P SENSOR SIDE CONNECTOR

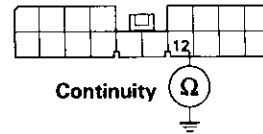

View from terminal side.

Check for continuity between the 4WS control unit No. 3 terminal (BLU) and body ground.

Is there continuity?

NO

YES

Repair short in the BLU wire between the 4WS control unit and the main steering angle sensor.

Connect the 4WS control unit 18P connector.

4WS CONTROL UNIT 18P CONNECTOR

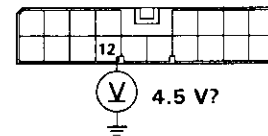

View from terminal side.

Measure voltage between the 4WS control unit No. 12 terminal (BLU) and body ground.

Is there approximately 4.5 V?

YES

NO

Replace the 4WS control unit.

(To page 17-57)

Repair open in the BLU wire between the 4WS control unit and the front main steering angle sensor.



(From page 17-56)

FRONT MAIN STEERING ANGLE SENSOR 4WS CONTROL UNIT SIDE CONNECTOR

Measure the voltage between the 4WS control unit side of the sensor connector No. 2 terminal (YEL/RED) wire and body ground.

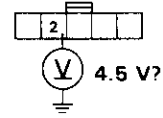

View from terminal side.

Is there approximately 4.5 V?

NO

Disconnect the 4WS control unit 18P connector.

4WS CONTROL UNIT 18P SENSOR SIDE CONNECTOR

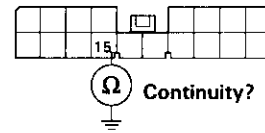

View from terminal side.

YES

Check for continuity between the 4WS control unit No. 15 terminal (YEL/RED) and body ground.

Is there continuity?

YES

Repair short in the YEL/RED wire between the 4WS control unit and the main steering angle sensor.

NO

Connect the 4WS control unit 18P connector.

4WS CONTROL UNIT 18P CONNECTOR

Measure voltage between the 4WS control unit No. 15 terminal (YEL/RED) and body ground.

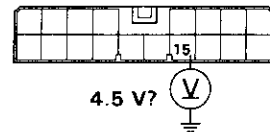

View from terminal side.

Is there approximately 4.5 V?

NO

Replace the 4WS control unit.

YES

Repair open in the YEL/RED wire between the 4WS control unit and the front main steering angle sensor.

(To page 17-58)

Troubleshooting (4WS)

Diagnostic Trouble Codes (DTCs): 20, 22, 24, 28 (cont'd)

(From page 17-57)

Check for voltage between the No. 2 terminal (YEL/RED) and the No. 5 terminal (BLK) of the 4WS control unit side connector of the front main steering angle sensor.

Is there approximately 4.5 V?

NO

Repair the poor ground (G 401, 402, 404) or open in the BLK wire between the front main steering angle sensor and body ground.

YES

Reconnect the front main steering angle sensor 5P connector.

While turning the steering wheel, check for the signals between the following 4WS control unit terminals and the body ground with an analog voltmeter on the DC range.

A-phase:
Between the No. 8 terminal (GRN) and body ground: should pulse 0 ↔ 4.5 V rapidly (every 2°)

B-phase:
Between the No. 15 terminal (YEL/RED) and body ground: should pulse 0 ↔ 4.5 V rapidly (every 2°)

Z-phase:
Between the No. 12 terminal (BLU) and body ground: should pulse 0 ↔ 4.5 V once per steering wheel revolution

Are the signals available between the respective terminal and the body ground?

NO

Replace the front main steering angle sensor.

YES

Check the Z-phase neutral position (see page 17-146).

Is the Z-phase in the straight driving position?

NO

Adjust the front main steering angle sensor neutral position (see page 17-15)

YES

Perform troubleshooting for DTCs 10, 12, 16. (see page 17-45).

FRONT MAIN STEERING ANGLE SENSOR 4WS CONTROL UNIT SIDE CONNECTOR

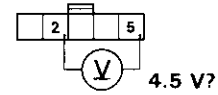

View from terminal side

4WS CONTROL UNIT 18P CONNECTOR

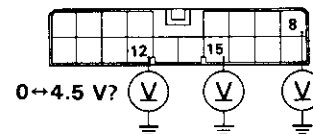

View from terminal side

Straight

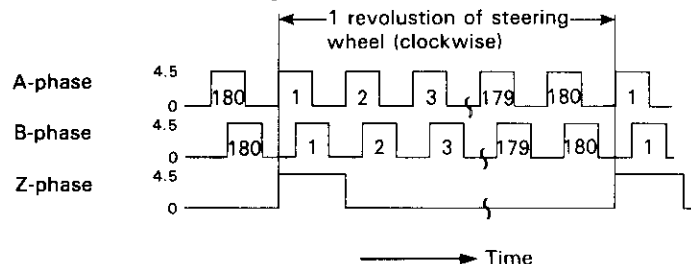



Diagnostic Trouble Codes (DTCs): 21, 23, 25, 29

-The 4WS indicator light has been reported on.
-With service check connector jumped codes 21, 23, 25, 29 are indicated.

Disconnect the rear main steering angle sensor connector.

Turn the ignition switch ON.

Measure voltage between the 4WS control unit side connector No. 1 terminal (RED) and body ground.

Is there battery voltage?

NO

Repair open in the harness wire between the No. 22 4WS fuse and the rear main steering angle sensor.

YES

Measure the voltage between the 4WS control unit side No.3 terminal (WHT/GRN) and body ground.

Is there approximately 4.5 V?

NO

Disconnect the 4WS control unit 18P connector.

YES

Check for continuity between the 4WS control unit No. 6 terminal (WHT/GRN) and body ground.

Is there continuity?

YES

Repair short in the WHT/GRN wire between the 4WS control unit and the main steering angle sensor.

NO

Connect the 4WS control unit 18P connector.

Measure voltage between the 4WS control unit No. 6 terminal (WHT/GRN) and body ground.

Is there approximately 4.5 V?

NO

4WS CONTROL UNIT 18P CONNECTOR

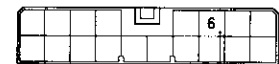

4.5 V?



View from terminal side

Replace the 4WS control unit.

YES

Repair open in the WHT/GRN wire between the 4WS control unit and the rear main steering angle sensor.

(To page 17-60)

REAR MAIN STEERING ANGLE SENSOR
4WS CONTROL UNIT SIDE CONNECTOR

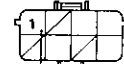

Battery voltage?

View from terminal side

REAR MAIN STEERING ANGLE SENSOR
4WS CONTROL UNIT SIDE CONNECTOR

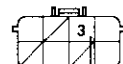

4.5 V?

View from terminal side

4WS CONTROL UNIT 18P
SENSOR SIDE CONNECTOR



Continuity?

View from terminal side

Troubleshooting (4WS)

Diagnostic Trouble Codes (DTCs): 21, 23, 25, 29 (cont'd)

(From page 17-59)

Measure the voltage between the 4WS control unit side No. 4 terminal (ORN) wire and body ground.

Is there approximately 4.5 V?

YES

NO

Disconnect the 4WS control unit 12P connector.

Check for continuity between the 4WS control unit No. 20 terminal (ORN) and body ground.

Is there continuity?

NO

Connect the 4WS control unit 12P connector.

Measure voltage between the 4WS control unit No. 20 terminal (ORN) and body ground.

Is there approximately 4.5 V?

YES

Repair open in the ORN wire between the 4WS control unit and the rear main steering angle sensor.

REAR MAIN STEERING ANGLE SENSOR 4WS CONTROL UNIT SIDE CONNECTOR

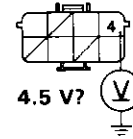

View from terminal side

4WS CONTROL UNIT 12P SENSOR SIDE CONNECTOR

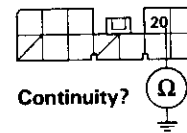

View from terminal side

Repair short in the ORN wire between the 4WS control unit and the rear main steering angle sensor.

4WS CONTROL UNIT 12P CONNECTOR

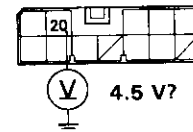

View from terminal side

Replace the 4WS control unit.

(To page 17-61)



(From page 17-60)

REAR MAIN STEERING ANGLE SENSOR 4WS CONTROL UNIT SIDE CONNECTOR

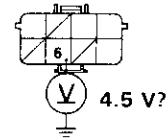

View from terminal side

Measure the voltage between the 4WS control unit side No. 6 terminal (BLU/GRN) and body ground.

Is there approximately 4.5 V?

NO

Disconnect the 4WS control unit 18P connector.

Check for continuity between the 4WS control unit No. 13 terminal (BLU/GRN) and body ground.

Is there continuity?

YES

Repair short in the BLU/GRN wire between the 4WS control unit and the rear main steering angle sensor.

NO

Connect the 4WS control unit 18P connector.

Measure voltage between the 4WS control unit No. 13 terminal (BLU/GRN) and body ground.

Is there approximately 4.5 V?

NO

Replace the 4WS control unit.

YES

Repair open in the BLU/GRN wire between the 4WS control unit and the rear main steering angle sensor.

4WS CONTROL UNIT 18P SENSOR SIDE CONNECTOR

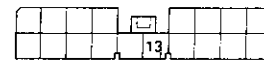

Continuity? Ω

View from terminal side

4WS CONTROL UNIT 18P CONNECTOR

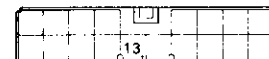

4.5 V?

View from terminal side

(To page 17-62)

Troubleshooting (4WS)

Diagnostic Trouble Codes (DTCs): 21, 23, 25, 29 (cont'd)

(From page 17-61)

Measure voltage between the No. 6 terminal (BLU/GRN) and the No. 8 terminal (RED) of the 4WS control unit side connector of the rear main steering angle sensor.

Is there approximately 4.5 V?

NO

Repair open in the RED wire between the 4WS control unit and the rear main steering angle sensor.

YES

Reconnect the rear main steering angle sensor 8P connector.

While turning the steering wheel, check for the signals between the following 4WS control unit terminals and the body ground with an analog voltmeter on the DC range.

A-phase:
Between the No. 6 terminal (WHT/GRN) and body ground: should pulse 0→4.5 V rapidly (every 2°)

B-phase:
Between the No. 13 terminal (BLU/GRN) and body ground: should pulse 0→4.5 V rapidly (every 2°)

Z-phase:
Between the No. 20 terminal (ORN) and body ground: should pulse 0→4.5 V once per steering wheel revolution

Are the signals available between the respective terminal and the body ground?

NO

Replace the rear main steering angle sensor.

YES

Check the Z-phase neutral position (see page 17-146).

Is the Z-phase in the straight driving position?

NO

Replace the rear actuator.

YES

Perform troubleshooting of the DTCs 11, 13, 17. (see page 17-50)

REAR MAIN STEERING ANGLE SENSOR
4WS CONTROL UNIT SIDE CONNECTOR

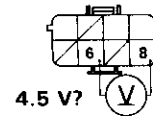

View from terminal side

4WS CONTROL UNIT 18P/12P
CONNECTOR

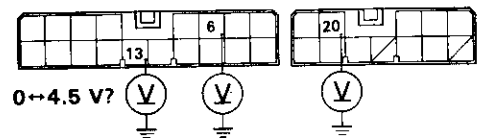

View from terminal side

Straight

A-phase

B-phase

Z-phase

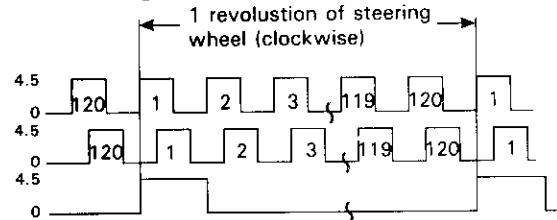



Diagnostic Trouble Codes (DTCs): 30, 34

vehicle speed sensor (VSS)

NOTE: DTC 34 may have been memorized on 4WS control unit after the using ALB checker.

If so, disconnect No. 43 CLOCK, RADIO (10 A) fuse in under-hood fuse/relay box to reset the 4WS control unit.

-The 4WS indicator light has been reported on.
-With service check connector jumped codes 30 and 34 are indicated.

Disconnect the No. 43 fuse (10 A) in the under-hood fuse/relay box.

Test drive the car.

Do codes 30 and 34 appear? NO System is OK at this time. Inspect the vehicle speed sensor terminal connectors.

YES Does the speedometer operate properly? NO (Go to page 23-118)

YES Disconnect the 4WS control unit 12P connector.

4WS CONTROL UNIT 12P SENSOR SIDE CONNECTOR

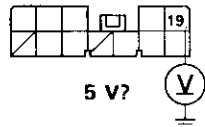

Turn the ignition switch ON.

Measure voltage between the No. 19 terminal (ORN) of sensor side connector of 4WS control unit and body ground.

View from terminal side

Is there more than 5 V? YES Replace the 4WS control unit (When the symptom recurred.)

NO Repair open or short in the ORN wire to body ground between the vehicle speed sensor and the 4WS control unit.

Troubleshooting (4WS)

Diagnostic Trouble Codes (DTCs): 31, 35 (cont'd)

– The 4WS indicator light has been reported on.
– With service check connector jumped codes 31 and 35 are indicated.

Start the engine.

Does the ABS indicator light stay ON? YES

Go to page 19-54
Problem in ABS system

NO

Stop the engine. Then turn the ignition switch back ON.

With the left rear wheel raised off ground, slowly rotate the wheel while checking for voltage between the 4WS control unit No. 3 terminal (GRY/WHT) and body ground.

Does the voltage alternate from zero to approximately 5 V? YES

Record the DTC and clear the 4WS control unit. Test drive the car, if the DTC does not reappear, check the terminal connections of the 4WS control unit 18P connector and the ABS control unit 14P connector.

NO

(To page 17-65)

4WS CONTROL UNIT 18P CONNECTOR

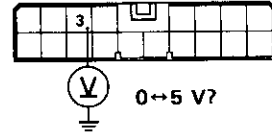

View from terminal side



(From page 17-64)

Turn the ignition switch OFF.

Disconnect the 4WS control unit connector and the ABS control unit connector.

Check for continuity between the 4WS control unit No. 3 terminal (GRY/WHT) and body ground.

Is there continuity?

YES

Repair short in the GRY/WHT wire between the 4WS control unit and the ABS control unit.

NO

Reconnect the 4WS control unit connector.

Turn the ignition switch ON.

Measure voltage between the No. 3 terminal of the 4WS control unit connector and body ground.

Is there approximately 5 V?

NO

Replace the 4WS control unit.

YES

Measure voltage between the No. 3 terminal (GRY/WHT) of sensor side connector of ABS control unit 14P connector and body ground.

Is there approximately 5V?

NO

Repair open in the GRY/WHT wire between the 4WS control unit and the ABS control unit.

YES

Replace the ABS control unit.

4WS CONTROL UNIT 18P SENSOR SIDE CONNECTOR

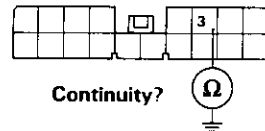

View from terminal side

4WS CONTROL UNIT 18P CONNECTOR

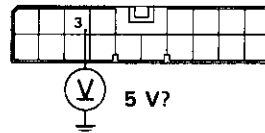

View from terminal side

ABS CONTROL UNIT 14P SENSOR SIDE CONNECTOR

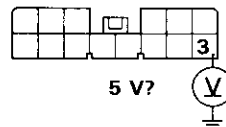

View from terminal side

Troubleshooting (4WS)

Diagnostic Trouble Codes (DTCs): 32, 36

– The 4WS indicator light has been reported on.
 – With service check connector jumped codes 32 and 36 are indicated.

Start the engine.

Does the ABS indicator light stay ON? **YES**

Go to page 19-54
 Problem in ABS system

NO

Stop the engine. Then turn the ignition switch back ON.

With the right rear wheel raised off the ground, slowly rotate the wheel while checking for voltage between the 4WS control unit No. 1 terminal (GRY/RED) and body ground.

Does the voltage alternate from zero to approximately 5 V? **YES**

Record the DTC and clear the 4WS control unit. Test drive the car, if the DTC does not reappear, check the terminal connections of the 4WS control unit 18P connector and the ABS control unit 14P connector.

NO

(To page 17-67)

4WS CONTROL UNIT 18P CONNECTOR

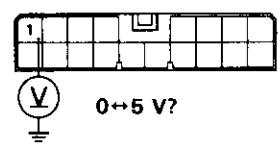

View from terminal side



(From page 17-66)

Turn the ignition switch OFF.

Disconnect the 4WS control unit connector and the ABS control unit connector.

Check for continuity between the 4WS control unit No. 1 terminal (GRY/RED) and body ground.

Is there continuity?

YES

Repair short in the GRY/RED wire between the 4WS control unit and the ABS control unit.

NO

Reconnect the 4WS control unit connector.

Turn the ignition switch ON.

Measure voltage between the No. 1 terminal (GRY/RED) of the 4WS control unit connector and body ground.

Is there approximately 5 V?

NO

Replace the 4WS control unit

YES

Measure voltage between the No. 1 terminal (GRY/RED) of sensor side connector of ABS control unit 14P connector and body ground.

Is there approximately 5V?

NO

Repair open in the GRY/RED wire between the 4WS control unit and the ABS control unit.

YES

Replace the ABS control unit.

4WS CONTROL UNIT 18P SENSOR SIDE CONNECTOR

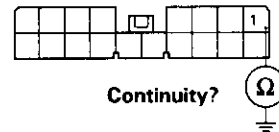

View from terminal side

4WS CONTROL UNIT 18P CONNECTOR

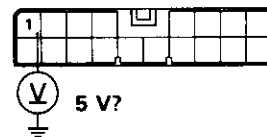

View from terminal side

ABS CONTROL UNIT 14P SENSOR SIDE CONNECTOR

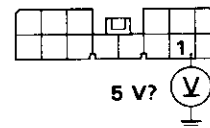

View from terminal side

Troubleshooting (4WS)

Diagnostic Trouble Code (DTC): 33

NOTE: Problem code 33 is memorized when the front wheels are turned at a speed of 30 km/h for 2 minutes with the front wheels raised off the ground and the rear wheels blocked. (Parking brake must be off to test this code.)

– The 4WS indicator light has been reported on.
– With service check connector jumped code 33 is indicated.

4WS CONTROL UNIT 18P CONNECTOR

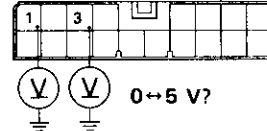

View from terminal side

Start the engine.

Does the ABS light stay ON? YES

Perform troubleshooting of the ABS system (page 19-54)

NO

Stop the engine. Then turn the ignition switch back ON.

Rotate the rear left wheel slowly and check for voltage between the 4WS unit control No. 1 terminal (GRY/RED) and body ground, and between the No. 3 terminal (GRY/WHT) and body ground.

Does the voltage from both rear wheel sensors alternate from zero to approximately 5 V? YES

Record the DTC and clear the 4WS control unit. Test drive the car, if the DTC does not reappear, check the terminals connections of the 4WS control unit 18P connector and the ABS control unit 14P connector.

NO

(To page 17-69)



(From page 17-68)

Disconnect the 4WS control unit connector and the ABS control unit connector.

Check for continuity between the 4WS control unit No. 1 terminal (GRY/RED) and body ground.

Is there continuity?

YES

Repair short in the GRY/RED wire between 4WS control unit and the ABS control unit.

NO

Check for continuity between the 4WS control unit No. 3 terminal (GRY/WHT) and body ground.

Is there continuity?

YES

Repair short in the GRY/WHT wire between the 4WS control unit and the ABS control unit.

NO

Reconnect the 4WS control unit connector.

Measure voltage between the 4WS control unit No. 1 terminal (GRY/RED) and body ground.

Is there approximately 5 V?

NO

Replace the 4WS control unit.

YES

(To page 17-70)

4WS CONTROL UNIT 18P SENSOR SIDE CONNECTOR

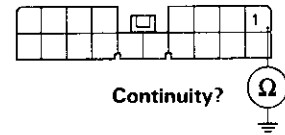

View from terminal side

4WS CONTROL UNIT 18P SENSOR SIDE CONNECTOR

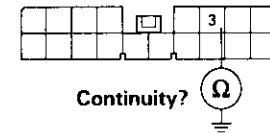

View from terminal side

4WS CONTROL UNIT 18P CONNECTOR

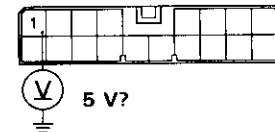

View from terminal side

Troubleshooting (4WS)

Diagnostic Trouble Code (DTC): 33 (cont'd) – Diagnostic Trouble Code (DTC): 50

(From page 17-69)

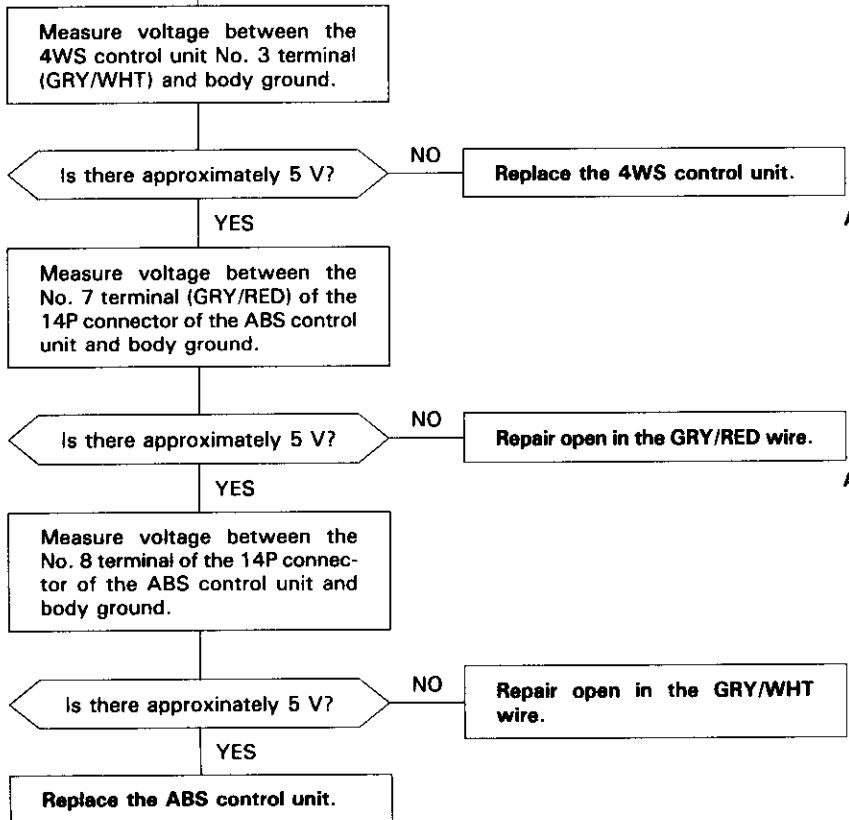

4WS CONTROL UNIT 18P CONNECTOR

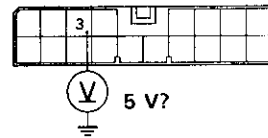

View from terminal side

ABS CONTROL UNIT 14P CONNECTOR

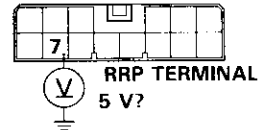

View from terminal side

ABS CONTROL UNIT 14P CONNECTOR

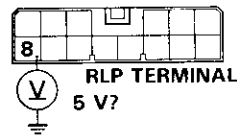

View from interior side

REAR ACTUATOR MOTOR TERMINAL

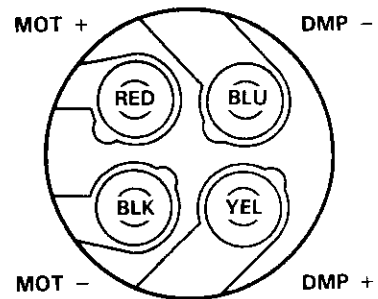

Diagnostic Trouble Code (DTC): 50

- The 4WS indicator light has been reported on.
- With service check connector jumped code 50 is indicated.

Start the engine. Turn the steering wheel and check the rear steering motor for function.

Does it operate properly?

YES

Clear the 4WS control unit and retest, if the DTC reoccurs, then replace the control unit.

NO

Replace the rear actuator motor.

4WS CONTROL UNIT POWER TERMINAL

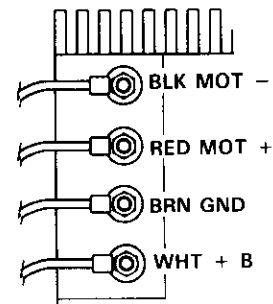

View from terminal side



Diagnostic Trouble Code (DTC): 51 – Diagnostic Trouble Codes (DTCs): 60, 61, 62, 63

Diagnostic Trouble Code (DTC): 51

– The 4WS indicator light has been reported on.
– With service check connector jumped code 51 is indicated.

Start the engine. Turn the steering wheel and check the rear steering motor for function.

Does it operate properly?

YES

The DTC 51 blinks when the rear wheels cannot be steered because they are blocked with the curb, etc. If the DTC 51 blinks after the test drive, the control unit is faulty.

NO

Replace the rear actuator motor.

Diagnostic Trouble Codes (DTCs): 60, 61, 62, 63

– The 4WS indicator light has been reported on.
– With service check connector jumped codes 60, 61, 62, 63 are indicated.

Check the No. 38 4WS fuse (60 A) in the under-hood fuse/relay box.

Is the fuse OK?

NO

Replace the fuse and recheck

YES

Measure voltage between the A terminal (WHT) of the 4WS control unit power terminal and body ground.

Is there battery voltage?

NO

Repair open in the WHT wire between the under-hood fuse/relay box and the 4WS control unit.

YES

Measure voltage between the B terminal (BRN) of the 4WS control unit power terminal and body ground.

Is there voltage?

YES

Repair the poor ground (G502) or open in the BRN wire between the 4WS control unit and body ground (G502).

NO

Start the engine and immediately (within approximately 2 seconds after starting the engine) check for voltage between the C terminal (RED) of the 4WS control unit power terminal and body ground.

Is there battery voltage momentarily?

NO

Replace the 4WS control unit.

YES

(To page 17-72)

4WS CONTROL UNIT POWER TERMINAL

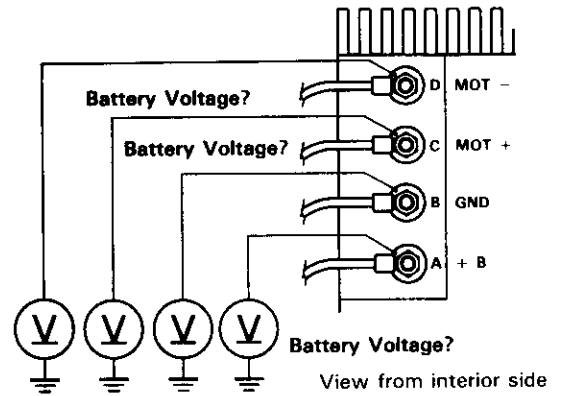

Troubleshooting (4WS)

Diagnostic Trouble Codes (DTCs): 60, 61, 62, 63 (cont'd)

(From page 17-71)

Stop the engine and turn the ignition switch ON.

Measure voltage between the D terminal (BLK) of the 4WS control unit power terminal and body ground immediately after (within approximately 2 seconds) starting the engine.

Is there battery voltage momentarily?

NO

Replace the 4WS control unit

YES

Measure voltage between the C terminal (RED) of the rear actuator motor and body ground immediately after (within approximately 2 seconds) starting the engine.

Is there battery voltage?

NO

Repair open in the RED wire between the 4WS control unit and the rear actuator motor.

YES

Measure voltage between the D terminal (BLK) of the rear actuator motor and body ground immediately after (within approximately 2 seconds) starting the engine.

Is there battery voltage?

NO

Repair open in the BLK wire between the 4WS control unit and the rear actuator motor.

YES

Measure voltage between the No. 33 terminal (YEL) of the rear actuator motor and body ground immediately after (within approximately 2 seconds) starting the engine.

(To page 17-73)

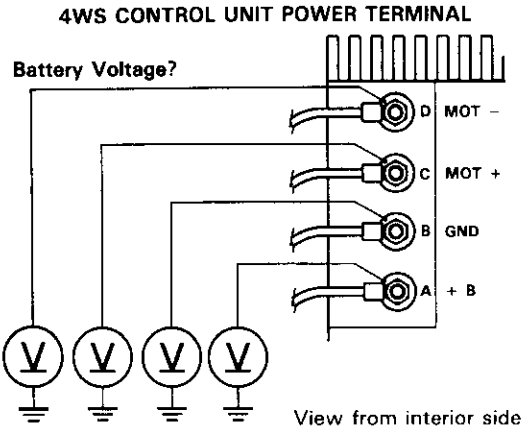

ACTUATOR MOTOR TERMINAL

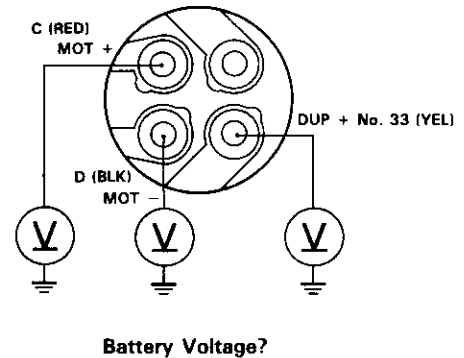



(From page 17-72)

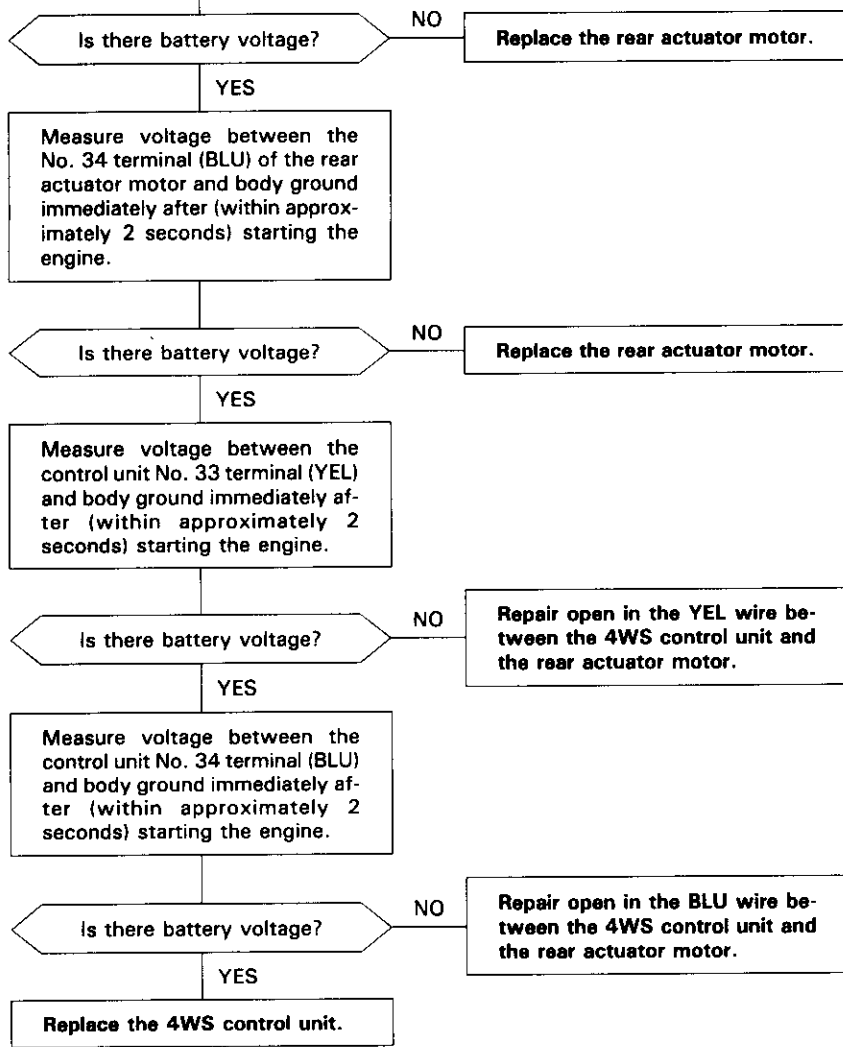

ACTUTOR MOTOR TERMINAL

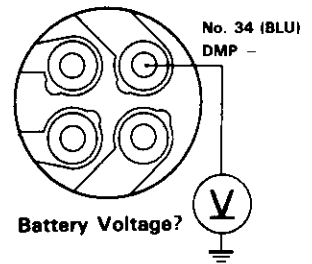

4WS CONTROL UNIT 4P CONNECTOR

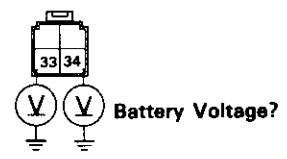

View from terminal side

Maintenance

Pump Belt Adjustment

NOTE: When using a new belt, first adjust the deflection or tension to the values for the new belt, then readjust the deflection or tension to the values for the used belt after running engine for five minutes.

1. Apply a force of 100 N (10 kg, 22 lbs) and measure the deflection between the power steering pump and the crankshaft pulleys.

Deflection:

Used belt: 13.5–16.5 mm (0.53–0.65 in)

New belt: 9.5–11.5 mm (0.37–0.45 in)

NOTE: If there are cracks or any damage evident on the belt, replace it with a new one.

POWER STEERING PULLEY

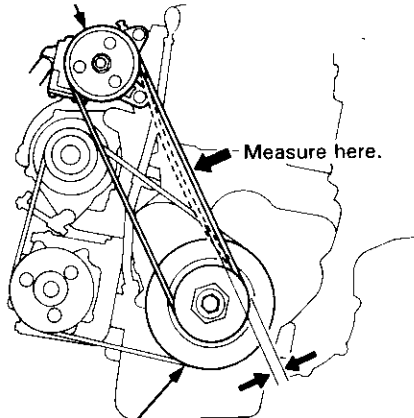

CRANKSHAFT PULLEY

Measure with Belt Tension Gauge:
Attach the belt tension gauge to the belt and measure the tension of the belt.

Tension:

Used belt: 350–500 N (35–70 kg, 77–110 lbs)

New belt: 700–900 N (70–90 kg, 154–198 lbs)

NOTE: If there are cracks or any damage evident on the belt, replace it with a new one.

Follow the manufacturer's instructions for the tension gauge.

POWER STEERING PULLEY

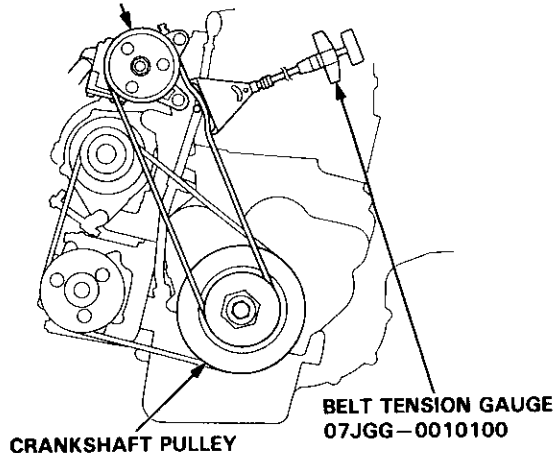

2. Loosen the power steering pump mounting bolt, nuts and adjusting bolt locknut.
3. Turn the adjusting bolt to get the proper belt tension, then retighten the adjusting bolt locknut and mounting bolts.
4. Start the engine and turn the steering wheel from lock-to-lock several times, then stop the engine and recheck the deflection of the belt.

POWER STEERING MOUNTING BOLT

22 N·m (2.2 kg·m, 16 lb-ft)

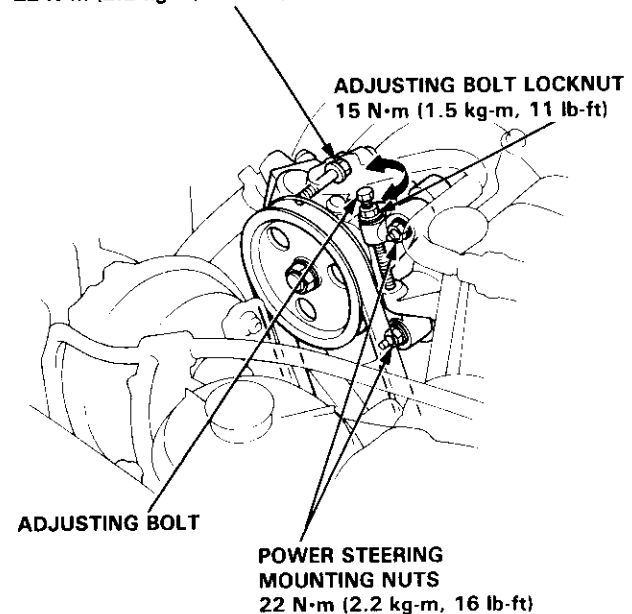



On-Car Checks

Rack Guide Adjustment

CAUTION: When servicing, be careful not to damage the power steering fluid lines with the special tool.

NOTE: Adjust the rack guide at the center of the rack stroke.

2WS:

1. Remove the gearbox shield.
2. Loosen the rack guide screw locknut with the special tool.
3. Tighten, loosen and retighten the rack guide screw two times to 4 N·m (0.4 kg-m, 2.9 lb-ft) then back it off 20^{+5}_0 °.
4. Tighten the locknut to about 25 N·m (2.5 kg-m, 18 lb-ft) while holding the guide screw.
5. Check for tight or loose steering through the complete turning travel.
6. Recheck steering assist (see page 17-79).

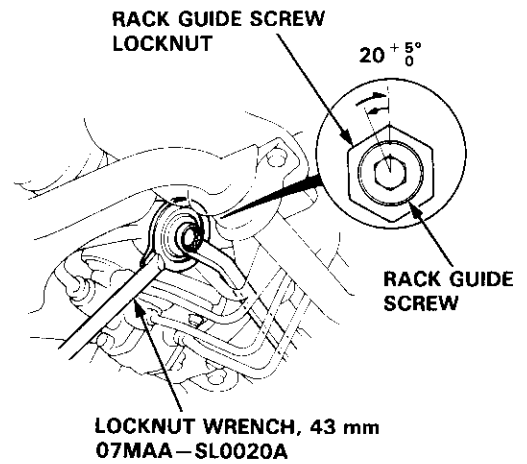

(cont.)

On-Car Checks

Rack Guide Adjustment (cont'd)

4WS:

1. Remove the gearbox shield.
2. Cut wire tie from the cover, then remove the cover from the front sub steering angle sensor.

CAUTION: Cut the wire tie with carefully, so as not to damage the harness.

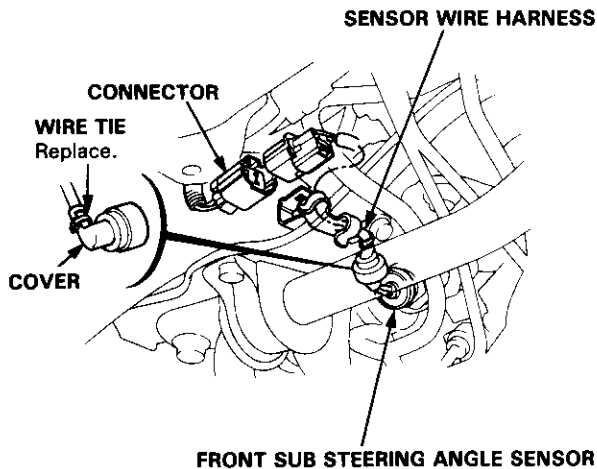

3. Remove the sub steering angle sensor wire harness from the clamp and disconnect the connector.

4. Loosen the rack guide screw locknut with the special tool.
5. Tighten, loosen and retighten the rack guide screw two times to 4 N·m (0.4 kg-m, 2.9 lb-ft) then back it off $20 \begin{smallmatrix} +5^\circ \\ 0 \end{smallmatrix}$.
6. Tighten the locknut to about 25 N·m (2.5 kg-m, 18 lb-ft) while holding the rack guide screw.
7. Check for tight or loose steering through the complete turning travel.
8. Recheck steering assist (see page 17-79).

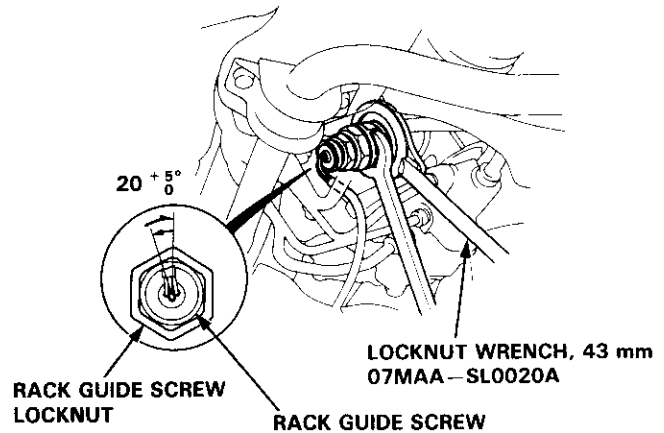

9. Reconnect the connector and secure the sensor wire harness with the clamp and install the cover.

NOTE:

- Be sure the sensor wire harness does not interfere with the stabilizer and other moving parts.
- Be certain that the sensor wire harness is not twisted before connecting it.

10. Set the cover on the front sub steering angle sensor. Secure the cover with the new wire tie.

NOTE: After rack guide adjustment, perform the electrical check on the 4WS system (see page 17-146).



On-Car Checks

Fluid Replacement

Fluid Level Inspection

Check the power steering fluid level with the engine cold and the car parked on level ground. Make sure the fluid level is between the UPPER and LOWER level lines on the reservoir. If the level is near or below the lower level line, check the system for leaks. If the system is not leaking, and fluid level is low, add fluid to the upper level line.

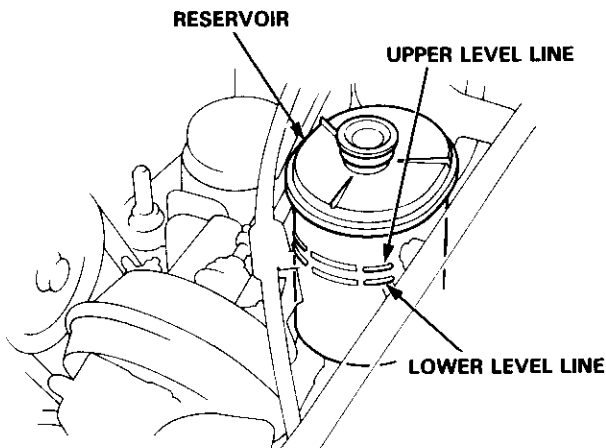

Fluid Replacement

1. Raise the reservoir and disconnect the hose that goes to the oil cooler.
2. Connect a hose of suitable diameter to the disconnected hose that goes to the oil cooler and put the hose end in a suitable container.
3. Start the engine, let it run at idle, and turn the steering wheel from lock-to-lock several times. When fluid stops running out of the hose, shut off the engine. Discard the fluid.

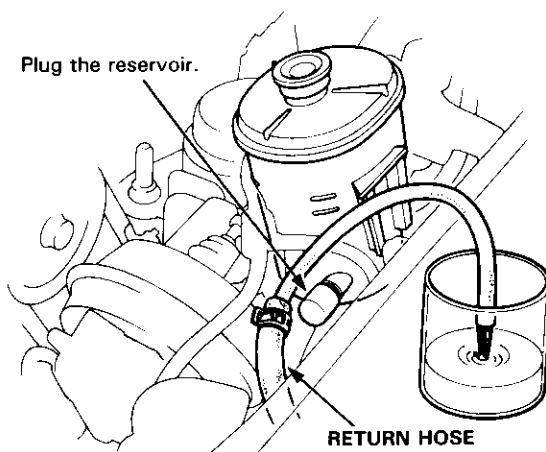

4. Reconnect the return hose to the reservoir.
5. Fill the reservoir to the upper level line.

NOTE: Take care not to spill the fluid on the body and parts. Wipe off the spilled at once.

CAUTION: Use only Honda Power Steering Fluid-V. Using other fluids such as ATF or other manufacturer's power steering fluid will damage the system.

System Capacity:

1.7 liter (1.80 US qt, 1.50 Imp qt) at change

Reservoir Capacity:

0.5 liter (0.53 US qt, 0.44 Imp qt)

6. Start the engine and run it at idle, then turn the steering from lock-to-lock several times to bleed air from the system.
7. Recheck the fluid level and add some if necessary.

CAUTION: Do not fill the reservoir beyond the upper level line.

On-Car Checks

Pump Pressure Check

Check the fluid pressure as follows to determine whether the trouble is in the pump or gearbox.

NOTE: First check the power steering fluid level and pump belt tension.

CAUTION: Disconnect the high pressure hose carefully, so as not to spill the power steering fluid on the frame and other parts.

1. Disconnect the outlet hose from the pump outlet fitting, and install the pump joint adaptor on the pump outlet.
2. Connect the hose joint adaptor to the power steering pressure gauge, then connect the outlet hose to the adaptor.
3. Install the power steering pressure gauge to the pump joint adaptor as shown.

4. Open the shut-off valve fully.
5. Open the pressure control valve fully.
6. Start the engine and let it idle.
7. Turn the steering wheel from lock-to-lock several times to warm the fluid to operating temperature.
8. Close the shut-off valve, then close the pressure control valve gradually until the pressure gauge needle is stable. Read the pressure.
9. Immediately open the shut-off valve fully.

CAUTION: Do not keep the shut-off valve closed more than 5 seconds or the pump could be damaged by over-heating.

If the pump is in good condition, the gauge should read at least 7,000–8,000 kPa (70–80 kg/cm², 995–1,138 psi). A low reading means pump output is too low for full assist. Repair or replace the pump.

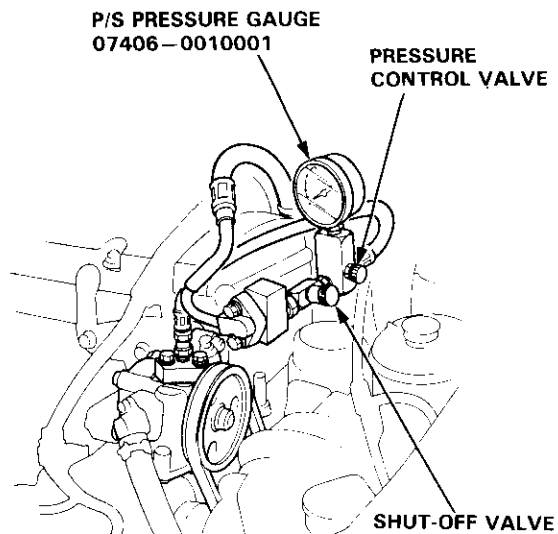
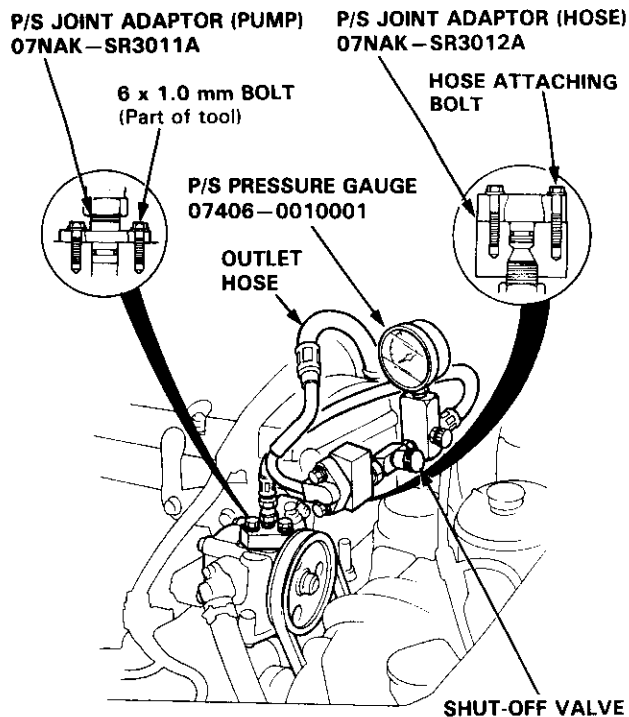



Steering Wheel Rotational Play

1. Place the front wheels in the straight ahead position and measure the distance the steering wheel can be turned without moving the front wheels.
2. If the play exceeds the service limit, check all steering components.

0–10 mm (0–0.4 in)

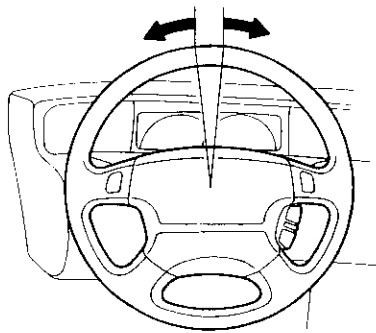

Power Assist Check with Car Parked

1. Check the power steering fluid level and pump belt tension.
2. Start the engine, allow it to idle, and turn steering wheel from lock-to-lock several times to warm up the fluid.
3. Attach a spring scale to the steering wheel. With the engine idling and the car on a clean, dry floor, pull the scale as shown and read it as soon as the tires begin to turn.

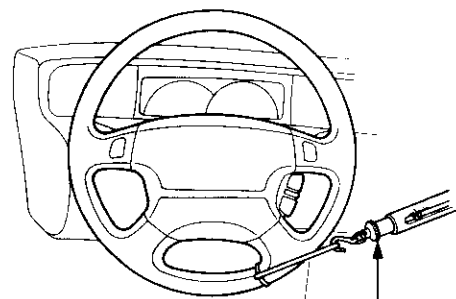

SPRING SCALE

4. The scale should read no more than 30 N (3.0 kg, 6.6 lbs).
If it reads more or less, go on step 5.
5. Stop the engine. Disconnect the hose from the power steering speed sensor and plug the hose and the sensor fitting as shown.

POWER STEERING SPEED SENSOR

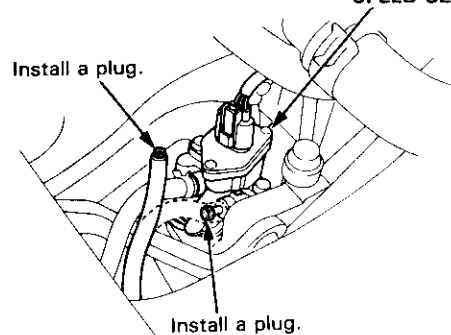

6. Start the engine and let it idle.
 - If the reading is now 30 N (3.0 kg, 6.6 lbs) or less, replace the power steering speed sensor, see page 17-80.
 - If the reading is still more than 30 N (3.0 kg, 6.6 lbs), check the gearbox and pump.

On-Car Checks

Assist Check at Road Speed

1. Check the power steering fluid level (see page 17-77) and pump belt tension (see page 17-74).
2. Start the engine, let it warm up to normal operating temperature (the cooling fan comes on), and turn the steering wheel lock-to-lock a few times to warm up the fluid.
3. Stop the engine. To simulate speeds above 50 mph (80 km/h), disconnect the hoses from the power steering speed sensor and connect them to the bypass tube joint. Plug the end of the bypass tube joint.

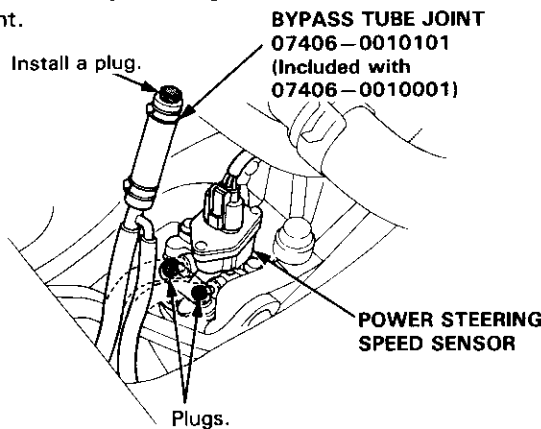

4. Attach the spring scale to the steering wheel. With the engine idling and the car on a clean, dry floor, pull the scale as shown and read it as soon as the tires begin to turn.

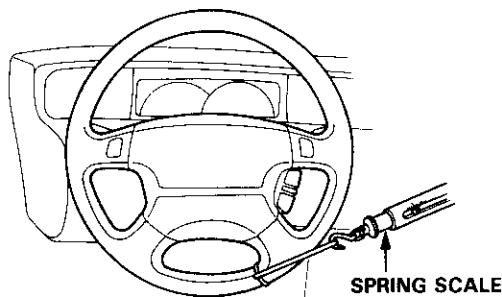

- If the scale reads a normal 50 N (5.0 kg, 11 lbs), or more the assist problem at high speeds is being caused by reduced power steering speed sensor output. Replace the power steering speed sensor.
- If the scale reads less than 50 N (5.0 kg, 11 lbs), the power steering speed sensor is OK and the problem is in the sensor feed line, the pump, or the valve body unit. See if the feed line is pinched or bent then check pump.
- See General Troubleshooting (see page 17-25).

Power Steering Speed Sensor Replacement

1. Remove the rear mounting bracket stay.
2. Disconnect the sensor wire connector from the power steering speed sensor.
3. Remove the sensor mounting bolt and pull the power steering speed sensor from the differential housing.
4. Disconnect the sensor hoses and plug the fittings.

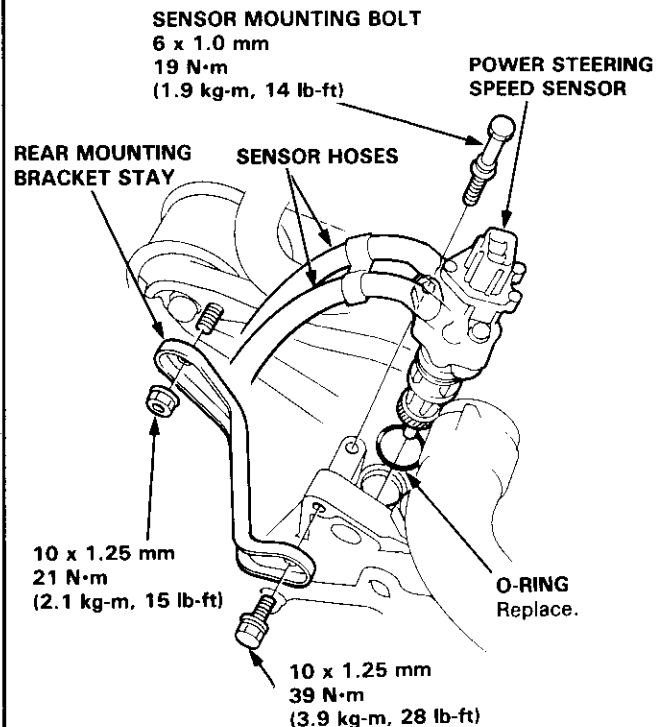

5. After installing a new power steering speed sensor, turn the steering wheel lock-to-lock with the engine idling to bleed air from the system.
6. Check the reservoir and add fluid if necessary (see page 17-77).



Steering Wheel

Removal

With SRS:

⚠ WARNING Store a removed driver's airbag assembly with the pad surface up, if the airbag is improperly stored face down, accidental deployment could propel the unit with enough force to cause serious injury.

CAUTION:

- Before removing the steering wheel, align the front wheels straight ahead.
- Do not install used SRS parts from another car. When repairing, use only new SRS parts.
- Carefully inspect the airbag assembly before installing. Do not install an airbag assembly that shows signs of being dropped or improperly handled, such as dents, cracks or deformation.
- Always keep the short connector(s) on the airbag(s) when the harness is disconnected.
- Do not disassemble or tamper with the airbag assembly.

NOTE:

The radio may have a coded theft protection circuit. Be sure to get the customer's code number before

- Disconnecting the battery.
- Removing the No. 43 (10 A) fuse (in the underhood fuse/relay box).
- Removing the radio.

After service, reconnect power to the radio and turn it on. When the word "CODE" is displayed, enter the customer's 5-digit code to restore radio operation.

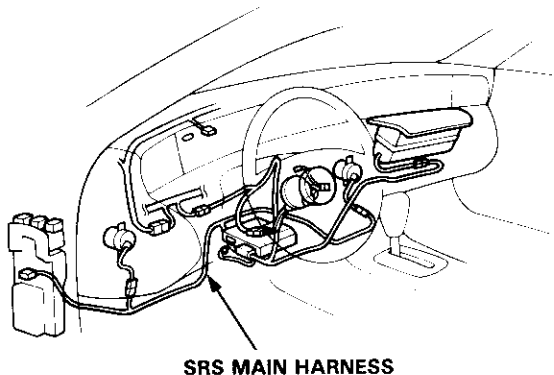

1. Disconnect the negative and positive cable from the battery.
2. Remove the access panel from the steering wheel lower cover, then remove the short connector (RED).
3. Disconnect the connector between the airbag and cable reel.
4. Connect the short connector (RED) to the airbag side of the connector.

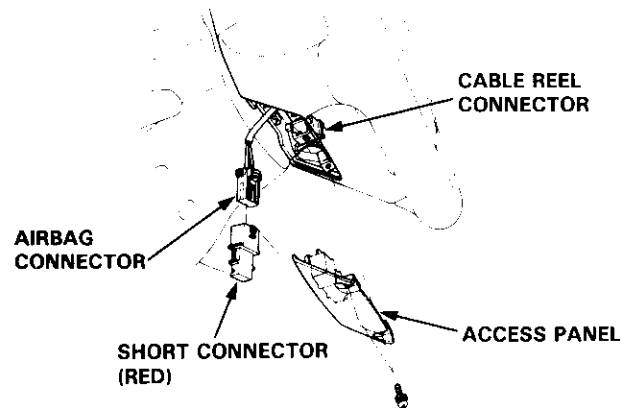

5. Remove the covers.
6. Remove the two TORX® T30 bit bolts, then remove the driver's airbag assembly.

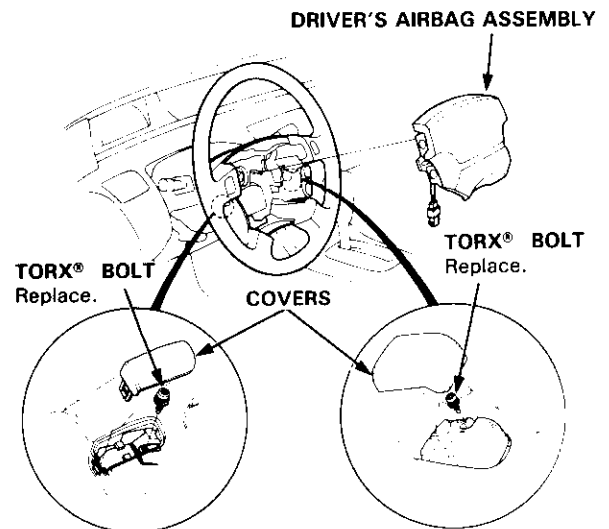

(cont'd)

Steering Wheel

Removal (cont'd)

7. Disconnect the connectors from the horn and cruise control set/resume switches connector.

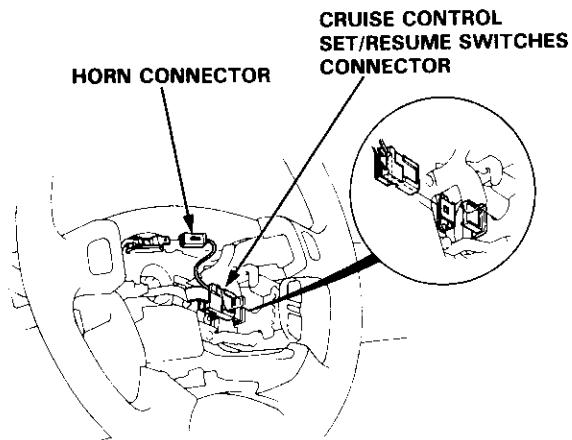

- Remove the steering wheel nut.
- Remove the steering wheel by rocking it slightly from side-to-side as you pull steadily with both hands.

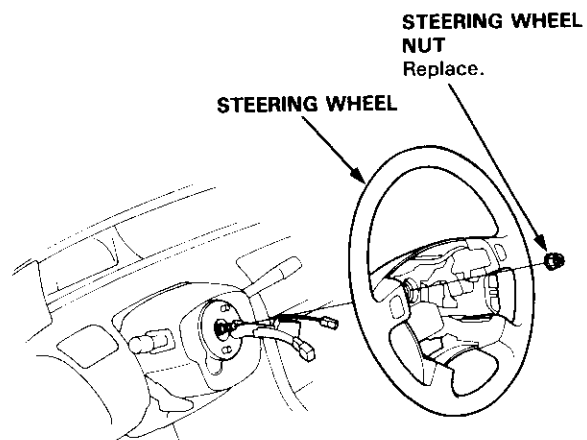

Without SRS:

- Remove the emblem and steering wheel nut.

NOTE: Be careful not to damage the emblem and steering wheel.

- Remove the steering wheel by rocking it slightly from side-to-side as you pull steadily with both hands.

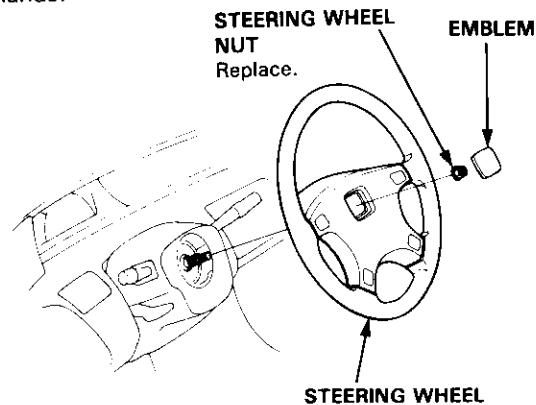



Disassembly/Reassembly

▲ WARNING Store a removed driver's airbag assembly with the pad surface up. If the airbag is improperly stored face down, accidental deployment could propel the unit with enough force to cause serious injury.

NOTE: If an intact driver's airbag assembly has been removed from a scrapped car or has been found defective or damaged during transit, storage or service, it should be deployed (see section 23).

CAUTION:

- Carefully inspect the driver's airbag assembly before installing. Do not install the driver's airbag assembly that shows signs of being dropped or improperly handled, such as dents, cracks or deformation.
- Always keep the short connector(s) on the airbag(s) when the harness is disconnected.
- Do not disassemble or temper, with the driver's airbag assembly.

<With SRS:>

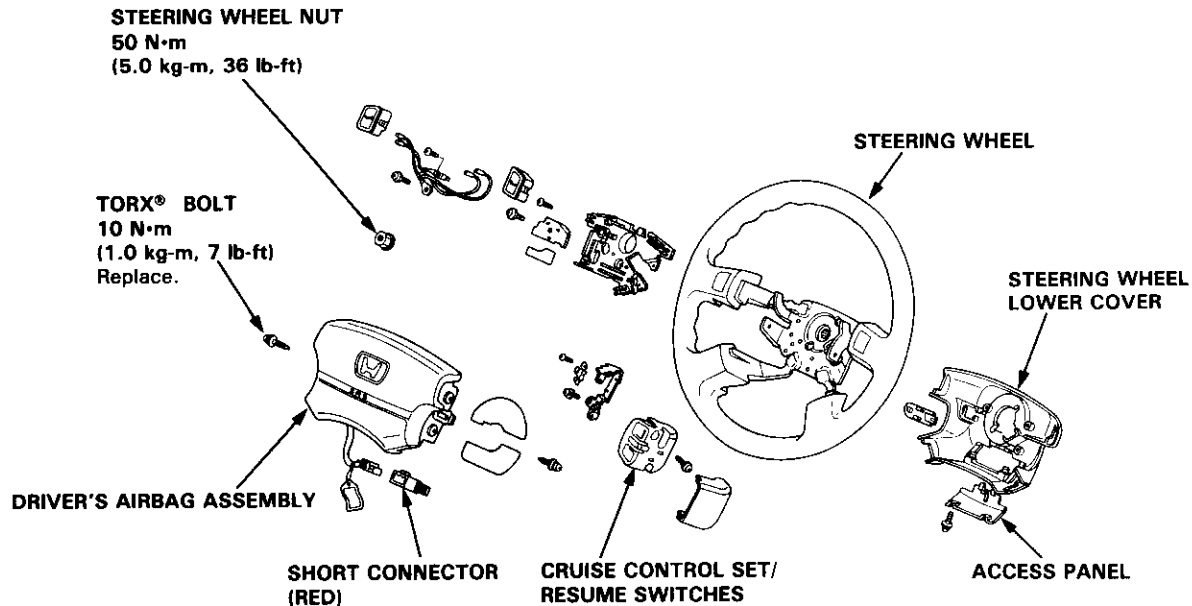

<Without SRS:>

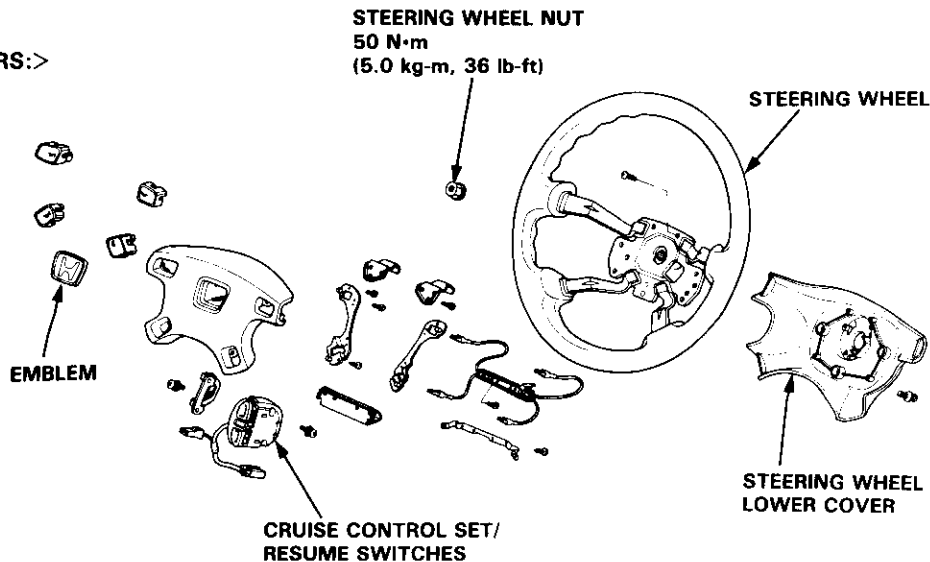

Steering Wheel

Installation

2WS/With SRS:

CAUTION:

- Before installing the steering wheel, align the front wheels straight ahead.
- Be sure to install the harness wires so that they are not pinched or interfering with other car parts.
- Do not replace the original steering wheel with any other design, since it will make it impossible to properly install the airbag. (Only use genuine HONDA replacement parts)
- After reassembly, confirm that the wheels are still straight ahead and that steering wheel spoke angle is correct. If minor spoke angle adjustment is necessary, do so only by adjustment of the tie rods, not by removing and repositioning the steering wheel.

▲WARNING Confirm that the driver's airbag assembly is securely attached to the steering wheel; otherwise, severe personal injury could result during airbag deployment.

1. Before installing the steering wheel, center the cable reel.
Do this by first rotating the cable reel clockwise until it stops.
Then rotate it counterclockwise (approximately two turns) until:
 - The yellow gear tooth lines up with the alignment mark on the cover.
 - The arrow mark on the cable reel label points straight up.

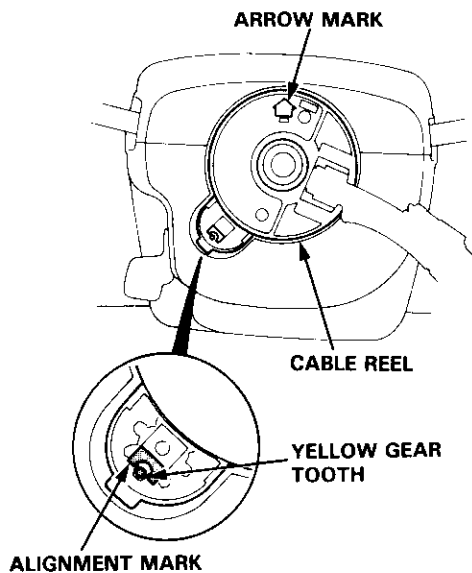

2. Install the steering wheel and tighten the steering wheel nut.

NOTE: Be sure the steering wheel shaft engages the pins of the cable reel.

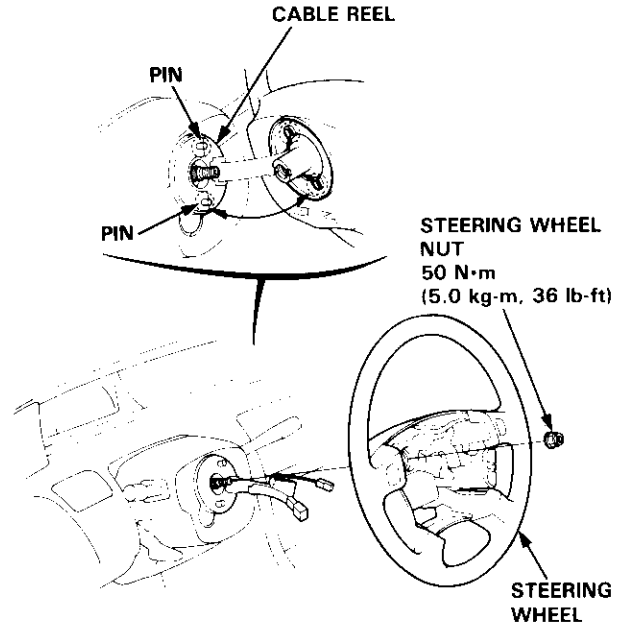

3. Insert the cruise control set/resume switches connector to the steering wheel clips.
4. Connect the horn connector.

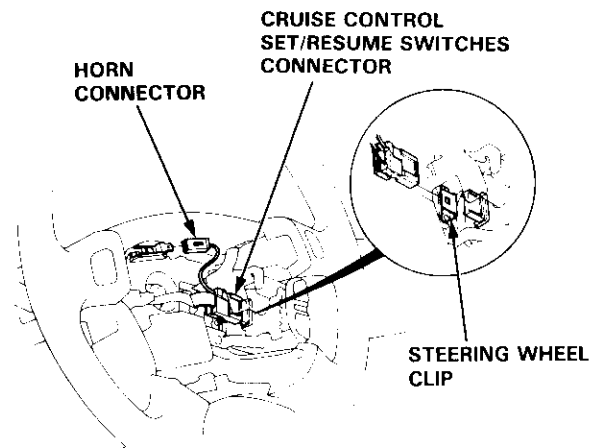



5. Install the driver's airbag assembly with new TORX® bolts.

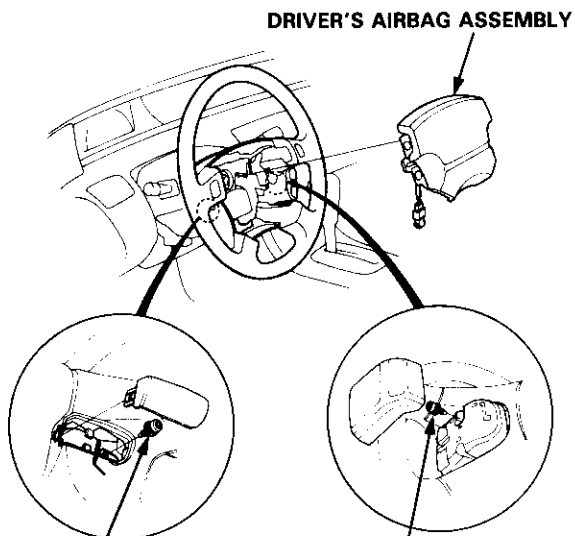

TORX® BOLT
10 N·m (1.0 kg-m, 7 lb-ft)

TORX® BOLT
10 N·m (1.0 kg-m, 7 lb-ft)

6. Disconnect the short connector (RED) from the airbag connector.
7. Connect the airbag connector and cable reel connector.
8. Attach the short connector (RED) to the access panel, and install the access panel on the steering lower cover.

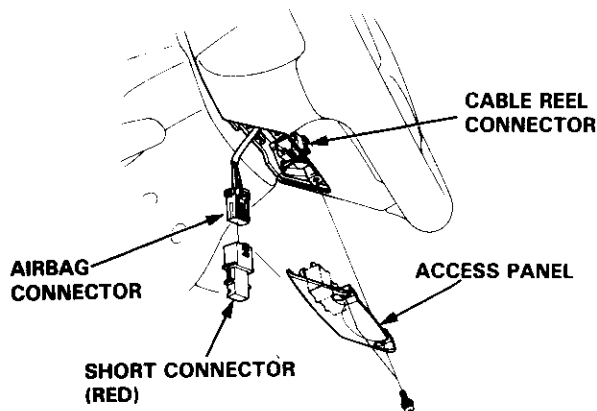

9. Connect the battery positive terminal and then connect the negative terminal.

10. After installing the driver's airbag assembly, confirm proper system operation:

- Turn the ignition to II position; the instrument panel SRS indicator light should come on for about six seconds and then go off.
- Confirm operation of horn buttons.
- Confirm operation of cruise control set/resume switches.
- Turn the steering wheel counterclockwise and make sure the yellow gear tooth still lines up with the alignment mark.

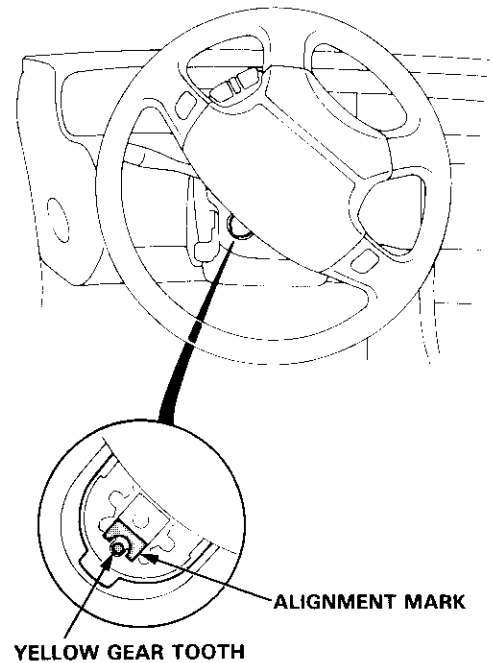

Steering Wheel

Installation (cont'd)

2WS/Without SRS:

1. Install the steering wheel and tighten the steering wheel nut.

NOTE: Align the slots on the steering wheel and tabs on the turn signal cancelling sleeve.

2. Install the emblem.

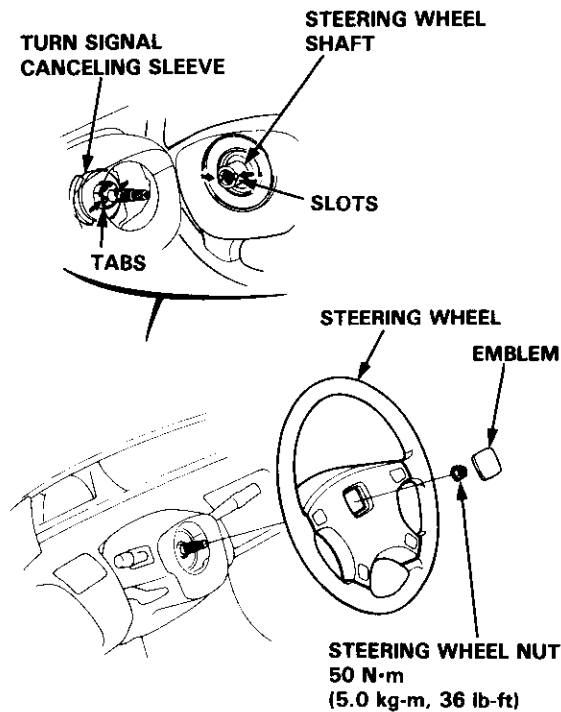

4WS/With SRS:

CAUTION:

- The front main steering angle sensor with the neutral lock mechanism is mounted on the column shaft of the car. When the steering wheel is removed, the rotation part of the sensor is locked at the electrically neutral position, and it is unlocked when the steering wheel is inserted to the specified installation position.
- If the spoke angle is not at the designated angle while driving straight, check the front and rear wheels for proper alignment before adjusting the spoke angle. Perform the electronic neutral check of the 4WS system to be sure that the rear wheels are at the correct steering angle while driving (see page 17-146).
- Before installing the steering wheel, align the front wheels straight ahead.
- Be sure to install the harness wires so that they are not pinched or interfering with other car parts.
- Do not replace the original steering wheel with any other design, since it will make it impossible to properly install the airbag. (Only use genuine HONDA replacement parts)

▲ WARNING Confirm that the airbag assembly is securely attached to the steering wheel; otherwise, severe personal injury could result during later airbag deployment.

1. Before installing the steering wheel, center the cable reel.
Do this by first rotating the cable reel clockwise until it stops.
Then rotate it counterclockwise (approximately two turns) until:
 - The yellow gear tooth lines up with the alignment mark on the cover.
 - The arrow mark on the cable reel label points straight up.

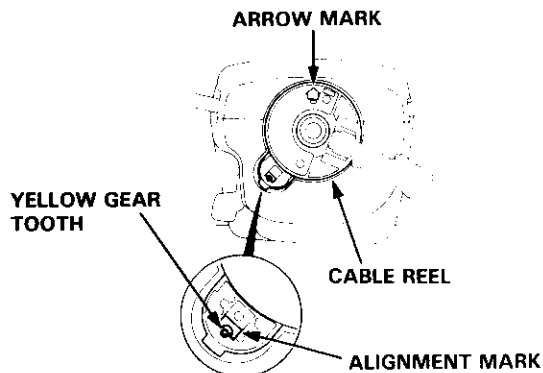



- Temporarily install the steering wheel aligning it with the column shaft serration.
- Turn the steering wheel fully to the right and left and set the steering wheel in the center of the range where the front wheels move (i.e. center the steering rack).

NOTE:

- Be sure that the front wheels are in the straight ahead driving position.
- Be sure the steering wheel shaft engages the pins of the cable reel.

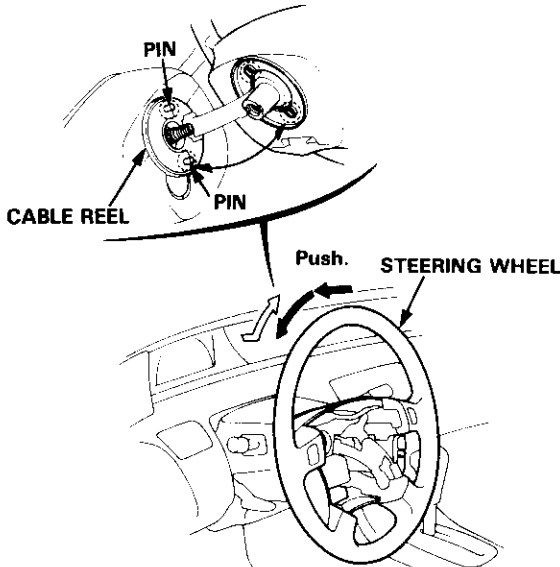

- Remove the steering wheel.
- Check whether the yellow paint mark of the front main steering angle sensor rotor is facing down (i.e. in neutral lock position where the rotor does not turn).

NOTE: If the paint mark is not facing down, adjust as follows.

- Temporarily install the steering wheel with the spokes at a horizontal angle.
- Turn the steering wheel until the mark is facing down.
- Return the steering wheel spokes to the horizontal angle set in the step 1, being careful not to push in the steering wheel. Remove the steering wheel.

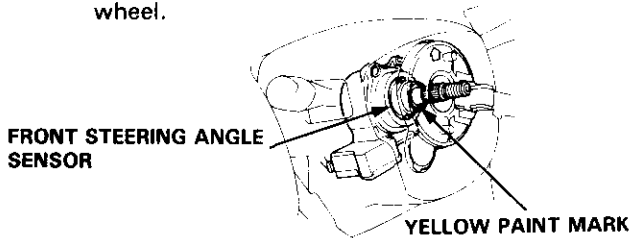

- Reinstall the steering wheel in the straight ahead driving position, being careful not to make it off to either side from the position set in step 3.

NOTE:

- Align the hole in the steering wheel with the pin of the cable reel.
- Align the steering wheel with the serrations which makes the spoke angle closest to horizontal.

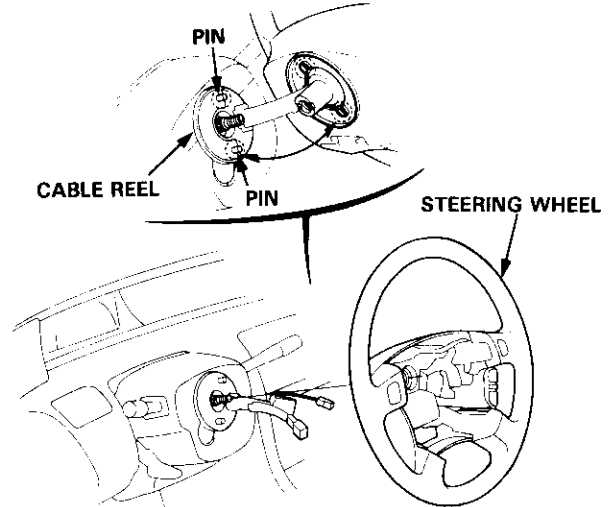

- If the spoke angle is not horizontal, adjust the steering wheel slightly right or left, without pushing in the steering wheel too deep.

STEERING WHEEL NUT
50 N·m
(5.0 kg-m, 36 lb-ft)

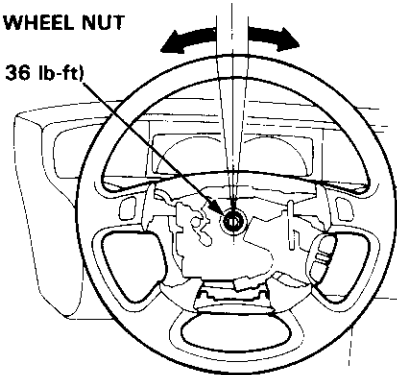

With the spoke angle set at the horizontal, then push the steering wheel in fully. Tighten the steering wheel nut while pushing the steering wheel.

NOTE: Do not turn the steering wheel when pushing the steering wheel.

- Check the four front and rear wheels for alignment and perform the electronic neutral check on the 4WS system (see page 17-146).

(cont.)

Steering Wheel

Installation (cont'd)

9. Insert the cruise control set/resume switches connector to the steering wheel clips. Connect the horn connector.

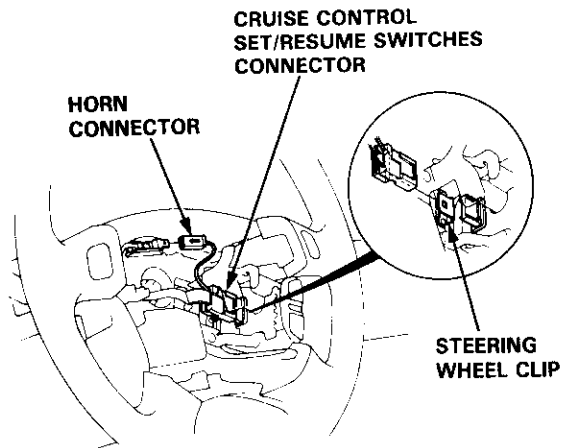

10. Install the driver's airbag assembly with new TORX® bolts.

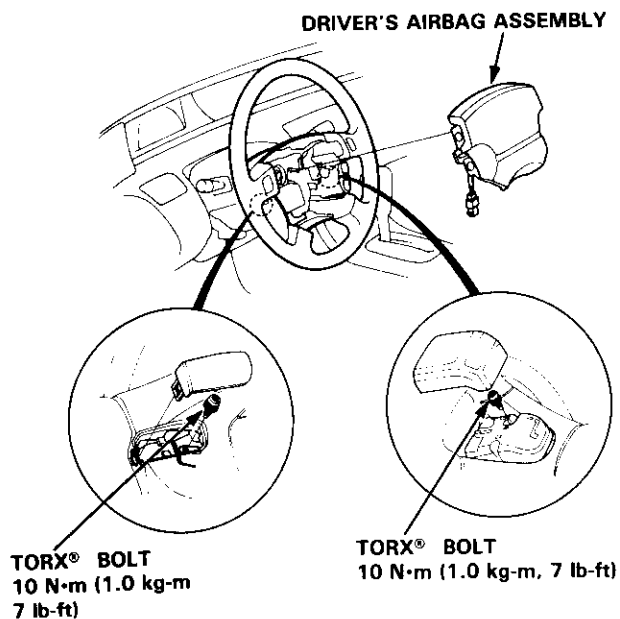

11. Disconnect the short connector (RED) from the airbag connector.
12. Connect the airbag connector and cable reel connector.
13. Attach the short connector (RED) on the access panel, and install the access panel on the steering lower cover.

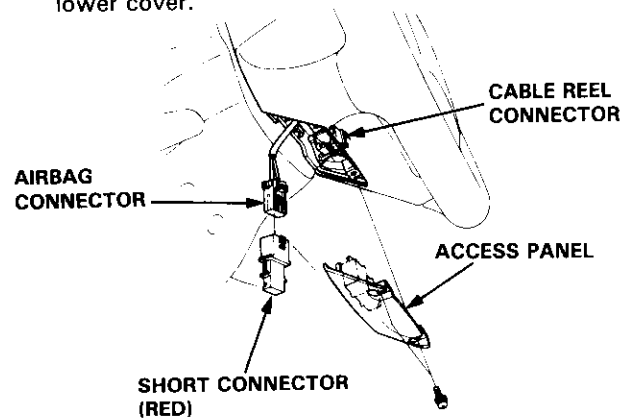

14. Connect the battery positive terminal and then connect the negative terminal.
15. After installing the driver's airbag assembly, confirm proper system operation:
- Turn the ignition to II position; the instrument panel SRS indicator light should come on for about six seconds and then go off.
 - Confirm operation of horn buttons.
 - Confirm operation of cruise control set/resume switches.
 - Turn the steering wheel counterclockwise and make sure the yellow gear tooth still lines up with the alignment mark.

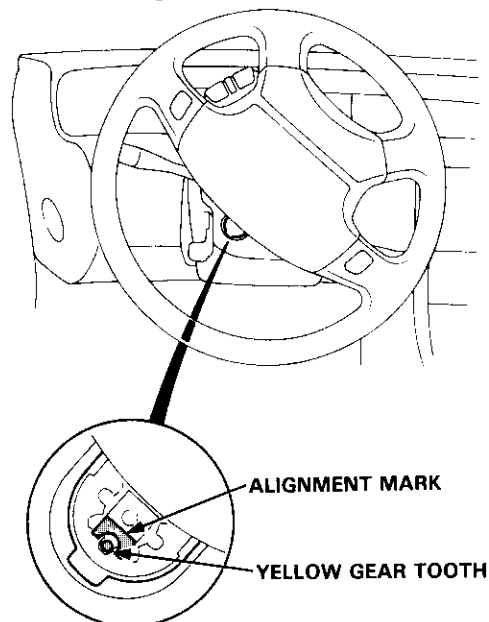

Steering Column



Removal

With 4WS:

CAUTION: The front main steering angle sensor with the neutral lock mechanism is mounted on the column shaft of the car. When the steering wheel is removed, the rotation part of the sensor is locked at the electrically neutral position, and it is unlocked when the steering wheel is inserted to the specified installation position.

With SRS:

CAUTION:

- All SRS electrical wiring harnesses are covered with yellow outer insulation.
- Before disconnecting the SRS wire harness install the short connector(s) on the airbag(s) (see page 23-290).
- Replace the entire affected SRS harness assembly if has an open circuit or damaged wiring.

NOTE:

The radio may have a coded theft protection circuit. Be sure to get the customer's code number before

- Disconnecting the battery.
- Removing the No. 43 (10 A) fuse (in the underhood fuse/relay box).
- Removing the radio.

After service, reconnect power to the radio and turn it on. When the word "CODE" is displayed, enter the customer's 5-digit code to restore radio operation.

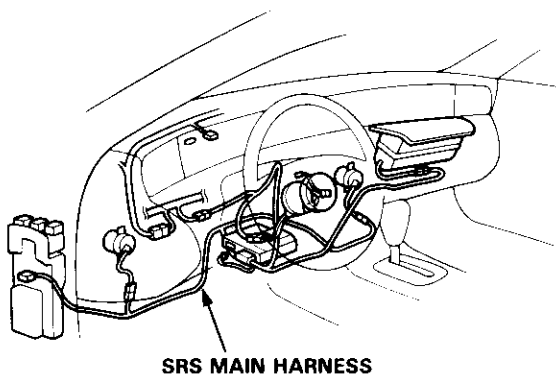

1. Remove the driver's airbag assembly and steering wheel (see page 17-81).
2. Remove the steering joint bolt and toothed lock washer (from the engine compartment).

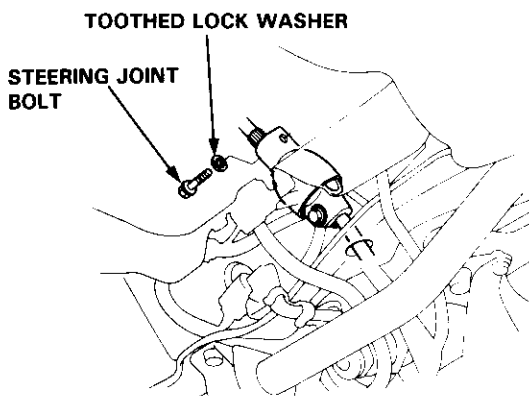

3. Remove the dashboard lower cover and driver's knee bolster.

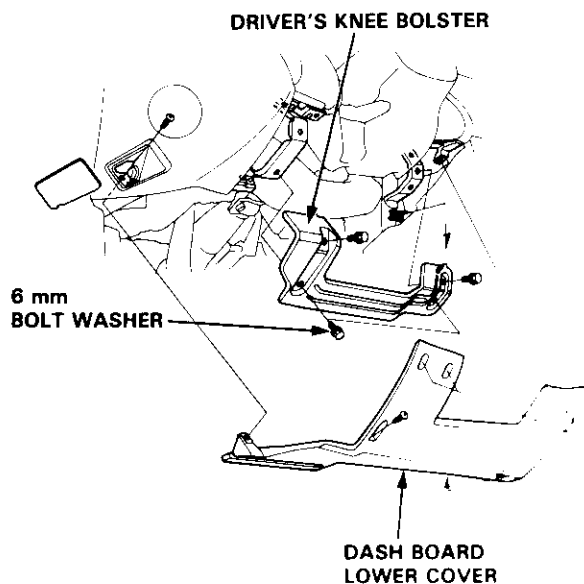

(cont'd)

Steering Column

Removal (cont'd)

4. Remove the upper and lower column covers.

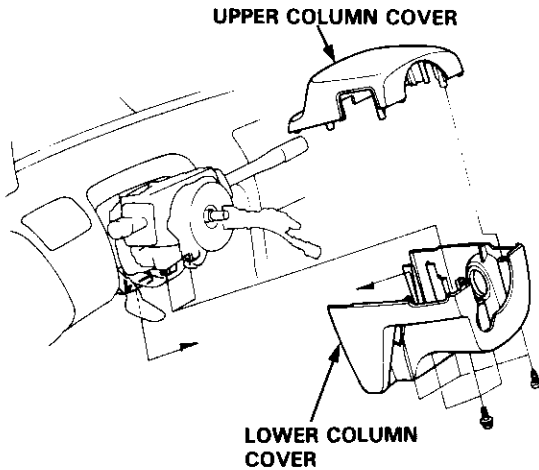

5. Remove the cable reel harness from the underside of the column bracket by removing the clip (SRS only).

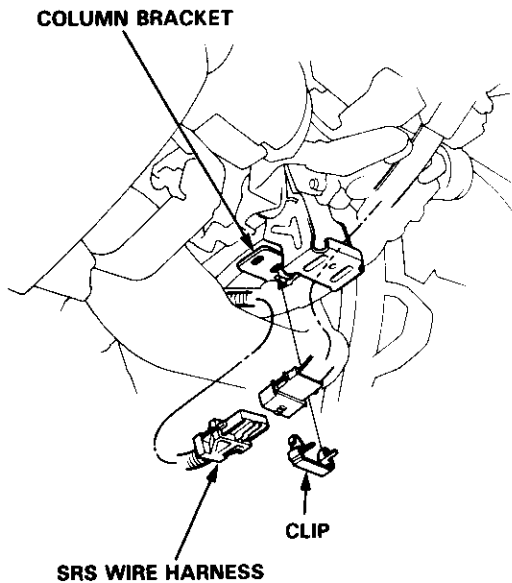

6. Remove the cable reel assembly (SRS only).

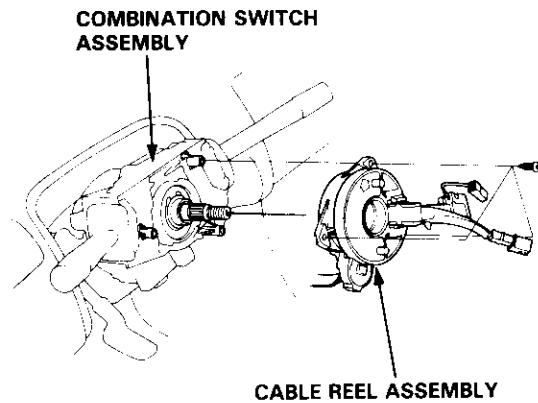

7. Remove the turn signal canceling sleeve, combination switch assembly and front main steering angle sensor (4WS only) by removing the circlip.

NOTE: After removing the combination switch assembly, place it on the floor gently so that it does not hinder you in service. Do not disconnect the cables from the combination switch assembly.

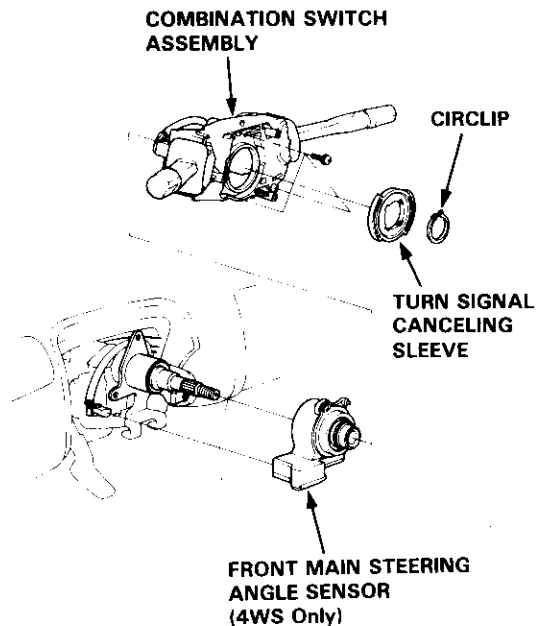



8. Remove the air duct.

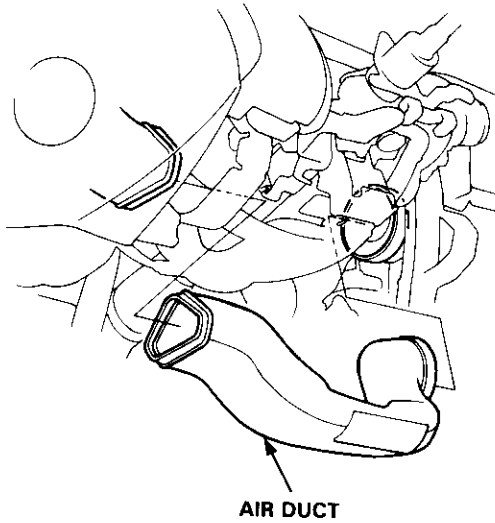

9. Remove the steering joint cover.

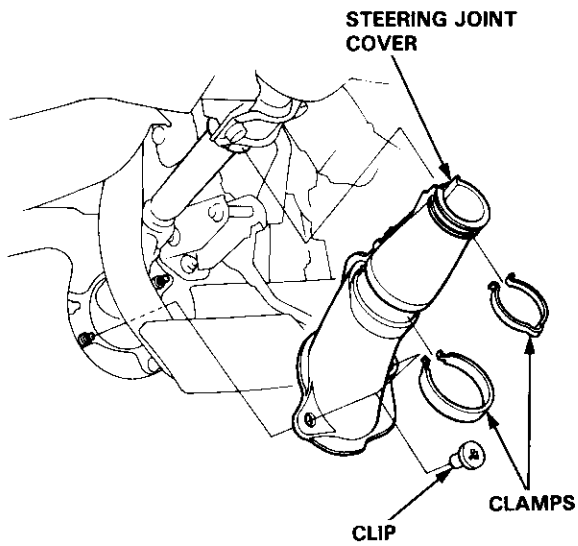

10. Disconnect the ignition switch wire connector.

11. Remove the steering column assembly by removing the attaching nuts, bolts and column holder.

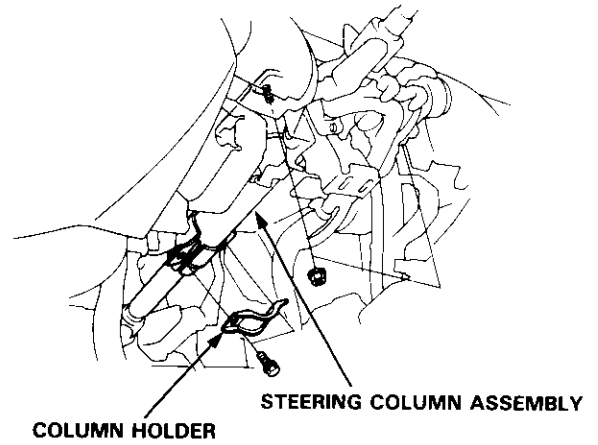

Steering Column

Inspection

NOTE: Check the tilt mechanism, steering joint bearings and steering shaft for proper movement and damage. Replace as an assembly if damaged or faulty.

CAUTION: Do not apply an impact load to the column shaft in the axial direction.

Front Main Steering Angle Sensor (4WS):

Check whether the yellow paint mark of the front main steering angle sensor rotor is facing down (i.e. in neutral lock position where the rotor does not turn). This indicates that the front main steering angle sensor is electronically in neutral.

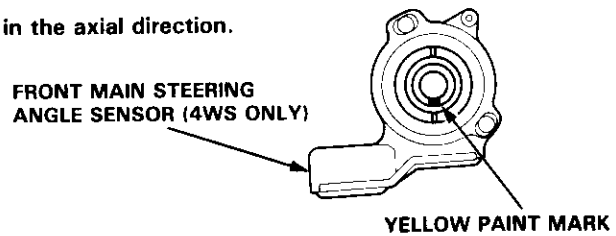

CAUTION: If the front main steering angle sensor is unlocked once, turn it to the locking position and lock securely.

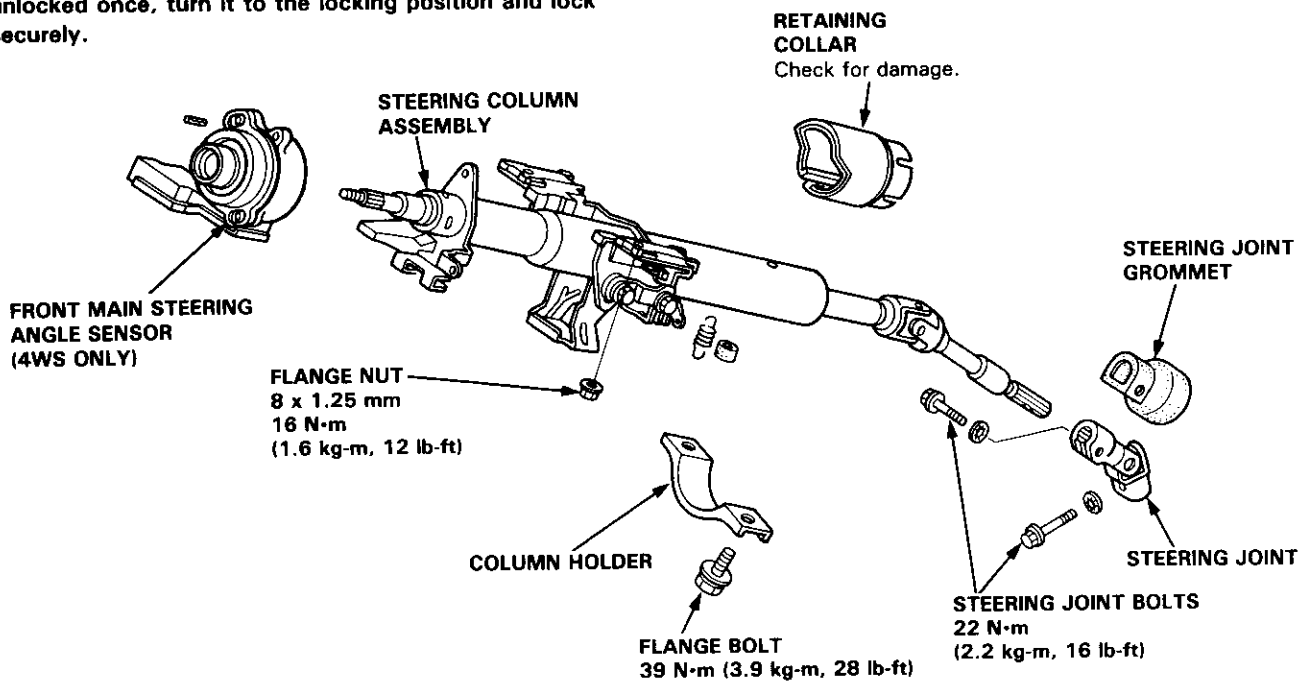

- Check the tilt mechanism for proper movement and damage.

- Attach a spring scale to the knob of the tilt lever. Measure the preload required to move the lever.

Preload: 70–90 N (7–9 kg, 15–20 lbs)

- If the preload measured is not within the specification, remove the 6 mm bolt and stopper. Then adjust the preload by tightening or loosening the tilt lockbolt at the lever pulled up.
- Reinstall the stopper and 6 mm bolt, then recheck the preload again.

CAUTION: Do not loosen the tilt lever when setting the stopper and when tightening the bolt.

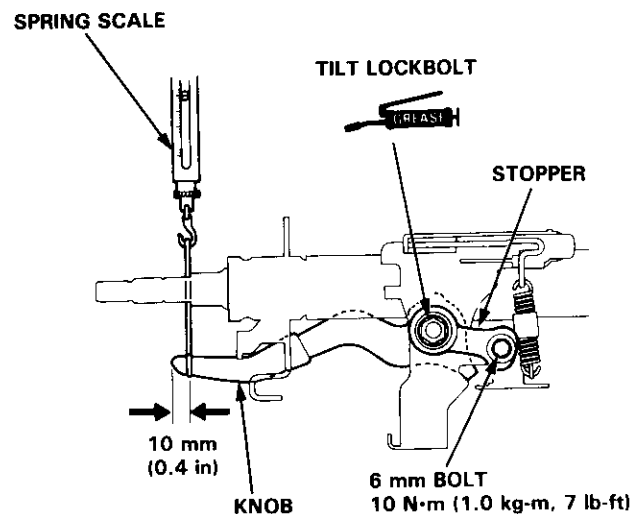



Installation

NOTE:

- Be sure the pinion shaft and the steering shaft are aligned; the joint should slip on freely. If not, reposition the steering rack to correct the misalignment.
 - Coat the interior of the steering joint grommet with grease.
1. Guide the steering shaft through the engine compartment bulkhead. Align the bolt hole in the steering joint with the slot in the steering shaft, and insert the shaft into the steering joint.

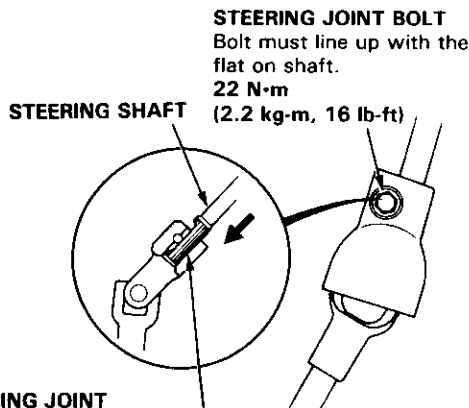

STEERING JOINT

Slip the upper end of the steering joint onto the steering shaft (line up the bolt hole with the groove around the shaft) and install the steering joint bolt.

2. Install the steering column assembly with the nuts, bolts and column holder.
3. Connect the ignition switch connector.

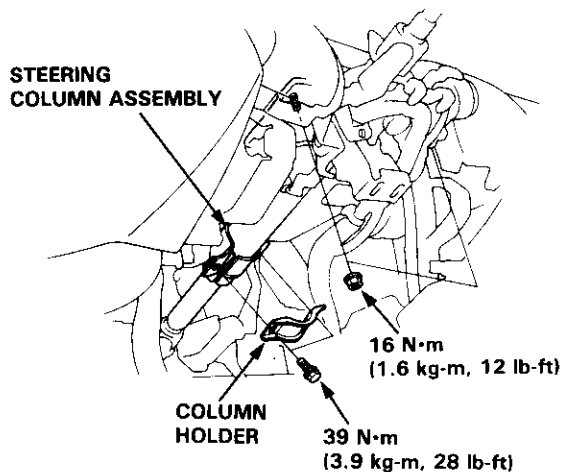

4. Install the steering joint cover with the clamps and clip.

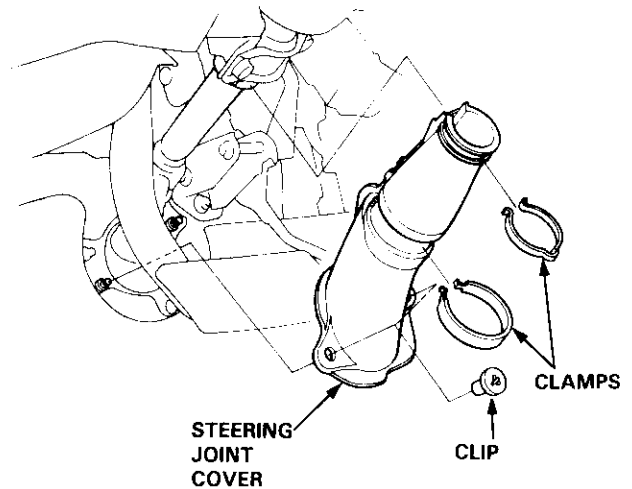

5. Install the front main steering angle sensor (4WS only), combination switch assembly and turn signal canceling sleeve with a circlip.

NOTE:

- Be sure the wires are not caught or pinched by any parts when connecting the combination switch and the cable reel.
- Align the slots in the turn signal canceling sleeve with the tabs on the front main steering angle sensor.

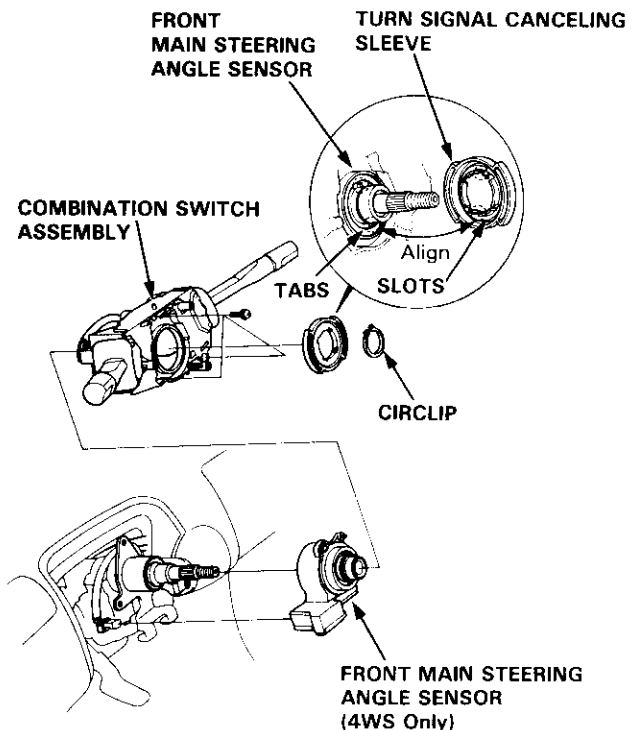

(cont'd)

Steering Column

Installation (cont'd)

6. Install the cable reel assembly (SRS only).

NOTE: Align the slot in the canceling sleeve with the projection on the cable reel (2WS only).

2WS:

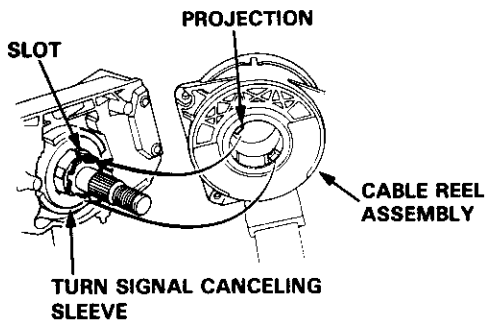

4WS:

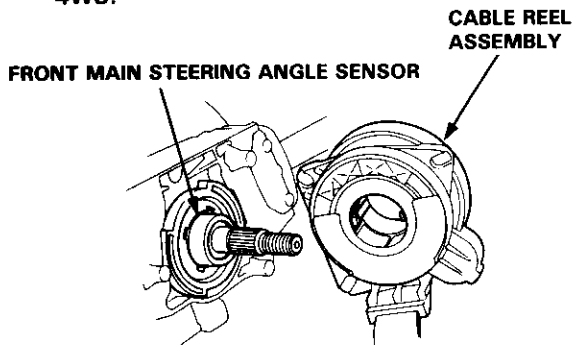

7. Connect the cable reel harness and SRS wire harness, then attach the cable reel harness on the underside of the column bracket with the clip.

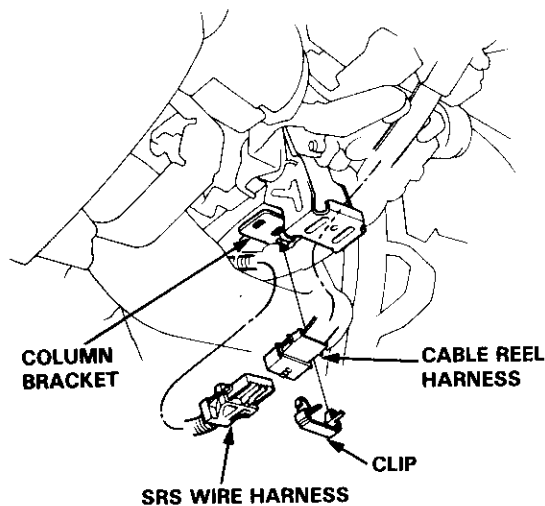

8. Install the upper and lower column covers.

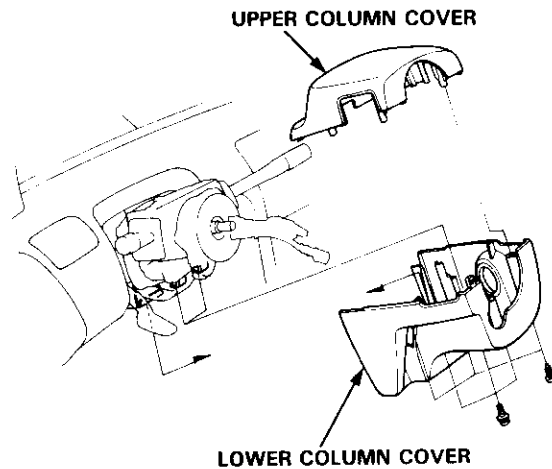

9. Install the air duct.





10. Install the driver's knee bolster and dashboard lower cover.

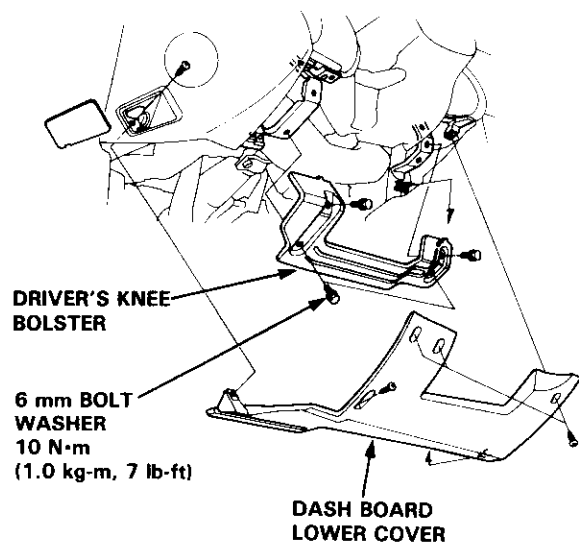

11. Install the steering wheel and driver's airbag assembly (see page 17-84 or 86).

Steering Pump

Replacement

NOTE: Before disconnecting the hoses from the pump, place a suitable container under the car.

1. Drain the fluid from the system (see page 17-77).
2. Remove the belt by loosening the power steering mounting bolt, nut and adjusting bolt.
3. Disconnect the inlet and outlet hoses from the pump and plug them.

NOTE: Take care not to spill the fluid on the body and parts. Wipe off the spilled at once.

4. Remove the power steering mounting bolt and nut, then remove the pump.

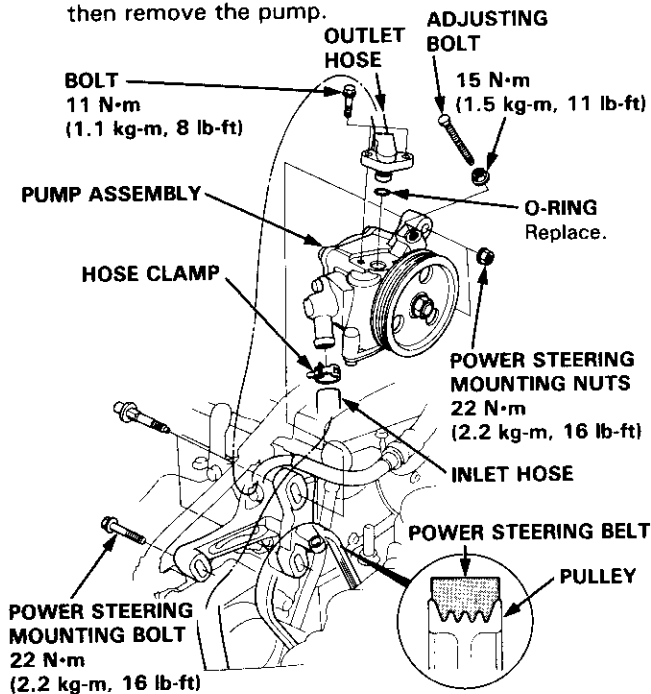

NOTE: Do not turn the steering wheel while the pump removed.

5. Loosely install a new pump on the bracket.
6. Connect the inlet and outlet hoses to the pump.
7. Install and adjust the belt (see page 17-74).

CAUTION:

- Make sure that the power steering belt is securely on the groove of the pulleys.
- Do not get power steering fluid or grease in the power steering belt or pulley faces. Clean off any fluid or grease before installation.

8. Fill the reservoir with new fluid to the UPPER level line on the reservoir (see page 17-77).

Pulley Replacement

Hold the steering pump in a vise with soft jaws, and hold the pulley with the special tool, and remove the pulley nut and pulley.

NOTE: Pulley nut has left-hand threads.

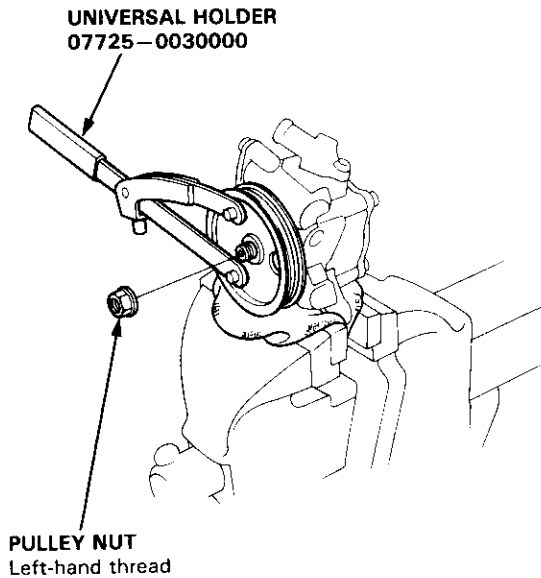

Reinstall the pulley in the reverse order of removal.

NOTE: Install the pulley as shown.

PULLEY NUT
65 N·m (6.5 kg-m, 47 lb-ft)

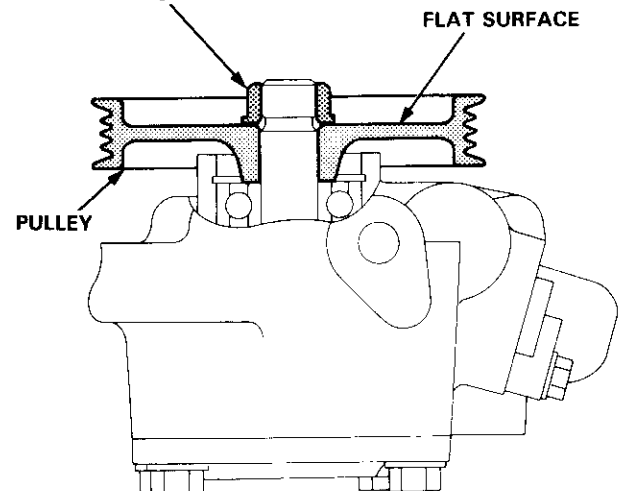

Check that the pump turns smoothly by turning the pulley.



Flow Control Valve Inspection and Replacement

1. Remove the control valve cap by removing the two flange bolts.
2. Remove the flow control valve, spring and O-rings.

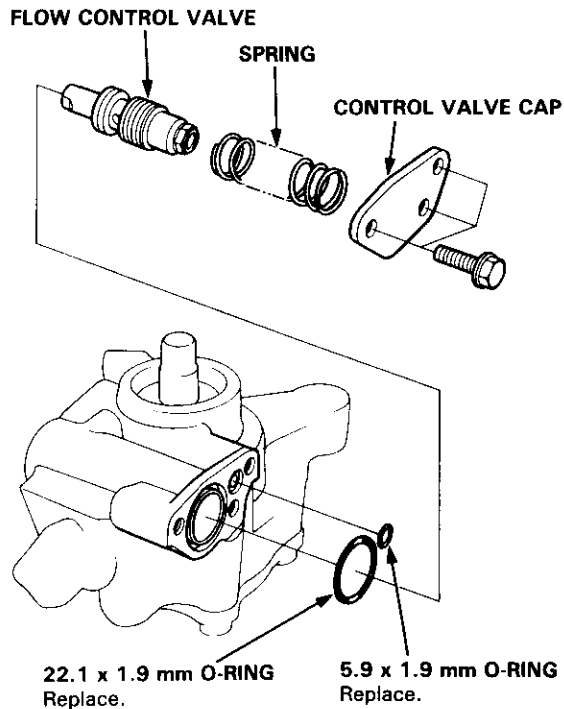

3. Check for wear, burrs, and other damage to the edges of the grooves in the flow control valve.

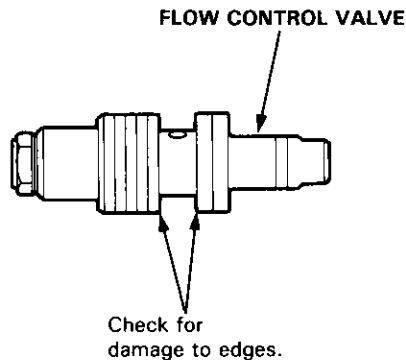

4. Slip the flow control valve back in the pump and check that it moves in and out smoothly.

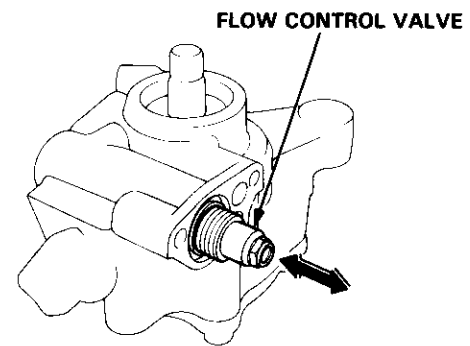

If OK, go on to step 5; if not, replace the flow control valve:

- The original valve was selected for a precise fit in the pump housing bore, so make sure the new one has the same identification mark.

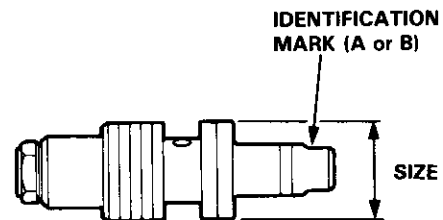

Mark	Part Name	Size mm (in)
A	FLOW CONTROL VALVE A	17.991 – 17.996 (0.7083 – 0.7085)
B	FLOW CONTROL VALVE B	17.996 – 18.001 (0.7085 – 0.7087)

(cont'd)

Steering Pump

Flow Control Valve Inspection and Replacement (cont'd)

5. Attach a hose to the end of the flow control valve as shown.

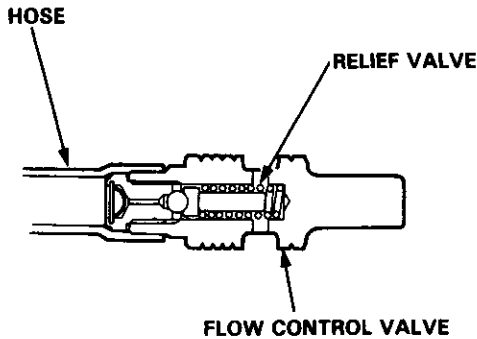

6. Submerge the flow control valve in a container of power steering fluid or solvent, and blow in the hose. If air bubbles leak through the relief valve, replace or repair it as follows.

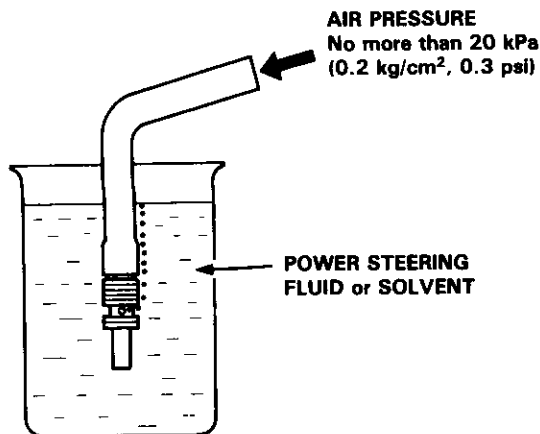

7. Clamp the bottom end of the flow control valve in a vise with soft jaws.
8. Unscrew the seat in the top end of the flow control valve, and remove any shims, the relief check ball, relief valve and relief valve spring.

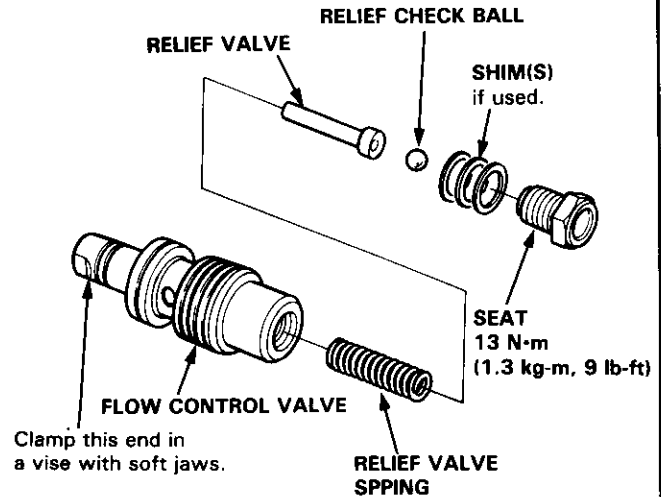

9. Clean all the parts in solvent, dry them off then reassemble and retest the flow control valve.

NOTE: If necessary, relief pressure is adjusted at the factory by adding shims under the check ball seat. If you found shims in your valve, be sure you reinstall as many as you took out.

10. Install the flow control valve in the reverse order of removal.

NOTE:

- Coat the flow control valve with power steering fluid, then install it and spring.
- When replacing the flow control valve, be sure the replacement flow control valve has the same identification letter as the original flow control valve.

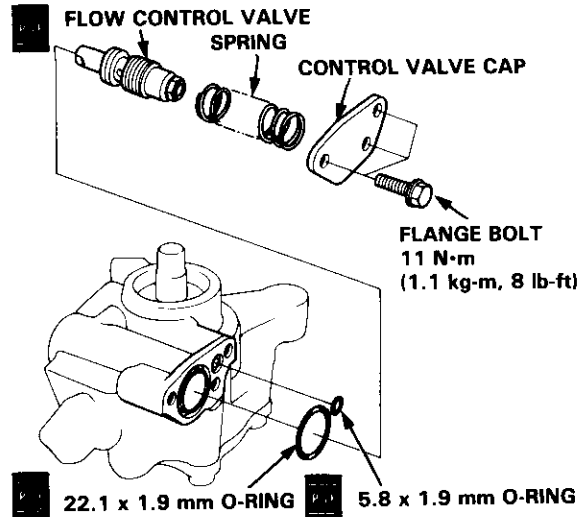



Disassembly

CAUTION: The pump components are made of aluminum. Be careful not to damage them when servicing.

1. Remove the pump from car (see page 17-96).
2. Remove the pulley (see page 17-96).
3. Remove the flow control valve (see page 17-97).
4. Remove the inlet joint and 13 x 1.9 mm O-ring.

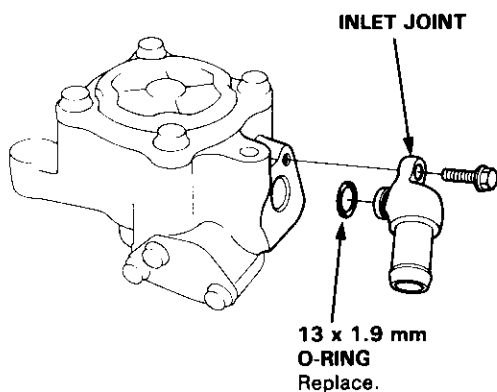

5. Remove the pump cover and O-ring.

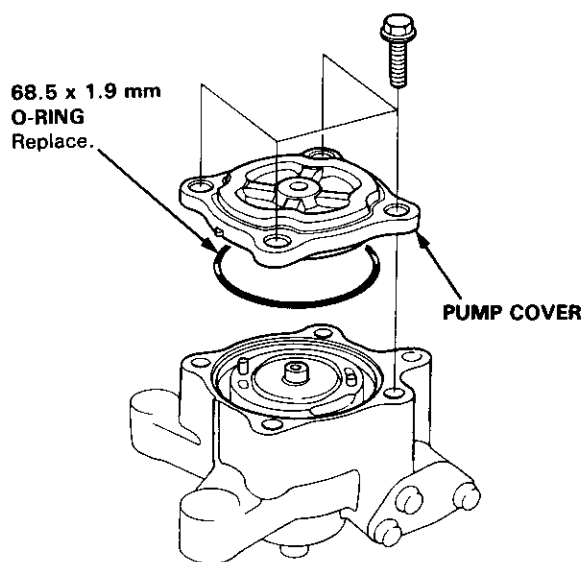

6. Remove the pump cam ring from the pump housing.

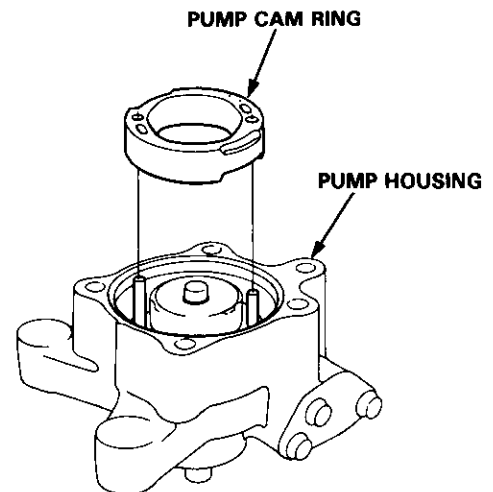

7. Remove the pump rotor and pump vanes.

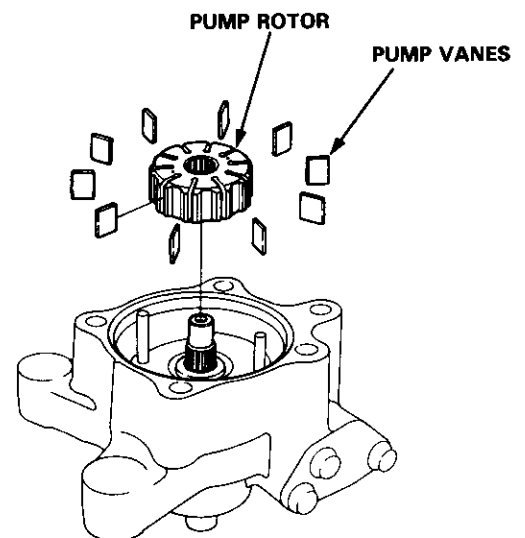

(cont'd)

Steering Pump

Disassembly (cont'd)

8. Remove the two rollers from the side plate.
9. Remove the side plate and preload spring.

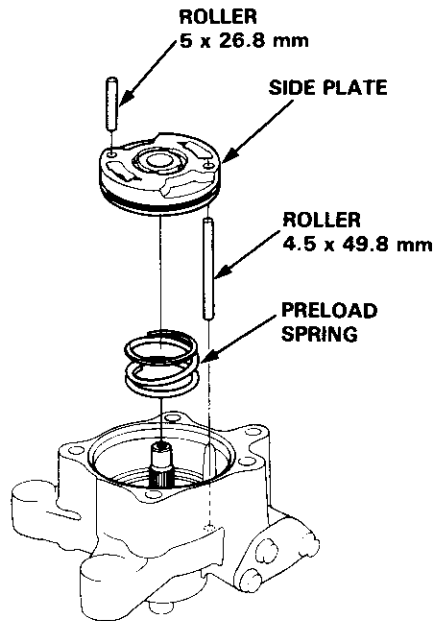

10. Remove the O-rings from the side plate.

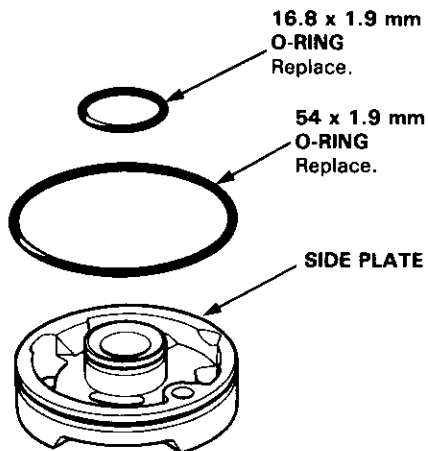

11. Remove the circlip, then remove the drive shaft from the pump housing using a plastic hammer.
12. Remove the pump seal spacer and oil seal.

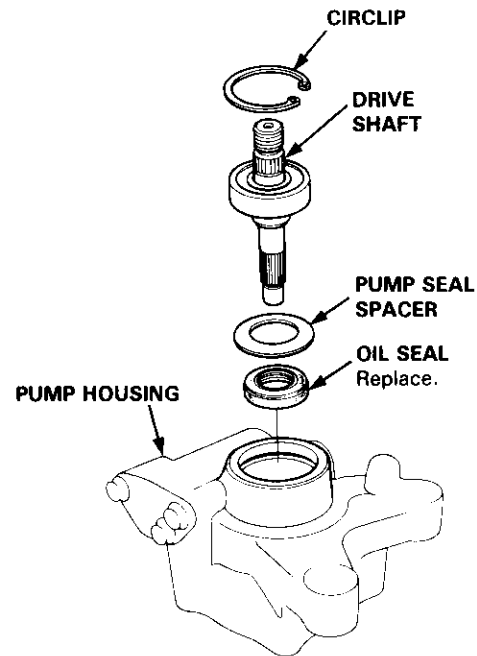

13. Inspect the bearing by rotating the outer race slowly. If any play or roughness is felt, it must be replaced. Perform step 14 and 15.

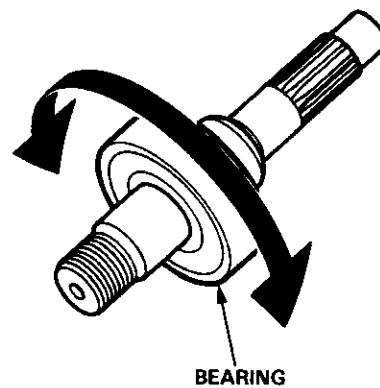



14. Remove the bearing using the special tool and press as shown.

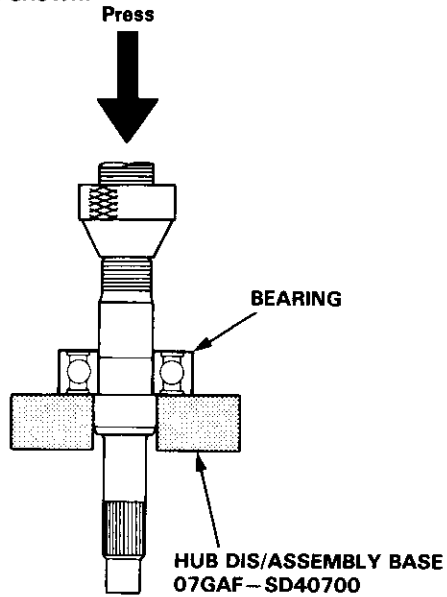

15. Install the new bearing using the press and special tool as shown.

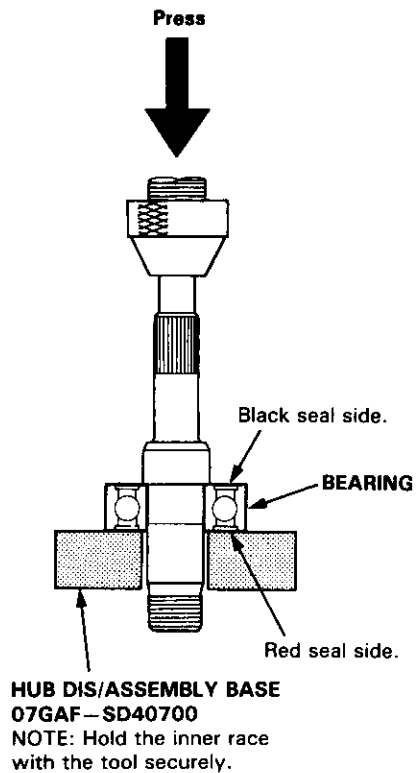

Steering Pump

Illustrated Index

CAUTION: Pump components are made of aluminum. Be careful not to damage them when servicing.

NOTE:

- Clean all of the disassembled parts thoroughly.
- Replace all O-rings and seals. Do not dip new O-rings and seals in solvent; coat O-rings with power steering fluid before installation, and make sure they stay in place during reassembly.
- If any part denoted with an asterisk (*) is worn or damaged, replace the complete pump.

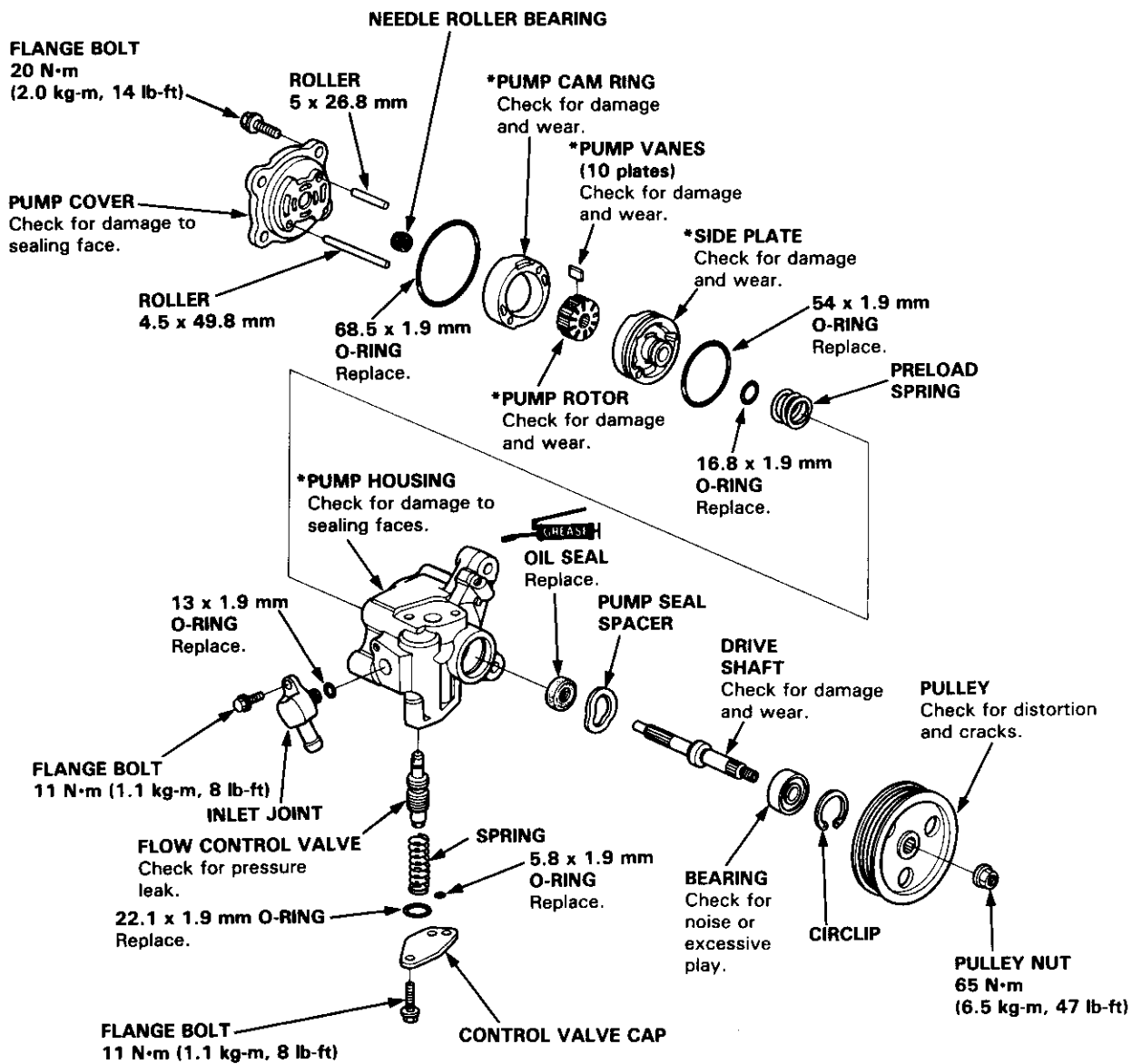



Assembly

1. Coat the lip of the new oil seal with steering grease (Honda P/N 08733-B070E).
2. Install the new oil seal in the pump housing by hand.
3. Install the pump seal spacer, then install the drive shaft in the pump housing using the special tools.
4. Install the circlip with its tapered side facing out.

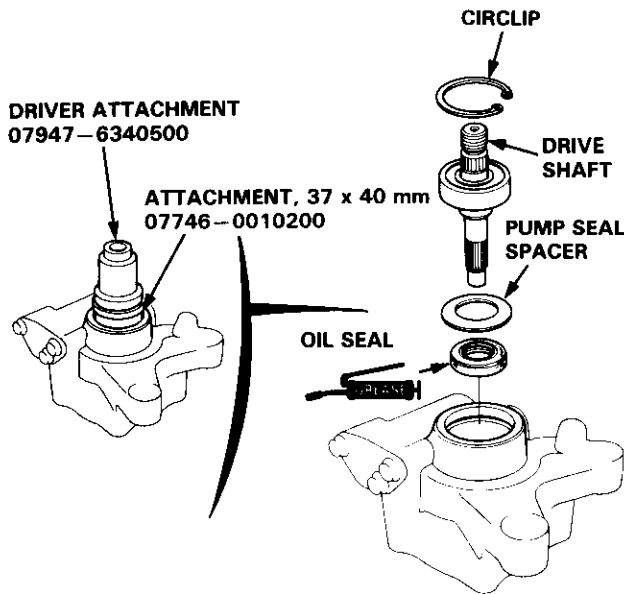

5. Coat the side plate grooves with power steering fluid, then position the 16.8 x 1.9 mm and 54 x 1.9 mm O-rings on the side plate.

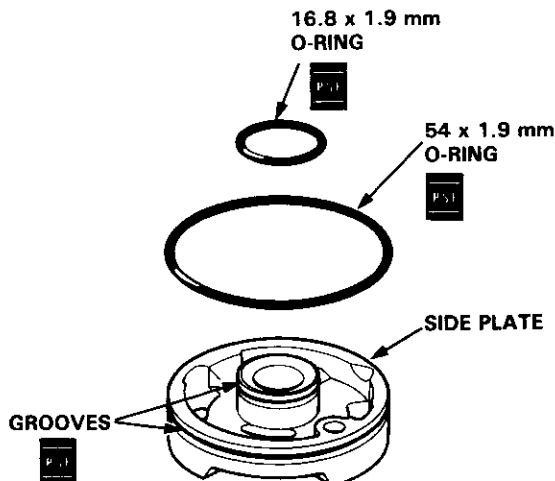

6. Install the preload spring in the pump housing.
7. Set the 4.5 x 49.8 mm roller in the 4.5 mm hole in the pump housing.
8. Set the side plate over the roller and install it on the pump housing.
9. Set the 5 x 26.8 mm roller in the 5 mm hole in the side plate.

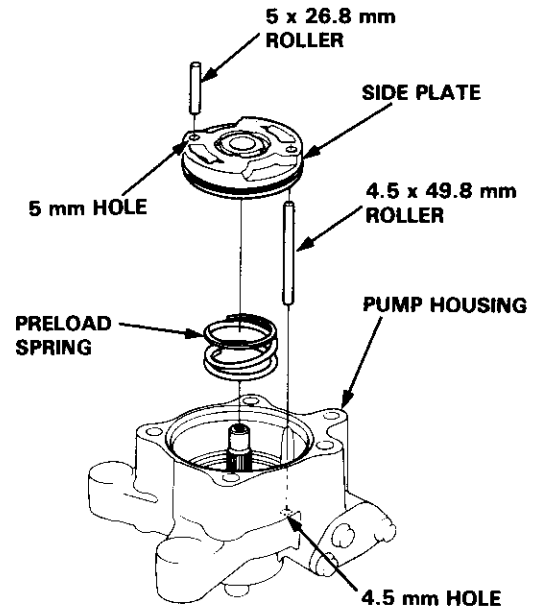

10. Assemble the pump rotor to the drive shaft with the "O" mark on the rotor facing upward.
11. Set the 10 vanes in each groove in the rotor.

NOTE: Be sure that the round end of the vanes is in contact with the sliding surface of the cam ring.

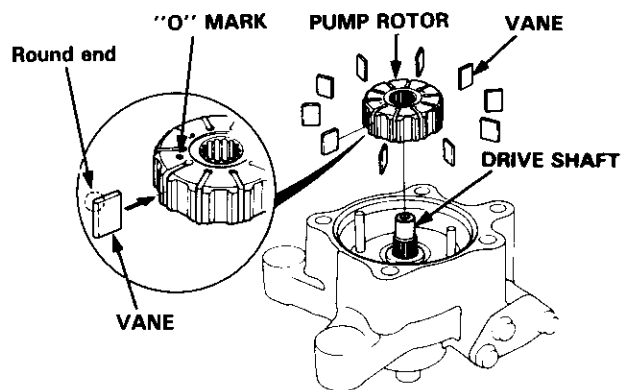

(cont'd)

Steering Pump

Assembly (cont'd)

12. Set the pump cam ring over the two rollers with the "P" mark on the cam ring upward.
13. Apply clean power steering fluid to the vanes and pump cam ring.

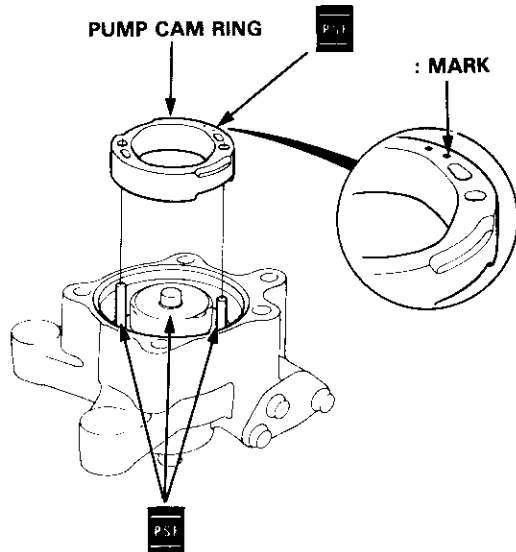

14. Install the 68.5 x 1.9 mm O-ring on the pump cover.
15. Align the roller set holes in the pump cover with the rollers.
16. Align the projection on the pump housing and the projection on the pump cover, then tighten the four bolts.

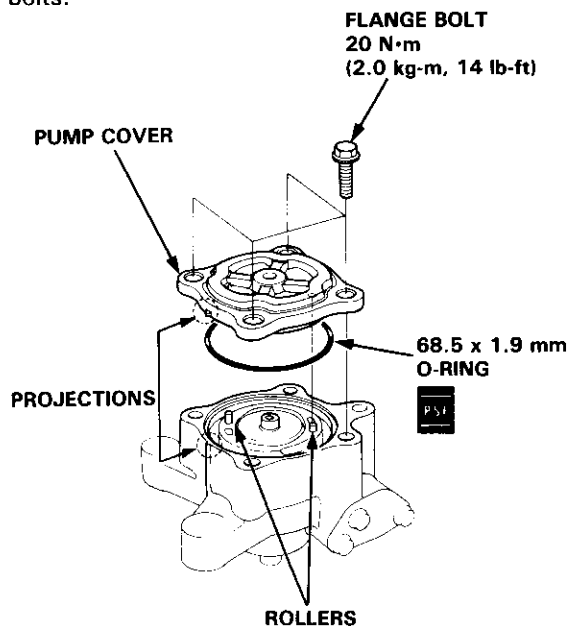

17. Set the 13 x 1.9 mm O-ring on the inlet joint, and install the inlet joint on the pump housing.

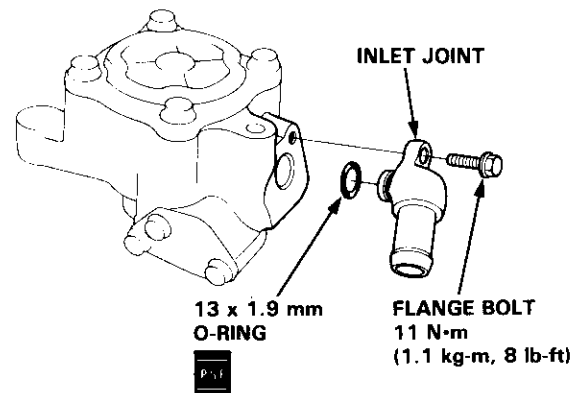

18. Install the flow control valve (see page 17-98).
19. Install the pulley (see page 17-96) and check that the pump turns smoothly by turning the pulley.



Steering Gearbox

Index

CAUTION: Before disassembling the gearbox, wash it off with solvent and a brush.

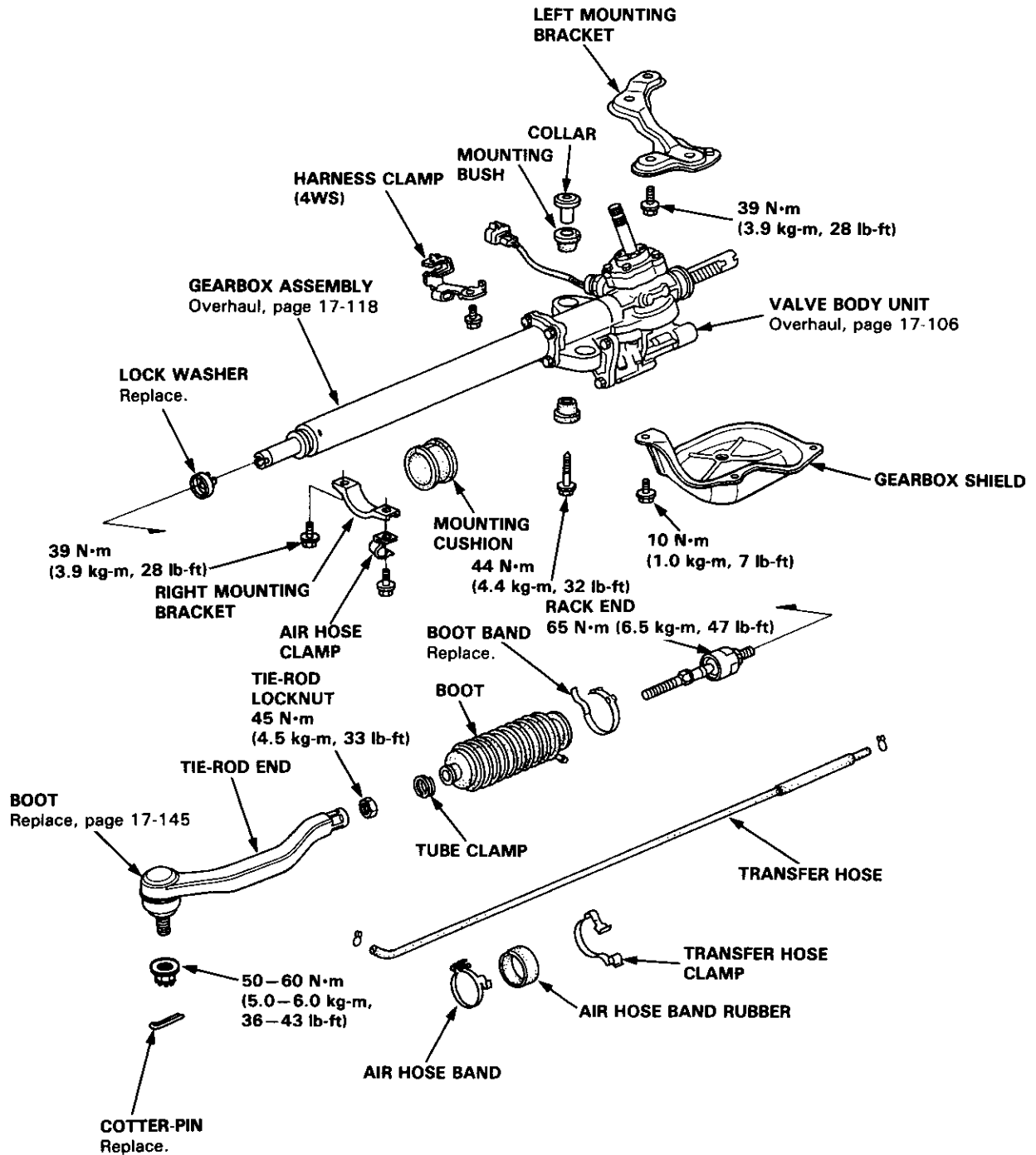

Steering Gearbox

Valve Body Unit

Removal

1. Drain the power steering fluid (see page 17-77).
2. Remove the gearbox shield.

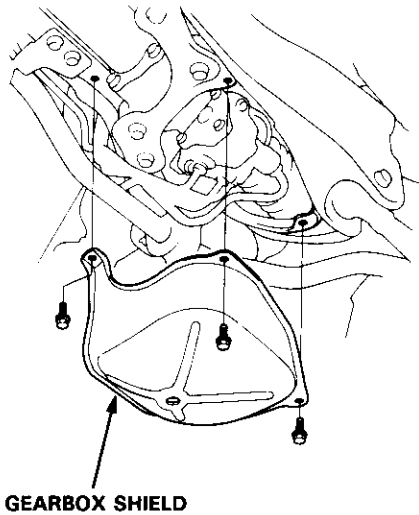

3. Using solvent and a brush, wash any oil and dirt off the valve body unit, its lines, and that end of the gearbox. Blow dry them with compressed air.
4. Using flare nut wrenches, disconnect the four lines from the valve body unit.

- A:** To oil cooler: 17 mm wrench
B: To power steering speed sensor: 12 mm wrench
C: To reservoir: 12 mm wrench
D: From pump: 14 mm wrench

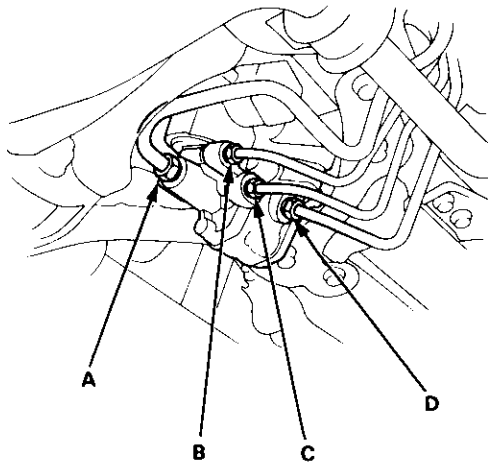

5. Remove the two 8 mm flange bolts and remove the valve body unit from the gearbox.
6. Remove the O-rings and port orifices from the gearbox.

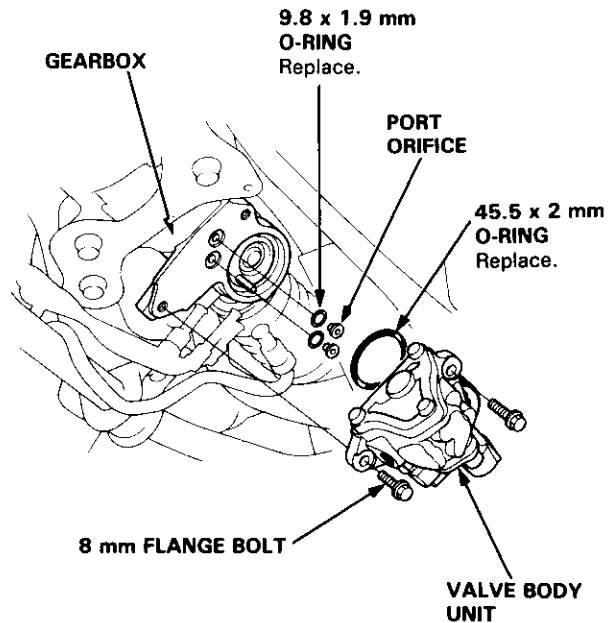



Valve Body Unit

Disassembly

1. Remove the three 6 mm flange bolts, then remove the valve body cap from the valve body.
2. Remove the cap seal from the valve body cap.

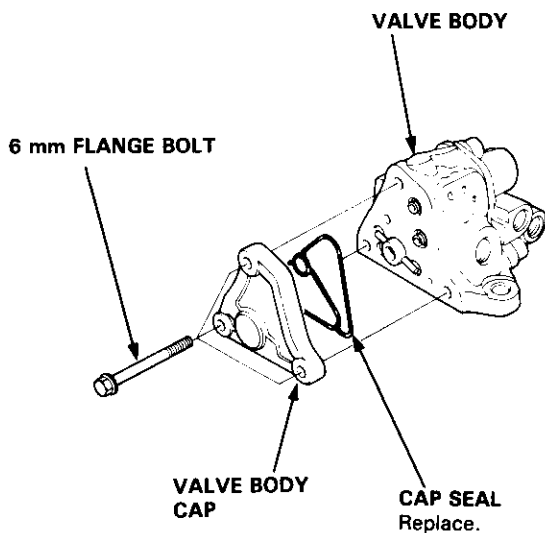

3. Remove the pressure control valve and valve spring from the valve body.

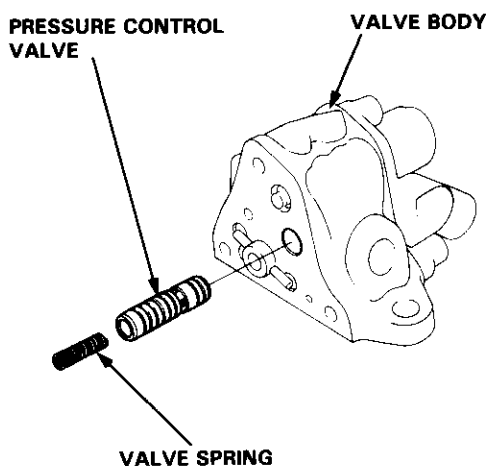

4. Check the pressure control valve:

- Inspect its surface for scoring or scratches.
- Slip it back into the valve body, and make sure it slides smoothly without drag and without side play.

PRESSURE CONTROL VALVE

Check for scoring or scratches, and rough operation.

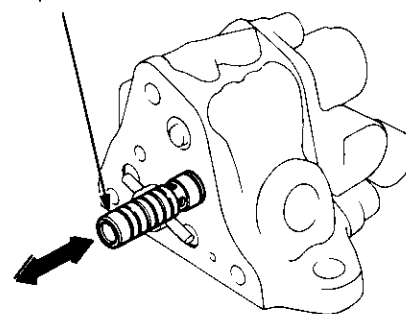

NOTE: If the valve body is damaged, replace the valve body unit (valve body, pressure control valve, gain control valve, 4-way valve) as an assembly.

5. Remove the gain control valve and valve spring from the valve body.

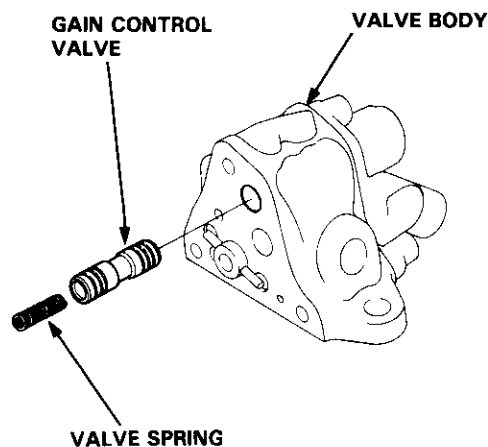

(cont'd)

Steering Gearbox

Valve Body Unit (cont'd)

6. Check the gain control valve:

- Inspect its surface for scoring or scratches.
- Slip it back into the valve body and make sure it slides smoothly without drag and without side play.

GAIN CONTROL VALVE

Check for scoring, scratches, or rough operation.

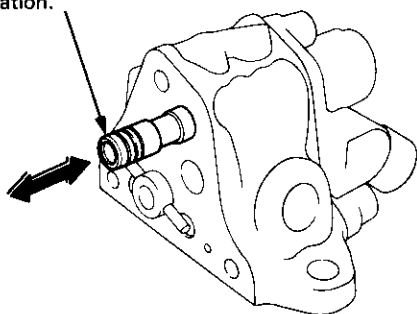

NOTE: If the valve body is damaged, replace the valve body unit (valve body, pressure control valve, gain control valve, 4-way valve) as an assembly.

7. Separate the valve body and port housing.

8. Remove the port seal and dowel pins from the port housing.

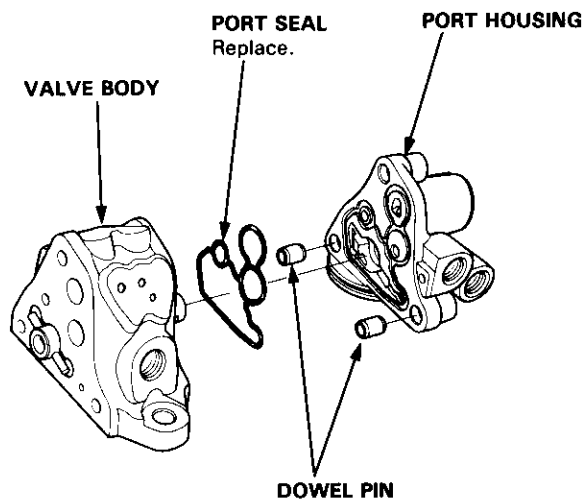

9. Remove the rollers from the 4-way valve by pushing the valve out one side of the valve body, and then the other.

NOTE: When removing the rollers, hold the plungers with your fingers to keep them from popping out.

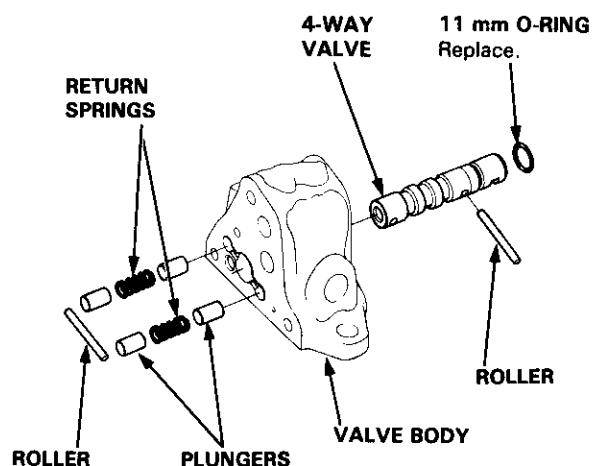

10. Remove the plungers, return springs and 4-way valve from the valve body.

11. Remove the 11 mm O-ring from the 4-way valve.

12. Check the plungers.

- Inspect their surface for scoring or scratches.
- Slip each plunger into the valve body, and make sure it slides smoothly, without drag or side play. If any plunger is damaged, replace it.

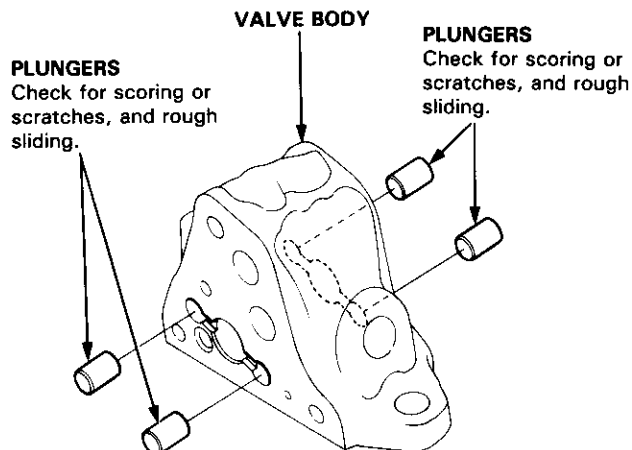



13. Check the 4-way valve.

- Inspect its surface for scoring or scratches.
- Slip it into the valve body, and make sure it slides smoothly, without drag or side play.

4-WAY VALVE
Check for scoring,
scratches, or rough
operation.

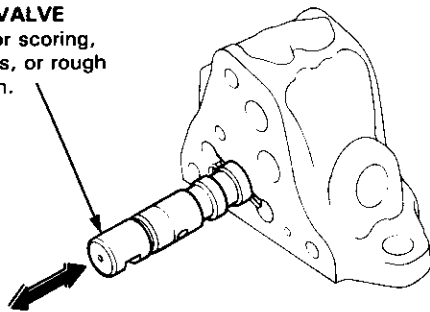

NOTE: If the valve body is damaged, replace the valve body unit (valve body, pressure control valve, gain control valve, 4-way valve) as an assembly.

14. Using a 3 mm (1/64") drill bit, remove the sensor orifice and 3.4 m O-ring.

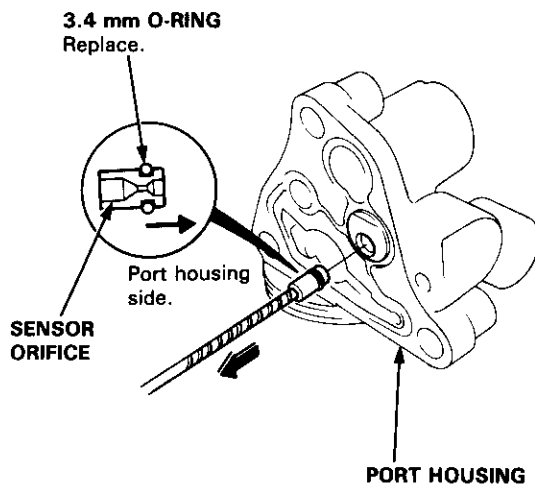

Steering Gearbox

Valve Body Unit

Assembly

Illustrated Index

1. Thoroughly clean the disassembled parts shown below.
2. Coat the plungers, pressure control valve, gain control valve and 4-way valve surfaces with power steering fluid.
3. Reassemble the parts in the reverse order of disassembly.

CAUTION:

- Replace the O-rings and seals with new ones.
- Do not dip the O-rings and seals in solvent.
- Apply the power steering fluid in the seal grooves to keep the seals in place.
-  : STEERING GREASE (Part Number 08733-B070E)

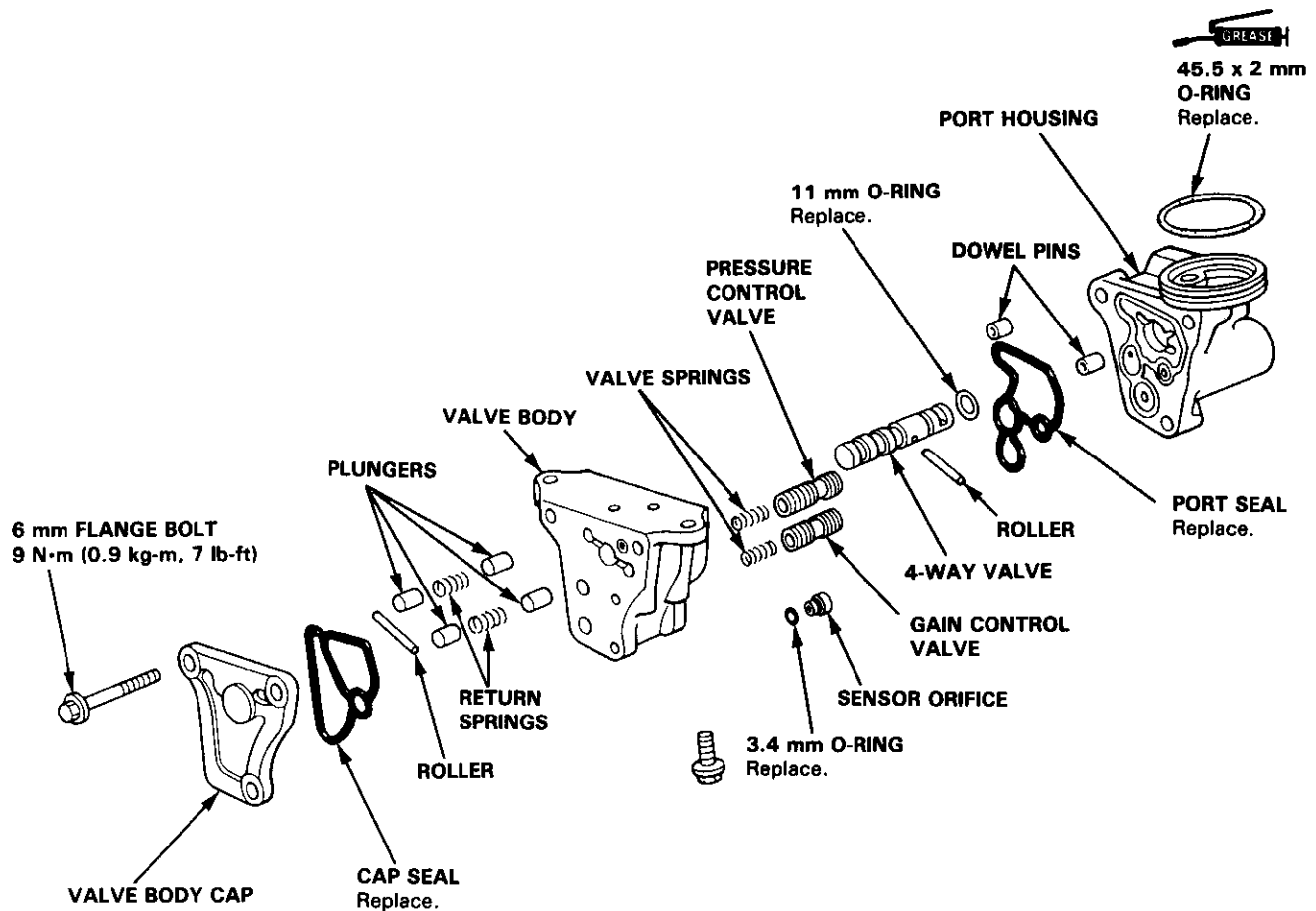

NOTE: If the valve body is damaged, replace the valve body unit (valve body, pressure control valve, gain control valve, 4-way valve) as an assembly.



- Coat the surface of the 4-way valve with power steering fluid, and install into the valve body.
- Coat the surface of the plungers with power steering fluid, and install the plungers, return springs and rollers on the valve body.

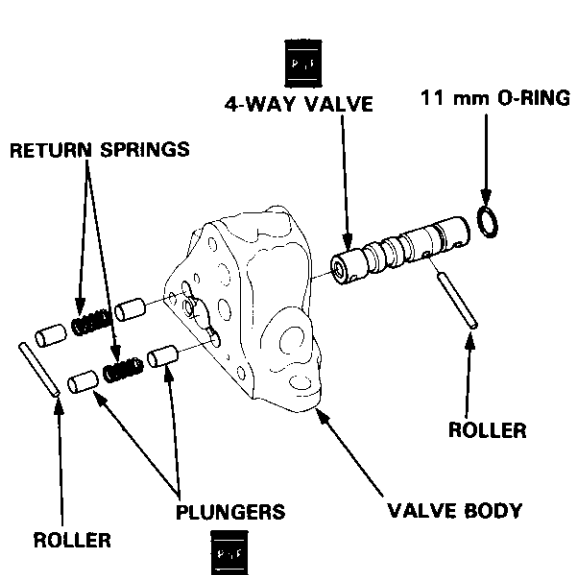

- Coat the port seal with power steering fluid, and install it in the groove of the port housing. Then install the valve body and port housing.

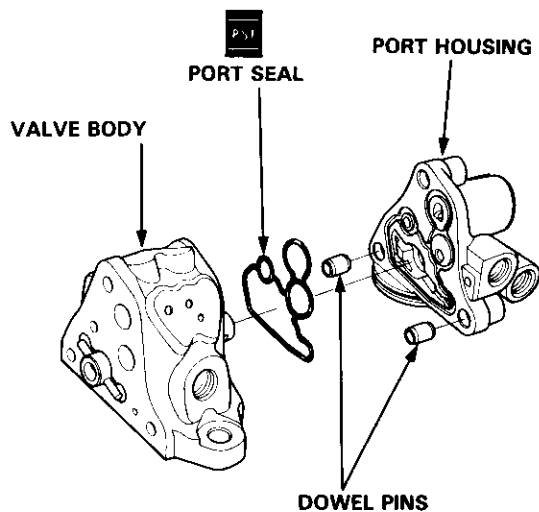

- Coat the pressure control valve and gain control valve with power steering fluid, and install them into the valve body.
- Install the valve springs.

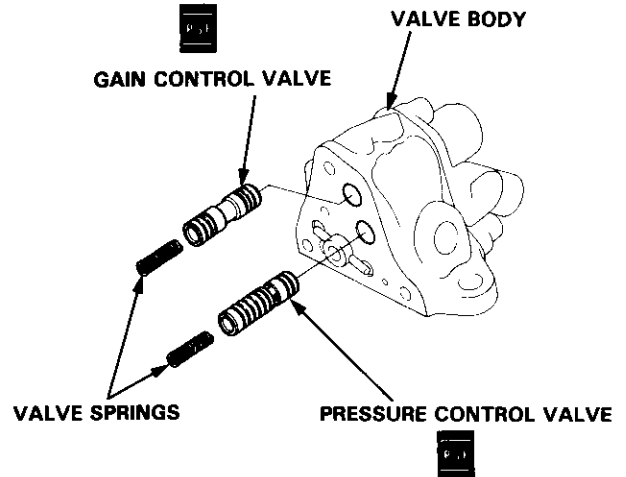

- Coat the cap seal with power steering fluid, and install it in the groove of the valve body cap.
- Install the valve body cap on the valve body with 6 mm flange bolts.

CAUTION: Make sure the mating surface of the valve body and cap are flush at the upper side.

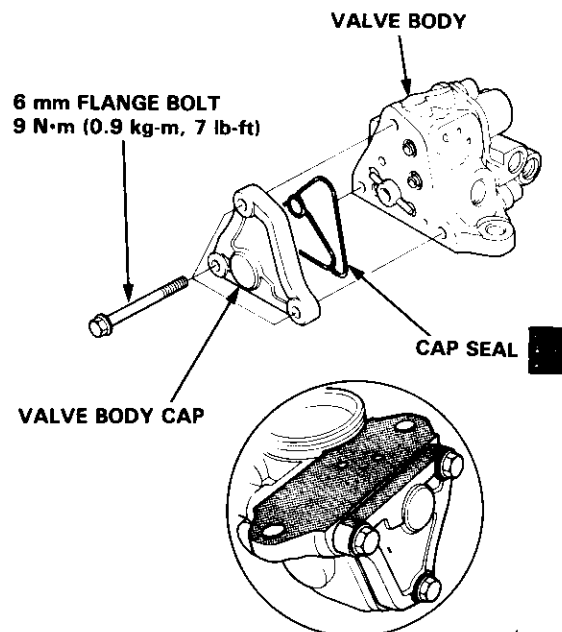

(cont'd)

Steering Gearbox

Valve Body Unit (cont'd)

11. Make sure the 4-way valve moves smoothly, and returns to neutral position.

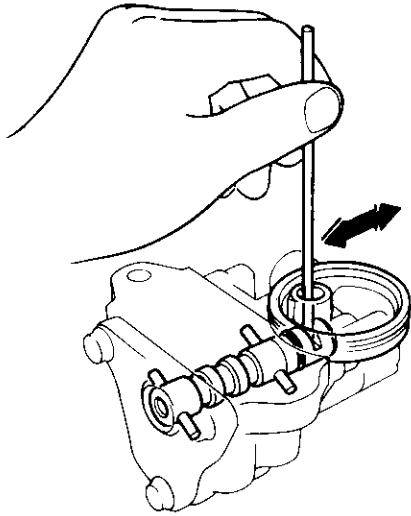

Installation

1. Coat the 9.8 x 1.9 mm O-rings with power steering fluid, and install them together with the orifices.
2. Install the valve body unit on the gear housing with the two 8 mm bolts.

CAUTION:

- When installing, be careful not to hit the pinion holder pin.
- Make sure the O-rings are in place and not pinched.

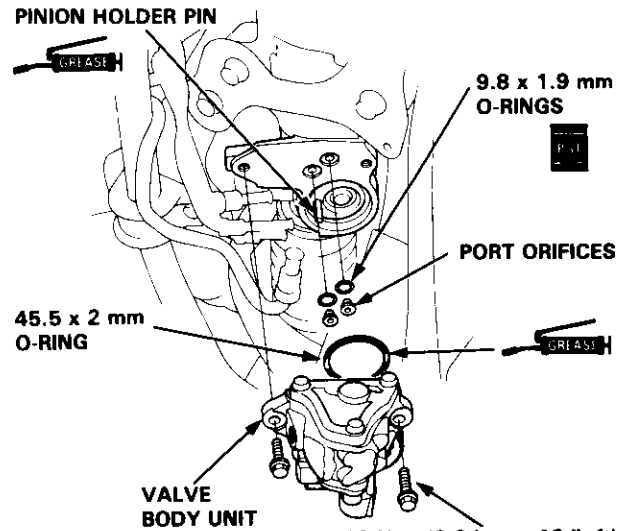

3. Connect the four lines to the valve body unit, using flare nut wrenches.

- A:** To oil cooler: 17 mm wrench
29 N·m (2.9 kg·m, 21 lb·ft)
- B:** To power steering speed sensor:
12 mm wrench
13 N·m (1.3 kg·m, 9 lb·ft)
- C:** To reservoir: 12 mm wrench
13N·m (1.3 kg·m, 9 lb·ft)
- D:** From pump: 14 mm wrench
38 N·m (3.8 kg·m, 28 lb·ft)

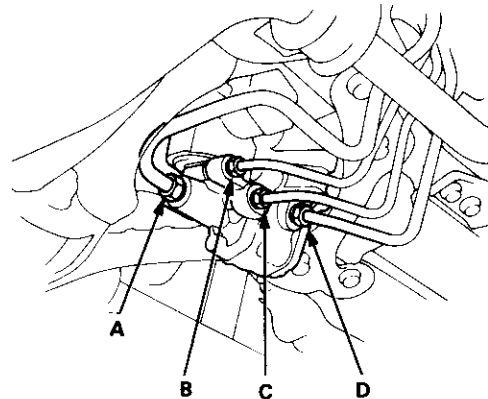



4. Fill the reservoir with power steering fluid and bleed air from the system by turning the steering wheel from lock to lock several times with the engine warm (see page 17-77).
5. Make sure there are no fluid leaks, then install the gearbox shield.
6. Recheck the fluid level in the reservoir.

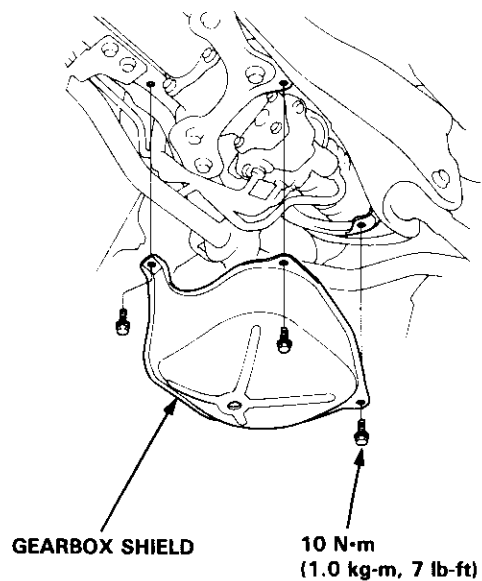

Steering Gearbox

Gearbox Removal

NOTE: Before removing the steering gearbox, align the front wheels straight ahead.

1. Drain the power steering fluid as described on page 17-77.
2. Raise the front of car and support on safety stands in the proper locations (see section 1).
3. Remove the front wheels.
4. Remove the cotter pin from the castel nut and remove the nut.
5. Install a 12 mm hex nut on the ball joint. Be sure that the 12 mm hex nut is flush with the ball joint pin end, or the threaded section of the ball joint pin might be damaged by the ball joint remover.

NOTE: Remove the ball joint using the Ball Joint Remover. Refer to page 18-13 for how to use the ball joint remover.

6. Separate the tie-rod ball joint and knuckle using the special tool.

CAUTION: Avoid damaging the ball joint boot.

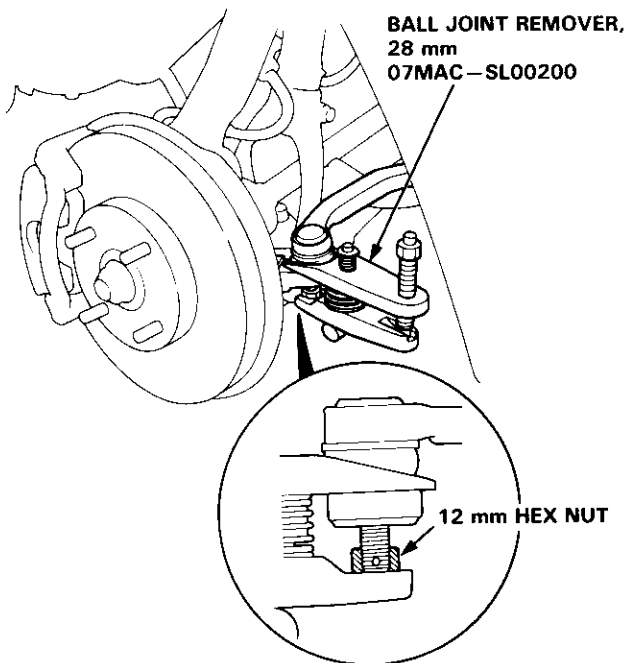

7. Remove the self-locking nuts that connect the exhaust pipe A to the three way catalytic converter, and the exhaust pipe A to the exhaust manifold.
8. Disconnect the heated oxygen sensor connector (H23A1 and H22A1 engine) and remove the exhaust pipe A.

CAUTION: Replace the exhaust gasket and self-locking nuts when you reinstall the pipe.

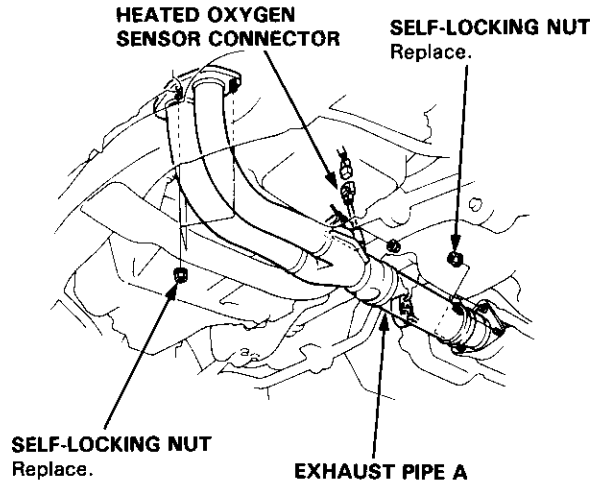

9. Automatic transmission only.

- Remove the shift cable holder and disconnect the shift cable from the shift control shaft.

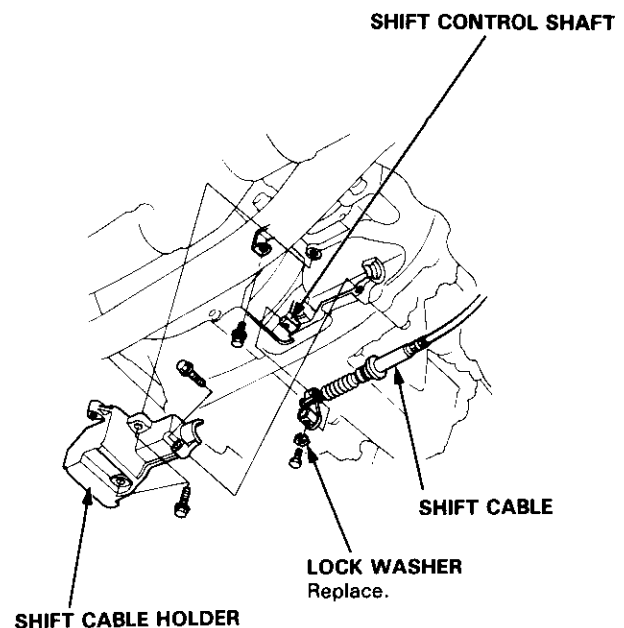



10. Remove the center beam.

NOTE: Replace the self-locking bolts if you can easily thread them in.

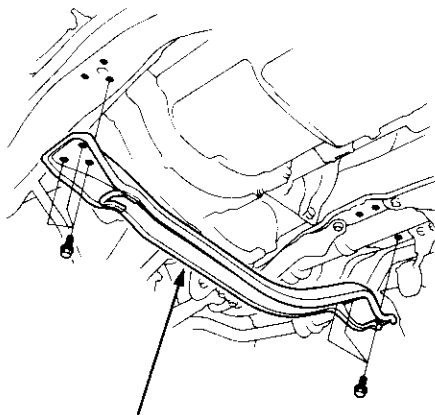

CENTER BEAM

11. Remove the gearbox shield.

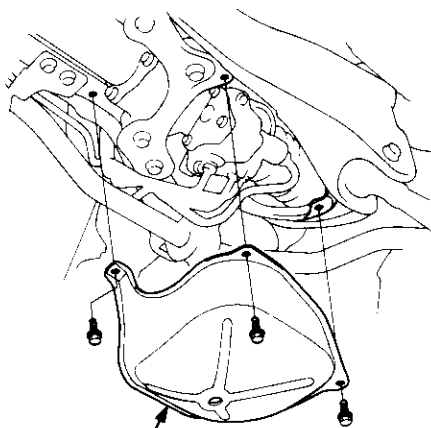

GEARBOX SHIELD

12. Using solvent and a brush, wash any oil and dirt off the valve body unit, its lines, and the end of the gearbox. Blow dry them with compressed air.

CAUTION: After disconnecting the hoses and pipes, plug or seal the hoses and pipes with a piece of tape or equivalent to prevent foreign material from entering the valve body unit.

13. Using flare nut wrenches, disconnect the four lines from the valve body unit.

- A: To oil cooler: 17 mm wrench
- B: To power steering speed sensor: 12 mm wrench
- C: To reservoir: 12 mm wrench
- D: From pump: 14 mm wrench

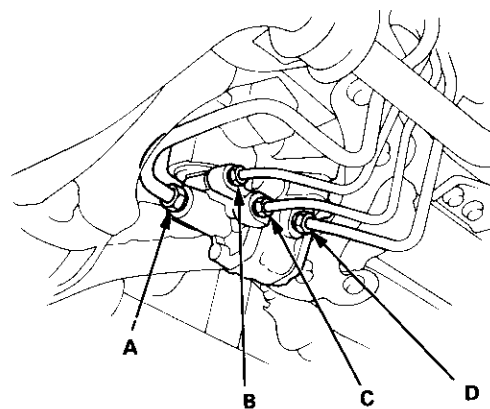

4WS:

14. Cut the wire tie from the cover, then remove the cover from the front sub steering angle sensor.

CAUTION: Use care when cutting the wire tie so as not to cut into the wire harness.

15. Remove the sensor wire harness from the clamp and disconnect the connector.

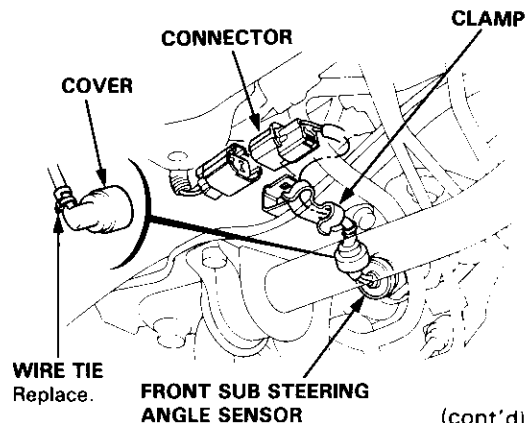

(cont'd)

Steering Gearbox

Gearbox Removal (cont'd)

16. Lock the steering shaft with ignition key to keep the steering shaft position.
17. Remove the steering joint bolt, and move the joint toward the column.

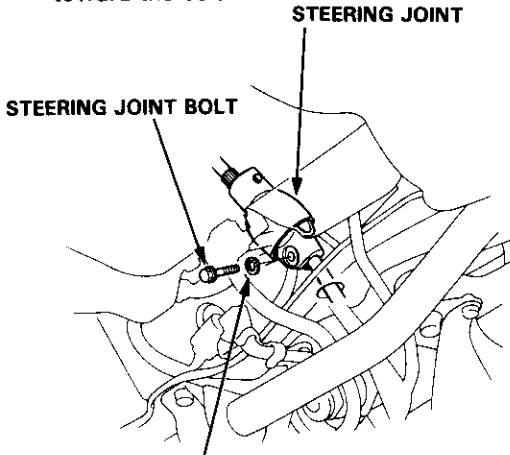

TOOTHED LOCK WASHER

18. Remove the left mounting bracket first, then remove the right mounting brackets.

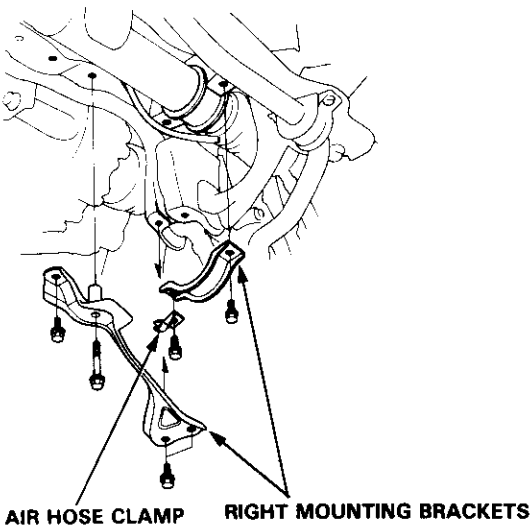
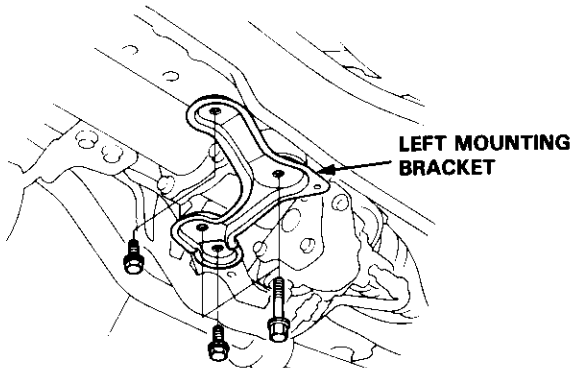

19. Remove the left-tie rod end, then slide the rack all the way to the right.
20. Pull the steering gearbox assembly all the way down to clear the pinion shaft from the bulkhead.
21. Move the steering gearbox assembly to the right so the left rack end clears the rear beam.
22. Hold the steering gearbox assembly and slide the rack all the way to the left. Place the left rack end below the rear beam.
23. Move the steering gearbox assembly to the left and tilt the left side down to remove it from the car.

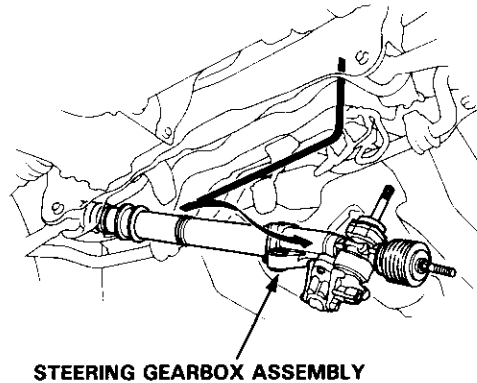

CAUTION: Be careful not to bend or damage the four power steering lines when removing the gearbox assembly.



Illustrated Index

- Thoroughly clean all disassembled parts.
- Always replace O-rings and seals.
- Replace parts with damaged sliding surfaces.
- Do not dip seals and O-rings in solvent; coat O-rings with power steering fluid or steering grease, make sure they stay in position during reassembly, and use the appropriate special tools to install them where necessary.
-  : STEERING GREASE (P/N 08733-8070E)

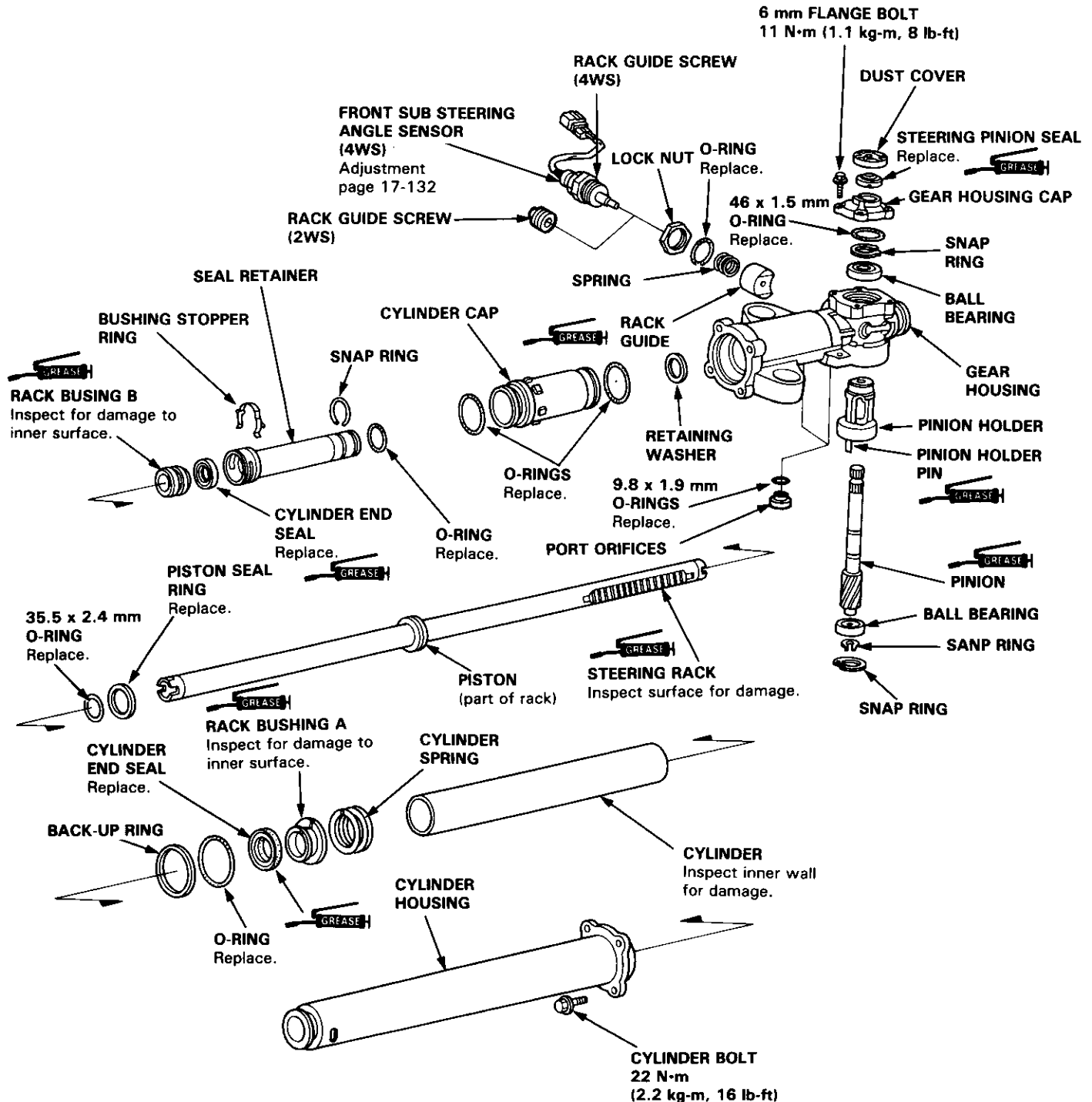

Steering Gearbox

Overhaul

1. Remove the two 8 mm flange bolts and remove the valve body unit from the gearbox.
2. Remove the O-rings and port orifices from the gearbox.

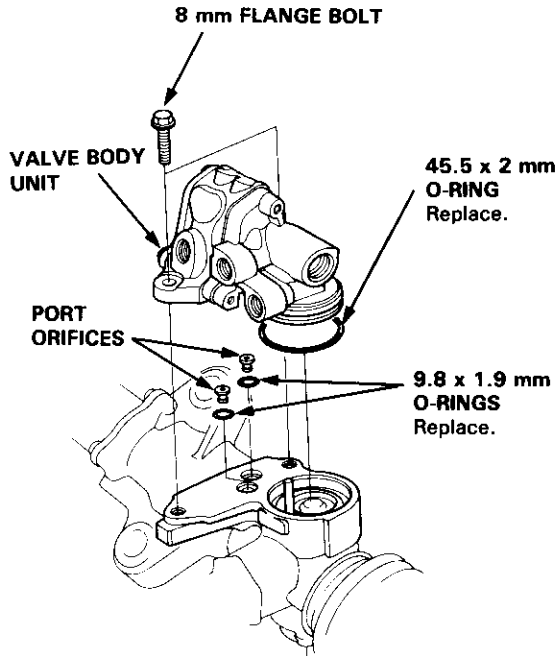

3. Loosen the locknut and remove the rack guide screw.
4. Remove the spring and rack guide from the gear housing.

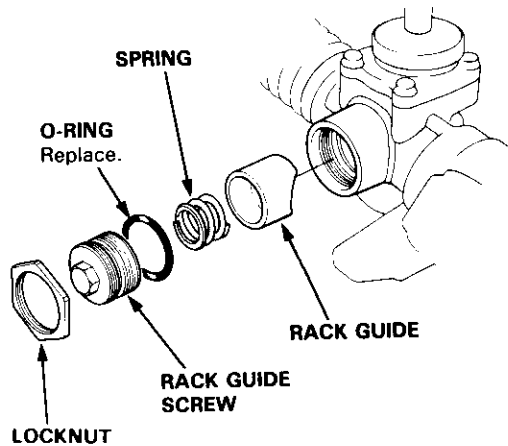

4WS:

5. Loosen the locknut and remove the rack guide screw/front sub steering angle sensor assembly.
6. Remove the spring and rack guide from the gear housing.

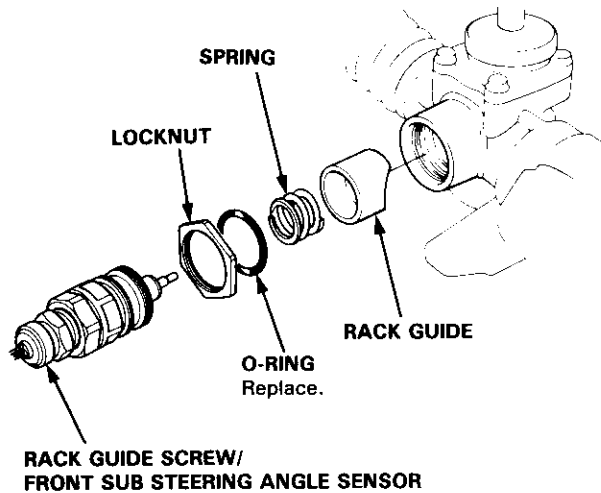

7. Remove the rack guide screw, O-ring and locknut from the front sub steering angle sensor.

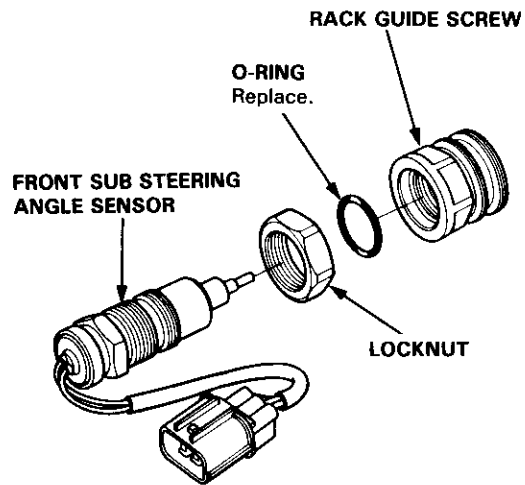



8. Carefully clamp the gearbox in a vise with soft jaws.

9. Remove the tie-rod end.

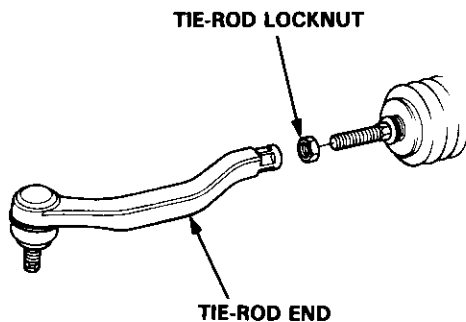

10. Remove the boot bands and tube clamps. Pull the dust seals away from the ends of the gearbox.

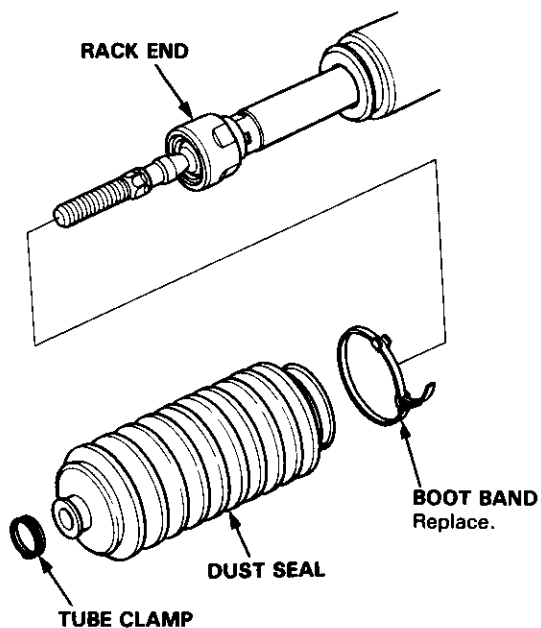

11. Hold the steering rack with a wrench and unscrew the rack end with a wrench.

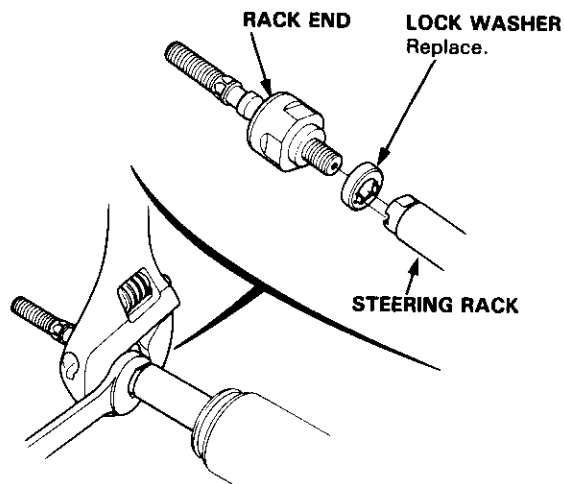

12. Remove the dust cover.

13. Remove the gear housing cap from the gear housing by removing the four 6 mm flange bolts.

14. Remove the steering pinion seal from the gear housing cap.

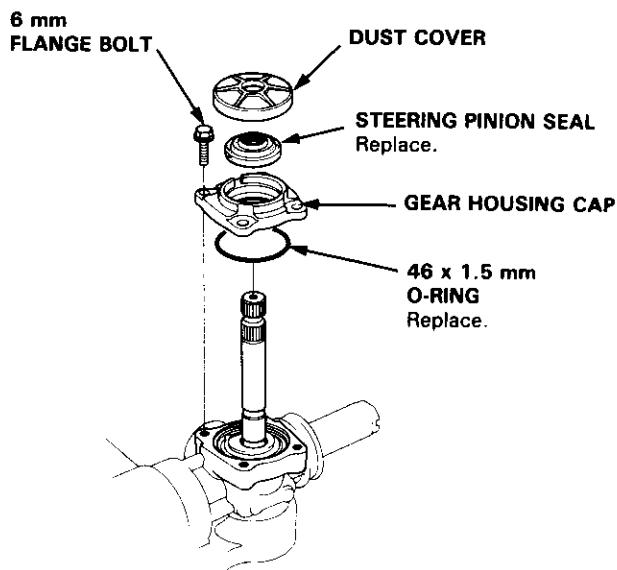

(cont'd)

Steering Gearbox

Overhaul (cont'd)

15. Push the right end of the rack back into the cylinder housing so the smooth surface that rides against the seal won't be damaged.

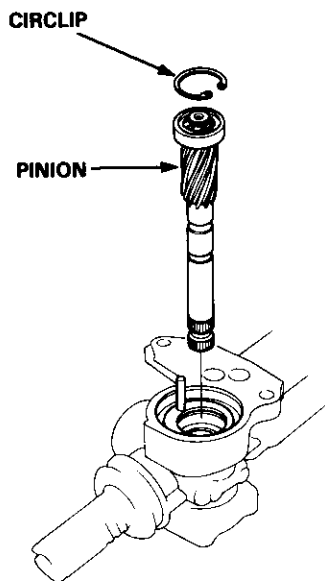

16. Check the ball bearing of the pinion for play; if it is good, go on step 17. If the bearing is noisy or has excessive play, replace the bearing.

- Remove the snap ring.

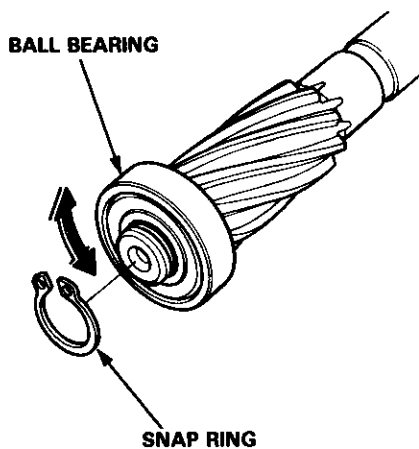

- Remove the ball bearing using a commercially available bearing puller.

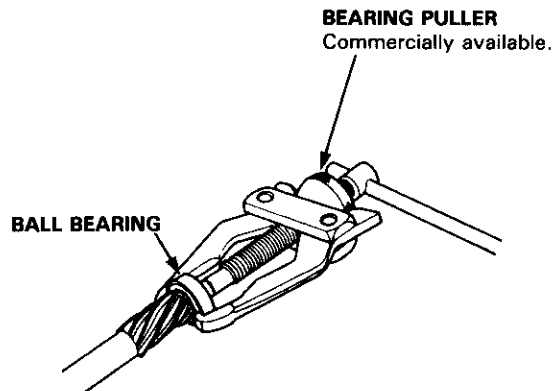

- Install the ball bearing on the pinion using a press and the special tools.

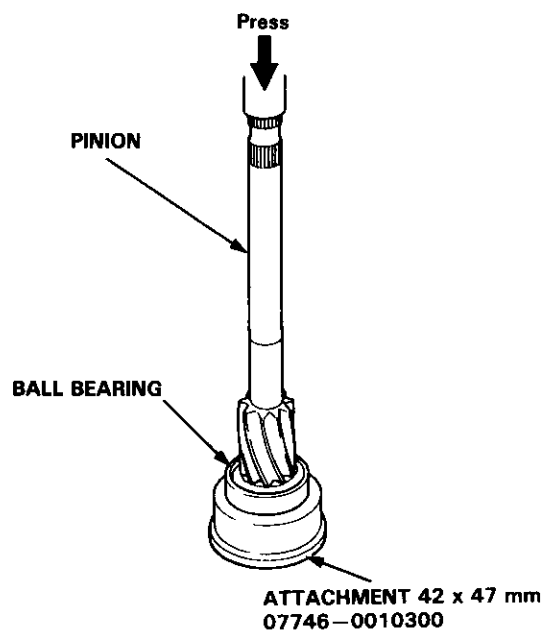



- Install the snap ring on the pinion.

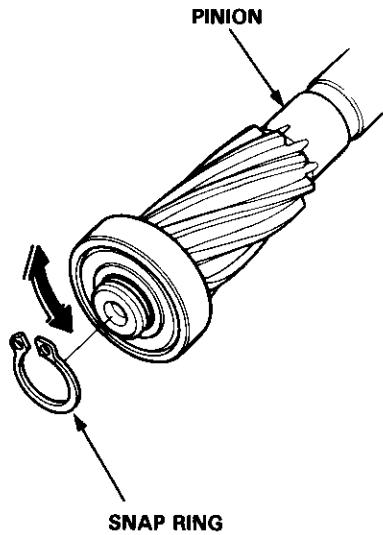

17. Remove the four cylinder bolts from the end of the cylinder housing, then slide the housing off the rack.
18. Remove the O-ring, back-up ring, steering rack bushing A and cylinder spring.

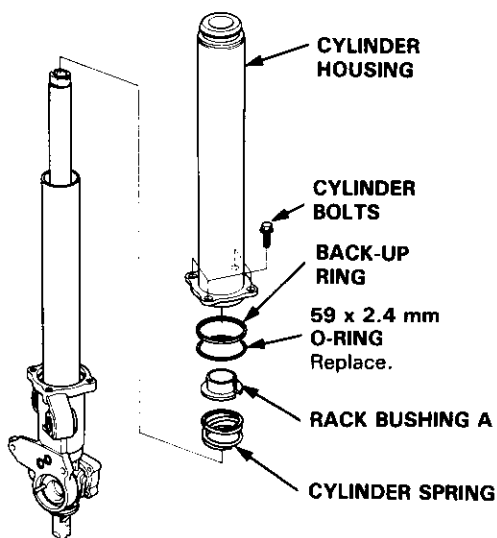

19. Remove the cylinder end seal from the cylinder housing.

NOTE: Use your fingers or a wooden stick to avoid damaging the housing.

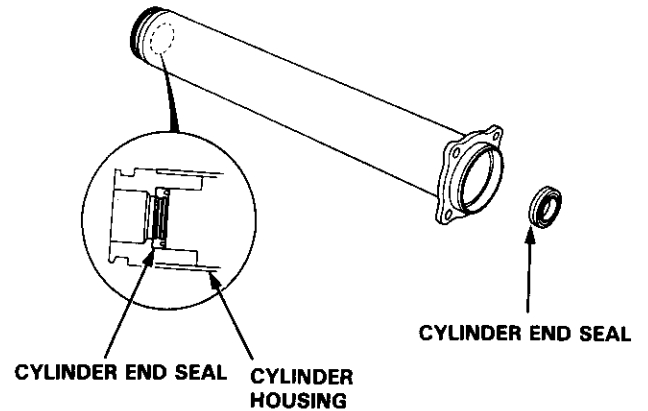

20. Remove the cylinder, seal retainer, cylinder cap and steering rack from the gear housing.

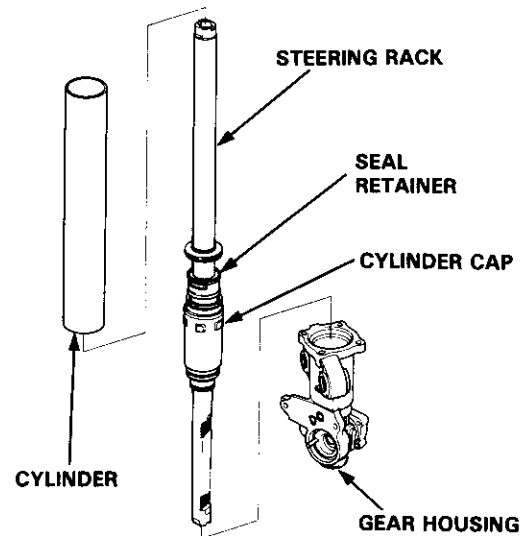

(cont'd)

Steering Gearbox

Overhaul (cont'd)

21. Remove the retainer washer from the gear housing.

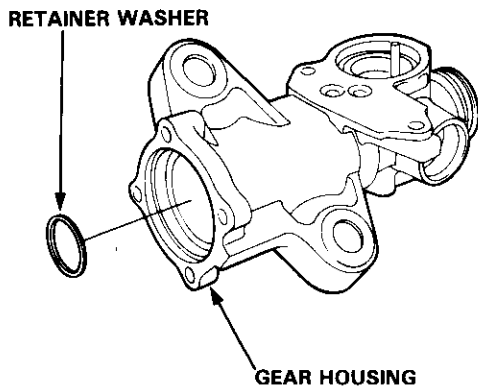

22. Check the pinion holder for free movement, excessive play and rough movement; if it is good go on step 23.

If it is damaged, or if dirt has gone past the seal into the grease, replace the bearing.

- Remove the circlip from the pinion holder.

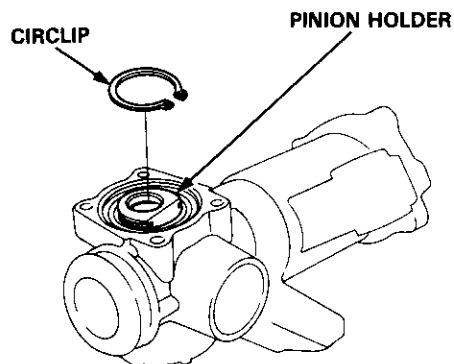

- Remove the pinion holder from the gear housing.
- Check the needle roller bearings in the pinion holder and gear housing for damage; if OK, pack the needle roller bearing with grease. If the bearings are damaged, replace them as a set.

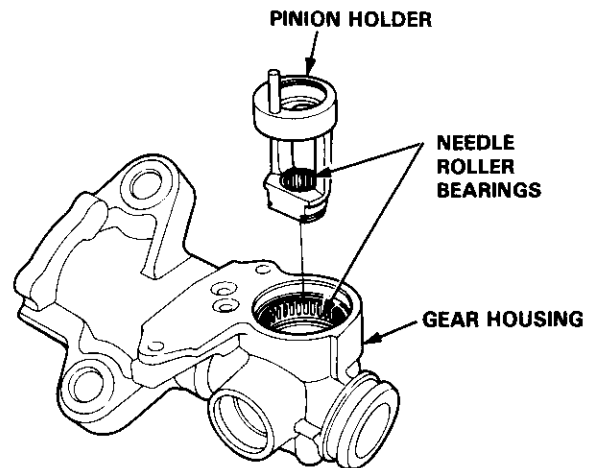

- Check the ball bearing for damage; if it is good, go on step 23.
- Remove the pinion ball bearing from the gear housing.

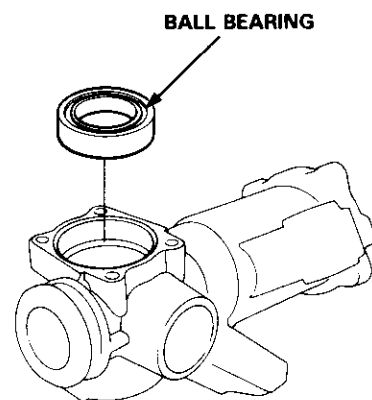



- Drive the new ball bearing into the gear housing using the special tools.

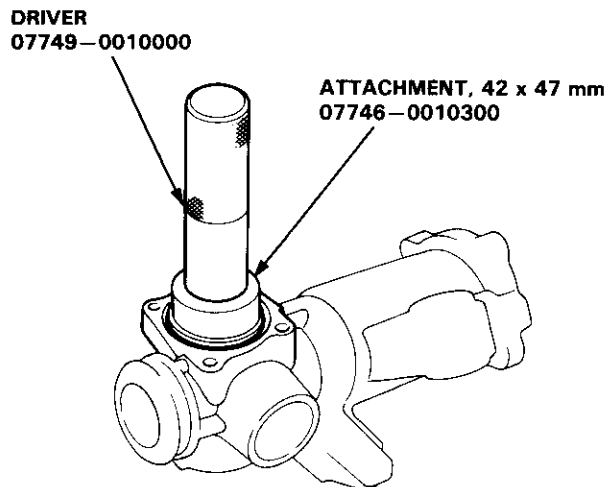

- Install the pinion holder in the gear housing.

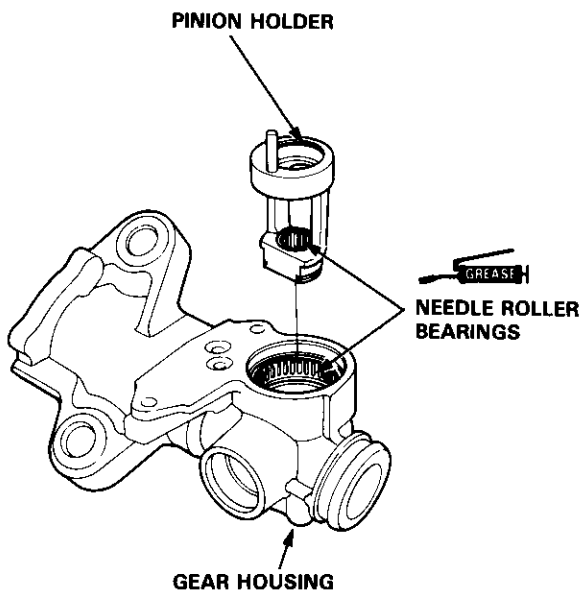

- Reinstall the circlip with its tapered side facing out.

NOTE: Circlip ends must be aligned with the flat area.

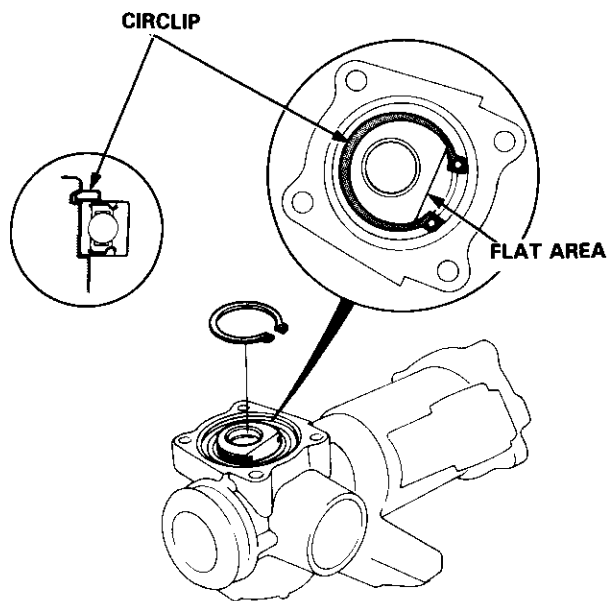

23. Remove the cylinder cap and seal retainer from the steering rack.

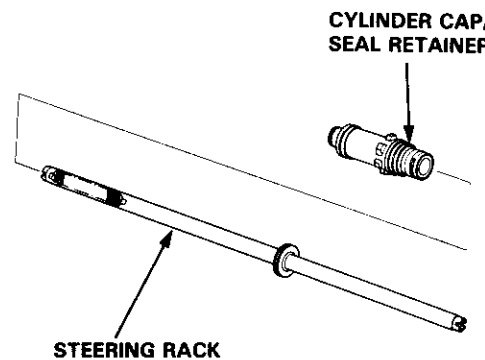

(cont'd)

Steering Gearbox

Overhaul (cont'd)

24. Remove the O-ring and snap ring from the seal retainer, then remove the cylinder cap from the seal retainer.

25. Remove the O-rings from the cylinder cap.

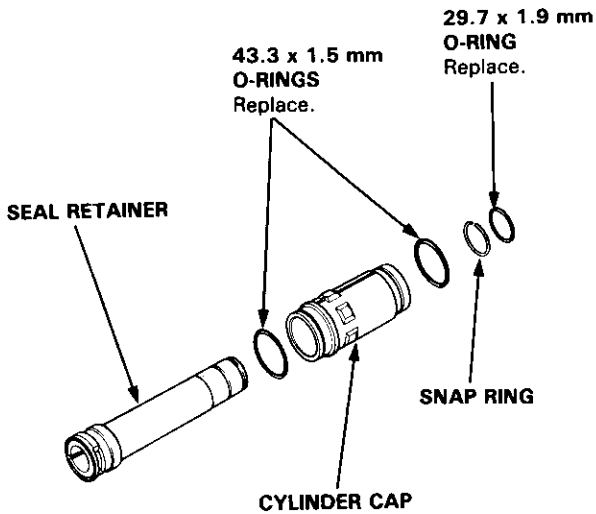

26. Remove the bushing stopper ring from the seal retainer.

27. Remove the cylinder end seal and rack bushing B.

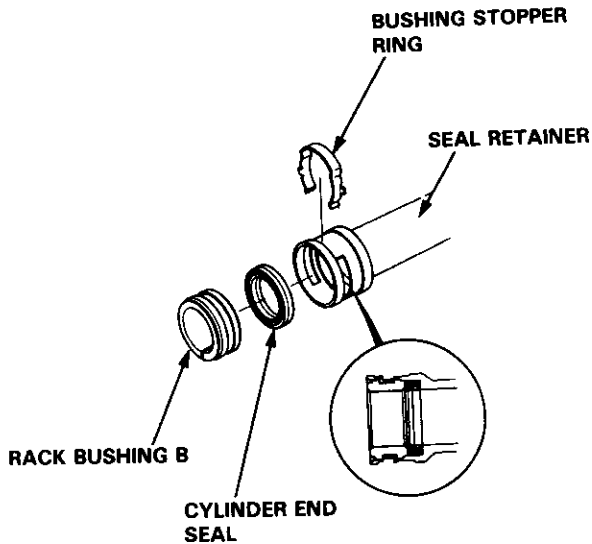

28. Carefully pry the piston seal ring and O-ring off the piston.

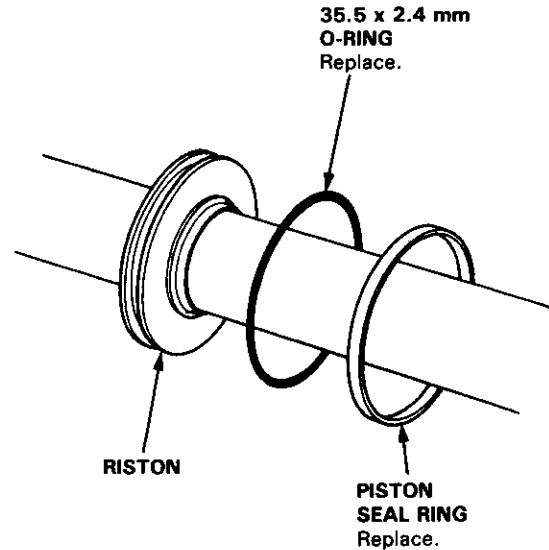

NOTE: Before reassembling any parts, inspect them as described on page 17-117 and make sure they are clean. Replace worn or damaged parts.



29. Install a new O-ring on the piston with its narrow edge facing out.

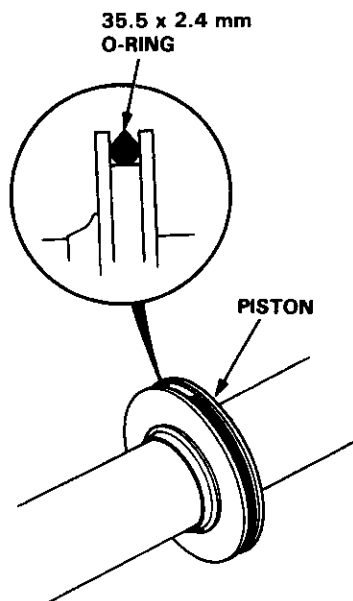

30. Coat the piston seal ring guide with power steering fluid, then slide it onto the rack, big end first.
31. Position the new piston seal ring on the special tool, slide it down onto the big end of the tool, then pull it off into the piston groove on top of the O-ring.

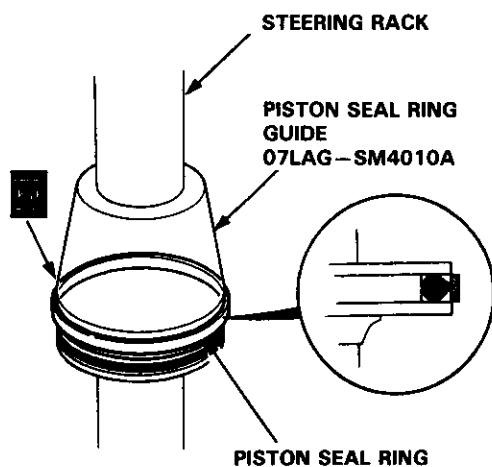

32. Coat the piston seal ring and inside of the special tool with power steering fluid.

33. Carefully slide the tool onto the rack and over the piston seal ring, then rotate the tool as you move it up and down to seat the piston seal ring.

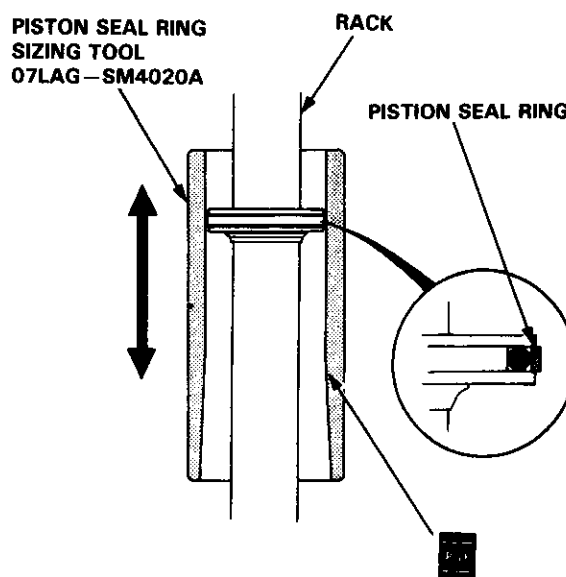

34. Coat new O-rings with power steering fluid and install them on the cylinder cap.

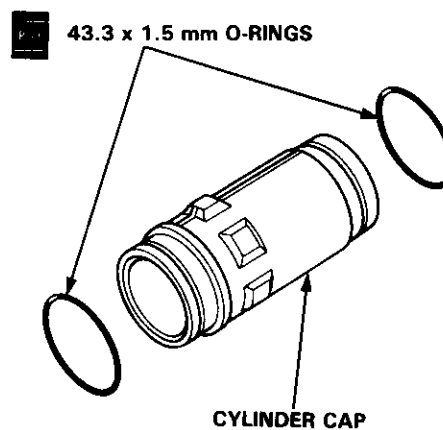

(cont'd)

Steering Gearbox

Overhaul (cont'd)

- Slide the cylinder cap onto the seal retainer.
- Install the snap ring on the seal retainer and coat new O-ring with power steering fluid and install it on the seal retainer.

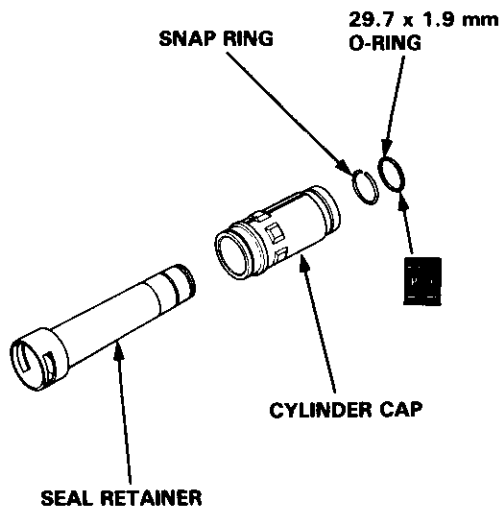

- Grease the sliding surface of the rack bushing B, and install the bushing on the steering rack.

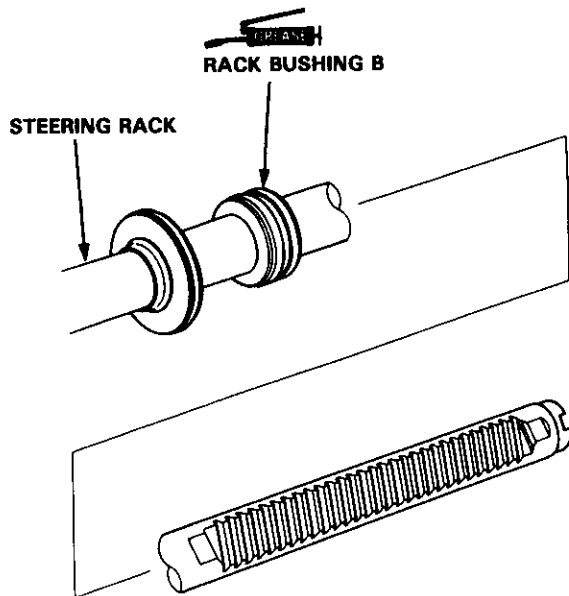

- Grease the sliding surfaces of the new cylinder end seal and the special tool, then place the seal on the special tool with its grooved side facing opposite the slider.

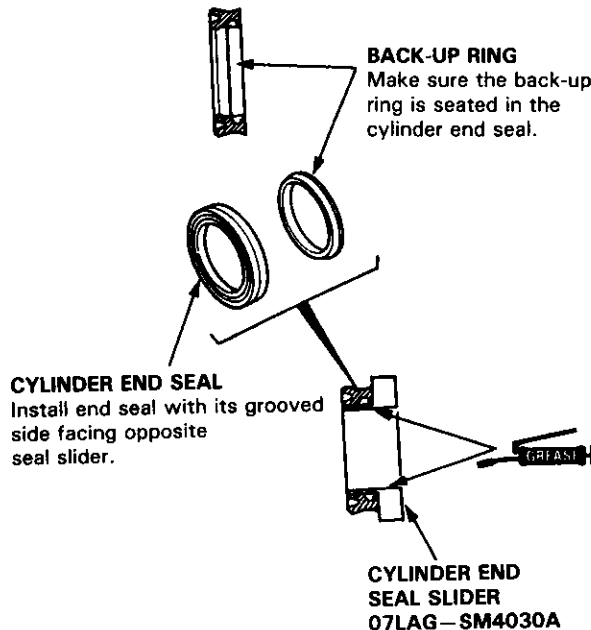

- Install the special tool and cylinder end seal.

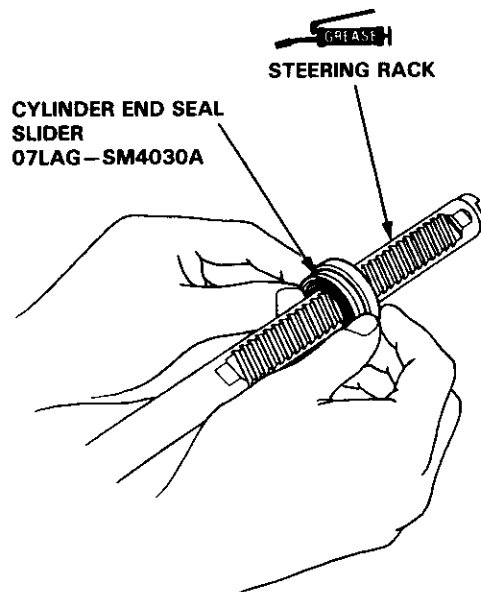



40. Separate the cylinder end seal from the special tool, then remove the special tool from the rack.

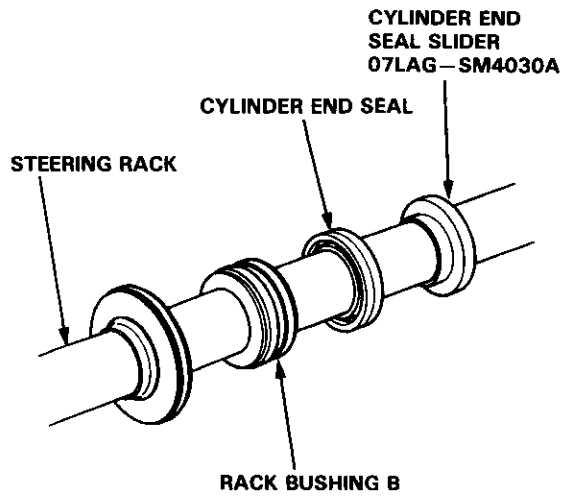

41. Fit the seal retainer on the steering rack.

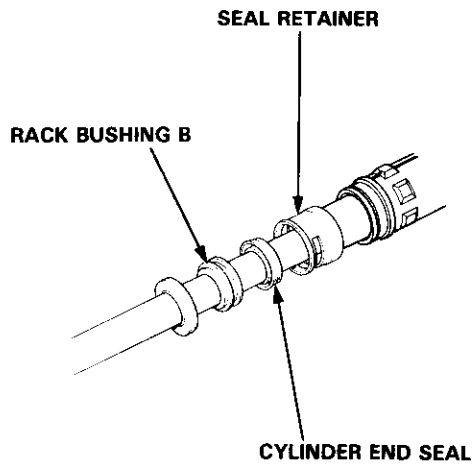

42. Push the rack bushing B toward the seal retainer by hand until the cylinder end seal is seated in the retainer. Fit the bushing stopper ring in the groove of the seal retainer securely. Then grease the steering rack.

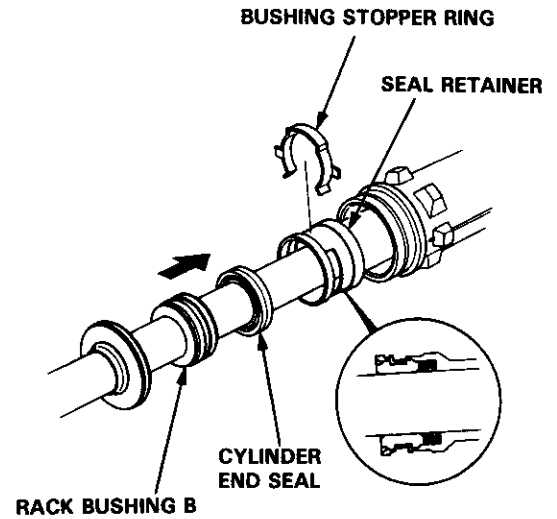

43. Install the retainer washer on the gear housing.

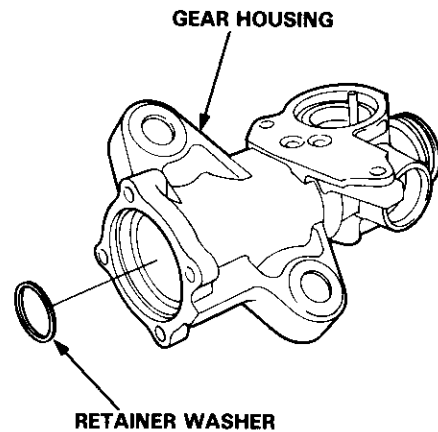

(cont'd)

Steering Gearbox

Overhaul (cont'd)

44. Place the gear housing on the work bench and insert the seal retainer and steering rack into the gear housing.
45. Coat the inside surface of the cylinder with power steering fluid, slide it over the rack and into the gear housing; press it into the housing until it seats.

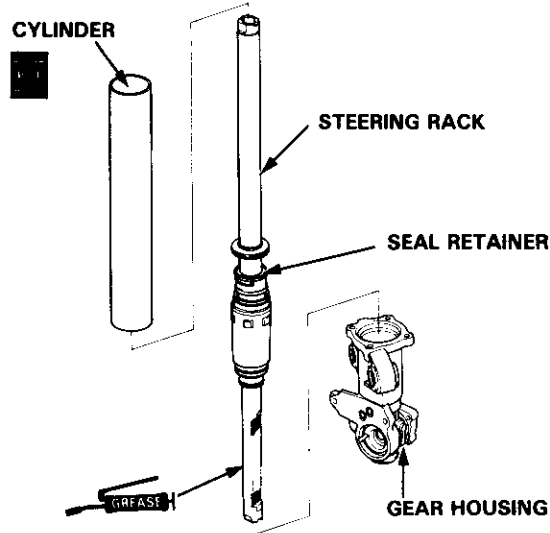

46. Install the cylinder spring over the rack, then coat the rack bushing A with grease and install it on the spring.
47. Wrap the end of the steering rack with vinyl tape. Coat the tape with grease.

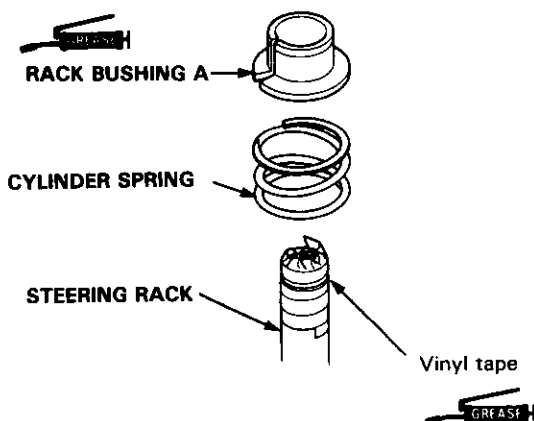

48. Coat the inside surface of the cylinder with power steering fluid and install the cylinder end seal with its grooved side facing out.

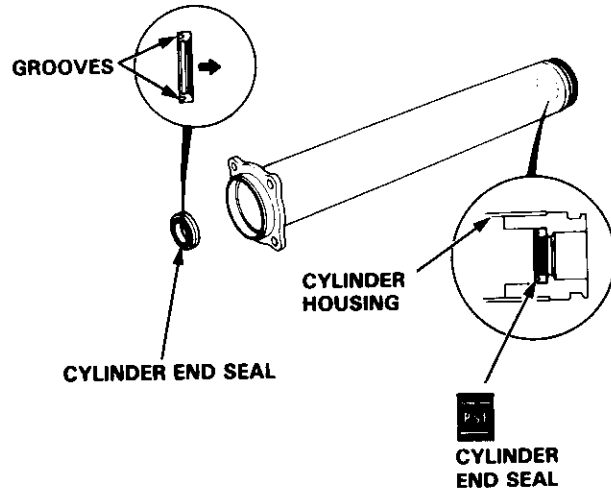

49. Coat the new O-ring with grease, then install the O-ring and back-up ring into the gear housing.
50. Carefully position the cylinder on the gear housing and loosely install with four cylinder bolts.

CAUTION: Be careful not to damage the end seal in the cylinder housing.

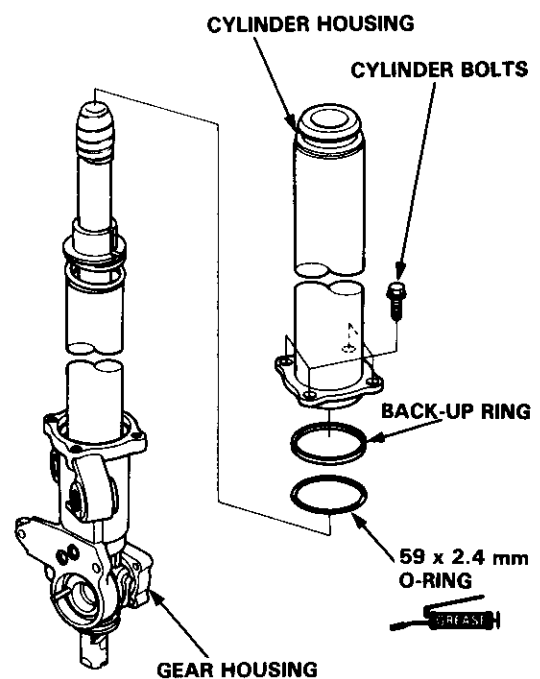



51. Remove the vinyl tape from the steering rack.

52. Tighten the four cylinder bolts.

NOTE: Before tightening the bolts, make sure the mating surfaces of the cylinder and gear housing fit properly by pushing them together; hold them together while tightening the bolts.

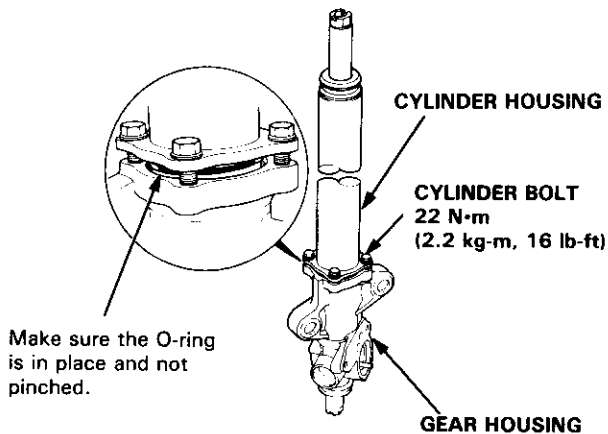

53. Insert the steering rack into the cylinder housing, being careful not to damage the steering rack sliding surface.

54. Install the pinion in the pinion holder. Install the circlip securely in the pinion holder groove.

NOTE: Install the circlip with its tapered side facing out.

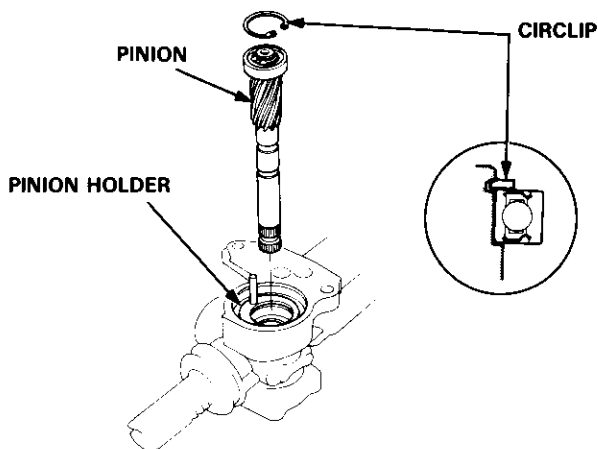

55. Grease the sealing lip of the steering pinion seal, and install it on the gear housing cap.

56. Wrap the spline area of the steering pinion with vinyl tape and grease the surface of the tape.

57. Grease the new O-ring and install it in the gear housing.

58. Slide the gear housing cap over the steering pinion, being careful not to damage sealing lip or dislodge the spring of the steering pinion seal.

59. Remove the vinyl tape.

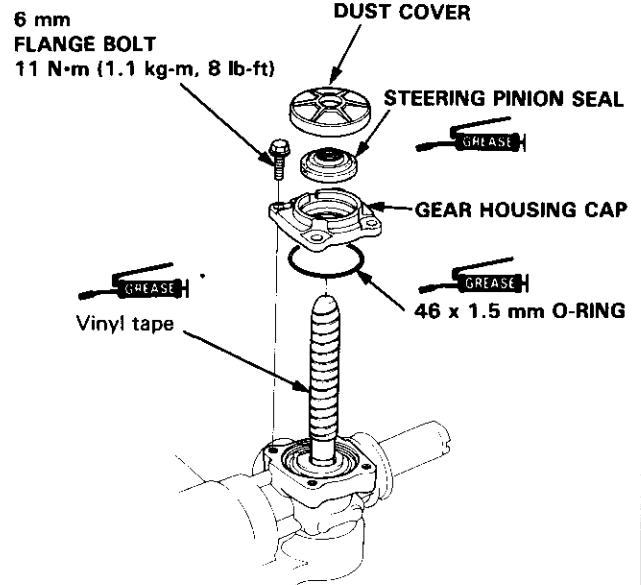

60. Screw each rack end into the steering rack while holding the lock washer so its tabs are in the slots in the steering rack.

61. Hold the steering rack with a wrench and tighten the rack end to 65 N·m (6.5 kg·m, 47 lb·ft).

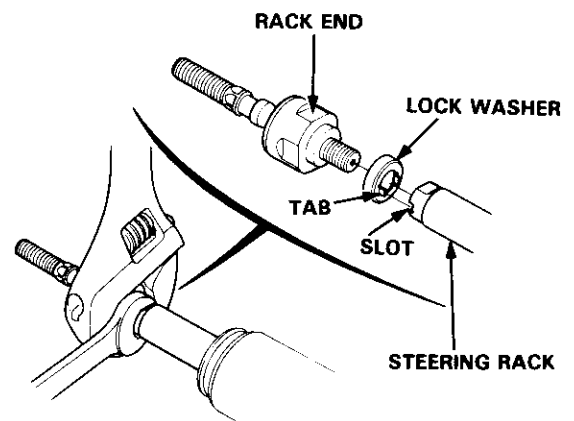

(cont'd)

Steering Gearbox

Overhaul (cont'd)

62. After tightening the rack end, stake the four sections of lock washer with a drift.

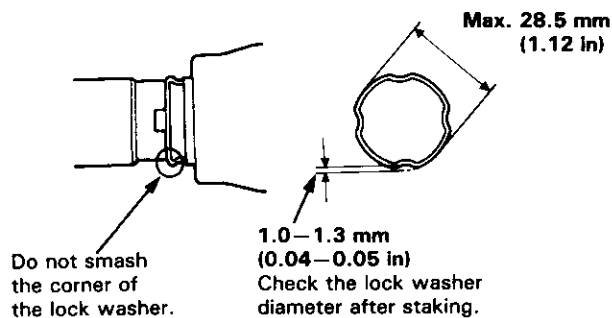
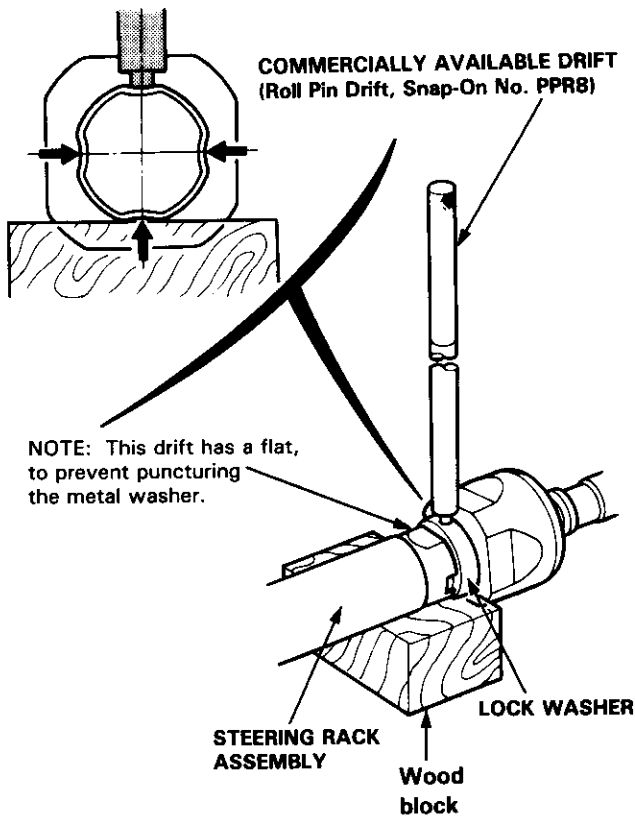

63. Apply grease to the circumference of the rack end.

64. Coat the tie-rod groove and inside of the boot with silicone grease.

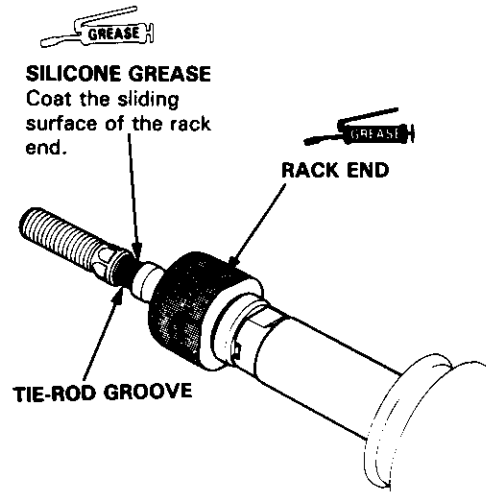

65. Install the boots on the rack end with the tube clamps.

NOTE: Check that the boot joint piece (i.e. air hose joint) is not clogged with grease.

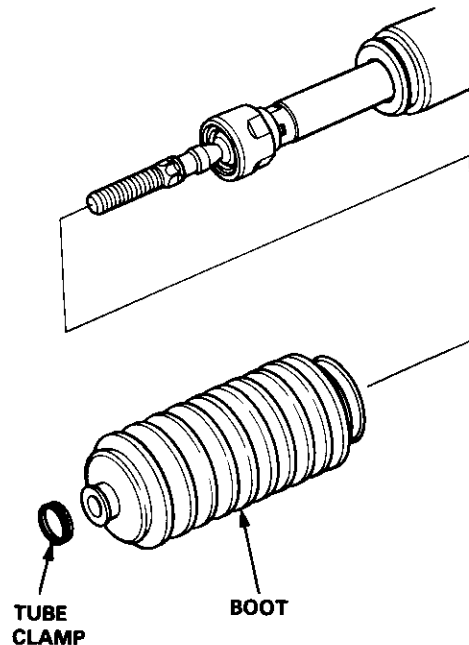



66. Install the right and left tie-rod ends.

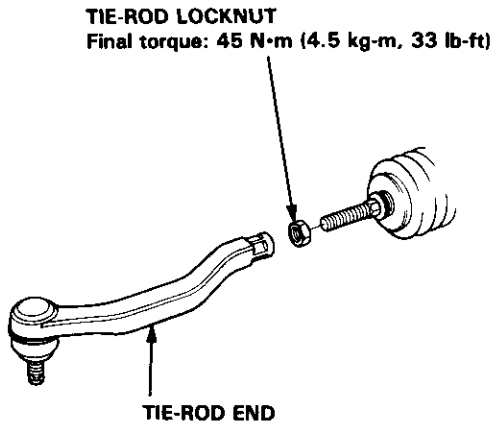

67. Grease a new O-ring and install it in the groove in the rack guide screw.

68. Coat the rack guide sliding surface with grease..

69. Install the rack guide, spring and rack guide screw on the gear housing.

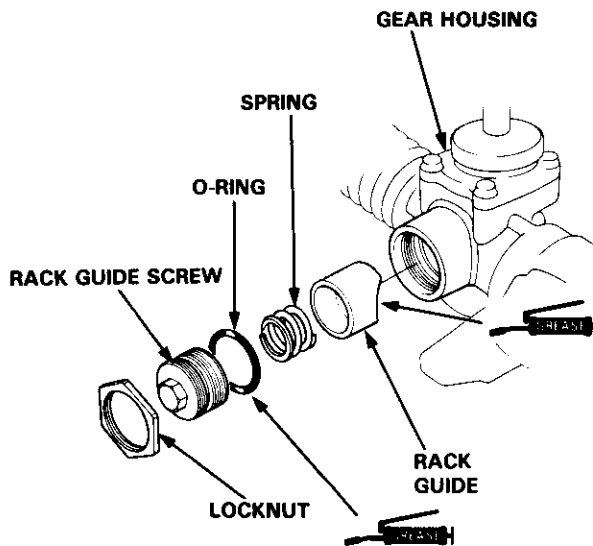

70. Adjust the rack guide at the center of the rack stroke.

71. Tighten the rack guide screw until it compresses the spring and seats against the rack guide, then loosen it.

72. Retighten it to 4 N·m (0.4 kg-m, 2.9 lb-ft), back it off about 20^{+5}_0 then install the locknut on the rack guide screw.

73. Tighten the locknut with the special tool to about 25 N·m (2.5 kg-m, 18 lb-ft) while holding the rack guide screw.

LOCKNUT WRENCH, 43 mm
07MAA-SL0020A **RACK GUIDE SCREW**
Hold.

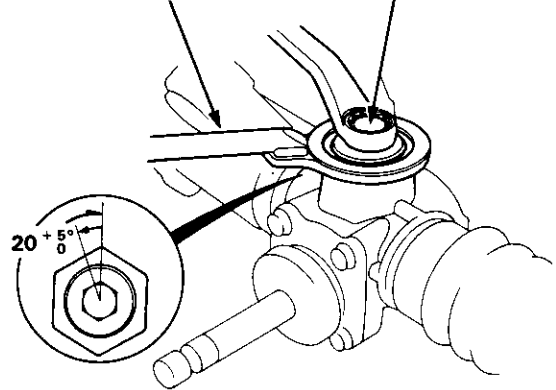

4WS:

74. Install the locknut on the front sub steering angle sensor.

75. Grease a new O-ring and install it in the groove in the front sub steering angle sensor. Install the rack guide screw.

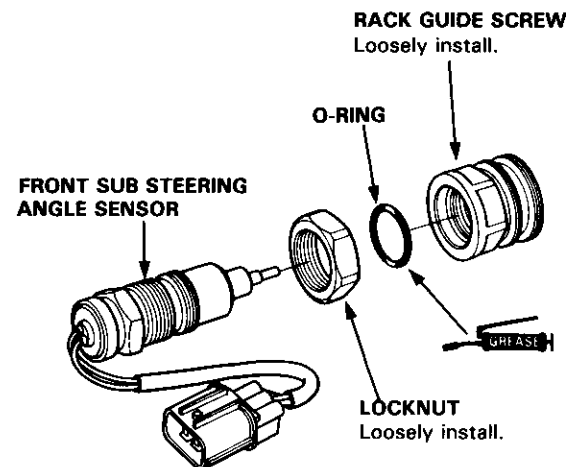

(cont'd)

Steering Gearbox

Overhaul (cont'd)

76. Coat the rack guide sliding surface with grease.
77. Install the rack guide, spring, O-ring and the rack guide screw/front sub steering angle sensor on the gear housing. Then adjust the rack guide at the center of the rack stroke.

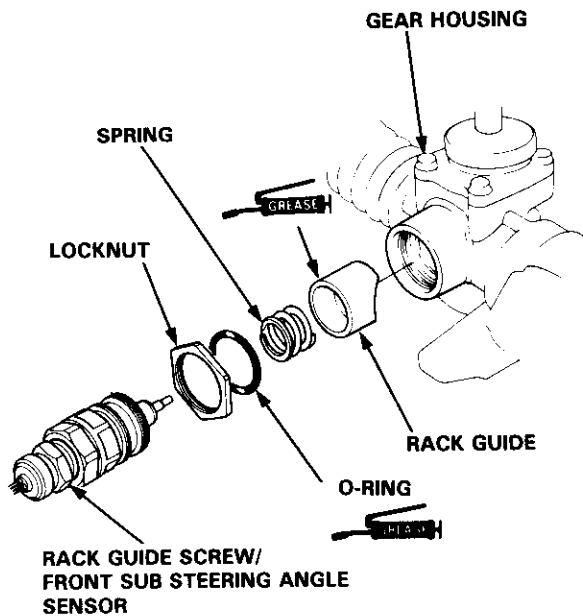

78. Tighten the rack guide screw until it compresses the spring and seats against the rack guide, then loosen it.
79. Retighten it to 4 N·m (0.4 kg-m, 3 lb-ft), back it off about 20^{+5}_0 and install the locknut on the rack guide screw with the special tool.
80. Tighten the locknut to with the special tool about 25 N·m (2.5 kg-m, 18 lb-ft) while holding the guide screw.

LOCKNUT WRENCH, 43 mm
07MAA-SL0020A

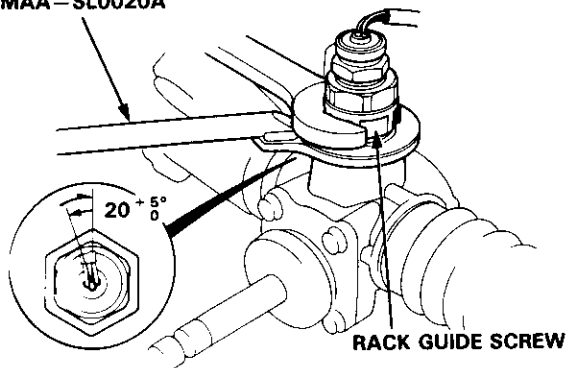

81. Coat the 9.8 x 1.9 mm O-rings with power steering fluid, and install them together with the orifices.
82. Coat the 45.5 x 2 mm O-ring and pinion holder pin with grease, then install it in the valve body unit.
83. Install the valve body unit on the gear housing with the two 8 mm bolts.

CAUTION:

- When installing, be careful not to hit the pinion holder pin.
- Make sure the O-rings are in place and not pinched.

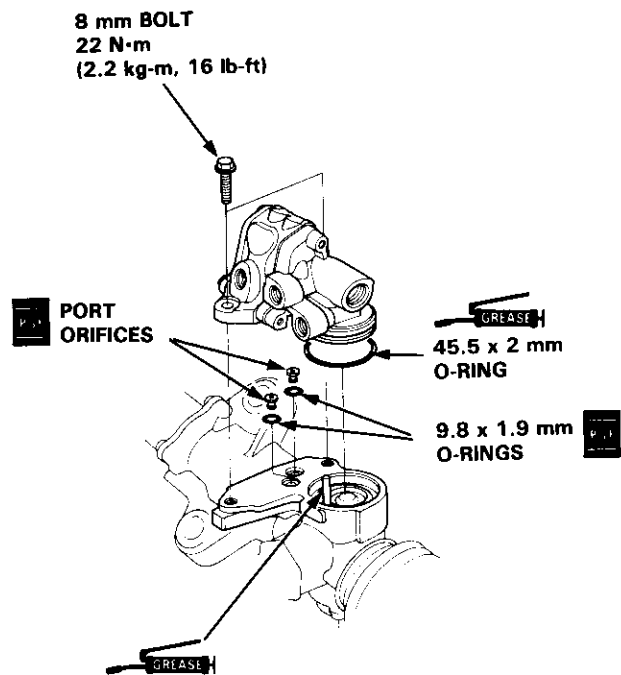



NOTE: Install the boot band with the rack in the straight ahead position (i.e. right and left tie-rods are equal in length).

84. Install the boot band so that the locking tabs of the band (stake points) are in the range shown below. (Locking tabs should face up and slightly forward.)

85. Install new boot bands on the boot and bend both sets of locking tabs.

86. Lightly tap on the doubled-over portions to reduce their height.

CAUTION:

- Stake the band locking tabs firmly.
- When staking, be careful not to damage the boot.

87. Install the air hose clip as shown.

88. Install the band cushion and air hose band; position the band as shown then tighten it. Install the air hose.

89. After assembling, slide the rack right and left to be certain that the boots are not deformed or twisted.

NOTE: After installation, perform the electrical check on the 4WS system (see page 17-146).

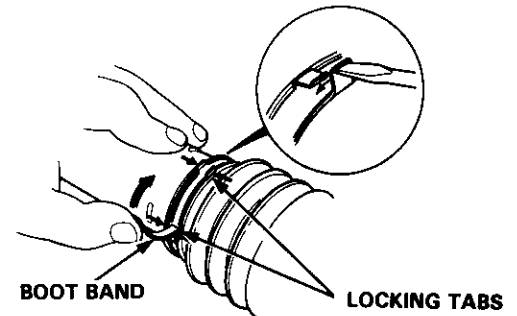

AIR HOSE CLIP
(Viewed from the right side)

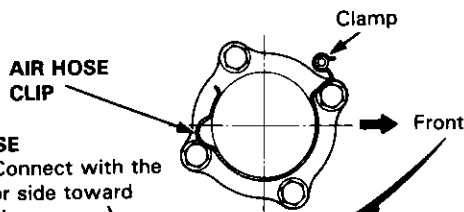

AIR HOSE BAND
(Viewed from the right side)

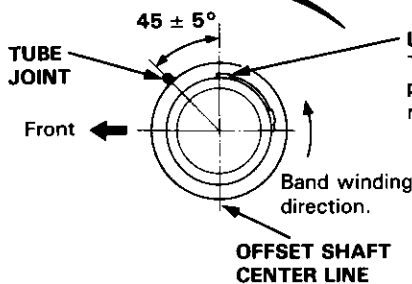
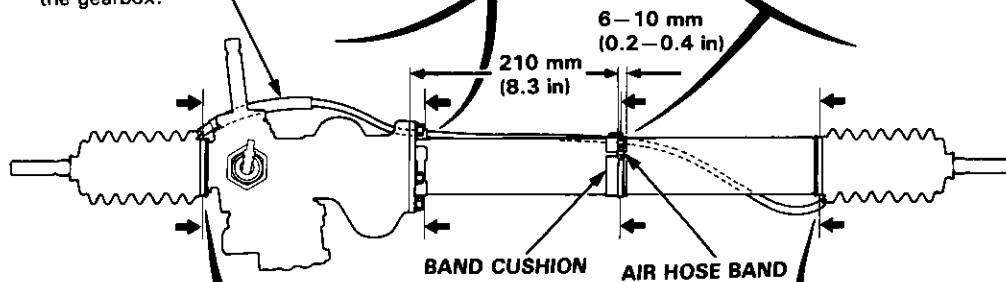
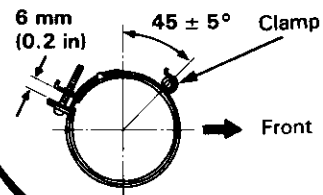

LEFT BOOT BAND
(Viewed from the left side)

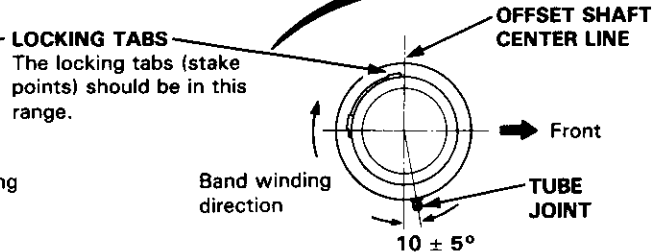

RIGHT BOOT BAND
(Viewed from the right side)

Steering Gearbox

Installation

1. Slide the rack all the way to the right.
2. Pass the right side of the steering gearbox assembly above and through the right side of the rear beam.
3. Hold the steering gearbox assembly and slide the rack all the way to the right.
4. Raise the left side of the steering gearbox assembly above and through the left side of the rear beam.

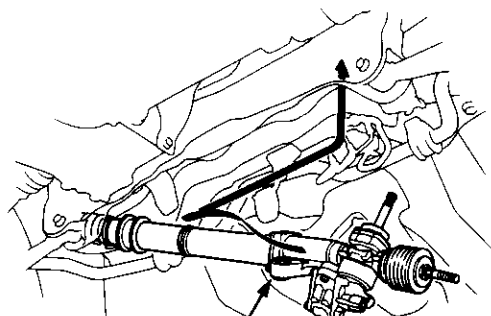

STEERING GEARBOX ASSEMBLY

5. Loosely install the left and right mounting brackets with the six mounting bolts.
6. Tighten the mounting bolts on the left mounting bracket first, then tighten the mounting bolts on the right mounting brackets.

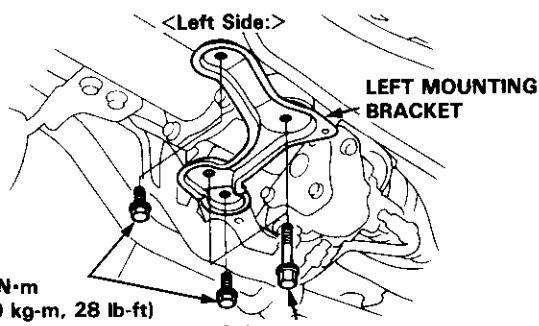

39 N·m
(3.9 kg-m, 28 lb-ft)

<Right Side:> 44 N·m
(4.4 kg-m, 32 lb-ft)

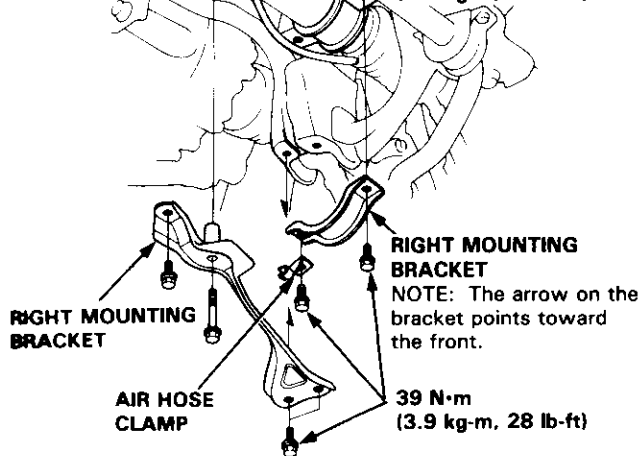

RIGHT MOUNTING BRACKET

AIR HOSE CLAMP

RIGHT MOUNTING BRACKET

NOTE: The arrow on the bracket points toward the front.

39 N·m
(3.9 kg-m, 28 lb-ft)

7. Position the steering rack center of its strokes.
8. Make sure that the cable reel of the driver's airbag system is centered as follows:
 - Turn the steering wheel left approx. 150 degrees, to check the cable reel position with indicator.
 - If the cable reel is centered, the yellow gear tooth lines up with the alignment mark on the cover.
 - Return the steering wheel right approx. 150 degrees to position the steering wheel to the straight ahead position.

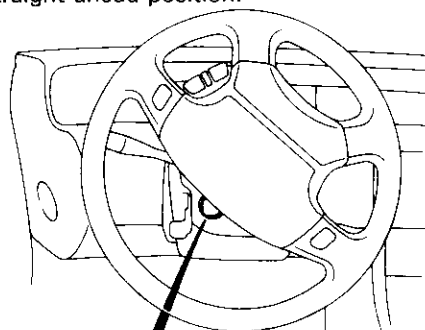

YELLOW GEAR TOOTH

ALIGNMENT MARK

9. Slip the lower of the steering joint onto the pinion shaft (line up the bolt hole with the groove around the shaft) and loosely install the steering joint bolt.

NOTE:

- Connect the steering shaft and pinion when the cable reel and steering rack are centered.
- Be sure that the steering joint bolt is securely in the groove in the pinion shaft.

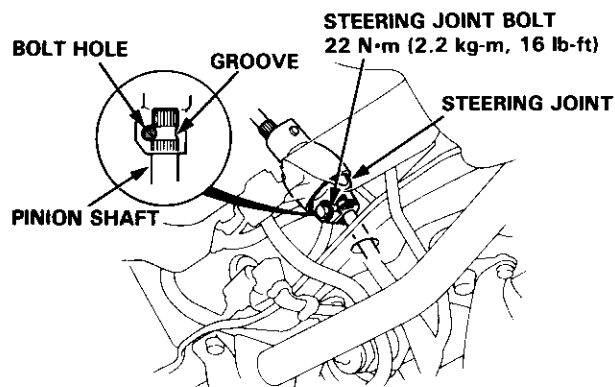

BOLT HOLE

GROOVE

STEERING JOINT BOLT

22 N·m (2.2 kg-m, 16 lb-ft)

STEERING JOINT

PINION SHAFT



10. Connect the four lines to the valve body unit, using flare nut wrenches.

- A: To oil cooler: 17 mm wrench
29 N·m (2.9 kg-m, 21 lb-ft)
- B: To power steering speed sensor:
12 mm wrench
13 N·m (1.3 kg-m, 9 lb-ft)
- C: To reservoir: 12 mm wrench
13 N·m (1.3 kg-m, 9 lb-ft)
- D: From pump: 14 mm wrench
38 N·m (3.8 kg-m, 28 lb-ft)

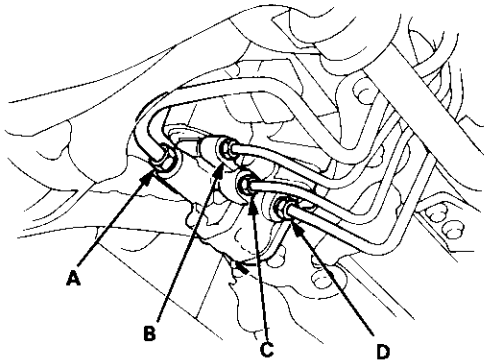

11. Reconnect the connector and secure the sensor wire harness with the clamp and install the cover.

NOTE:

- Be sure the sensor wire harness does not interfere with the stabilizer or other moving parts.
- Be certain that the sensor wire harness is not twisted before connecting it.

12. Set the cover on the front sub steering angle sensor. Secure the sensor wire harness and cover with a new wire tie.

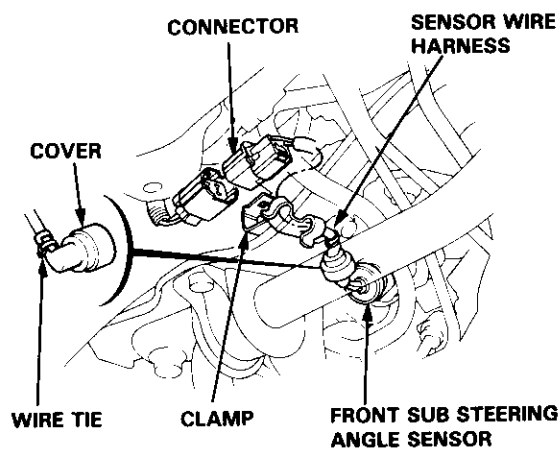

NOTE: After rack guide adjustment, perform the electrical check on the 4WS system (see page 17-146).

13. Fill the reservoir with power steering fluid and bleed air from the system by turning the steering wheel from lock to lock several times with the engine warm (see page 17-77).

14. Make sure there are no fluid leaks, then install the gearbox shield.

Recheck the fluid level in the reservoir.

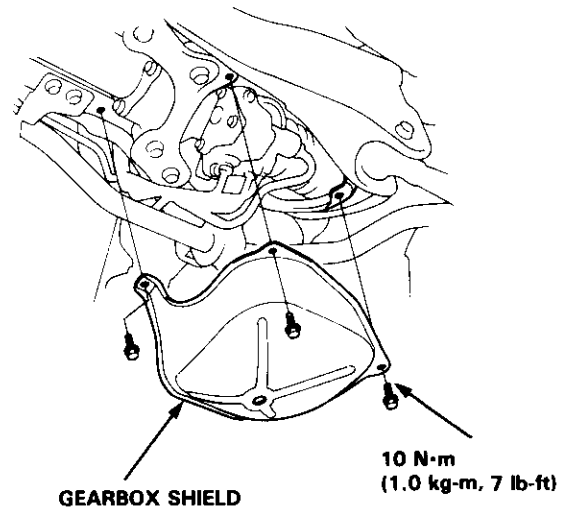

15. Install the center beam.

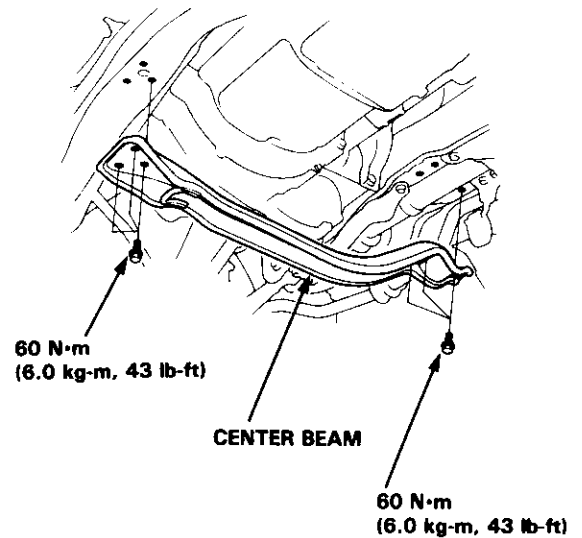

(cont'd)

Steering Gearbox

Installation (cont'd)

16. Automatic transmission model only.

- Connect the shift cable end to the shift control shaft, and install the cable holder.

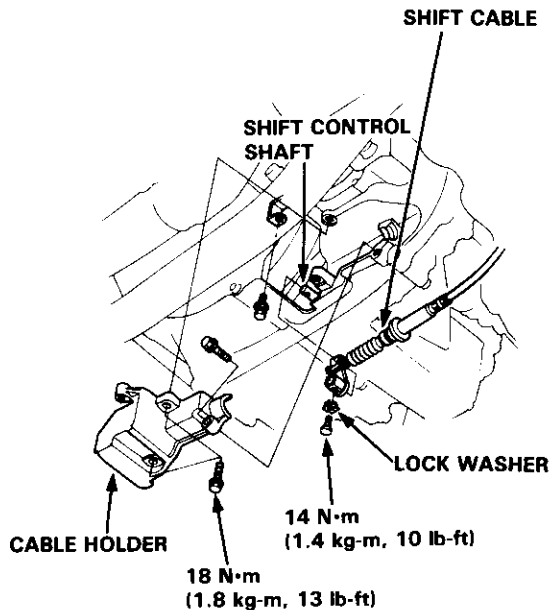

17. Install the exhaust pipe A with a new gasket, then tighten the new self-locking nuts. Connect the heated oxygen sensor connector (H23A1 and H22A1 engine).

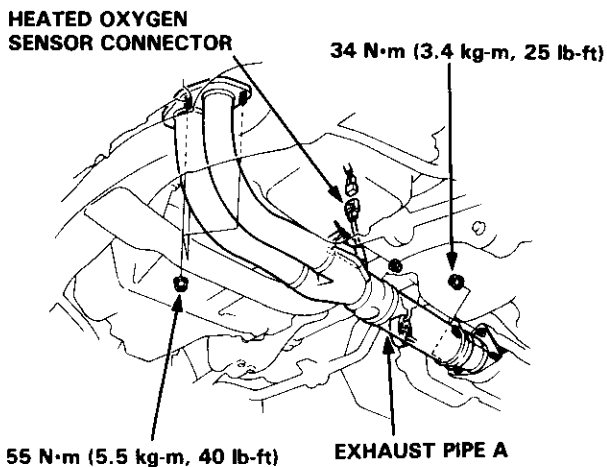

18. Reconnect the tie-rod ends to the steering knuckles, tighten the castle nut to the specified torque, and install new cotter pins.

CAUTION: Torque the castle nut to the lower torque specification, then tighten it only far enough to align the slot with the pin hole. Do not align the nut by loosening.

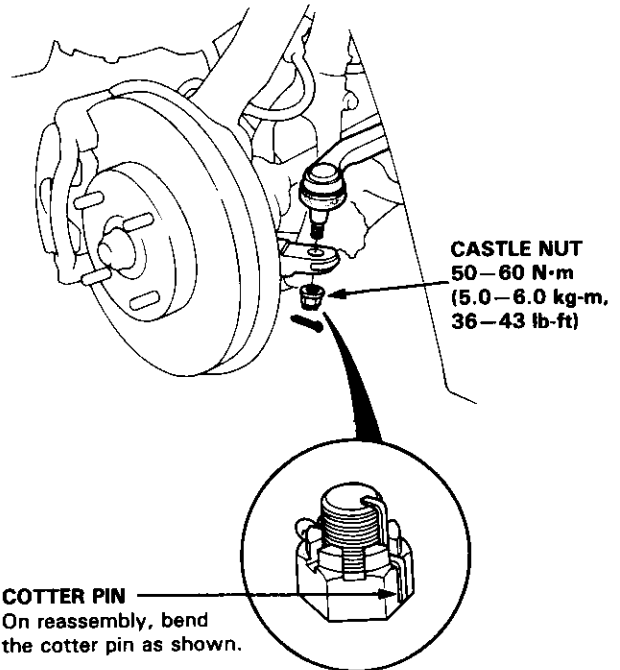

19. Adjust the front toe (see section 18).

NOTE: If the steering wheel and rack are not aligned centered, reposition the serrations at lower end of the steering joint.

20. Fill the system:

- Fill the reservoir with new Honda Power Steering Fluid-V (see page 17-77).

21. After installation, perform the following checks.

- Start the engine and let it run at idle, then turn the steering wheel from lock-to-lock several times to bleed air from the system (see page 17-77).
- Check the fluid again, and add more if necessary.
- Check the gearbox for leaks.
- Check the front toe (see section 18).
- Check the steering wheel spoke angle.
- Check the 4WS system (4WS only).



Rear Steering Actuator

Illustrated Index

CAUTION:

- Do not strike the rack end and shaft screw.
- Use the special tool when removing the rear steering actuator. The special tool should remain installed except when the actuator is inspected for function, etc.
- Do not try to disassemble the rear steering actuator. If the actuator is faulty, replace it as an assembly.
- When disassembling and servicing, do not let dust, dirt, and foreign materials enter the rear steering actuator.
- When either the rear sub steering angle sensor or the rear main steering angle sensor are removed, perform inspection and adjustment of the rear sub steering angle sensor after installing the rear steering actuator.
- Lock the shaft screw using the rear steering lock pin special tool before removal/installation and disassembly/reassembly of the rear steering actuator assembly.

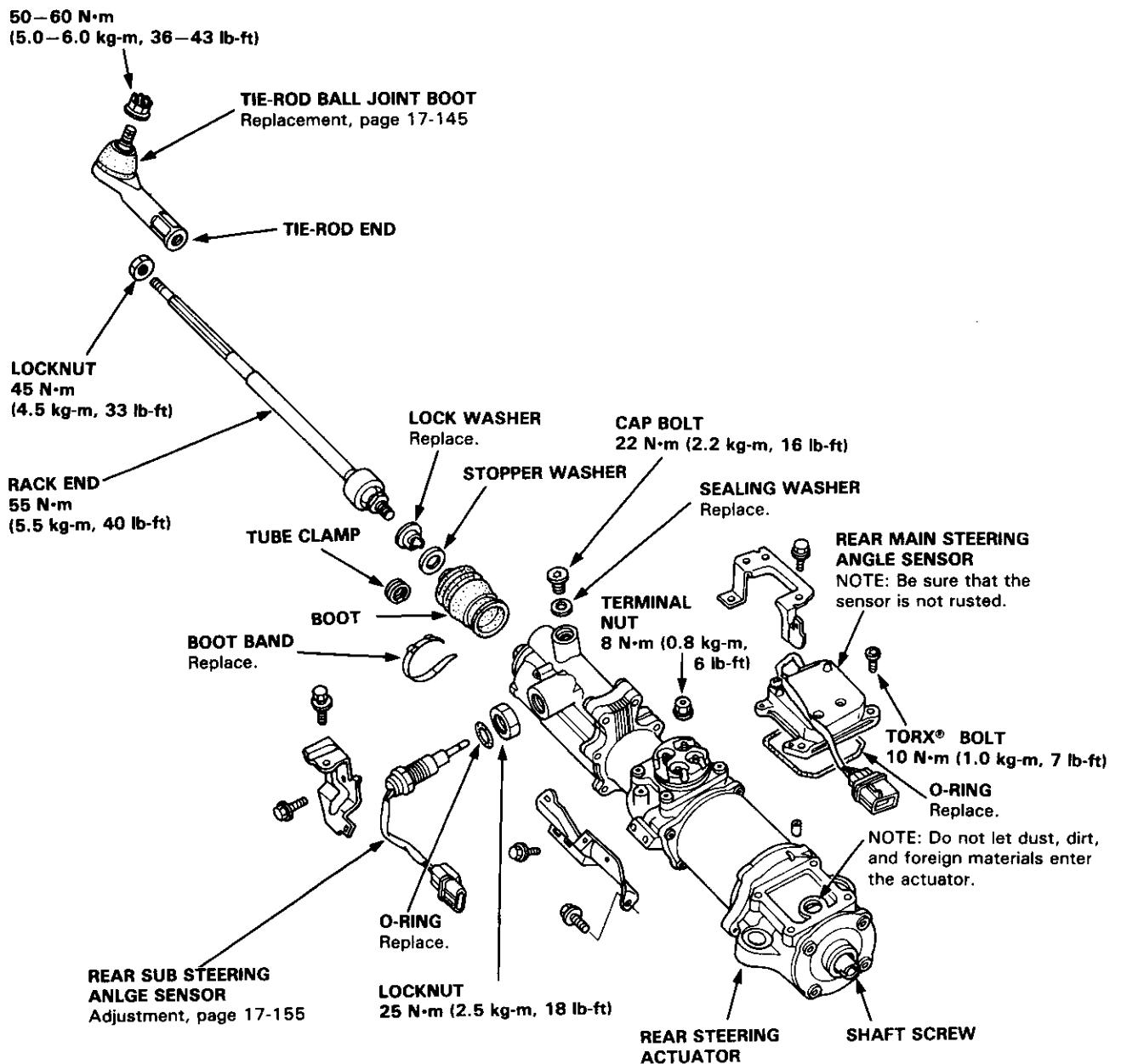

Rear Steering Actuator

Removal

1. Raise the rear of car and support on safety stands in the proper locations (see section 1).

NOTE: When the engine is OFF, the shaft screw of the rear steering actuator is held in the neutral position (straight ahead driving position) by the return spring tension.

CAUTION: Do not start the engine with the rear steering lock pin set in the rear steering actuator. If the steering wheel is turned with the engine running, the rear steering actuator will operate, damaging the rear steering actuator.

2. Remove the cotter pin from the castel nut and remove the nut.
3. Install a 12 mm hex nut on the ball joint. Be sure that the 12 mm hex nut is flush with the ball joint pin end, or the threaded section of the ball joint pin might be damaged by the ball joint remover.

NOTE: Remove the ball joint using the Ball Joint Remover. Refer to page 18-13 for how to use the ball joint remover.

4. Separate the tie-rod ball joint and knuckle using the special tool.

CAUTION: Avoid damaging the ball joint boot.

12 mm HEX NUT

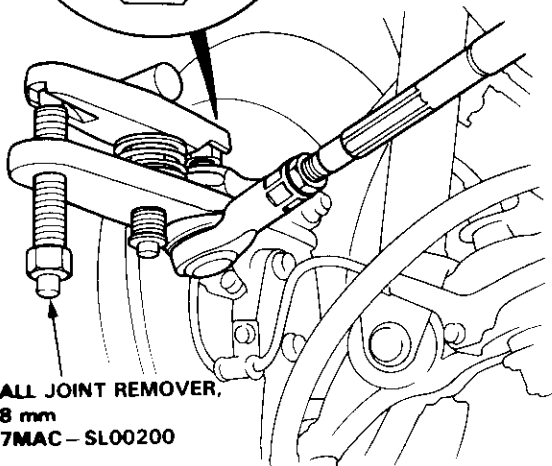
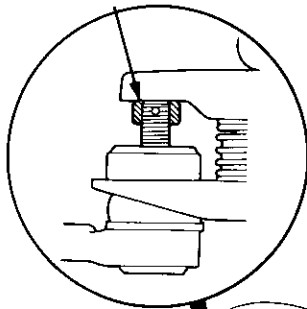

BALL JOINT REMOVER,
28 mm
07MAC - SL00200

5. Remove the rear steering actuator cover.

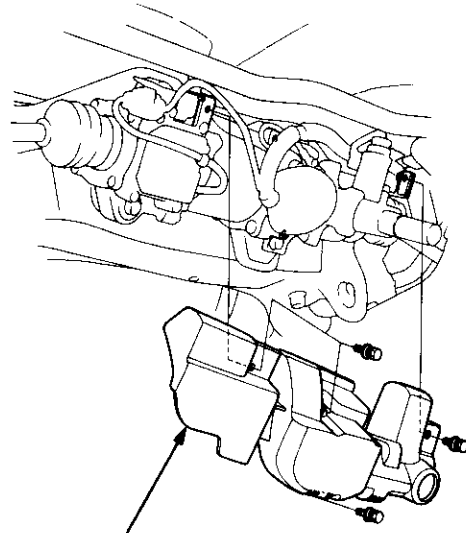

REAR STEERING ACTUATOR COVER

6. Disconnect the ground cable connectors and terminals from the rear steering actuator.

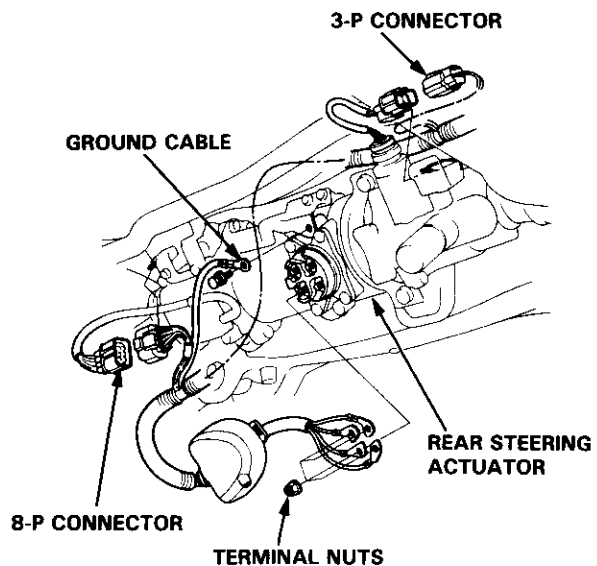

NOTE: Do not contaminate the terminal bolt and nut with grease. Clean them if necessary.



7. Remove the rear steering actuator by removing the four mounting bolts and bracket.

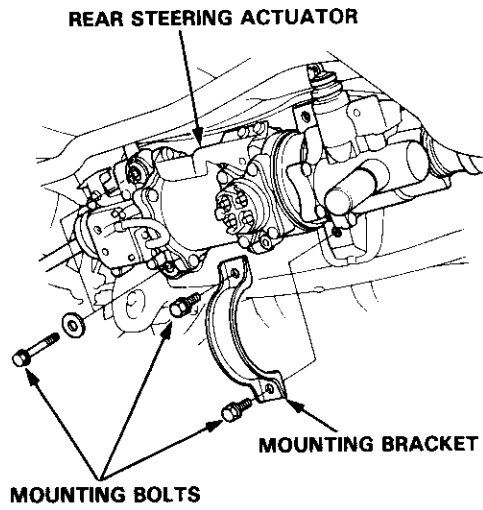

Rear Steering Actuator

Disassembly

1. Remove the tie-rod ends.

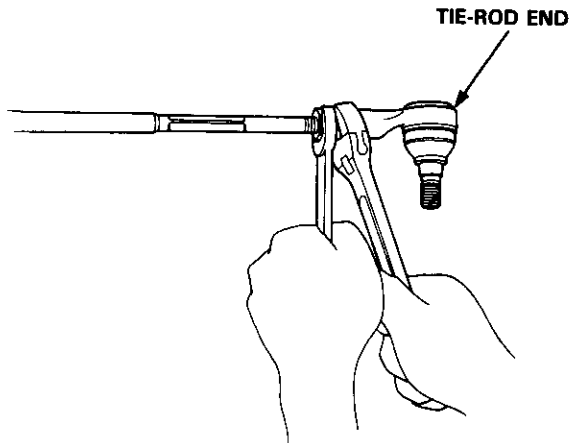

2. Remove the boot bands and tube clamps. Pull the boots away from the ends of the rack end.

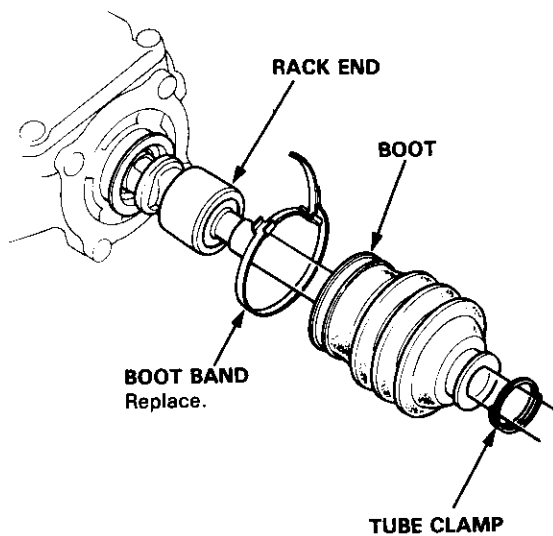

3. Using a soft hammer, drive in the special tool between the actuator housing and stopper washer with the flat side of the special tool toward the housing.

4. Straighten the tie-rod lock washer.

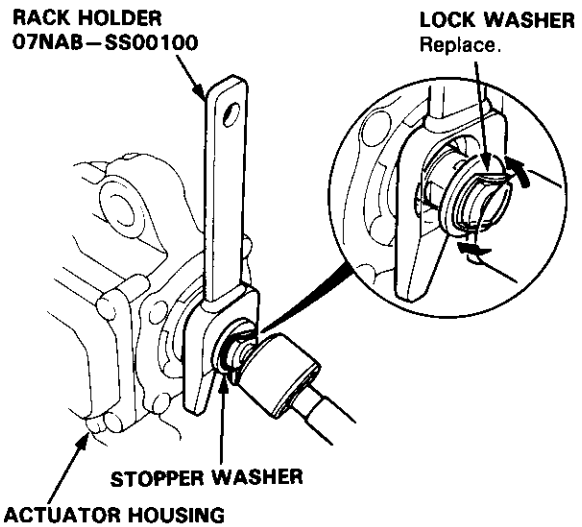

5. Hold the shaft screw end with the special tool and unscrew the rack end with a wrench.

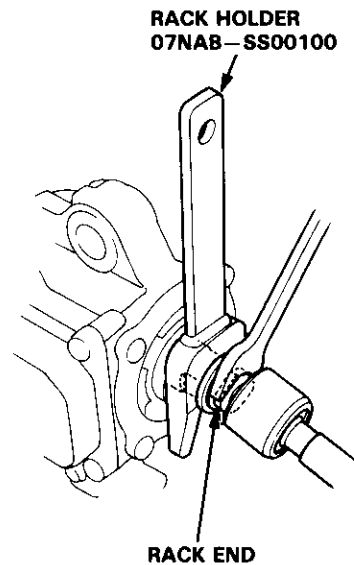

6. Remove the special tool.



7. Remove the rear sub steering angle sensor from the actuator housing.

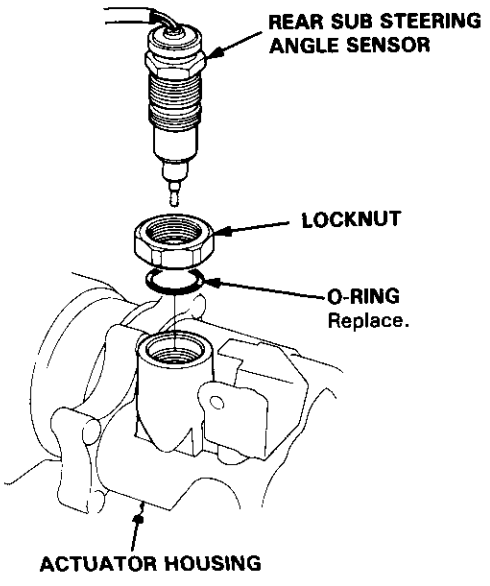

8. Remove the rear main steering angle sensor from the actuator housing.

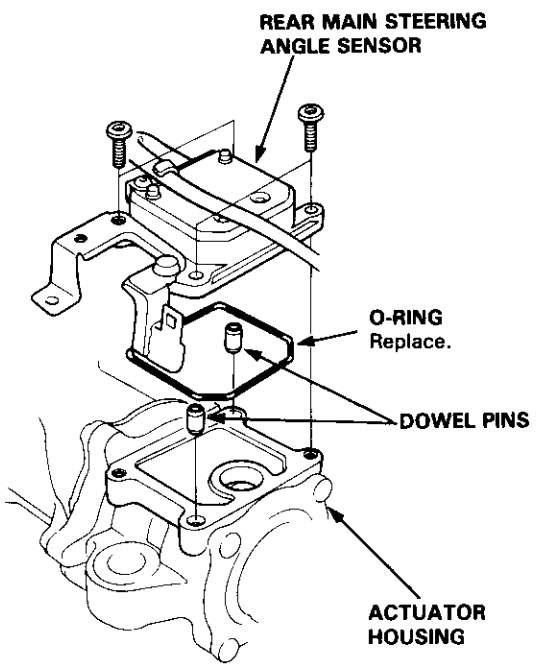

CAUTION: After disassembly, attach a piece of tape or equivalent material on each port and joint of the rear steering actuator to protect it from dust, dirt, and foreign materials.

Assembly

1. Install the locknut on the rear sub steering angle sensor, then grease a new O-ring and install it.
2. Screw the rear sub steering angle sensor into the actuator housing fully by hand, back it off about 1/2 turn, and loosely tighten the locknut.

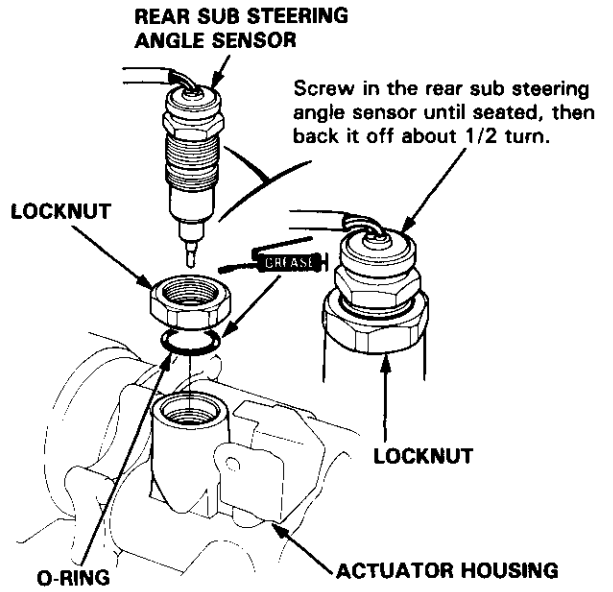

NOTE: Adjust the rear sub steering angle sensor (see page 17-155) after installing the rear steering actuator on the car.

(cont'd)

Rear Steering Actuator

Assembly (cont'd)

- Grease a new O-ring and install it in the rear main steering angle sensor, then install the rear main steering angle sensor.

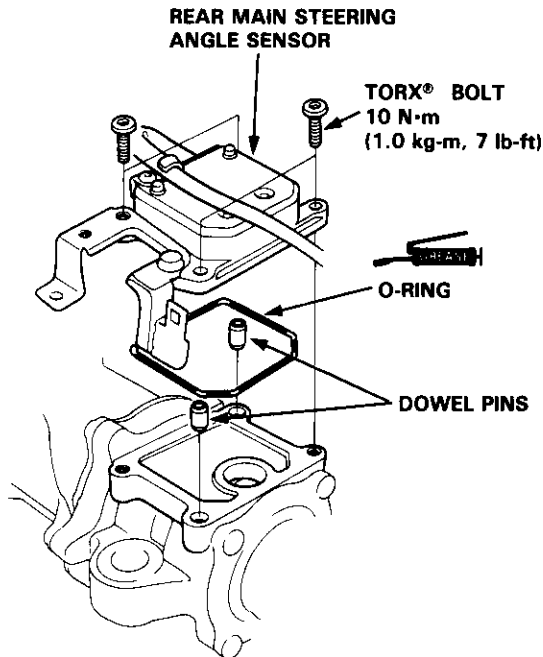

- Screw each rack end into the shaft screw while holding the lock washer so its tabs are in the slots the shaft screw end.

NOTE: Install the stopper washer with the chamfered side facing out.

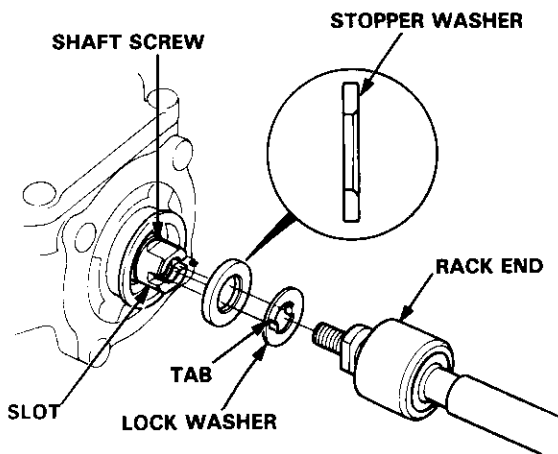

- Using a soft hammer, drive the special tool between the housing and stopper washer with the flat side of the special tool toward the housing.
- Tighten the rack end securely, then bend the lock washer back against the flat on the flange as shown.

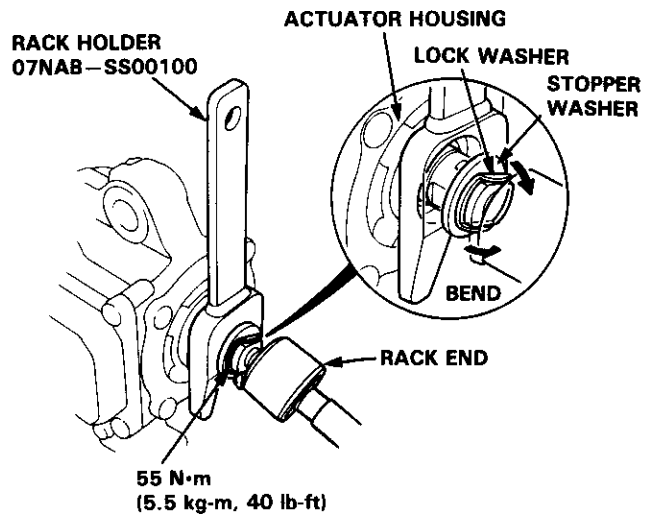

CAUTION:

- Take extreme care not to apply axial impact and rotational force on the shaft screw.
- Set the projection of the lock washer in the groove in the rack securely. After tightening the rack end, bend the tabs of the washer against the flats securely.

- Remove the special tool.
- Apply grease to the circumference of the rack end housing.
- Coat the rack end groove and inside of the boot with silicone grease.

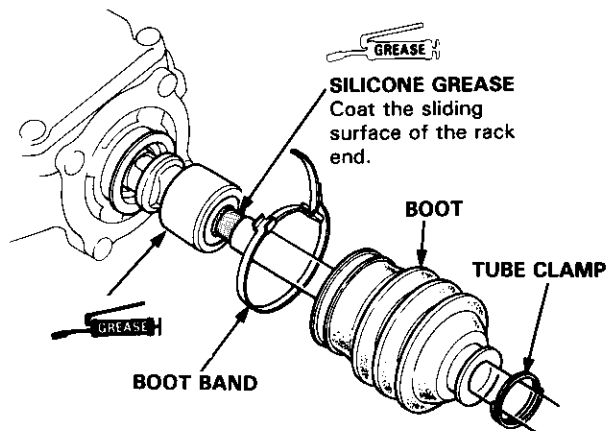



10. Install new boot bands.

- Install the boot band so that the locking tabs of the band (stake points) are in the range shown below.
(Tabs should face up and slightly forward.)

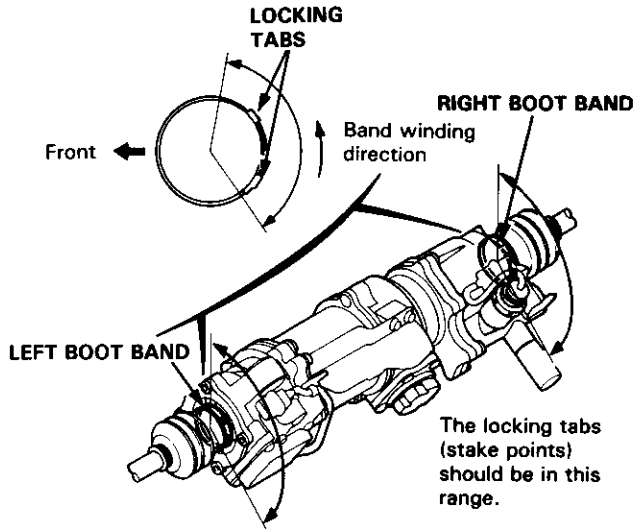

The locking tabs (stake points) should be in this range.

- Install new boot bands on the boot and bend both sets of locking tabs.
- Lightly tap on the doubled-over portions to reduce their height.

CAUTION:

- Stake the band locking tabs firmly.
- When staking, be careful not to damage the boot.

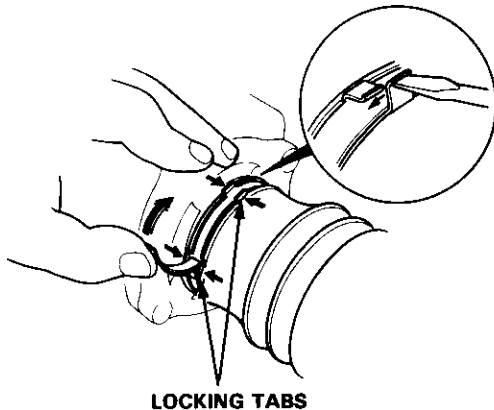

11. Install the right and left tie-rod ends on the right and left rack ends.

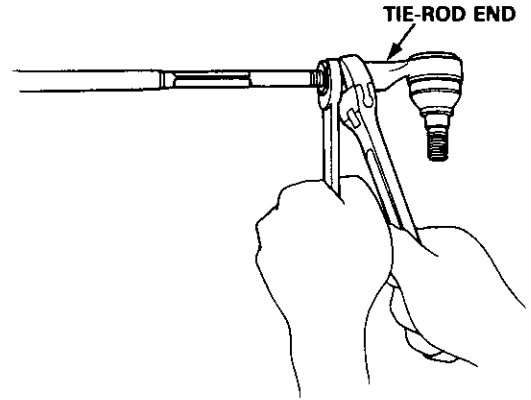

Rear Steering Actuator

Installation

1. Install the rear steering actuator with four mounting bolts and bracket.

NOTE: Install the bolts loosely first, then tighten them.

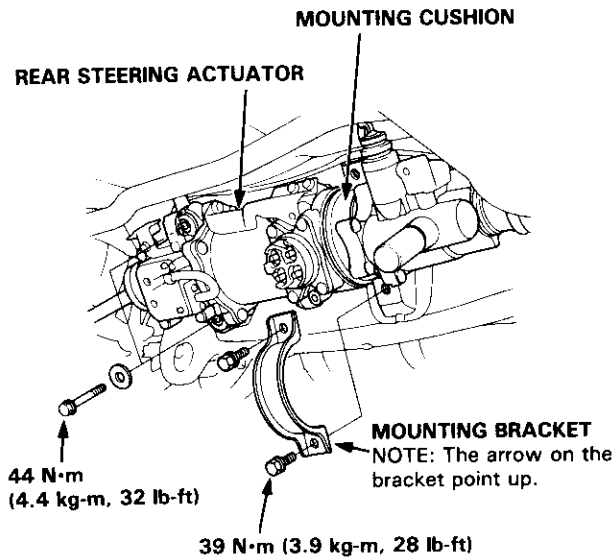

2. Reconnect the tie-rod ends to the rear steering knuckles, tighten the castle nut to the specified torque, and install new cotter pins.

CAUTION: Torque the castle nut to the lower torque specification, then tighten it only far enough to align the slot with the pin hole. Do not align the nut by loosening.

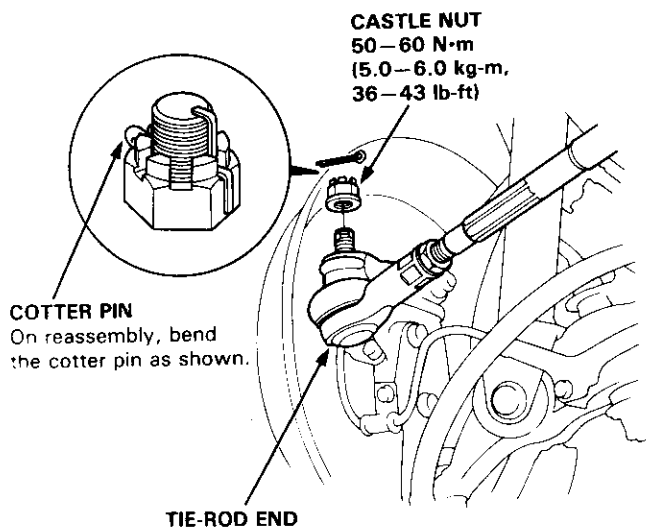

NOTE: Do not contaminate the terminal bolt and nut with grease. Clean them if necessary.

3. Connect the ground cable, connectors and terminals to the rear steering actuator.

NOTE: Be sure the wires are not caught or pinched by any parts.

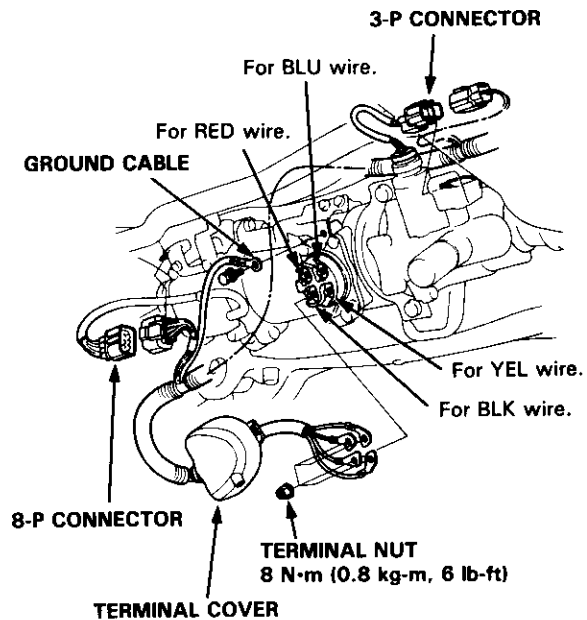

4. Adjust the rear sub steering angle sensor (see page 17-155).

NOTE:

- Be sure that the front sub steering angle sensor and front main steering angle sensor are in neutral and the steering wheel is in the straight ahead driving position.
- Be sure that the rear steering lock pin (special tool) is set in the rear actuator.

5. Install the terminal cover and rear steering actuator cover.

4WS Control Unit

Removal and Installation

1. Remove the rear seat back (see section 20).
2. Disconnect the terminal wires and connectors from the 4WS control unit.
3. Remove the 4WS control unit.

4WS CONTROL UNIT

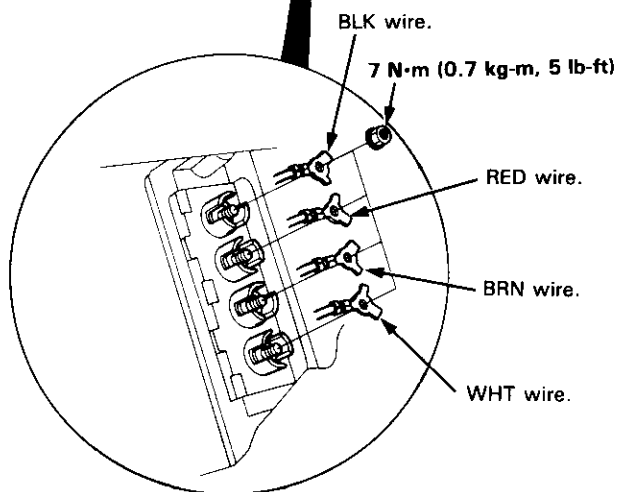
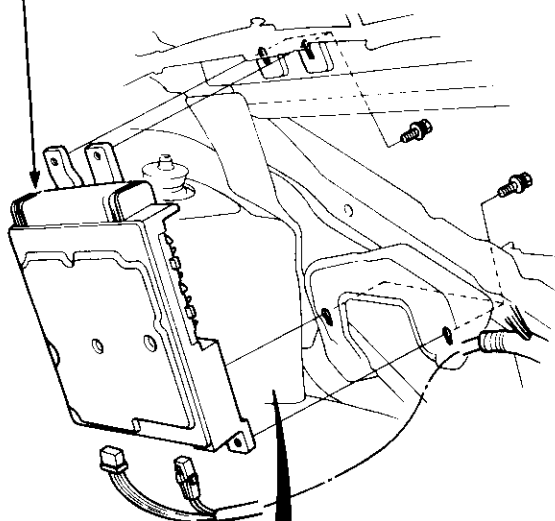

4. Install in the reverse order of removal.

NOTE: Turn the ignition switch ON and check the 4WS indicator light operation.

Tie-rod End Boot

Replacement

1. Remove the boot.
2. Pack the interior of the boot and lip with grease.
3. Wipe the grease off the sliding surface of the ball pin, then pack the lower area with fresh grease.

CAUTION:

- Keep grease off the boot installation section and the tapered section of the ball pin.
- Do not allow dust, dirt, or other foreign materials to enter the boot.

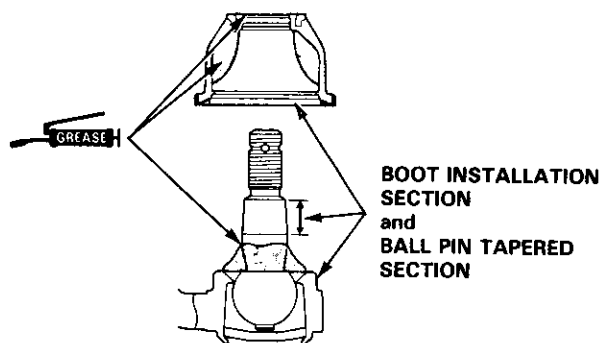

4. Install the new ball joint boot using the special tool as shown below.

NOTE: After driving the boot onto the ball joint, apply sealant between the tie-rod end and boot.

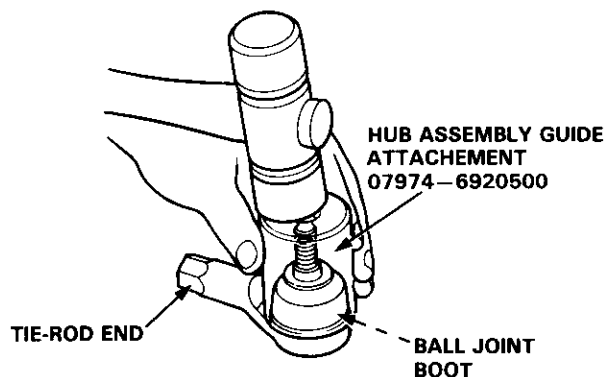

CAUTION: After installing the boot, check the ball pin tapered section for grease contamination and wipe it if necessary.

4WS System Inspection

Electronic Neutral Check

Preparation

NOTE:

- If the power of the 4WS control unit was shut down for the following operations, start the engine and turn the steering wheel fully right and left.
 - Battery removal/installation
 - 4WS control unit removal/installation
 - No. 43 fuse CLOCK RADIO removal (in the under-hood fuse/relay box)
- Before performing the electronic neutral check on the 4WS system check the following items.
 - Be sure that the steering wheel spoke angle is at the designated angle while driving straight ahead.
 - Be sure that the rear wheels are not steered to the right or left, but in the straight ahead driving position.

1. Jack up the car and place the four wheels slowly in the center of the turning radius gauge turn tables.
2. Place a piece of masking tape or equivalent approximately 300 mm (12.0 in) long on the top edge of the steering wheel. Place a mark on the tape at each of the following measurements:
 - Center (highest point of the steering wheel).
 - 9 mm (0.4 in) right and left of center (For front main steering angle sensor).
 - 18 mm (0.7 in) right and left of center (For front sub steering angle sensor adjustment).
 - 55 mm (2.2 in) right and left of center (For front sub steering angle sensor inspection).

NOTE: The specifications are the measurements on the outer circumference of the steering wheel.

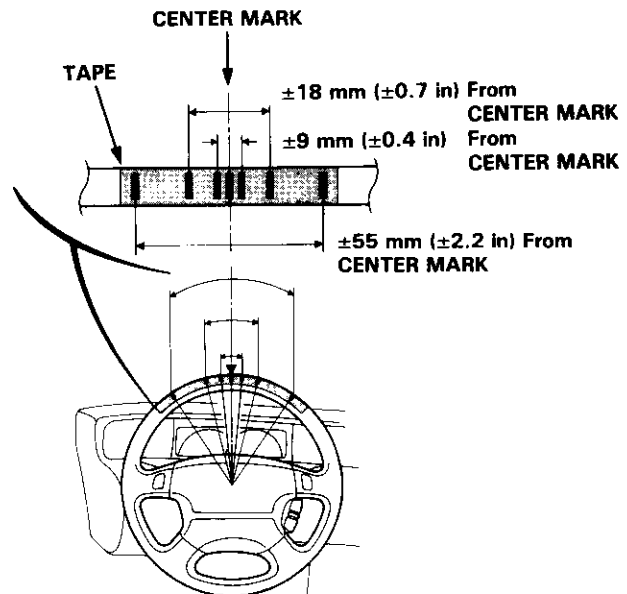

3. Fashion a piece of stiff wire (coat hanger) and place it on top of the dashboard. Position the wire so the indicating tip is close to the marks on the steering wheel and tape the wire down securely.
4. Set the steering wheel in the straight ahead driving position and set the wire at the center mark on the steering wheel.

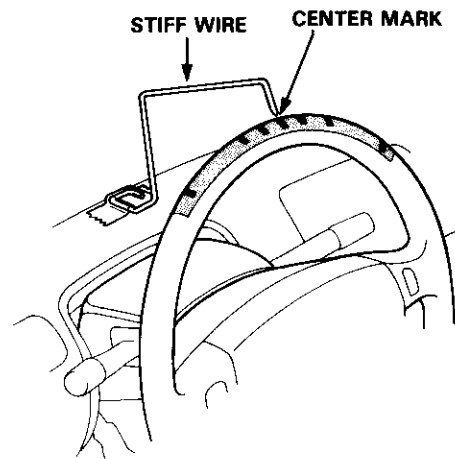



- Take out the service check connector (BLU 2P) from behind the center console. Connect the terminals with a piece of jumper wire.

NOTE:

- The 4WS indicator light will not indicate that sensors are in the neutral position when displaying stored problem codes.
- Check and verify any problem codes displayed before checking the neutral position.

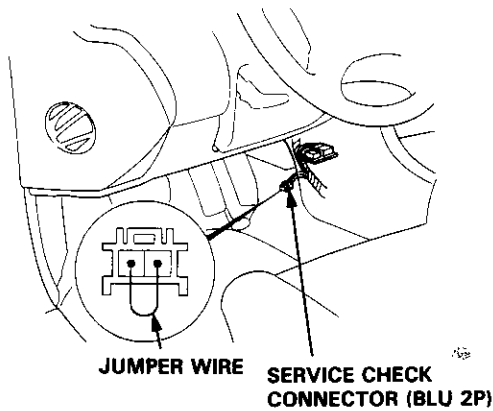

- Pull up the parking brake lever fully and turn the ignition switch on (engine off) to turn the parking brake indicator light on. This sets the front sensors in the inspection mode.

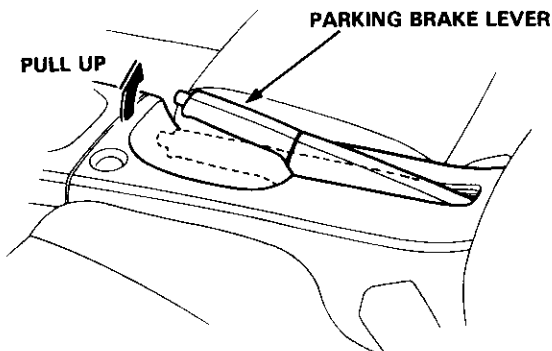

Front sensors inspection:

- Check the front main steering angle sensor with the ignition switch on (engine off).
 - From the straight ahead driving position, turn the steering wheel to the left, then turn the steering wheel slowly to the right beyond the straight ahead driving position. Do not turn the steering wheel inversely.
 - Turn the steering wheel to the left, then turn to the right beyond the straight ahead driving position. Repeat this operation several times until you find the position where the 4WS indicator light starts to come on steady.

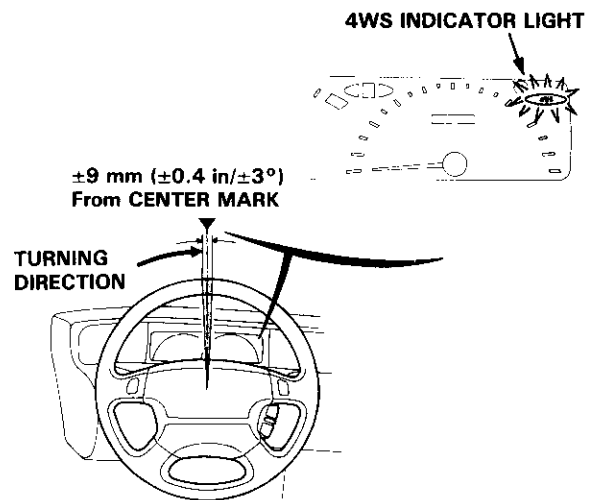

The 4WS indicator light should start to come on within the range of ± 9 mm (± 0.4 in/ $\pm 3^\circ$) from the center mark on the steering wheel.

NOTE:

- The 4WS indicator light might look as if it is blinking at a point near the ends of the specified range.
- To determine that the 4WS indicator light is on and not blinking, be sure that the 4WS indicator light stays on for more than 2 seconds.
 - Adjust the 4WS system if the indicator light starts to come on at a point outside the marked range on the steering wheel (see page 17-151).

(cont'd)

4WS System Inspection

Electronic Neutral Check (cont'd)

8. Check the front sub steering angle sensor with the ignition switch on (engine off).
 - From the straight ahead driving position, turn the steering wheel to the right, then turn it slowly to the left beyond the straight ahead driving position. Do not turn the steering wheel inversely.
 - Turn the steering wheel to the right, then turn to the left beyond the straight ahead driving position. Repeat this operation several times until you find the center point of the range where the 4WS indicator light blinks (at the intervals of 0.2 seconds).

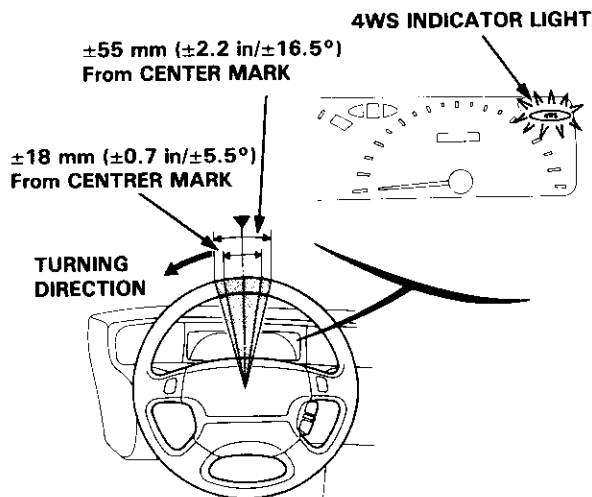

The center point should be within the range of ± 55 mm (± 2.2 in/ $\pm 16.5^\circ$) from the center mark on the steering wheel. After adjusting the front sub steering angle sensor, however, the center point should be within the range of ± 18 mm (± 0.7 in/ $\pm 5.5^\circ$) from the center mark.

- If the center point is outside the marked range on the steering wheel, adjust the front sub steering angle sensor (see page 17-153).

Rear sensors inspection:

9. Release the parking brake lever fully to turn off the parking brake indicator light. This sets the rear sensors in the inspection mode.

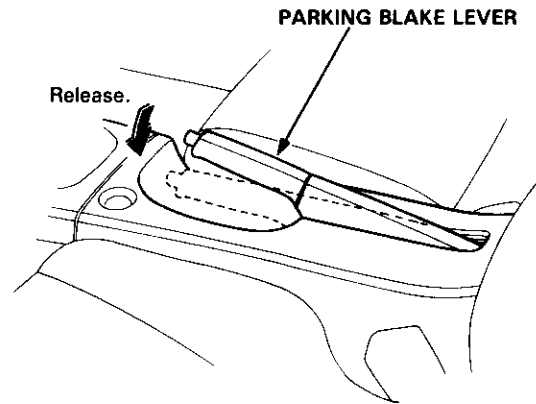

10. Turn the ignition switch off.

11. Remove the cap bolt and sealing washer from the rear steering actuator, and screw the special tool into the rear steering actuator as far as it will go.

NOTE: Do not start the engine with the special tool set in the rear steering actuator.

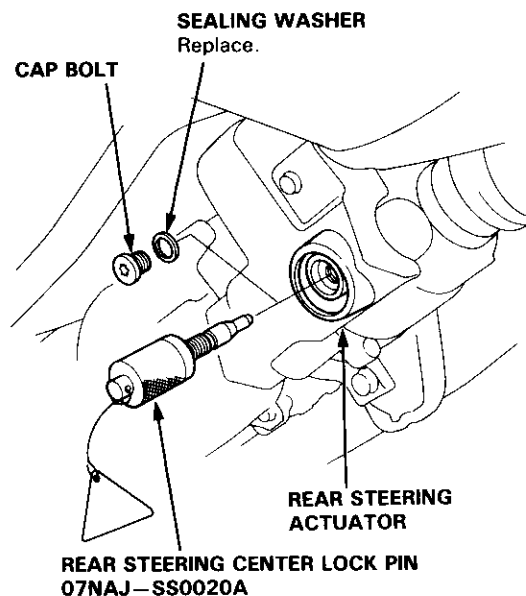



12. Set the steering wheel in the straight ahead driving position to prevent the rear wheels from steering if the engine is started in error.
13. Turn the ignition switch on (engine off) to check the rear sub steering angle sensor.
 - Push the rear left wheel fully to the right by hand, then push it slowly to the left.
 - The 4WS indicator light should blink at intervals of 0.2 seconds when the rear wheel is pushed to the left.

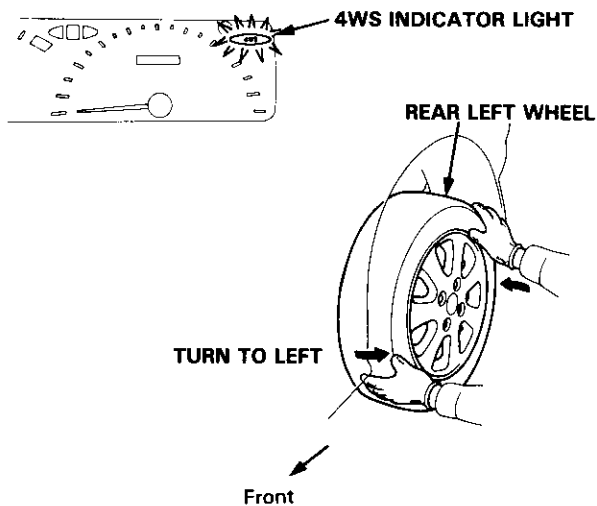

NOTE: The 4WS indicator light blinks in a narrow range. Take care not to overlook it.

- If the 4WS indicator light does not blink, adjust the rear sub steering angle sensor (see page 17-155).

14. Set the steering wheel in the straight ahead driving position to prevent the rear wheels from steering if the engine is started in error.
15. Turn the ignition switch on (engine off) and check the rear main steering angle sensor.
 - Push the rear left wheel fully to the left by hand, then push it slowly to the right.
 - The 4WS indicator light should turn ON when the rear wheel is pushed to the right.

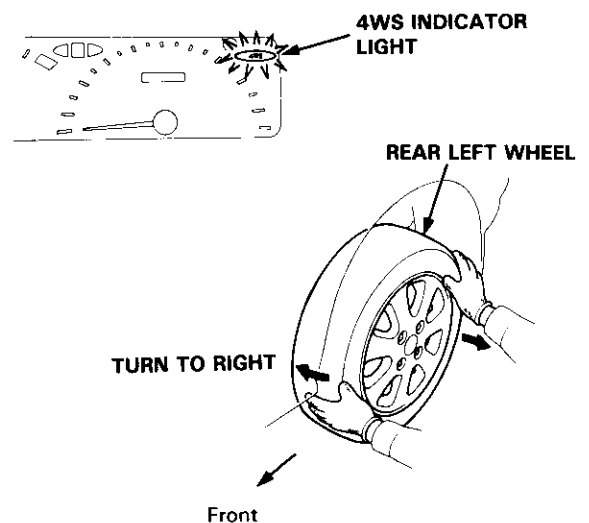

NOTE:

- The 4WS indicator light turns on in a narrow range. Take care not to overlook it.
- The 4WS indicator light might look as if it is blinking at a point near the ends of the range where the light is on.
- To determine that the 4WS indicator light is not blinking, be sure that the 4WS indicator light stays on for more than 2 seconds.
- If the 4WS indicator light does not turn on, remove the rear main steering angle sensor and check it for damage.

(cont'd)

4WS System Inspection

Electronic Neutral Check (cont'd)

16. Turn the ignition switch off.
17. Remove the special tool from the rear steering actuator, and install the cap bolt and the new sealing washer on the rear steering actuator.

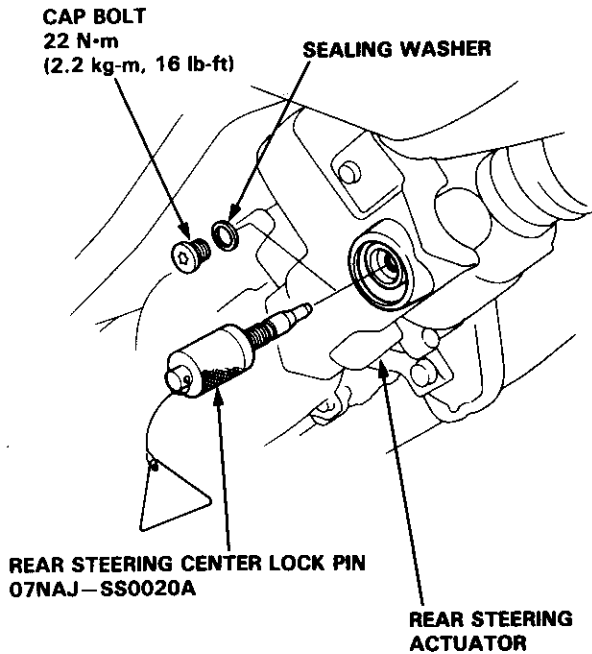

18. Remove the jumper wire from the service check connector terminals (BLU 2P).
19. Return the connector behind the center console.
20. Reinstall the removed parts.



4WS System Adjustment

4WS System Adjustment

Adjust the 4WS system using the following procedure.

NOTE:

- If the power of the 4WS control unit was shut down for the following operations, start the engine and turn the steering wheel fully right and left.
 - Battery removal/installation
 - 4WS control unit removal/installation
 - No. 43 fuse CLOCK RADIO removal (in the under-hood fuse/relay box)

1. Jack up the car and place the wheel in the center of the turning radius gauge turn tables.

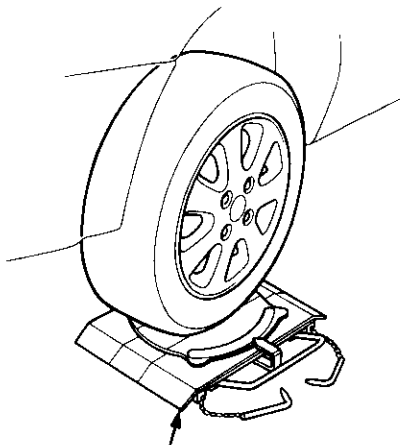

**TURNING RADIUS GAUGE
TURN TABLE**

2. Set the steering wheel so that it is positioned in the center of the range where the steering wheel turns fully to the right and left. (This centers the front steering rack.)
3. If the steering wheel spoke angle is not at the designated angle with the steering wheel set in the position explained in step 2, adjust the front main steering angle sensor and spoke angle as follows.
 - Set the steering wheel in the straight ahead driving position, then remove it.

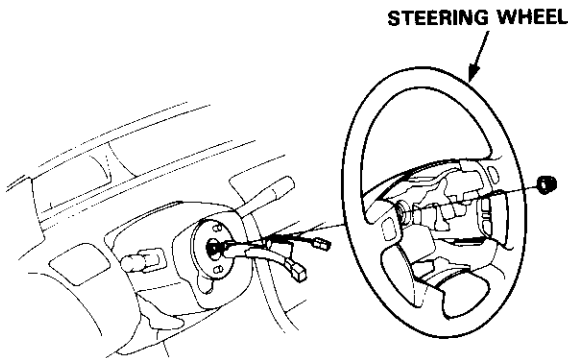

STEERING WHEEL

- Check whether the yellow paint mark of the front main steering angle sensor rotor is facing down (i.e. in neutral lock position where the rotor does not turn). This indicates that the front main steering angle sensor is electronically in neutral.

NOTE: If the paint mark is not facing down, adjust as instructed in step 5, (1) through (3) on page 17-87.

**FRONT MAIN STEERING
ANGLE SENSOR**

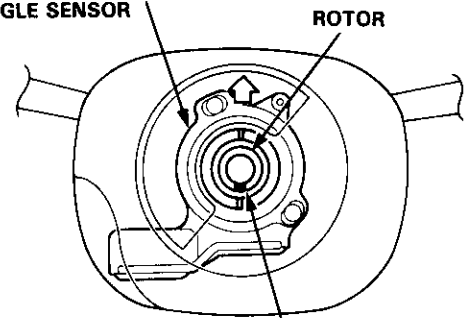

YELLOW PAINT MARK

- Install the steering wheel, aligning it with the serration which makes the spoke angle closest to horizontal.
 - If the spoke angle is not horizontal, adjust the steering wheel slightly right or left, being careful not to push in on the steering wheel.

STEERING WHEEL NUT

**50 N·m
(5.0 kg·m, 36 lb-ft)**

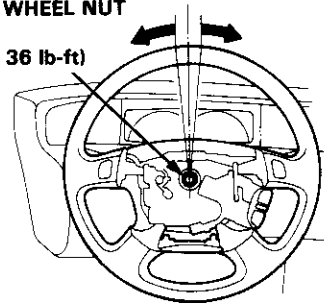

- With the spoke angle set at horizontal, then push the steering wheel in fully. Tighten the steering wheel nut while pushing the steering wheel in.

NOTE:

- Do not remove the steering wheel until adjustment is completed.
- Do not turn the steering wheel when pushing the steering wheel.

(cont c)

4WS System Adjustment

4WS System Adjustment (cont'd)

4. Be sure that the rear wheels are not steered to the right or left, but in the straight ahead driving position.

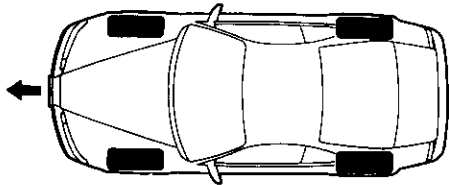

5. Take out the service check connector (BLU 2P) from behind the center console. Connect the terminals with a piece of jumper wire.

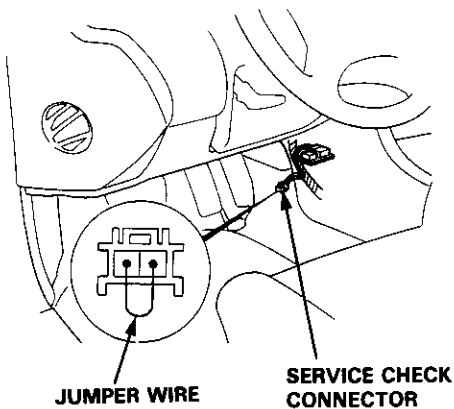

6. Check the sub and main steering angle sensors using the table shown below (see page 17-146).

NOTE:

- Turn the ignition switch on (engine off) to check.
- The 4WS indicator light does not indicate the electronic neutral position when it is indicating problem codes.
- Check the sensors by turning the specified wheel in the specified direction shown in the table below. The sensors are adjusted properly if the 4WS indicator light turns on in the specified range on the steering wheel, or if the center of the range where the 4WS indicator light blinks is within the specified range on the steering wheel.

Sensor type	Check	Parking brake lever	
		* 1 Pull	* 2 Release
Front main steering angle sensor	Turn front wheels to right	* 2 ON	—
Front sub steering angle sensor	Turn front wheels to left	* 3 Blinks	—
Rear sub steering angle sensor	* 4 Turn rear wheels to left	—	* 3 Blinks
Rear main steering angle sensor	* 4 Turn rear wheels to right	—	* 2 Blinks

* 1: Be sure that the parking brake indicator light operates properly.

* 2: The 4WS indicator light might look as if it is blinking at a point near the ends of the range where the light is ON.

* 3: The 4WS indicator light blinks in the intervals of 0.2 seconds. When the indicator light is indicating the main steering angle sensor condition (light ON), indication of the sub steering angle sensor condition by blinking is canceled.

* 4: Turn the rear wheel slowly by hand with the special tool (rear steering center lock pin) set in the rear steering actuator.



7. If the sensors are not adjusted properly, adjust each sensor.
 - If the front main steering angle sensor is not adjusted properly, start with the step 2.
 - Front sub steering angle sensor adjustment: see page 17-153.
 - Rear sub steering angle sensor: see page 17-155.

NOTE: The rear main steering angle sensor cannot be adjusted. If the rear main steering angle sensor is abnormal, remove it and check it for damage.

Sub Steering Angle Sensor Adjustment

Front Sub Steering Angle Sensor

NOTE: Before adjusting the sub steering angle sensor, check that the front main steering angle sensor is adjusted properly (see page 17-146).

1. Jack up the car and raise all four wheels off the ground. Place the safety stands in the proper locations to support the car (see section 1).
2. Set the steering wheel in the straight ahead driving position.
3. Take out the service check connector (BLU 2P) from behind the center console. Connect the terminals with a piece of jumper wire.

NOTE:

- The 4WS indicator light will not indicate that the sensors are in the electronic neutral position when displaying stored Diagnostic Trouble Codes (DTC).
- Check and verify problem codes displayed before checking the electronic neutral position.

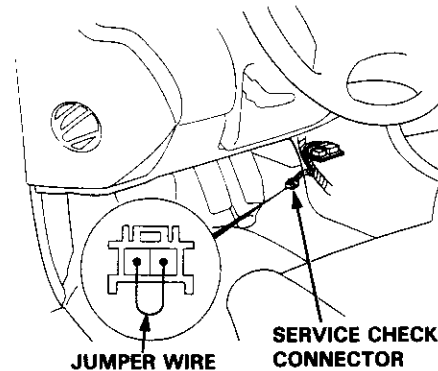

4. Set the parking brake lever and turn the ignition switch on (engine off). Be sure that the parking brake indicator light turns on.
5. Turn the ignition switch off.

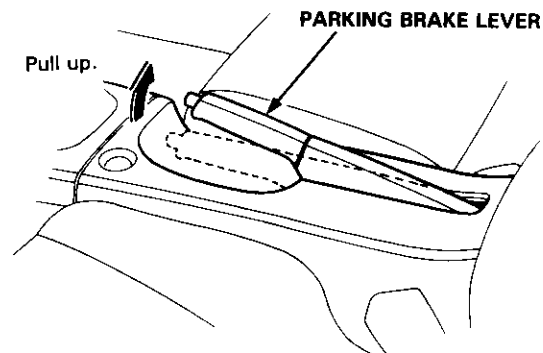

(cont'd)

4WS System Adjustment

Sub Steering Angle Sensor Adjustment (cont'd)

6. Cut the wire tie from the cover, then remove the cover from the front sub steering angle sensor.

CAUTION: Use care when cutting the wire tie so as not to cut into the wire harness.

7. Remove the sensor wire harness from the clamp and disconnect the connector.

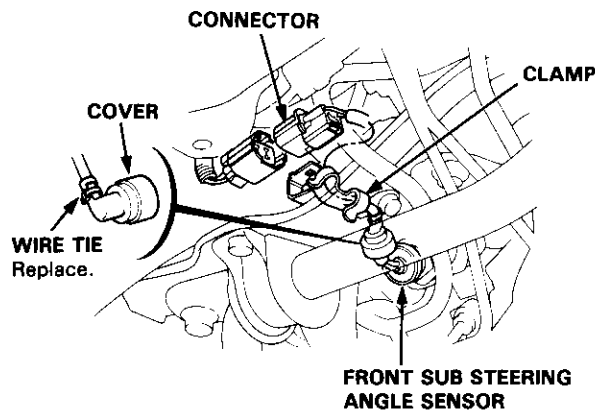

8. Loosen the locknut. Tighten the locknut fully by hand, back it off about 3/4 turns and connect the connector.

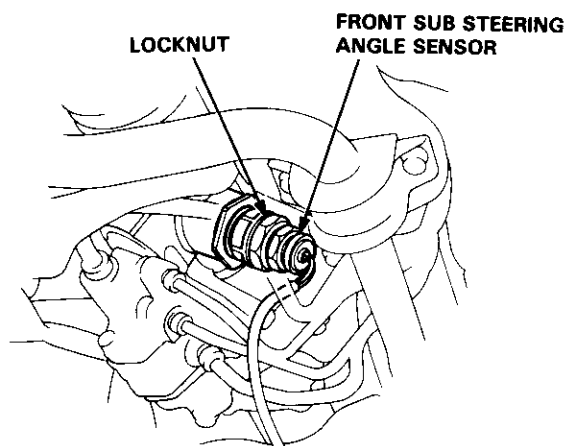

9. Turn the ignition switch on (engine off).

10. Set the steering wheel in the straight ahead driving position. Set the front main steering angle sensor electronically in neutral (4WS indicator light is blinking) this time.

NOTE: Hold the steering wheel in this position until adjustment is completed. If the steering wheel is moved in error, repeat the adjustment procedure starting with step 10.

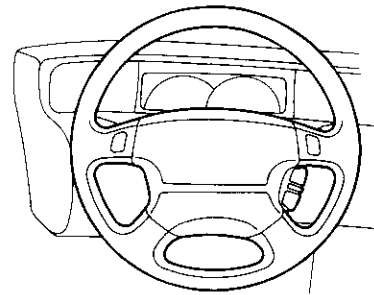

11. Turn the front sub steering angle sensor slowly clockwise, and check the range from where the 4WS indicator light starts to blink to where it stops.

12. Loosen the front sub steering angle sensor. Repeat the step 11 several times to set the sub steering angle sensor in the center of the range from where the 4WS indicator light starts to blink to where it stops.

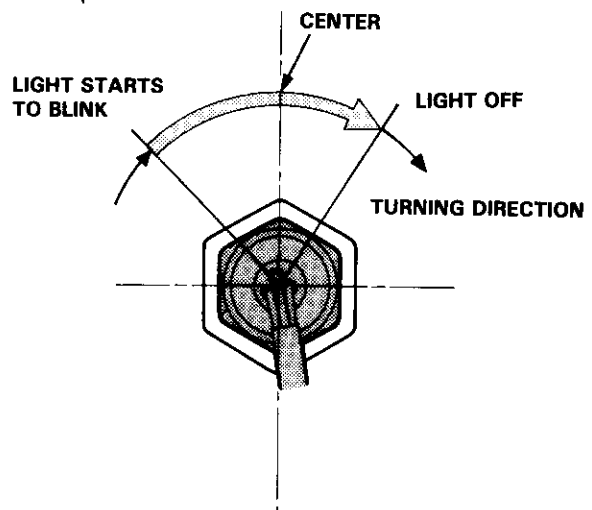

NOTE:

- Turn the front sub steering angle sensor clockwise to make the 4WS indicator light blink.
- If the sub steering angle sensor wire is twisted excessively, turn the ignition switch off, disconnect the connector, and straighten the wire.



13. Tighten the locknut while holding the front sub steering angle sensor with a wrench.

NOTE: Take care not to turn the front sub steering angle sensor.

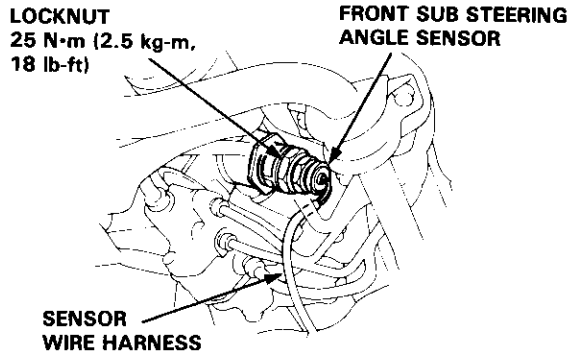

14. Disconnect the front sub steering angle sensor connector to straighten the sensor wire harness. Reconnect the connector.

NOTE: Do not contaminate the front sub steering angle sensor connector terminals with mud, oil, and grease.

15. Check that each sensor is electronically in neutral (see page 17-146).

NOTE: Be sure that the center of the range where the 4WS indicator light blinks (indicating that the front sub steering angle sensor is electronically in neutral), is in the range ± 18 mm (± 0.7 in/ $\pm 5.5^\circ$) from the center mark on the steering wheel.

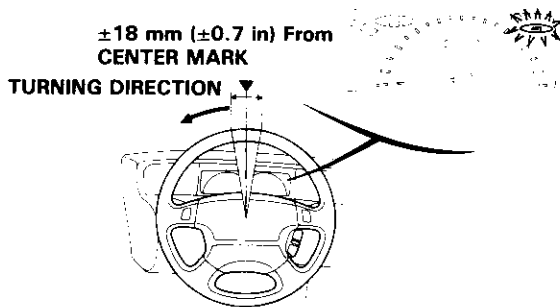

16. Reconnect the connector and secure the sub steering angle sensor wire harness with the clamp and install the cover.

NOTE:

- Be sure the sensor wire harness does not interfere with the stabilizer or other moving parts.
- Be certain that the wire is not twisted before connecting it.

17. Secure the cover with a new wire tie.

Rear Sub Steering Angle Sensor

1. Jack up the car and raise all four wheels off the ground. Place the safety stands in the proper locations to support the car (see section 1).
2. Take out the service check connector (BLU 2P) from behind the center console. Connect the terminals with a piece of jumper wire.

NOTE:

- The 4WS indicator light will not indicate that the sensor is in electronic neutral position, when displaying stored Diagnostic Trouble Codes (DTC).
- Check and verify problem codes displayed before checking the electrically neutral position.

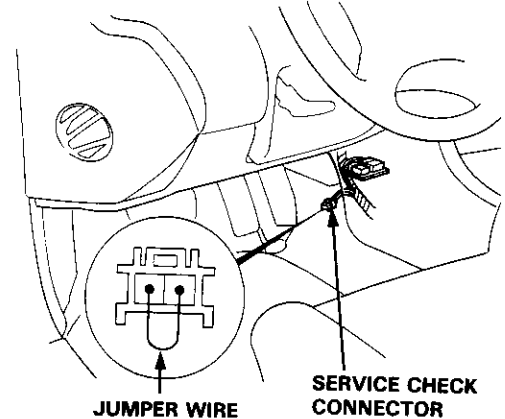

3. Release the parking brake lever fully and turn the ignition switch on (engine off). Be sure that the parking brake indicator light goes off.
4. Turn the ignition switch off.

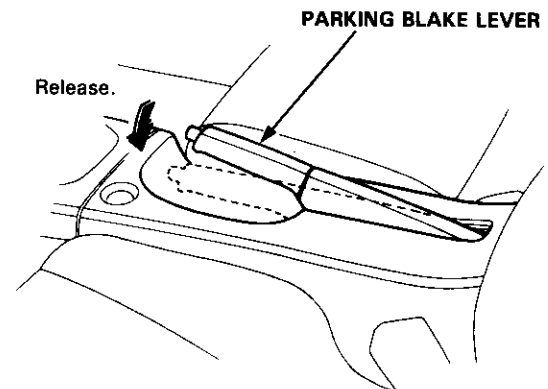

(cont'd)

4WS System Adjustment

Sub Steering Angle Sensor Adjustment (cont'd)

5. Remove the rear steering actuator cover
6. Remove the cap bolt and sealing washer from the rear steering actuator. Screw the special tool in as far as it will go.

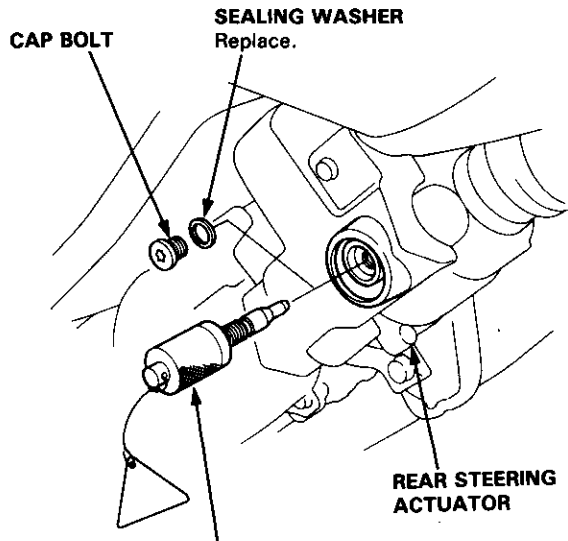

REAR STEERING CENTER LOCK PIN
07NAJ-SS0020A

7. Remove the rear sub steering angle sensor wire from the clamp and disconnect the connector.
8. Loosen the locknut. Tighten the locknut fully by hand, then back it off about 1/2 turn and connect the connector.

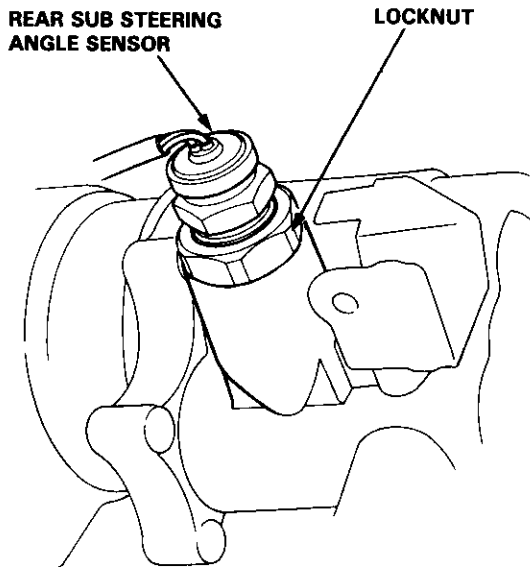

9. Set the steering wheel in the straight ahead driving position to prevent the rear wheels from steering if the engine is started in error.
10. Turn the ignition switch on (engine off).
11. Push the rear left wheel fully to the left by hand, then push it slowly to the right to turn the 4WS indicator light on (i.e. rear main steering angle sensor is electronically in neutral).

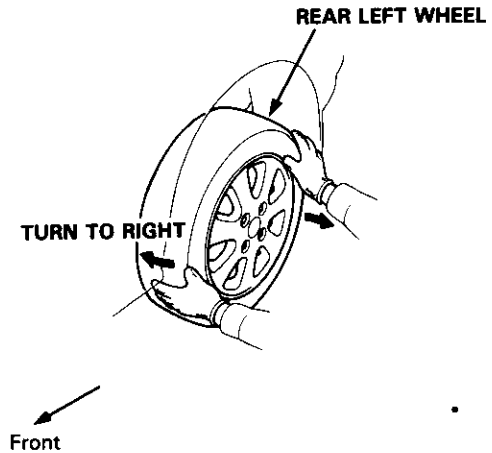

NOTE:

- The 4WS indicator light turns on in a narrow range. Do not overlook it.
- Work with care so as not to move the rear wheels from this neutral position.



12. Turn the ignition switch on (engine off).
13. Turn the rear sub steering angle sensor slowly counterclockwise, and check the range from where the 4WS indicator light starts to blink, to where it stops.
14. Tighten the rear sub steering angle sensor a little. Repeat the step 13 several times to set the sub steering angle sensor in the center of the range from where the 4WS indicator light starts to blink, to where it stops.

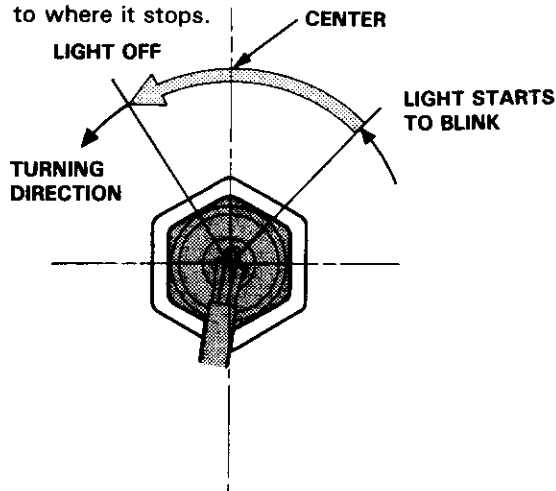

NOTE:

- Turn the rear sub steering angle sensor counterclockwise to make the 4WS indicator light blink.
- If the rear sub steering angle sensor wire is twisted excessively, turn the ignition switch off, disconnect the connector, and straighten the wire.

15. Tighten the locknut while holding the rear sub steering angle sensor with a wrench.

NOTE: Take care not to turn the rear sub steering angle sensor.

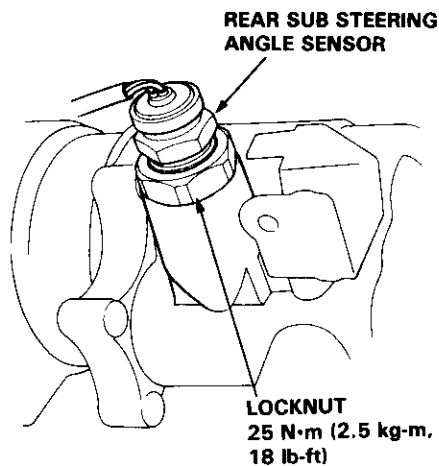

16. Disconnect the rear sub steering angle sensor connector to straighten the wire. Reconnect the connector.

NOTE: Do not contaminate the rear sub steering angle sensor connector terminals with mud, oil, and grease.

17. Check that each sensor is electronic in neutral (see page 17-146).
18. Turn the ignition switch off. Remove the special tool from the rear steering actuator, and install the cap bolt and the new sealing washer on the rear steering actuator.
19. Install the rear steering actuator cover.

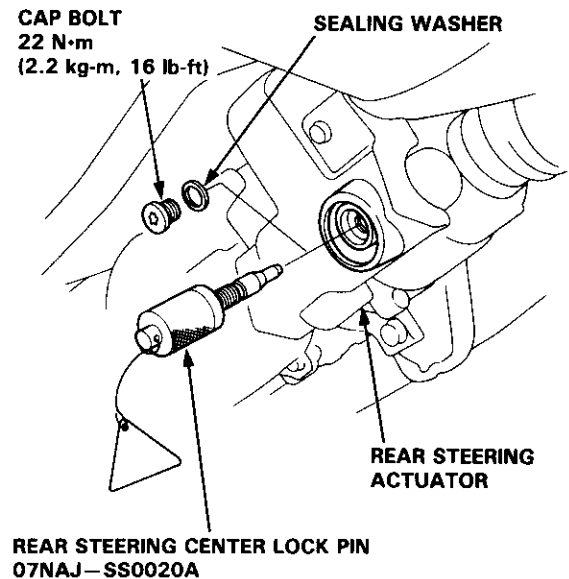

Suspension

Special Tools	18-2	Front Damper	
Component Location		Removal	18-22
Index	18-3	Disassembly/Inspection	18-22
Wheel Alignment		Reassembly	18-24
Service Information	18-4	Installation	18-25
Camber	18-5	Rear Suspension	
Caster	18-5	Torque Specifications	18-26
Front Toe Inspection/		Knuckle/Hub	
Adjustment	18-6	Illustrated Index	18-27
Rear Toe Inspection/		Removal	18-28
Adjustment	18-7	Installation	18-31
Turning Angle Inspection/		Suspension Arms	
Adjustment	18-8	Removal/Inspection	18-33
Wheel Measurements		Installation	18-34
Bearing End Play	18-9	Ball Joint Boot Replacement	18-35
Runout	18-9	Lower Arm Bushing Replacement	18-35
Front Suspension		Rear Damper	
Torque Specifications	18-10	Removal	18-36
Knuckle/Hub		Disassembly	18-37
Illustrated Index	18-11	Inspection	18-37
Removal	18-12	Reassembly	18-39
Hub Unit and Wheel Bearing		Installation	18-40
Replacement	18-15	Damper Disposal	18-41
Installation	18-17		
Suspension Arms			
Removal/Inspection	18-19		
Installation	18-20		
Ball Joint Boot Replacement	18-21		
Lower arm Bushing Replacement	18-21		



Special Tools

Ref. No.	Tool Number	Description	Q'ty	Page Reference
①	07GAF—SD40700	Hub Dis/Assembly Base	2	18-15
②	07GAF—SE00100	Hub Dis/Assembly Tool	1	18-15, 16, 17
③	07GAF—SE00200	Hub Assembly Guide Attachment	1	18-17
④	07GAG—SD40700	Ball Joint Boot Clip Guide	1	18-21, 35
⑤	07HAD—SG00100	Driver Attachment	1	18-16
⑥	07MAC—SL00100	Ball Joint Remover, 32 mm	1	18-14, 30
⑦	07MAC—SL00200	Ball Joint Remover, 28 mm	1	18-13, 14, 30, 36
⑧	07NAD—SS00100	Bushing Driver	1	18-21, 35
⑨	07746—0010500	Attachment, 62 x 68 mm	1	18-15
⑩	07749—0010000	Driver	1	18-15, 16
⑪	07965—SD90100	Support Base	1	18-16, 17
⑫	07974—SA50800	Ball Joint Boot Clip Guide	1	18-21, 35

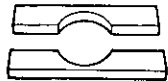

①



②



③



④ ⑫

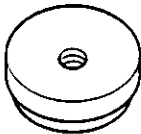

⑤

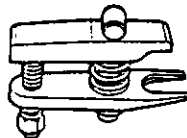

⑥ ⑦



⑧

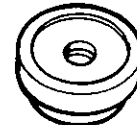

⑨



⑩

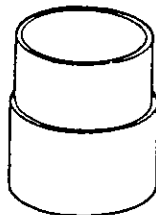

⑪

Component Location



Index

⚠ WARNING The front and rear dampers contain nitrogen gas and oil under pressure. The pressure must be relieved before disposal to prevent explosion and possible injury when scrapping.

Wheel Alignment, page 18-4

Front Suspension:

FRONT DAMPER

- Removal, page 18-22
- Disassembly/Inspection, page 18-22
- Reassembly, page 18-24
- Installation, page 18-25
- Disposal, page 18-41

FRONT LOWER ARM

- Removal/Inspection, page 18-19
- Installation, page 18-20

RADIUS ROD

- Removal/Inspection, page 18-19
- Installation, page 18-20

FRONT UPPER ARM

- Removal/Inspection, page 18-19
- Installation, page 18-20

STABILIZER BAR

- Removal/Inspection, page 18-19
- Installation, page 18-20

FRONT KNUCKLE/HUB

- Removal, page 18-12
- Bearing Replacement, page 18-15
- Installation, page 18-17

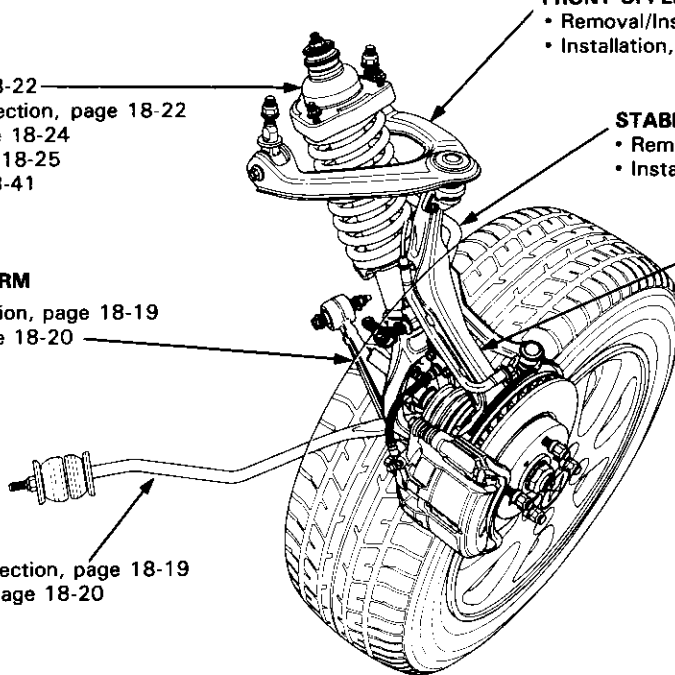

Rear Suspension:

REAR DAMPER

- Removal, page 18-36
- Disassembly, page 18-37
- Inspection, page 18-37
- Reassembly, page 18-39
- Installation, page 18-40
- Disposal, page 18-41

REAR UPPER ARM

- Removal/Inspection, page 18-33
- Installation, page 18-34

REAR KNUCKLE/HUB

- Removal, page 18-28
- Installation, page 18-31

REAR LOWER ARM

- Removal/Inspection, page 18-33
- Installation, page 18-34

TRAILING ARM

- Removal/Inspection, page 18-33
- Installation, page 18-34

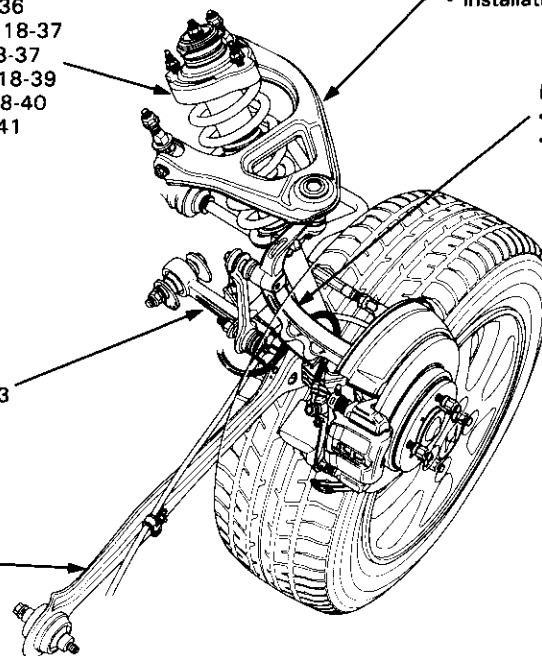

Wheel Alignment

Service Information

NOTE: For proper inspection/adjustment of the wheel alignment, check and adjust the following before checking the alignment.

- Check that the suspension is not modified.
- Check the tire size and tire pressure.
- Check the runout of the wheels and tires.
- Check the suspension ball joints. (Hold a wheel with your hands and move it up and down and right and left to check for wobbling.)

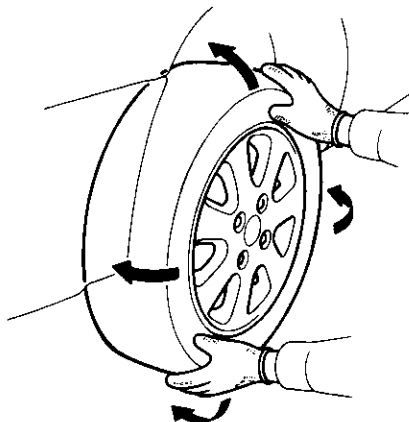

Wheel alignment adjustment procedure

Each of the wheel alignment elements relates to the other. Therefore, the total adjustment of the front/rear wheel alignment is required whenever either one of elements (i.e. camber, caster, toe, and/or turning angle) is adjusted.

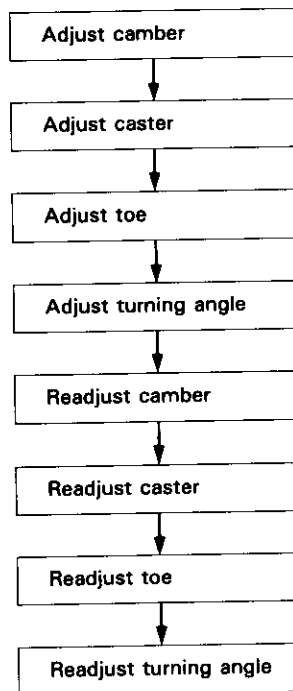



Camber

Inspection

NOTE: Use commercially available computerized four wheel alignment equipment to measure wheel alignment (i.e. caster, camber, toe, and/or turning angle). Follow the equipment manufacturer's instructions.

1. Check the tire pressure.
2. Turn the front wheels to the straight ahead position.
3. Check the camber angle.

Camber angle, Front: $0^{\circ}00' \pm 1^{\circ}$
Rear: $-0^{\circ}45' \pm 1^{\circ}$ (2WS)
 $-0^{\circ}45' \pm 30'$ (4WS)

4. Front: If out of specification, check for damaged suspension components.

Rear (2WS): If out of specification, check for damaged suspension components.

(4WS): — If adjustment is required, go to step 5.
 — If no adjustment is required, remove alignment equipment.

Rear Camber Adjustment (4WS)

5. Hold the adjusting bolt and loosen the self-locking nut.
6. Adjust the rear camber by turning the adjusting bolt until camber is correct.
7. Install the new self-locking nut and tighten while holding the adjusting bolt.

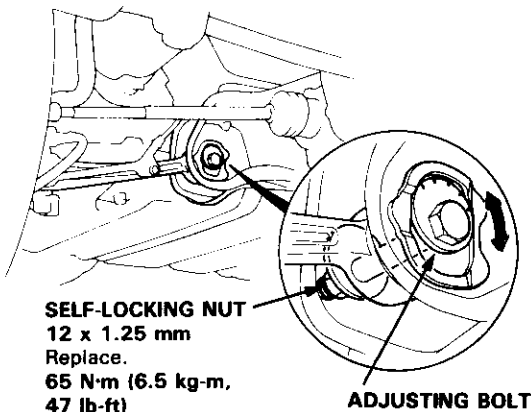

Caster

Inspection

NOTE: Use commercially available computerized four wheel alignment equipment to measure wheel alignment (i.e. caster, camber, toe, and/or turning angle). Follow the equipment manufacturer's instructions.

1. Turn the front wheels to the straight ahead position.
2. Check the caster angle.

Caster angle: $2^{\circ}40' \pm 1^{\circ}$

3. If adjustment is required, record the caster reading, then go to step 4. If adjustment is not required, remove alignment equipment.

NOTE: Caster angle can be adjusted by increasing/decreasing the number of the adjusting shims. Remove and install the radius rod each time the caster angle is adjusted.

4. Raise the front end of the car and place safety stands in the proper locations (see section 1).
5. Remove the self-locking nut on the end of the radius rod.
6. Remove the radius rod attaching bolts at the lower arm, then remove the radius rod (page 18-19).
7. Adjust the caster angle by increasing/decreasing the adjusting shims.
 - One adjusting shim changes the caster angle by $40'$ and the caster angle can be adjusted by $1^{\circ}20'$ maximum.
 - One adjusting shim is 3.2 mm (0.13 in) in thickness.

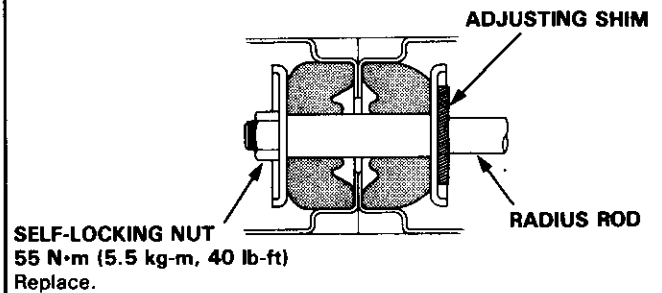

NOTE:

- Do not use more than two adjusting shims.
- After the adjustment, tighten the self-locking nut to the specified torque.

Wheel Alignment

Front Toe Inspection/Adjustment

NOTE: Use commercially available computerized four wheel alignment equipment to measure wheel alignment (i.e. caster, camber, toe, and/or turning angle). Follow the equipment manufacturer's instructions.

1. Check the tire pressure.
2. **2WS:** Set the front wheels to the straight ahead position.
4WS: Set the front main steering angle sensor in the neutral position and jump the service check connector to turn the 4WS indicator ON (see page 17-156).

NOTE: Maintain this condition during inspection and adjustment.

4WS INDICATOR

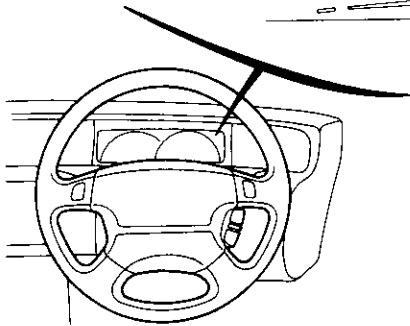
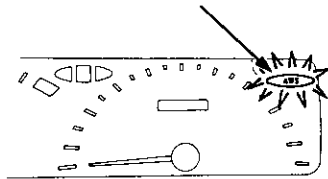

3. Check the front toe.

Front toe: 0 ± 2.0 mm (0 ± 0.08 in)

- If adjustment is required, go on to step 5. ✓
- If no adjustment is required, remove alignment equipment.

4. Loosen the tie-rod locknuts and turn both tie-rods in the same direction until the front wheels are in straight ahead position.
5. Turn both tie-rods equally until the toe is correct.
6. After adjusting, tighten the tie-rod locknuts.

NOTE: Reposition the tie-rod boot if it is twisted or displaced.

TIE-ROD LOCKNUT

14 x 1.5 mm
45 N·m (4.5 kg-m, 33 lb-ft)

TIE-ROD

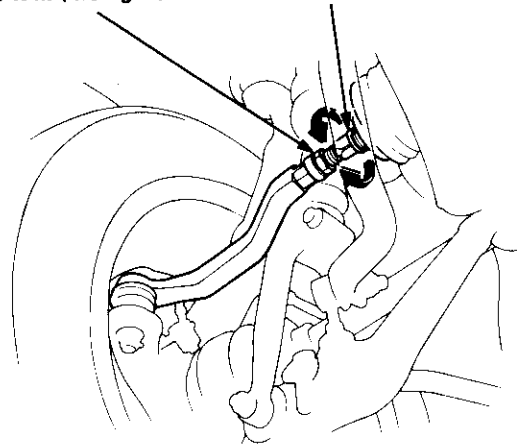



Rear Toe Inspection/Adjustment

NOTE: Use commercially available computerized four wheel alignment equipment to measure wheel alignment (i.e. caster, camber, toe, and/or turning angle). Follow the equipment manufacturer's instructions.

1. 4WS only: Check the rear main steering angle sensor is in the neutral position and jump the service check connector to turn the 4WS indicator ON (see page 17-156).

NOTE: Maintain this condition during inspection.

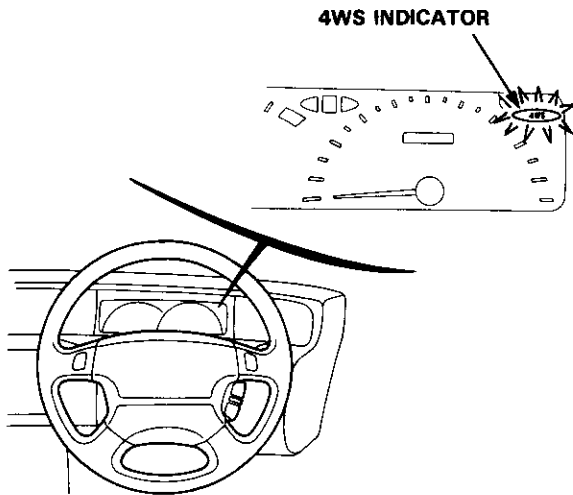

2. Release parking brake.
3. Check the rear toe.

NOTE:

- Measure difference in toe measurements with the wheels pointed straight ahead.
- If the parking brake is engaged, you may get an incorrect reading.

Rear toe-in: 2.0 ± 2.0 mm (0.08 ± 0.08 in)

- If adjustment is required, go to step 4.
- If no adjustment is required, remove alignment equipment.

4. 2WS:

- Hold the adjusting bolt on the rear lower arm B and loosen the self-locking nut.
- Adjust the rear toe by turning the adjusting bolt until toe is correct.
- Install the new self-locking nut and tighten while holding the adjusting bolt.

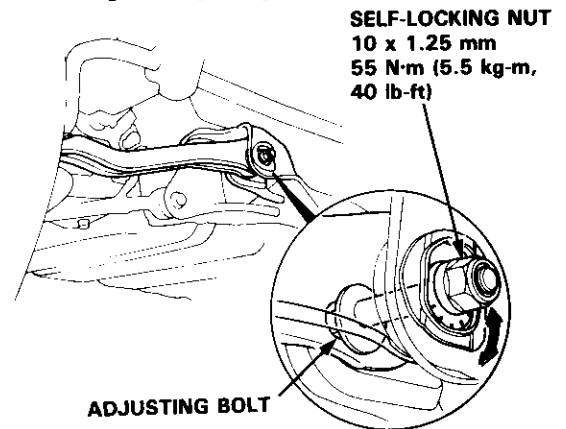

4WS:

- Loosen the tie-rod locknuts and turn both tie-rods in the same direction until the rear wheels are in the straight ahead position.

NOTE: Make sure the 4WS indicator is ON.

- Turn both tie-rods equally until the toe is correct.
- After adjusting, tighten the tie-rod locknuts.

NOTE: Reposition the tie-rod boot if it is twisted or displaced.

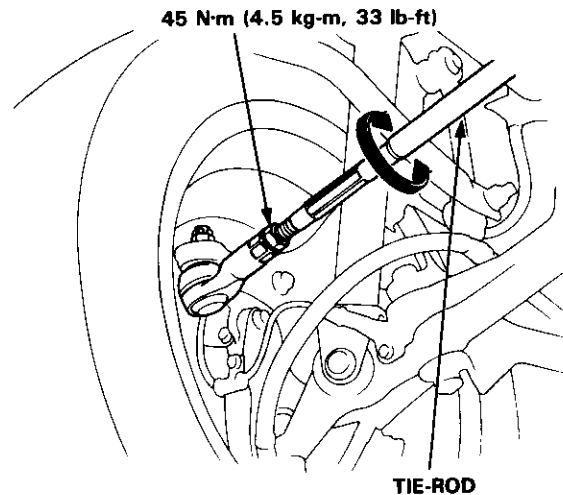

Wheel Alignment

Turning Angle Inspection/Adjustment

NOTE: Use commercially available computerized four wheel alignment equipment to measure wheel alignment (i.e. caster, camber, toe, and/or turning angle). Follow the equipment manufacturer's instructions.

1. Jack up the front of the car. Set the turning radius gauges beneath the front wheels, then lower the car.
2. 2WS: Jack up the rear of the car. Place boards that are the same thickness as the turning radius gauges under the rear wheels, then lower the car.
4WS: Jack up the rear of the car. Set the turning radius gauges beneath the rear wheels, then lower the car.

NOTE: For accurate readings, the car must be level.

3. Turn the wheel right and left while applying the brake. Measure the turning angle of both front wheels, and both rear wheels (4WS models).

Front turning angle:

Inward wheel: $36^{\circ}20' \pm 2^{\circ}$

Outward wheel: $29^{\circ}40'$ (reference)

Rear turning angle (4WS):

Inward wheel: $6^{\circ}00' \pm 1^{\circ}$

Outward wheel: $6^{\circ}20'$ (reference)

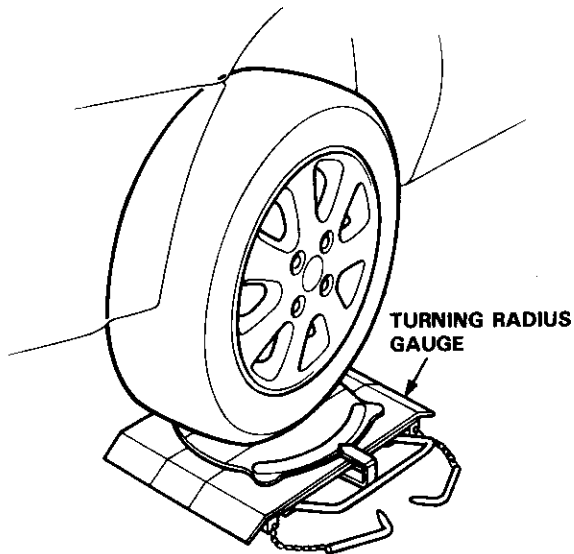

4. If the measurements are not within the specifications, adjust as required by turning the tie-rods.

NOTE: After adjusting, recheck the front wheel toe and readjust if necessary. Reposition the tie-rod boot if twisted or displaced.

TIE-ROD LOCKNUT

14 x 1.5 mm

45 N·m (4.5 kg-m, 33 lb-ft) TIE-ROD

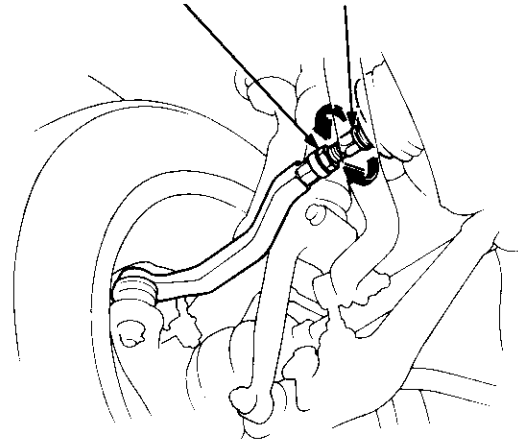

Wheel Measurements



Bearing End Play

1. Raise the car and support it with safety stands in the proper locations (see section 1).
2. Remove the wheels, then reinstall the lug nuts.
3. Attach the dial gauge as shown.
4. Measure the bearing end play by moving the disc in and out.

Front Wheel End Play:

Standard: 0–0.05 mm (0–0.002 in)

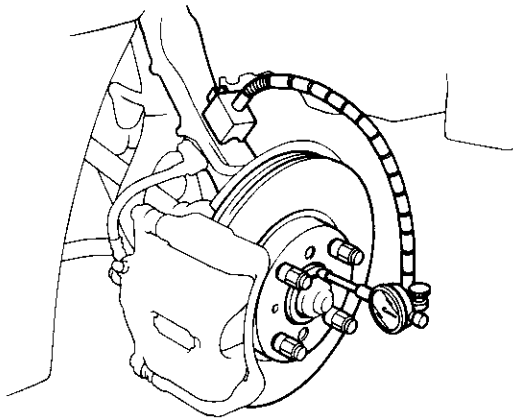

Rear Wheel End Play:

Standard: 0–0.05 mm (0–0.002 in)

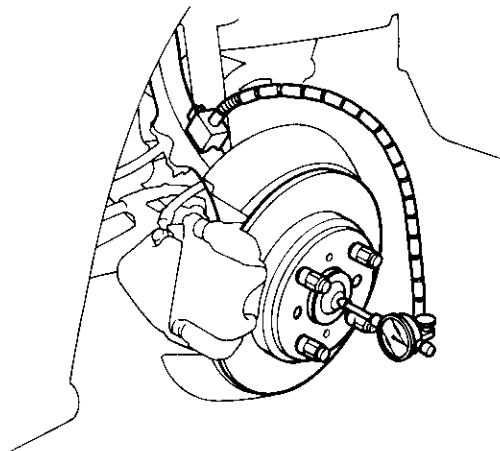

5. If the bearing end play measurement is more than the standard, replace the wheel bearing.

Runout

1. Raise the car and support it with safety stands in the proper locations (see section 1).
2. Check for bent or deformed wheels.
3. Attach the dial gauge as shown.
4. Measure the wheel runout by turning the wheel.

Front and Rear Wheel Axial Runout:

Standard:

Steel Wheel: 0–1.0 mm (0–0.04 in)

Aluminum Wheel: 0–0.7 mm (0–0.03 in)

Service Limit: 2.0 mm (0.08 in)

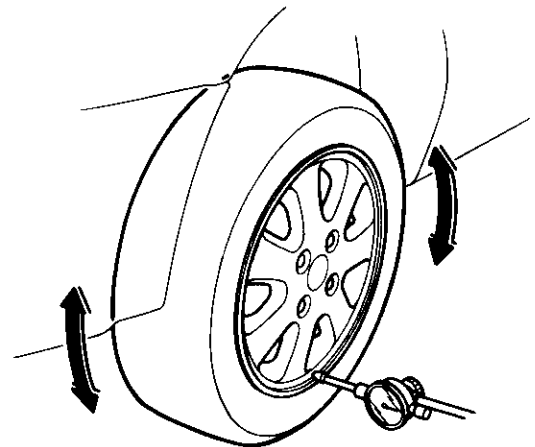

Front and Rear Wheel Radial Runout:

Standard:

Steel Wheel: 0–1.0 mm (0–0.04 in)

Aluminum Wheel: 0–0.7 mm (0–0.03 in)

Service Limit: 1.5 mm (0.06 in)

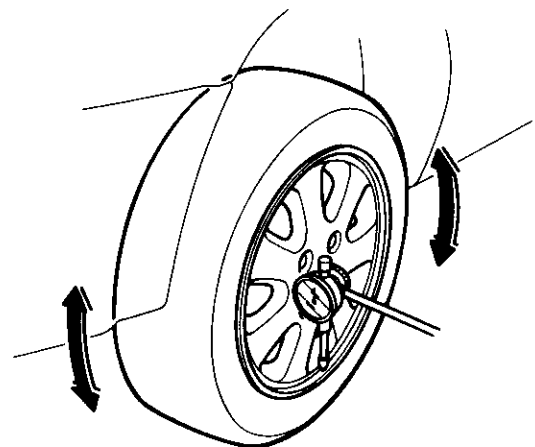

5. If the wheel runout is more than the service limit, replace the wheel.

Front Suspension

Torque Specifications

CAUTION:

- Replace the self-locking nuts after removal.
- Replace the self-locking bolts if you can easily thread a non-self-locking nut past their nylon locking inserts. (It should require 1 N·m (0.1 kg-m, 0.7 lb-ft) of torque to turn the nut on the bolt).
- The vehicle should be on the ground before any bolts or nuts connected to rubber mounts or bushing are tightened.
- Torque the castle nut to the lower torque specification, then tighten it only far enough to align the slot with the pin hole. Do not align the nut by loosening.

NOTE: Wipe off the grease before tightening the nut at the ball joint.

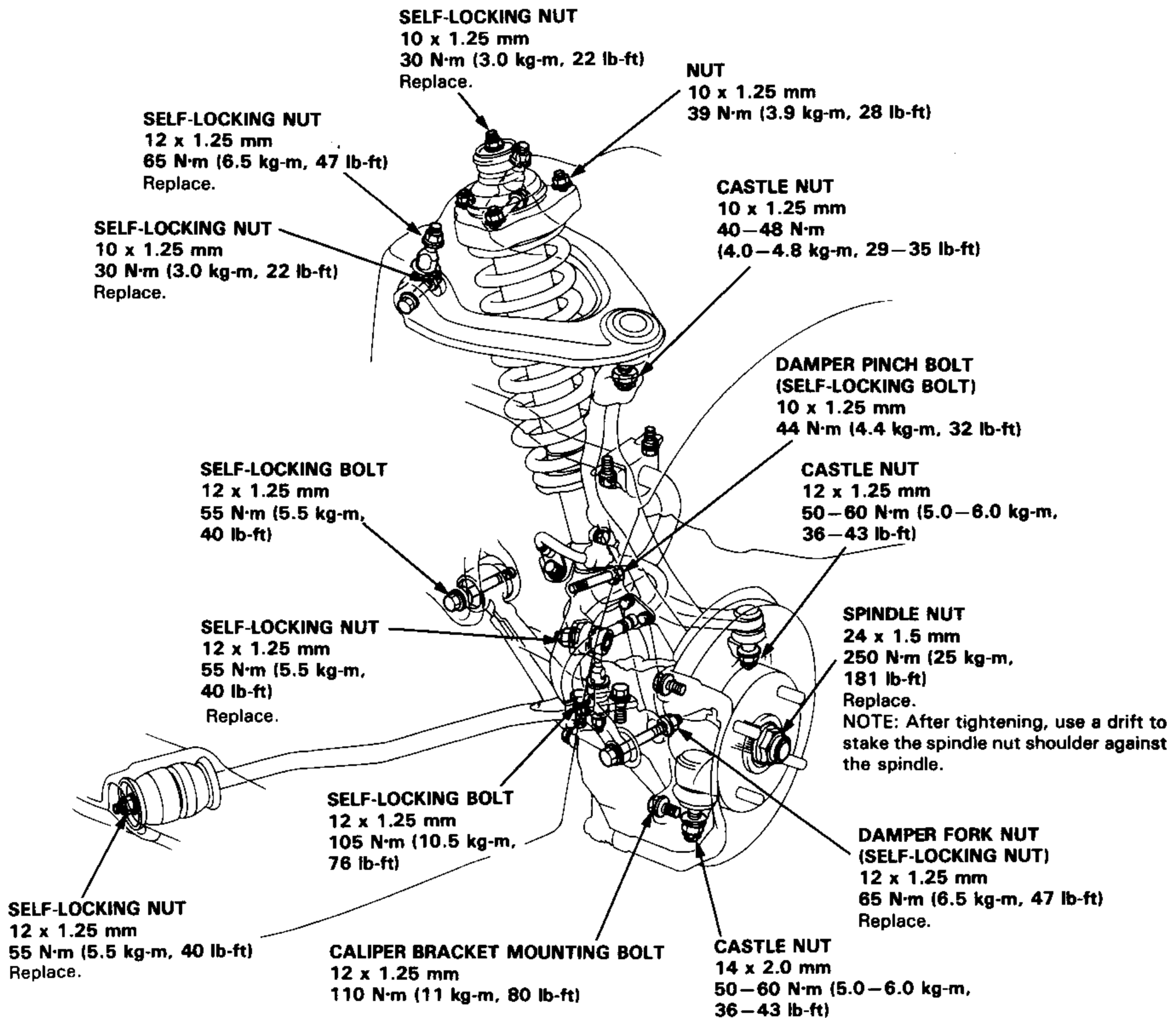



Knuckle/Hub

Illustrated Index

NOTE:

- Use only genuine Honda wheel weights for aluminum wheels. Non-genuine wheel weights may corrode and damage the aluminum wheels.
- Before installing the brake disc, clean the mating surfaces of the front hub and inside of the brake disc.
- Before installing the wheel, clean the mating surfaces of the brake disc and inside of the wheel.

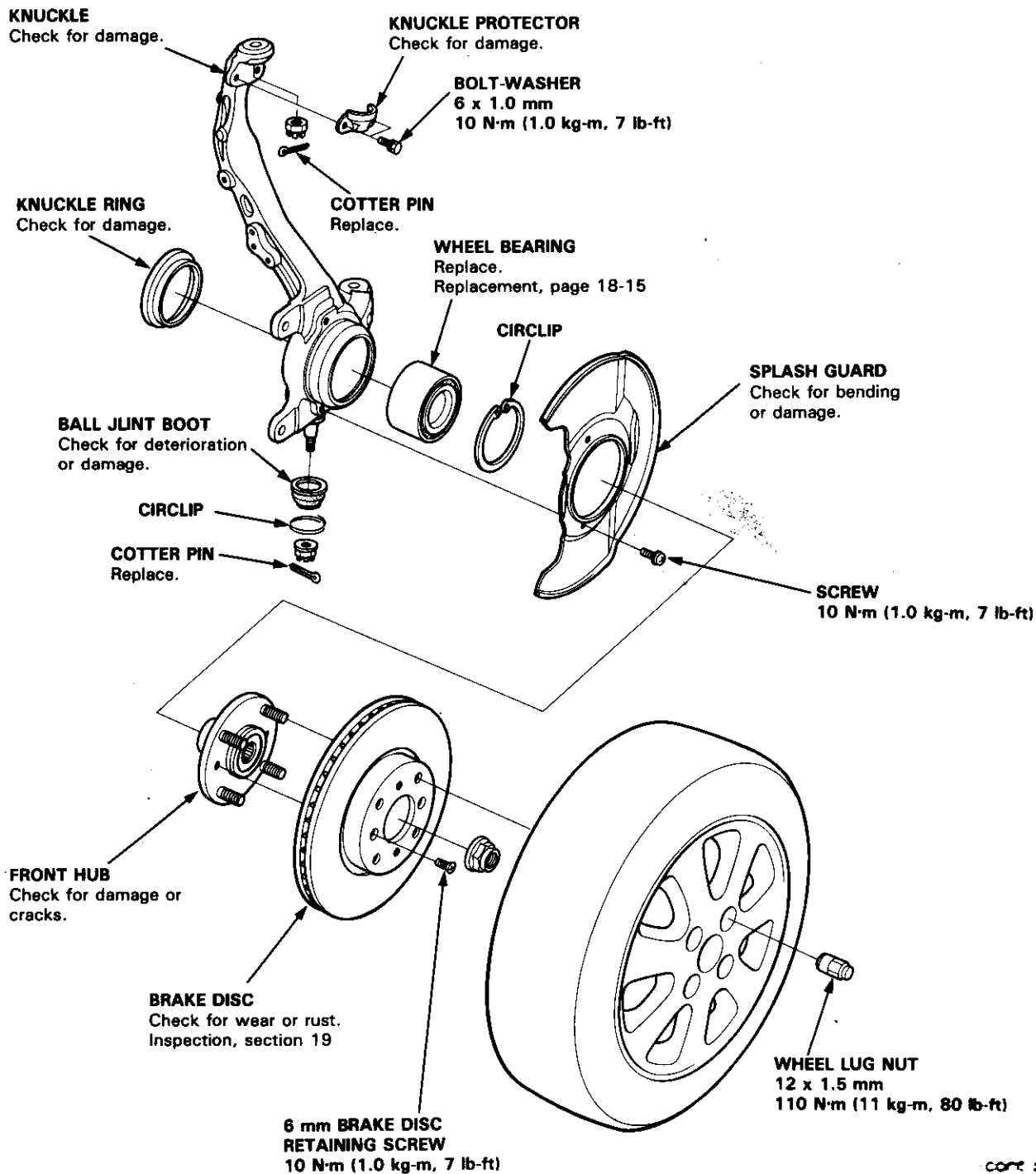

cont. 3

Front Suspension

Knuckle/Hub (cont'd)

Removal

1. Loosen the wheel nuts slightly.
2. Raise the front of car and support on safety stands in proper locations (see section 1).
3. Remove the wheel lug nuts and front wheel.
4. Raise the locking tab on the spindle nut, then remove the nut.

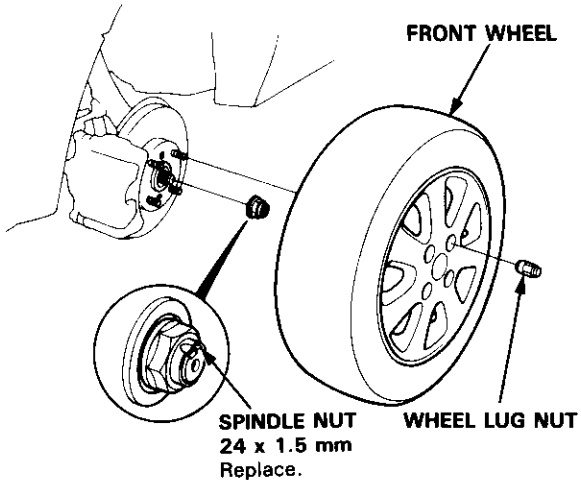

5. Remove the brake hose mounting bolts.
6. Remove the caliper bracket mounting bolts and hang the caliper assembly to one side.

CAUTION: To prevent accidental damage to the caliper assembly or brake hose, use a short piece of wire to hang the caliper assembly from the undercarriage.

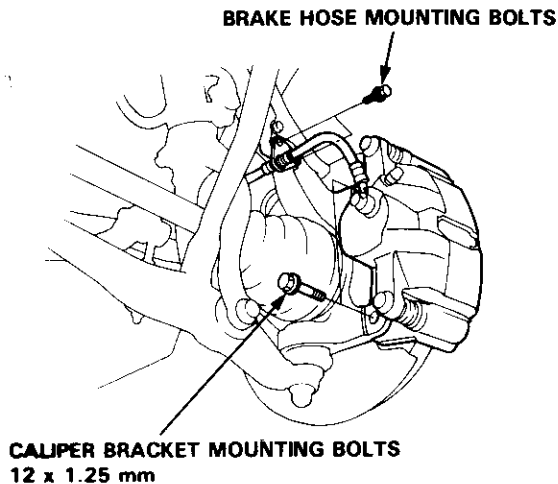

7. Remove the 6 mm brake disc retaining screws.
8. Screw two 8 x 1.25 mm bolts into the disc to push it away from the hub.

NOTE: Turn each bolt two turns at a time to prevent cocking the disc excessively.

9. Remove the brake disc from the knuckle.

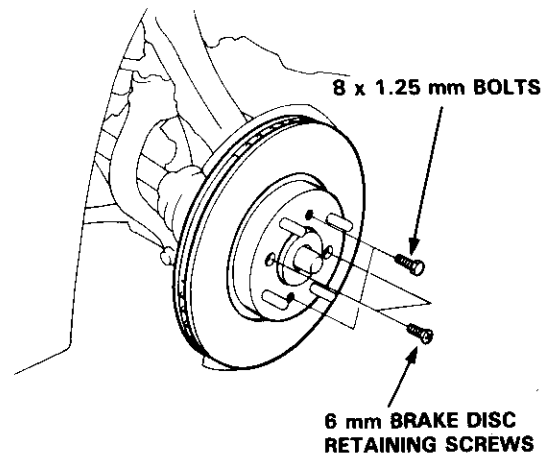

10. Remove the wheel sensor wire bracket, then remove the wheel sensor from the knuckle.

NOTE: Do not disconnect the wheel sensor wire.

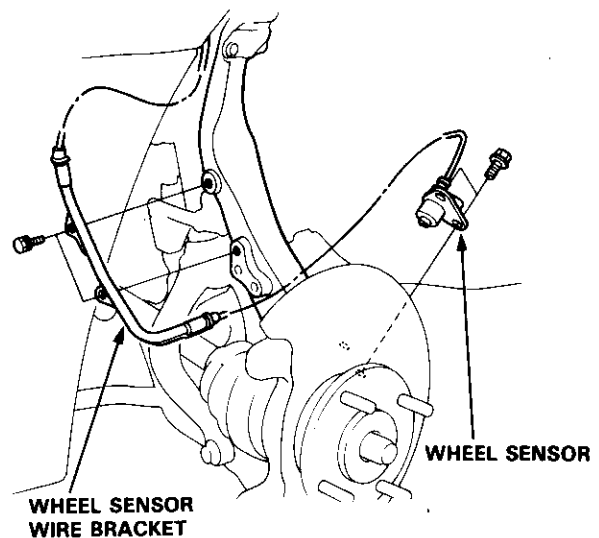



NOTE: Use ball joint remover, to separate the ball joints from the suspension or steering arm.

CAUTION: Be careful not to damage the ball joint boot.

11. Clean any dirt or grease off the ball joint.
12. Apply grease to the special tool on the areas shown. This will ease installation of the tool and prevent damage to the pressure bolt threads.

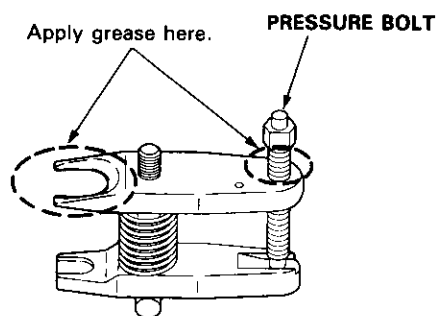

13. Remove the cotter pin from the steering arm and remove the nut.
14. Install a 12 mm hex nut on the ball joint. Be sure that the hex nut is flush with the ball joint pin end to prevent damage to the threaded end of the ball joint.
15. Use the ball joint remover as shown. Insert the jaws carefully, making sure you do not damage the ball joint boot. Adjust the jaw spacing by turning the pressure bolt.

NOTE: If necessary, apply penetrating type lubricant to loosen the ball joint.

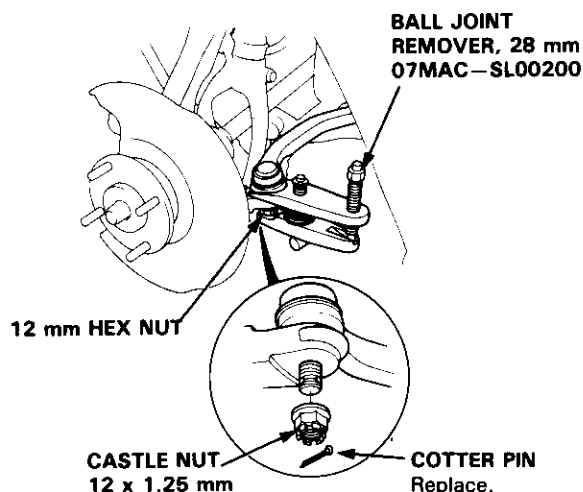

16. Once the tool is in place, turn the adjusting bolt as necessary to make the jaws parallel. Then hand-tighten the pressure bolt and recheck the jaws to make sure they are still parallel.

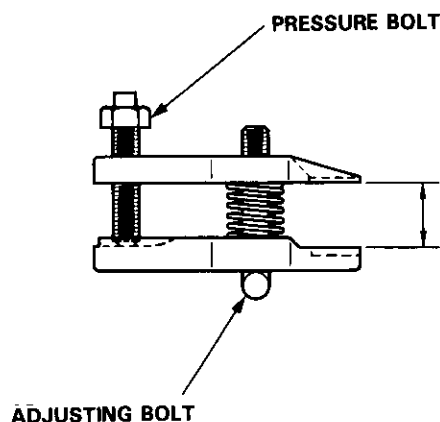

17. With a wrench, tighten the pressure bolt until the ball joint shaft pops loose from the steering arm.

⚠ WARNING Wear eye protection. The ball joint can break loose suddenly and scatter dirt or other debris in your eyes.

18. Remove the tool, then remove the nut from the end of the ball joint and pull the ball joint out of the steering/suspension arm. Inspect the ball joint boot and replace it if damaged.

(cont'd)

Front Suspension

Knuckle/Hub (cont'd)

19. Remove the cotter pin and lower arm ball joint nut.
20. Install a 14 mm hex nut on the ball joint. Be sure that the hex nut is flush with the ball joint pin end, or the threaded section of the ball joint pin might be damaged by the ball joint remover.
21. Use the ball joint remover as shown on page 18-13 to separate the ball joint and lower arm.

NOTE: If necessary, apply penetrating type lubricant to loosen the ball joint.

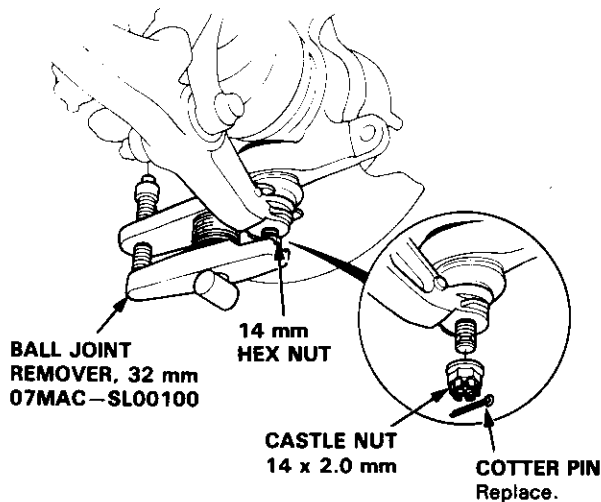

22. Remove the knuckle protector.
23. Remove the cotter pin and the upper ball joint nut.
24. Install a 10 mm hex nut on the ball joint. Be sure that the hex nut is flush with the ball joint pin end, or the threaded section of the ball joint pin might be damaged by the ball joint remover.
25. Use the ball joint remover as shown on page 18-13 to separate the ball joint and knuckle.

NOTE: If necessary, apply penetrating type lubricant to loosen the ball joint.

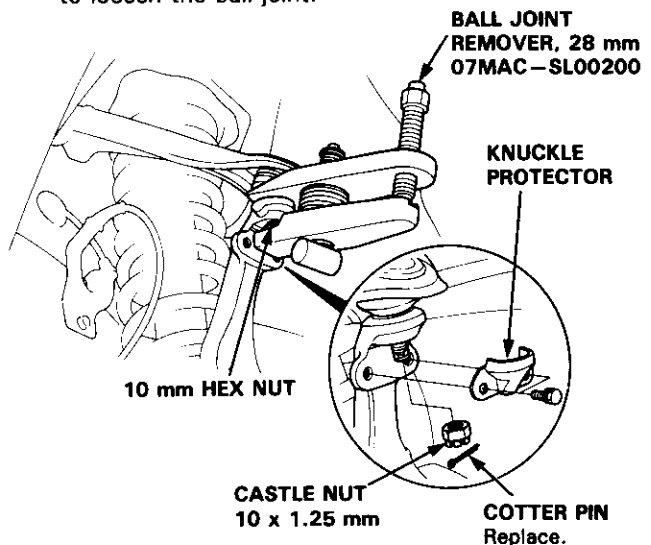

26. Pull the knuckle outward and remove the driveshaft outboard joint from the knuckle using a plastic hammer, then remove the knuckle.

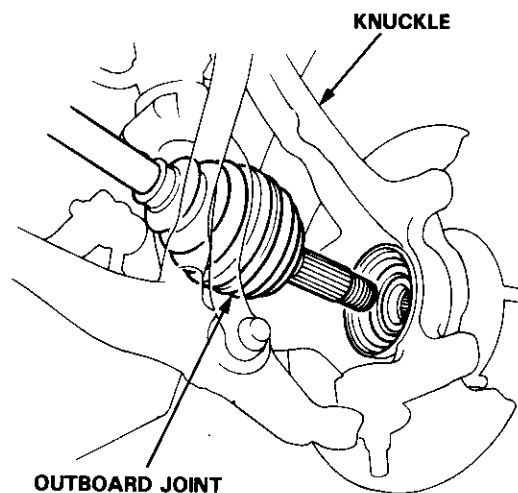



Hub Unit and Wheel Bearing Replacement

NOTE: Replace the bearing with a new one after removal.

27. Separate the hub from the knuckle using the special tools and a press.

CAUTION:

- Take care not to distort the splash guard.
- Hold onto the hub to keep it from falling when pressed clear.

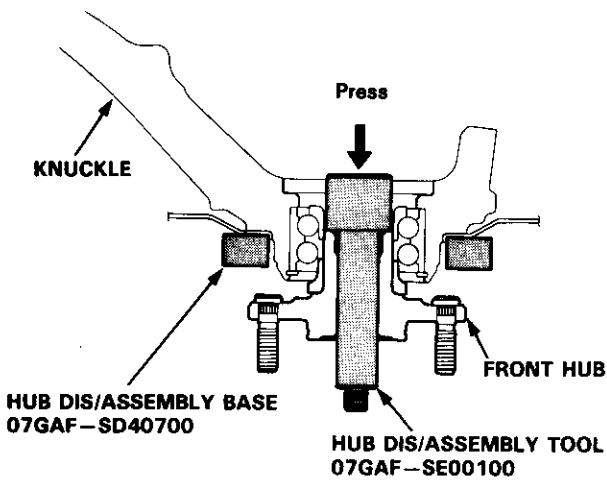

28. Remove the knuckle ring from the knuckle.

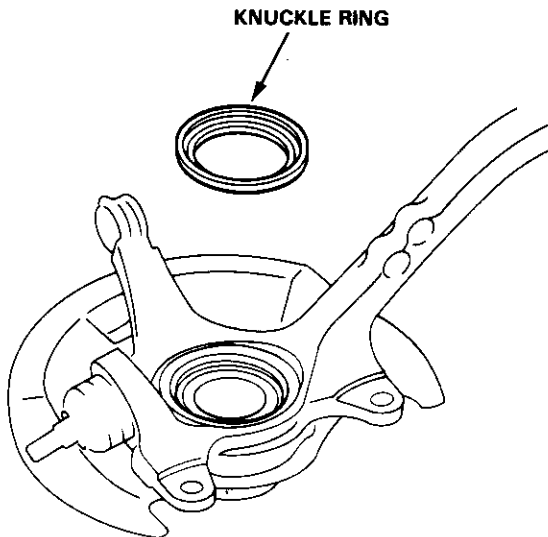

29. Remove the circlip and the splash guard from the knuckle.

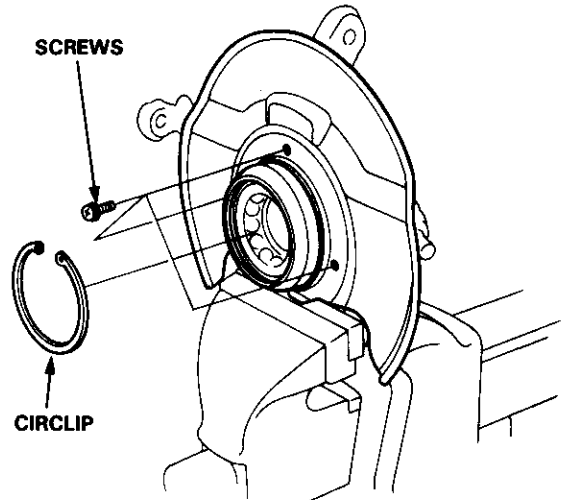

30. Press the wheel bearing out of the knuckle using the special tools and a press.

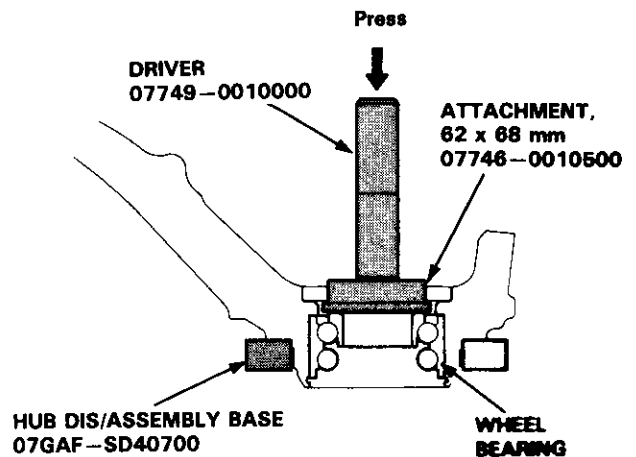

(cont'd)

Front Suspension

Knuckle/Hub (cont'd)

31. Press the wheel bearing inner race from the hub using the special tools and a commercially available bearing separator.

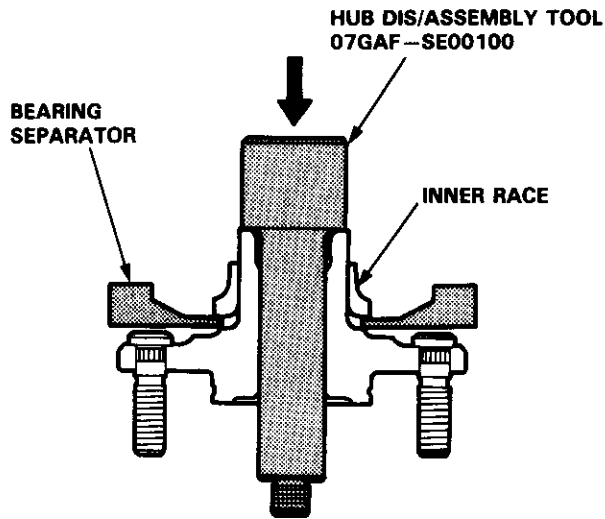

NOTE: Wash the knuckle and hub thoroughly in high flash-point solvent before reassembly.

32. Press a new wheel bearing into the hub using the special tools shown and a press.

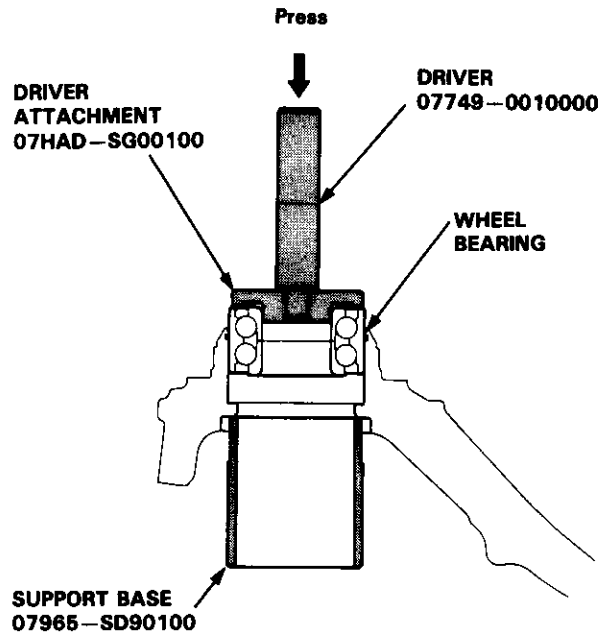

33. Install the circlip securely in the knuckle groove.

34. Install the splash guard and tighten the screws.

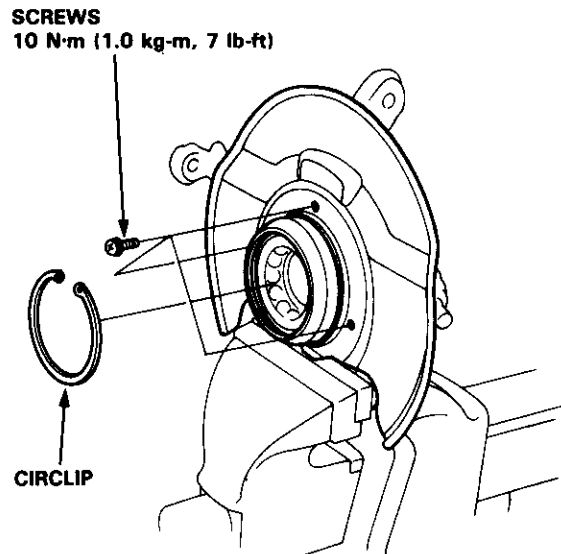



35. Install the hub on the knuckle using the special tools shown and a press.

CAUTION: Take care not to distort the splash guard.

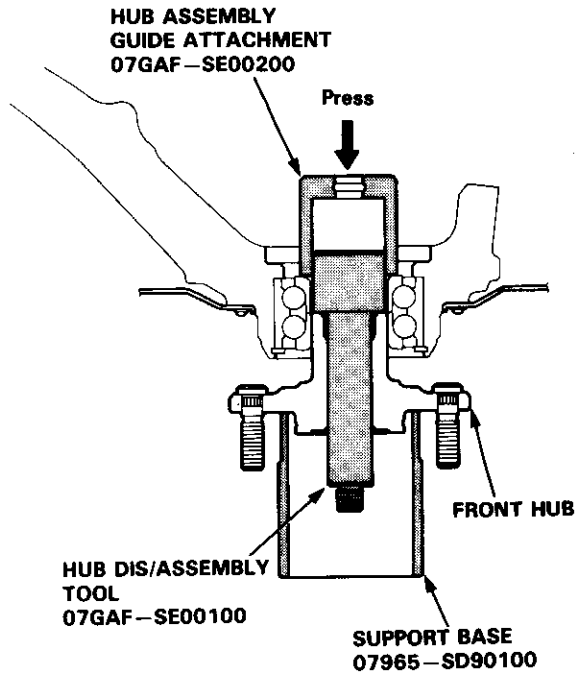

36. Install the knuckle ring on the knuckle.

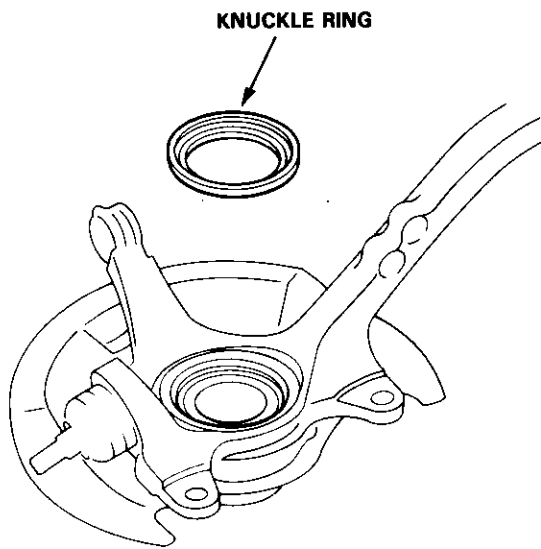

Installation

CAUTION:

- Be careful not to damage the ball joint boot.
- Torque the castle nut to the lower torque specification, then tighten it only far enough to align the slot with the pin hole. Do not align the nut by loosening.

37. Install the knuckle on the driveshaft.

38. Install the knuckle on the lower arm and the tie-rod, then tighten the castle nuts and install new cotter pins.

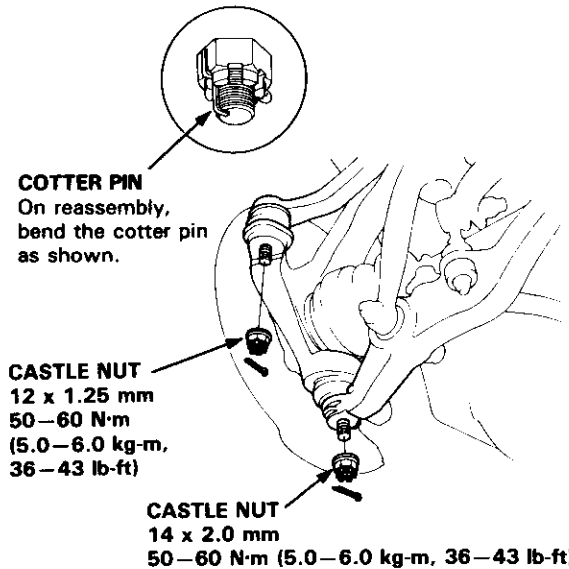

39. Install the knuckle on the upper arm, then tighten the castle nut and install a new cotter pin.

40. Install the knuckle protector with the 6 mm bolt.

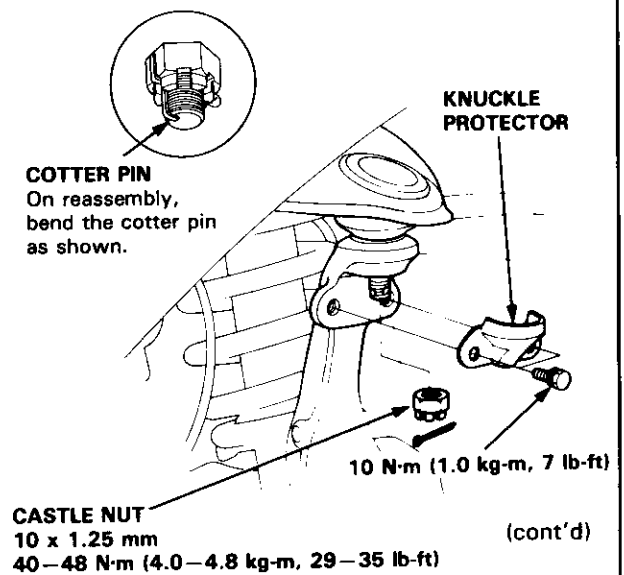

(cont'd)

Front Suspension

Knuckle/Hub (cont'd)

41. Install the wheel sensor with the sensor mounting bolts.

NOTE: Be careful when installing the sensors to avoid twisting wires.

42. Install the sensor wire with the two bolts.

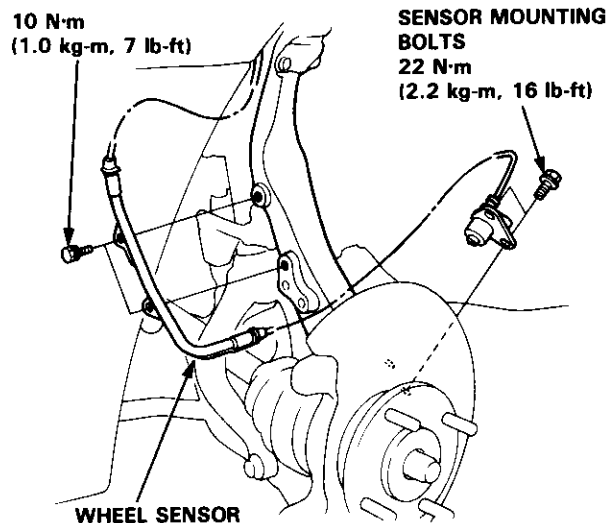

43. Install the brake disc with the 6 mm brake disc retaining screws.

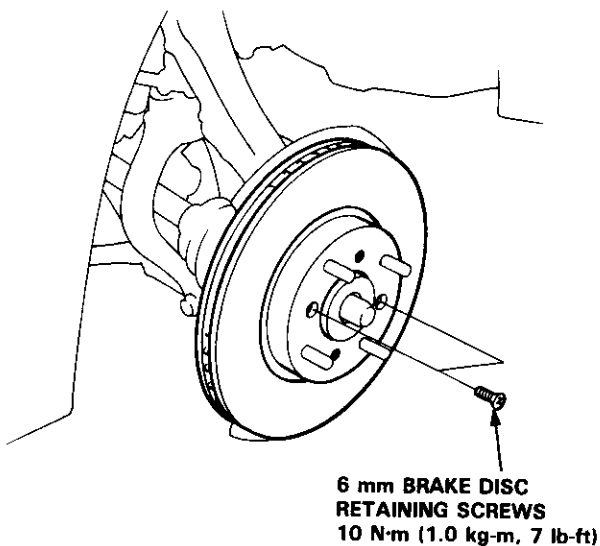

44. Install the brake caliper with the caliper bracket mounting bolts.

45. Install the brake hose with the brake hose mounting bolts.

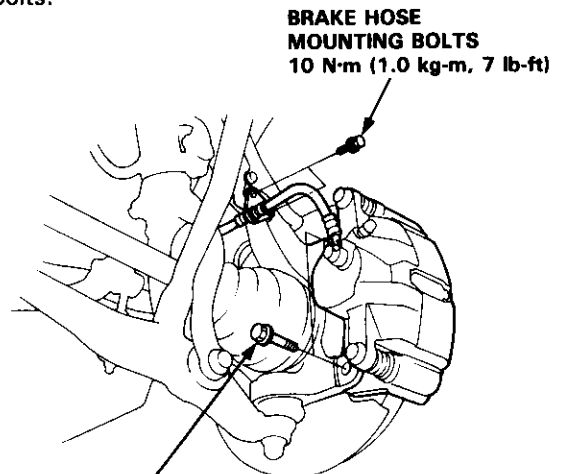

CALIPER BRACKET MOUNTING BOLTS
12 x 1.25 mm
110 N·m (11 kg-m, 80 lb-ft)

46. Tighten the new spindle nut.

NOTE: Before installing the wheel, clean the mating surface of the brake disc and inside of the wheel.

47. Install the wheel with the wheel lug nuts.

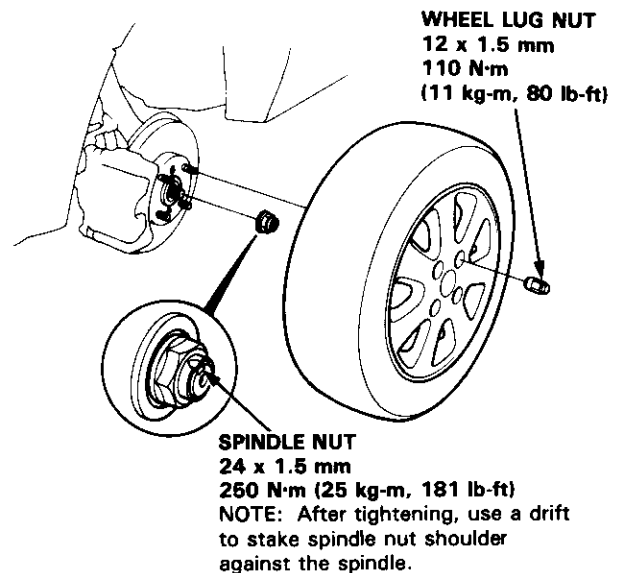

48. Check the front wheel alignment and adjust if necessary (see page 18-4).



Suspension Arms

Removal/Inspection

CAUTION:

- Replace the self-locking nuts after removal.
- Replace the self-locking bolts if you can easily thread a non-self-locking nut past their nylon locking inserts. (It should require 1 N·m (0.1 kg·m, 0.7 lb·ft) of torque to turn the nut on the bolt).
- Be careful not to damage the ball joint boots.

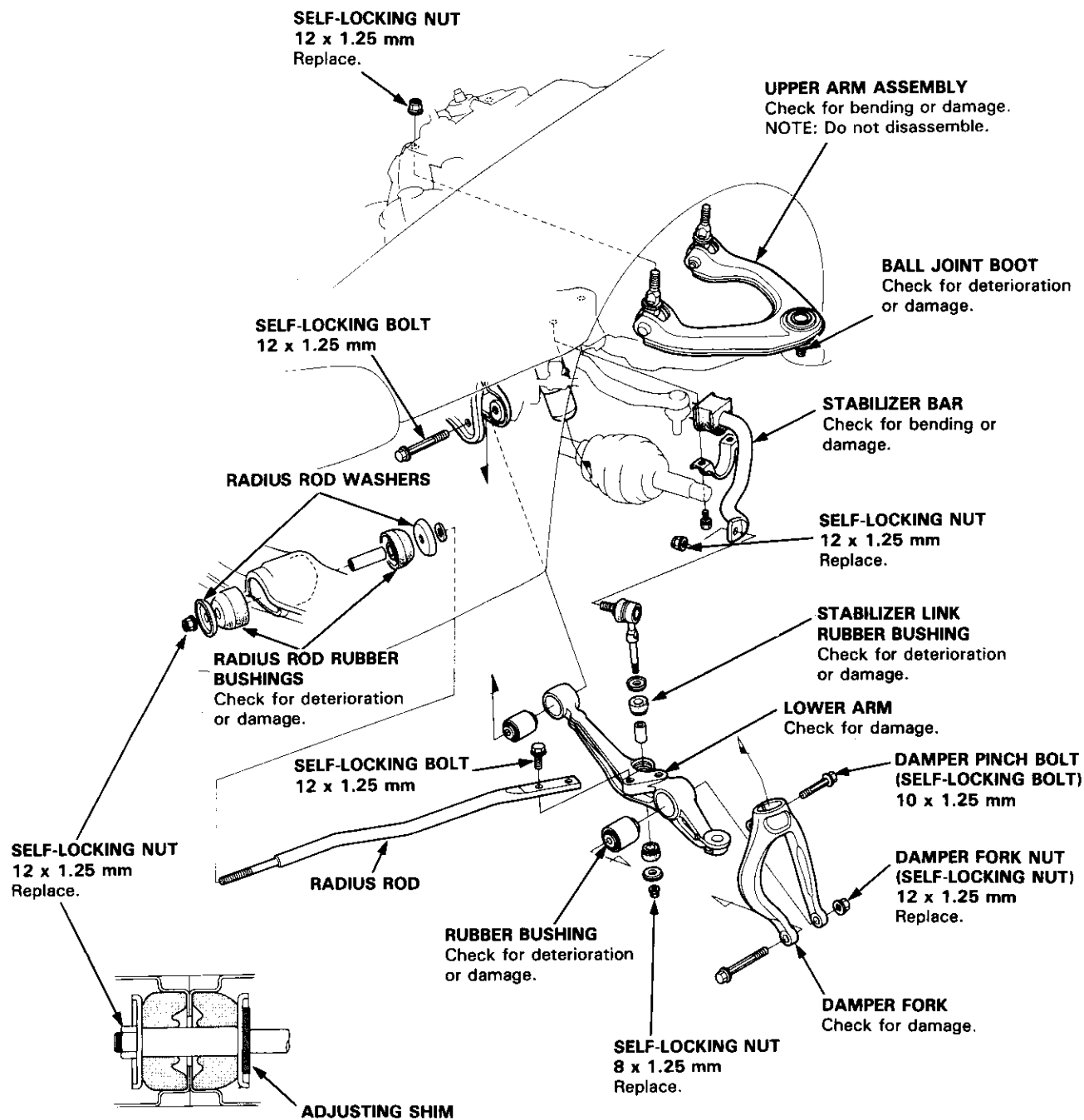

NOTE: Adjust the caster angle by increasing/decreasing the adjusting shims (see page 18-4).

Front Suspension

Suspension Arms (cont'd)

Installation

CAUTION: The vehicle should be on the ground before any bolts or nuts connected to rubber mounts or bushing are tightened.

NOTE:

- Wipe off the grease before tightening the nut at the ball joint.
- The right and left upper damper forks are not symmetrical. The left damper fork is marked with "SL" while the right damper fork is marked with "SR". Do not interchange them.
- The right and left upper arms are not symmetrical. The left upper arm is marked with "SL" while the right arm is marked with "SR". Do not interchange them.
- After installing the suspension arm, check the wheel alignment and adjust if necessary.
- When installing the radius rod washers, the "FR" mark faces the front of the car.

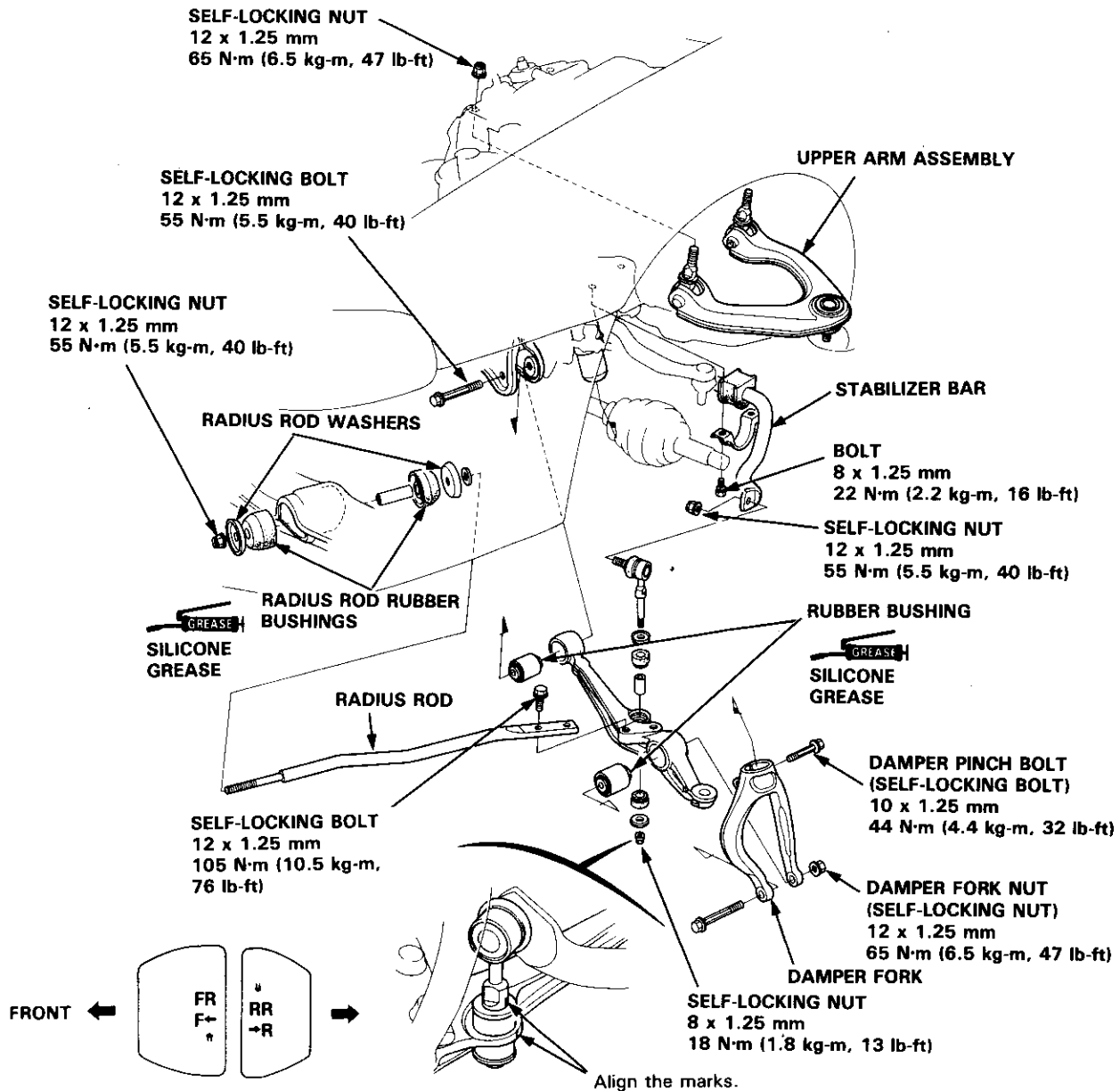

CAUTION: Do not interchange the radius rod rubber bushings.



Ball Joint Boot Replacement

1. Remove the set ring and the boot.

CAUTION: Do not contaminate the boot installation section with grease.

2. Pack the interior of the boot and lip with grease.

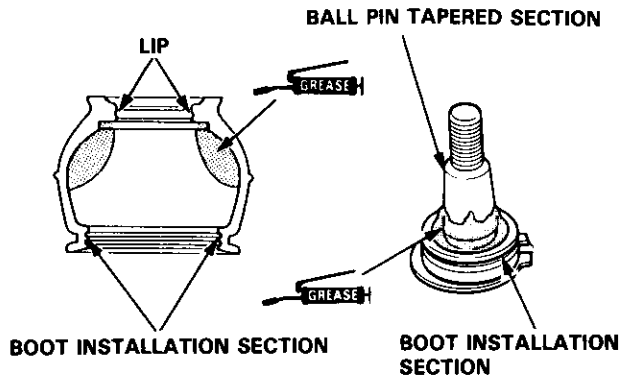

3. Wipe the grease off the sliding surface of the ball pin and pack with fresh grease.

CAUTION:

- Keep grease off the boot installation section and the tapered section of the ball pin.
- Do not allow dust, dirt, or other foreign materials to enter the boot.

4. Install the boot in the groove of the boot installation section securely, then bleed air.

5. Install the upper and lower ball joint boot clips using the special tools as follows:

Lower ball joint: Adjust the special tool with the adjusting bolt until the end of the tool aligns with the groove on the boot. Slide the set ring over the tool and into position.

Upper ball joint: Hold the tool over the ball joint, then slide the clip over the tool and into position.

**BALL JOINT
BOOT CLIP
GUIDE**

**UPPER BALL
JOINT BOOT:
07974-SA50800**

**LOWER BALL
JOINT BOOT:
07GAG-SD40700**

40 mm CIRCLIP

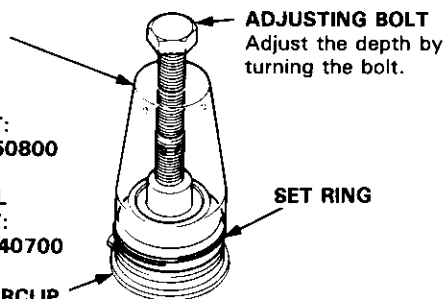

CAUTION: After installing the boot, check the ball pin tapered section for grease contamination and wipe it if necessary.

Lower Arm Bushing Replacement

Adjust the bushing driver so that it matches the outside dimension of the lower arm bushing. Press the lower arm bushing using the special tool and a press.

NOTE: When installing the lower arm bushing, press it so that its leading edges are flush with the lower arm.

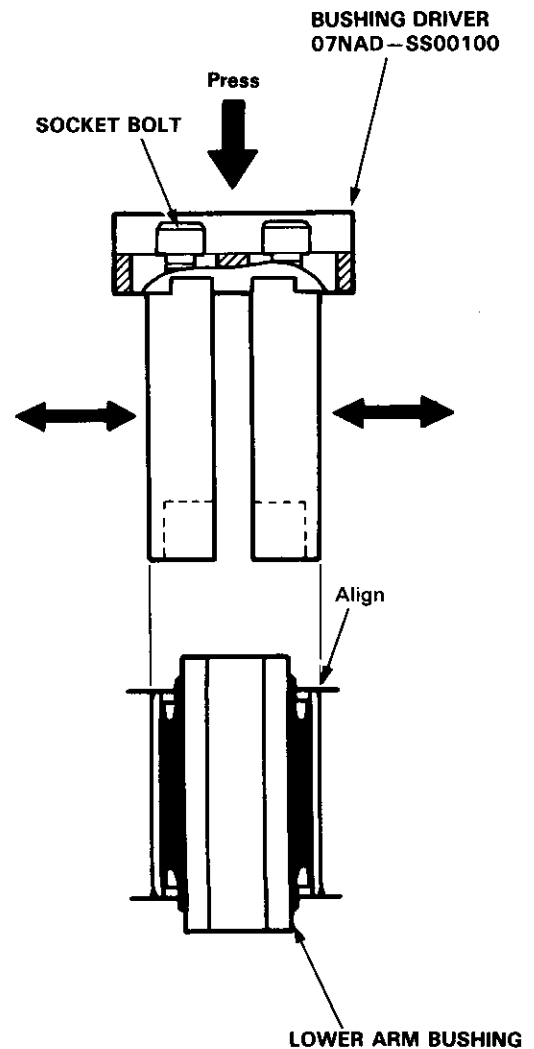

Front Damper

Removal

1. Remove the brake hose mounting bolts from the damper.
2. Remove the damper pinch bolt.
3. Remove the damper fork nut, bolt and remove the damper fork.

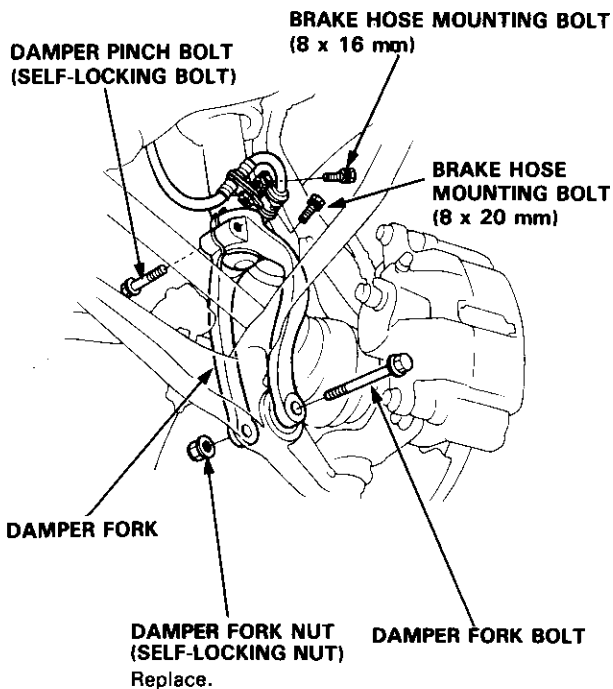

4. Remove the damper by removing the three nuts.

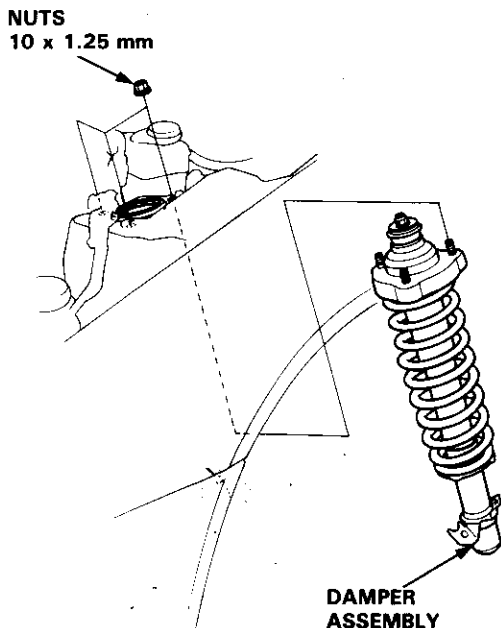

Disassembly/Inspection

Disassembly

1. compress the damper spring with the spring compressor according to the manufacturer's instructions, then remove the self-locking nut.

CAUTION: Do not compress the spring more than necessary to remove the nut.

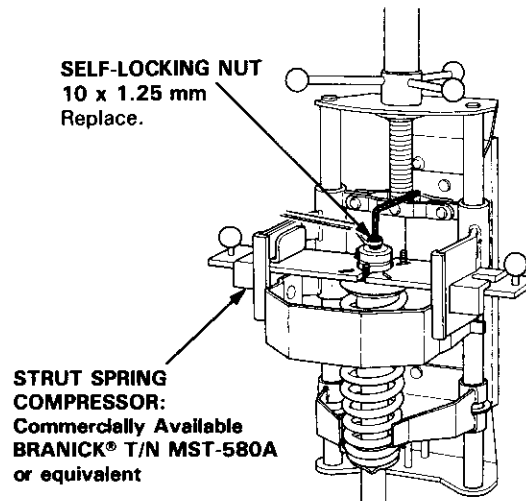

2. Remove the spring compressor then disassemble the damper as shown on the next page.

Inspection

1. Reassemble all parts, except the spring.
2. Push on the damper assembly as shown.
3. Check for smooth operation through a full stroke, both compression and extension.

NOTE: The damper should move smoothly. If it does not (no compression or no extension), the gas is leaking, and the damper should be replaced.

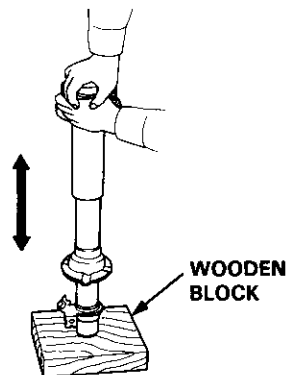

4. Check for oil leaks, abnormal noises or binding during these tests.

NOTE: See page 18-41 for damper disposal.



Inspection

SELF-LOCKING NUT
10 x 1.25 mm
30 N·m (3.0 kg-m, 22 lb-ft)
Replace.

DAMPER MOUNTING WASHER
Check for weakness.

DAMPER MOUNTING RUBBER

DAMPER MOUNTING COLLAR

DAMPER SPRING
Check for weakened compression or damage.

DAMPER MOUNTING BASE

DAMPER MOUNTING RUBBER

BUMP STOP PLATE

BUMP STOP
Check for weakness or damage.

SPRING MOUNTING RUBBER
Check for damage.

DUST COVER PLATE

DUST COVER
Check for bending or damage.

DAMPER UNIT
• Check for leaks and faulty operation.
• Check for rust.

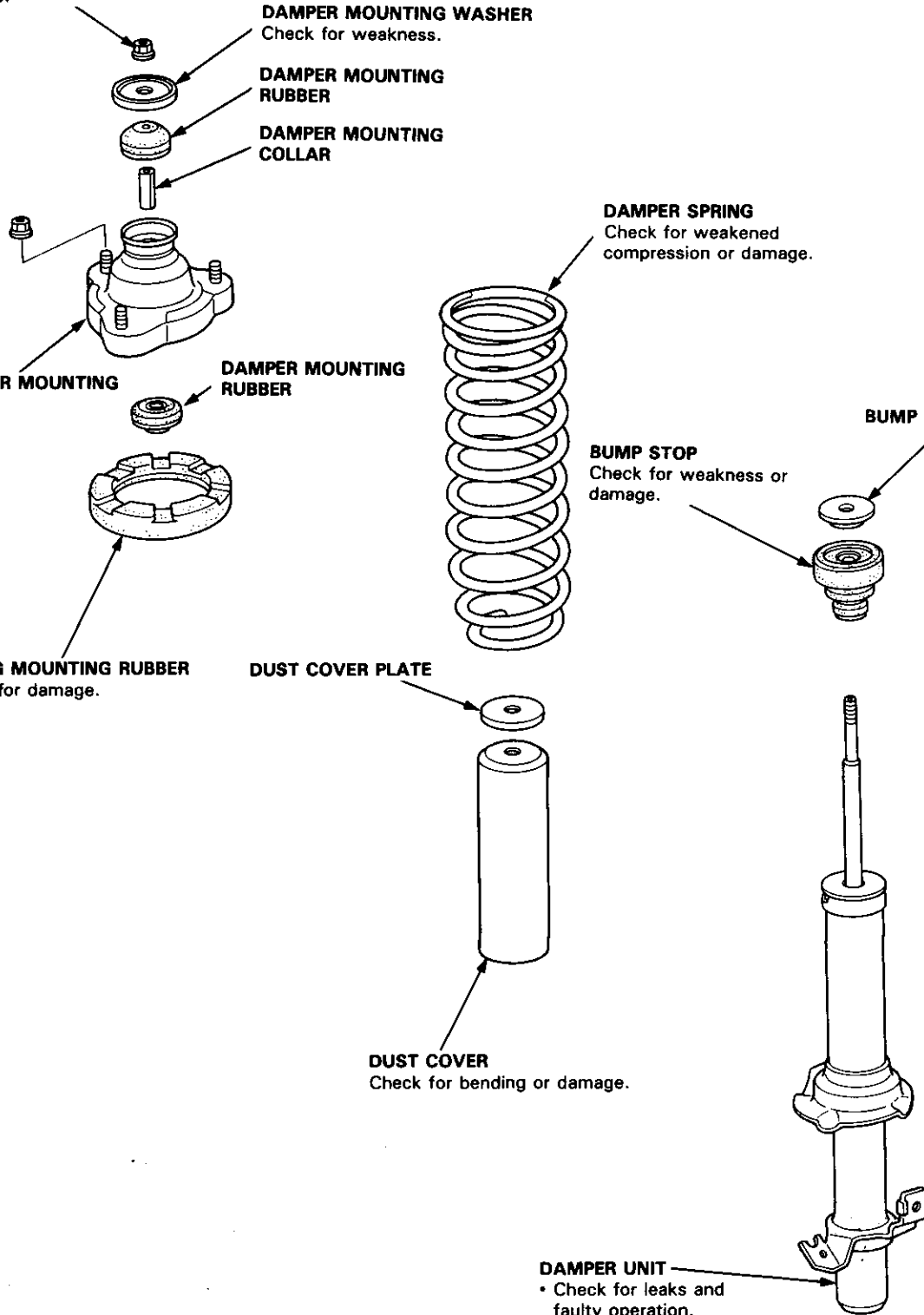

Front Damper

Reassembly

1. Install the damper unit on a spring compressor.

NOTE: Follow the manufacturer's instructions.

2. Assemble the damper in reverse order of disassembly except the damper mounting washer and self-locking nut.

NOTE: Align the bottom of the damper spring with the spring lower seat as shown.

3. Position the damper mounting base on the damper unit as shown.

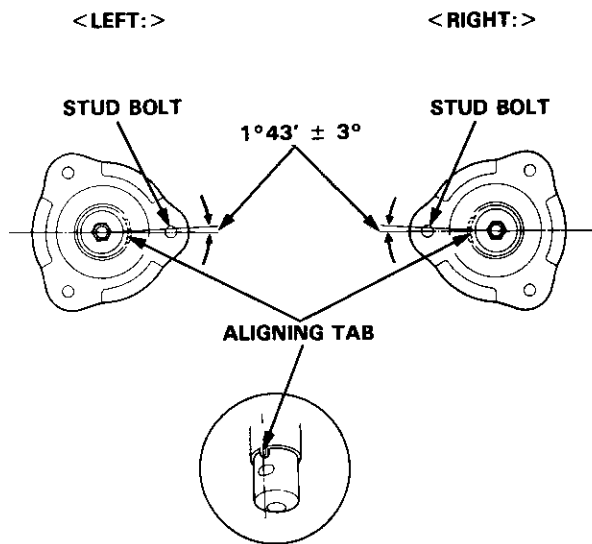

STRUT SPRING COMPRESSOR:
Commercially Available
BRANICK® T/N MST-580A
or equivalent

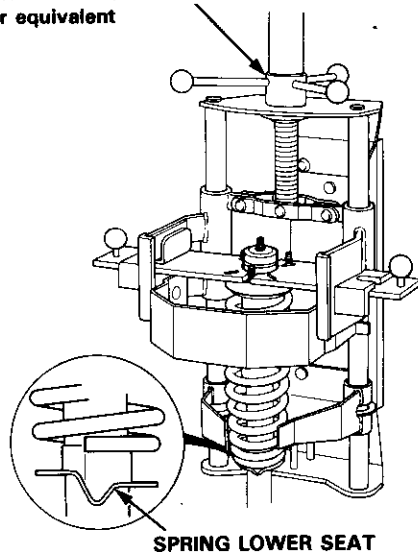

4. Compress the damper spring with the spring compressor.

CAUTION: Do not compress the spring more than necessary to install the nut.

5. Install the damper mounting washer, then loosely install the new self-locking nut.
6. Hold the damper shaft and tighten the new self-locking nut.

SELF-LOCKING NUT
10 x 1.25 mm
30 N·m (3.0 kg·m, 22 lb·ft)

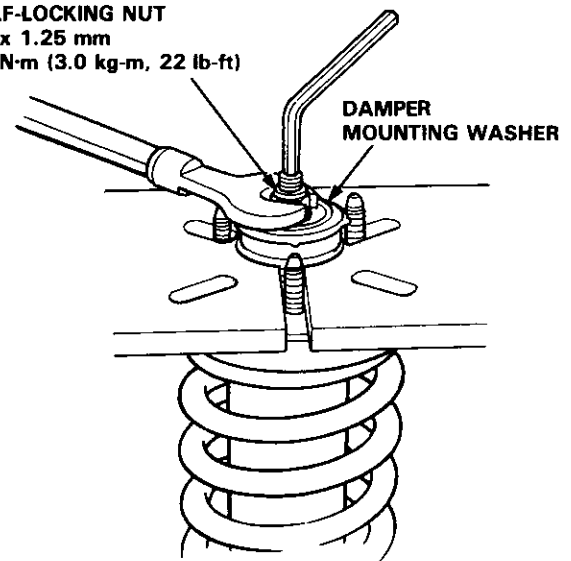



Installation

1. Loosely install the damper on the frame with the aligning tab facing inside.

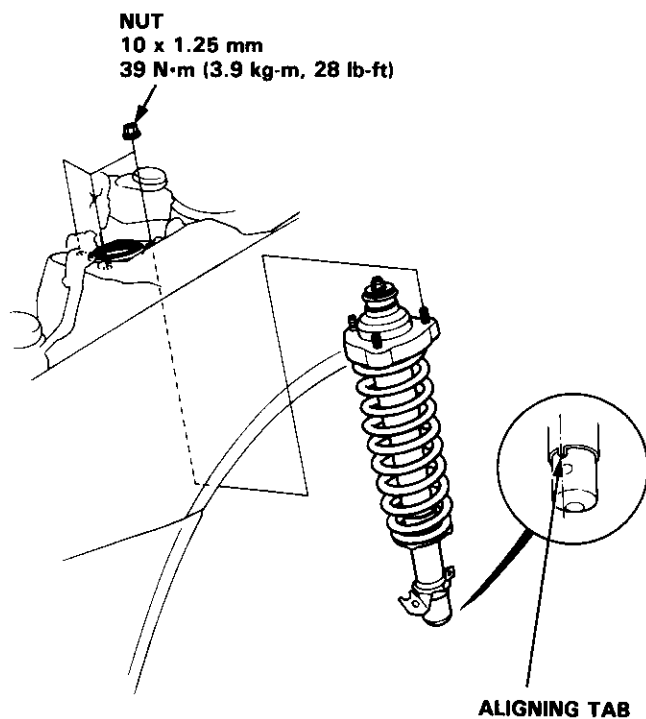

2. Install the damper fork over the driveshaft and onto the lower arm. Install the damper in the damper fork so the aligning tab is aligned with the slot in the damper fork.

3. Hand-tighten the bolts and nuts.

4. Raise the knuckle with a floor jack until the car just lifts off the safety stand.

NOTE: The bolts and nuts should be tightened with the vehicle's weight on the damper.

5. Tighten the damper pinch bolt.
6. Secure the damper fork bolt with a new self-locking nut.
7. Secure the damper assembly to the frame with the flange nuts.
8. Install the brake hose mounting bolts.

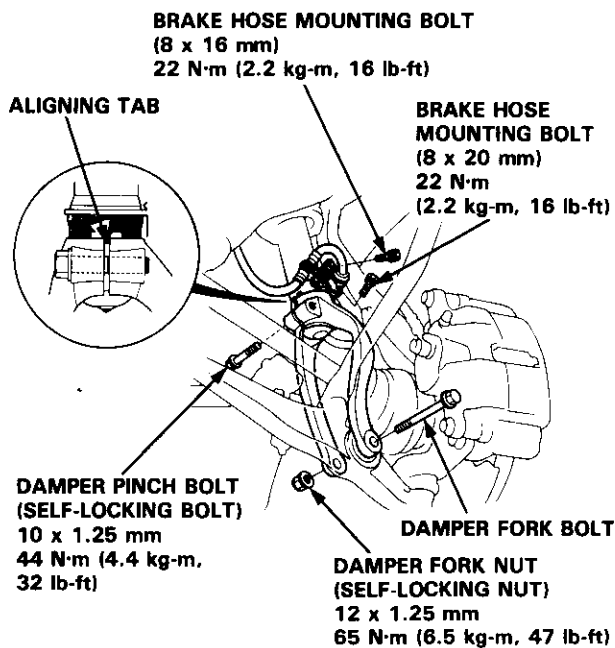

Rear Suspension

Torque Specifications

CAUTION:

- Replace the self-locking nuts after removal.
- Replace the self-locking bolts if you can easily thread a non-self-locking nut past their nylon locking inserts. (It should require 1 N·m (0.1 kg-m, 0.7 lb-ft) of torque to turn the nut on the bolt).
- The vehicle should be on the ground before any bolts or nuts connected to rubber mounts or bushings are tightened.
- Torque the castle nut to the lower torque specification, then tighten it only far enough to align the slot with the pin hole. Do not align the nut by loosening.

NOTE: Wipe off the grease before tightening the nut at the ball joint.

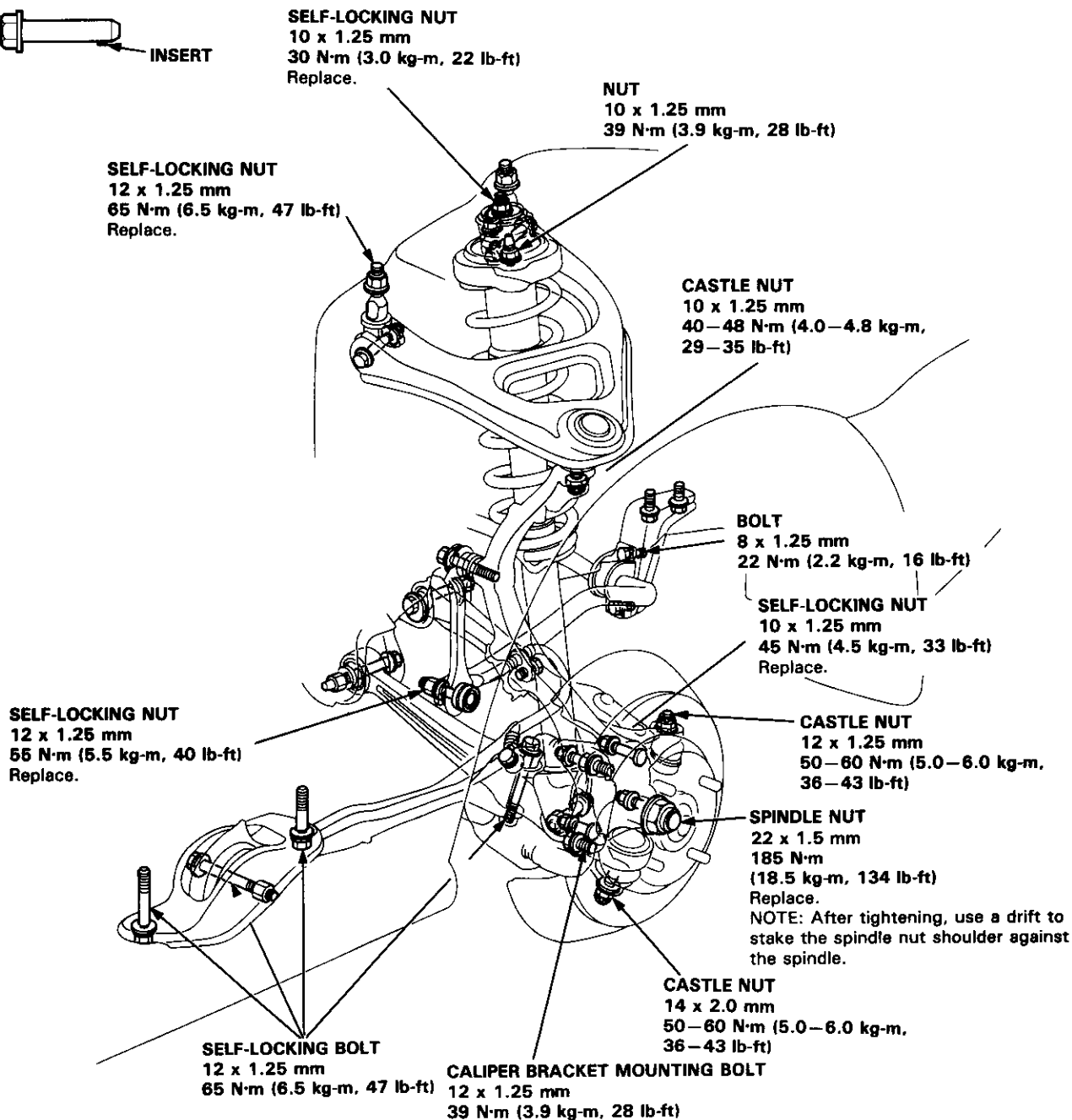



Knuckle/Hub

Illustrated Index

NOTE:

- Use only genuine Honda wheel weights for aluminum wheels. Non-genuine wheel weights may corrode and damage the aluminum wheels.
- Before installing the brake disc, clean the mating surfaces of the rear hub and inside of the brake disc.
- Before installing the wheel, clean the mating surfaces of the brake disc and inside of the wheel.

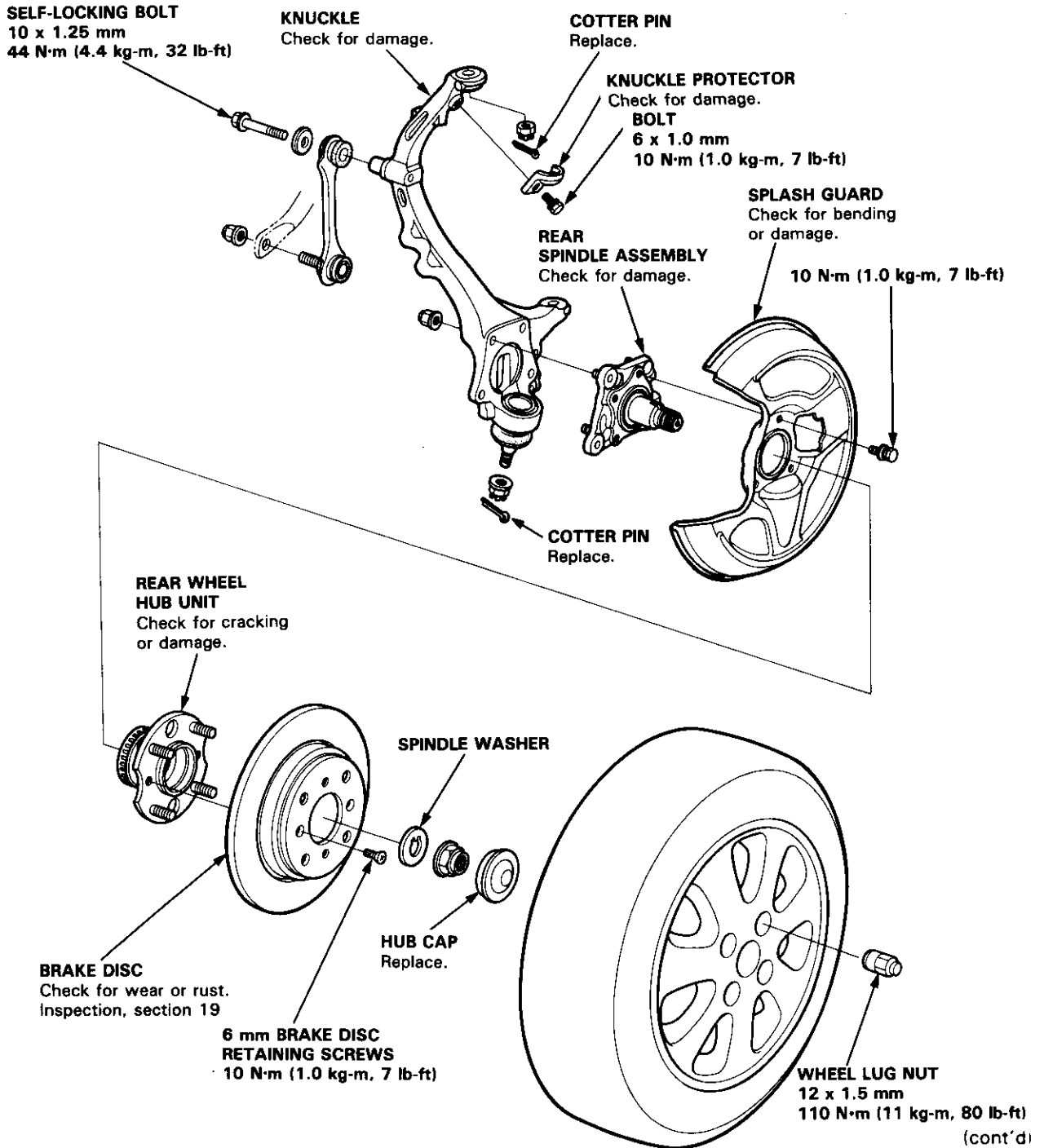

Rear Suspension

Knuckle/Hub (cont'd)

Removal

1. Loosen the wheel nuts slightly.
2. Raise the rear of car and support it with safety stands in proper locations (see section 1).
3. Remove the wheel lug nuts and rear wheel.
4. Pull the parking brake lever up.
5. Remove the hub cap, then raise the locking tab on the spindle nut, then remove the nut.

HUB CAP

Replace.

NOTE: Take care not to damage the hub unit on disassembly.

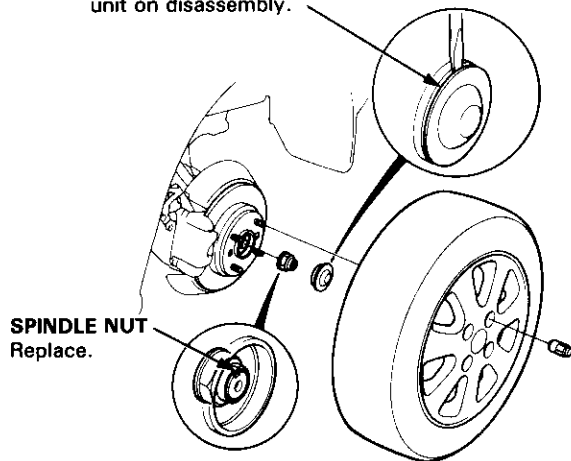

6. Remove the brake hose mounting bolts.
7. Remove the caliper bracket mounting bolts and hang the caliper assembly to one side.

CAUTION: To prevent accidental damage to the caliper assembly or brake hose, use a short piece of wire to hang the caliper assembly from the undercarriage.

BRAKE HOSE MOUNTING BOLT

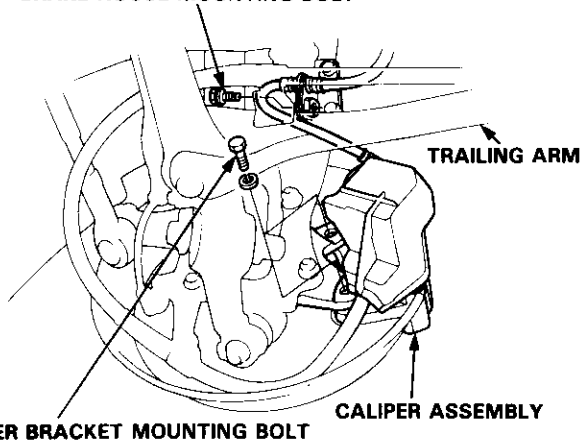

8. Remove the 6 mm brake disc retaining screws.
9. Screw two 8 x 1.25 mm bolts into the disc to push it away from the hub.

NOTE: Turn each bolt two turns at a time to prevent cocking the disc excessively.

10. Remove the brake disc.

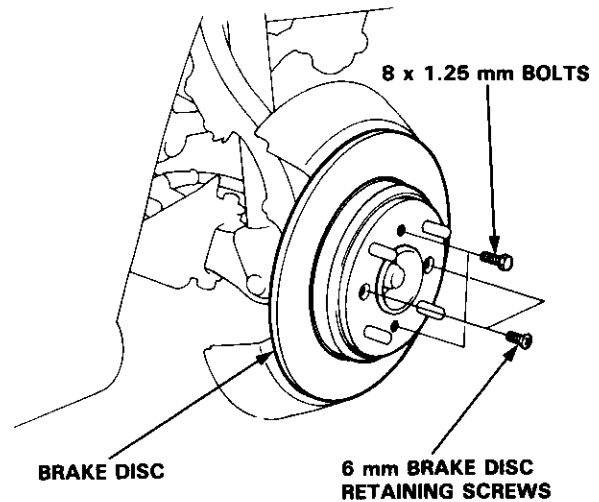

11. Remove the hub unit from the knuckle.

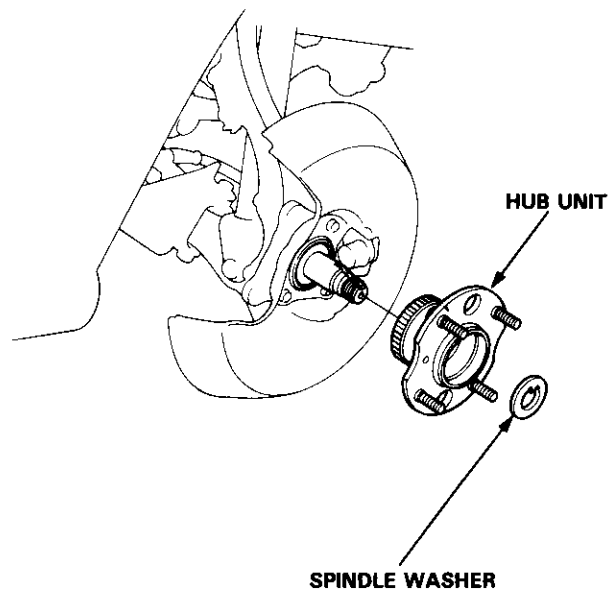



12. Remove the splash guard from the knuckle.

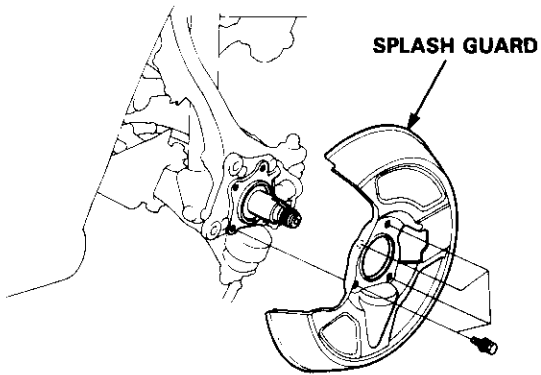

13. Remove the parking brake cable from the knuckle.

14. Remove the wheel sensor wire bracket, then remove the wheel sensor from the knuckle.

NOTE: Do not disconnect the wheel sensor wire.

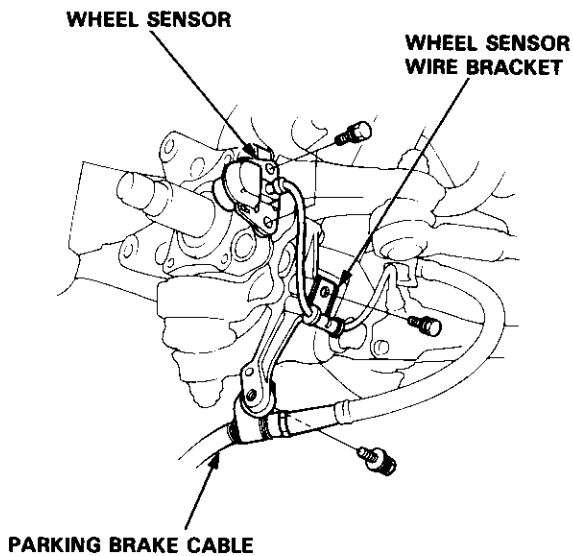

15. Remove the rear spindle assembly from the knuckle.

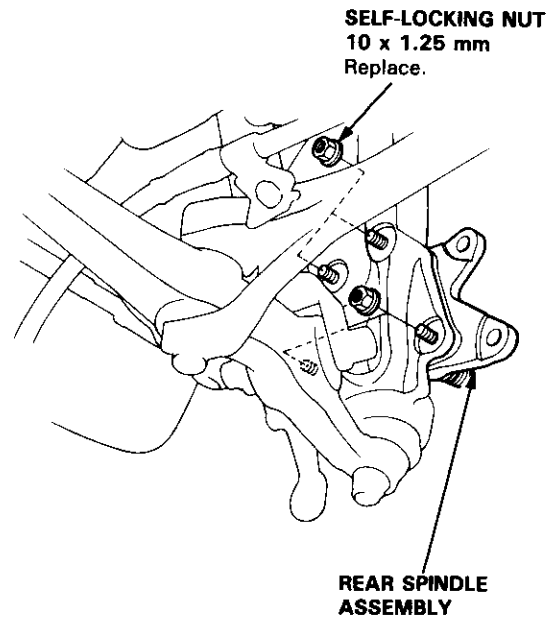

16. Hold the ball pin of the stabilizer link with a hex wrench and loosen the self-locking nut.

17. Remove the self-locking nut, then disconnect the stabilizer link from the stabilizer bar.

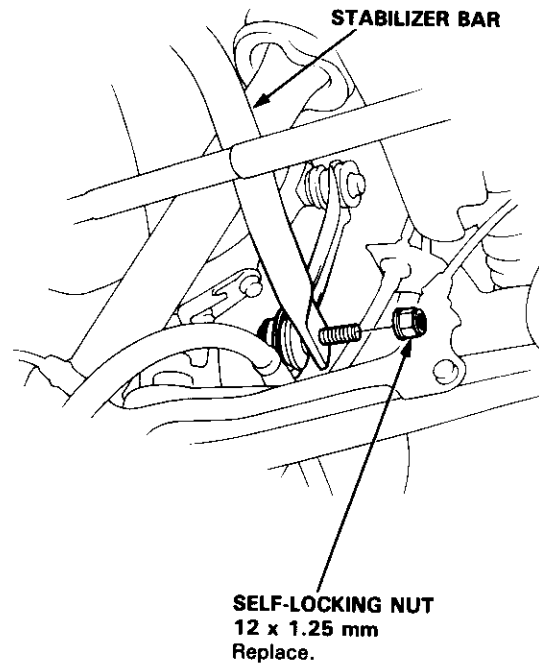

(cont'd)

Rear Suspension

Knuckle/Hub (cont'd)

18. Remove the cotter pin from the tie-rod end (4WS) or lower arm B (2WS) and remove the castle nut.
19. Install a 12 mm hex nut on the ball joint. Be sure that the hex nut is flush with the ball joint pin end, or the threaded section of the ball joint pin might be damaged by the ball joint remover.
20. Use the ball joint remover as shown on page 18-13 to separate the ball joint and knuckle.

NOTE: If necessary, apply penetrating type lubricant to loosen the ball joint.

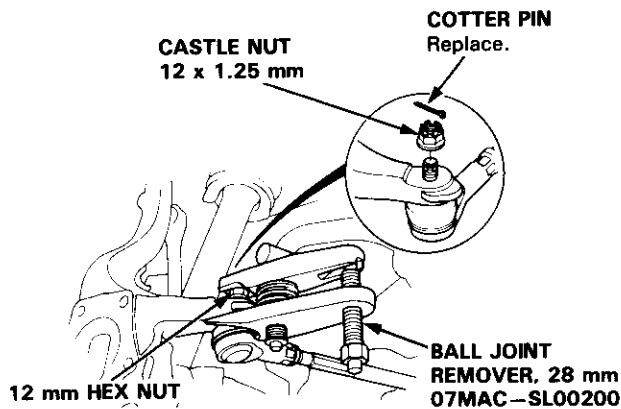

21. Remove the cotter pin and lower arm ball joint nut.
22. Install a 14 mm hex nut on the ball joint. Be sure that the hex nut is flush with the ball joint pin end, or the threaded section of the ball joint pin might be damaged by the ball joint remover.
23. Use the ball joint remover as shown on page 18-13 to separate the ball joint and lower arm.

NOTE: If necessary, apply penetrating type lubricant to loosen the ball joint.

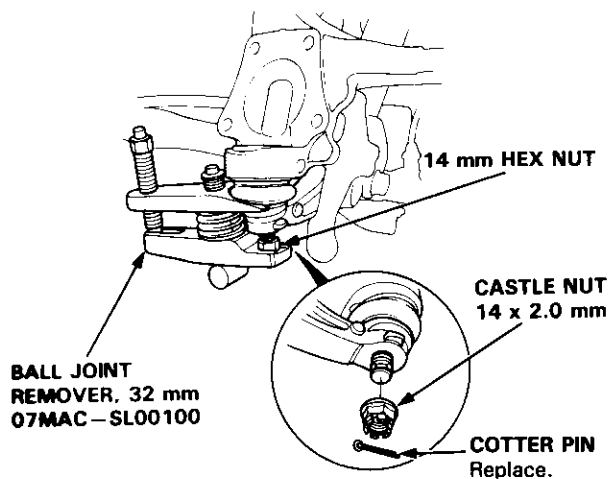

24. Remove the knuckle protector.
25. Remove the cotter pin and the upper ball joint nut.
26. Install a 10 mm hex nut on the ball joint. Be sure that the hex nut is flush with the ball joint pin end, or the threaded section of the ball joint pin might be damaged by the ball joint remover.
27. Use the ball joint remover as shown on page 18-13 to separate the ball joint and knuckle, then remove the knuckle.

NOTE: If necessary, apply penetrating type lubricant to loosen the ball joint.

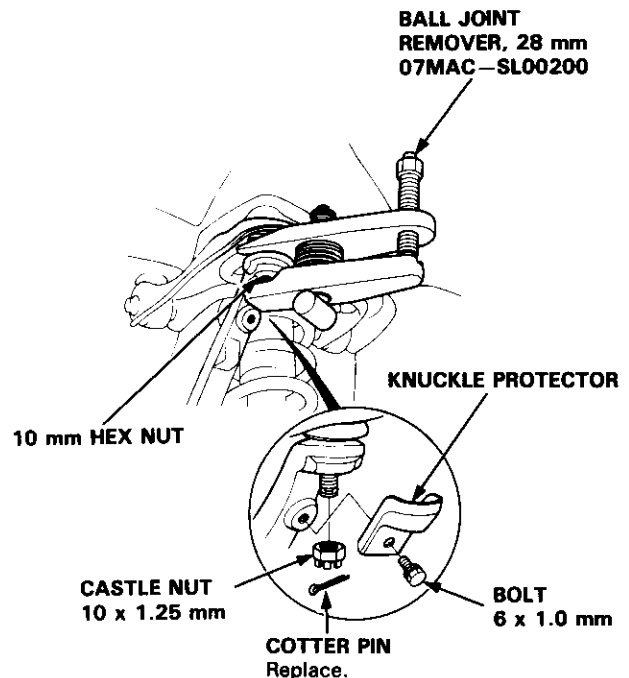



Installation

28. Connect the lower arm, lower arm B (2WS) or tie-rod end (4WS) and upper arm with the knuckle, then tighten the castle nuts.
29. Install the new cotter pins.
30. Install the knuckle protector with the bolt.
31. Connect the knuckle and the stabilizer bar, then tighten the new self-locking nut.

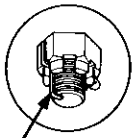

COTTER PIN
On reassembly, bend the cotter pin as shown.

SELF-LOCKING NUT
12 x 1.25 mm
55 N·m (5.5 kg-m, 40 lb-ft)

CASTLE NUT
14 x 2.0 mm
50–60 N·m (5.0–6.0 kg-m,
36–43 lb-ft)

COTTER PIN

CASTLE NUT
12 x 1.25 mm
50–60 N·m (5.0–6.0 kg-m,
36–43 lb-ft)

32. Install the rear spindle assembly on the knuckle, then tighten the new self-locking nuts.

SELF-LOCKING NUTS
10 x 1.25 mm
45 N·m (4.5 kg-m, 33 lb-ft)

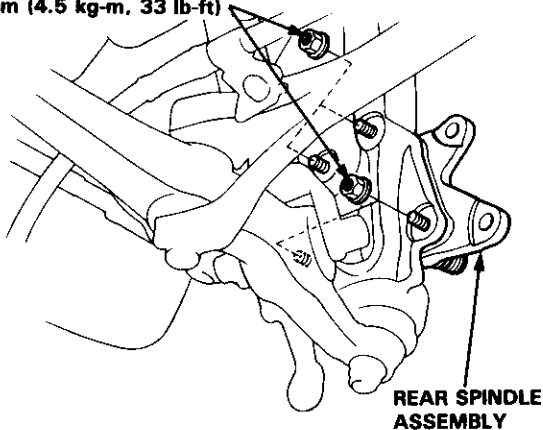

33. Install the wheel sensor, wheel sensor wire bracket and parking brake cable on the knuckle.

NOTE: Be careful when installing the sensor to avoid twisting the wire.

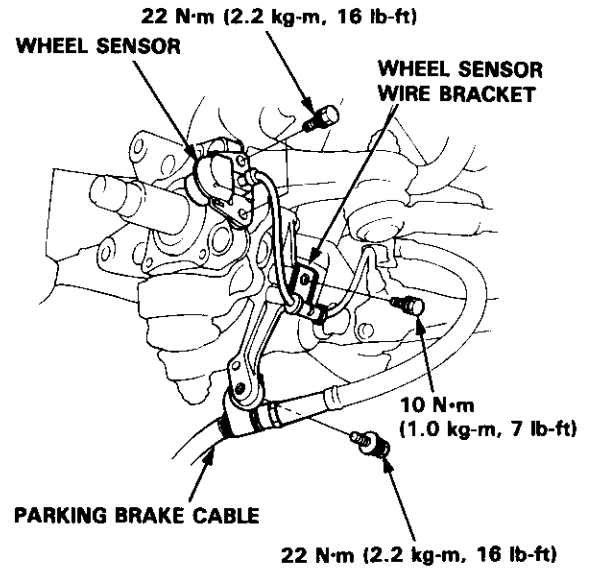

34. Install the splash guard with the bolts.

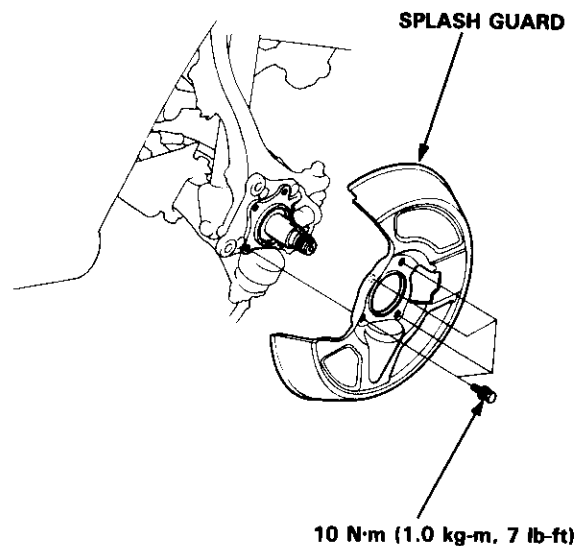

(cont'd)

Rear Suspension

Knuckle/Hub (cont'd)

35. Install the hub unit and spindle washer on the knuckle.

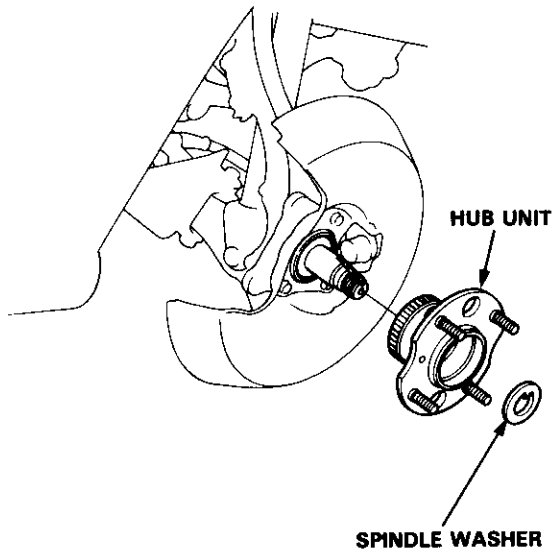

36. Install the brake disc with the 6 mm brake disc retaining screws.

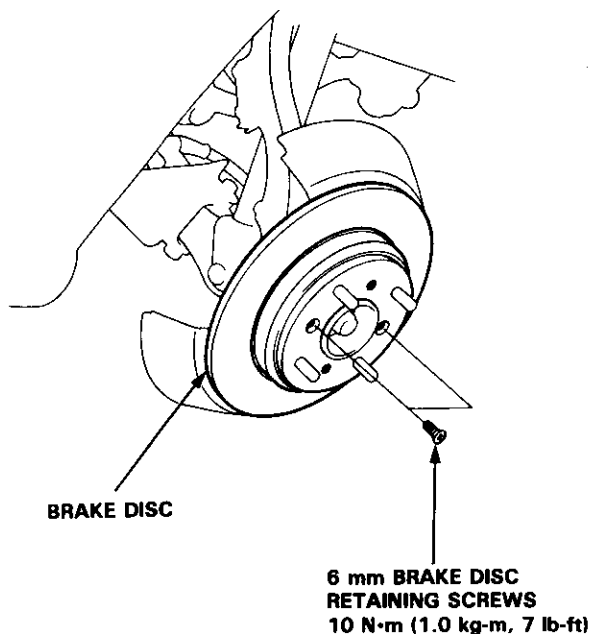

37. Install the caliper assembly with the caliper bracket mounting bolts.

38. Install the brake hose with the brake hose mounting bolts.

BRAKE HOSE MOUNTING BOLT
22 N·m (2.2 kg-m, 16 lb-ft)

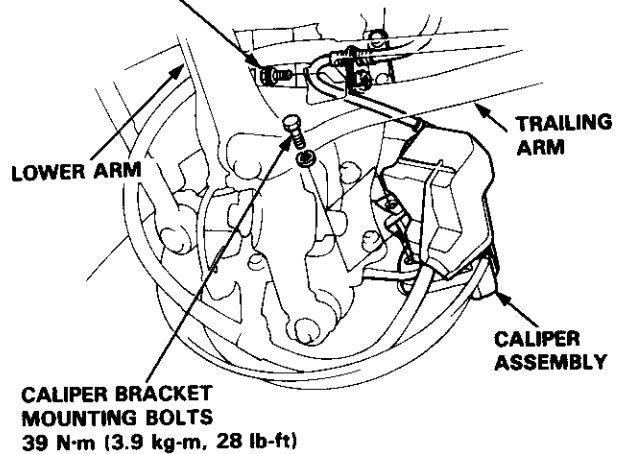

CALIPER BRACKET MOUNTING BOLTS
39 N·m (3.9 kg-m, 28 lb-ft)

39. Install the new spindle nut, then tighten the nut.

40. Install the new hub cap.

41. Install the rear wheel with the wheel lug nuts.

NOTE: Before installing the wheel, clean the mating surface of the brake disc and inside of the wheel.

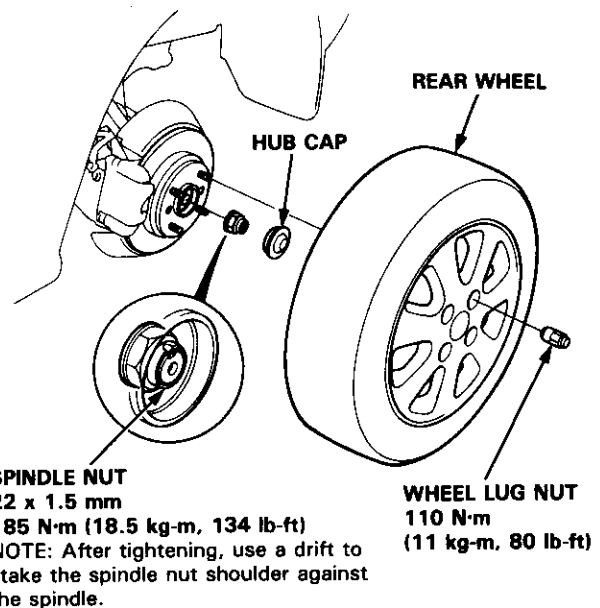

SPINDLE NUT
22 x 1.5 mm
185 N·m (18.5 kg-m, 134 lb-ft)
NOTE: After tightening, use a drift to stake the spindle nut shoulder against the spindle.

WHEEL LUG NUT
110 N·m
(11 kg-m, 80 lb-ft)

42. Check the rear wheel alignment and adjust if necessary (see page 18-4).



Suspension Arms

Removal/Inspection

CAUTION:

- Replace the self-locking nuts after removal.
- Replace the self-locking bolts if you can easily thread a non-self-locking nut past their nylon locking inserts. (It should require 1 N·m (0.1 kg-m, 0.7 lb-ft) of torque to turn the nut on the bolt).
- Be careful not to damage the ball joint boots.

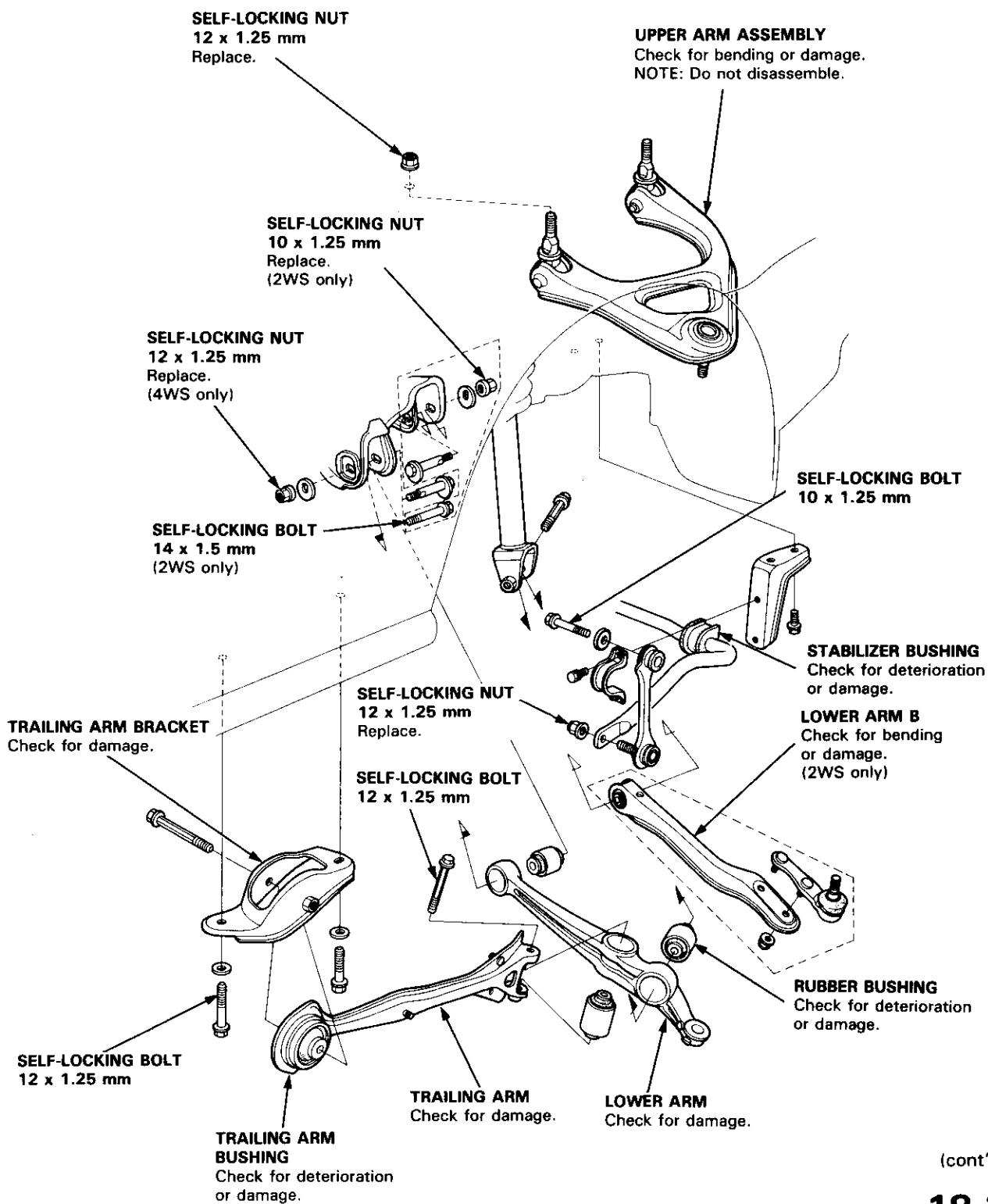

(cont'd)

Rear Suspension

Suspension Arms (cont'd)

Installation

CAUTION: The vehicle should be on the ground before any bolts or nuts connected to rubber mounts or bushing are tightened.

NOTE:

- Wipe off the grease before tightening the nut at the ball joint.
- The right lower arm B is identified by white paint.
- The right and left upper arms are not symmetrical. The left upper arm is marked with "L" while the right arm is marked with "R". Do not interchange them.
- After installing the suspension arm, check the wheel alignment and adjust if necessary.

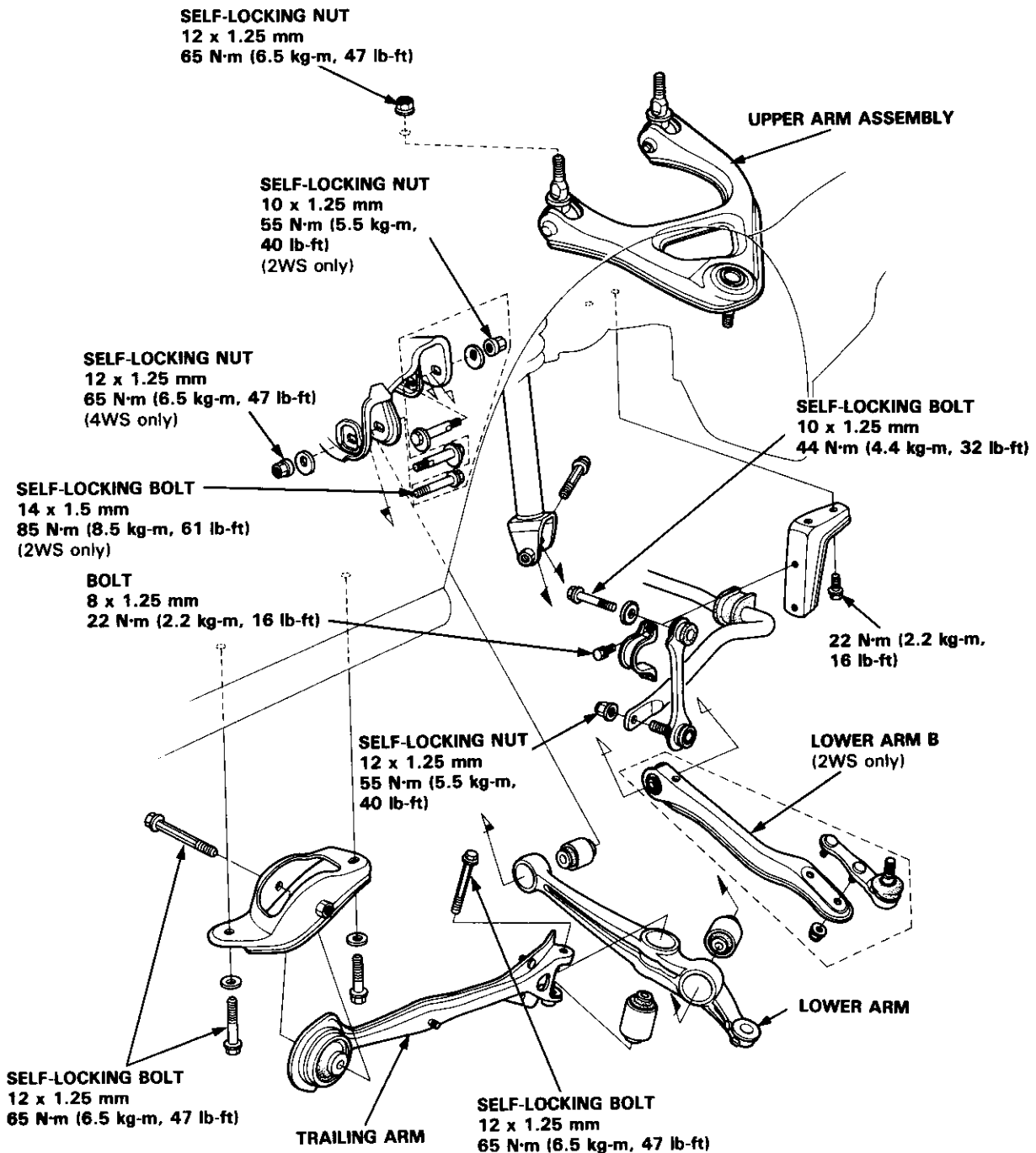



Ball Joint Boot Replacement

1. Remove the set ring and the boot.

CAUTION: Do not contaminate the boot installation section with grease.

2. Pack the interior of the boot and lip with grease.

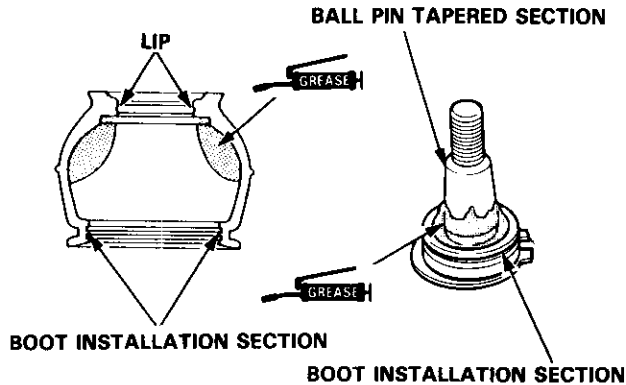

3. Wipe the grease off the sliding surface of the ball pin and pack with fresh grease.

CAUTION:

- Keep grease off the boot installation section and the tapered section of the ball pin.
- Do not allow dust, dirt, or other foreign materials to enter the boot.

4. Install the boot in the groove of the boot installation section securely, then bleed air.

5. Install the upper and lower ball joint boot clips using the special tools as follows:

Lower ball joint: Adjust the special tool with the adjusting bolt until the end of the tool aligns with the groove on the boot. Slide the set ring over the tool and into position.

Upper ball joint: Hold the tool over the ball joint, then slide the clip over the tool and into position.

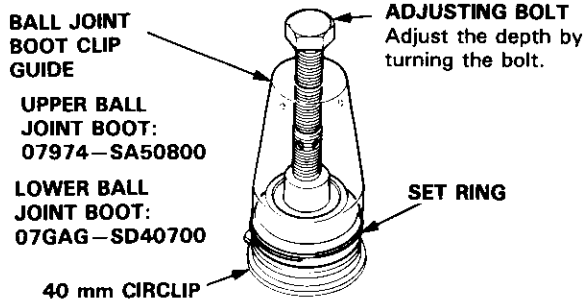

CAUTION: After installing the boot, check the ball pin tapered section for grease contamination and wipe it if necessary.

Lower Arm Bushing Replacement

Adjust the bushing driver so that it matches the outside dimension of the lower arm bushing. Press the lower arm bushing using the special tool and a press.

NOTE: When installing the lower arm bushing, press it so that its leading edges are flush with the lower arm.

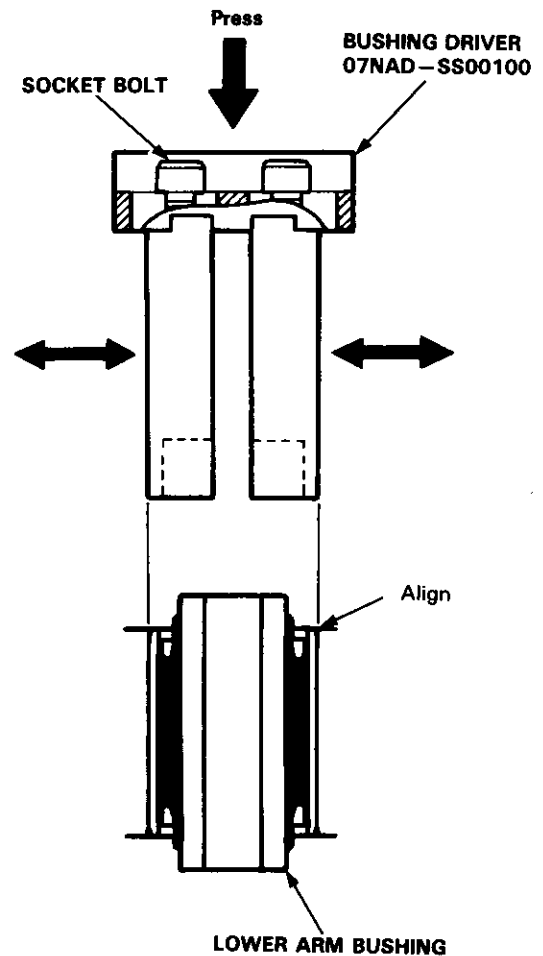

Rear Damper

Removal

1. Jack up the rear of car and support on safety stands in proper locations (see section 1).
2. Remove the rear wheel.
3. Remove the trunk side trim.
4. Remove the two nuts.

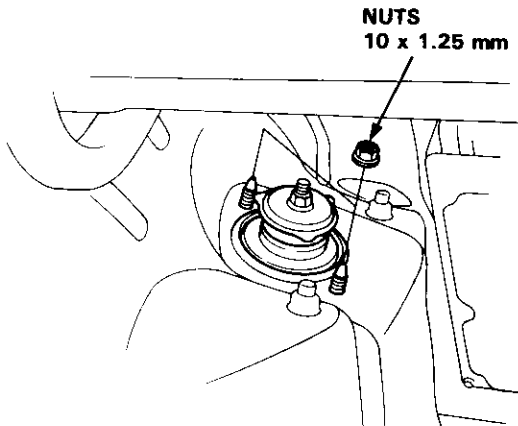

5. Remove the knuckle protector.
6. Remove the cotter pin and the upper ball joint nut.
7. Install a 10 mm hex nut on the ball joint. Be sure that the hex nut is flush with the ball joint pin end, or the threaded section of the ball joint pin might be damaged by the ball joint remover.
8. Use the ball joint remover as shown on page 18-13 to separate the ball joint and knuckle.

NOTE: If necessary, apply penetrating type lubricant to loosen the ball joint.

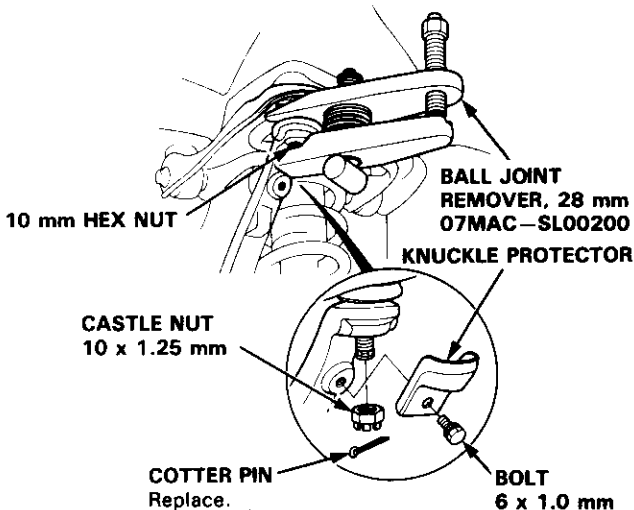

9. Remove the damper mounting bolt.
10. Lower the rear suspension and remove the damper assembly.

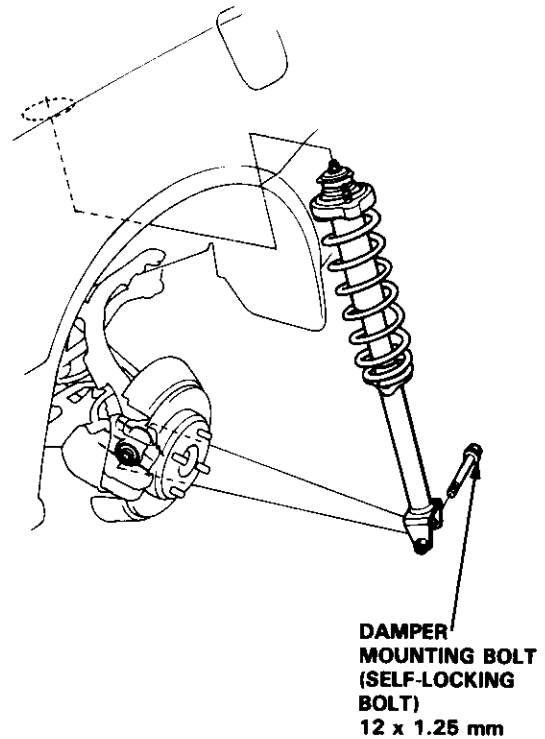



Disassembly

1. Compress the damper spring with the spring compressor according to the manufacturer's instructions.

CAUTION: Do not compress the spring more than necessary to remove the self-locking nut.

2. Remove the self-locking nut from the damper assembly.

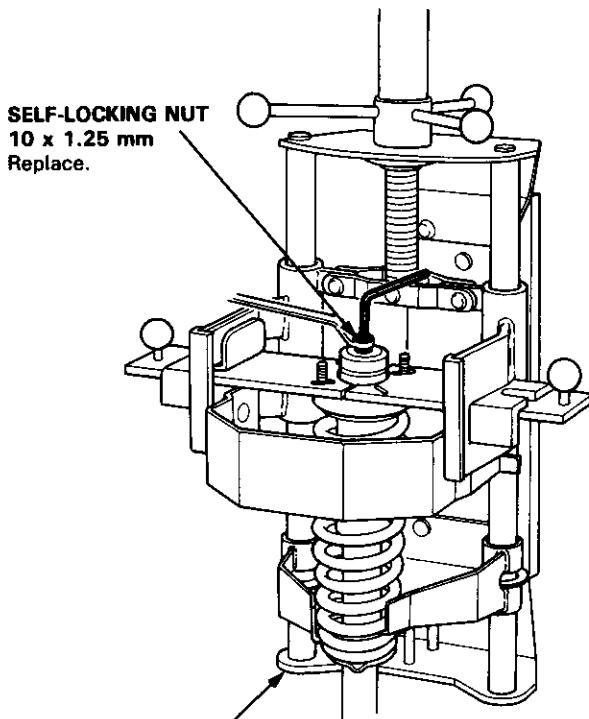

STRUT SPRING COMPRESSOR:
Commercially Available
BRANICK® T/N MST-580A
or equivalent

3. Remove the spring compressor and disassembly the damper as shown on the next page.

Inspection

1. Reassemble all parts, except the spring.
2. Push on the damper assembly as shown.
3. Check for smooth operation through a full stroke, both compression and extension.

NOTE: The damper should move smoothly. If it does not (no compression or no extension), the gas is leaking, and the damper should be replaced.

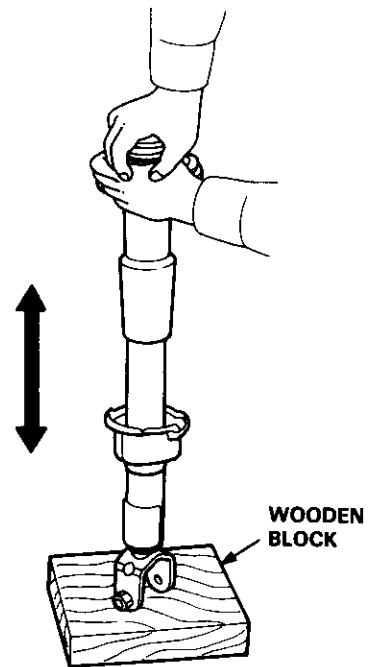

4. Check for oil leaks, abnormal noises or binding during these tests.

NOTE: See page 18-41 for damper disposal.

(cont'd)

Rear Damper

Inspection (cont'd)

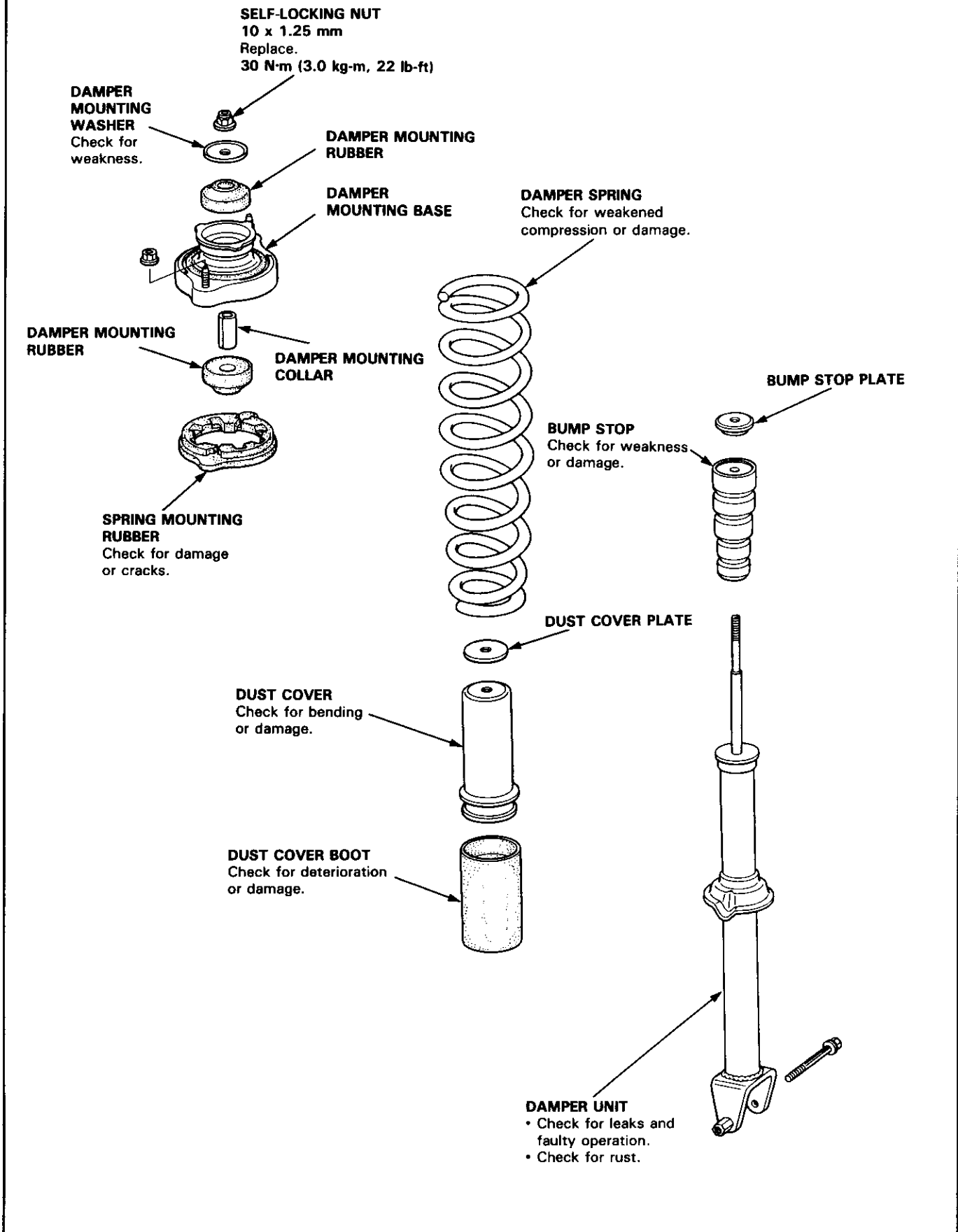



Reassembly

1. Install the damper unit on a spring compressor.

NOTE: Follow the manufacturer's instructions.

2. Assemble the damper in reverse order of disassembly except the damper mounting washer and self-locking nut.

NOTE: Align the bottom of the damper spring with the spring lower seat as shown.

3. Position the damper mounting base on the damper unit as shown.

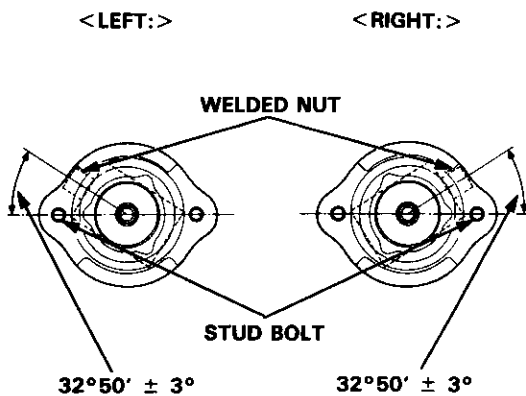

STRUT SPRING COMPRESSOR:
Commercially Available
BRANICK® T/N MST-580A
or equivalent

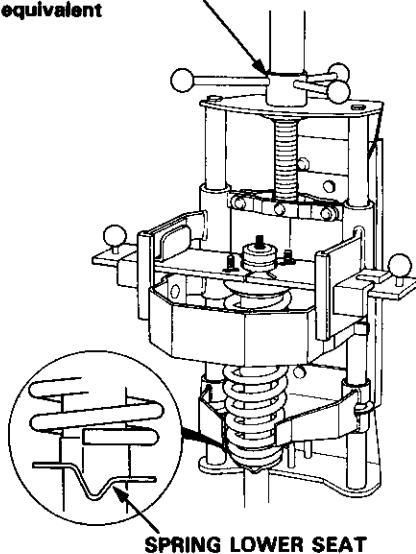

4. Compress the damper spring with the spring compressor.

CAUTION: Do not compress the spring more than necessary to install the nut.

5. Install the damper mounting washer, then loosely install the new self-locking nut.
6. Hold the damper shaft and tighten the self-locking nut.

SELF-LOCKING NUT
10 x 1.25 mm
30 N·m (3.0 kg·m, 22 lb·ft)

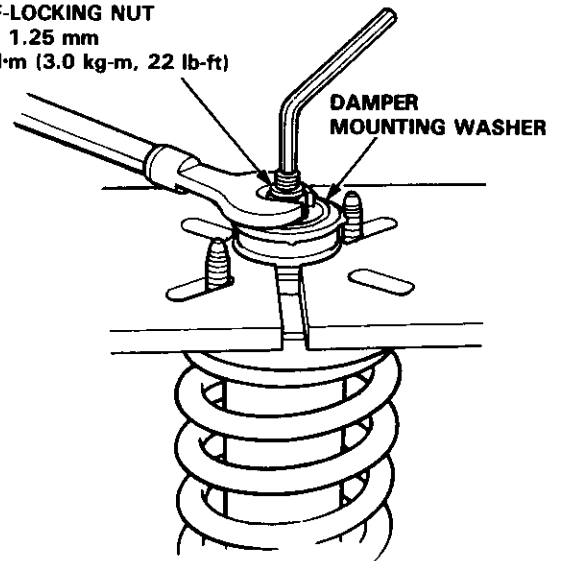

Rear Damper

Installation

1. Lower the rear suspension and set the damper assembly.
2. Connect the damper assembly and the lower arm, then loosely install the damper mounting bolt.

NOTE: The damper mounting bolt should be tightened with the damper under vehicle load.

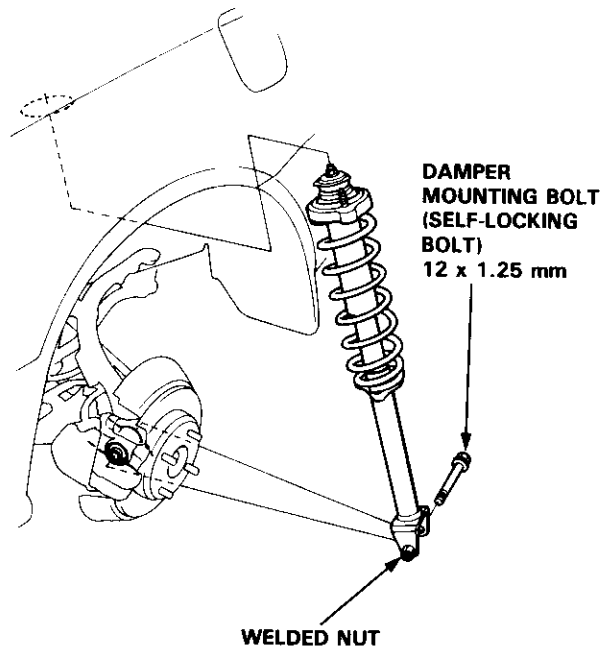

3. Tighten the two nuts.

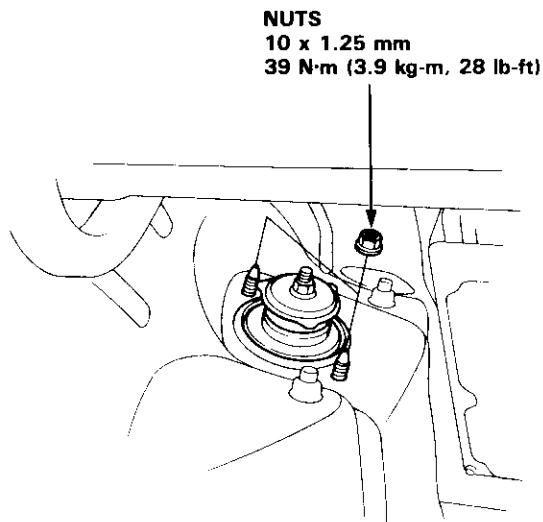

4. Connect the upper arm and knuckle, then tighten the castle nut.
5. Install the knuckle protector with the bolt.

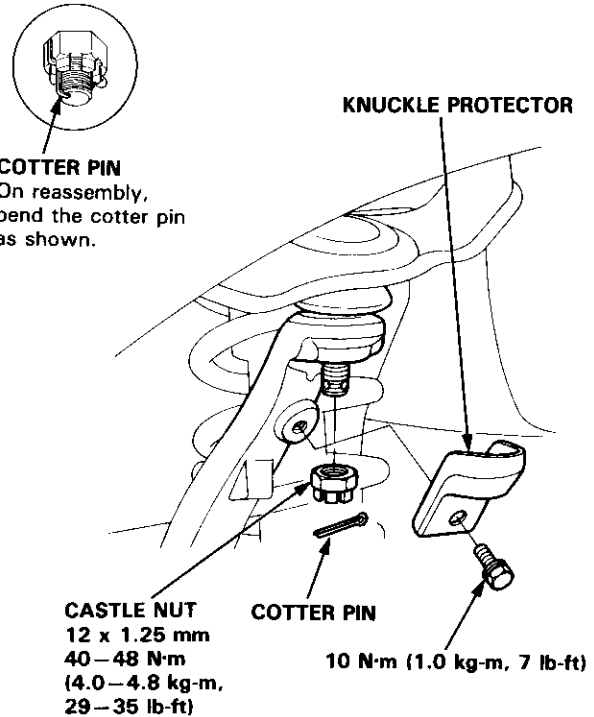

6. Raise the rear suspension with a floor jack until the weight of the car is on the damper.
7. Tighten the damper mounting bolt.

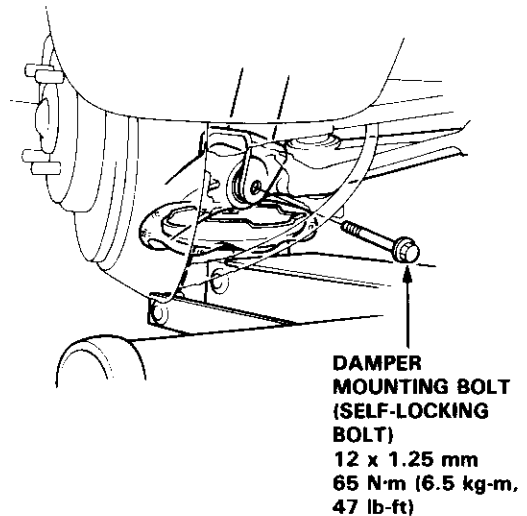

8. Check the rear wheel alignment and adjust if necessary (see page 18-4).

Damper Disposal



⚠ WARNING

- The dampers contain nitrogen gas and oil under pressure. The pressure must be relieved before disposal to prevent explosion and possible injury when scrapping.
- Always wear eye protection to avoid getting metal shavings in your eyes when the gas damper pressure is relieved.

Place the damper on a level surface with its rod extended and drill a hole of 2.0–3.0 mm (0.08–0.12 in) diameter in the body to release the gas.

< Front Damper: >

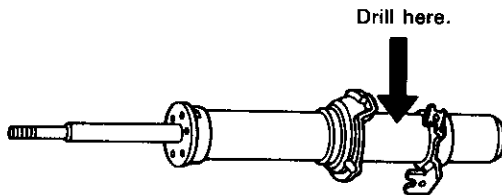

< Rear Damper: >

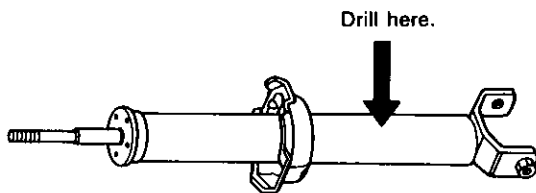

Brakes

Conventional Brakes	19-1
Anti-Lock Brake System (ABS)	19-31



Conventional Brakes

Special Tools	19-2	Rear Disc Brakes	
Illustrated Index	19-3	Torque/Inspection	19-17
Pedal Height		Rear Brake Pads	
Adjustment	19-4	Inspection/Replacement	19-18
Parking Brake		Rear Brake Disc	
Adjustment	19-5	Runout Inspection	19-20
Front Brakes		Thickness and Parallelism	
Torque/Inspection	19-6	Inspection	19-20
Front Brake Pads		Rear Caliper	
Inspection/Replacement	19-7	Disassembly	19-21
Front Caliper		Reassembly	19-24
Disassembly	19-9	Brake Hoses/Pipes	
Reassembly	19-10	Inspection	19-27
Front Brake Disc		Brake Hose Replacement	19-28
Runout Inspection	19-11	Parking Brake	
Thickness and Parallelism		Disassembly and Reassembly	19-29
Inspection	19-11		
Bleeding	19-12		
Master Cylinder and Brake Booster			
Removal/Installation	19-13		
Master Cylinder			
Inspection	19-14		
Brake Booster			
Tests	19-15		
Pushrod Clearance Adjustment	19-15		



Special Tools

Ref. No.	Tool Number	Description	Qty	Page Reference
①	07HAE—SG00100	Brake Spring Compressor	1	19-22, 19-25
②	07JAG—SD40100	Pushrod Adjustment Gauge	1	19-15
③	07914—SA50000	Snap Ring Pliers	1	19-22, 19-25
④	07916—6390001	Locknut Wrench	1	19-21, 19-26

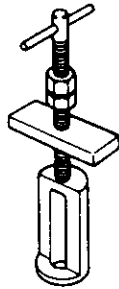

①

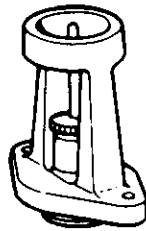

②

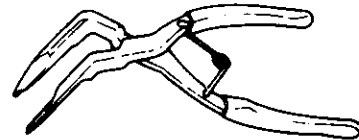

③

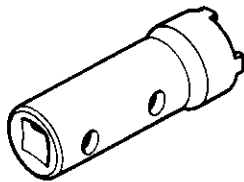

④

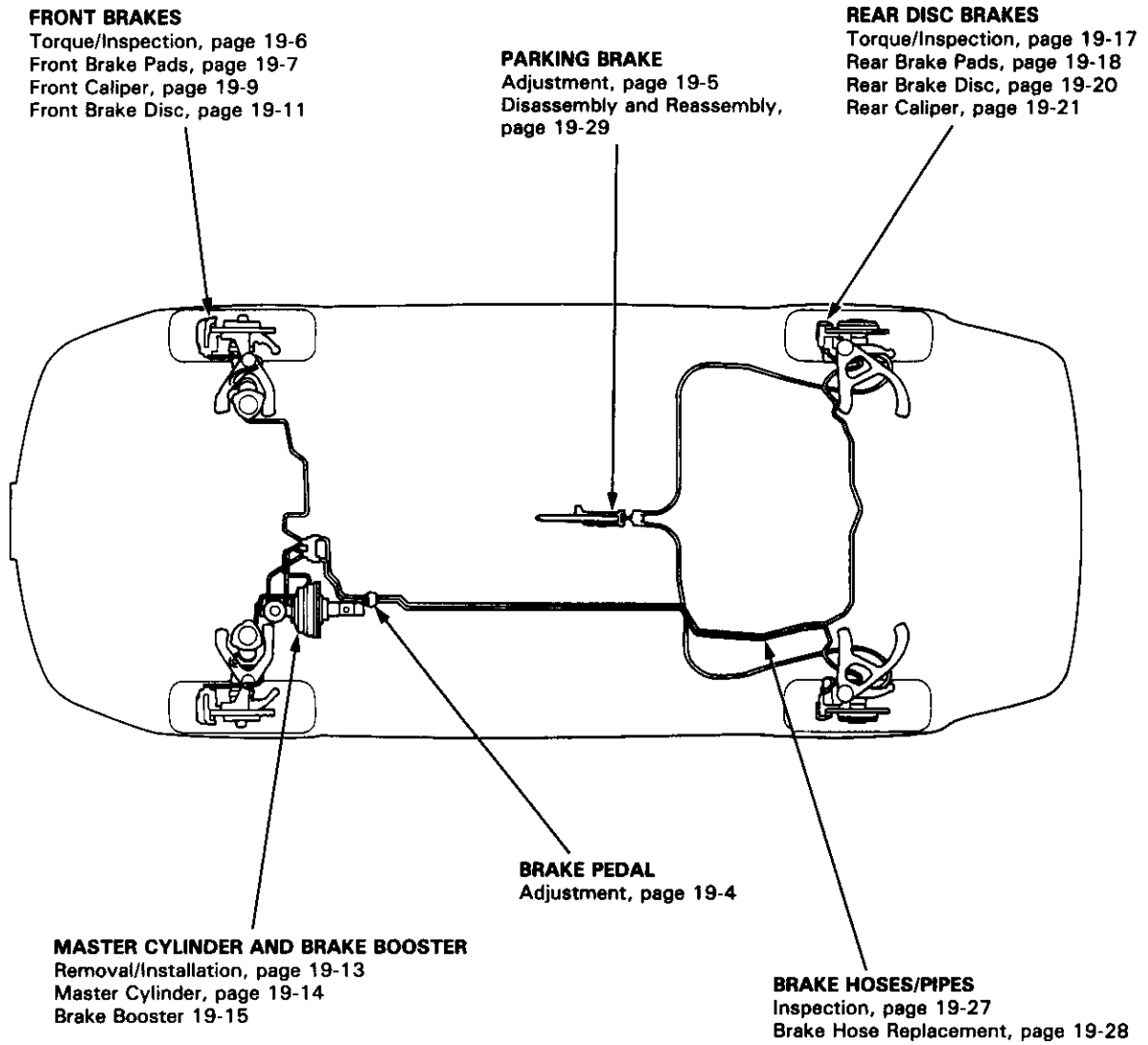

Pedal Height

Adjustment

1. Disconnect the brake switch connector, loosen the brake switch locknut and back off the brake switch until it is no longer touching the brake pedal.
2. Measure the pedal height from the left side center of the pedal surface.

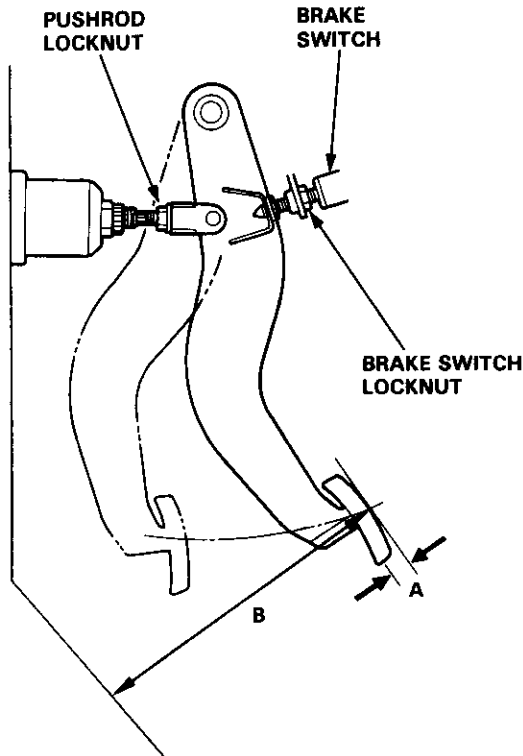

- A: Pedal Free Play**
1–5 mm (1/16–13/64 in)
- B: Standard Pedal Height** (with floor mat removed)
MT: 165 mm (6.5 in) minimum
AT: 186 mm (7.3 in) minimum

3. Loosen the pushrod locknut and screw the pushrod in or out with pliers until the standard pedal height from the floor is reached. After adjustment, tighten the locknut firmly.

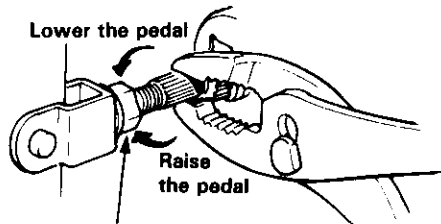

PUSHROD LOCKNUT
15 N·m (1.5 kg-m, 11 lb-ft) for cars without ABS
19 N·m (1.9 kg-m, 14 lb-ft) for cars with ABS

4. Screw in the brake switch until its plunger is fully depressed (threaded end touching the pad on the pedal arm). Then back off the switch 1/4 turn to make 0.3 mm (0.01 in) of clearance between the threaded end and pad. Tighten the locknut firmly. Connect the brake switch connector.

CAUTION: Check that the brake lights go off when the pedal is released.

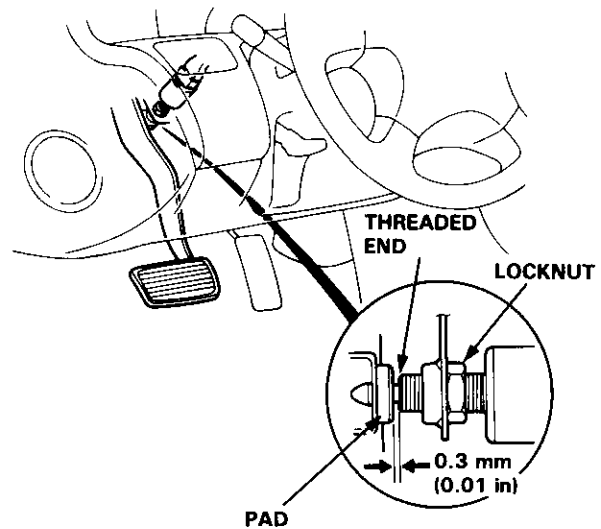

Brake Pedal Free Play Inspection:

Stop the engine and inspect the play by pushing the pedal by hand.

Brake Pedal Free Play: 1–5 mm (1/16–13/64 in)

CAUTION: If the pedal free play is insufficient, it may result in brake drag.



Parking Brake

Adjustment

NOTE: After rear brake caliper servicing, loosen the parking brake adjusting nut, start the engine and depress the brake pedal several times to set the self-adjusting brake before adjusting the parking brake.

⚠ WARNING Block the front wheels before jacking up the rear of the car.

1. Raise the rear wheels off the ground.
2. Make sure the lever of the rear brake caliper contacts the pin of the brake caliper.

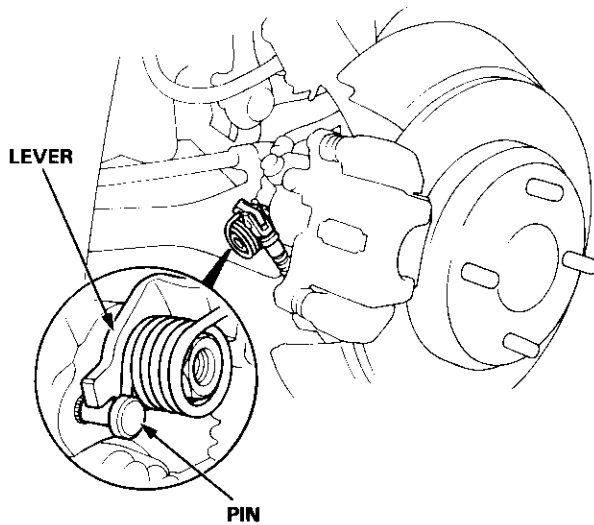

3. Pull the parking brake lever up one notch.
4. Remove the front console and center console (see page 20-51).

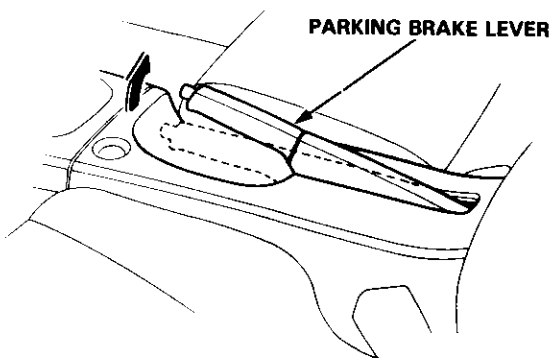

5. Tighten the adjusting nut until the rear wheels drag slightly when turned.

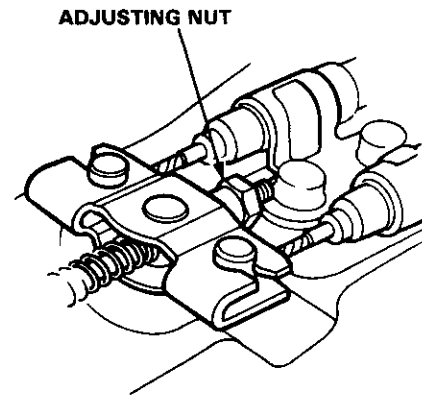

6. Release the parking brake lever and check that the rear wheels do not drag when turned. Readjust if necessary.
7. With the equalizer properly adjusted, the rear brakes should be fully applied when the parking brake lever is pulled up 6 to 10 clicks.

Front Brakes

Torque/Inspection

⚠ WARNING

- Never use an air hose or dry brush to clean brake assemblies.
- Use an OSHA-approved vacuum cleaner, to avoid breathing brake dust.
- Contaminated brake discs or pads reduce stopping ability.

CAUTION:

- Do not spill brake fluid on the car; it may damage the paint; if brake fluid does contact the paint, wash it off immediately with water.
- To prevent spills, cover the hose joints with rags or shop towels.
- Clean all parts in brake fluid and air dry; blow out all passages with compressed air.
- Before reassembling, check that all parts are free of dust and other foreign particles.
- Replace parts with new ones whenever specified to do so.
- Make sure no dirt or other foreign matter is allowed to contaminate the brake fluid.
- Do not mix different brands of brake fluid as they may not be compatible.
- Do not reuse the drained fluid. Use only clean DOT 3 or 4 brake fluid.

NOTE:

- Coat piston, piston seal, and caliper bore with clean brake fluid.
- Replace all rubber parts with new ones whenever disassembled.

 : Brake cylinder grease (P/N: 08733-B020E) or equivalent rubber grease.

 : Silicone grease.

INNER PAD SHIM B
Check for wear or damage.
Apply Molykote® M77 to shim A side of shim.

WEAR INDICATOR
Install inner pad with its wear indicator upward.

OUTER PAD SHIM
Check for wear or damage.
Apply Molykote® M77 to pad side of shim.

PIN B
Check for bending or damage.

12 x 1.25 m
110 N·m (11.0 kg·m, 80 lb-ft)

PIN BOOT
Replace.

INNER PAD SHIM A
Check for wear or damage.
Apply Molykote® M77 to both sides of shim.

BRAKE PADS
Check lining thickness.

BUSHING

10 x 1.0 mm
50 N·m (5.0 kg·m, 36 lb-ft)

PIN A
Check for bending or damage.

CALIPER BRACKET
Check for cracks.

BLEED SCREW
9 N·m
(0.9 kg·m, 6.5 lb-ft)

CALIPER BODY
Check for scoring on cylinder wall.

PISTON SEAL
Replace.

PISTON
Check for scoring on surface.

RETAINER
Check for wear or damage.

PISTON BOOT
Replace.



Front Brake Pads

Inspection/Replacement

⚠ WARNING

- Never use an air hose or dry brush to clean brake assemblies.
- Use an OSHA-approved vacuum cleaner, to avoid breathing brake dust.

1. Loosen the front wheel lug nuts slightly, then raise the car and support on safety stands. Remove the front wheels.
2. Remove the caliper bolt and pivot the caliper up out of the way.

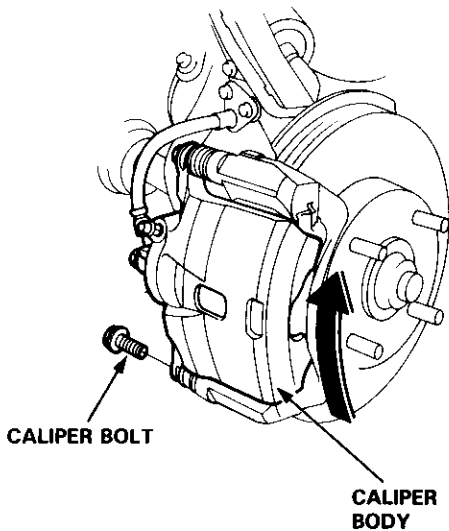

3. If the brake pad thickness is less than service limit at step 5, replace the front pads as a set.

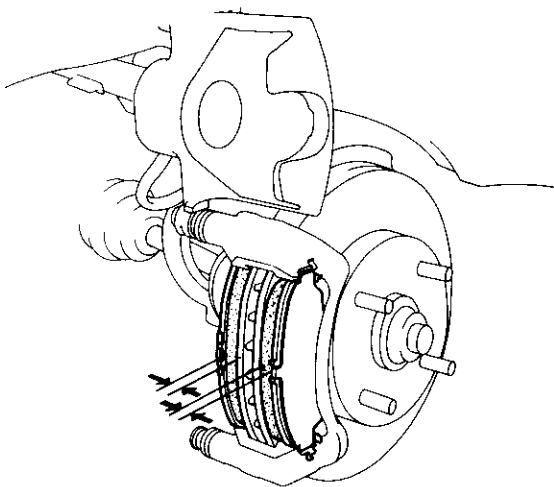

4. Remove the pad shims, pad retainers and pads.
5. Using vernier calipers, measure the thickness of each brake pad lining.

Brake Pad Thickness:

Standard:

F22A1 and H23A1 engine: 12.5 mm (0.49 in)

H22A1 engine: 11.0 mm (0.43 in)

Service Limit:

1.6 mm (0.06 in)

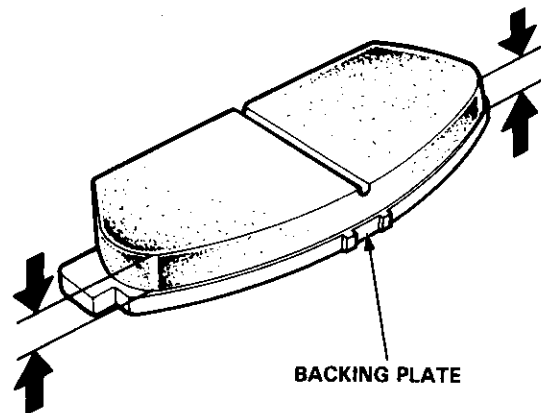

NOTE: Measurement does not include pad backing plate thickness.

6. Clean the caliper thoroughly; remove any rust, and check for grooves or cracks.
7. Install the pad retainers.

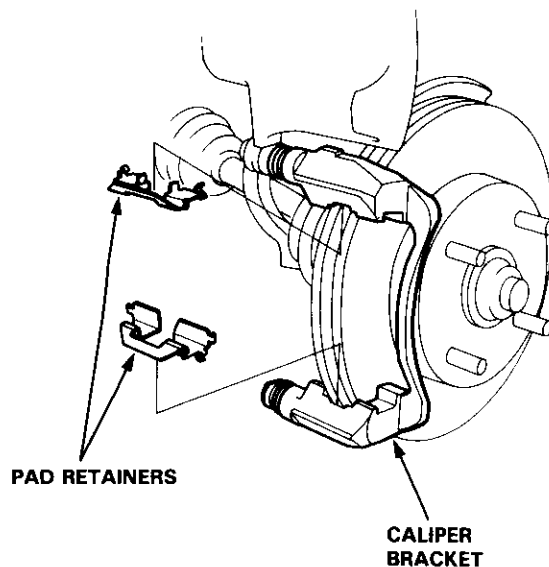

(cont'd)

Front Brake Pads

Inspection/Replacement (cont'd)

8. Apply Molykote® M77 compound to the pad shims and the back of the pads. Wipe off excess.
9. Install the brake pads and pad shims correctly.

▲ WARNING

- When reusing the pads, always reinstall the brake pads in their original positions to prevent loss of braking efficiency.
- Contaminated brake discs or pads reduce stopping ability. Keep grease off the discs and pads.

NOTE: Install the pad with the wear indicator on the inside.

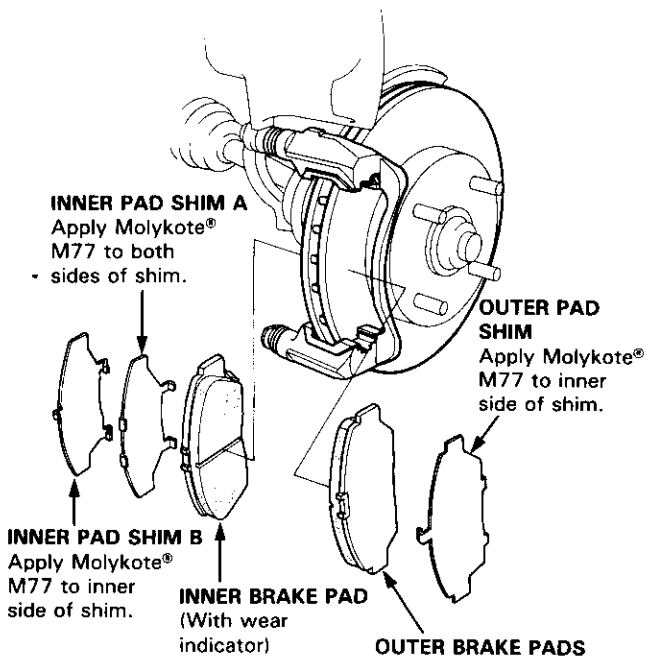

10. Push in the piston so that the caliper will fit over the pads. Keep the boot in position to prevent damaging the boot when pivoting the caliper down.

11. Pivot the caliper down into position, then install the caliper bolt (flange bolt).

NOTE: Make sure the pin is clean before installation, then apply a clean silicone grease to the inside of the boot and the pin.

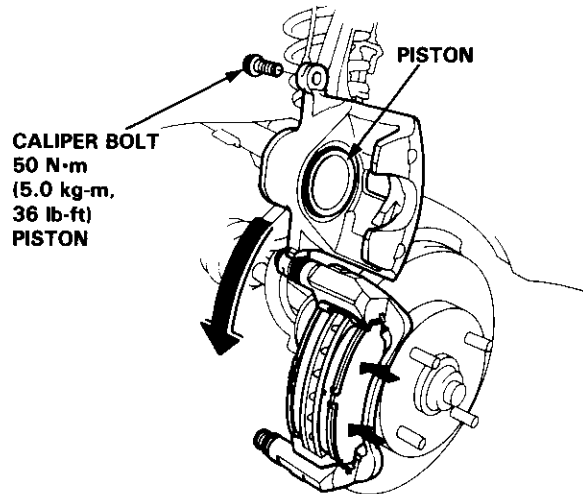

12. Depress the brake pedal several times to make sure the brakes work, then road-test.

NOTE: Engagement of the brake may require a greater pedal stroke immediately after the brake pads have been replaced as a set. Several applications of the brake pedal will restore the normal pedal stroke.



Front Caliper

Disassembly

⚠ WARNING

- Never use an air hose or dry brush to clean brake assemblies.
- Use an OSHA-approved vacuum cleaner to avoid breathing brake dust.

CAUTION:

- Do not spill brake fluid on the car; it may damage the paint; if brake fluid does contact the paint, wash it off immediately with water.
- To prevent spills, cover the hose joints with rags or shop towels.
- Clean all parts in brake fluid and air dry; blow out all passages with compressed air.

1. Remove the banjo bolt and disconnect the brake hose from the caliper.
2. Remove the caliper bolts, then remove the caliper.

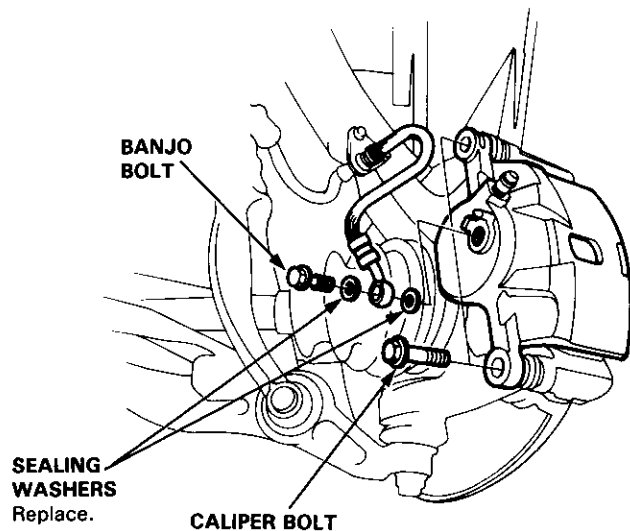

3. If necessary, apply compressed air to the caliper fluid inlet to get the piston out. Place a shop rag or wooden block as shown to cushion the piston when it is expelled. Use low pressure air in short spurts. Remove the piston from the caliper.

⚠ WARNING

- Do not place your fingers in front of the piston.
- Do not use high air pressure; use an OSHA-approved 30 PSI nozzle.

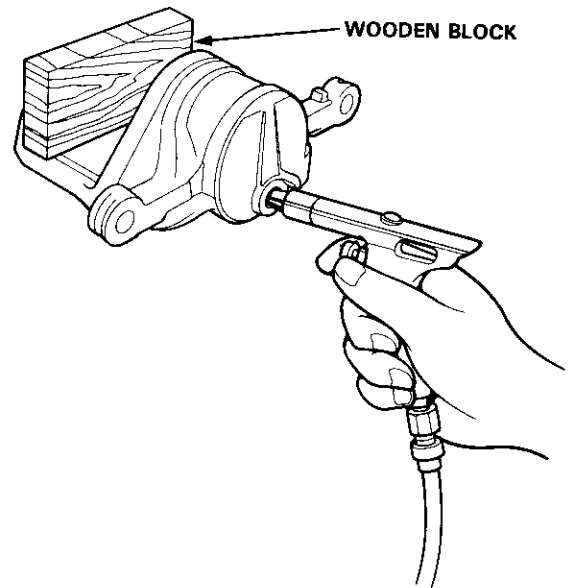

4. Remove the piston boot and piston seal.

CAUTION: Take care not to damage the cylinder bore.

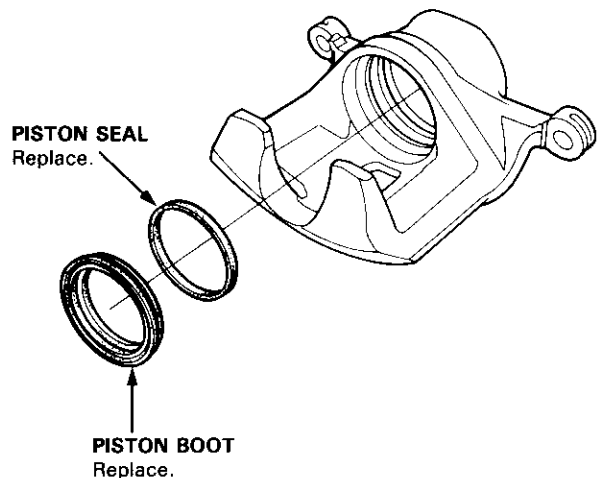

Front Caliper

Reassembly

CAUTION:

- Do not spill brake fluid on the car; it may damage the paint; if brake fluid does contact the paint, wash it off immediately with water.
- Before reassembling, check that all parts are free of dust and other foreign particles.
- Replace parts with new ones whenever specified to do so.
- Make sure no dirt or other foreign matter is allowed to contaminate the brake fluid.
- Do not mix different brands of brake fluid as they may not be compatible.
- Do not reuse the drained fluid. Use only clean DOT 3 or 4 brake fluid.

1. Clean the piston and caliper bore with brake fluid and inspect for wear or damage.
2. Coat a new piston seal with silicone grease and install it in the cylinder groove.
3. Apply brake cylinder grease (P/N: 08733-B020E) or equivalent rubber grease to the sealing lips and inside of a new piston boot, and install the boot in the cylinder groove.

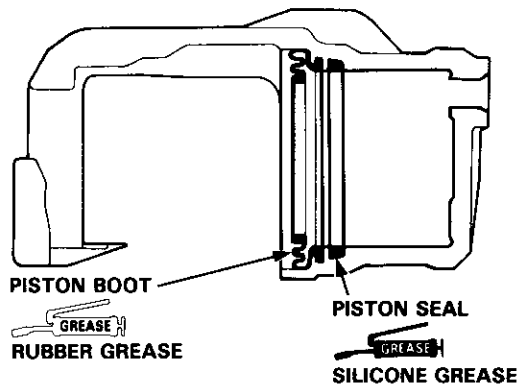

4. Lubricate the caliper cylinder and piston with brake fluid, then install the piston in the cylinder with the dished end facing in.

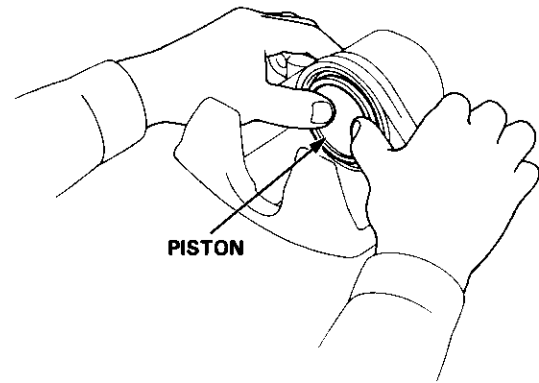

5. Install the brake pad retainers and brake pads in their original positions (see page 19-8).

⚠ WARNING Always reinstall the brake pads in their original positions to prevent loss of braking efficiency.

6. Install the caliper on the caliper bracket and tighten the caliper bolts.
7. Connect the brake hose to the caliper with new sealing washers and tighten the banjo bolt.

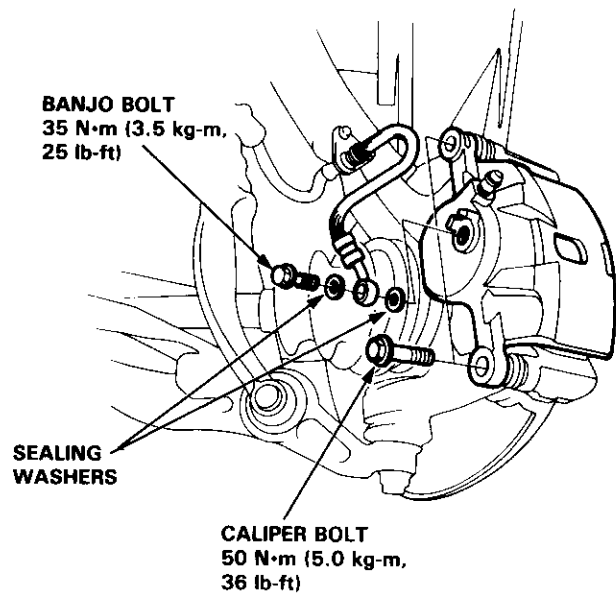

8. Fill the brake reservoir up and bleed the brake system (see page 19-12).



Front Brake Disc

Runout Inspection

1. Loosen the front wheel lug nuts slightly, then raise the car and support on safety stands. Remove the front wheels.
2. Remove the brake pads (see page 19-7).
3. Inspect the disc surface for cracks, and rust. Clean the disc thoroughly and remove all rust.
4. Use lug nuts and suitable plain washers to hold the disc securely against the hub, then mount a dial indicator as shown and measure the runout at 10 mm (0.4 in) from the outer edge of the disc.

Brake Disc Runout:

Service Limit: 0.10 mm (0.004 in)

5. If the disc is beyond the service limit, refinish the rotor with an on-car brake lathe. The Kwik-Lathe produced by Kwik-Way Manufacturing Co. and the "Front Brake Disc Lathe" offered by Snap-on Tools Co. are approved for this operation.

Max. Refinishing Limit: 21.0 mm (0.83 in)

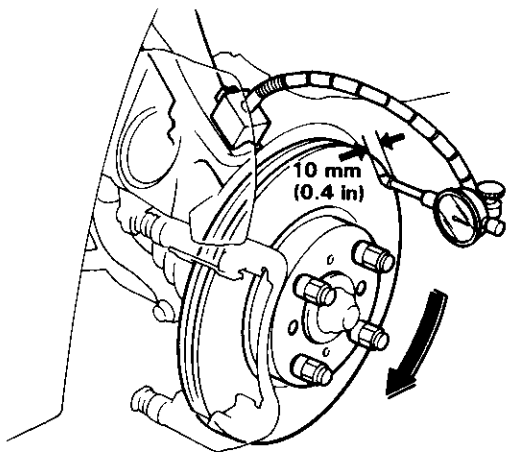

NOTE: A new disc should be refinished if its runout is greater than 0.10 mm (0.004 in).

Thickness and Parallelism Inspection

1. Loosen the front wheel lug nuts slightly, then raise the car and support on safety stands. Remove the front wheels.
2. Remove the brake pads (see page 19-7).
3. Using a micrometer, measure disc thickness at eight points, approximately 45° apart and 10 mm (0.4 in) in from the outer edge of the disc.

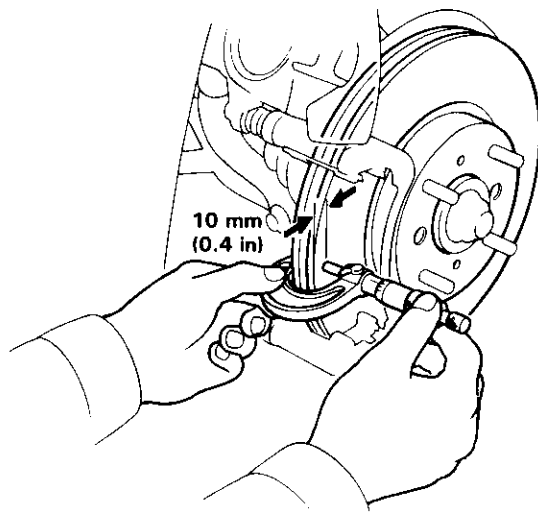

Brake disc thickness:

Standard: 23.0 mm (0.91 in)

Brake Disc Parallelism: 0.015 mm (0.0006 in) max.

NOTE: This is the maximum allowable difference between any thickness measurements.

4. If the disc is beyond the service limit for parallelism, refinish the rotor with an on-car brake lathe. The Kwik-Lathe produced by Kwik-Way Manufacturing Co. and the "Front Brake Disc Lathe" offered by Snap-on Tools Co. are approved for this operation.

Max. Refinishing Limit: 21.0 mm (0.83 in)

Bleeding

CAUTION:

- Use only clean DOT 3 or 4 brake fluid.
- Make sure no dirt or other foreign matter is allowed to contaminate the brake fluid.
- Do not mix different brands of brake fluid as they may not be compatible.
- Do not spill brake fluid on the car; it may damage the paint; if brake fluid does contact the paint, wash it off immediately with water.

NOTE: The reservoir on the master cylinder must be full at the start of bleeding procedure, and checked after bleeding each brake caliper. Add fluid as required. Use only clean DOT 3 or 4 brake fluid.

BLEEDING SEQUENCE:

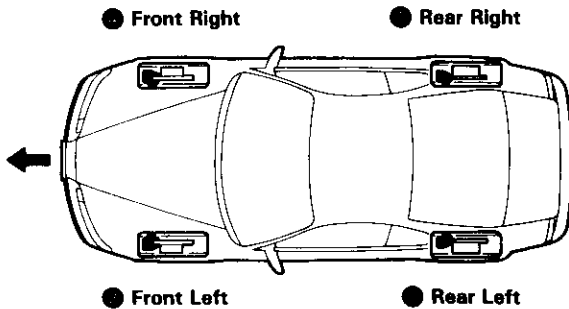

1. Have someone slowly pump the brake pedal several times, then apply steady pressure.
2. Loosen the brake bleed screw to allow air to escape from the system. Then tighten the bleed screw securely.
3. Repeat the procedure for each wheel in the sequence shown above, until air bubbles no longer appear in the fluid.
4. Check brake performance by road testing.

FRONT:

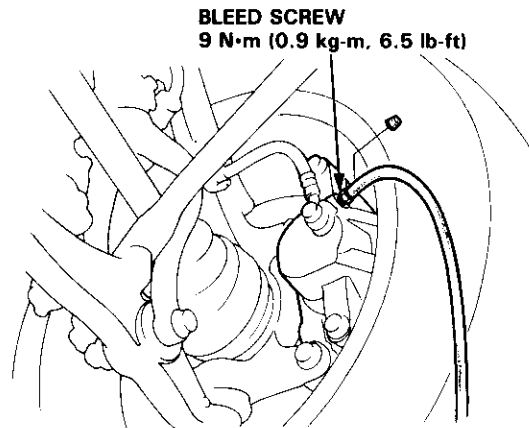

REAR:

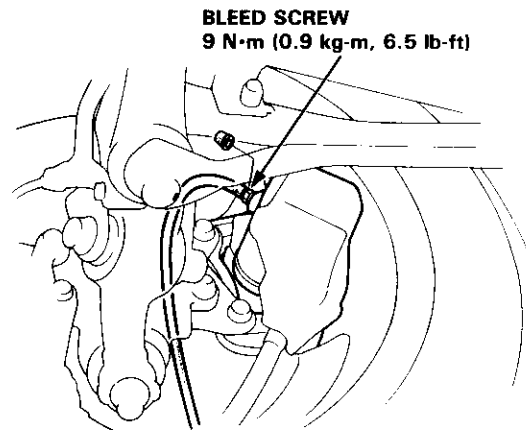

Master Cylinder and Brake Booster



Removal/Installation

CAUTION:

- Be careful not to bend or damage the brake pipes when removing the master cylinder and booster.
- Do not spill brake fluid on the car; it may damage the paint; if brake fluid does contact the paint, wash it off immediately with water.
- To prevent spills, cover the hose joints with rags or shop towels.
- Before reassembling, check that all parts are free of dust and other foreign particles.
- Make sure no dirt or other foreign matter is allowed to contaminate the brake fluid.
- Do not mix different brands of brake fluid as they may not be compatible.
- Do not reuse the drained fluid. Use only clean DOT 3 or 4 brake fluid.
- When connecting the brake pipes, make sure that there is no interference between the brake pipes and other parts.
- Do not disassemble the master cylinder or booster. Replace them as complete assemblies.

1. Drain the brake fluid from the master cylinder.
2. Disconnect the brake fluid level switch connectors.
3. Disconnect the brake pipes from the master cylinder.
4. Remove the master cylinder mounting nuts and the master cylinder.
5. Disconnect the vacuum hose from the booster and remove the vacuum hose bracket.
6. Remove the throttle/cruise control cable bracket, then remove the throttle cable grommet from the engine compartment bulkhead.
7. Remove the intake air temperature sensor from the intake manifold.
8. Loosen the pushrod locknut, and remove the cotter pin and joint pin.
9. Remove the booster mounting nuts and clevis.
10. Remove the brake booster (see next page).

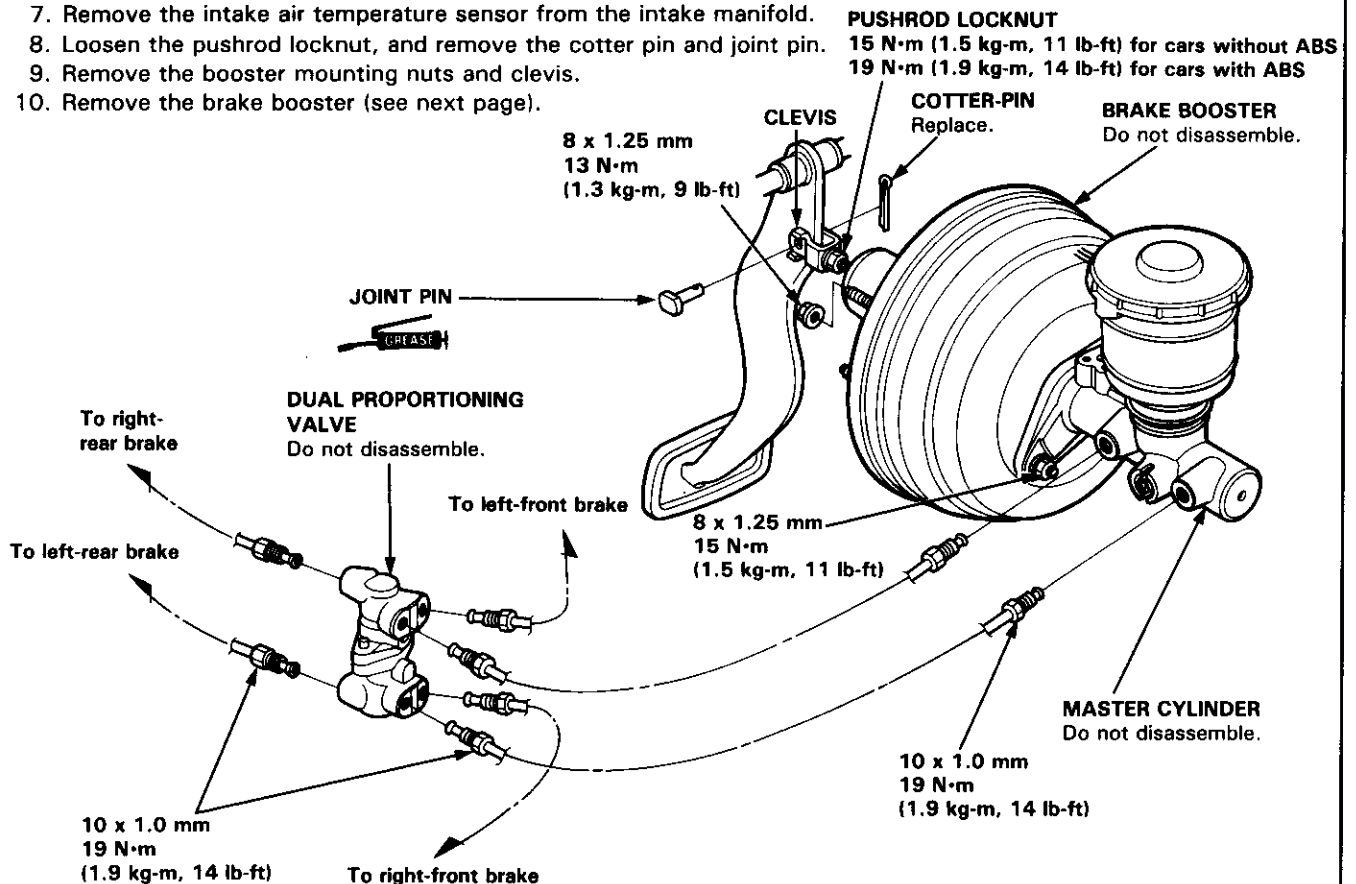

11. Install the brake booster and master cylinder in the reverse order of removal.

NOTE: Before installing the master cylinder, check and adjust the pushrod clearance (see page 19-15).

12. After installation, check and adjust the brake pedal height (see page 19-4).
13. Fill and bleed the brake system (see page 19-12).

(cont'd)

Master Cylinder and Brake Booster

Removal/Installation (cont'd)

Booster Replacement

1. Pull the brake booster forward, then turn it to the right until the operating rod is clear of the bulkhead as shown below.
2. Move the operating rod beyond the left damper base by turning the brake booster.

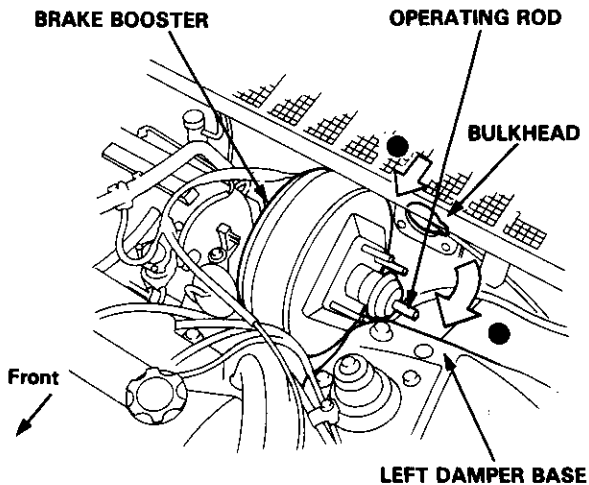

3. Continue to turn the brake booster until the operating rod points forward.
4. Remove the brake booster from the engine compartment with the front cylinder shell side of the brake booster upward.

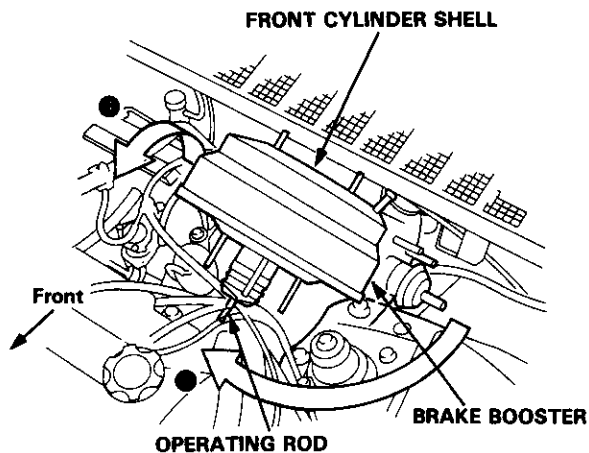

Master Cylinder

Inspection

CAUTION:

- Do not spill brake fluid on the car; it may damage the paint; if brake fluid does contact the paint, wash it off immediately with water.
- Before reassembling, check that all parts are free of dust and other foreign particles.
- Do not try to disassemble the master cylinder assembly. Replace the master cylinder assembly with a new part if necessary.
- Make sure no dirt or other foreign matter is allowed to contaminate the brake fluid.

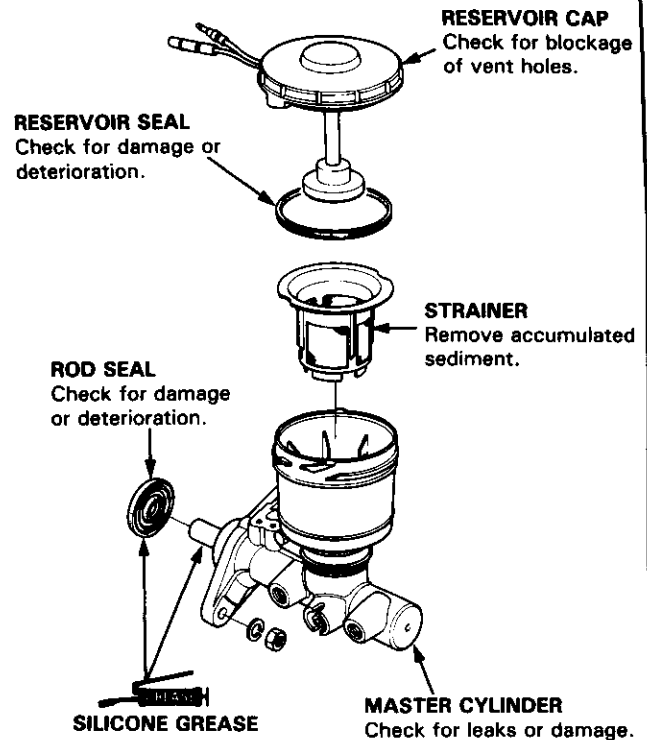

Brake Booster



Tests

Functional Test

1. With the engine stopped, depress the brake pedal several times, then depress the pedal hard and hold that pressure for 15 seconds. If the pedal sinks, the master cylinder, brake line or a brake caliper is faulty.
2. Start the engine with the pedal depressed. If the pedal sinks slightly, the vacuum booster is working. If the pedal height does not vary, the booster or check valve is faulty.

Leak Test

1. Depress the brake pedal with the engine running, then stop the engine. If the pedal height does not vary while depressed for 30 seconds, the vacuum booster is OK. If the pedal rises, the booster is faulty.

CAUTION: Do not try to disassemble the booster. Replace the booster assembly with a new one.

2. With the engine stopped, depress the brake pedal several times using normal pressure. When the pedal is first depressed, it should be low. On consecutive applications, pedal height should gradually rise. If the pedal position does not vary, check the booster check valve.

Check Valve Test

1. Disconnect the brake booster vacuum hose at the booster.
2. Start the engine and let it idle. There should be vacuum available. If no vacuum is available, the check valve is not working correctly. Replace the check valve and retest.

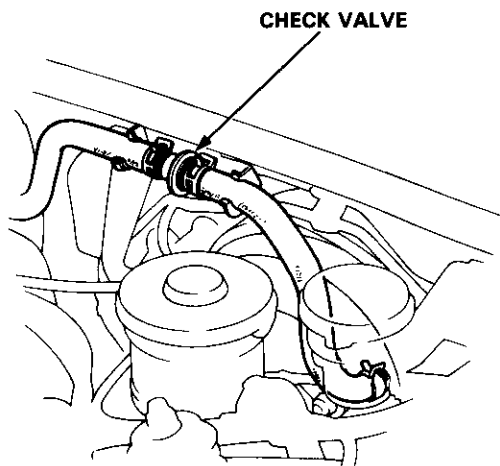

Pushrod Clearance Adjustment

NOTE: Master cylinder pushrod-to-piston clearance must be checked and adjustments made, if necessary, before installing master cylinder.

1. Set the special tool on the master cylinder body; push in the center shaft until the top of it contacts with the end of the secondary piston by turning the adjusting nut.

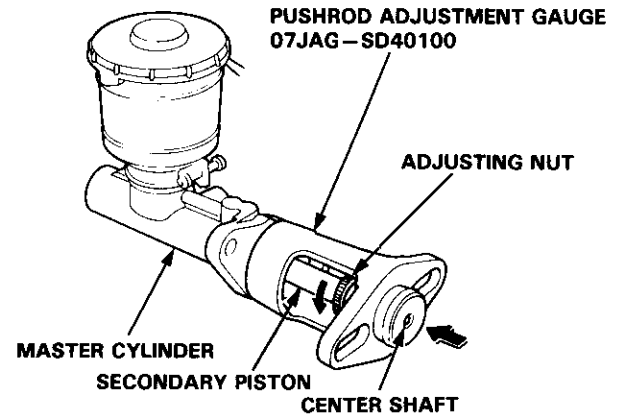

2. Without disturbing the center shaft's position, install the special tool upside down on the booster.
3. Install the master cylinder nuts and tighten to the specified torque.
4. Connect the booster in-line with a vacuum gauge 0-760 mm Hg (0-30 in Hg) to the booster's engine vacuum supply, and maintain a engine speed that will deliver 500 mm Hg (20 in Hg) vacuum.
5. With a feeler gauge, measure the clearance between the gauge body and the adjusting nut as shown.

Clearance:

Cars without ABS: 0-0.4 mm (0-0.02 in)

Cars with ABS: 0-0.2 mm (0-0.01 in)

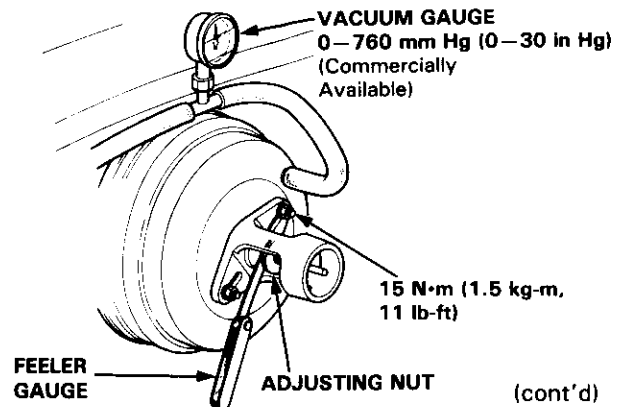

(cont'd)

Brake Booster

Pushrod Clearance Adjustment (cont'd)

NOTE: If the clearance between the gauge body and adjusting nut is 0.4 mm (0.02 in) [cars with ABS: 0.2 mm (0.01 in)], the pushrod-to-piston clearance is 0 mm. However, the clearance between the gauge body and adjusting nut is 0 mm, the pushrod-to-piston clearance is 0.4 mm (0.02 in) [cars with ABS: 0.2 mm (0.01 in)] or MORE. Therefore, it must be adjusted and rechecked.

6. If the clearance is incorrect:
- Cars without ABS: loosen the star locknut and adjust the clearance by turning the adjuster in or out while holding the pushrod. Tighten the star locknut to the specified torque and remove the special tool.

NOTE:

- Adjust the clearance while the specified vacuum is applied to the booster.
- Hold the clevis while adjusting.

0–0.4 mm (0–0.02 in)

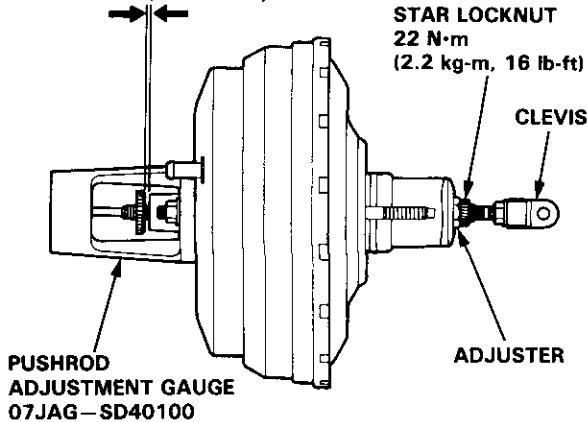

- Cars with ABS: remove the special tool and adjust the clearance by turning the adjuster in or out while holding the output rod.

0–0.2 mm (0–0.01 in)

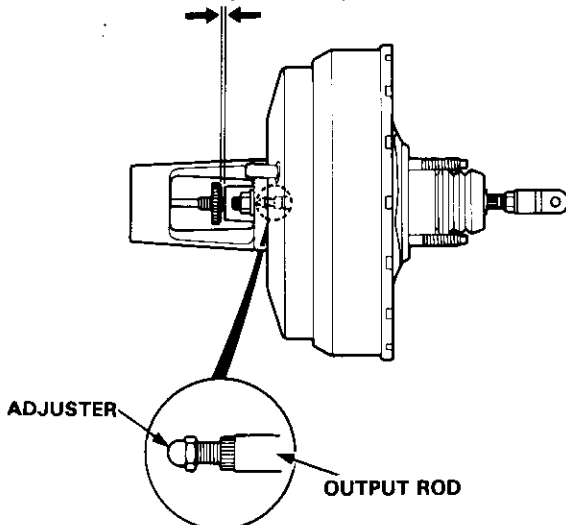

7. Adjust the pushrod length as shown if the booster is removed.

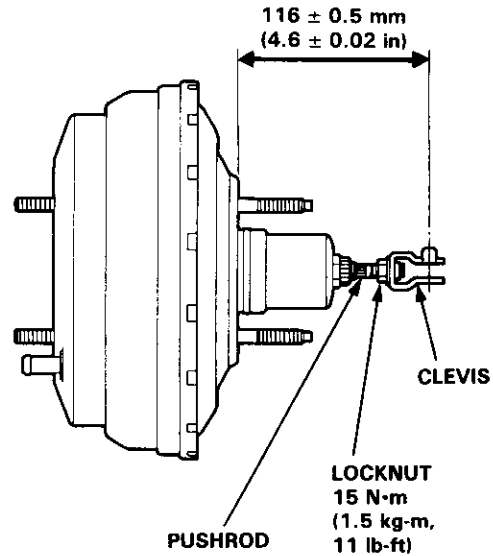

8. Install the master cylinder (see page 19-13).
9. After installation, perform the following inspections and adjust if necessary.
- Brake pedal height (see page 19-4)
 - Brake pedal free play (see page 19-4)

Rear Disc Brakes

Torque/Inspection



⚠ WARNING

- Never use an air hose or dry brush to clean brake assemblies.
- Use an OSHA-approved vacuum cleaner, to avoid breathing brake dust.
- Contaminated brake discs or pads reduce stopping ability.

CAUTION:

- Do not spill brake fluid on the car; it may damage the paint; if brake fluid does contact the paint, wash it off immediately with water.
- To prevent spills, cover the hose joints with rags or shop towels.
- Clean all parts in brake fluid and air dry; blow out all passage with compressed air.
- Before reassembling, check that all parts are free of dust and other foreign particles.
- Replace parts with new ones whenever specified to do so.
- Make sure no dirt or other foreign matter is allowed to contaminate the brake fluid.
- Do not mix different brands of brake fluid as they may not be compatible.
- Do not reuse the drained fluid. Use only clean DOT 3 or 4 brake fluid.

NOTE:

- Coat piston, piston seal, and caliper bore with clean brake fluid.
- Replace all rubber parts with new ones whenever disassembled.

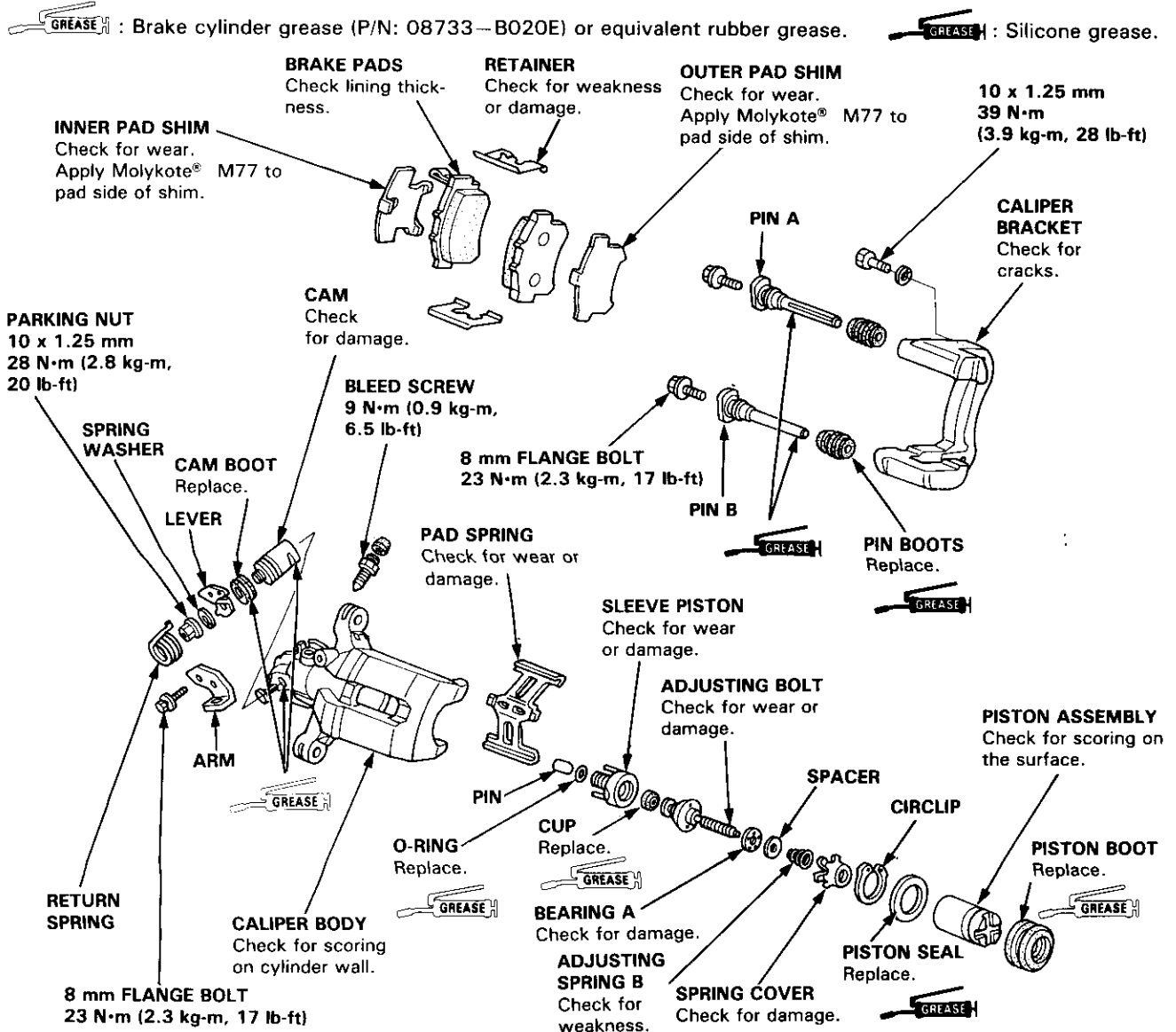

Rear Brake Pads

Inspection/Replacement

⚠ WARNING

- Never use an air hose or dry brush to clean brake assemblies.
- Use an OSHA-approved vacuum cleaner, to avoid breathing brake dust.

1. Block the front wheels, loosen the rear wheel lug nuts slightly, support the rear of car on safety stands, then remove the rear wheels. Release the parking brake.
2. Remove the caliper shield.

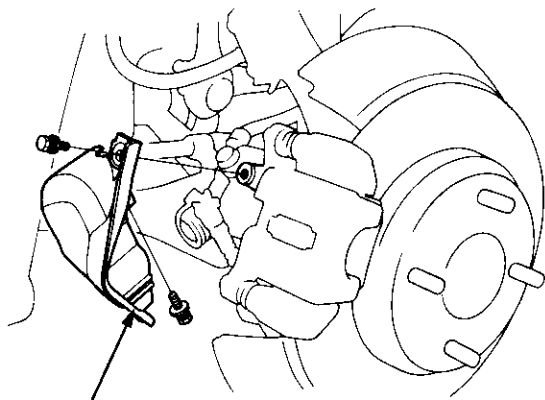

CALIPER SHIELD

3. Remove the two caliper mounting bolts and the caliper from the bracket.

CAUTION:

- Thoroughly clean the outside of the caliper to prevent dust and dirt from entering inside.
- Support the caliper with a piece of wire so that it does not hang from the brake hose.

CALIPER MOUNTING BOLTS

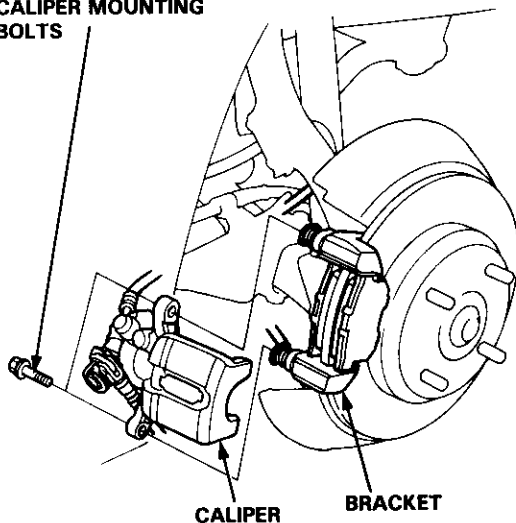

CALIPER

BRACKET

If lining thickness is less than service limit at step 5, replace the rear pads as a set.

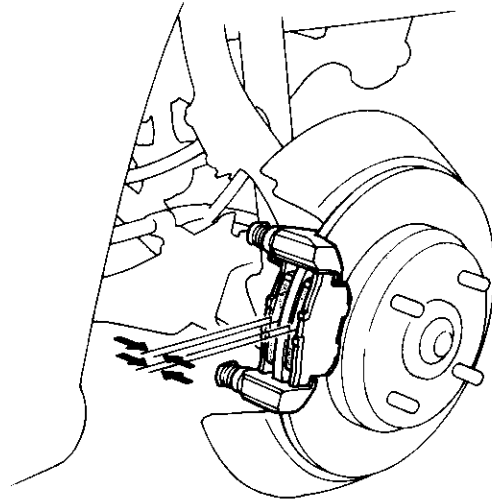

4. Remove the pad shims, pads and pad retainers.
5. Using vernier calipers, measure the thickness of each brake pad lining.

Brake Pad Thickness:

Standard: 9.0 mm (0.35 in)

Service Limit: 1.6 mm (0.06 in)

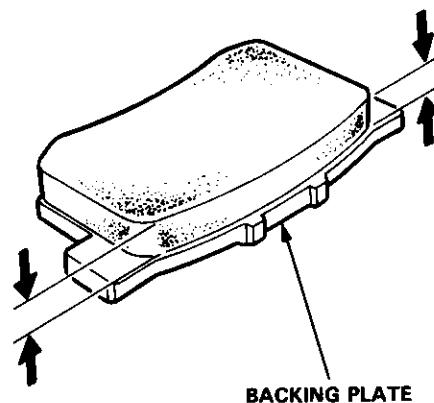

BACKING PLATE

NOTE: Measurement does not include pad backing plate thickness.



6. Clean the caliper thoroughly; remove any rust, and check for grooves or cracks.
7. Make sure that the pad retainers are installed in the correct positions.

PAD RETAINERS

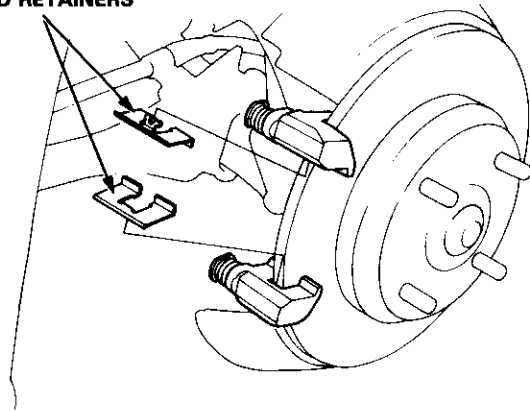

8. Install the brake pads and pad shims on caliper bracket.

⚠ WARNING

- When reusing the pads, always reinstall the brake pads in their original positions to prevent loss of braking efficiency.
- Contaminated brake discs or pads reduce stopping ability. Keep grease off the discs and pads.

NOTE:

- Apply Molykote® M77 to the pad side of the shims. Wipe excess grease off the shims.
- Install the inner pad with its wear indicator facing upward.

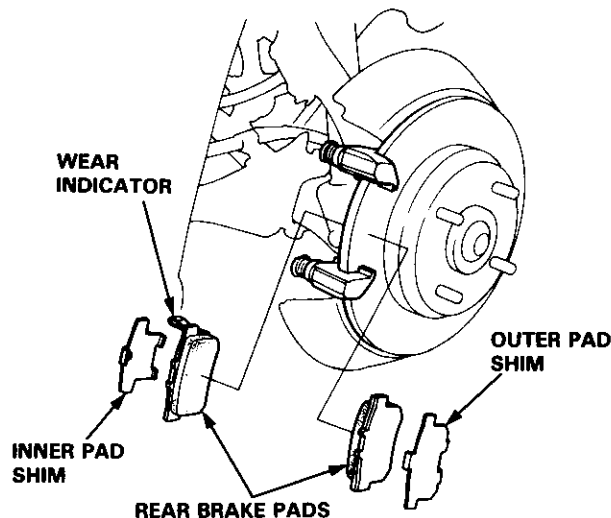

9. Rotate the caliper piston clockwise into place in the cylinder, then align the cutout in the piston with the tab on the inner pad by turning the piston back.

CAUTION: Lubricate the boot with silicone grease to avoid twisting the piston boot. If piston boot is twisted, back it out so it sits properly.

10. Install the caliper on the caliper bracket and tighten the caliper mounting bolts.

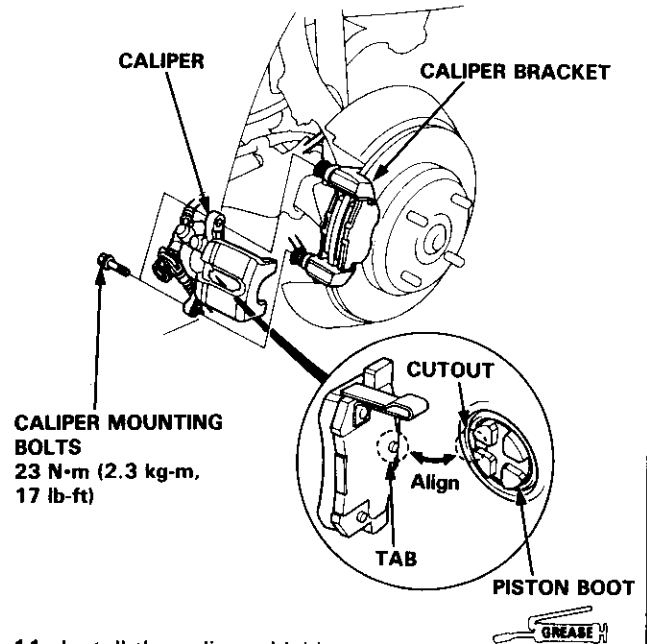

11. Install the caliper shield.

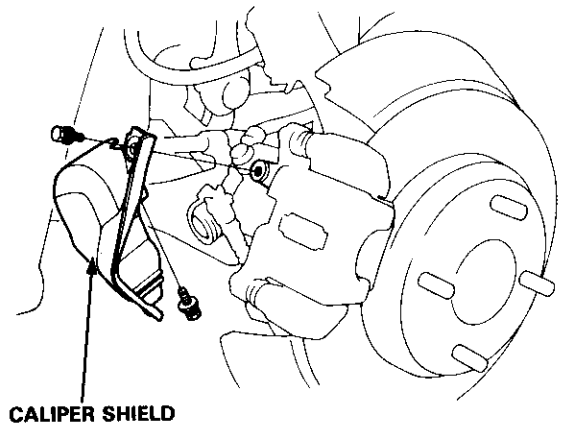

12. Depress the brake pedal several times to make sure the brakes work, then road-test.

NOTE: Engagement of the brake may require a greater pedal stroke immediately after the brake pads have been replaced as a set. Several applications of the brake pedal will restore the normal pedal stroke.

Rear Brake Disc

Runout Inspection

1. Loosen the rear wheel lug nuts slightly, then raise the car and support on safety stands. Remove the rear wheels.
2. Remove the brake pads (see page 19-18).
3. Inspect the disc surface for grooves, cracks, and rust. Clean the disc thoroughly and remove all rust.
4. Use lug nuts and suitable plain washers to hold the disc securely against the hub, then mount a dial indicator as shown and measure the runout at 10 mm (0.4 in) from the outer edge of the disc.

Brake Disc Runout:

Service Limit: 0.10 mm (0.004 in)

5. If the disc is beyond the service limit, refinish the rotor.

Max. Refinishing Limit: 8.0 mm (0.32 in)

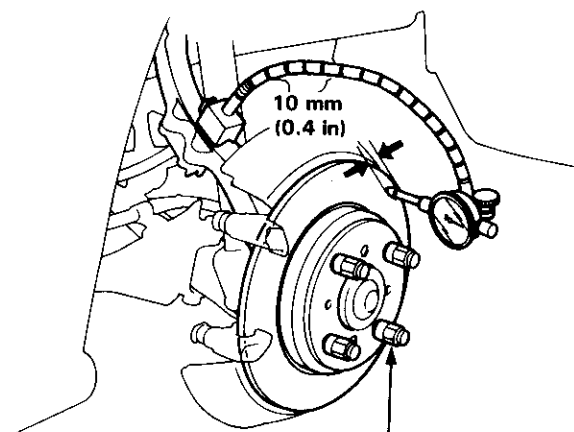

WHEEL NUT
110 N·m
(11 kg-m, 80 lb-ft)

NOTE: A new disc should be refinished if its runout is greater than 0.10 mm (0.004 in).

Thickness and Parallelism Inspection

1. Loosen the rear wheel lug nuts slightly, then raise the car and support on safety stands. Remove the rear wheels.
2. Remove the brake pads (see page 19-18).
3. Using a micrometer, measure disc thickness at eight points, approximately 45° apart and 10 mm (0.4 in) in from the outer edge of the disc.

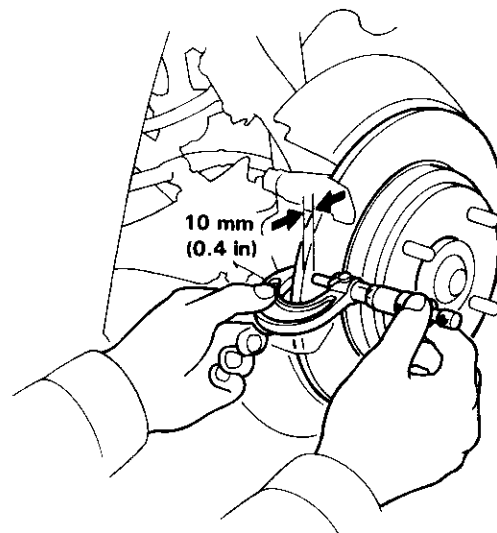

Brake Disc Thickness:

Standard: 10.0 mm (0.39 in)

Brake Disc Parallelism: 0.015 mm (0.0006 in) max.

NOTE: This is the maximum allowable difference between any thickness measurements.

4. If the disc is beyond the service limit for parallelism, refinish the rotor.

Max. Refinishing Limit: 8.0 mm (0.32 in)



Rear Caliper

Disassembly

⚠ WARNING

- Never use an air hose or dry brush to clean brake assemblies.
- Use an OSHA-approved vacuum cleaner to avoid breathing brake dust.

CAUTION:

- Do not spill brake fluid on the car; it may damage the paint; if brake fluid does contact the paint, wash it off immediately with water.
- To prevent spills, cover the hose joints with rags or shop towels.
- Clean all parts in brake fluid and air dry; blow out all passages with compressed air.

1. Remove the caliper shield (see page 19-18).
2. Remove the lock pin and clevis pin. Remove the cable clip and disconnect the parking brake cable from the arm.

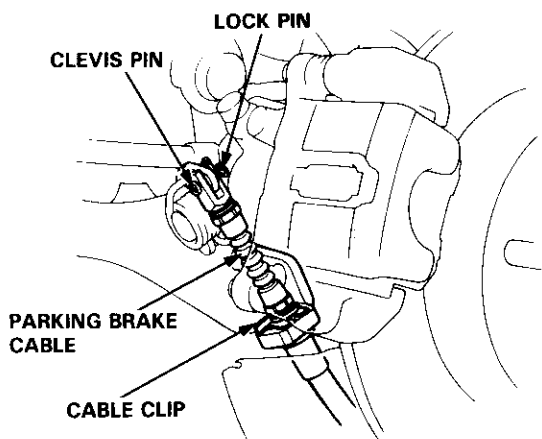

3. Remove the banjo bolt and two sealing washers.
4. Remove the two caliper mounting bolts and caliper body from the bracket.

CALIPER MOUNTING BOLT

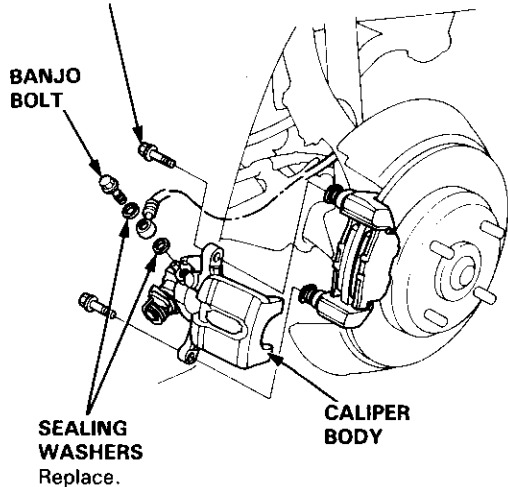

5. Remove the pad spring from the caliper body.
6. Remove the piston by rotating the piston counterclockwise with the special tool and remove the piston boot.

CAUTION: Avoid damaging the piston.

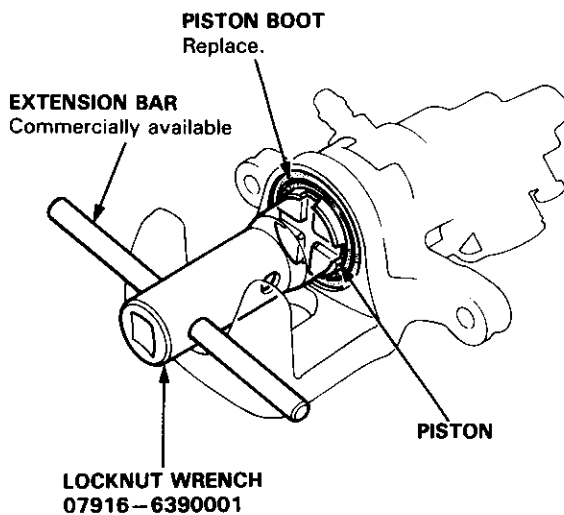

7. Remove the piston seal.

CAUTION: Take care not to damage the cylinder bore.

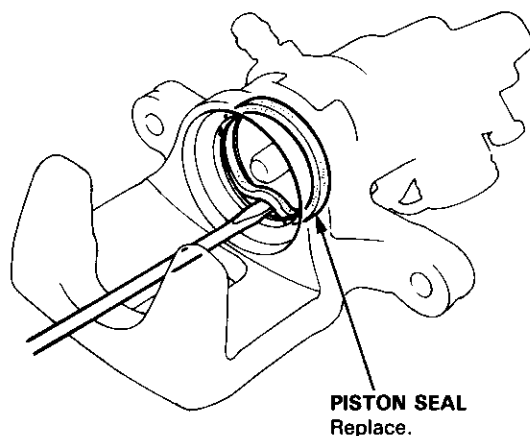

(cont'd)

Rear Caliper

Disassembly (cont'd)

8. Install the special tool between the caliper body and spring cover.

CAUTION: Be careful not to damage the inside of the caliper cylinder during caliper disassembly.

9. Position the locknuts as shown, then turn the shaft until the plate just contacts the caliper body.

NOTE: Do not compress the spring under the spring cover.

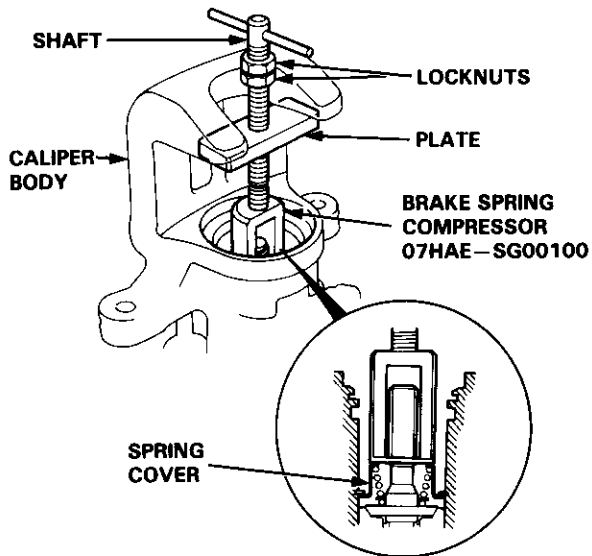

10. Turn the shaft clockwise 1/4–1/2 turn to compress the adjusting spring B in the caliper body.

CAUTION: To prevent damage to the inner components, do not turn the shaft more than 1/2 turn.

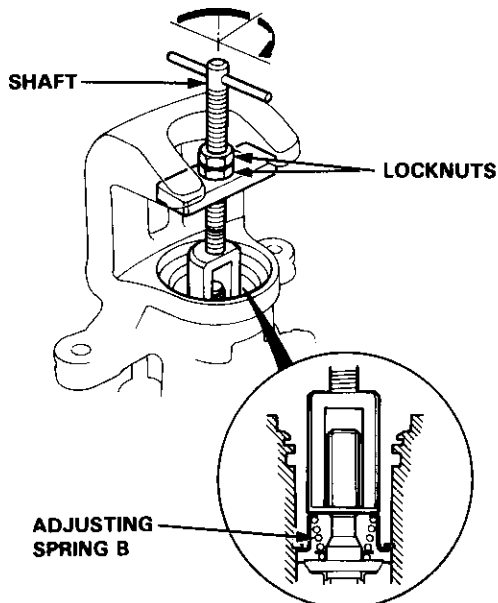

11. Lower the locknuts fully and tighten the locknuts securely.

NOTE: Keep the locknuts in this position until you reinstall the circlip.

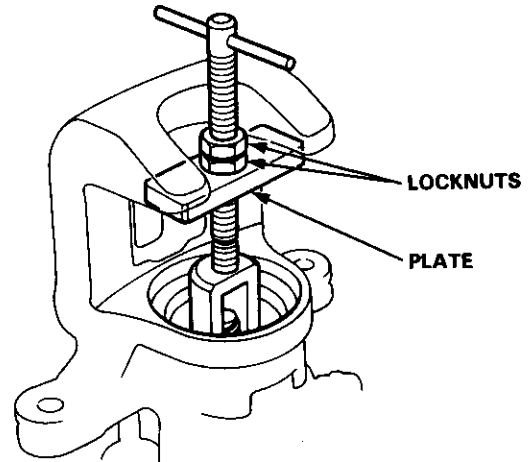

12. Remove the circlip with snap ring pliers.

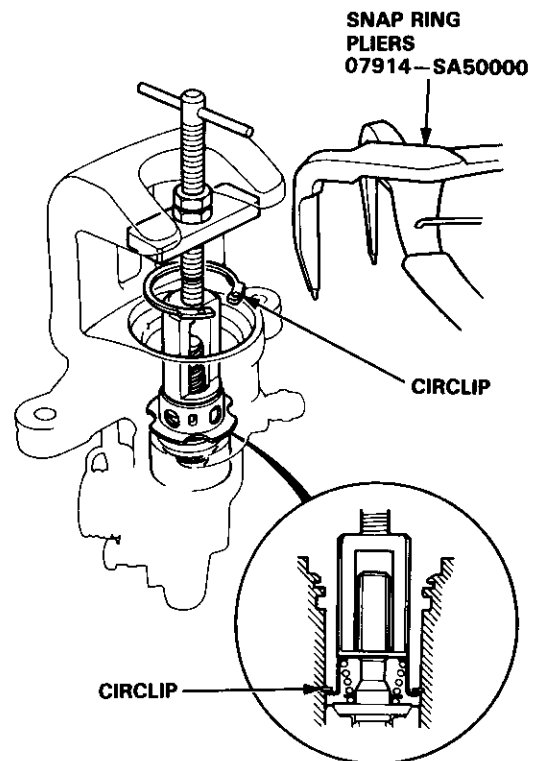



13. Hold the plate with your fingers and turn the shaft counterclockwise. Remove the special tool from the caliper.

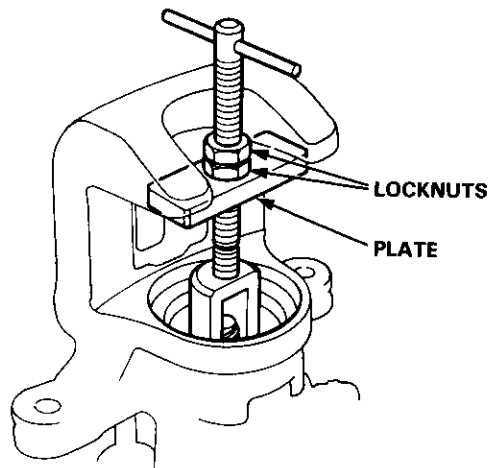

14. Remove the adjusting bolt.
15. Remove the spring cover, adjusting spring B, spacer, bearing A and cup from the adjusting bolt.

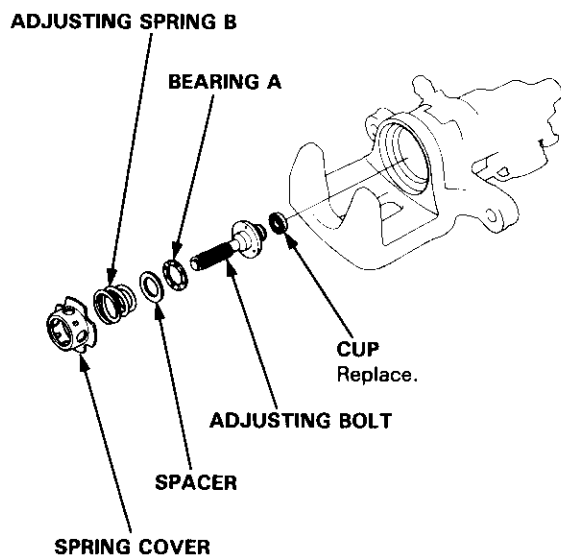

16. Remove the sleeve piston, and remove the pin from the cam.

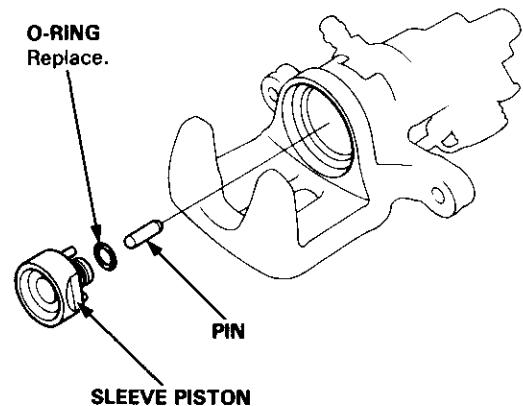

17. Remove the return spring.
18. Remove the parking lever and cam as an assembly from the caliper body.

CAUTION: Do not loosen the parking nut with the cam installed in the caliper body. If the lever and shaft must be separated, hold the lever in a vise and loosen the parking nut.

19. Remove the cam boot.

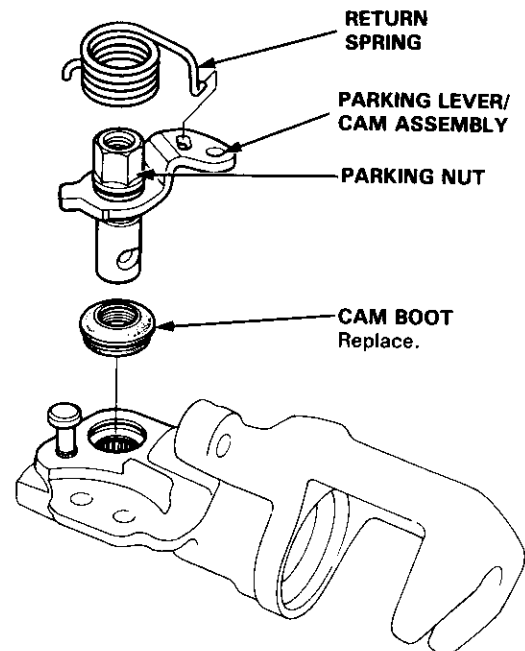

Rear Caliper

Reassembly

CAUTION:

- Do not spill brake fluid on the car; it may damage the paint; if brake fluid does contact the paint, wash it off immediately with water.
- Before reassembling, check that all parts are free of dust and other foreign particles.
- Replace parts with new ones whenever specified to do so.
- Make sure no dirt or other foreign matter is allowed to contaminate the brake fluid.
- Do not mix different brands of brake fluid as they may not be compatible.
- Do not reuse the drained fluid. Use only clean DOT 3 or 4 brake fluid.

1. Pack all cavities of the needle bearing with commercially available assembly lube.
2. Coat the new cam boot with commercially available assembly lube and install it in the caliper body.
3. Apply commercially available assembly lube to the pin contacting area of the cam and install the cam and lever assembly into the caliper body.
4. Install the return spring.

CAUTION:

- When the cam and lever were separated, be sure to assemble them before installing the cam in the caliper body. Install the lever and spring washer, apply locking agent to the threads, and tighten the parking nut while holding the lever with a vise.
- Avoid damaging the cam boot since it must be installed before the cam.
- When installing the cam, do not allow the cam boot lips to turn outside in.

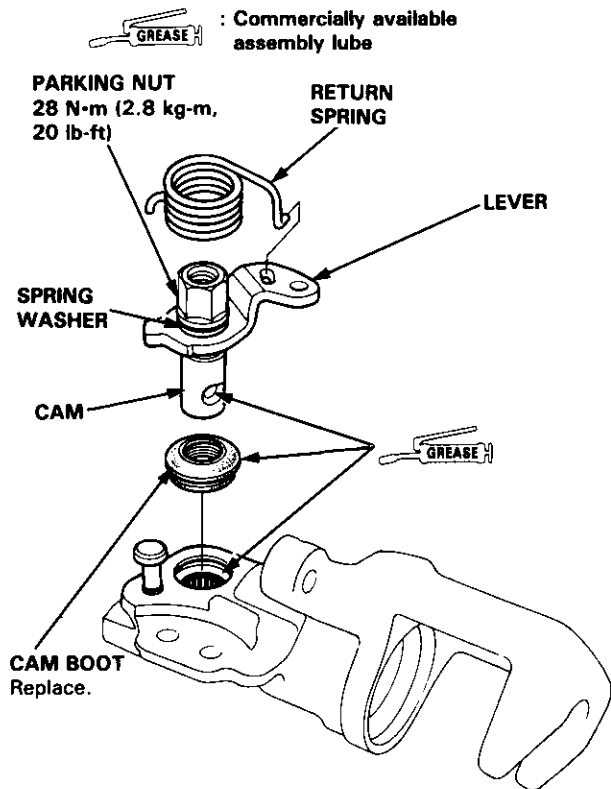

5. Install the pin in the cam.
6. Install a new O-ring on the sleeve piston.
7. Install the sleeve piston so the hole in the bottom of the piston is aligned with the pin in the cam, and two pins on the piston are aligned with the holes in the caliper.

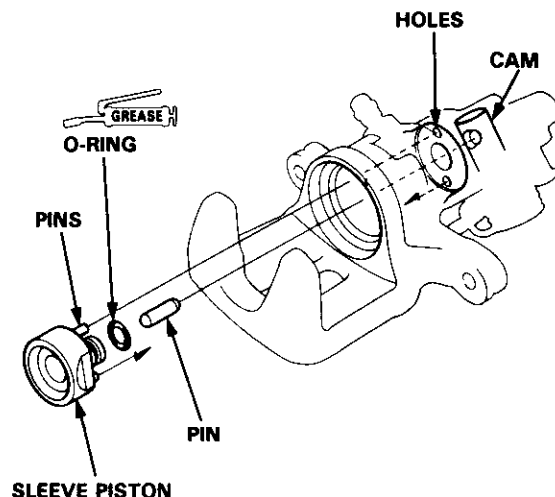



8. Coat a new cup with brake cylinder grease (P/N: 08733-B020E) or equivalent rubber grease, and install it with its groove facing the bearing A side of the adjusting bolt.

9. Fit the bearing A, spacer, adjusting spring B and spring cover on the adjusting bolt, and install them in the caliper cylinder.

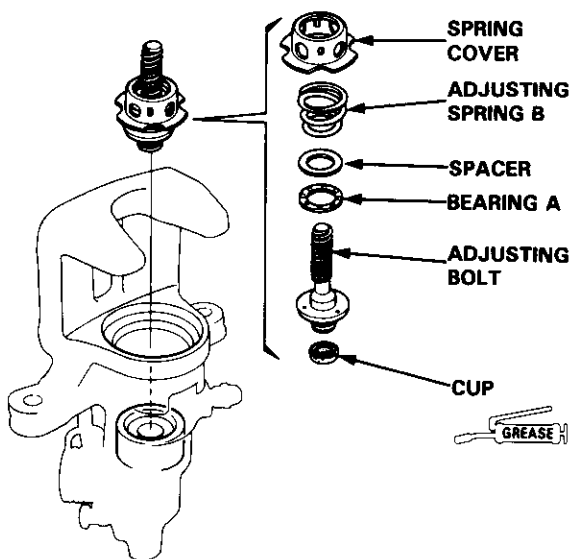

10. Install the special tool on the spring cover and turn the shaft until the locknut contacts the plate.

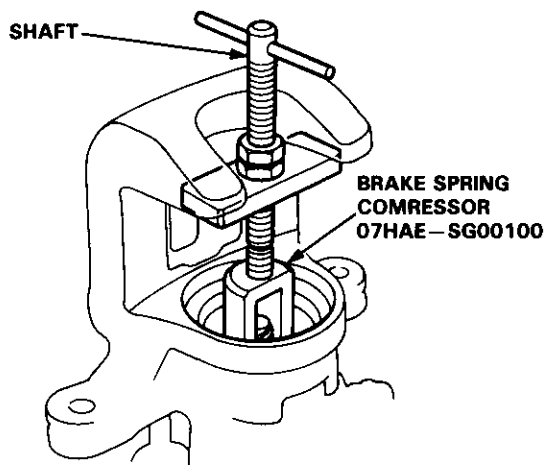

11. Check that the flared end of the spring cover is below the circlip groove.

12. Install the circlip in the groove, then remove the special tool.

NOTE: Check that the circlip is seated in the groove properly.

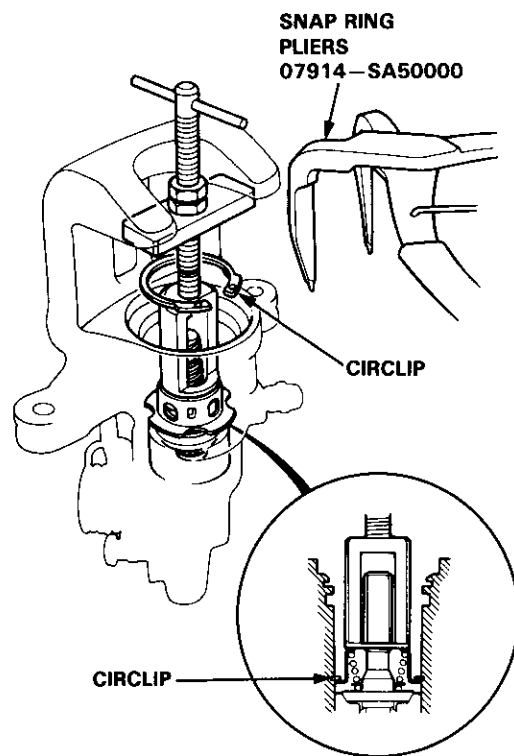

13. Coat a new piston seal with silicone grease and install it in the caliper.

14. Apply brake cylinder grease (P/N: 08733-B020E) or equivalent rubber grease to the sealing lips and inside of a new piston boot, and install it in the caliper.

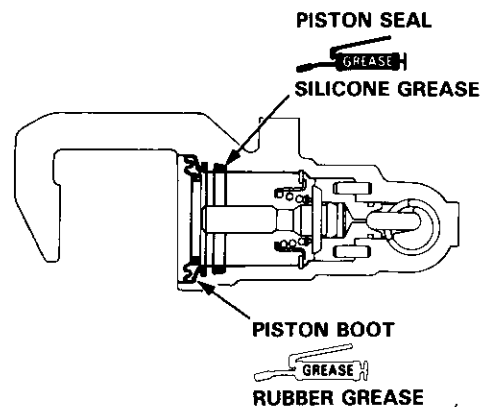

(cont'd)

Rear Caliper

Reassembly (cont'd)

15. Coat the outside of the piston with brake fluid and install it on the adjusting bolt while rotating it clockwise with the special tool.

CAUTION: Avoid damaging the piston and piston boot.

LOCKNUT WRENCH
07916-6390001

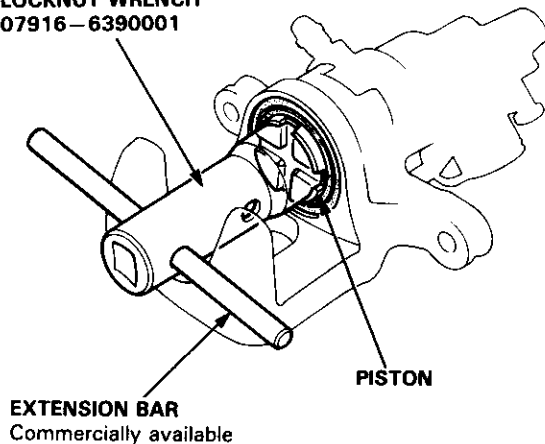

16. Install the pad spring on the caliper.

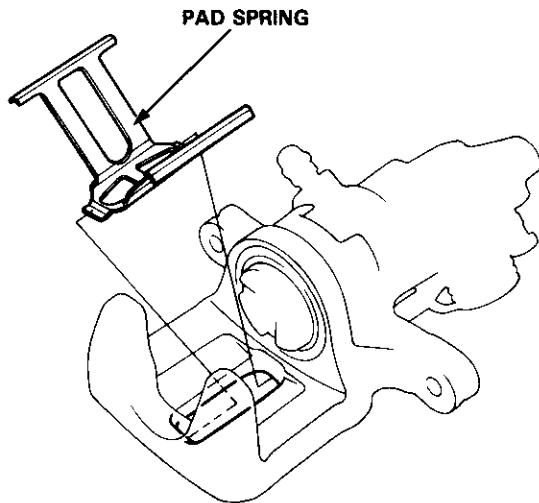

17. Install the brake pad retainers and brake pads.
18. Align the cutout in the piston with the tab on the inner pad (see page 19-19).

19. Install the caliper on the caliper bracket and tighten the caliper mounting bolts.

20. Connect the brake hose to the caliper with new sealing washers and tighten the banjo bolt.

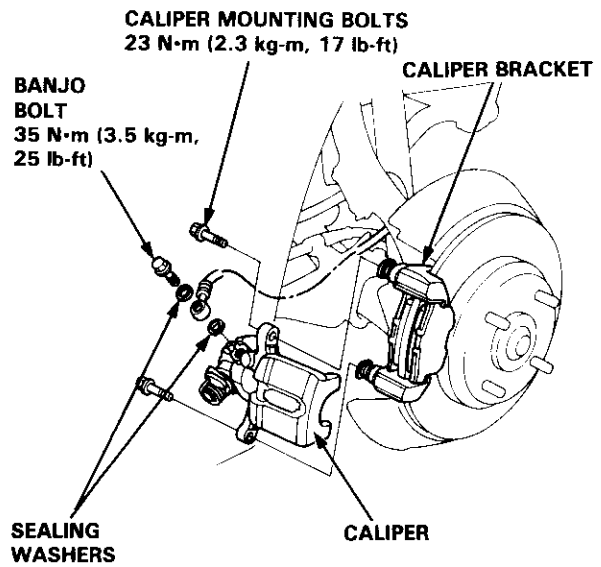

21. Insert the parking brake cable through the arm and connect the parking brake cable to the lever with the clevis pin and lock pin. Install the cable clip securely.

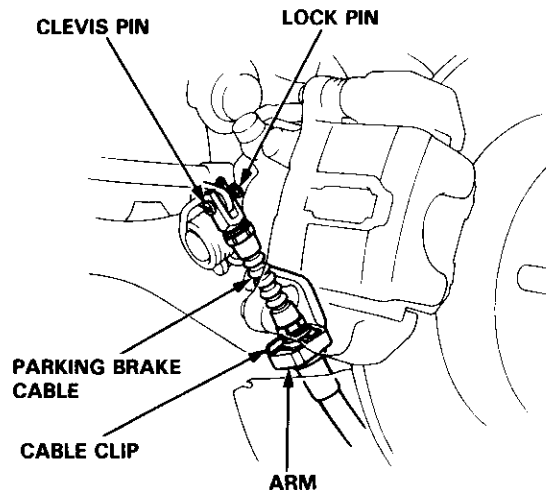

22. Fill the brake reservoir up and bleed the brake system (see page 19-12).

23. Operate the brake pedal several times, then adjust the parking brake (see page 19-5).



Brake Hoses/Pipes

Inspection

1. Inspect the brake hoses for damage, leaks, interference or twisting.
2. Check the brake lines for damage, tipping, rusting or leakage. Also check for bent brake lines.
3. Check for leaks at hose and line joints or connections, and retighten if necessary.

CAUTION: Replace the brake hose clip whenever the brake hose is serviced.

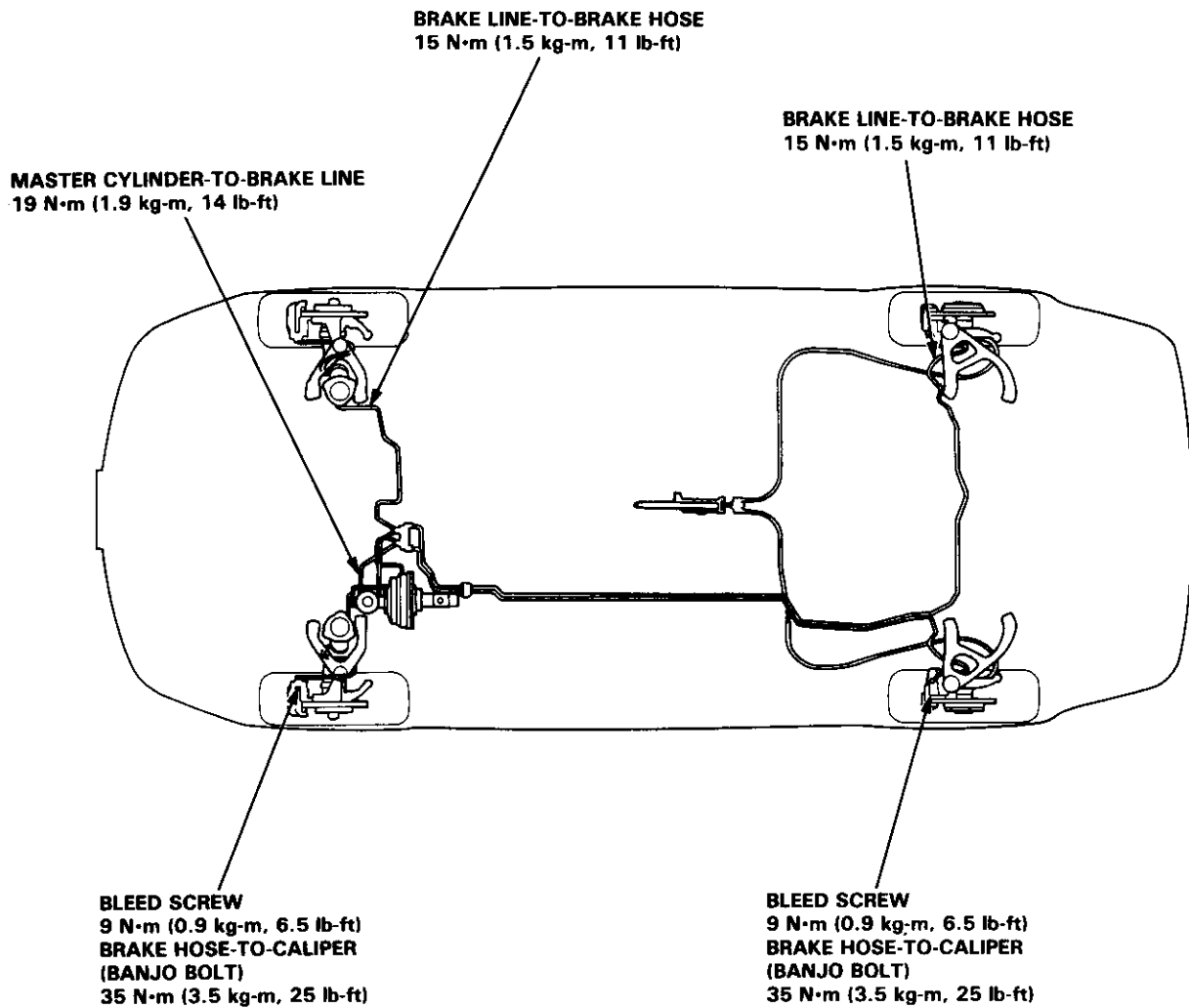

Brake Hoses/Pipes

Brake Hose Replacement

CAUTION:

- Before reassembling, check that all parts are free of dust and other foreign particles.
- Replace parts with new ones whenever specified to do so.
- Use only clean DOT 3 or DOT 4 brake fluid.
- Make sure no dirt or other foreign matter is allowed to contaminate the brake fluid.
- Do not mix different brands of brake fluid as they may not be compatible.
- Do not spill brake fluid on the car; it may damage the paint; if brake fluid does contact the paint, wash it off immediately with water.

1. Replace the brake hose if the hose is twisted, cracked or if it leaks.
2. Disconnect the brake hose from the brake pipe using a 10 mm flare nut wrench.

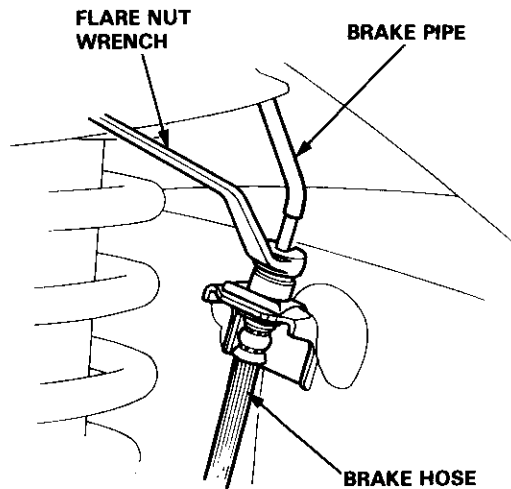

3. Remove and discard the brake hose clip from the brake hose.
4. Remove the banjo bolt and disconnect the brake hose from the caliper.
5. Remove the brake hose clamp bolts and the brake hose.

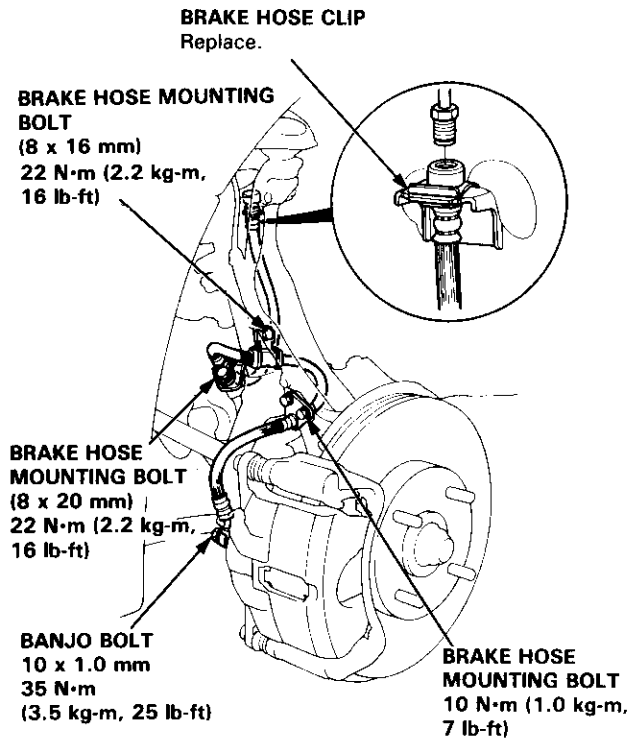

6. Install a new brake hose with the brake hose clamp bolts.
7. Connect the brake hose to the caliper with the banjo bolt and new sealing washers.
8. Install a new brake hose clip on the brake hose.
9. Connect the brake hose to the brake pipe.

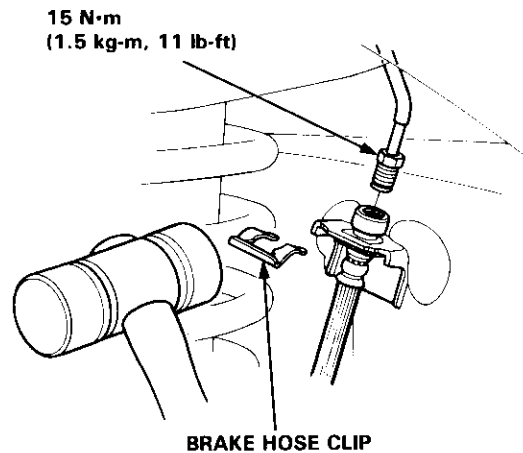

10. After installing the brake hose, bleed the brake system (see page 19-12), check the hose and line joints for leaks, and tighten if necessary.



Parking Brake

Disassembly and Reassembly

CAUTION: The parking brake cables must not be bent or distorted. This will lead to stiff operation and premature cable failure.

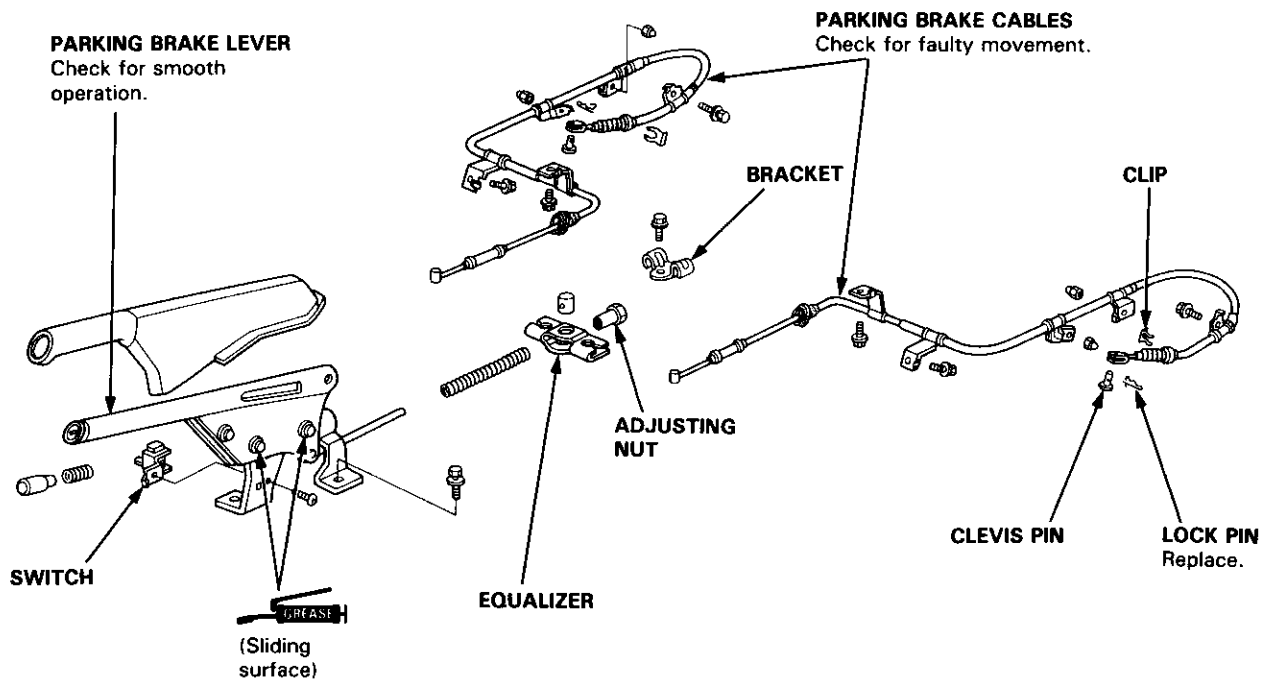

Disconnect the parking brake cable from the lever on the caliper by removing the lock pin and clevis pin, and remove the cable from the arm by removing the clip.

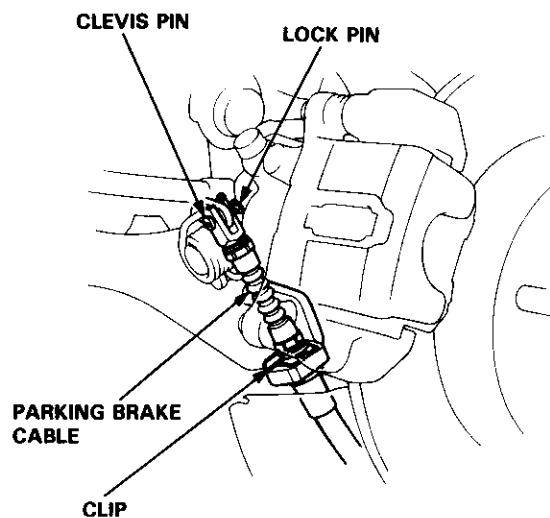

Anti-lock Brake System (ABS)

Special Tools	19-32	Modulator Unit	
Illustrated Index	19-33	Removal/Installation	19-82
Anti-lock Brake System (ABS)		Index/Torque	19-83
Features/Construction/		Solenoids	
Operation	19-34	Leak Test	19-84
Circuit Diagram	19-46	Pump	
Wiring/Connector Locations	19-50	Pressure Switch Replacement	19-84
ALB Checker		Accumulator	
Function Test	19-51	Disposal	19-85
Wheel Sensor Signal		Bleeding	19-86
Confirmation	19-53	Electronic Components	
Troubleshooting		ABS Control Unit Replacement	19-87
Anti-lock Brake System (ABS)		Relay Inspection	19-87
Indicator Light	19-54	Pulsers/Wheel Sensors	
Symptom-to-System Chart	19-56	Inspection	19-88
Flowcharts	19-57	Wheel Sensor Replacement	19-89
Hydraulic System			
Index Hydraulic Connections	19-80		
Relieving Accumulator/			
Line Pressure	19-81		



Special Tools

Ref. No.	Tool Number	Description	Qty	Page Reference
①	07HAA-SG00101 or 07HAA-SG00100	Bleeder T-wrench	1	19-57, 19-64, 19-81, 19-86
②	07HAJ-SG0010A or 07HAJ-SG0010B 07HAJ-SG00200	ALB Checker ALB Checker (Canada)	1 1	19-51, 19-53, 19-86

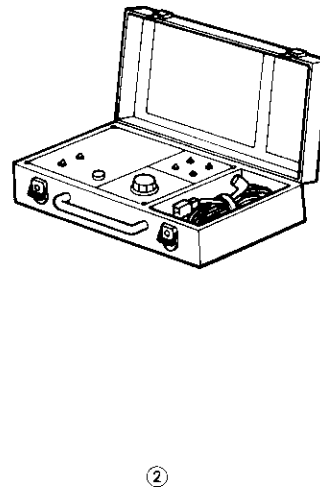
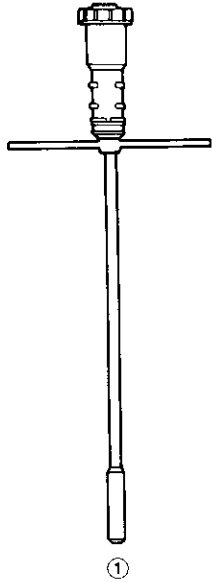

Illustrated Index



⚠ WARNING The accumulator contains high-pressure nitrogen gas, do not puncture, expose to flame or attempt to disassemble the accumulator or it may explode; severe personal injury may result.

MODULATOR UNIT

Hydraulic Connection, page 19-80
Removal/Installation, page 19-82
Index/Torque, page 19-83
Accumulator, page 19-85

HYDRAULIC SYSTEM

Relieving Accumulator/Line
Pressure, page 19-81
Bleeding, page 19-86

ABS CONTROL UNIT

Replacement, page 19-87

REAR WHEEL SENSOR

Inspection, page 19-88
Replacement, page 19-89

BRAKE HOSES/PIPES

Inspection, page 19-27
Brake Hose Replacement,
page 19-28

PARKING BRAKE

Adjustment, page 19-5
Disassembly and
Reassembly, page 19-29

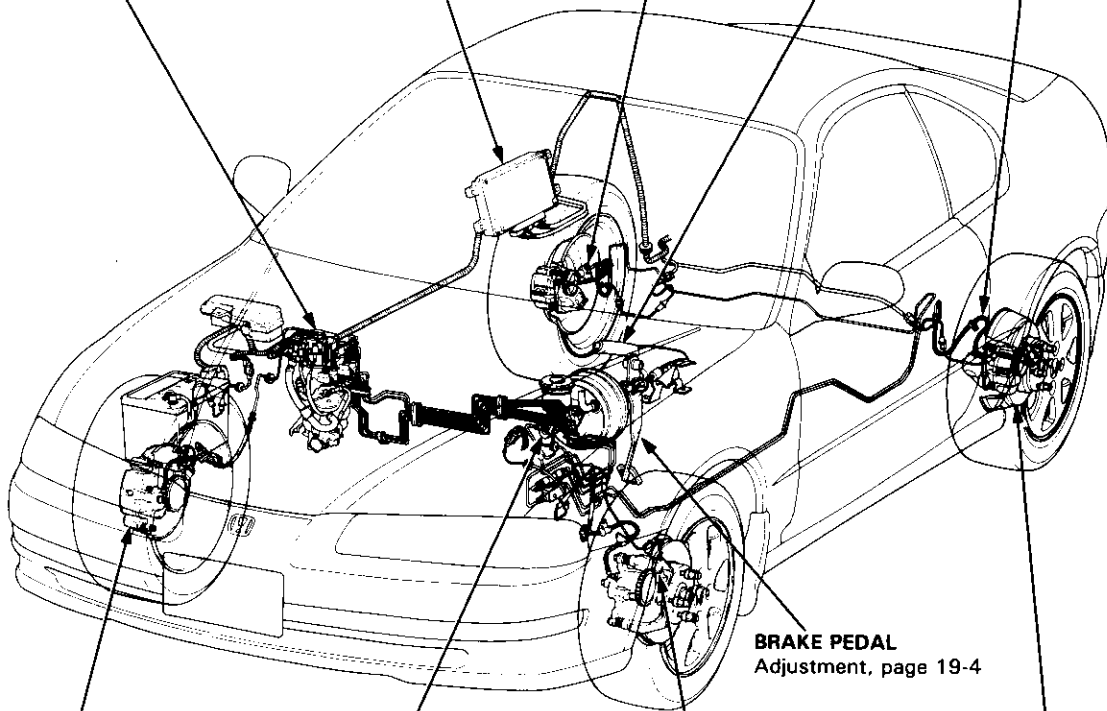

FRONT BRAKES

Torque/Inspection, page 19-6
Front Brake Pads, page 19-7
Front Caliper, page 19-9
Front Brake Disc, page 19-11

MASTER CYLINDER AND BRAKE BOOSTER

Hydraulic Connection, page 19-80
Master Cylinder, page 19-14
Brake Booster, page 19-15

BRAKE PEDAL

Adjustment, page 19-4

FRONT WHEEL SENSOR

Inspection, page 19-88
Replacement, page 19-89

REAR DISC BRAKES

Torque/Inspection, page 19-17
Rear Brake Pads, page 19-18
Rear Brake Disc, page 19-20
Rear Caliper, page 19-21

Anti-lock Brake System (ABS)

Features/Construction/Operation

In a conventional brake system, if the brake pedal is depressed very hard, the wheels can lock before the vehicle comes to a stop. In such a case, the stability of the vehicle is reduced if the rear wheels are locked, and maneuverability of the vehicle is reduced if the front wheels are locked, creating an extremely unstable condition.

The Anti-lock Brake System (ABS) modulates the pressure of the brake fluid applied to each front caliper or both rear calipers thereby preventing the locking of the wheels, whenever the wheels are likely to be locked due to hard braking. It then restores normal hydraulic pressure when there is no longer any possibility of wheel locking.

Features

- Increased braking stability can be achieved regardless of changing driving conditions.
- The maneuverability of the vehicle is improved as the system prevents the front wheels from locking.
- When the anti-lock brake system goes into action, a kickback is felt on the brake pedal.
- The system is equipped with a self-diagnosis function. When an abnormality is detected, the ABS indicator light comes on. The location of the system's trouble can be diagnosed from the frequency of the system indicator light blinks.
- This system has individual control of the front wheels and common control ("Select Low") for the rear wheels. "Select Low" means that the rear wheel that would lock first (the one with the lowest resistance to lock-up) determines anti-lock brake system activation for both rear wheels.
- The system has a fail-safe function that allows normal braking if there's a problem with the anti-lock brake system.

Construction

In addition to the conventional braking system, the anti-lock brake system consists of: gear pulsers attached to the rotating part of individual wheels; wheel sensors, which generate pulse signals corresponding to the revolution of the gear pulsers; ABS control unit, which controls the working of the anti-lock brake system by performing calculations based on the signals from the individual wheel sensors and the individual switches; modulator unit, which adjusts the hydraulic pressure applied to each caliper on the basis of the signals received from the ABS control unit; an accumulator, in which high-pressure brake fluid is stored, a pressure switch, which detects the pressure in the accumulator and transmits signals to the ABS control unit; a power unit, which supplies the high-pressure working fluid to the accumulator by means of a pump; a motor relay for driving the power unit; fail-safe relays, which cut off the solenoid valve ground circuit when the fail-safe device is at work; and, an ABS indicator light.

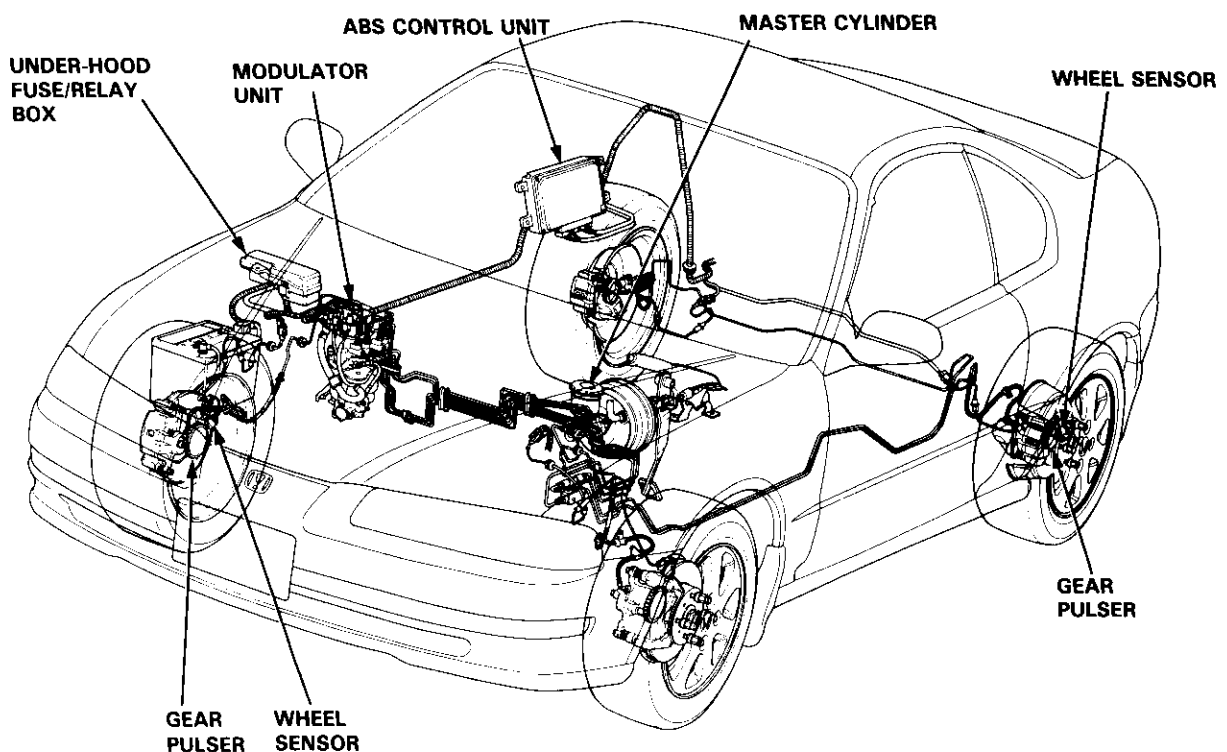



Master Cylinder

1. Construction

A tandem master cylinder is used to improve the safety of the braking system. In addition, center valves are used so as to match the anti-lock brake system operation.

The master cylinder has one reservoir tank which is connected to the cylinder sections by two small holes. It has two pistons: primary and secondary, which are crisscross connected with the calipers so that the fluid pressure works separately on each system (front right wheel & rear left wheel, and front left wheel & rear right wheel).

A stop bolt for controlling movement of the primary piston is provided at the side of the master cylinder body. A reed switch for detecting the brake fluid volume is also provided in the cap of the reservoir tank.

2. Operation

When the brake pedal is depressed, the secondary piston is pushed through the brake booster and the center valve B is closed so that fluid pressure is generated on the secondary side. At the same time, the primary piston is pushed by the secondary fluid pressure and the center valve A is closed so that braking fluid pressure is generated both on the primary and secondary sides.

When the brake pedal is released, the primary and secondary pistons are returned to the original position by the brake fluid pressure and piston spring.

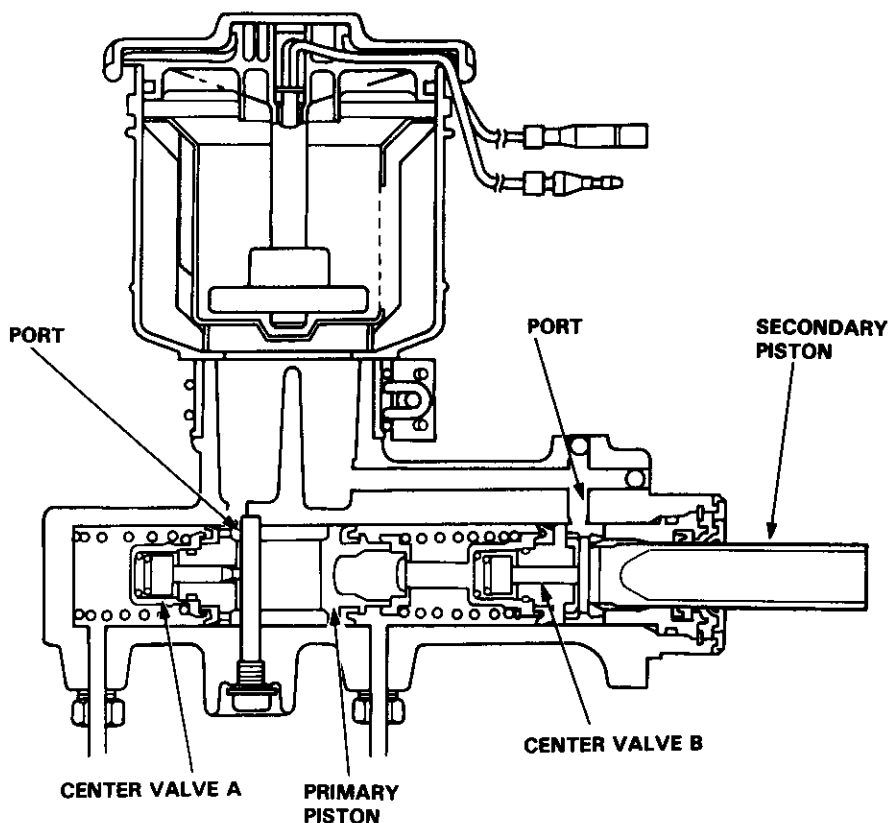

(cont'd)

Anti-lock Brake System (ABS)

Features/Construction/Operation (cont'd)

3. Responses when fluid is leaking

(1) In case of leaking from the primary system:

Since the fluid pressure on the primary side does not rise, the primary piston is pushed by the fluid pressure of the secondary piston and the tension of the piston spring until the end hits on the cylinder. The braking is performed by the fluid pressure on the secondary side.

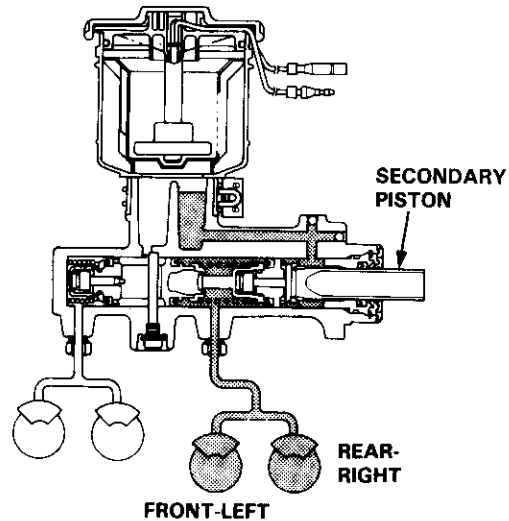

(2) In case of leaking from the secondary system:

The secondary piston does not produce fluid pressure, keeps moving ahead, hits on the end surface of the primary piston so that the primary piston is pushed under the same condition as an ordinary rod. Therefore, the braking is conducted by the fluid pressure on the primary side.

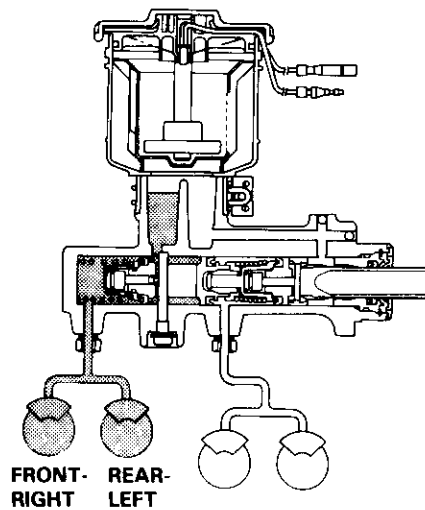

Wheel Sensor

The wheel sensor is a contactless type that detects the rotating speed of a wheel. It is comprised of a permanent magnet and coil. When the gear pulsers attached to the rotating parts of each wheel (front wheel: outboard joint of the driveshaft, rear: hub bearing unit) turn, the magnetic flux around the coil in the wheel sensor alternates, generating voltages with frequency in proportion to wheel rotating speed. These pulses are sent to the ABS control unit and the ABS control unit identifies the wheel speeds.

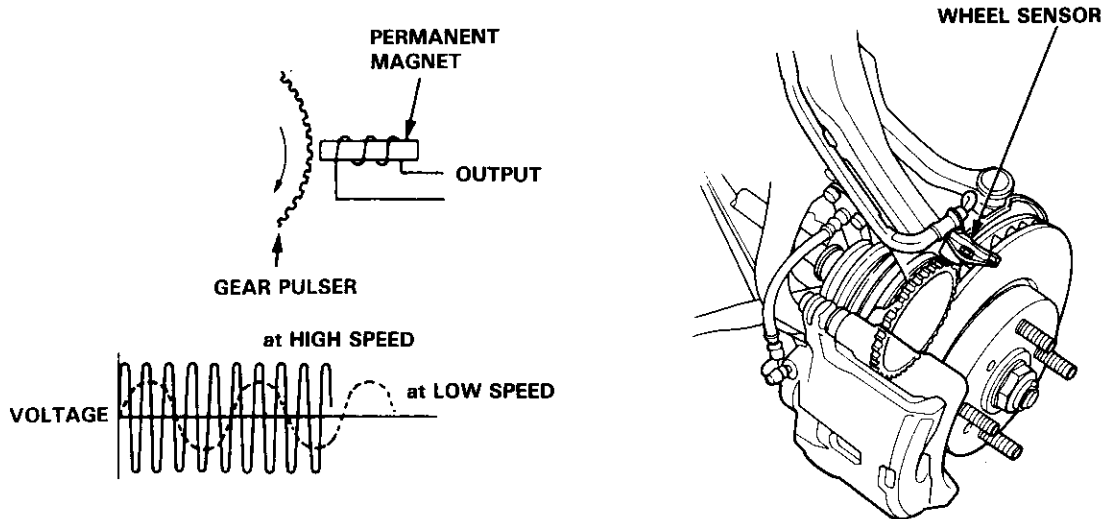

ABS Control Unit

The ABS control unit consists of a main function section, which controls the operation of the anti-lock brake system, and subfunction, which controls the pump motor and "self-diagnosis".

1. Main Function

The main function section of the ABS control unit performs calculations on the basis of the signals from each wheel sensor and controls the operation of the anti-lock brake system by putting into action the solenoid valves in the modulator unit for each front brake and for the two rear brakes.

2. Sub-function

The sub-function section gives driving signals to the pump motor and also gives "self-diagnosis" signals, necessary for backing up the anti-lock brake system.

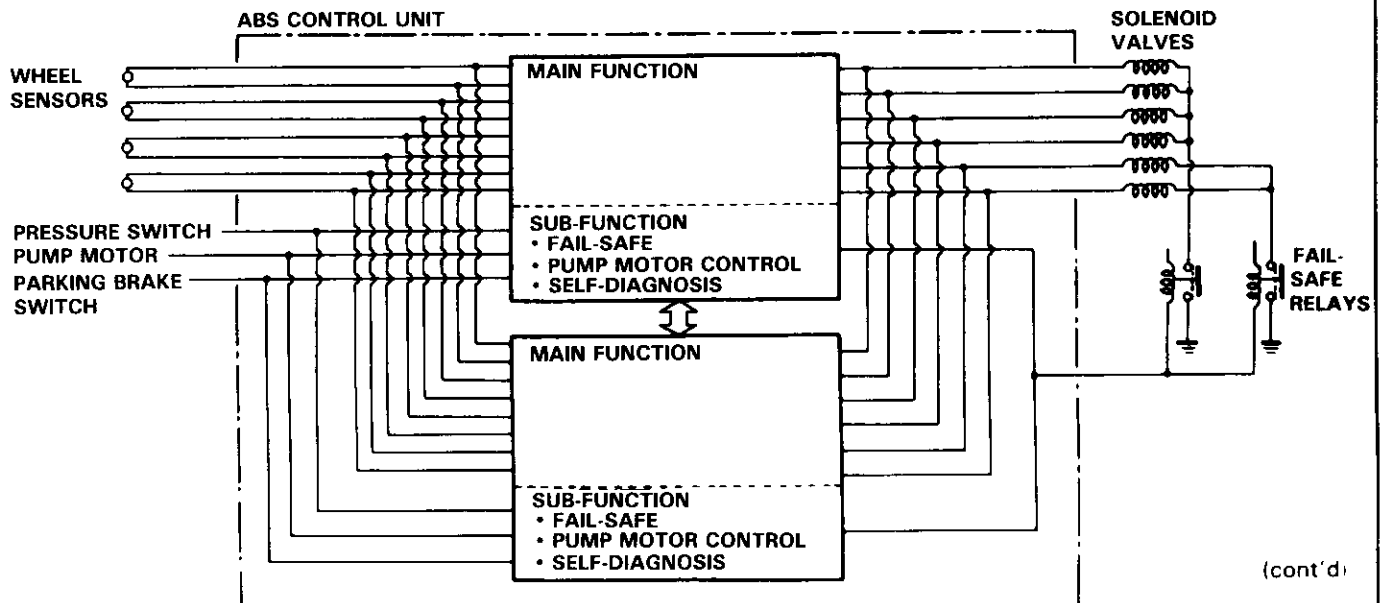

(cont'd)

Anti-lock Brake System (ABS)

Features/Construction/Operation (cont'd)

1. Self-diagnostic Function

Since the anti-lock brake system modulates the braking pressure when a wheel is about to lock, regardless of the driver's intention, the system operation and the braking power will be impaired if there is a malfunction in the system. To prevent this possibility, at speeds above 6 mph (10 km/h), the self-diagnosis function, provided in the sub-function of the ABS control unit, monitors the main system functions. When an abnormality is detected, the ABS indicator light goes on. There is also a check mode of the self-diagnosis system itself; when the ignition switch is first turned on, the ABS indicator light comes on and stays on for a few seconds after the engine starts, to signify that the self-diagnosis system is functional.

2. Fail-safe Function

When abnormality is detected in the control system by the self-diagnosis, the solenoid operations are suspended by turning off the relays (fail-safe relays) which disconnect the ground lines of all the solenoid valves to inhibit anti-lock brake system operations. Under these conditions, the braking system functions just as an ordinary one, maintaining the necessary braking function. When the ABS indicator light is turned on, it means the fail-safe is functioning.

Modulator Unit

Modulators for each wheel and solenoid valves are integrated in the modulator unit.

The modulators for front and rear brakes are of independent construction and are positioned vertically for improved maintainability. The modulators for rear brakes are provided with a PCV function (Proportioning Control Valve) in order to prevent the rear wheel from locking when the anti-lock brake system is malfunctioning or the anti-lock brake system is not activated.

The solenoid valve features quick response (5 ms or less).

The inlet and outlet valves are integrated in the solenoid valve unit. There are three solenoid valves provided, one for each front wheel, and one for the rear wheels.

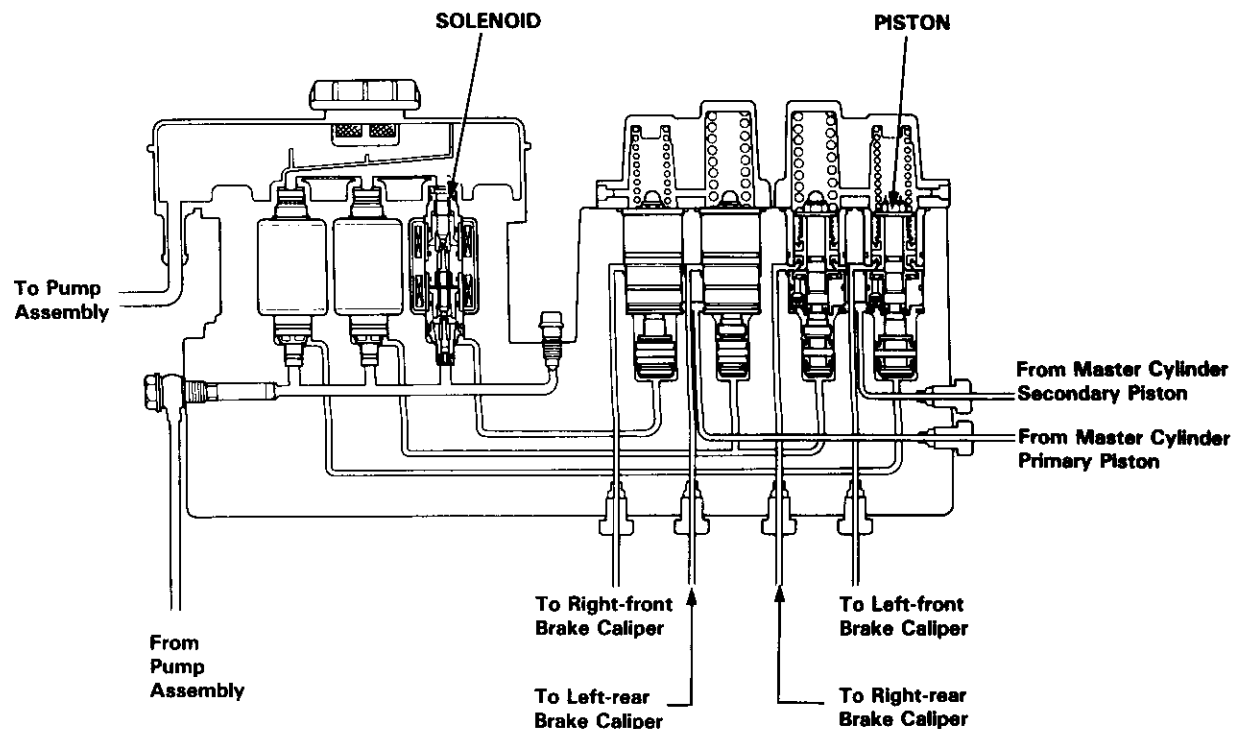



Accumulator

The accumulator is a pneumatic type which accumulates high-pressure brake fluid fed from the pump incorporated in the power unit. When the anti-lock brake system operates, the accumulator and the power unit supply high-pressure brake fluid to the modulator valve via the inlet side of the solenoid valve.

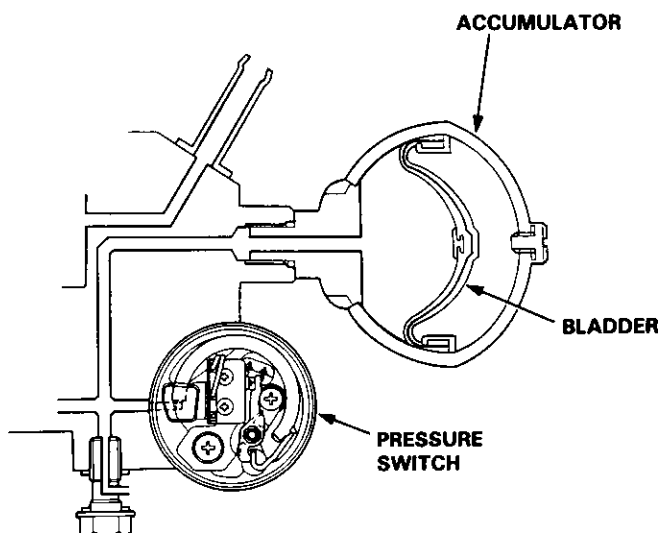

Pressure Switch

The pressure switch monitors the pressure accumulation (pressure from the pump) in the accumulator and is turned off when the pressure becomes lower than a prescribed level. When the pressure switch is turned off, the switching signal is sent to the ABS control unit. Upon receiving the signal, the ABS control unit activates the pump motor relay to operate the motor. If the pressure doesn't reach the prescribed value, the ABS indicator light comes on.

Operation

When the pressure in the accumulator rises, the Bourdon tube in the pressure switch deforms outwards. When the free end of the Bourdon tube moves more than the prescribed amount, the micro-switch is activated by the force of the spring attached to the sensing lever. When the pressure in the accumulator decreases due to anti-lock brake system operations, the Bourdon tube moves in the direction opposite to the one described above, and the micro-switch is eventually turned off. Upon receiving this signal, the ABS control unit activates the motor relay to operate the motor.

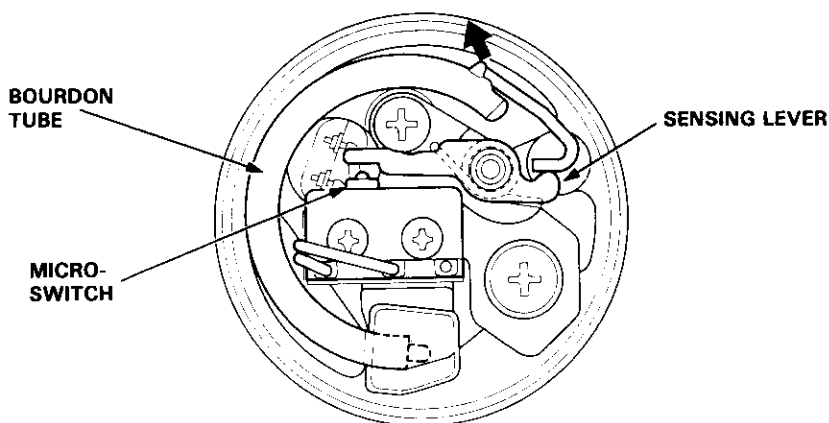

(cont'd)

Anti-lock Brake System (ABS)

Features/Construction/Operation (cont'd)

Power Unit

The power unit consists of a motor, filter, guide, piston rod and cylinder body. Since a guide is positioned offset to the center of the motor shaft, the rotation of the motor and cylinder body provides the reciprocating motion to the piston rod. The brake fluid is thus pressurized and fed to the relief valve, accumulator and modulator.

As the pressure in the accumulator exceeds the prescribed level, the pressure switch is turned on. Approx. 0.5 seconds after receiving the ON-signal, the ABS control unit stops the motor relay operation. In this state, the pressure in the accumulator reaches 23000 kPa (230 kg/cm², 3270 psi).

If the pressure doesn't reach the prescribed value after the motor has operated continuously for a specified period, the ABS control unit stops the motor and activates the ABS indicator light.

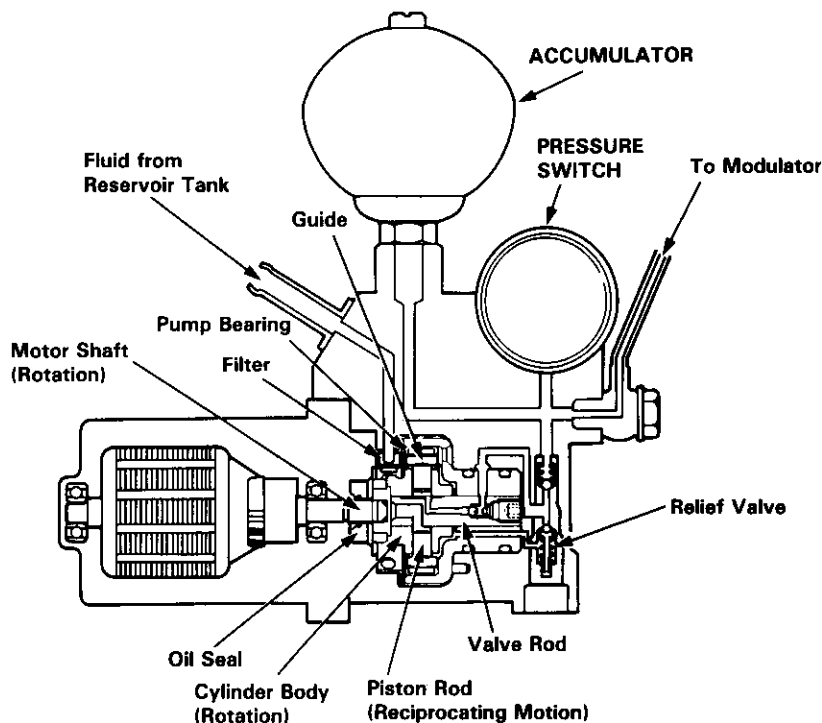

Anti-lock Brake System (ABS) Indicator Light

This warning system turns on the ABS indicator light when one or more of the below described abnormalities is detected. This is only a partial list.

- When the operating time of the motor in the power unit exceeds the specified period.
- When vehicle running time exceeds 30 seconds without releasing the parking brake lever.
- When one of the rear wheels is locked during running.
- When absence of speed signals from any of the four wheel sensors is detected.
- When the activation time of all solenoids exceeds a given time or an open or short circuit is detected in the solenoid system.
- When solenoid output is not detected in the simulated anti-lock brake system operation carried out during running at speeds of 6 mph (10 km/h) or more.

To check the ABS indicator light bulb, the light is activated when the ignition switch is turned on. It is turned off after the engine is started if there is no abnormality in the system.



Operation

1. Ordinary Braking Function

In ordinary brake operations, the cut-off valve in the modulator is open, transmitting the hydraulic pressure from the master cylinder to the brake calipers via chamber A and chamber B.

Chamber C is connected to the reservoir through the outlet valve, which is normally open. It is also connected to the hydraulic pressure source (pump, accumulator, pressure switch, etc.) via the inlet valve, which is normally closed. Chamber D serves as an air chamber. Under these conditions, the pressures of chambers C and D are maintained at about atmospheric pressure, permitting regular braking operations.

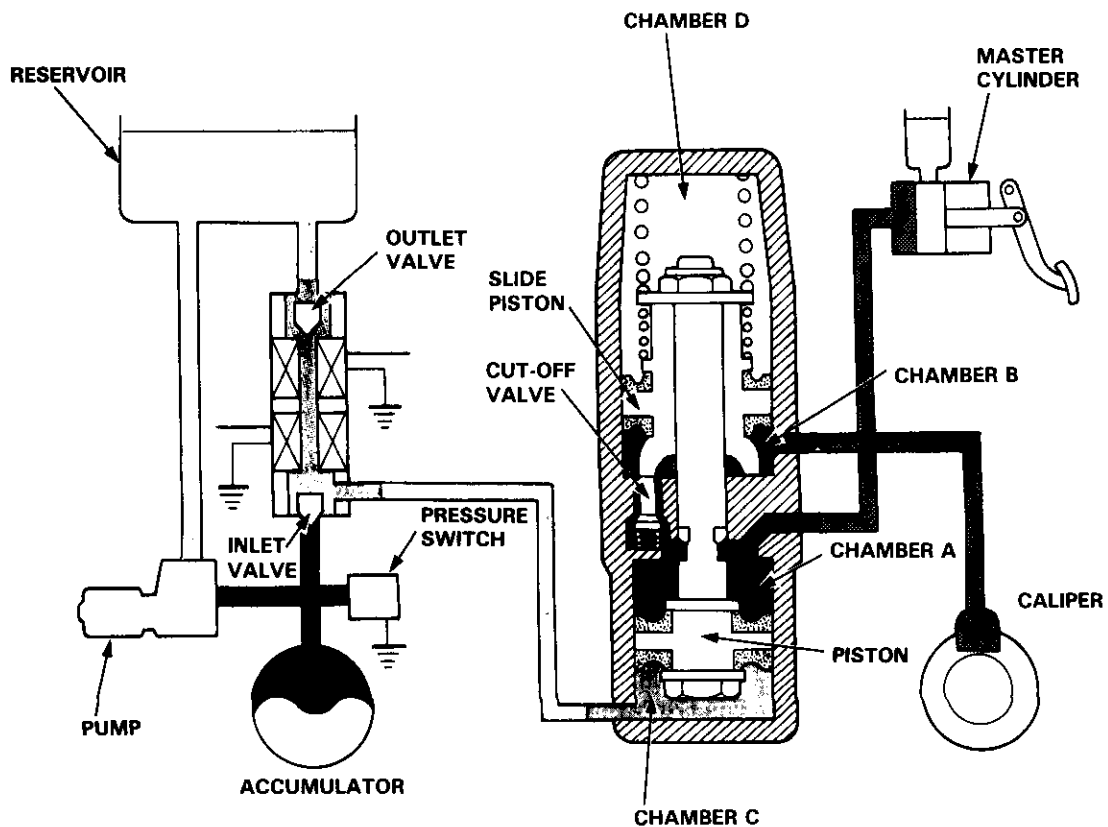

(cont'd)

Anti-lock Brake System (ABS)

Features/Construction/Operation (cont'd)

If brake inputs (force exerted on brake pedal) are excessively large and a possibility of wheel locking occurs, the ABS control unit operates the solenoid valve, closing the outlet valve and opening the inlet valve. As a result, the high pressure is directed into chamber C, the piston is pushed upward, causing the slide piston to move upward and the cut-off valve to close. As the cut-off valve closes, the flow from the master cylinder to the caliper is interrupted, the volume of chamber B, which is connected to the caliper, increases, and the fluid pressure in the caliper declines.

When both of the valves, inlet and outlet, are closed (when only the outlet valve is activated) the pressure in the caliper is maintained constant.

When the possibility of wheel locking ceases, it is necessary to restore the pressure in the caliper. The solenoid valve is therefore turned off (outlet valve: open, inlet valve: closed).

Process	Caliper Pressure	Outlet Valve		Inlet Valve	
		Electric Power	Hydraulic Circuit	Electric Power	Hydraulic Circuit
Caliper pressure declining	→	ON	Close	ON	Open
Caliper pressure constant	→	ON	Close	OFF	Close
Caliper pressure increasing	→	OFF	Open	OFF	Close

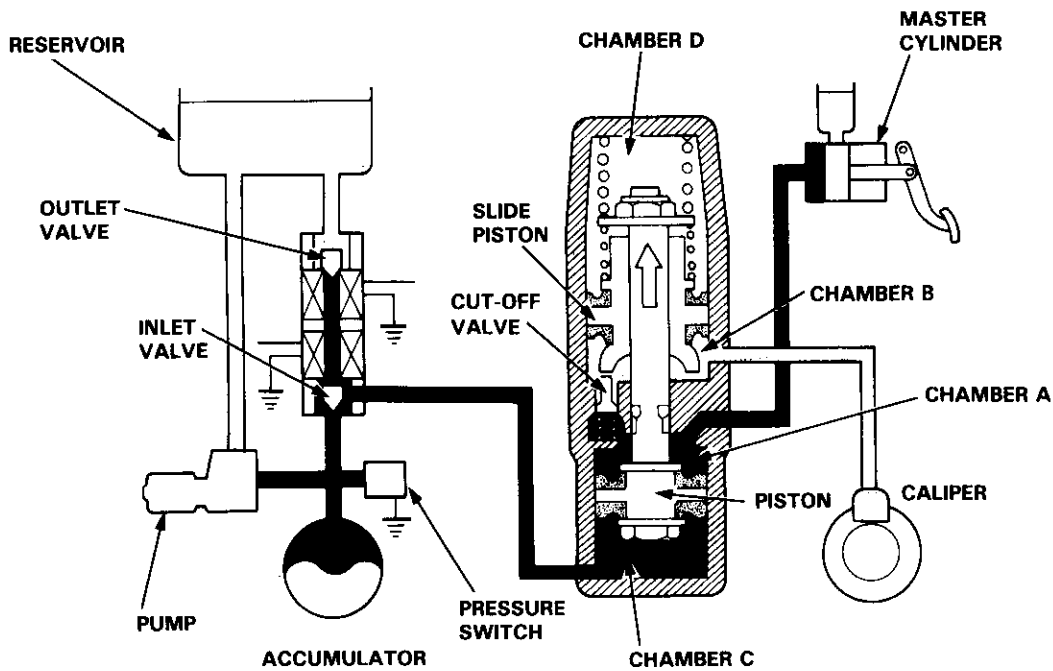



2. Slide Piston Function

When the car is used on rough roads where the tires sometimes lose adhesion, the anti-lock brake system may function excessively, causing a very large volume of brake fluid to flow into chamber C. When this occurs, the piston is moved excessively, resulting in an abnormal loss of pressure in chamber B. In order to overcome this problem, the slide piston is kept in proper position by spring force to prevent the pressure in chamber B from becoming negative.

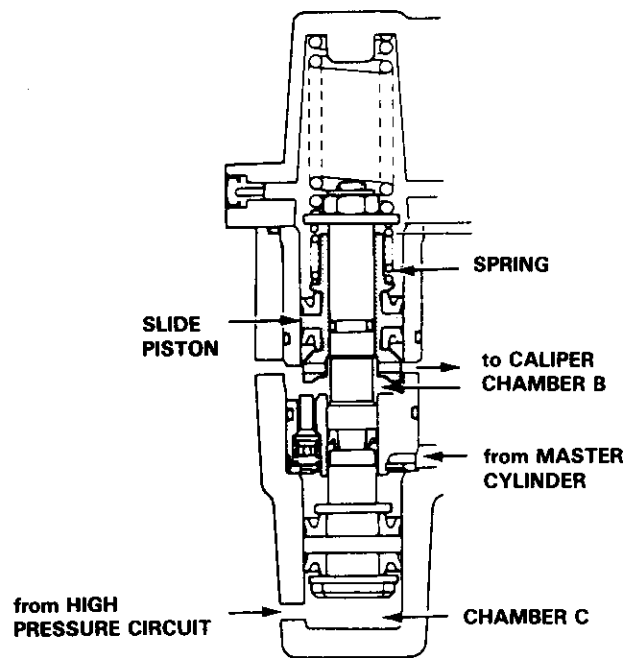

(cont'd)

Anti-lock Brake System (ABS)

Features/Construction/Operation (cont'd)

3. Kickback

When the anti-lock brake system is functioning, the piston moves upward, the volume of chamber B increases, and the fluid pressure on the caliper side is reduced. At the same time, the volume of chamber A is reduced and the brake fluid is returned to the master cylinder. When the brake fluid is pushed back to the master cylinder, the driver can feel the functioning of the anti-lock brake system because the brake pedal is kicked back.

4. PCV (Proportioning Control Valve) Function

In the modulator for the rear wheels, the diameters of the piston and the slide piston are distinctly different. This provides a PCV (Proportioning Control Valve) function to prevent the rear wheels from locking during an emergency stop.

(1) Before the Turning Point:

1) When the fluid pressure from the master cylinder is below the turning point, the cut-off valve is always pushed downward by the force of the slide piston and its spring.

Under these conditions, there is a gap between the cut-off valve shoulder and the sleeve. Chamber A and chamber B are therefore connected through the gap. The pressure from the master cylinder flows into the rear calipers through chamber A and chamber B.

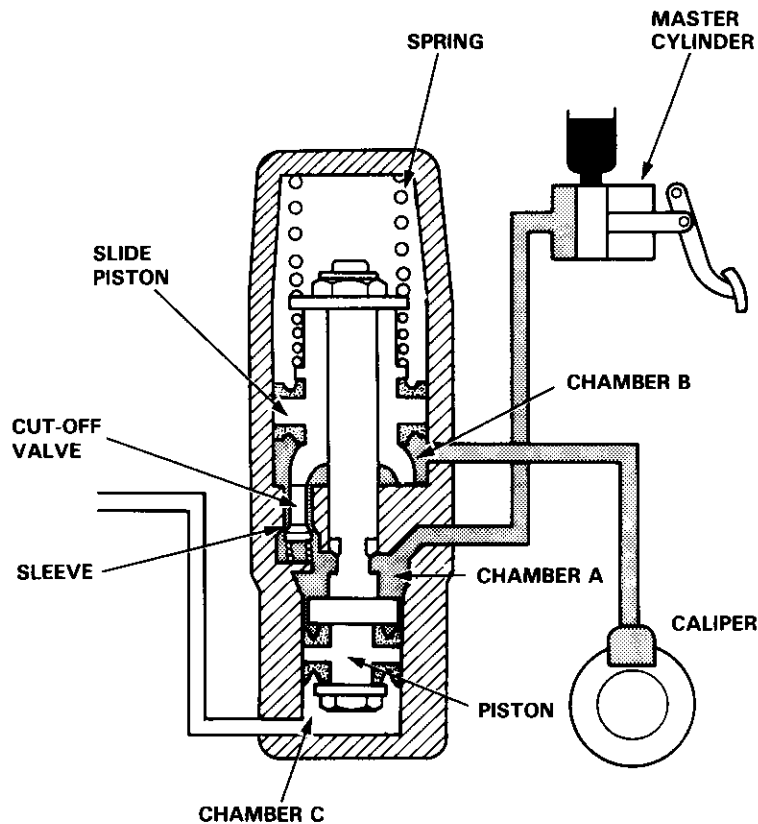



- 2) When the fluid pressure from the master cylinder reaches the turning point, the force on the slide piston overcomes the force of the spring, causing the slide piston to travel upward. The cut-off valve, previously being in contact with the bottom of the slide piston, then moves upward and the cut-off valve shoulder hits the sleeve, blocking the fluid passages (the fluid pressure at this point is called the turning point).

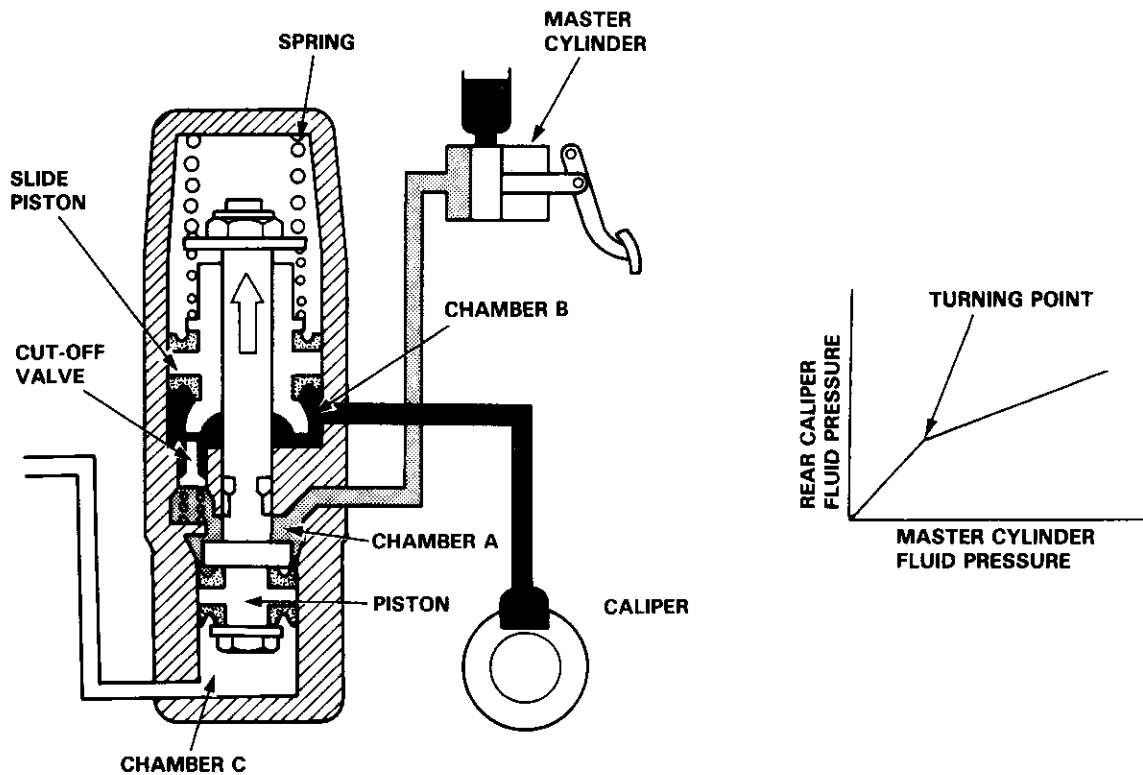

- (2) After the turning point:
As the fluid pressure from the master cylinder increases, the pressure in chamber A becomes higher, causing a force to push down the large diameter portion of the piston. Consequently, the slide piston comes down, the cut-off valve is pushed downward by the bottom of the slide piston, allowing chambers A and B to connect momentarily. As this occurs, pressure in chamber B increases, the slide piston is pushed upward, the cut-off valve goes up, and the connection between chamber A and chamber B is blocked again. As described above, when the pressure in the master cylinder is above the turning point, the slide piston reduces the pressure in the rear caliper to the prescribed amount by repeating this process.

Circuit Diagram (2WS)

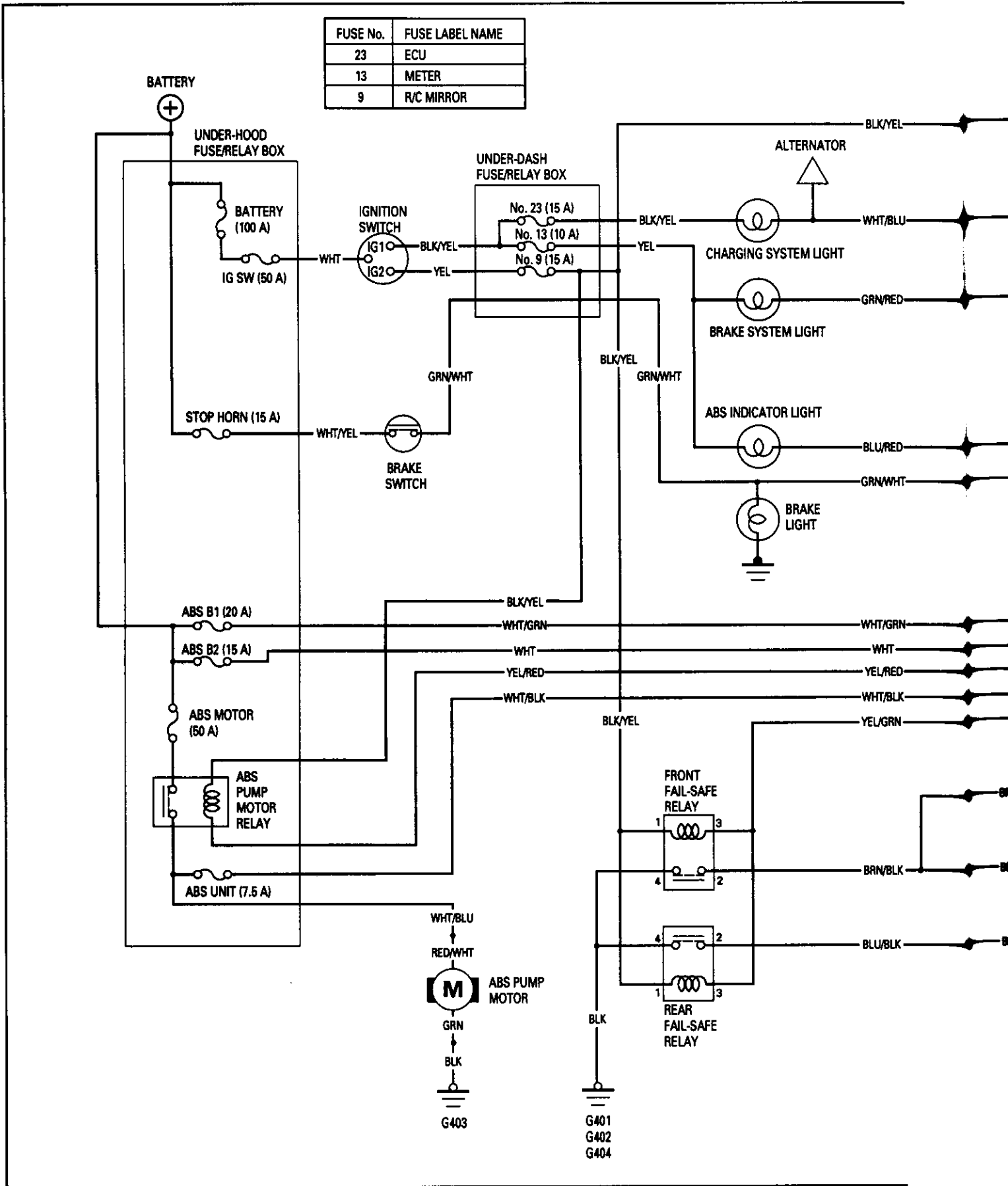

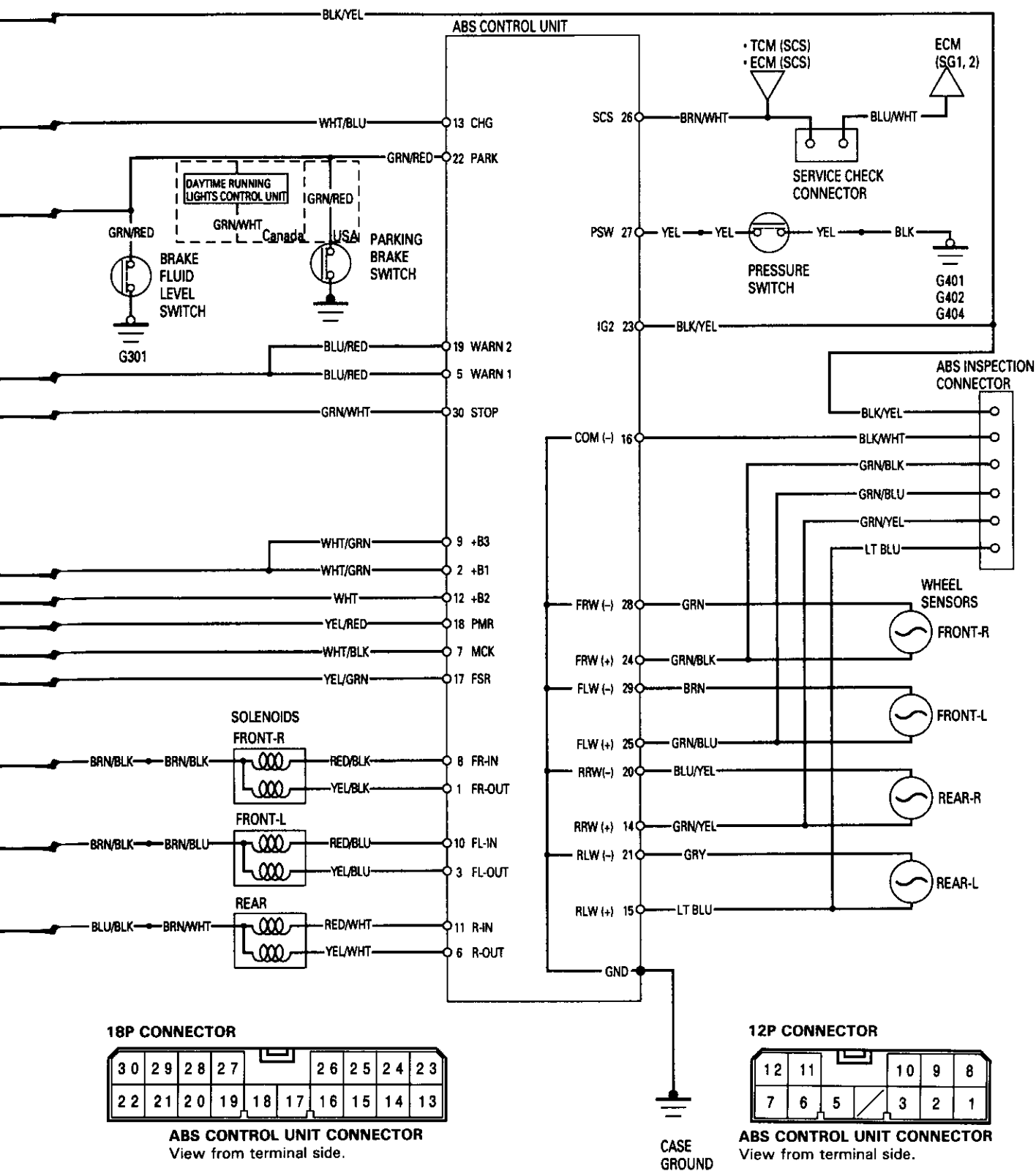

Circuit Diagram (4WS)

FUSE No.	FUSE LABEL NAME
23	ECU
13	METER
9	R/C MIRROR

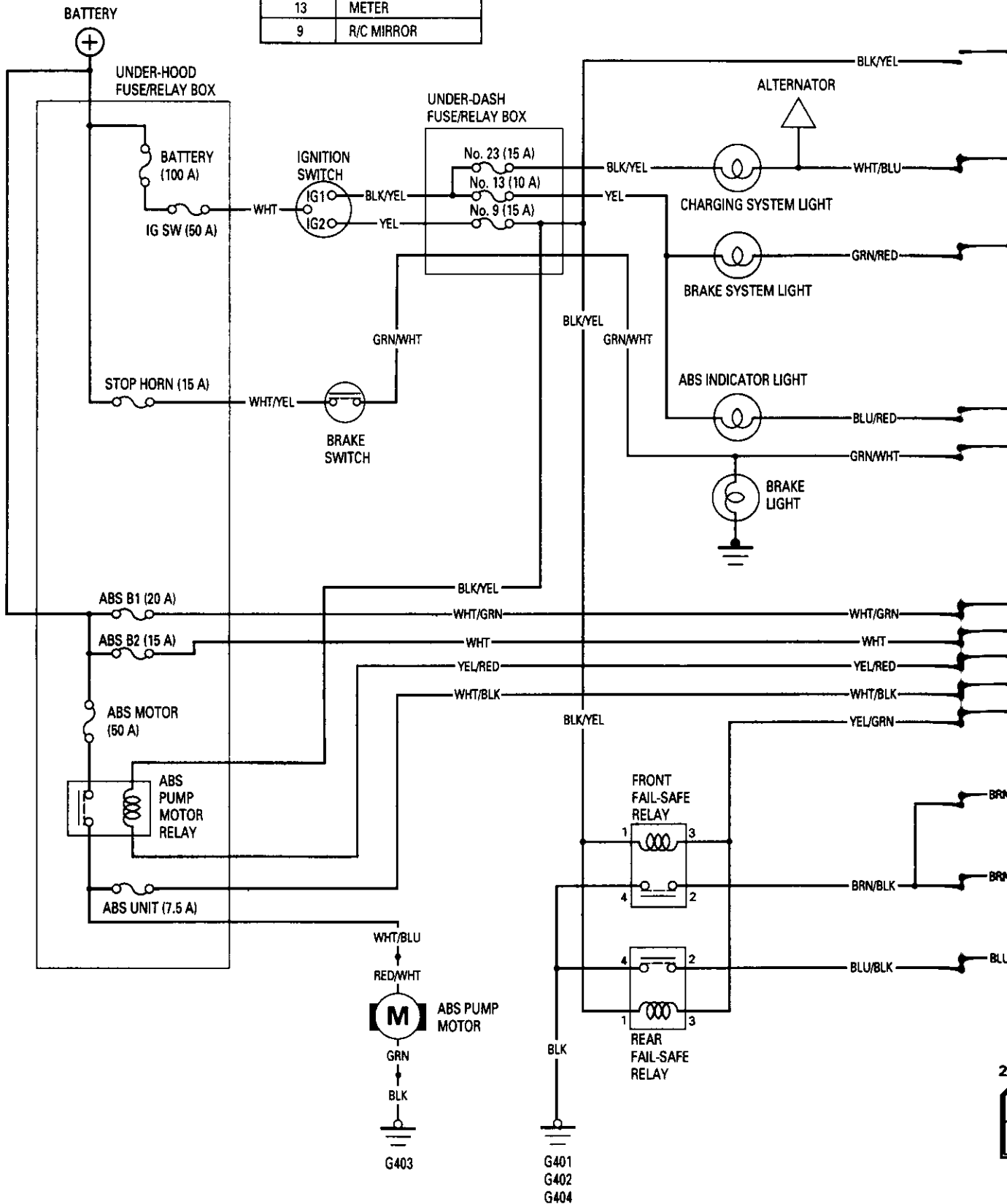

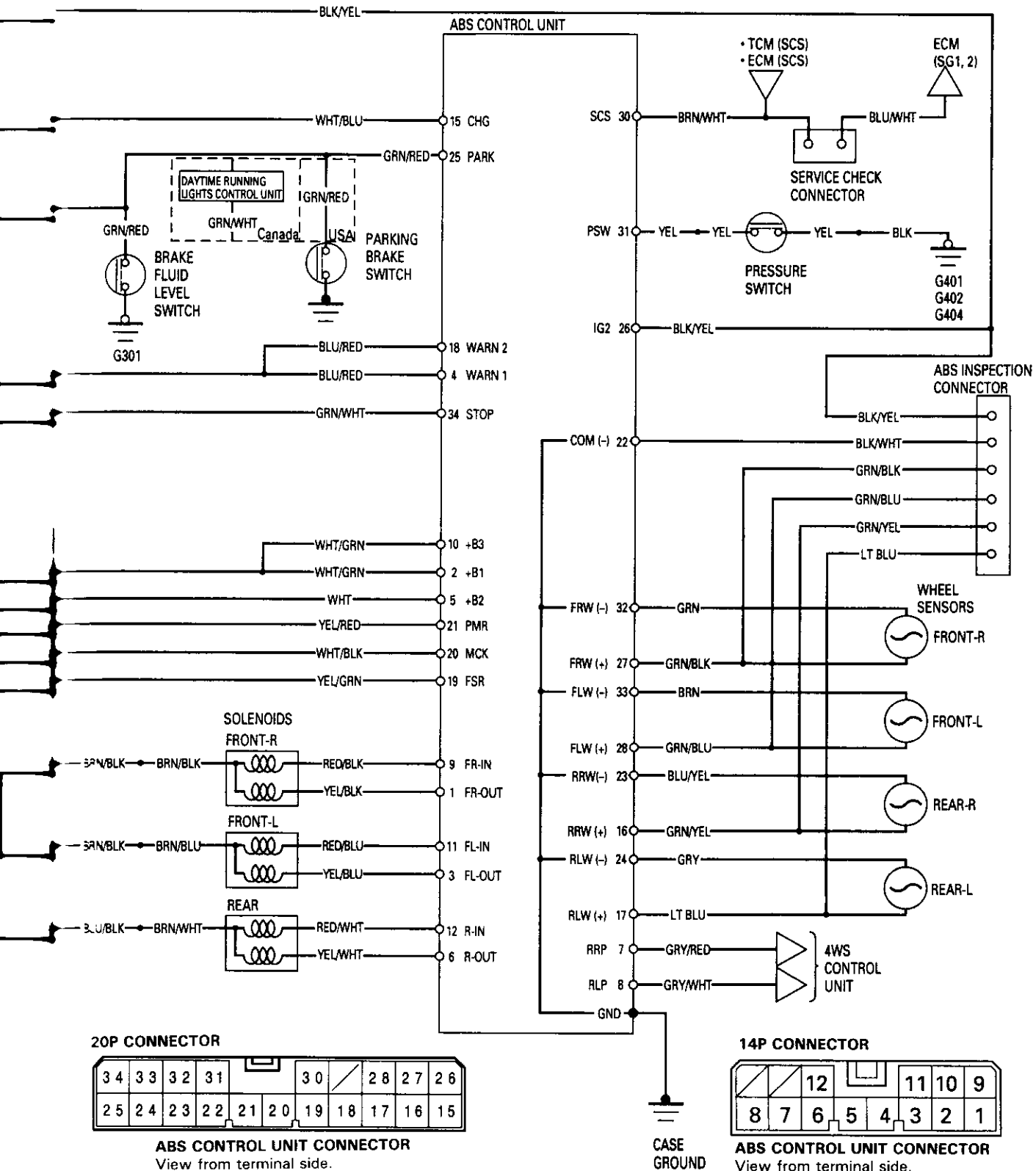

Wiring/Connector Locations

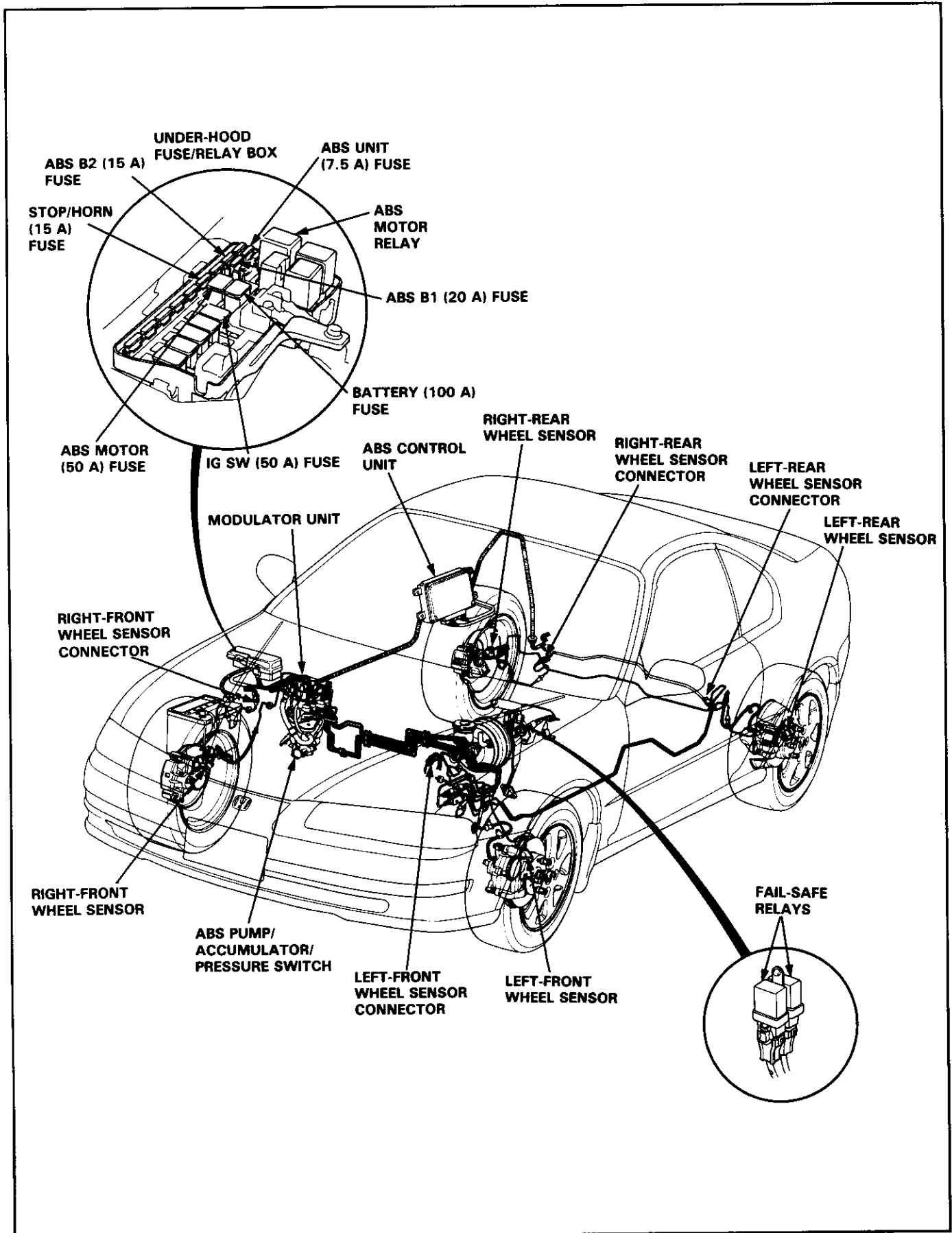

ALB Checker

Function Test



NOTE:

- The ALB checker is designed to confirm proper operation of the anti-lock brake system (ABS) by simulating each system function and operating condition. Before using the checker, confirm that the anti-lock brake system (ABS) indicator light is not indicating some other problem with the system. The light should go on when the ignition is first turned on and then go off and stay off one second after the engine is started.
- The checker should be used through modes 1–5 to confirm proper operation of the system in any one of the following situations:
 - After replacing any ABS component.
 - After replacing or bleeding the system fluid (0 mode not necessary).
 - After any body or suspension repair that may have affected the sensors or their wiring.
- The procedure for modes 1–5 are on this page and 19-52, mode "0" (wheel sensor signal) is on page 19-53.

⚠ WARNING Disconnect the ALB checker before driving the car. A collision can result from a reduction, or complete loss, of braking ability causing severe personal injury or death.

1. With the ignition switch off, disconnect the ABS inspection connector (6P) from the connector cover located on the cross-member under the passenger's seat and connect the ABS inspection connector (6P) to the ALB checker.

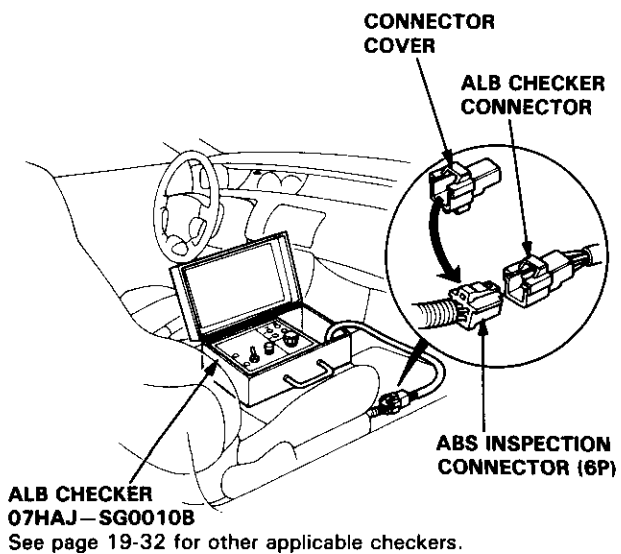

NOTE: Place the vehicle on level ground with the wheels blocked, put the transmission in neutral for manual transmission models, and in **P** position for automatic transmission models.

2. Start the engine and release the parking brake.
3. Operate the ALB checker as follows:
 - (1) Turn the Mode Selector switch to "1".
 - (2) Push the Start Test switch:
 - The test in progress light should come ON.
 - In one or two more seconds, all four monitor lights should come on (if not the checker is faulty).
 - The ABS indicator light should not come ON.

NOTE: When the test in progress indicator light is ON, don't turn the Mode Selector switch.

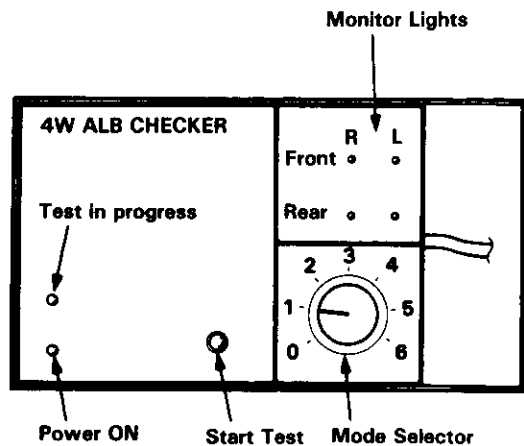

4. Turn the Mode Selector Switch to "2".

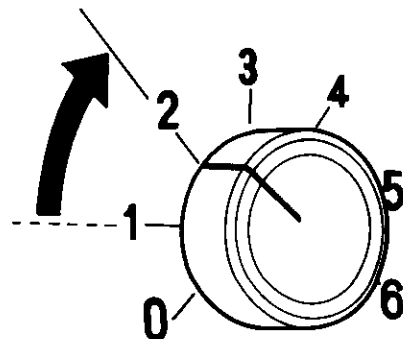

(cont'd)

ALB Checker

Function Test (cont'd)

5. Depress the brake pedal firmly and push the Start Test switch.
The ABS indicator light should not go on while the Test in Progress light is ON. There should be kickback on the brake pedal.

NOTE: The operation sequence simulated by Modes 2, 3, 4 and 5:

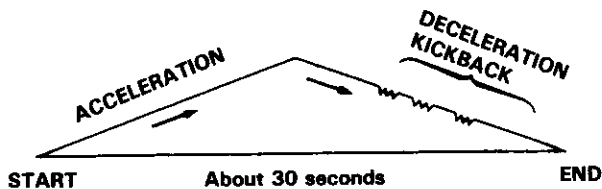

6. Turn the Mode Selector switch to "3", "4" and "5".
Perform step 5 for each of the test mode positions.

Mode 1:

Sends the simulated driving signal 0 mph (0 km/h) → 113 mph (180 km/h) → 0 mph (0 km/h) of each wheel to the ABS control unit. There should be NO kickback.

Mode 2:

Sends the driving signal of each wheel, then sends the lock signal of the left rear wheel to the ABS control unit. There should be kickback.

Mode 3:

Sends the driving signal of each wheel, then sends the lock signal of the right rear wheel to the ABS control unit. There should be kickback.

Mode 4:

Sends the driving signal of each wheel, then sends the lock signal of the left front wheel to the ABS control unit. There should be kickback.

Mode 5:

Sends the driving signal of each wheel, then sends the lock signal of the right front wheel to the ABS control unit. There should be kickback.

Mode 6:

Not used on this model.

Inspection points:

1. The ABS indicator light comes ON.
 - Check the Diagnostic Trouble Code and go to the troubleshooting, see page 19-55.
2. There is no or little kickback in modes 2 through 5 and the ABS indicator light does not come ON.
 - Air in the high pressure line.
 - Restricted high pressure line.
 - Faulty modulator unit.



Wheel Sensor Signal Confirmation

NOTE: Use the ALB checker (mode "0") to confirm proper wheel sensor operation.

1. Disconnect the ABS inspection connector (6P) from the connector cover located on the cross-member under the passenger's seat and connect the ABS inspection connector (6P) to the ALB checker.

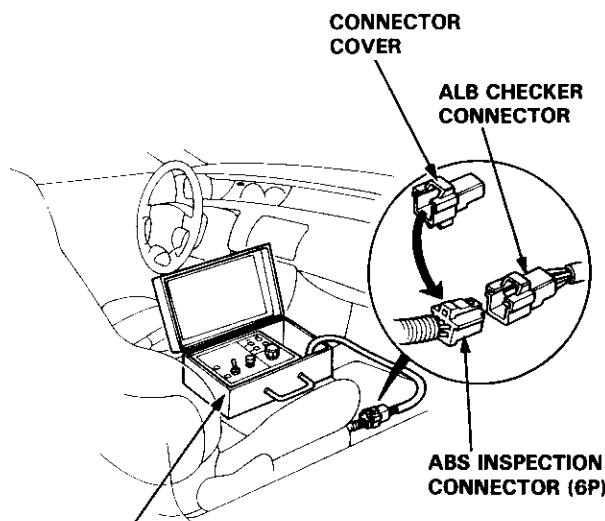

ALB CHECKER
07HAJ-SG0010B

See page 19-32 for other applicable checkers.

2. Raise the car so that all four wheels are off the ground and support on safety stands.
3. Turn the ignition switch ON.
4. Turn the Mode Selector switch to "0".

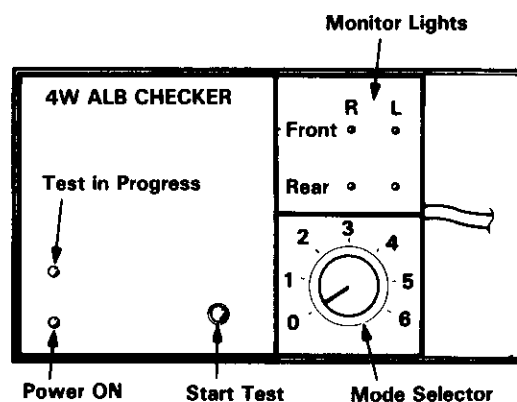

5. With the transmission in neutral, rotate each wheel briskly (one revolution per second) by hand, and confirm that its respective monitor light on the checker blinks as the wheel rotates.

NOTE:

- Rotating a wheel too slowly will produce only a weak blink of its monitor light that may be difficult to see.
- In bright sunlight, the monitor light may be difficult to see. Perform tests in a shaded area.
- In some instances, it may not be possible to spin the front wheels fast enough to get a monitor indication. If necessary, start the engine and slowly accelerate and decelerate the front wheels. The monitor lights should blink, indicating a good wheel sensor signal.

If any monitor light fails to blink, check the suspected sensor, its air gap and its wiring/connectors.

Troubleshooting

Anti-lock Brake System (ABS) Indicator Light

Temporary Driving Conditions:

1. The ABS indicator light comes on and the ABS control unit memorizes the diagnostic trouble code (DTC) under certain conditions.

NOTE: The DTCs are explained on page 19-56.

- The tire(s) adhesion is lost due to excessive cornering speed.
DTC: 5, 5-4, 5-8.
- The vehicle loses traction when starting from a stuck condition on a muddy, snowy, or sandy road.
DTC: 4-1, 4-2, 4-4, 4-8.
- When the parking brake is applied for more than 30 seconds while the vehicle is being driven.
DTC: 2-1.
- The vehicle is driven on an extremely rough road.

The ABS is OK, if the ABS indicator light goes off after the engine is restarted.

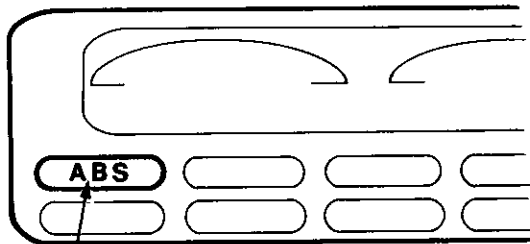

ABS INDICATOR LIGHT

2. If you receive a customer's report that the ABS indicator light sometimes comes on, check the system using the ALB checker to confirm whether there is any trouble in the system.
See page 19-51.
3. The ABS indicator light will come on and the ABS control unit will memorize a DTC when there is insufficient battery voltage to the ABS control unit. An example would be when the battery is so weak that the car must be jump-started. After the battery is sufficiently recharged, the ABS indicator light will work normally after the engine is stopped and restarted.

However, after recharging the battery, the DTC must be cleared from the ABS control unit's memory by disconnecting the ABS B2 (15 A) fuse in the under-hood fuse/relay box for at least three seconds.

ABS Indicator Light Circuit:

CAUTION: Use only the digital multimeter to check the system.

1. The ABS indicator light does not go on when the ignition switch is turned on.

Check the following items. If they are OK, check the ABS control unit connectors. If not loose or disconnected, substitute a known-good ABS control unit and recheck:

- Blown ABS indicator light bulb.
- Open circuit in YEL wire between the No. 13 METER (10 A) fuse in the under-dash fuse/relay box and gauge assembly.
- Open circuit in BLU/RED wire between the gauge assembly and ABS control unit.
- Poor ground connection between the ABS control unit and the body.

2. The ABS indicator light remains ON after the engine is started, however the ABS indicator light does not blink any DTC. Check the following items:

- Loose or poor connection of the wire harness at the ABS control unit.
- Faulty ABS B2 (15 A) fuse in the under-hood fuse/relay box.
- Open circuit in WHT wire between the ABS B2 (15 A) fuse in the under-hood fuse/relay box and ABS control unit.
- Open circuit in BLK/YEL wire between the No. 9 R/C MIRROR (15 A) fuse in the under-dash fuse/relay box and ABS control unit.
- Short circuit in BLU/RED wire between gauge assembly and ABS control unit.
- Open circuit in WHT/BLU wire between alternator and ABS control unit.

If the problem is not found, substitute a known-good ABS control unit and recheck whether the ABS indicator light remains ON.



Diagnostic Trouble Code (DTC):

1. Disconnect the service check connector from the connector cover located behind the front of the center console. Connect the two terminals of the service check connector with a jumper wire.
 2. Turn the ignition switch on, but do not start the engine.
 3. Record the blinking frequency of the ABS indicator light.
- The blinking frequency indicates the diagnostic trouble code (DTC).

CAUTION: Before starting the engine, disconnect the jumper wire from the service check connector, or else the Malfunction Indicator Lamp (MIL) will stay on with the engine running.

DTC indication pattern

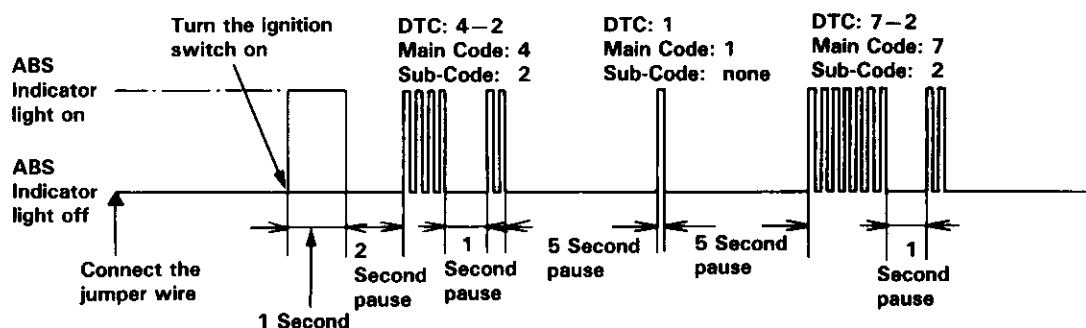

NOTE:

- The ABS control unit can indicate three DTCs (one, two or three problems).
- If the ABS indicator light does not light, see Troubleshooting of ABS Indicator Light Circuit page 19-54.
- If you miscount the blinking frequency, turn the ignition switch off then on to cycle the ABS indicator light again.
- After the repair is completed, disconnect the ABS B2 (15 A) fuse in the under-hood fuse/relay box for at least three seconds to erase the ABS control unit's memory. Then turn the ignition key on again and recheck.
- The memory is erased if the connector is disconnected from the ABS control unit or the ABS control unit is removed from the body.
- After recording the DTC (if applicable), refer to the Symptom-to-System Chart.

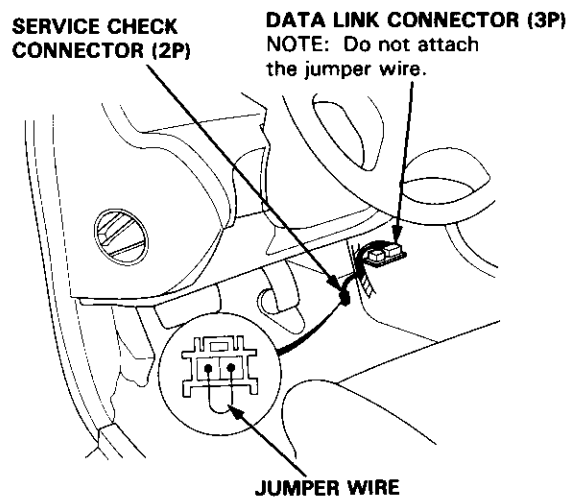
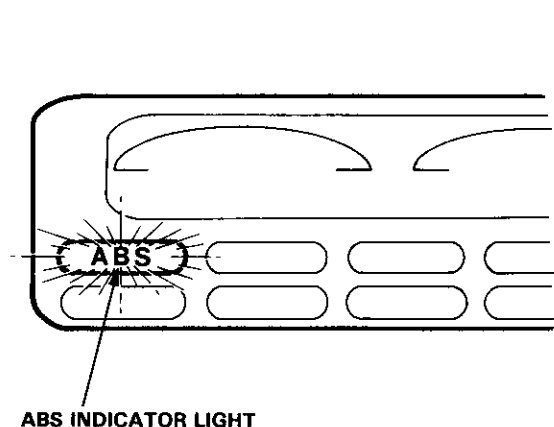

Troubleshooting

Symptom-to-System Chart

DIAGNOSTIC TROUBLE CODE (DTC)		PROBLEMATIC COMPONENT/ SYSTEM	AFFECTED				PAGE	OTHER COMPONENT	PAGE
MAIN CODE	SUB-CODE		FRONT RIGHT	FRONT LEFT	REAR RIGHT	REAR LEFT			
1	-	ABS pump motor over-run	-	-	-	-	19-57	Solenoid ABS pump motor Pressure switch	
	2	ABS pump motor circuit problem	-	-	-	-	19-59	ABS motor relay ABS unit fuse ABS motor fuse	19-87
	3	High pressure leakage	-	-	-	-	19-62	Solenoid(s)	19-84
	4	Pressure switch	-	-	-	-	19-63		
	8	Accumulator gas leakage	-	-	-	-	19-64		
2	1	Parking brake switch-related problem	-	-	-	-	19-64	Brake fluid level switch, Brake system light	
3	1	Pulser(s)	○				19-88	Wheel sensor installation	
	2			○					
	4				○	○			
4	1	Wheel sensor	○				19-65		
	2			○					
	4				○				
	8					○			
5	-	Wheel sensor(s)			○	○	19-67	Modulator Rear brake drag	
	4				○				
	8					○			
6	-	Fail-safe relay		○		○	19-69		19-87 (Function Test)
	1			○					
	4					○			
7	1	Solenoid related problem	○				19-75	ABS B1 fuse Front fail-safe relay	
	2			○			19-78	Rear fail-safe relay	
	4				○	○			



Flowcharts

Diagnostic Trouble Code (DTC) 1: ABS Pump Motor Over-run (20 seconds)

CAUTION: Use only the digital multimeter to check the system.

Pre-test step:

- Check for fluid leaks from the functional parts and replace the faulty parts if there is a leak.

Functional parts:

- Modulator unit
- ABS Pump assembly
- High pressure hose/pipe

– With engine running, ABS indicator light is ON.
 – With service check connector jumped (see page 19-55), DTC 1 is indicated.

Bleed high pressure fluid from the maintenance bleeder with the Bleeder T-wrench (see page 19-81).

Remove the ABS pump motor relay.

Connect the No. 29 and 30 terminals using a jumper wire for about eight seconds.

Does the ABS pump motor run with an increasingly loud, raspy sound?

NO
 Pump runs with a constant soft sound:
 Bleed air from anti-lock brake system using the procedure on page 19-86 and check the pump sound again.

YES
 Check the accumulator fluid quantity by bleeding the high pressure line with the Bleeder T-wrench.

Is there 40–70 cc?

NO (To page 19-58)

YES
 (To page 19-58)

View from under-hood fuse/relay box terminal side.

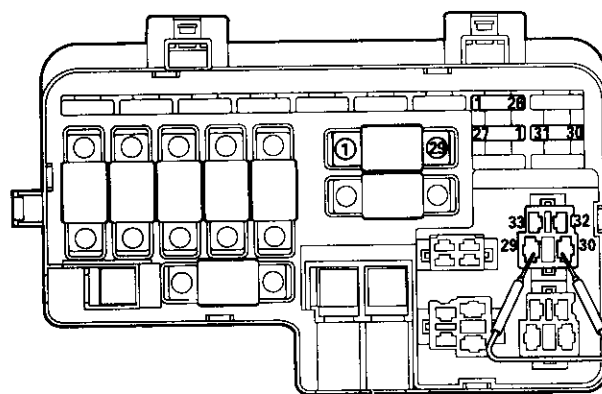

UNDER-HOOD FUSE/RELAY BOX

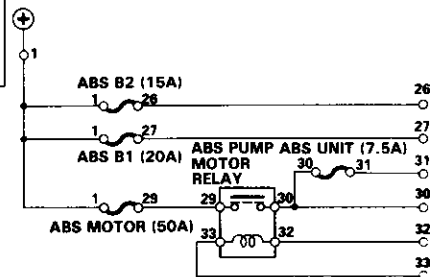

UNDER-HOOD FUSE/RELAY BOX CIRCUIT DIAGRAM

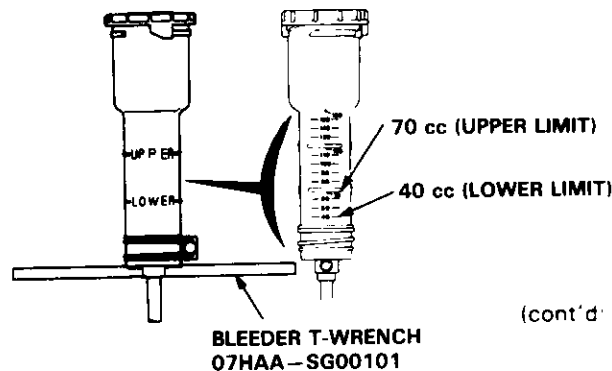

BLEEDER T-WRENCH 07HAA-SG0010

(cont'd)

Troubleshooting

Flowcharts (cont'd)

(From page 19-57)

(From page 19-57)

Connect the No. 29 and No. 30 terminals using a jumper wire for about 10 seconds.

Check if there is any change in the fluid level in the reservoir tank.

Is there any change? NO

Faulty ABS pump motor (Relief valve is defective and open).
Replace the ABS pump assembly.

YES

Faulty solenoid (leakage).
Replace the modulator unit.

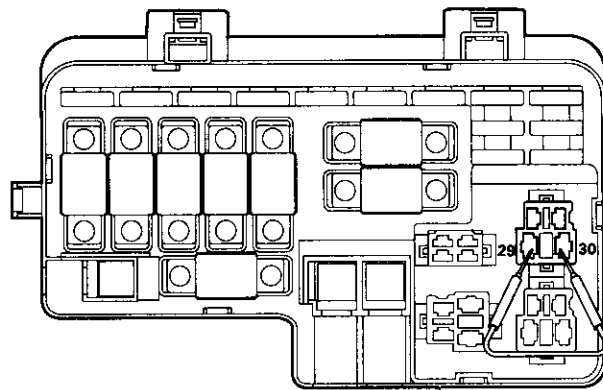

UNDER-HOOD FUSE/RELAY BOX

SWITCH-SIDE CONNECTOR

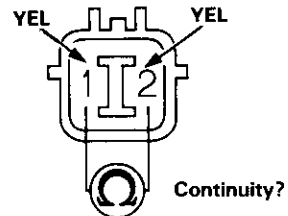

View from terminal side.

Connect the No. 29 and No. 30 terminals using a jumper wire for about 10 seconds.

Disconnect the pressure switch 2P connector and check the continuity between the No. 1 (YEL) and No. 2 (YEL) terminals.

Is there continuity? NO

Replace the pressure switch.

YES

The vehicle is OK at this time.

Diagnostic Trouble Code (DTC) 1-2: ABS Pump Motor Circuit Problem

CAUTION: Use only the digital multimeter to check the system.

NOTE: If a malfunction is detected, this code appears and the fail-safe function is activated. The ABS indicator light comes ON after restarting the engine until the DTC is erased (by disconnecting the ABS B2 (15 A) fuse in the under-hood fuse/relay box for three seconds).

Pre-test steps:

- Check ABS MOTOR (50 A) fuse in the under-hood fuse/relay box.
- Check ABS UNIT (7.5 A) fuse in the under-hood fuse/relay box.
- Check for loose under-hood fuse/relay box connectors.

– With engine running, ABS indicator light is ON.
 – With service check connector jumped (see page 19-55), DTC 1-2 is indicated.

Check the ABS pump motor relay (see page 19-87).

Does it work properly? **NO** → Replace the ABS pump motor relay.

YES
 Connect the No. 29 and No. 30 terminals using a jumper wire.

Does the ABS pump motor run? **NO** → (To page 19-61)

YES
 Disconnect the jumper wire.

Remove the ABS UNIT (7.5 A) fuse in the under-hood fuse/relay box.

Turn the ignition switch ON.

(To page 19-60)

View from under-hood fuse/relay box terminal side.

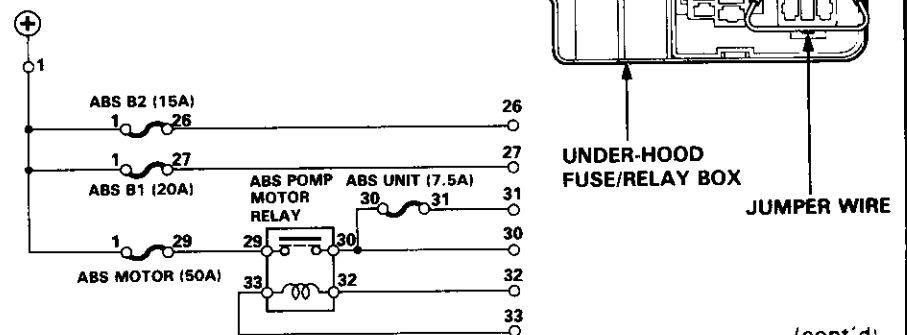
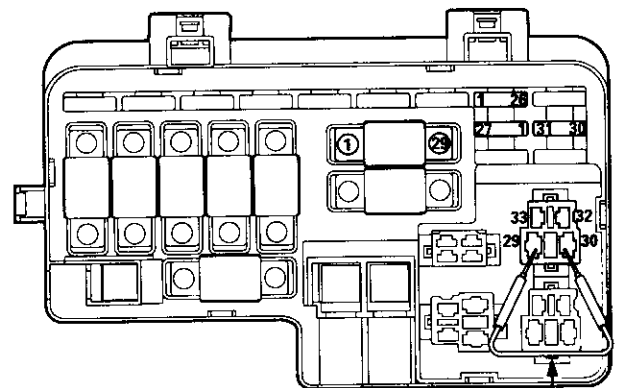

UNDER-HOOD FUSE/RELAY BOX CIRCUIT DIAGRAM

(cont'd)

Troubleshooting

Flowcharts (cont'd)

(From page 19-59)

Check for voltage between the under-hood fuse/relay box ABS UNIT fuse No. 31 terminal and body ground.

Is there battery voltage?

NO

Repair open in WHT/BLK wire between the ABS UNIT (7.5 A) fuse in the under-hood fuse/relay box and ABS control unit.

YES

Reinstall the fuse in the under-hood fuse/relay box.

Disconnect the 2P connector from the ABS pump motor.

Check for voltage between the ABS pump motor relay No. 30 terminal and body ground.

Is there battery voltage?

NO

Replace the under-hood fuse/relay box.

YES

Check for voltage between the No. 32 terminal and body ground.

Is there battery voltage?

NO

Repair open in BLK/YEL wire between the No. 9 R/C MIRROR (15 A) fuse in the under-dash fuse/relay box and ABS pump motor relay.

YES

Reinstall the ABS pump motor relay.

Disconnect the 18P (4WS: 20P) connector from the ABS control unit.

Check for voltage between the ABS control unit connector No. 18 (4WS: No. 21) (YEL/RED) terminal and body ground.

Is there battery voltage?

NO

Repair open in YEL/RED wire between the ABS pump motor relay and ABS control unit.

YES

Check for loose ABS control unit connectors. If necessary, substitute a known-good ABS control unit and recheck.

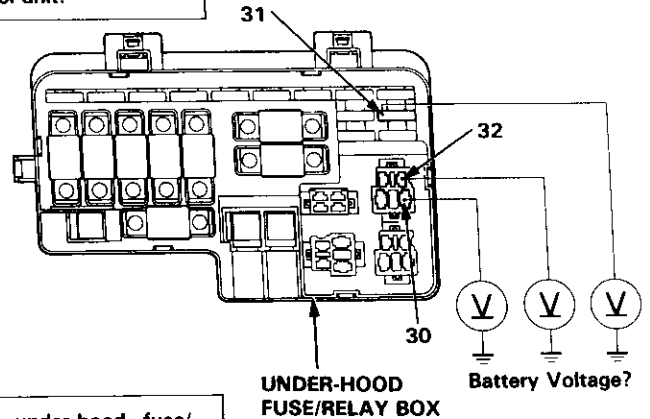

18P CONNECTOR (2WS)

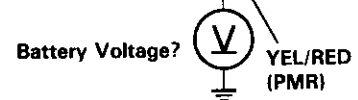
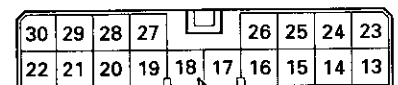

View from ABS control unit terminal side.

20P CONNECTOR (4WS)

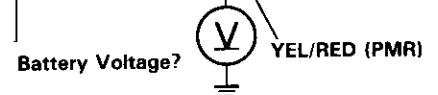
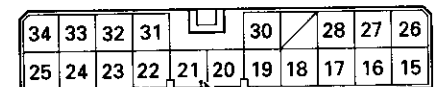

View from ABS control unit terminal side.

(From page 19-59)

Check for voltage between the No. 29 terminal and body ground.

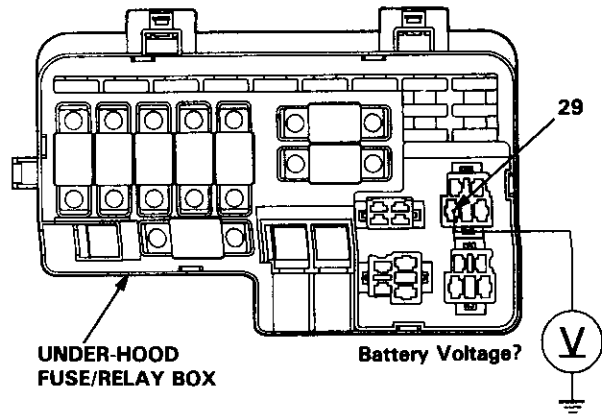

Is there battery voltage?

NO

Replace the under-hood fuse/relay box.

YES

Disconnect the 2P connector from the ABS pump motor.

Check for voltage between the No. 1 (WHT/BLU) terminal and body ground.

HARNESS-SIDE CONNECTOR
BLK (GROUND) WHT/BLU (MOTOR RELAY)

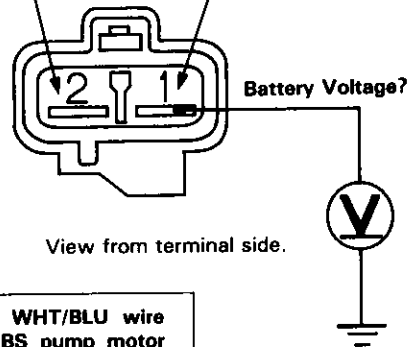

Is there battery voltage?

NO

Repair open in WHT/BLU wire between the ABS pump motor relay and ABS pump motor.

YES

Check for voltage between the No. 1 (WHT/BLU) terminal and No. 2 (BLK) terminal.

HARNESS-SIDE CONNECTOR
BLK (GROUND) WHT/BLU (MOTOR RELAY)

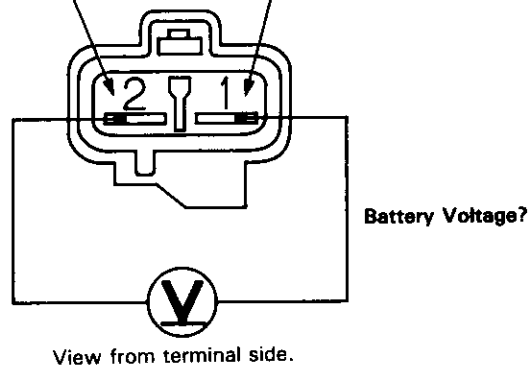

Is there battery voltage?

NO

Repair open in BLK wire between the ABS pump motor and ground or poor ground (G403).

YES

Faulty ABS pump motor. Replace the ABS pump assembly.

(cont'd)

Troubleshooting

Flowcharts (cont'd)

Diagnostic Trouble Code (DTC) 1-3: High Pressure Leakage

CAUTION: Use only the digital multimeter to check the system.

Pre-test steps:

- Check reservoir fluid level, and if necessary, fill to the MAX level line.
- Check for fluid leaks from the functional parts and replace the faulty parts if there is a leak.

Functional parts:

- Modulator unit
- ABS Pump assembly
- High pressure hose/pipe

- With engine running, ABS indicator light is ON.
- With service check connector jumped (see page 19-55), DTC 1-3 is indicated.

Bleed high pressure fluid from the maintenance bleeder with the Bleeder T-wrench (see page 19-81).

Remove the ABS pump motor relay.

Connect the No. 29 and No. 30 terminals using a jumper wire for about 10 seconds.

Disconnect the 2P connector from the pressure switch.

After 30 minutes, check for continuity between the No.1 (YEL) and No.2 (YEL) terminals on the switch side of connector.

Is there continuity?

YES

The vehicle is OK at this time.

NO

Faulty solenoid (leakage).
Replace the modulator unit.

View from under-hood fuse/relay box terminal side.

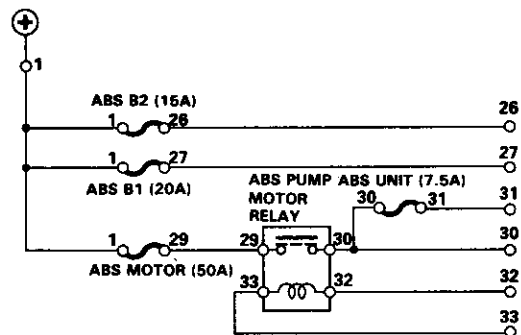
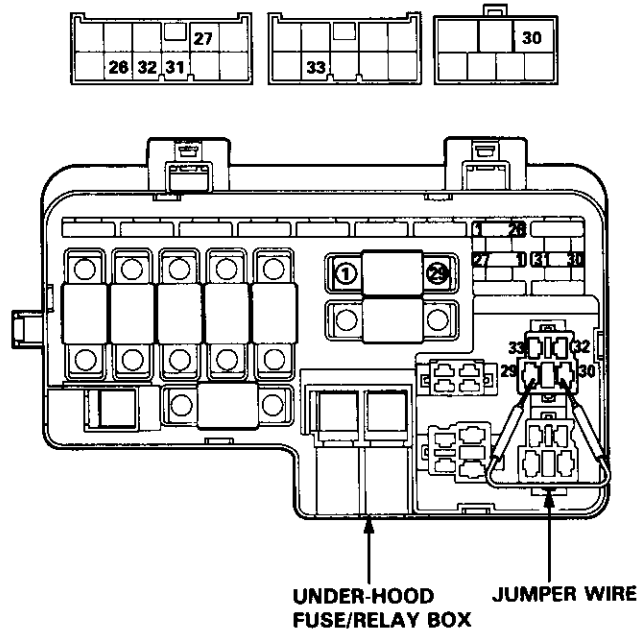

UNDER-HOOD FUSE/RELAY BOX CIRCUIT DIAGRAM

SWITCH SIDE CONNECTOR

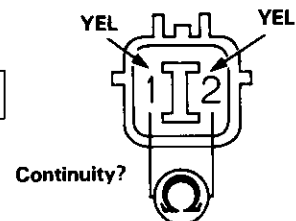

View from terminal side.



Diagnostic Trouble Code (DTC) 1-4: Pressure Switch Circuit

CAUTION: Use only the digital multimeter to check the system.

- With engine running, ABS indicator light is ON.
- With service check connector jumped (see page 19-55), DTC 1-4 is indicated.

Bleed high pressure fluid from the maintenance bleeder with the Bleeder T-wrench (see page 19-81).

Disconnect the 2P connector from the pressure switch.

Check the continuity of pressure switch between the No.1 (YEL) and No.2 (YEL) terminals.

Is there continuity?

YES
Replace the pressure switch (closed).

NO

Check for continuity between the No. 1 (YEL) terminal and body ground on the harness side connector.

Is there continuity?

YES
Repair short in YEL wire between the ABS control unit and pressure switch.

NO

Check for loose ABS control unit connectors. If necessary, substitute a known-good ABS control unit and recheck.

SWITCH-SIDE CONNECTOR

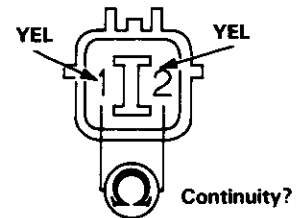

View from terminal side.

HARNESS-SIDE CONNECTOR

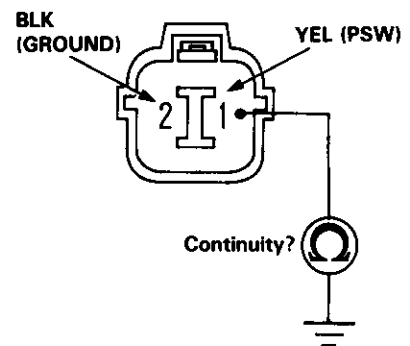

View from terminal side.

(cont'd)

Troubleshooting

Flowcharts (cont'd)

Diagnostic Trouble Code (DTC) 1-8: Accumulator Gas Leakage

Check the following items:

- The relief plug is loose.
- The relief plug O-ring is out of place.
- Bleed the high pressure line with the Bleeder T-wrench. Operate the ABS pump motor for 10 seconds and bleed the high pressure line again with the Bleeder T-wrench. If no fluid or more than 70 cc of fluid come out, replace the ABS pump assembly.

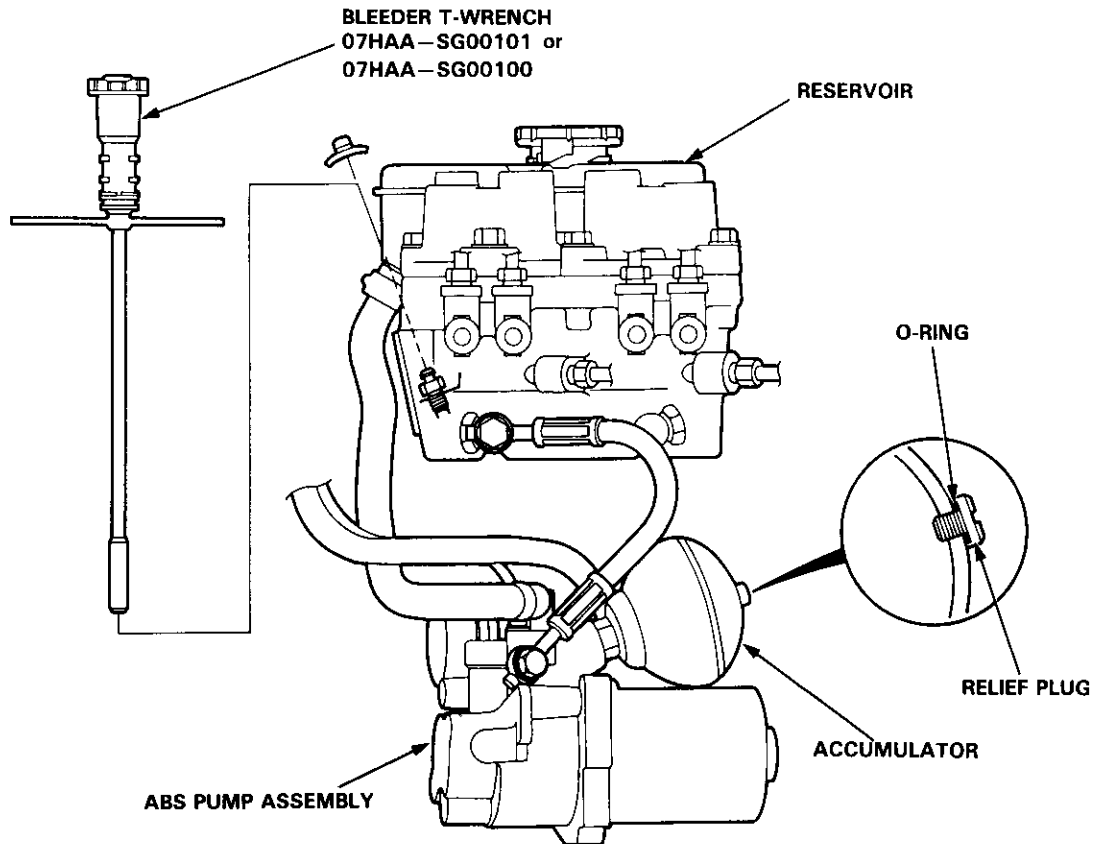

Diagnostic Trouble Code (DTC) 2-1: Parking Brake Switch Related Problem

If the parking brake has been released, the following items are possible causes. If they are OK, check the ABS control unit connectors for good connection. If not loose or disconnected, substitute a known-good ABS control unit and recheck.

NOTE: Before troubleshooting DTC 2-1, remove the ABS B2 (15 A) fuse in the under-hood fuse/relay box for three seconds to clear the ABS control unit's memory, then test drive the car.

If the ABS indicator light stays off, the probability is that the car was driven with the parking brake applied.

- The parking brake is applied for more than 30 seconds while driving.
- The brake fluid level in the master cylinder is too low.
- GRN/RED wire is shorted between the brake system light and parking brake switch.
- GRN/RED wire is shorted between the brake system light and brake fluid level switch.
- The brake system light is blown.
- GRN/RED wire has an open between the brake system light and the ABS control unit.



Diagnostic Trouble Code (DTC) 4-1 to 4-8: Wheel Sensor

CAUTION: Use only the digital multimeter to check the system.

NOTE: If a malfunction is detected, this code appears and the fail-safe function is activated. The ABS indicator light may come ON after restarting the engine until the DTC is erased (by disconnecting the ABS B2 (15 A) fuse in the under-hood fuse/relay box for three seconds).

- With engine running, ABS indicator light is ON.
- With service check connector jumped (see page 19-55), DTCs 4-1, 4-2, 4-4 and/or 4-8 are indicated.

Disconnect the 18P (4WS: 20P) connector from the ABS control unit.

- Check the resistance of each sensor between the positive and negative:
- GRN/BLK: Front Right Positive
GRN: Front Right Negative
 - GRN/BLU: Front Left Positive
BRN: Front Left Negative
 - GRN/YEL: Rear Right Positive
BLU/YEL: Rear Right Negative
 - LT BLU: Rear Left Positive
GRY: Rear Left Negative

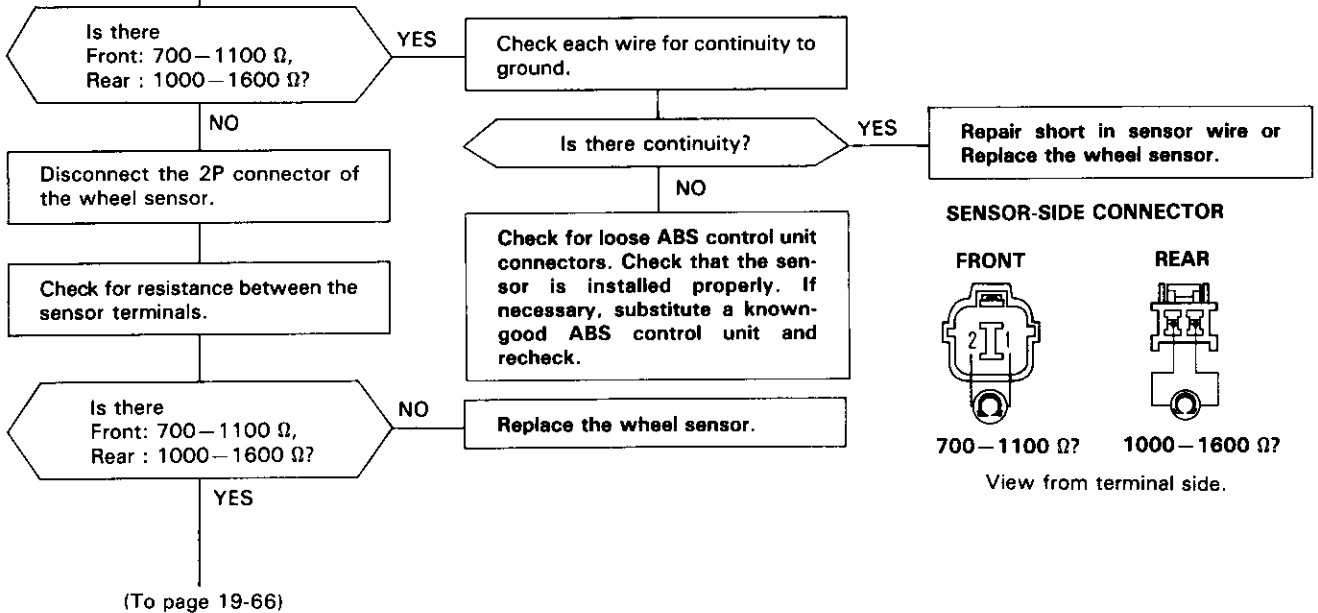
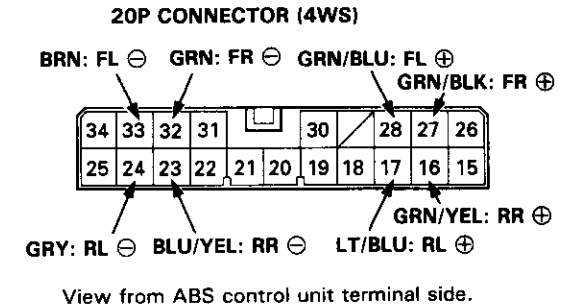
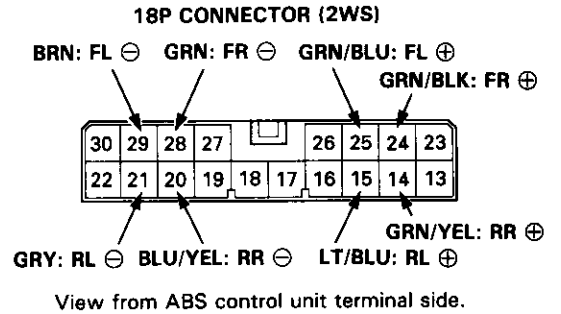

(cont'd)

Troubleshooting

Flowchart (cont'd)

(From page 19-65)

Reconnect the 18P (4WS: 20P) connector to the ABS control unit.

Check each wire for continuity between the wheel sensor harness-side terminals and body ground.

Is there continuity?

NO

Repair open in wire harness.

YES

Check for loose wheel sensor connectors. If necessary, substitute a known-good ABS control unit and recheck.

Positive: $3.3\text{ k}\Omega \pm 15\%$ is OK.
Negative: Less than $1\ \Omega$ is OK.

HARNESS-SIDE CONNECTOR

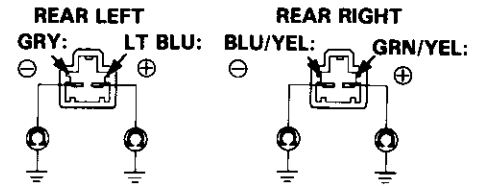
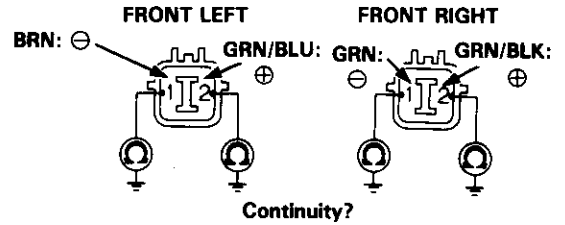

View from terminal side.



Diagnostic Trouble Code (DTC) 5 to 5-8: Wheel Sensor(s)

CAUTION: Use only the digital multimeter to check the system.

NOTE: If a malfunction is detected, this code appears and the fail-safe function is activated. The ABS indicator light may come ON after restarting the engine until the DTC is erased (by disconnecting the ABS B2 (15 A) fuse in the under-hood fuse/relay box for three seconds.)

- With engine running, ABS indicator light is ON.
- With service check connector jumped (see page 19-55), DTCs 5, 5-4 or 5-8 is indicated.

Disconnect the 18P (4WS: 20P) connector from the ABS control unit.

Check the resistance of each sensor between the positive and negative:

- GRN/YEL: Rear Right Positive
- BLU/YEL: Rear Right Negative
- LT BLU: Rear Left Positive
- GRY: Rear Left Negative

Is there 1000–1600 Ω?

YES: Check each wire for continuity to ground.

NO

Disconnect the wire harness from wheel sensor.

Check for resistance between the sensor terminals.

Is there 1000–1600 Ω?

YES

(To page 19-68)

NO

Replace the wheel sensor.

Check each wire for continuity to ground.

Is there continuity?

YES

Repair short in sensor wire or Replace the wheel sensor.

NO

Reconnect the 18P (4WS: 20P) connector to the ABS control unit.

Connect the ALB checker to the ABS inspection connector.

Check for ABS function in mode 2 and 3.

Does it work properly?

NO

Replace the modulator unit.

YES

Check for rear brake drag. If OK, substitute a known-good ABS control unit and recheck.

18P CONNECTOR (2WS)



GRY: RL ⊖ LT BLU: RL ⊕
 BLU/YEL: RR ⊖ GRN/YEL: RR ⊕

View from ABS control unit terminal side.

20P CONNECTOR (4WS)

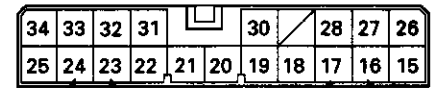

GRY: RL ⊖ LT BLU: RL ⊕
 BLU/YEL: RR ⊖ GRN/YEL: RR ⊕

View from ABS control unit terminal side.

SENSOR-SIDE CONNECTOR REAR

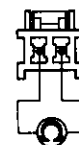

1000–1600 Ω

View from terminal side. (cont'd)

Troubleshooting

Flowcharts (cont'd)

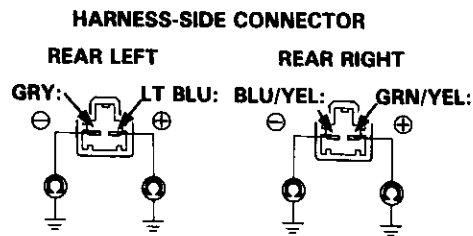
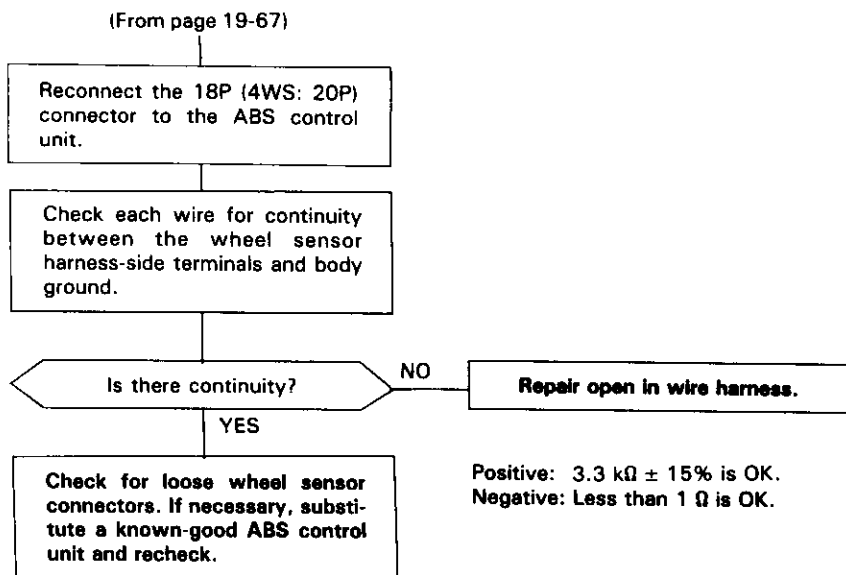

Continuity?
View from terminal side.

Positive: $3.3 \text{ k}\Omega \pm 15\%$ is OK.
Negative: Less than 1Ω is OK.



Diagnostic Trouble Code (DTC) 6-1: Front Fail-Safe Relay Circuit

CAUTION: Use only the digital multimeter to check the system.

Pre-test steps:

- Check ABS B1 (20 A) fuse in the under-hood fuse/relay box.
- Check for loose under-hood fuse/relay box connectors.

– With engine running, ABS indicator light is ON.
 – With service check connector jumped (see page 19-55), DTC 6-1 is indicated.

Remove the front fail-safe relay from under the gauge assembly.

Wire colors of the fail-safe relay connector
 Front: BRN/BLK, BLK/YEL, YEL/GRN, BLK
 Rear: BLU/BLK, BLK/YEL, YEL/GRN, BLK

Check relay function (see page 19-87).

Does it work properly?

NO → **Replace the front fail-safe relay.**

YES

Turn the ignition switch ON.

Check for voltage between the fail-safe relay connector No. 1 (BLK/YEL) terminal and body ground.

Is there battery voltage?

NO → **Repair open in BLK/YEL wire between the No. 9 R/C MIRROR (15 A) fuse in the under-dash fuse/relay box and front fail-safe relay.**

YES

Turn the ignition switch OFF.

Disconnect the 10P connector from the solenoids.

Check for continuity between the fail-safe relay connector No. 2 (BRN/BLK) terminal and body ground.

(To page 19-70)

FAIL-SAFE RELAYS

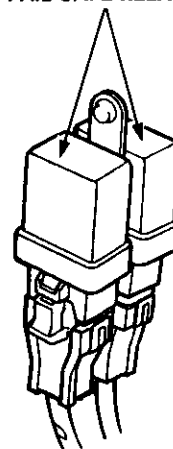

HARNESS-SIDE CONNECTOR

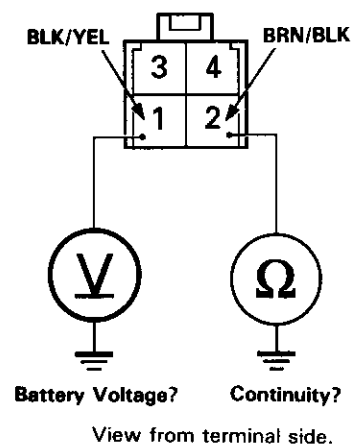

(cont'd)

Troubleshooting

Flowcharts (cont'd)

(From page 19-69)

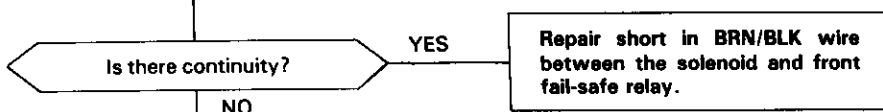

Check each wire for continuity between the solenoid terminals and body ground
 No. 4 (BRN/BLK): Front Right
 No. 6 (BRN/BLU): Front Left

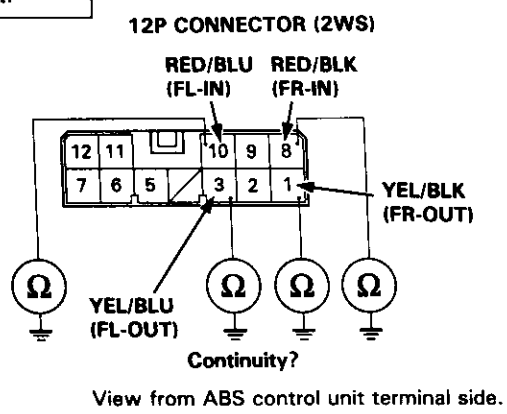
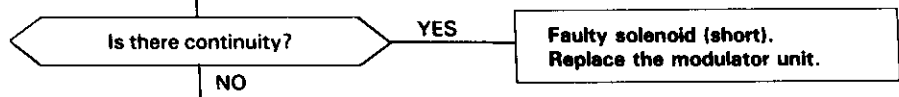
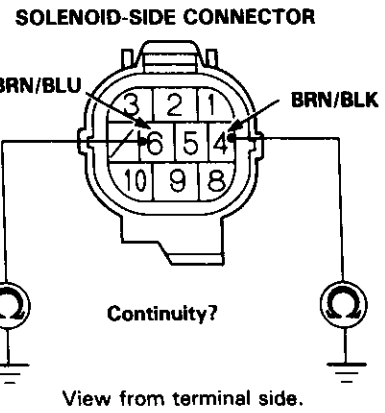

Disconnect the connectors from the ABS control unit.

Check each wire for continuity between the ABS control unit connector and body ground.
 RED/BLK: Front Right Inlet
 YEL/BLK: Front Right Outlet
 RED/BLU: Front Left Inlet
 YEL/BLU: Front Left Outlet

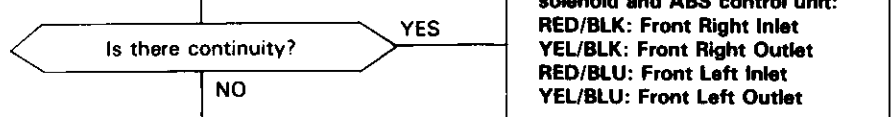
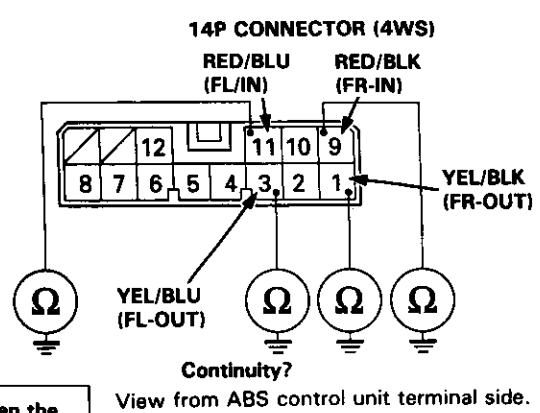

(To page 19-71)



(From page 19-70)

Disconnect the rear fail-safe relay connector.

Check for continuity between the No. 17 (4WS: No. 19) (YEL/GRN) terminal and body ground.

Is there continuity?

YES

Repair short in YEL/GRN wire between the ABS control unit and front fail-safe relay.

NO

Reinstall the front fail-safe relay.

Turn the ignition switch ON.

Check for voltage between the ABS control unit connector No. 17 (4WS: No. 19) (YEL/GRN) terminal and body ground.

Is there battery voltage?

NO

Repair open in YEL/GRN wire between the front fail-safe relay and ABS control unit.

YES

Check for loose ABS control unit connectors. If necessary, substitute a known-good ABS control unit and recheck.

18P CONNECTOR (2WS)

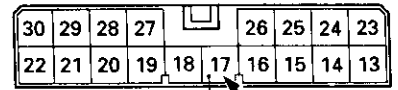

Continuity?



YEL/GRN (FSR)

View from ABS control unit terminal side.

20P CONNECTOR (4WS)

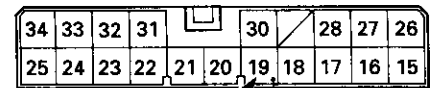

YEL/GRN (FSR)

Continuity?



View from ABS control unit terminal side.

18P CONNECTOR (2WS)

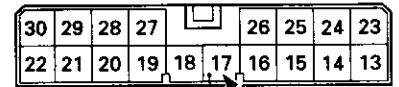

Battery voltage?



YEL/GRN (FSR)

View from ABS control unit terminal side.

20P CONNECTOR (4WS)

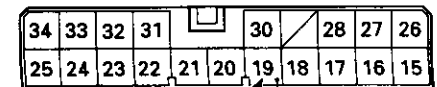

YEL/GRN (FSR)

Battery Voltage?



View from ABS control unit terminal side.

(cont'd)

Troubleshooting

Flowcharts (cont'd)

Diagnostic Trouble Code (DTC) 6-4: Rear Fail-Safe Relay Circuit

CAUTION: Use only digital multimeter to check the system.

- With engine running, ABS indicator light is ON.
- With service check connector jumped (see page 19-55), DTC 6-4 is indicated.

Remove the rear fail-safe relay from under the gauge assembly.

Wire colors of the fail-safe relay connector
 Front: BRN/BLK, BLK/YEL, YEL/GRN, BLK
 Rear: BLU/BLK, BLK/YEL, YEL/GRN, BLK

Check relay function (see page 19-87).

Does it work properly? NO Replace the rear fail-safe relay.

YES
 Turn the ignition switch ON.

Check for voltage between the fail-safe relay connector No. 1 (BLK/YEL) terminal and body ground.

Is there battery voltage? NO Repair open in BLK/YEL wire between the No. 9 R/C MIRROR (15 A) fuse in the under-dash fuse/relay box and front fail-safe relay.

YES
 Turn the ignition switch OFF.

Disconnect the 10P connector from the solenoids.

Check for continuity between the fail-safe relay connector No. 2 (BLU/BLK) terminal and body ground.

Is there continuity? YES Repair short in BLU/BLK wire between the solenoid and rear fail-safe relay.

NO
 (To page 19-73)

FAIL-SAFE RELAYS

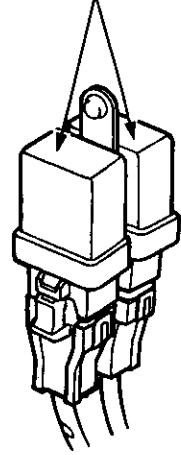

HARNESS-SIDE CONNECTOR

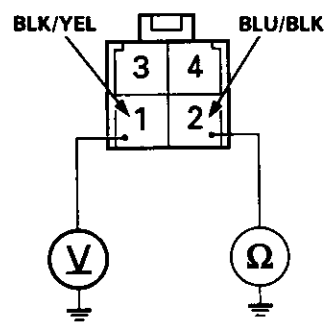

Battery Voltage? Continuity?

View from terminal side.



(From page 19-72)

Check for continuity between the solenoid No. 5 (BRN/WHT) terminal and body ground.

Is there continuity?

YES

Faulty solenoid (short).
Replace the modulator unit.

NO

Disconnect the connectors from the ABS control unit.

Check each wire for continuity between the ABS control unit connector and body ground.
RED/WHT: Rear Inlet
YEL/WHT: Rear Outlet

Is there continuity?

YES

Repair short in wire between the solenoid and ABS control unit:
RED/WHT: Rear Inlet
YEL/WHT: Rear Outlet

NO

(To page 19-74)

SOLENOID-SIDE CONNECTOR

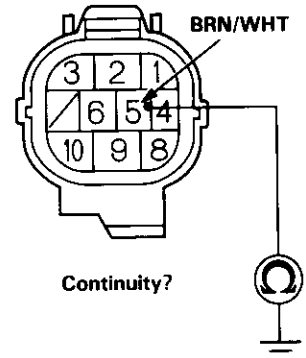

Continuity?

View from terminal side.

12P CONNECTOR (2WS)

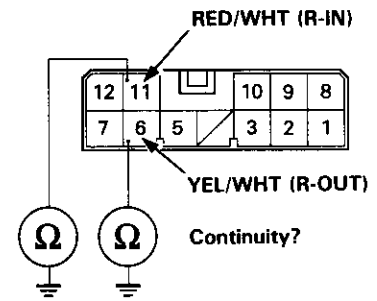

Continuity?

View from ABS control unit terminal side.

14P CONNECTOR (4WS)

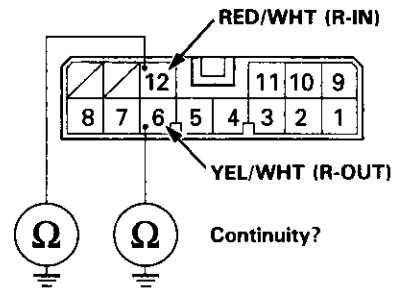

Continuity?

View from ABS control unit terminal side.

(cont'd)

Troubleshooting

Flowcharts (cont'd)

(From page 19-73)

Disconnect the front fail-safe relay connector.

Check for continuity between the No. 17 (4WS: No. 19) (YEL/GRN) terminal and body ground.

Is there continuity?

YES

Repair short in YEL/GRN wire between the ABS control unit and rear fail-safe relay.

NO

Reinstall the rear fail-safe relay.

Turn the ignition switch ON.

Check for voltage between the ABS control unit connector No. 17 (4WS: No. 19) (YEL/GRN) terminal and body ground.

Is there battery voltage?

NO

Repair open in YEL/GRN wire between the rear fail-safe relay and ABS control unit.

YES

Check for loose ABS control unit connectors. If necessary, substitute a known-good ABS control unit and recheck.

18P CONNECTOR (2WS)

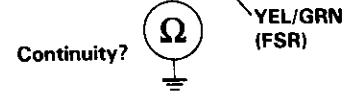
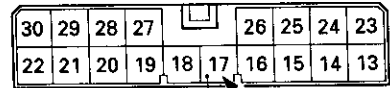

View from ABS control unit terminal side.

20P CONNECTOR (4WS)

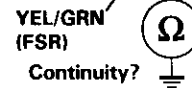
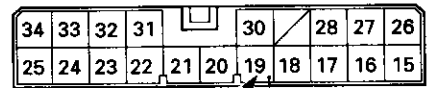

View from ABS control unit terminal side.

18P CONNECTOR (2WS)

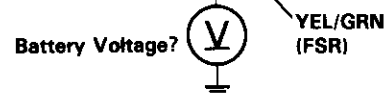
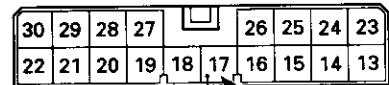

View from ABS control unit terminal side.

20P CONNECTOR (4WS)

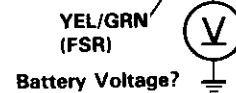
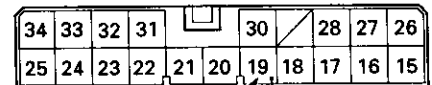

View from ABS control unit terminal side.

Diagnostic Trouble Code (DTC) 7-1 and 7-2: Front Solenoid Related Problem

CAUTION: Use only the digital multimeter to check the system.

Pre-test steps:

- Check ABS B1 (20 A) fuse in the under-hood fuse/relay box.
- Check for loose under-hood fuse/relay box connectors.

— With engine running, ABS indicator light is ON.
 — With service check connector jumped (see page 19-55), DTCs 7-1 and/or 7-2 is indicated.

Disconnect the 10P connector from the solenoids.

Check for resistance between the solenoid terminal:
 No. 1 (RED/BLK) and No. 4 (BRN/BLK): Front Right Inlet
 No. 3 (RED/BLU) and No. 6 (BRN/BLU): Front Left Inlet

Is there 1–3 Ω?

NO
Faulty solenoid
Replace the modulator unit.

YES

Check for resistance between the solenoid terminals:
 No. 8 (YEL/BLK) and No. 4 (BRN/BLK): Front Right Outlet
 No. 10 (YEL/BLU) and No. 6 (BRN/BLU): Front Left Outlet

Is there 1–3 Ω?

NO
Faulty solenoid
Replace the modulator unit.

YES

(To page 19-76)

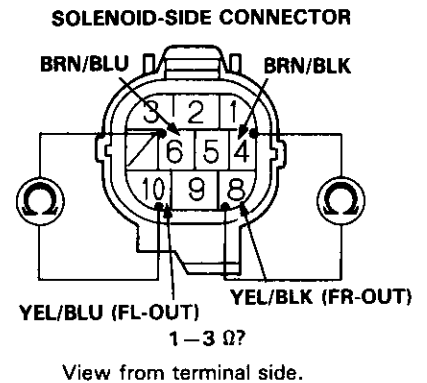
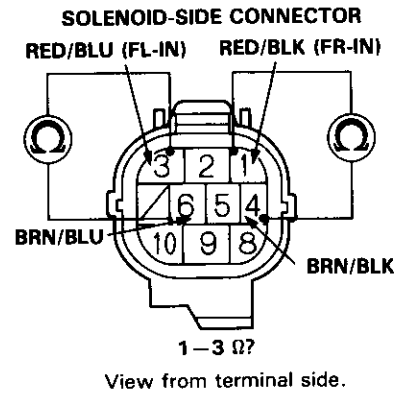

(cont'd)

Troubleshooting

Flowcharts (cont'd)

(From page 19-75)

Disconnect the 12P (4WS: 14P) connector from the ABS control unit.

Check each wire for continuity between the ABS control unit and front solenoid.

RED/BLK: Front Right Inlet
 YEL/BLK: Front Right Outlet
 RED/BLU: Front Left Inlet
 YEL/BLU: Front Left Outlet

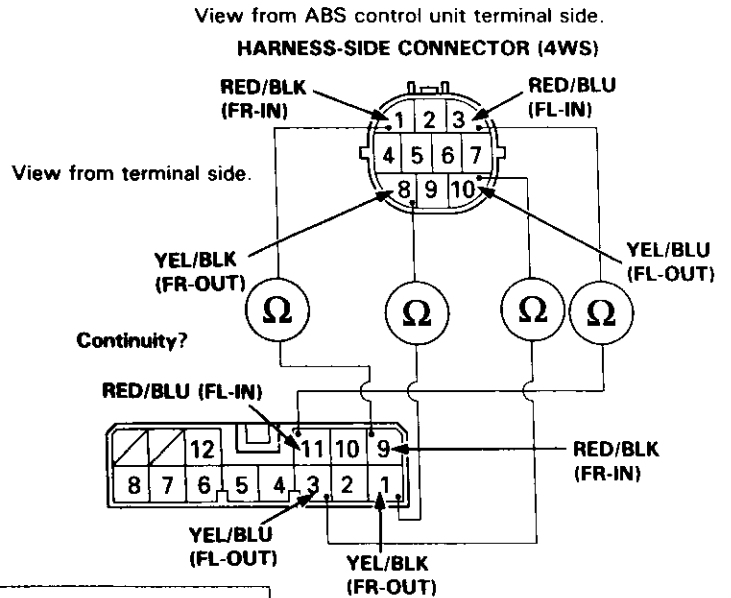
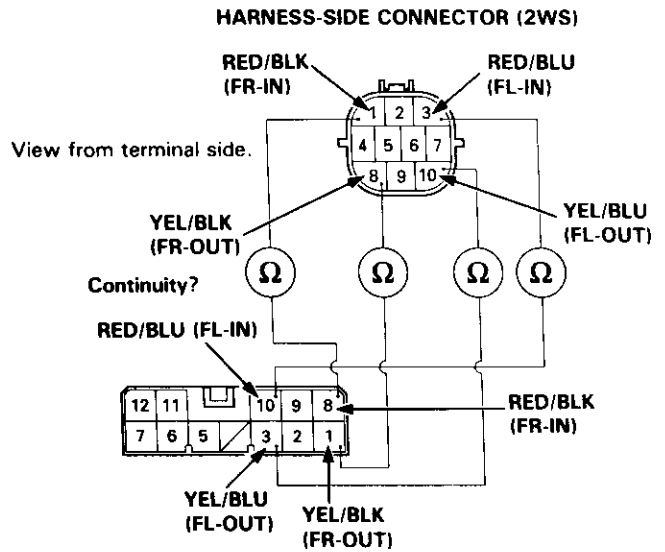

Is there continuity?

NO

Repair open in wire between the solenoid and ABS control unit:

RED/BLK: Front Right Inlet
 YEL/BLK: Front Right Outlet
 RED/BLU: Front Left Inlet
 YEL/BLU: Front Left Outlet

YES

Check each wire for continuity between the ABS control unit and body ground.

RED/BLK: Front Right Inlet
 YEL/BLK: Front Right Outlet
 RED/BLU: Front Left Inlet
 YEL/BLU: Front Left Outlet

12P CONNECTOR (2WS)

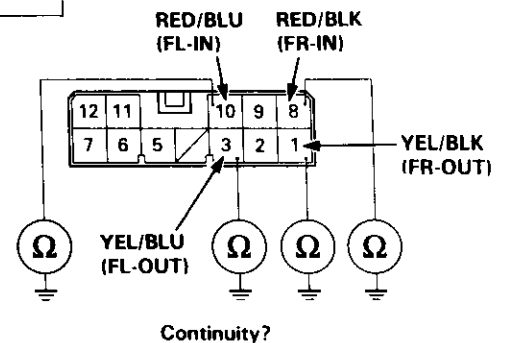

(To page 19-77)

View from ABS control unit terminal side.



(From page 19-76)

14P CONNECTOR (4WS)

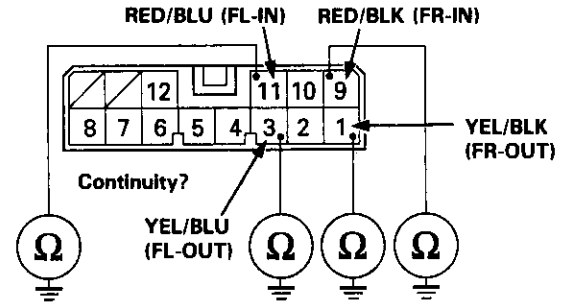

View from ABS control unit terminal side.

View from control unit terminal side.

Is there continuity?

YES

Repair short in wire between the solenoid and ABS control unit:
 RED/BLK: Front Right Inlet
 YEL/BLK: Front Right Outlet
 RED/BLU: Front Left Inlet
 YEL/BLU: Front Left Outlet

NO

Remove the front fail-safe relay from under the gauge assembly.

Wire colors of the fail-safe relay connector
 Front: BRN/BLK, BLK/YEL, YEL/GRN, BLK
 Rear: BLU/BLK, BLK/YEL, YEL/GRN, BLK

Check for relay function (see page 19-87).

Does it work properly?

NO

Replace the front fail-safe relay.

YES

Check for continuity between the fail-safe relay connector No. 4 terminal and body ground.

Is there continuity?

NO

Repair open in BLK wire between the fail-safe relay and ground or poor ground (G401, G402, G404).

YES

Check BRN/BLK wire for continuity between the solenoids and front fail-safe relay.

Is there continuity?

NO

Repair open in BRN/BLK wire between the solenoids and front fail-safe relay.

YES

Check for loose ABS control unit connectors. If necessary, substitute a known-good ABS control unit and recheck.

FAIL-SAFE RELAYS

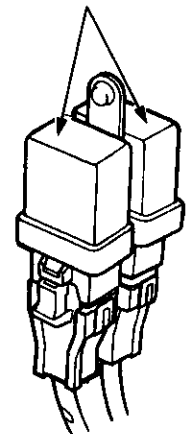

HARNESS-SIDE CONNECTOR

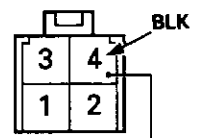

Continuity?



View from terminal side.

HARNESS-SIDE CONNECTOR

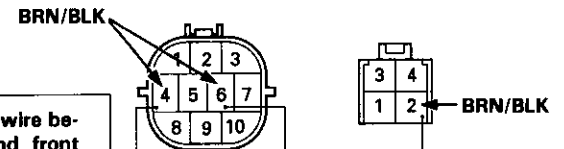

Continuity?

View from terminal side.

(cont'd)

Troubleshooting

Flowcharts (cont'd)

Diagnostic Trouble Code (DTC) 7-4: Rear Solenoid Problem

CAUTION: Use only the digital multimeter to check the system.

- With engine running, ABS indicator light is ON.
- With service check connector jumped (see page 19-55), DTC 7-4 is indicated.

Disconnect the 10P connector from the solenoids.

Check for resistance between the solenoid terminals:
 No. 2 (RED/WHT) and No. 5 (BRN/WHT): Rear Inlet
 No. 9 (YEL/WHT) and No. 5 (BRN/WHT): Rear Outlet

Is there 1-3 Ω ?

NO

Faulty solenoid.
 Replace the modulator unit.

YES

Disconnect the 12P (4WS: 14P) connector from ABS control unit.

Check each wire for continuity between the ABS control unit and rear solenoid:
 RED/WHT: Rear Inlet
 YEL/WHT: Rear Outlet

Is there continuity?

NO

Repair open in wire between the solenoid and ABS control unit:
 RED/WHT: Rear Inlet
 YEL/WHT: Rear Outlet

YES

(To page 19-79)

SOLENOID-SIDE CONNECTOR

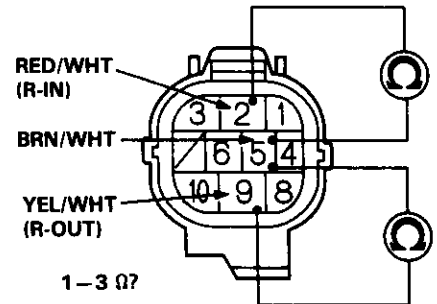

View from terminal side.

HARNESS-SIDE CONNECTOR (2WS)

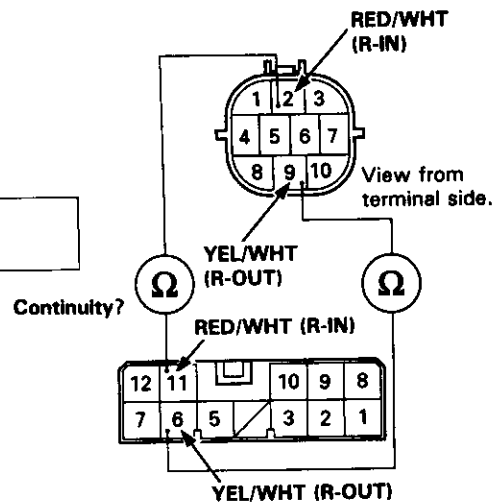

View from ABS control unit terminal side.

HARNESS-SIDE CONNECTOR (4WS)

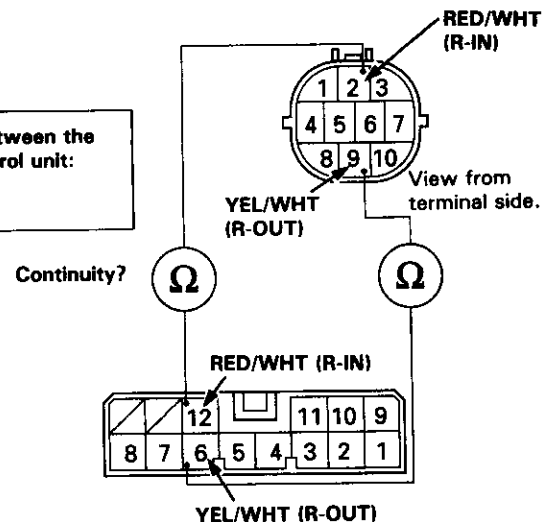

View from ABS control unit terminal side.



(From page 19-78)

Check each wire for continuity between the ABS control unit and body ground:
RED/WHT: Rear Inlet
YEL/WHT: Rear Outlet

12P CONNECTOR (2WS)

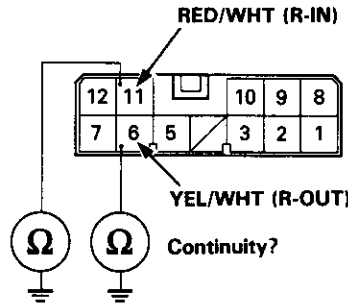

View from ABS control unit terminal side.

14P CONNECTOR (4WS)

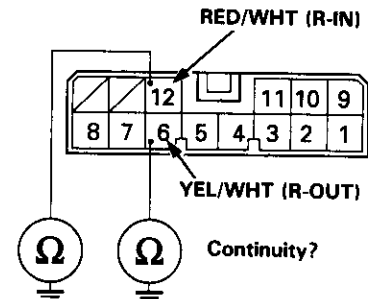

View from ABS control unit terminal side.

Is there continuity?

YES

Repair short in wire between the solenoid and ABS control unit:
RED/WHT: Rear Inlet
YEL/WHT: Rear Outlet

NO

Remove the rear fail-safe relay from under the gauge assembly.

Wire colors of the fail-safe relay connector
Front: BRN/BLK, BLK/YEL, YEL/GRN, BLK
Rear: BLU/BLK, BLK/YEL, YEL/GRN, BLK

Check for relay function (see page 19-87).

Does it work properly?

NO

Replace the rear fail-safe relay.

YES

Check for continuity between the fail-safe relay connector No. 4 (BLK) terminal and body ground.

Is there continuity?

NO

Repair open in BLK wire between the fail-safe relay and ground or poor ground (G401, G402, G404).

YES

Check BLU/BLK wire for continuity between the solenoid and rear fail-safe relay.

Is there continuity?

NO

Repair open in BLU/BLK wire between the solenoid and rear fail-safe relay.

YES

Check for loose ABS control unit connectors. If necessary, substitute a known-good ABS control unit and recheck.

FAIL-SAFE RELAYS

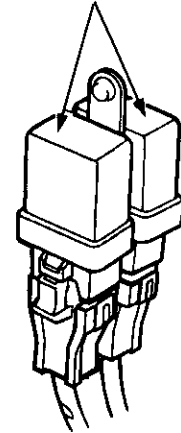

HARNESS-SIDE CONNECTOR

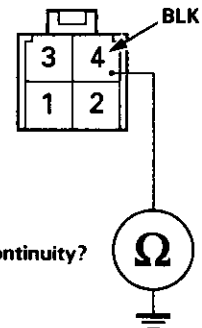

View from terminal side.

HARNESS-SIDE CONNECTOR

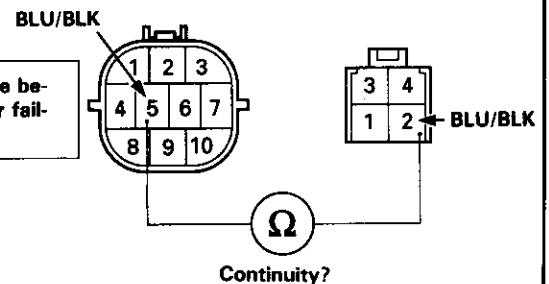

View from terminal side.

Hydraulic System

Index/Hydraulic Connections

CAUTION: Do not spill brake fluid on the car; it may damage the paint; if brake fluid does contact the paint, wash it off immediately with water.

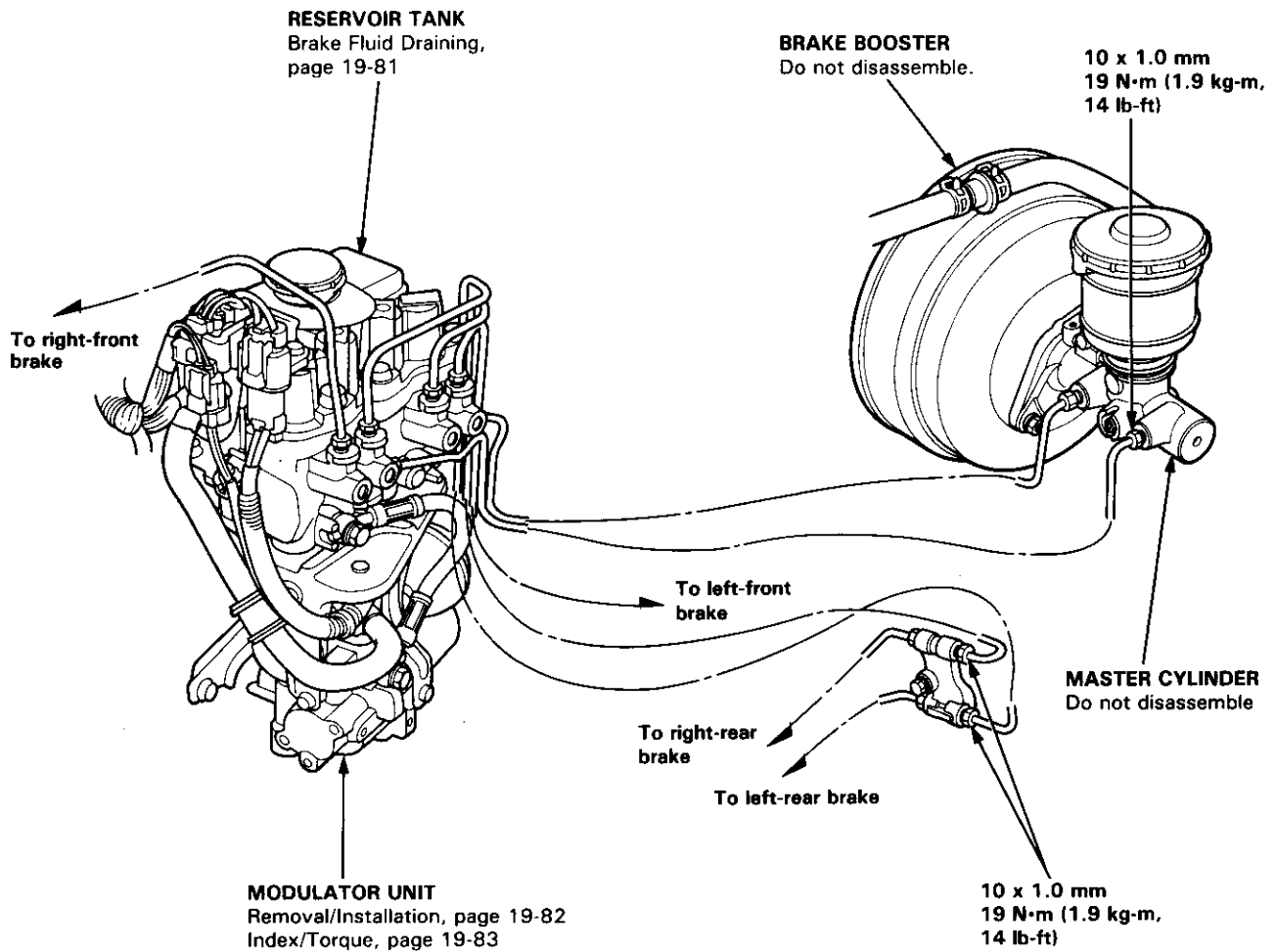



Relieving Accumulator/Line Pressure

▲ WARNING Use the Bleeder T-wrench before disassembling the parts shaded in the illustration.

1. Open the hood.
2. Remove the red cap from the bleeder on the modulator body.
3. Install the special tool on the maintenance bleeder and turn it out slowly 90° to collect high-pressure fluid into the reservoir. Turn the special tool out one complete turn to drain the brake fluid thoroughly.
4. Retighten the maintenance bleeder and discard the fluid.
5. Reinstall the red cap.

Reservoir Brake Fluid Draining

1. Draining brake fluid from modulator tank:
The brake fluid may be sucked out through the top of the modulator tank with a syringe. It may also be drained through the pump joint after disconnecting the pump hose.
2. Draining brake fluid from master cylinder:
Loosen the bleed screw and pump the brake pedal to drain the brake fluid from the master cylinder.

▲ WARNING

- High-pressure fluid will squirt out if the shaded hose and pipe are removed.
- To drain high-pressure brake fluid, follow the procedure on this page.

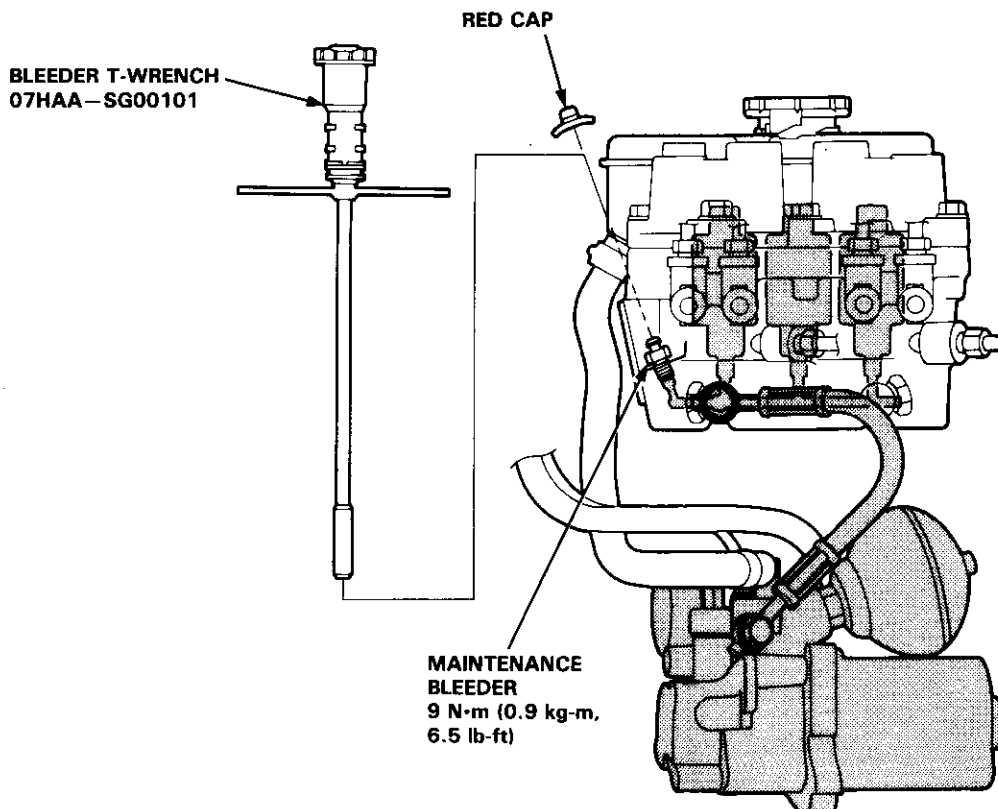

Modulator Unit

Removal/Installation

CAUTION:

- Be careful not to bend or damage the brake pipes when removing the modulator unit.
- Do not spill brake fluid on the car; it may damage the paint; if brake fluid does contact the paint, wash it off immediately with water.
- To prevent spills, cover the hose joints with rags or shop towels.
- Before reassembling, check that all parts are free of dust and other foreign particles.
- Do not mix different brands of brake fluid as they may not be compatible.
- Do not reuse the drained fluid. Use only clean DOT 3 or 4 brake fluid.
- When connecting the brake pipes, make sure that there is no interference between the brake pipes and other parts.

1. Drain the brake fluid from the master cylinder.
2. Relieve the high pressure fluid (see page 19-81) when the high pressure hose is to be disconnected.
3. Remove the intake air duct.
4. Disconnect the solenoid, pump motor and pressure switch connectors.
5. Disconnect the six brake pipes from the modulator unit.
6. Loosen the two lower mounting bolts, and remove the upper mounting bolt and the modulator unit from the frame.
7. Install the modulator unit in the reverse order of removal.
8. After installation, fill and bleed the hydraulic system.

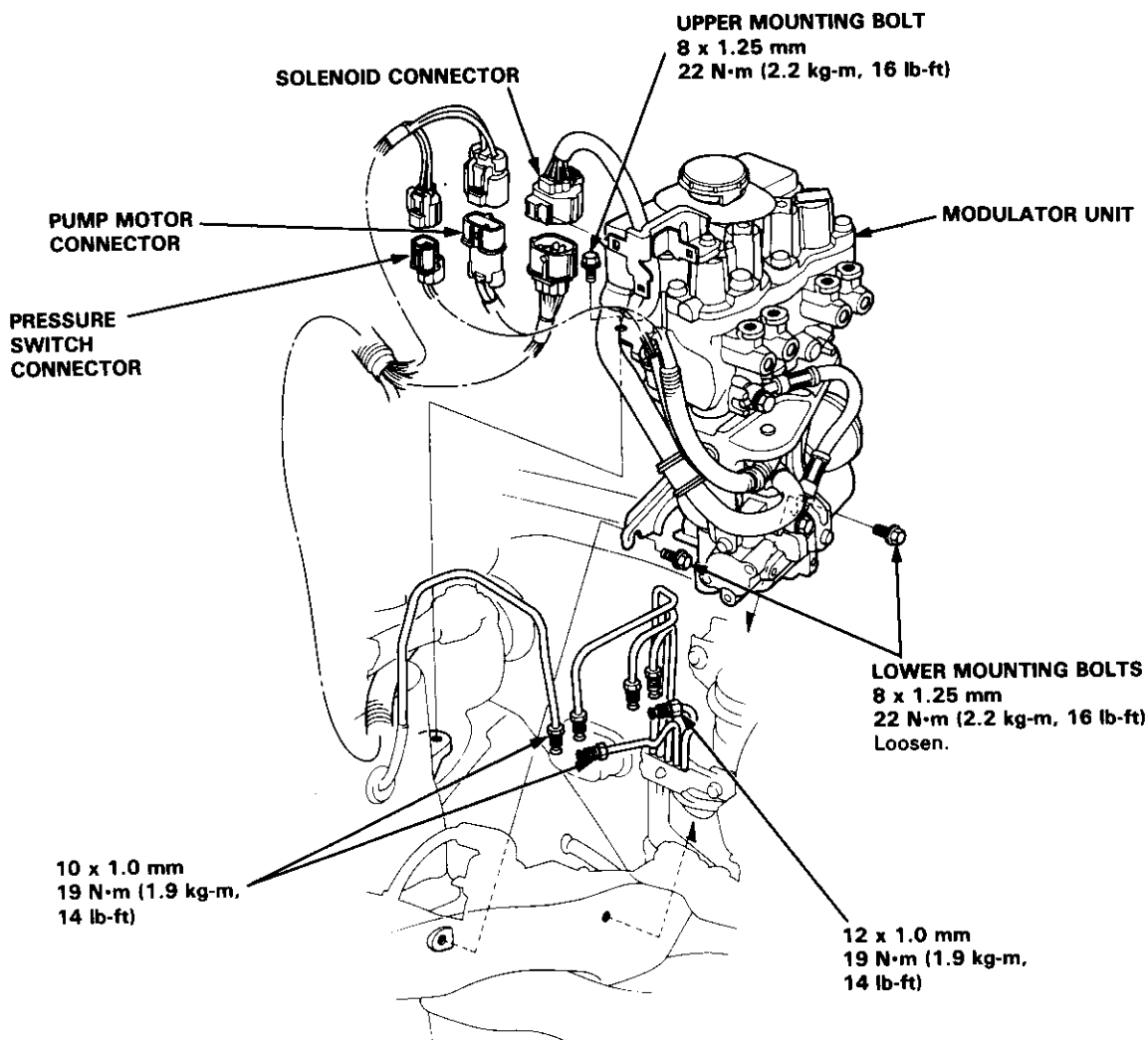



Index/Torque

⚠ WARNING Before removing the modulator-to-pump high-pressure line, be sure to relieve the fluid pressure from the maintenance bleeder (see page 19-81).

CAUTION:

- Do not spill brake fluid on the car; it may damage the paint; if brake fluid does contact the paint, wash it off immediately with water.
- To prevent spills, cover the hose joints with rags or shop towels.
- Before reassembling, check that all parts are free of dust and other foreign particles.
- Do not mix different brands of brake fluid as they may not be compatible.
- Do not reuse the drained fluid. Use only clean DOT 3 or 4 brake fluid.
- Do not disassemble the modulator unit. Replace the modulator unit as an assembly if it is defective.
- Do not disassemble the pump (except pressure switch).

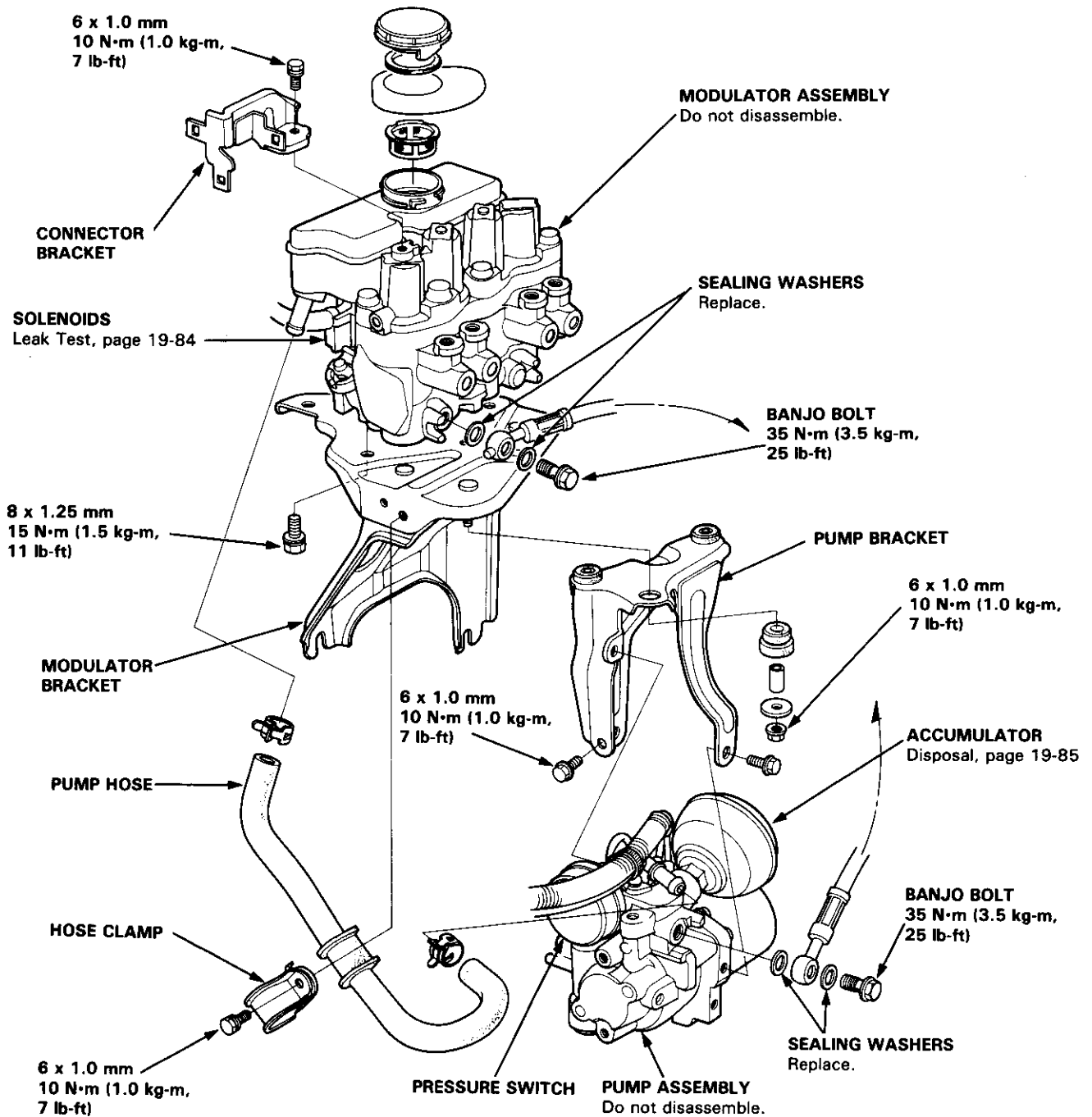

Solenoids

Leak Test

NOTE: If a solenoid leaks excessively, the brake fluid level in the modulator reservoir tank will rise when operating the ABS pump motor. The modulator reservoir may also overflow.

1. Disconnect the pump motor and pressure switch connectors.
2. Connect an ohmmeter between the YEL and YEL terminals of the pressure switch connector.
3. Attach the positive (+) lead of a fully charged 12 V battery to the RED/WHT terminal of the motor connector and negative (-) lead to the GRN terminal, and install a switch between negative lead and GRN terminal as shown.
4. Turn the switch on to allow sufficient pressure to build up within the accumulator and check for continuity. If the ohmmeter shows continuity (pressure switch turned on), run the motor for 10 seconds more, then turn the switch off.

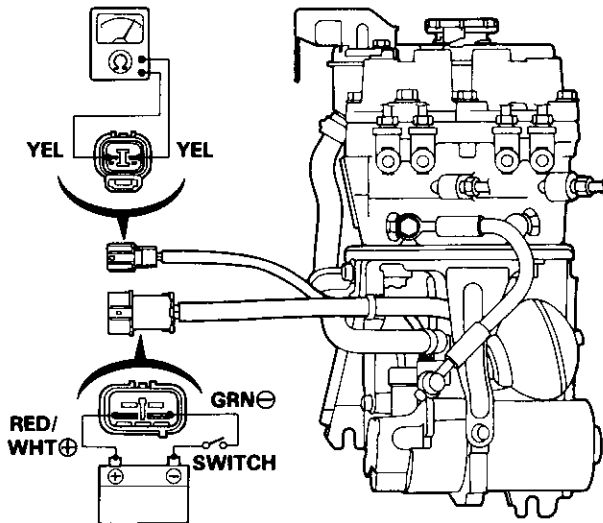

- Check if the solenoid hisses or squeaks. Replace the modulator if the solenoid hisses or squeaks.
- Check the pressure switch for continuity within 30 minutes. It is normal if there is continuity. If there is no continuity, a solenoid is faulty or high-pressure line leaks.

Pump

Pressure Switch Replacement

Removal

1. Secure the pump assembly in a vise.
2. Remove the banjo bolt, then remove the pressure switch from the pump housing.

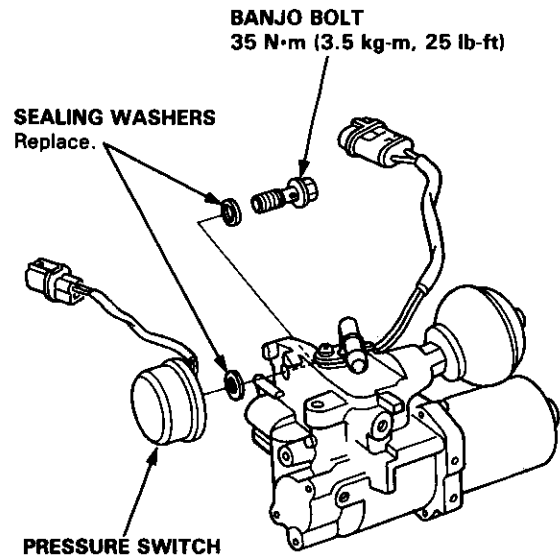

Installation

Install the pressure switch with the banjo bolt and new sealing washers, then tighten the bolt.



Accumulator

Disposal

▲ WARNING The accumulator contains high pressure nitrogen gas. Do not puncture, expose to the flame, or attempt to disassemble the accumulator or it may explode and severe personal injury may result.

1. Secure the pump assembly in a vise and remove the accumulator by turning it counterclockwise with a 19 mm open-end wrench.

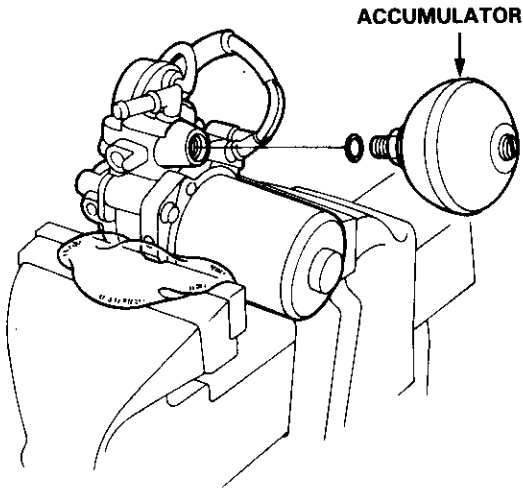

2. Secure the accumulator in a vise so that the relief plug points straight up.
3. Slowly turn the plug 3-1/2 turns and then wait three minutes for all pressure to escape.
4. Remove the plug completely and dispose of the accumulator.

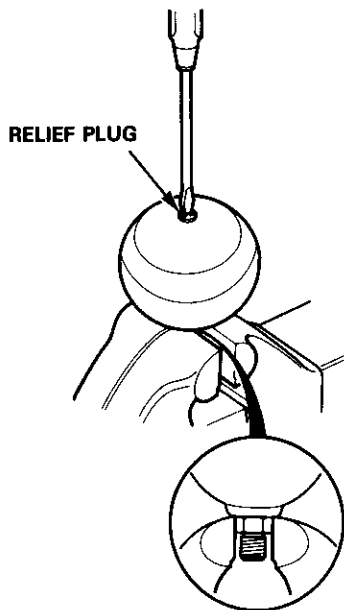

Bleeding

Air Bleeding with ALB Checker

CAUTION:

- Do not spill brake fluid on the car; it may damage the paint; if brake fluid does contact the paint, wash it off immediately with water.
- Make sure no dirt or other foreign matter is allowed to contaminate the brake fluid.
- Do not mix different brands of brake fluid as they may not be compatible.
- Do not reuse the drained fluid. Use only clean DOT 3 or 4 brake fluid.

1. Place the vehicle on level ground with the wheels blocked. Put the transmission in neutral for manual transmission models, and in **P** position for automatic transmission models. Release the parking brake.
2. Disconnect the ABS inspection connector (6P) from the cross-member under the passenger's seat and connect the ABS inspection connector (6P) to the ALB checker.

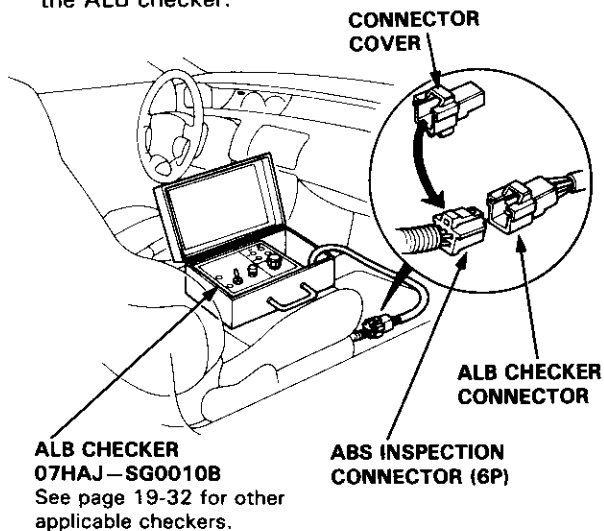

3. Fill the modulator reservoir to the MAX level line and install the reservoir cap.

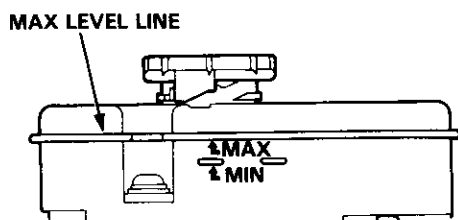

4. Start the engine and allow it to idle for a few minutes, then stop it. Check the fluid level in the modulator reservoir and refill to the MAX level line if necessary.
5. Bleed high-pressure fluid from the maintenance bleeder with the special tool.

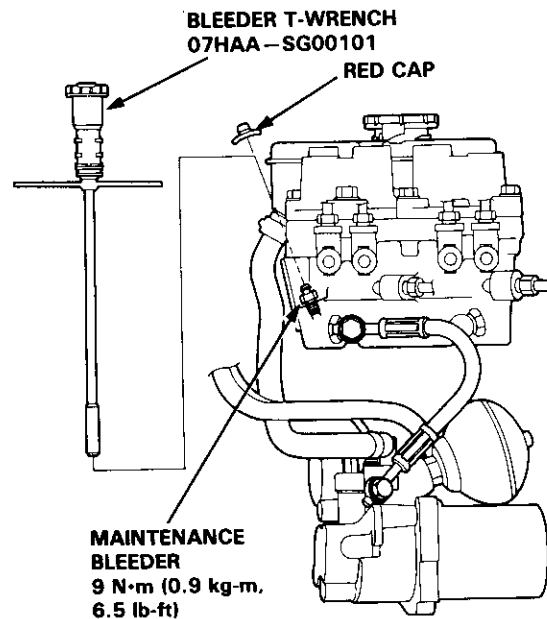

6. Start the engine and allow it to idle for a few minutes, then stop it. Check the fluid level in the modulator reservoir and refill to the MAX level line if necessary.
7. Turn the Mode Selector switch of the checker to 2.
8. While depressing the brake pedal firmly, push the Start Test switch to operate the modulator. There should be kickback on the brake pedal. If not, repeat steps 5 to 8.

NOTE: Continue to depress the brake pedal firmly when operating the checker.

9. Turn the Mode Selector to 3, 4, and 5. Perform step 8 for each of the test mode positions.
10. Refill the modulator reservoir to the MAX level line and install the reservoir cap.

WARNING Disconnect the ALB Checker before driving the car. A collision can result from a reduction or complete loss of braking ability, causing severe personal injury or death.

Electronic Components

ABS Control Unit Replacement

1. Remove the right quarter trim panel.
2. Disconnect the ABS control unit connectors.
3. Remove the ABS control unit attaching bolts, then remove the ABS control unit.

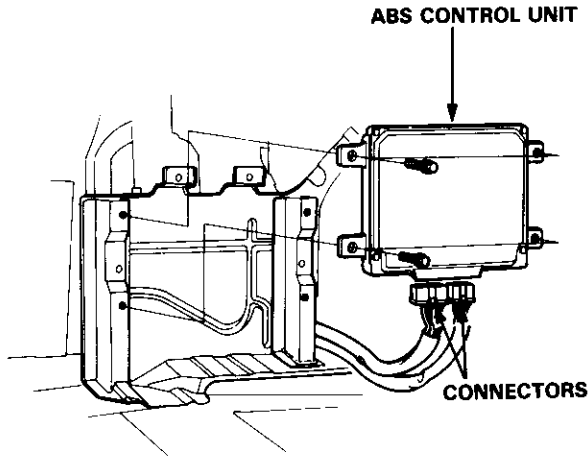

4. Install the ABS control unit in the reverse order of removal.

Relay Inspection

1. Remove the fail-safe relays and motor relay (location: page 19-50).
2. Check for continuity between the terminals C and D.
There should be continuity.
3. Check for continuity between the terminals A and B.
There should be continuity when the battery is connected between the terminals C and D.
There should be no continuity when the battery is disconnected.

<Fail-safe Relay:>

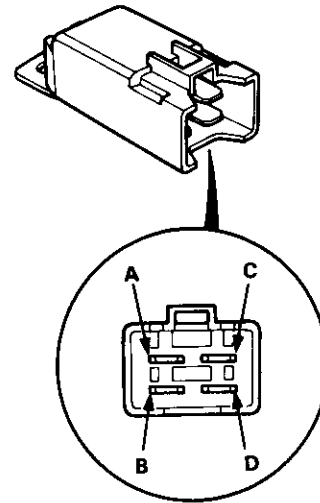

<Motor Relay:>

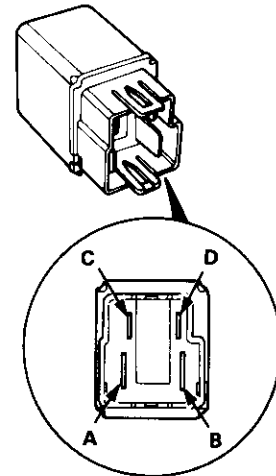

Pulsers/Wheel Sensors

Inspection

Front

1. Check the pulser for chipped or damaged teeth and replace if necessary.
2. Measure the air gap between the sensor and pulser all the way around while rotating the driveshaft by hand.

Standard: 0.4–1.0 mm (0.02–0.04 in)

NOTE: If the gap exceeds 1.0 mm (0.04 in) at any point, the probability is a distorted knuckle, which should be replaced.

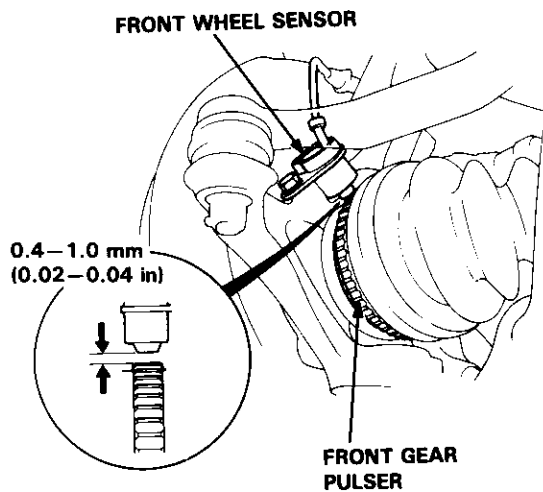

Rear

1. Remove the rear caliper assembly.
2. Remove the rear brake disc.
3. Check the rear pulser for chipped or damaged teeth and replace if necessary.
4. Measure the air gap between the sensor and pulser all the way around while rotating the hub bearing unit by hand.

Standard: 0.4–1.0 mm (0.02–0.04 in)

NOTE: If the gap exceeds 1.0 mm (0.04 in) at any point, the probability is a distorted knuckle, which should be replaced.

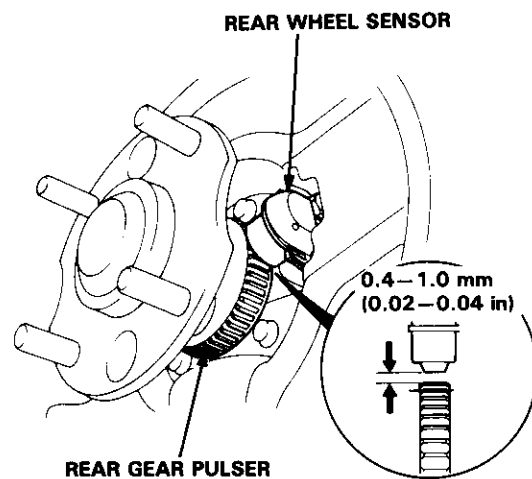



Wheel Sensor Replacement

Front

NOTE:

- Be careful when installing the sensors to avoid twisting the wires.
- After sensor replacement, confirm proper operation (see page 19-53).

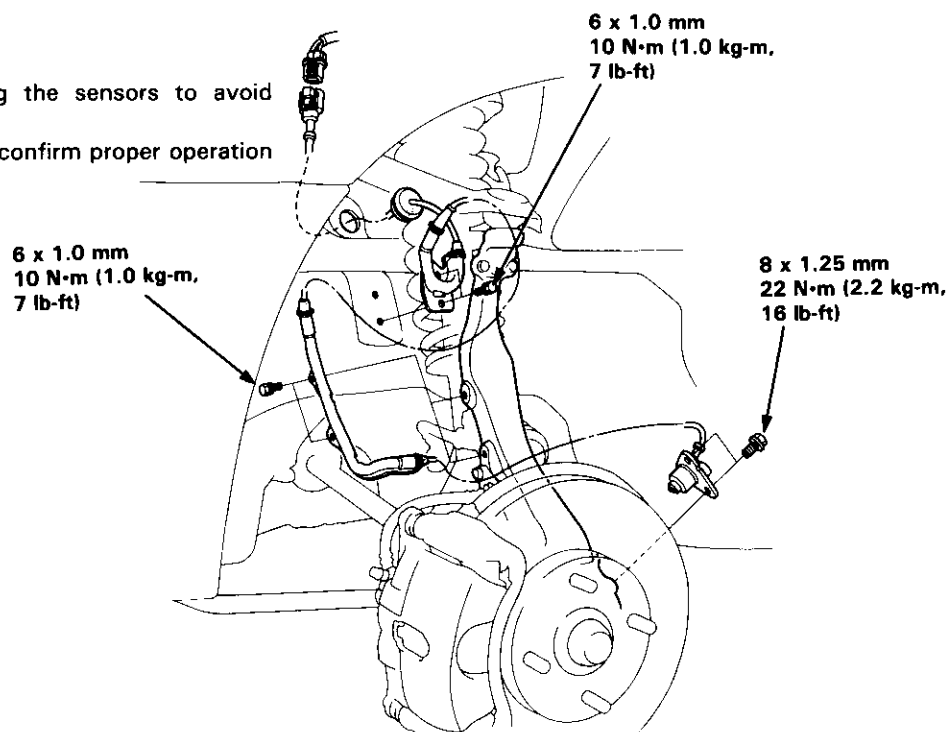

Rear

NOTE:

- Be careful when installing the sensors to avoid twisting the wires.
- After sensor replacement, confirm proper operation (see page 19-53).

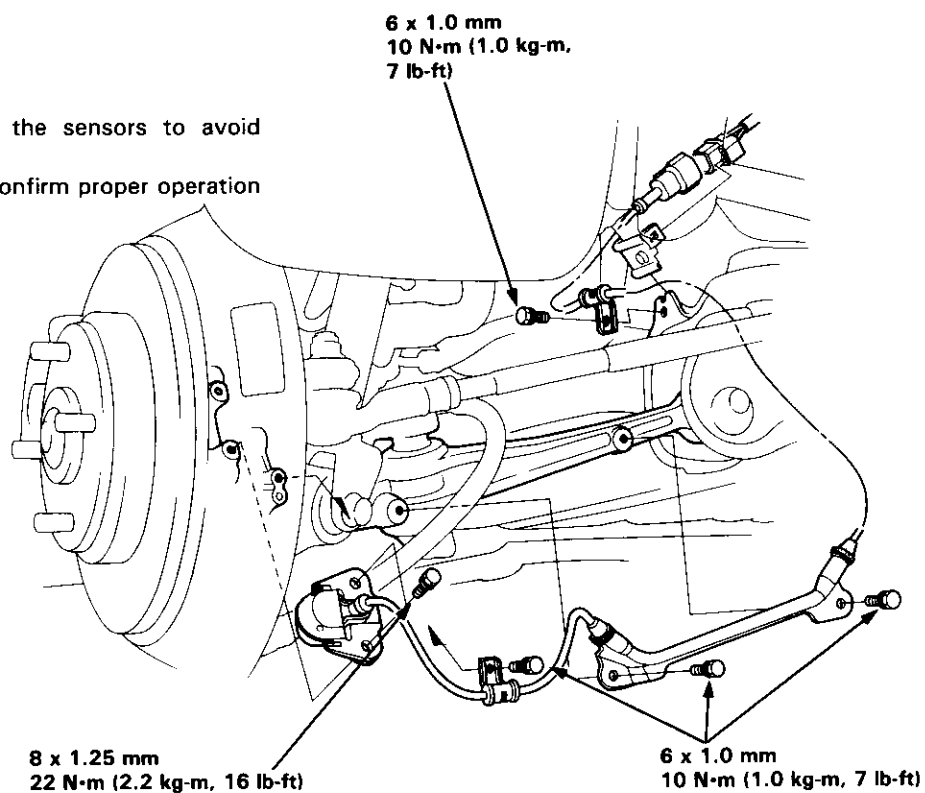

Body

Bumpers

Front Replacement	20-58
Front Disassembly	20-60
Rear Replacement	20-61
Rear Disassembly	20-62

*Carpet

Replacement	20-48
-------------------	-------

*Consoles

Replacement	20-50
-------------------	-------

*Dashboard

Component Removal/Installation	20-51
Replacement	20-55

Doors

Index	20-2
Door Panel/Plastic	
Cover Replacement	20-3
Outer Handle Replacement	20-5
Latch Replacement	20-6
Glass/Regulator Replacement ...	20-7
Outer Molding Replacement	20-9
Weatherstrips Replacement	20-9
Glass Adjustment	20-10
Position Adjustment	20-11
Striker Adjustment	20-12

*Frame Repair Chart

Fuel Lid

Opener and Fuel Lid	
Latch Replacement	20-67
Opener Cable Replacement	20-66

Headliners

Replacement	20-36
-------------------	-------

Hood

Replacement/Adjustment	20-63
Opener and Latch Replacement	20-63
Hood Edge Protector Replacement	20-69

Interior Trims

Replacement	20-37
-------------------	-------

Mirrors

Power Door Mirror Replacement ..	20-12
Mirror Holder Replacement	20-13
Rearview Mirror Replacement	20-13

Rear Emblem

Installation	20-70
--------------------	-------

Roof Molding/Side Sill Panel

Replacement	20-68
-------------------	-------

Seats

Front Removal	20-38
Front Replacement	20-38
Front Seat Cover Replacement	20-40
Rear Replacement	20-41

Seat Belts

Front Replacement	20-43
Rear Replacement	20-45
Inspection	20-46
Child Seat Anchor Plate	20-47

Sub-frame

Sunroof

Index	20-28
Troubleshooting	20-29
Sliding Panel Height Adjustment ...	20-29
Rear Edge Closing Adjustment	20-30
Sunroof Liner and Sliding Panel	
Replacement	20-30
Sunroof Repair/Installation	20-31
Motor, Drain Tube, and Frame	
Replacement	20-32
Panel Stay/Slider, Lifter and	
Guide Rails Replacement	20-33
Opening Drag Check	
(Motor Removed)	20-34
Closing Force Check	
(Motor Installed)	20-35

Trunk Lid

Replacement/Adjustment	20-64
Opener Replacement	20-67
Trunk Lid Latch Replacement	20-65
Opener Cable Replacement	20-66
Opening Weatherstrip/License	
Plate Trim Replacement	20-69
Trunk Spoiler Replacement	20-70

Windshield/Rear Window/ Quarter Glass

Index	20-14
Windshield	
Removal	20-15
Installation	20-16
Rear Window	
Removal	20-20
Installation	20-21
Quarter Glass	
Removal	20-25
Installation	20-25



Doors

Index

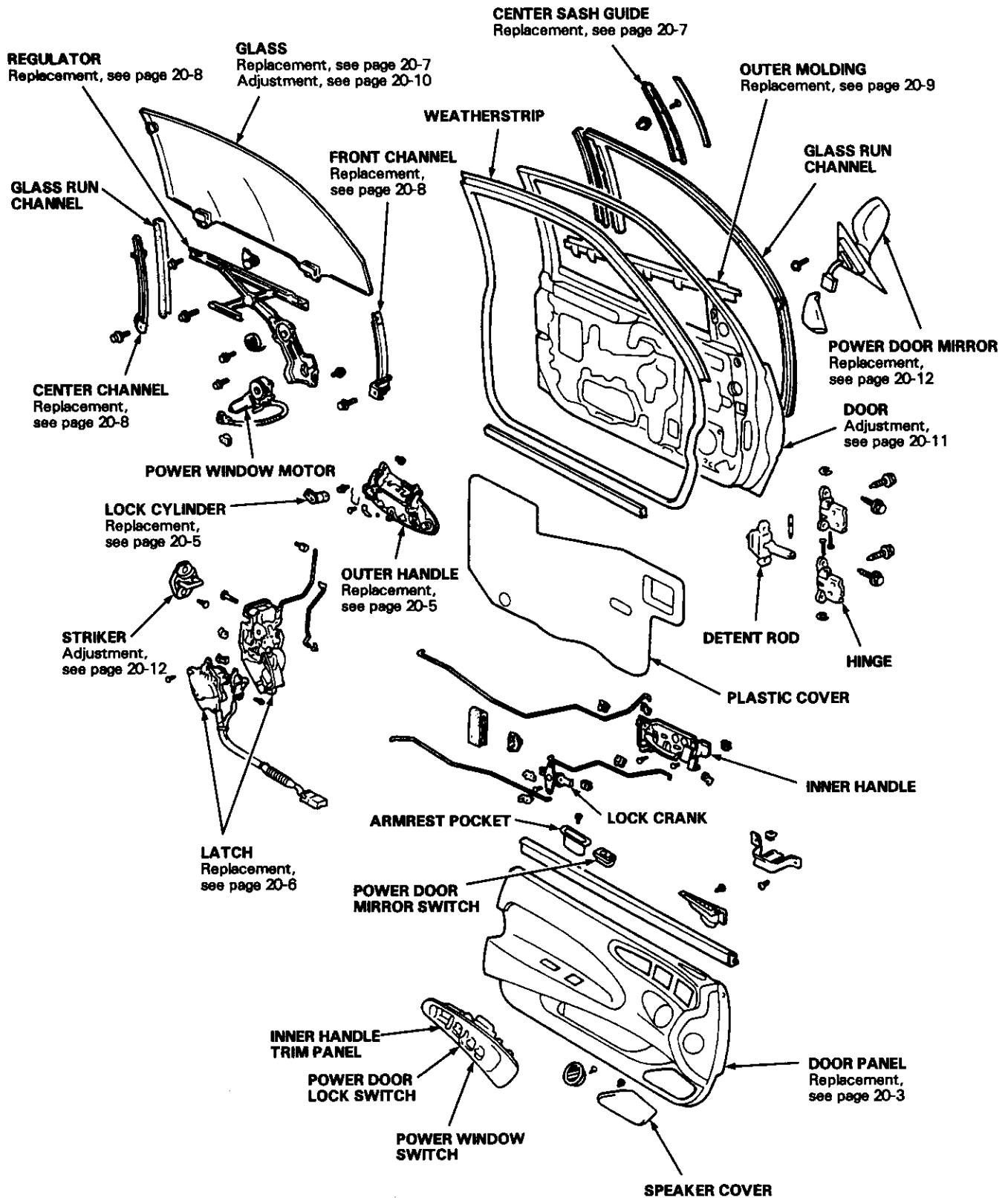



Door Panel/Plastic Cover Replacement

1. Pry the cap, then remove the screw. Remove the clips and disconnect the connectors, then remove the inner handle trim panel.

NOTE:

- Remove the hook by sliding the inner handle trim panel backward while pulling the handle, then remove the inner handle trim panel.
- Take care not to scratch the inner handle trim panel.

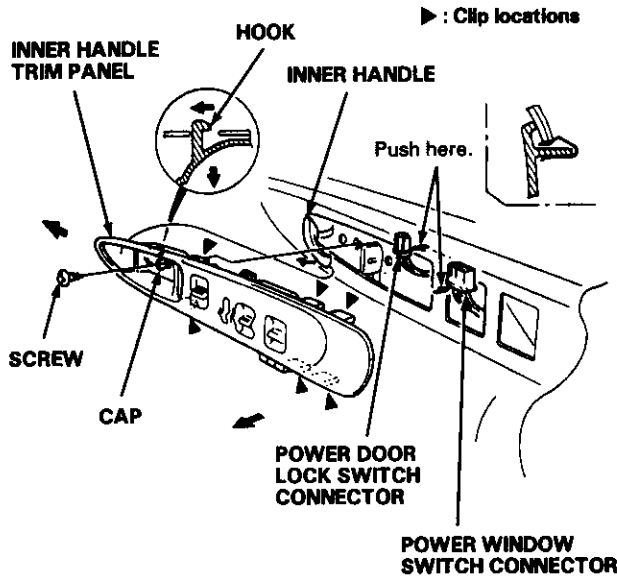

2. Pry the cap and remove the screw, then remove the armrest pocket.

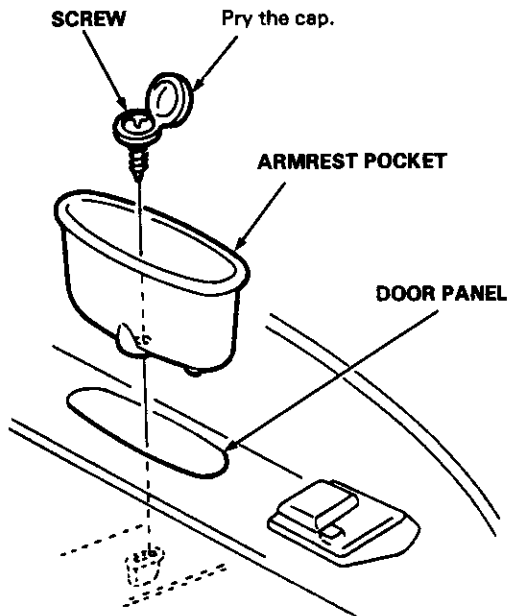

NOTE:

Remove the door panel with as little bending as possible to avoid creasing or breaking it.

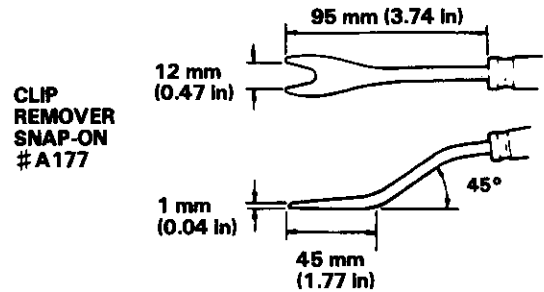

3. Remove the screws and clips (see clip remover) attaching the door panel. Remove the door panel by pulling it upward. Disconnect the power door mirror switch connector.

► : Clip locations (9)

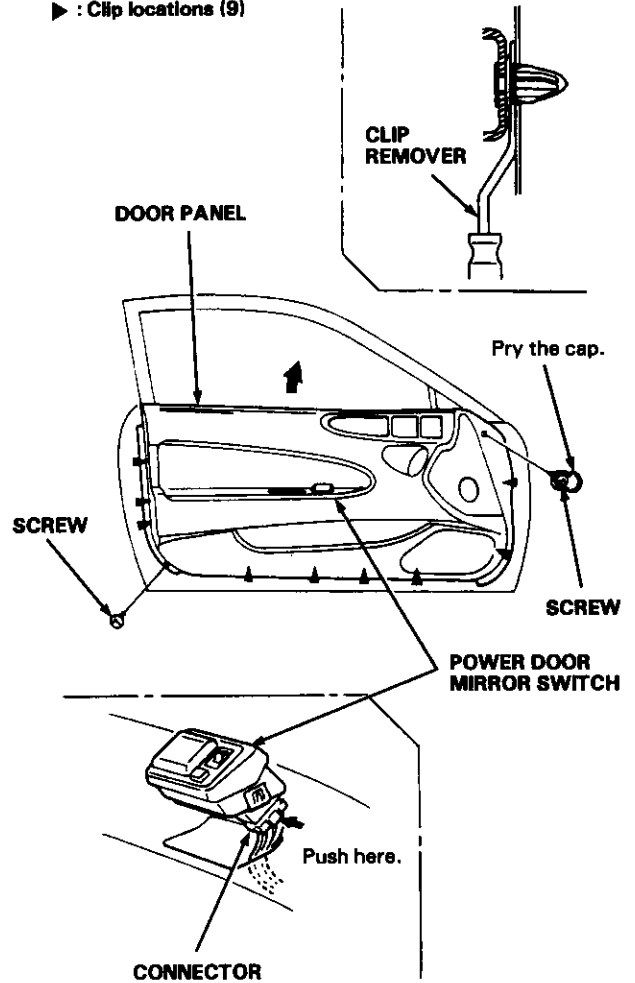

(cont'd)

Doors

Door Panel/Plastic Cover Replacement (cont'd)

4. Remove the grommets, bracket and door lock unit, then carefully remove the plastic cover.

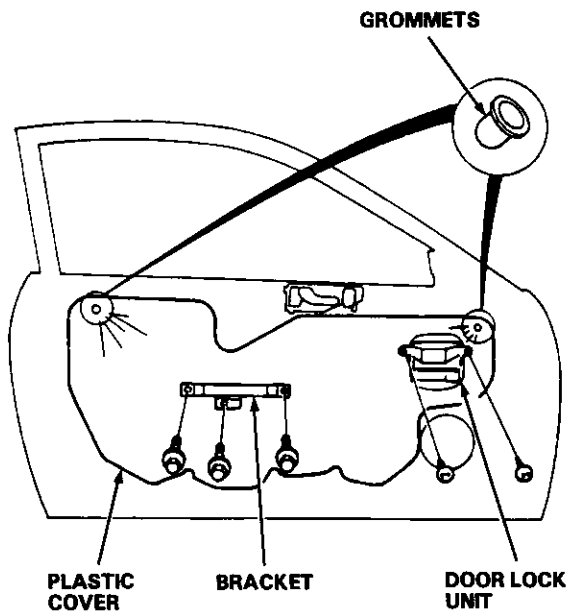

5. Install the door panel and plastic cover in the reverse order of removal.

NOTE:

- Make sure the door harnesses and connectors are fastened correctly on the door.

●: Harness clip locations

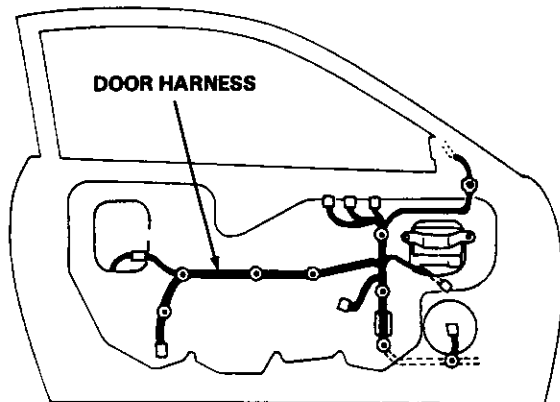

- Apply adhesive along the edge where necessary to maintain a continuous seal and prevent water leaks.

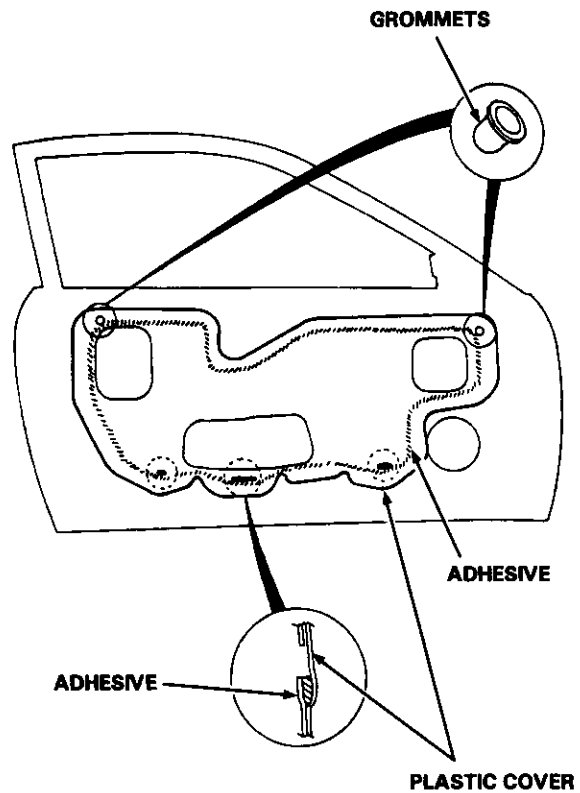

- Before tightening the door panel mounting screws, make sure the door harnesses are not pinched.



Outer Handle Replacement

NOTE:
Raise the glass fully.

1. Remove:
 - Door panel (see page 20-3)
 - Plastic cover (see page 20-4)
2. Peel off the access hole seal.
3. Remove the mounting bolts and clip, then pull the outer handle out.

CAUTION:
Use protective tape around the outer handle to prevent damage.

NOTE:
Do not drop the mounting bolts and clip inside the door.

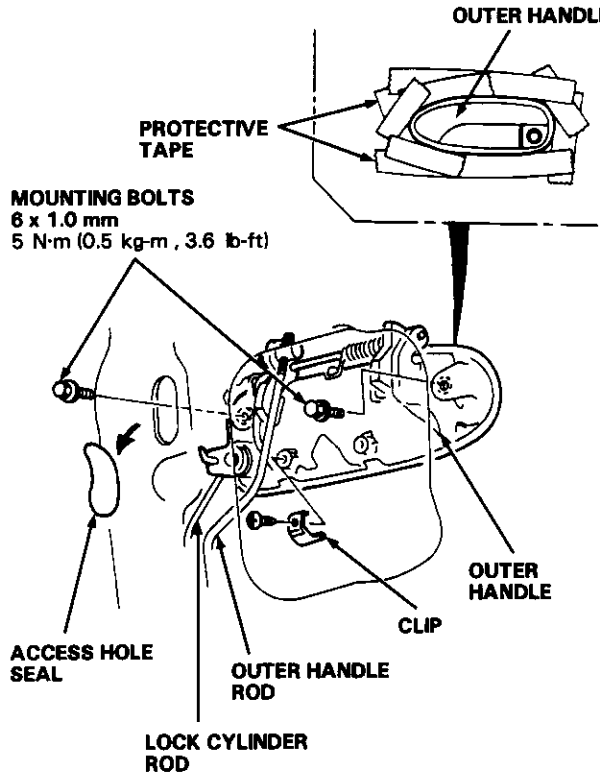

4. Pry the outer handle rod out of its joint using a flat tip screwdriver.

CAUTION:
When prying with a flat tip screwdriver, wrap it with protective tape to prevent damage.

NOTE:

- To ease reassembly, note the location **A** of the outer handle rod on the joint before disconnecting it.
- Take care not to damage the joint.

5. Pry the lock cylinder rod out, then remove the outer handle.

NOTE:
Take care not to bend the lock cylinder rod.

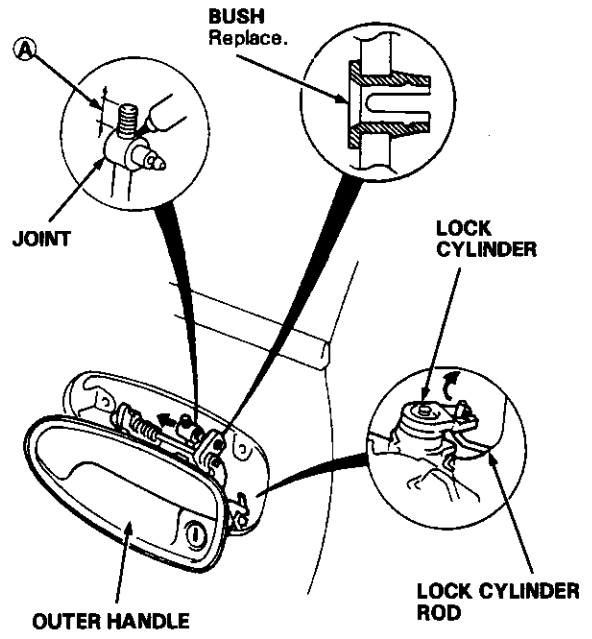

6. Pull out the retainer clip, then remove the lock cylinder.

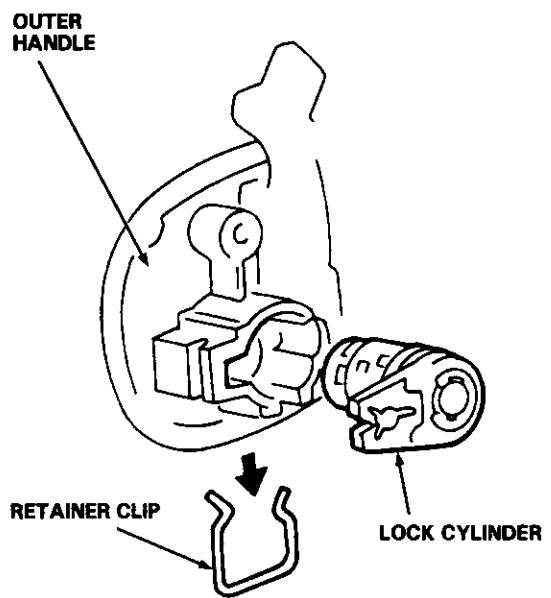

7. Installation is the reverse of the removal procedure.

Doors

Latch Replacement

NOTE:

Raise the glass fully.

1. Remove:
 - Door panel (see page 20-3)
 - Plastic cover (see page 20-4)
 - Center sash (see page 20-7)
 - Outer handle (see page 20-5)
2. Disconnect the inner handle rod and lock rod from the inner handle and lock crank. Remove the screws, then remove the inner handle and lock crank.

NOTE:

Take care not to bend the rods.

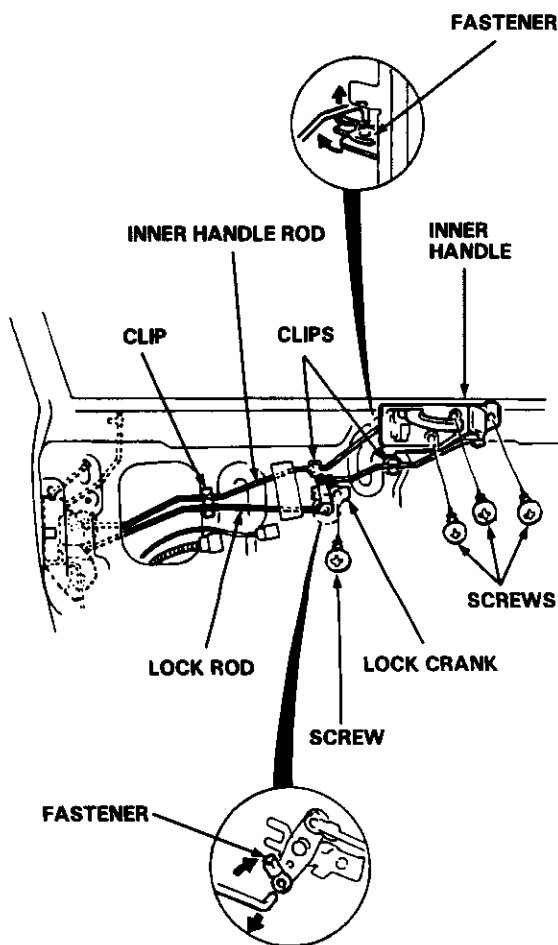

3. Disconnect the connector and harness clip from the door. Remove the mounting screws, then remove the latch through the hole in the door.

NOTE:

Take care not to bend the rods.

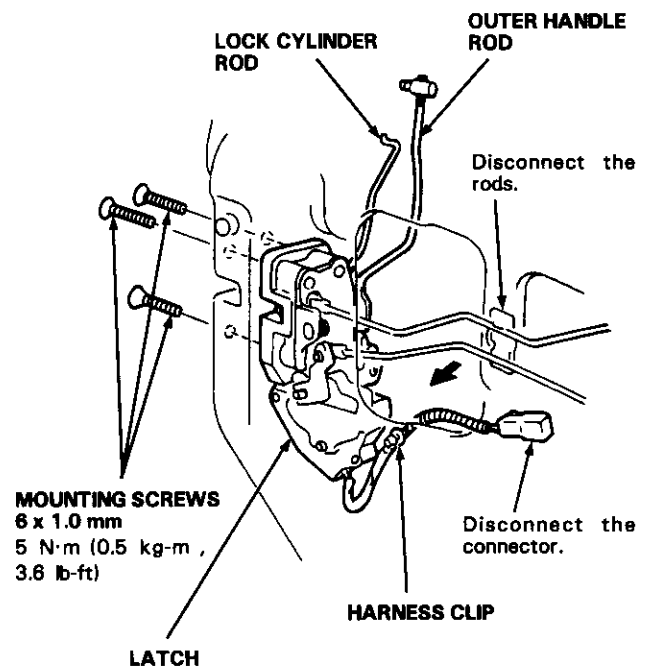

4. Installation is the reverse of the removal procedure.

NOTE:

Make sure the rods and connector are fastened correctly.



Glass/Regulator Replacement

1. Remove:
 - Door panel (see page 20-3)
 - Plastic cover (see page 20-4)
2. Lower the glass fully.
3. Peel off the sash guide cover and remove the screws, then remove the center sash guide from the door.

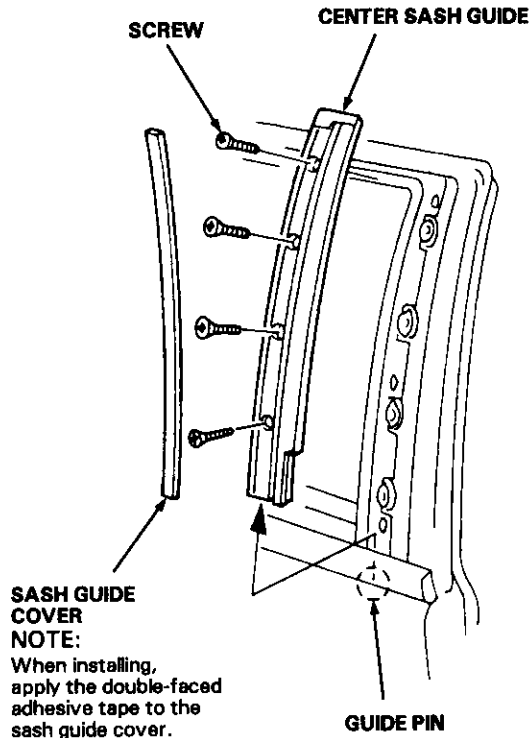

4. Carefully move the glass until you can see the glass mounting bolts, then loosen the glass mounting bolts. Slide the guide to the rear, then remove the glass.

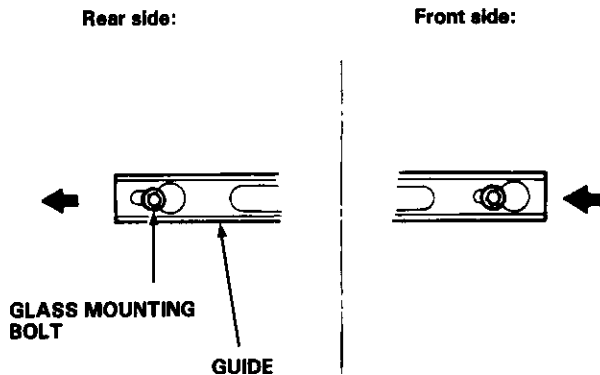

5. Carefully pull the glass out through the window slot.

NOTE:
Take care not to drop the glass inside the door.

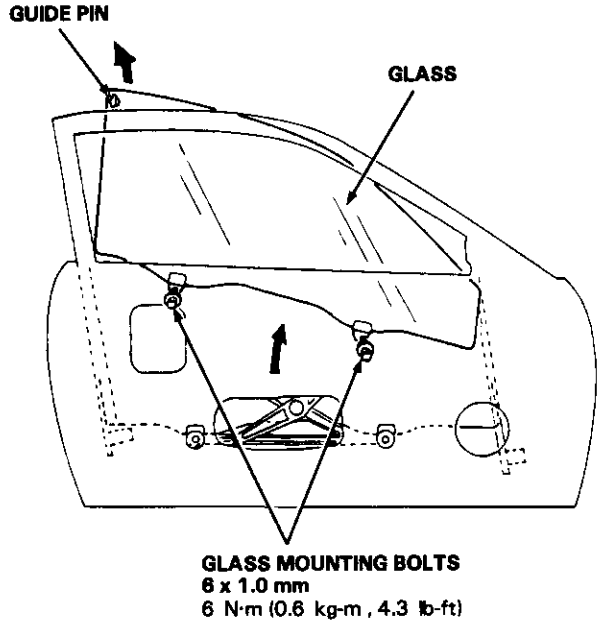

- Check the guide pin for damage, and replace if necessary.

NOTE:
Scribe a line around the guide pin to show the original location.

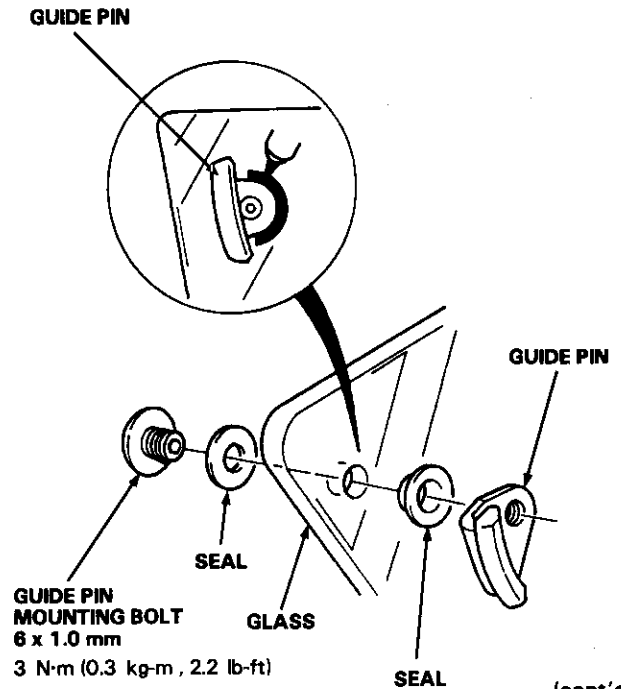

(cont'd)

Doors

Glass/Regulator Replacement (cont'd)

6. Peel the glass run channel out of the front channel.
7. Remove the mounting bolts, then remove the front channel and center channel.

NOTE:

After installing, make sure the glass run channel is not twisted.

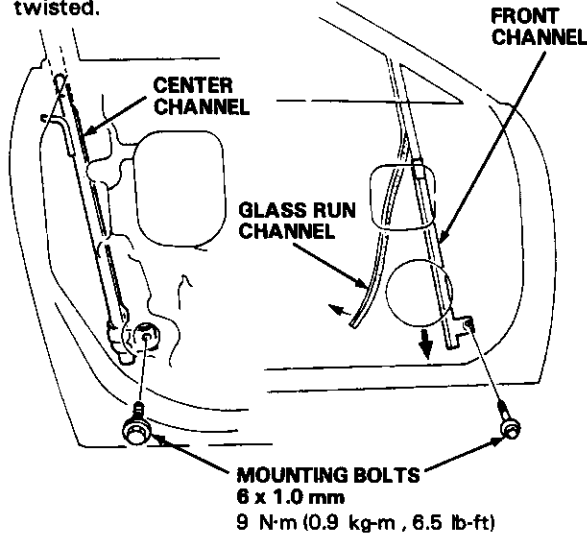

NOTE:

To install, fit the glass run channel into the front and center channels as shown.

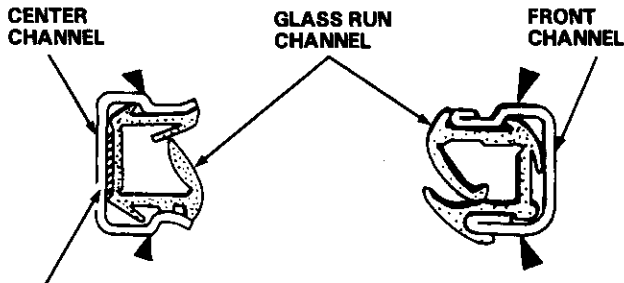

NOTE:

Apply the adhesive to the shadowed area.

8. Remove the two mounting bolts, two roller guide bolts and loosen the two mounting bolts. Disconnect the connector. Remove the regulator through the center hole in the door.

NOTE:

Scribe a line around the roller guide bolt to show the original adjustment.

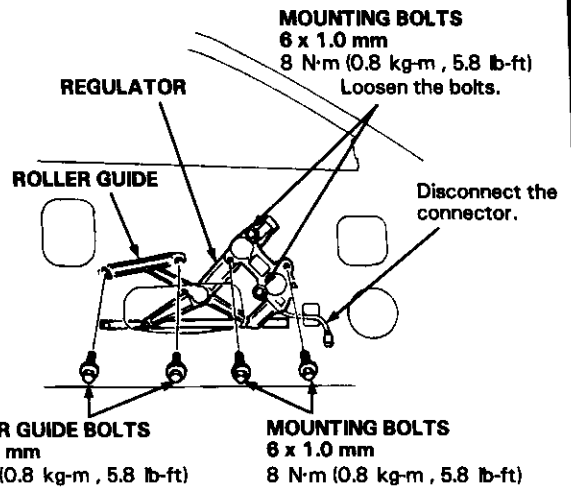
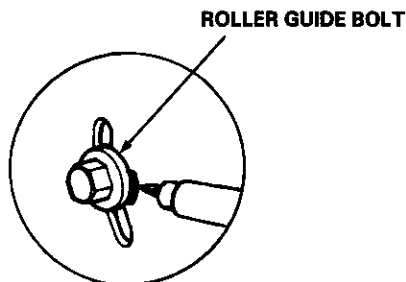

ROLLER GUIDE BOLTS
6 x 1.0 mm
8 N-m (0.8 kg-m, 5.8 lb-ft)

MOUNTING BOLTS
6 x 1.0 mm
8 N-m (0.8 kg-m, 5.8 lb-ft)

9. Grease all the sliding surfaces of the regulator where shown.
10. Before removing the power window motor, mark the location by scribing a line across the sector gear and regulator. Install using the motor mounting bolts. Move the regulator to the original position by connecting a 12 V battery to the power window motor (see section 23).

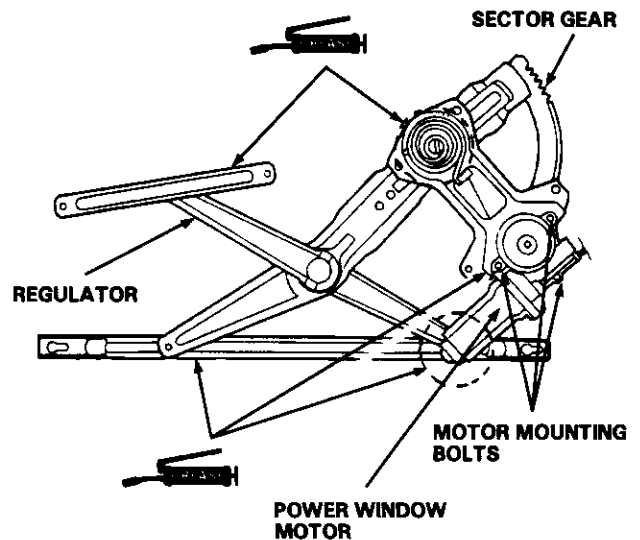

11. Installation is the reverse of the removal procedure.
12. Roll the glass up and down to see if it moves freely without binding. Also make sure that there is no clearance between the glass and glass run channel when the glass is closed. Adjust the position of the glass as necessary (see page 20-10).
13. Attach the door harness to the door correctly (see page 20-4).
14. When reinstalling the plastic cover, apply adhesive along the edge where necessary to maintain a continuous seal and prevent water leaks (see page 20-4).



Outer Molding Replacement

Remove:

- Door panel (see page 20-3)
- Plastic cover (see page 20-4)
- Door mirror (see page 20-12)
- Glass (see page 20-7)

► : Clip locations

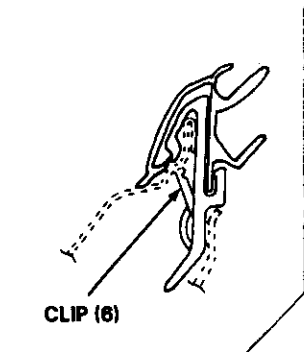

NOTE:

Take care not to twist or scratch the outer molding.

OUTER MOLDING

Starting at the rear, pry the outer molding up and detach the clips, then remove the outer molding.

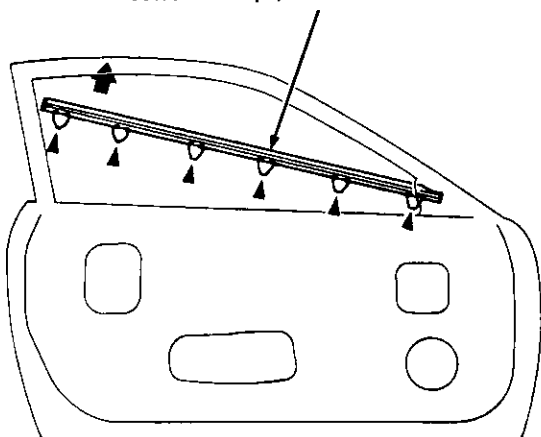

Installation is the reverse of the removal procedure.

NOTE:

- If necessary, replace any damaged clips.
- When installing, align the rear edge of the outer molding with the rear edge of the door.

Weatherstrips Replacement

► : Clip locations

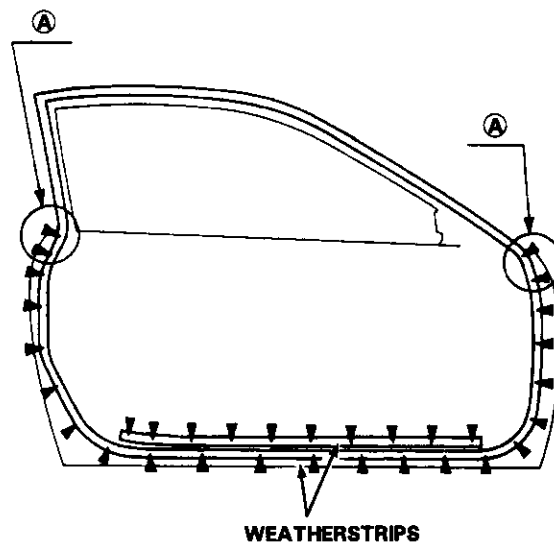
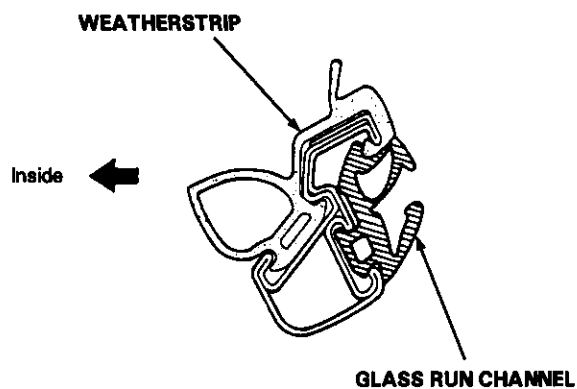
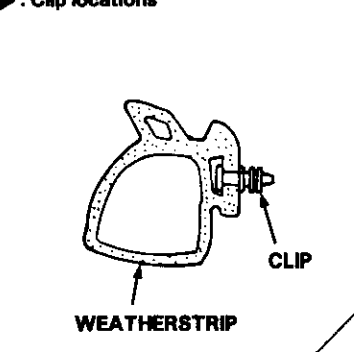

NOTE:

- Before installing the weatherstrip, apply clear sealant to the (A) areas of the door as shown.
- If necessary, replace any damaged clips.

Sealant: Cemedine # 8500

Doors

Glass Adjustment

NOTE:

- Place the vehicle on a firm, level surface when adjusting the glass.
- Check the weatherstrip and glass run channel for damage or deterioration and replace if necessary.

1. Remove the door panel and peel off the plastic cover (see pages 20-3, 4).
2. Connect the power window switch connector to the door harness connector.
3. Loosen the roller guide bolts and adjust the glass so it is parallel with the glass run channel.

NOTE:

Make sure the guide pin is in the center sash guide.

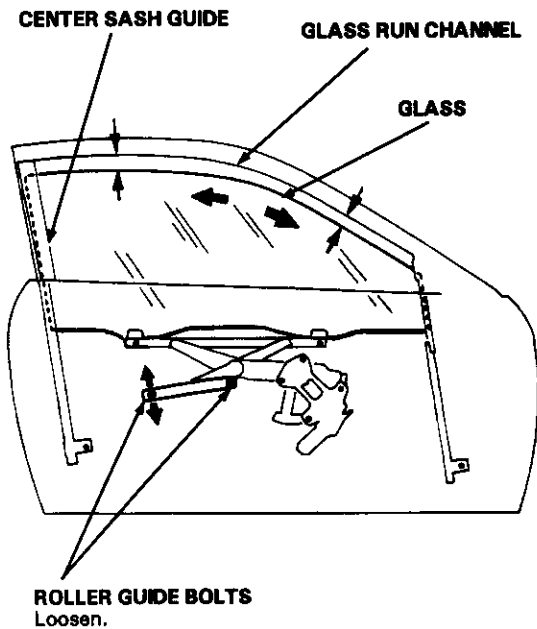
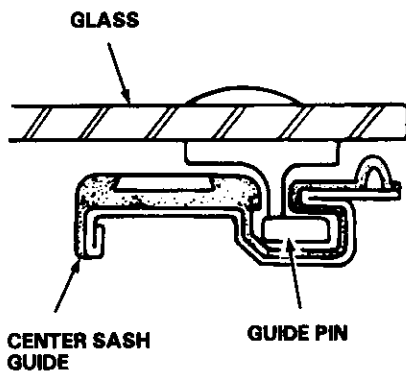

4. Raise the glass as far up as possible and hold it against the glass run channel. Then tighten the roller guide bolts.

5. Make sure the glass goes up and down smoothly.
6. If necessary, adjust the front channel and center channel.

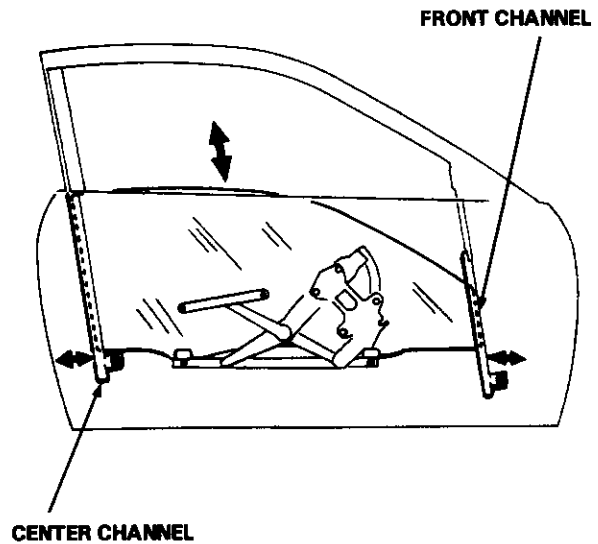

7. Raise the glass fully and check for gaps.

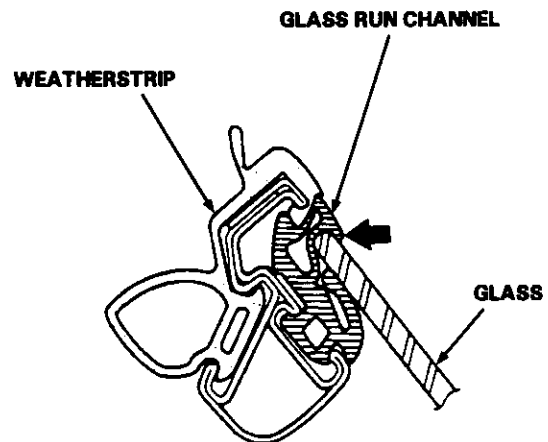

8. Check glass operation.

NOTE:

Check that the glass contacts the glass run channel evenly.



9. Check for water leaks.

NOTE:

Do not use high pressure water.

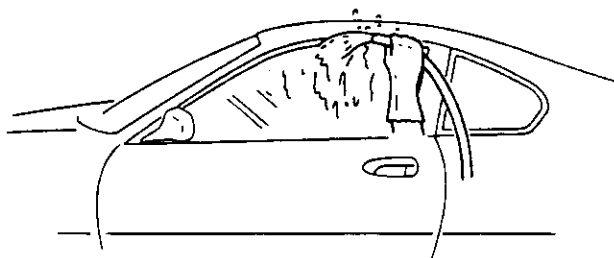

10. Route the door harnesses and connectors and fasten them to the door (see page 20-4).
11. Attach the plastic cover, then install the door panel (see pages 20-3, 4).

Position Adjustment

NOTE:

Place the vehicle on a firm, level surface when adjusting the doors.

After installing the door, check for a flush fit with the body, then check for equal gaps between the front and rear, and top and bottom door edges and the body. The door and body edges should also be parallel. Adjust at the hinges as shown.

CAUTION:

Place a shop towel on the jack to prevent damage to the door when the mounting bolts are loosened for adjustment.

DOOR MOUNTING BOLTS

8 x 1.25 mm

30 N·m (3.0 kg·m, 22 lb-ft)

Loosen the door mounting bolts slightly to move the door IN or OUT until it's flush with the body. If necessary, you can install a shim behind one hinge to make the door edges PARALLEL with the body.

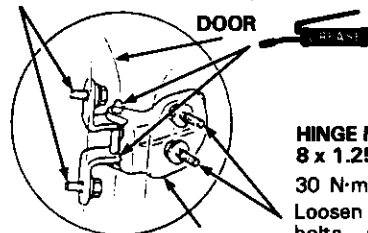

HINGE MOUNTING BOLTS

8 x 1.25 mm

30 N·m (3.0 kg·m, 22 lb-ft)

Loosen the hinge mounting bolts, and move the door BACKWARD or FORWARD, UP or DOWN as necessary to equalize the gaps.

Lower the glass.

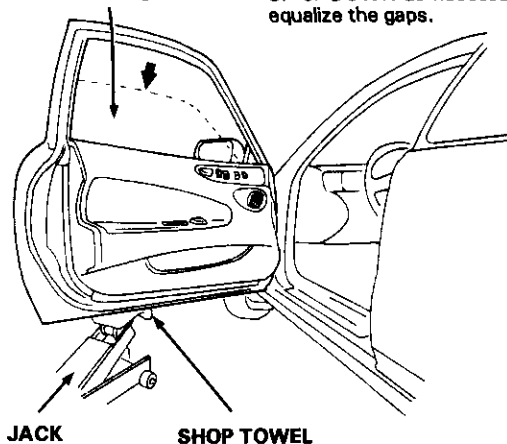

The door and body edges should be parallel.

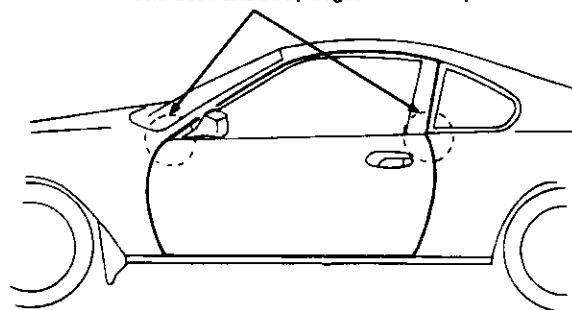

NOTE:

Check for water leaks.

Doors

Striker Adjustment

Make sure the door latches securely without slamming. If it needs adjustment:

1. Draw a line around the striker for reference.
2. Loosen the mounting screws and move the striker IN or OUT to make the latch fit tighter or looser. Move the striker UP or DOWN to align it with the latch opening. Then lightly tighten the mounting screws and recheck.

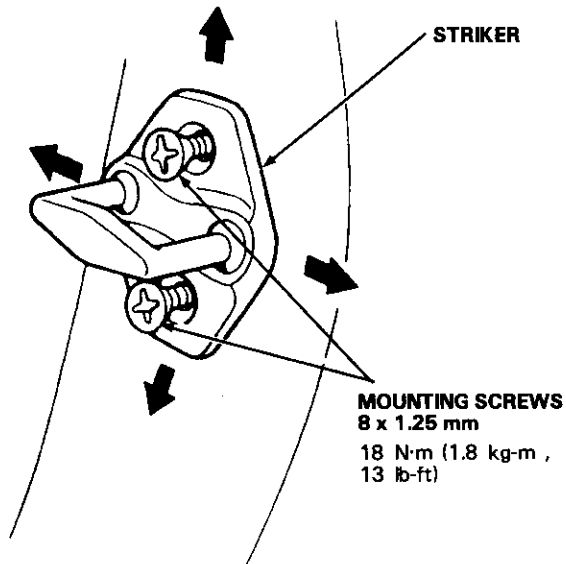

NOTE:

- Hold the outer handle out and push the door against the body to be sure the striker allows a flush fit.
- Do not tap the striker with a metal hammer to adjust the position.

3. If the door latches properly, tighten the mounting screws and recheck.

NOTE:

Replace the striker if it is cracked.

Mirrors

Power Door Mirror Replacement

1. Pry out the cover panel with a flat tip screwdriver, then remove the cover panel. Disconnect the connector.
2. Remove the mounting screws while holding the door mirror.

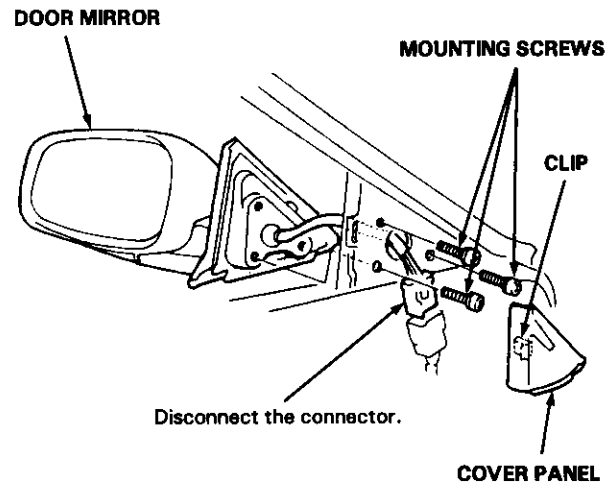

3. Installation is the reverse of the removal procedure.
4. Check for water leaks.

NOTE:

Do not use high pressure water.



Mirror Holder Replacement

1. Pry the mirror holder from the bottom until you can see the actuator, then detach the hooks using a flat tip screwdriver as shown.

NOTE:

Take care not to scratch the mirror housing.

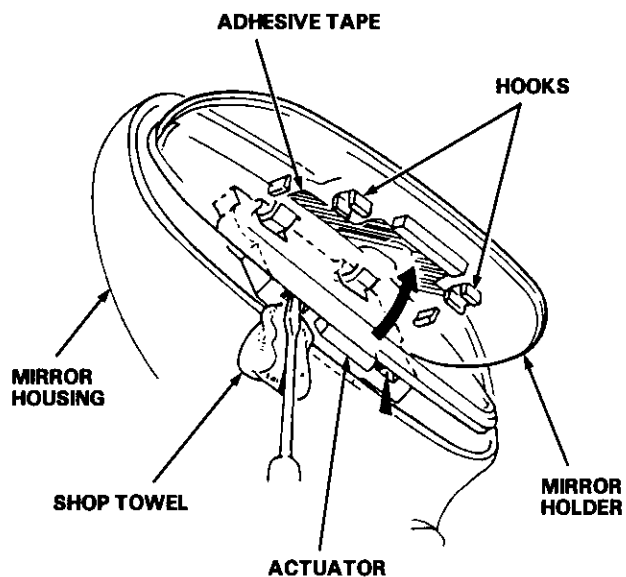

2. Disconnect the hooks and connector, then remove the mirror holder from the actuator.

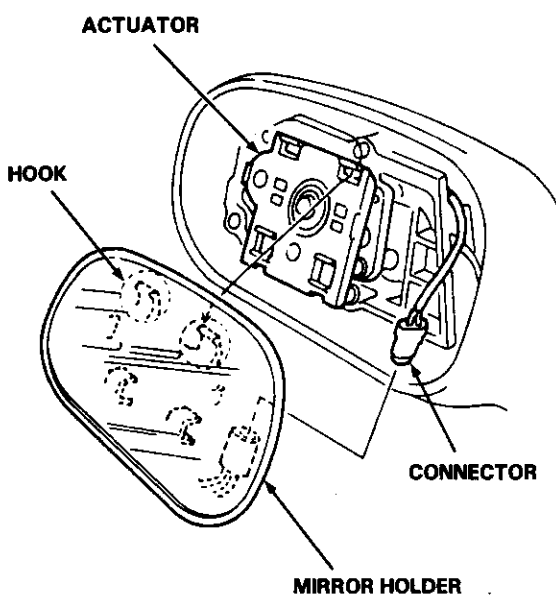

3. Installation is the reverse of the removal procedure.

Rearview Mirror Replacement

1. Carefully remove the cover with a flat tip screwdriver.
2. Loosen the lock bolt, then slide the mirror stay from the lug.

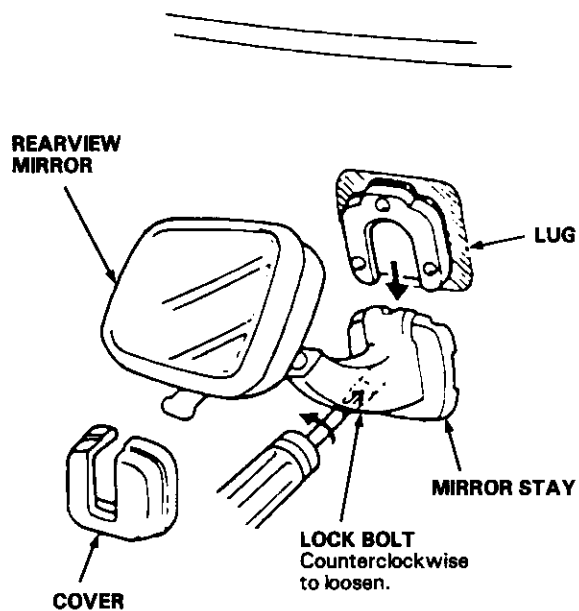

3. Remove the lock bolt, then remove the toothed lock washer and hold spring from the mirror stay.

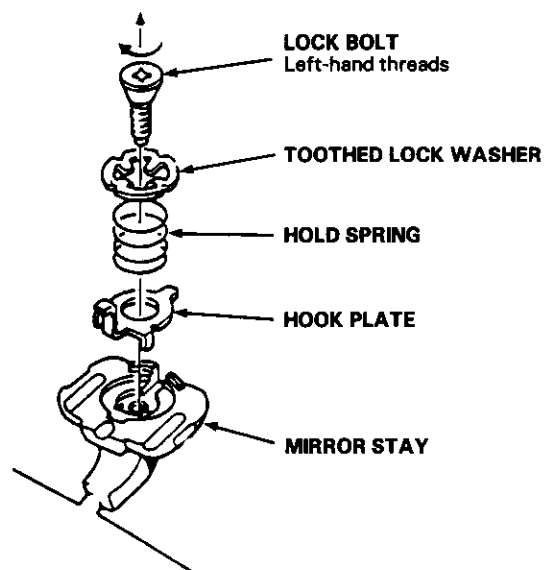

4. Installation is the reverse of the removal procedure.

Windshield, Rear Window, Quarter Glass

Index

(): Quantity of part used.

Windshield:

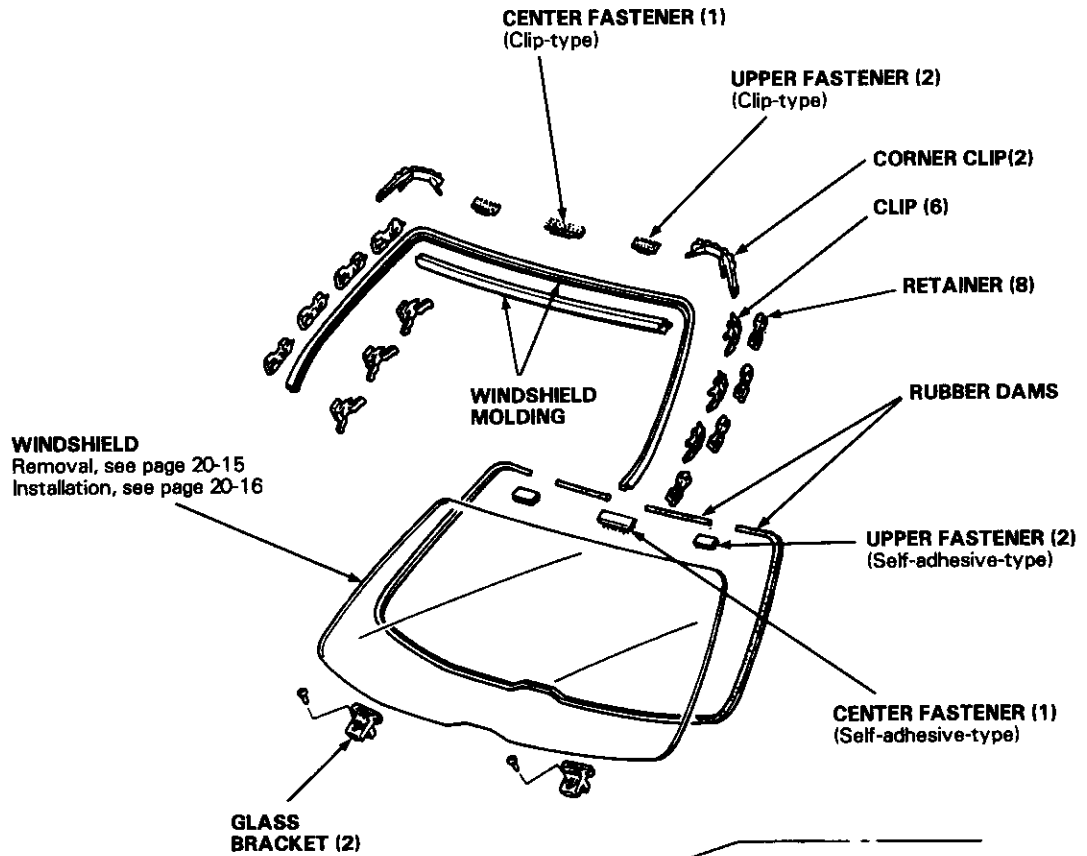

Rear Window:

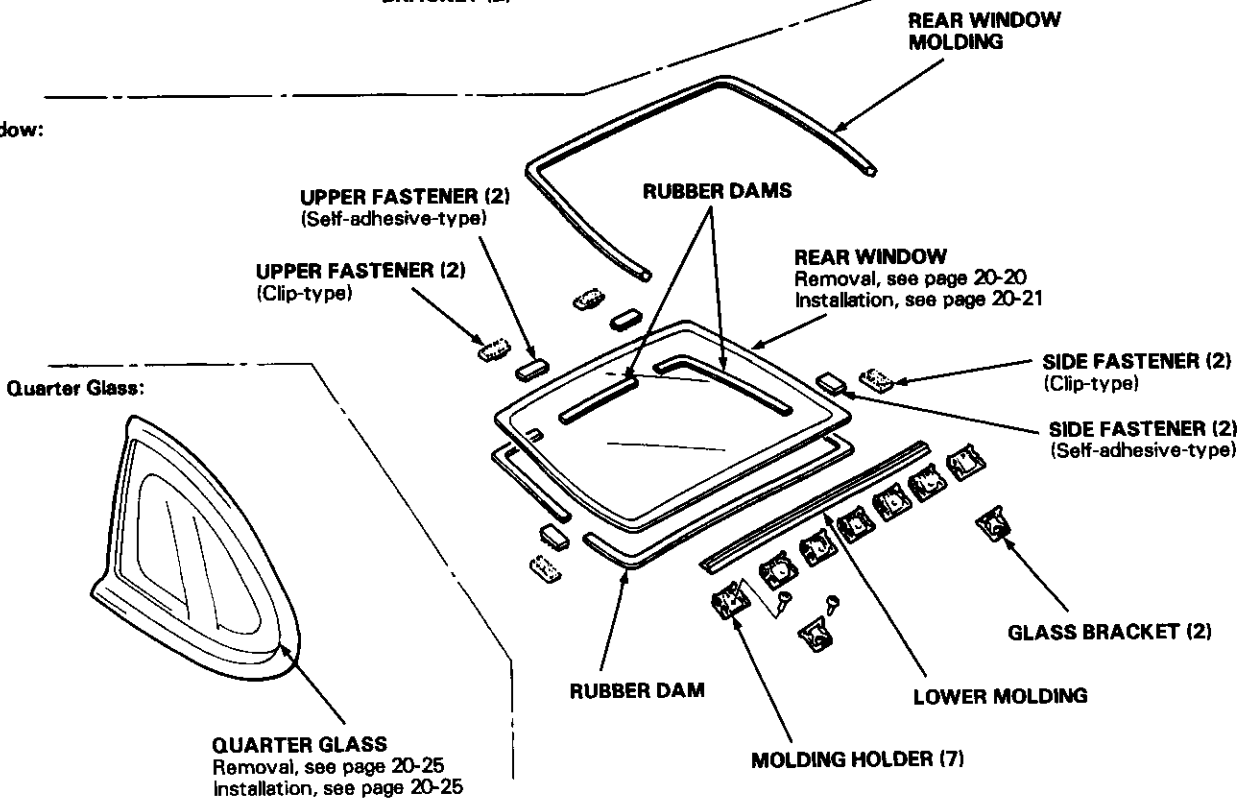



Windshield

Removal

CAUTION:

- Wear gloves to remove and install the windshield.
- Use seat covers to avoid damaging any surfaces.

1. To remove the windshield, first remove the:
 - Rearview mirror (see page 20-13)
 - Sunvisors (see page 20-36)
 - Front pillar trim (see page 20-37)
 - Front wipers and air scoop (see section 23)
2. Detach the clips from the retainers, then remove the side section of the windshield molding as shown.

NOTE:

If necessary, replace any damaged clips.

3. Peel off the upper section of the windshield molding.

NOTE:

When the upper section of the windshield molding removal is difficult, cut off the windshield molding.

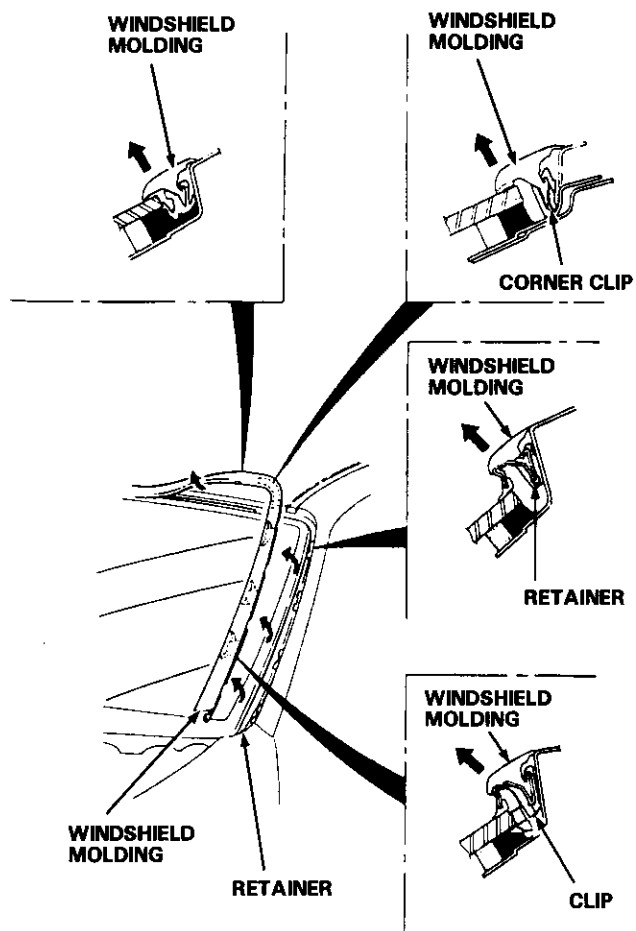

4. Pull down the front of the front headliner (see page 20-36).

CAUTION:

Take care not to bend the headliner excessively.

5. Remove the other retainers and fasteners from the body.
6. Apply protective tape along the edge of the dashboard and body as shown. Using an awl, make a hole through the rubber dam and adhesive from inside the car. Push the piano wire through the hole and wrap each end around a piece of wood.

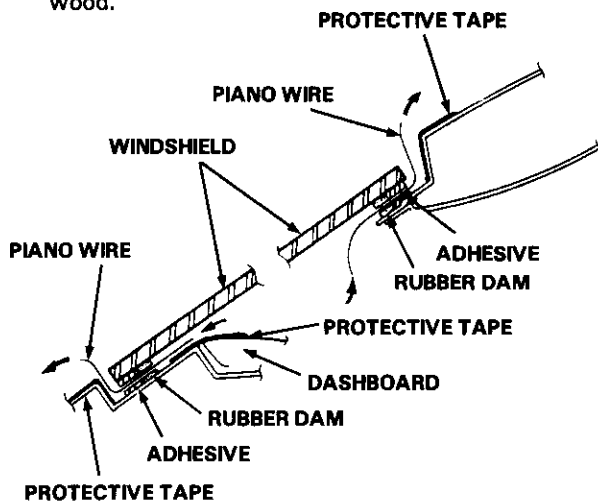

7. With a helper on the outside, pull the piano wire back and forth in a sawing motion and carefully cut through the adhesive around the entire windshield, then carefully remove the windshield.

CAUTION:

Hold the piano wire as close to the windshield as possible to prevent damage to the body and dashboard.

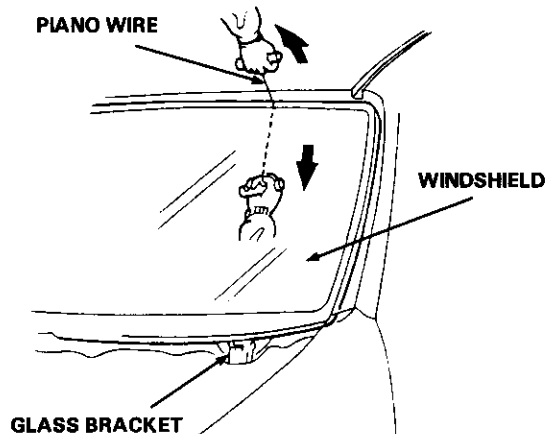

NOTE:

If necessary, remove the screw, then replace the glass bracket.

Windshield

Installation

1. Scrape the old adhesive smooth with a knife, to a thickness of about 2 mm (0.08 in) on the bonding surface around the entire windshield opening flange.

NOTE:

- Do not scrape down to the painted surface of the body; damaged paint will interfere with proper bonding.
- Remove the rubber dam and fasteners from the body.
- Mask off surrounding surfaces before painting.

2. Clean the body bonding surface with a sponge dampened in alcohol.

NOTE:

After cleaning, keep oil, grease or water from getting on the surface.

3. If the old windshield is to be reinstalled, use a putty knife to scrape off all traces of old adhesive, then clean the windshield surface with alcohol where new adhesive is to be applied.

NOTE:

Make sure the bonding surface is kept free of water, oil and grease.

CAUTION:

Avoid setting the windshield on its edges; small chips may later develop into cracks.

NOTE:

Clean the shadowed area.

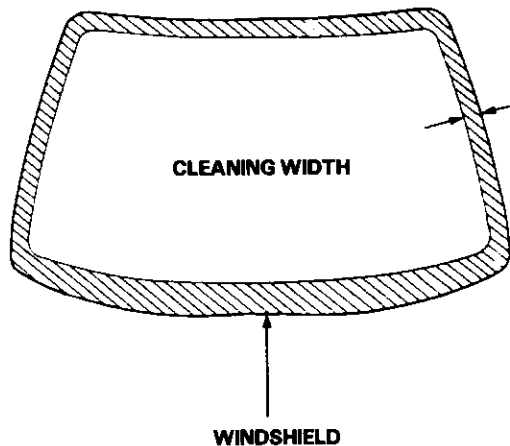

4. Glue the rubber dams to the inside face of the windshield as shown, to contain the adhesive during installation.

NOTE:

Be careful not to touch the windshield where adhesive will be applied.

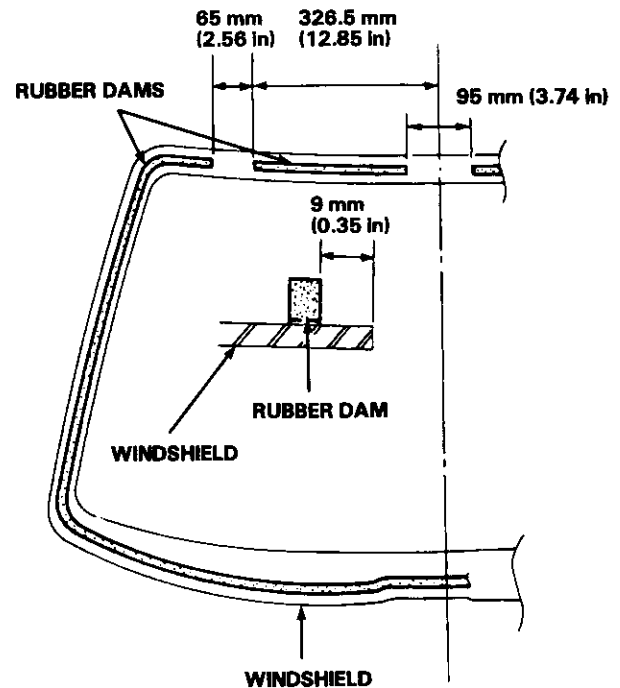

5. Glue the center and upper fasteners to the inside face of the windshield as shown.

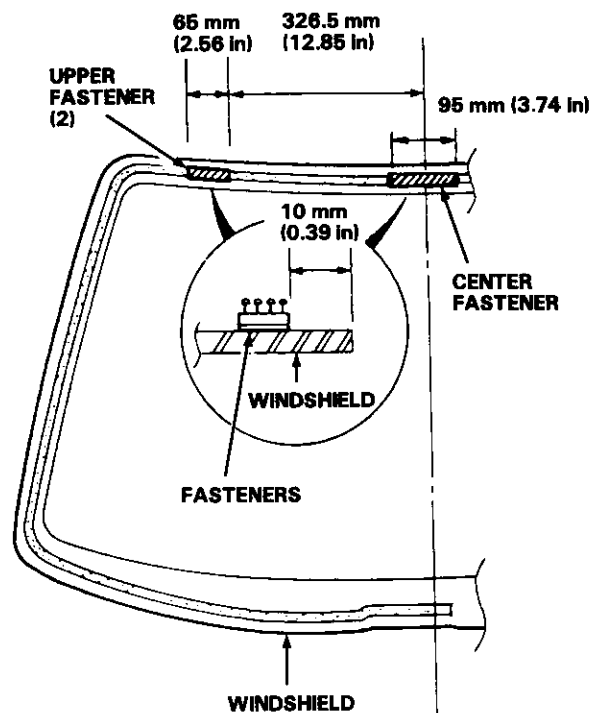



6. Install the glass brackets, retainers and fasteners to the body as shown.

NOTE:

Do not tighten the glass bracket mounting screws.

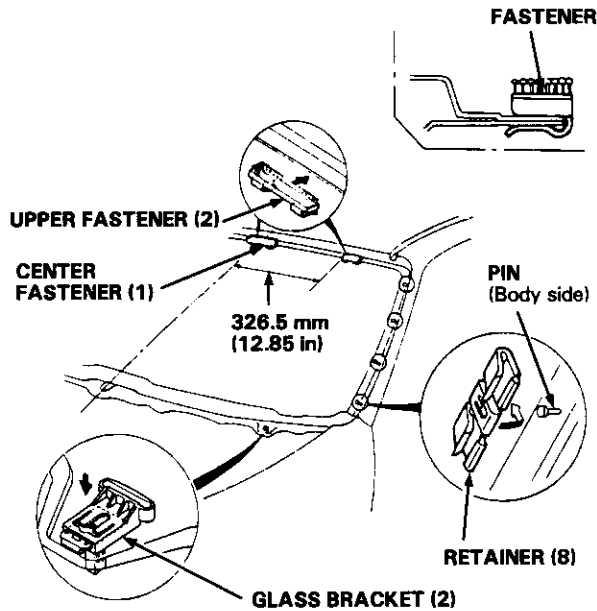

7. Set the windshield upright on the glass brackets, then center it in the windshield opening. Make alignment marks across the windshield and body with a grease pencil at the four points shown.

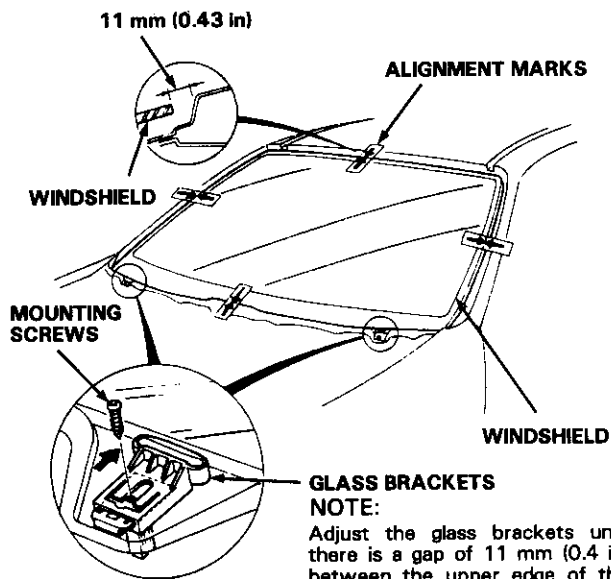

NOTE:
Adjust the glass brackets until there is a gap of 11 mm (0.4 in) between the upper edge of the windshield and the leading edge of the roof, then tighten the mounting screws.

8. With a sponge, apply a light coat of glass primer around the edge of the windshield as shown, then lightly wipe it off with gauze or cheesecloth.

NOTE:

- Do not apply body primer to the windshield, and do not get body and glass primer sponges mixed up.
- Never touch the primed surfaces with your hands. If you do, the adhesive may not bond to the windshield properly, causing a leak after the windshield is installed.
- Keep water, dust, and abrasive materials away from the primed surface.

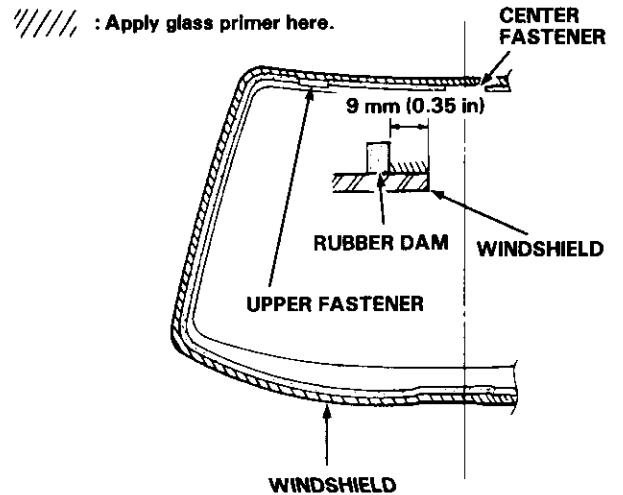

9. With a sponge, apply a light coat of body primer to the original adhesive remaining around the windshield opening flange. The windshield should be installed 10 minutes after you apply the body primer.

NOTE:

- Do not apply glass primer to the body, and be careful not to mix up glass and body primer sponges.
- Never touch the primed surfaces with your hands.
- Mask off the dashboard before painting the flange.

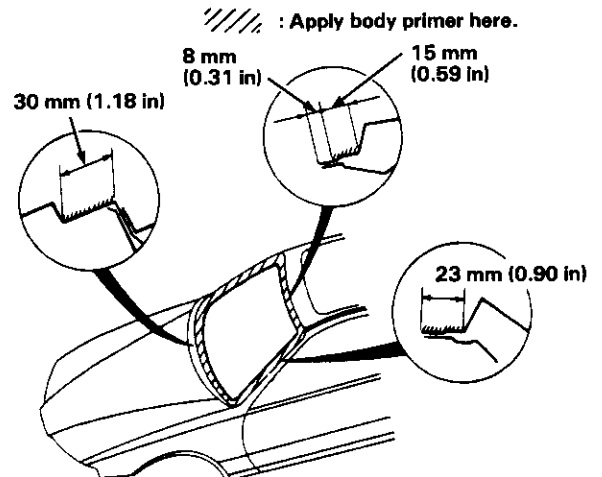

(cont'd)

Windshield

Installation (cont'd)

10. Thoroughly mix the adhesive and hardener together on a glass or metal plate with a putty knife.

NOTE:

- Clean a glass or metal plate with a sponge and alcohol before mixing.
- Follow the instructions that come with the adhesive.

11. Before filling a cartridge, cut the end of the nozzle as shown.

Cut nozzle end as shown.

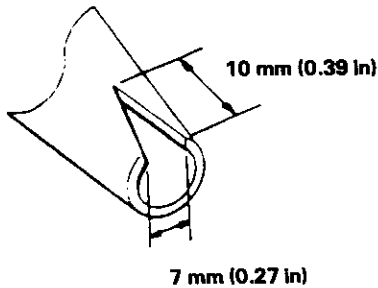

12. Pack adhesive into the cartridge without air pockets to ensure continuous delivery. Put the cartridge in a caulking gun and run a bead of adhesive around the edge of the windshield as shown.

NOTE:

Apply the adhesive within 30 minutes after applying the glass primer.

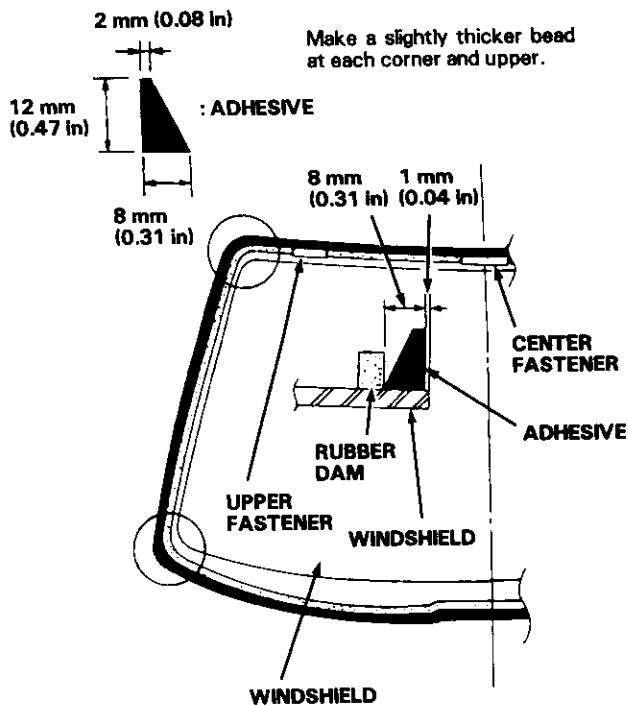

13. Use suction cups to hold the windshield over the opening, align it with the alignment marks made in step 7 and set it down on the adhesive. Lightly push on the windshield until its edge is fully seated on the adhesive all the way around.

NOTE:

- Do not close or open the doors until adhesive is dry.
- Make sure the fasteners are fastened correctly.

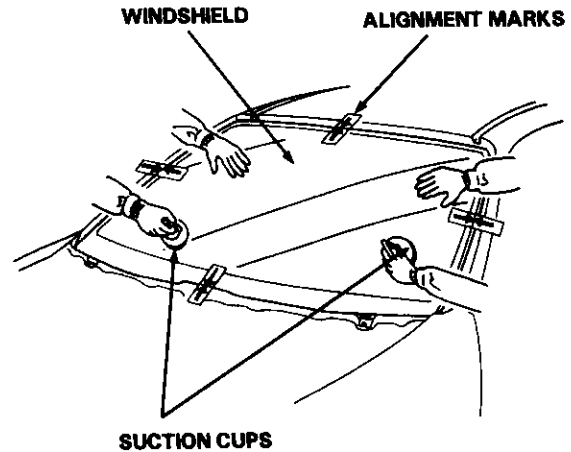

14. Install the clips on the windshield molding.

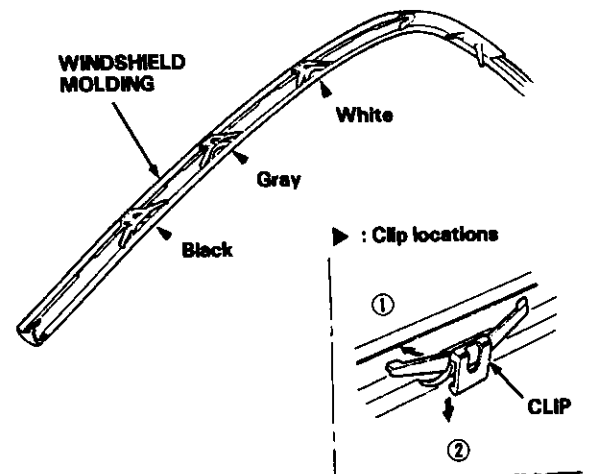



15. Scrape or wipe the excess adhesive off with a putty knife or towel.

NOTE:

To remove adhesive from a painted surface or the windshield, wipe with a soft shop towel dampened with alcohol.

16. Install the windshield molding.

NOTE:

- When installing, make sure there are no twists in the molding.
- Install the windshield molding by starting at the upper corner.
- Glue the upper section with the adhesive.

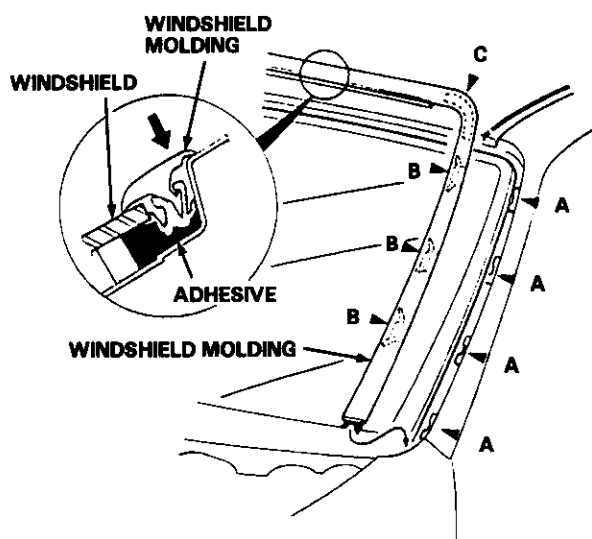

► : Clip, retainer locations

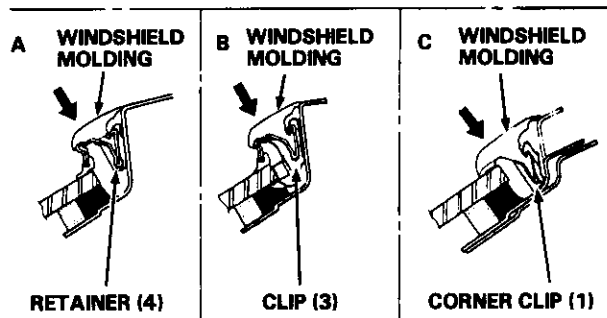

17. Let the adhesive dry for at least one hour, then spray water over the windshield and check for leaks. Mark leaking areas and let the windshield dry, then seal with sealant.

NOTE:

- Let the car stand for at least four hours after windshield installation. If the car has to be used within the first four hours, it must be driven slowly.
- Keep the windshield dry for the first hour after installation.
- Check that the ends of the windshield molding are set under the air scoop.

18. Reassemble all removed parts.

NOTE:

Install the rearview mirror after the adhesive has dried thoroughly.

Rear Window

Removal

CAUTION:

- Wear gloves to remove and install the rear window.
- Do not damage the defroster grid lines.

1. To remove the rear window, first remove:
 - Trunk lid (see page 20-64)
 - Rear shelf (see page 20-37)
 - Rear pillar trim panel (see page 20-37)
2. Disconnect the defroster leads, and remove their holders.

NOTE:

Avoid scratching the rear window with the cutter blade.

3. Remove the molding holders, then remove the lower molding.

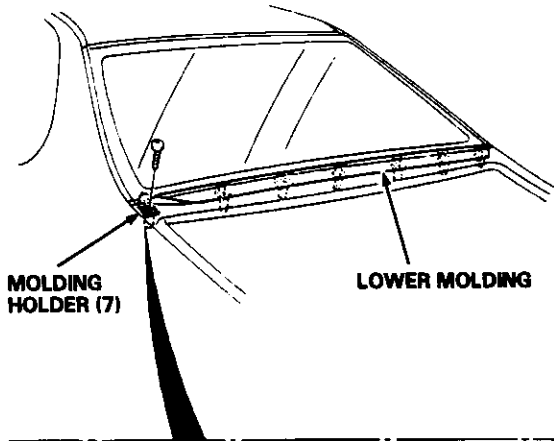

Molding holder removal:

- 1) Remove or loosen the screw.
- 2) Place the screw in the screw grommet again (do not screw it in) and press it down.
- 3) Pull the screw with the molding holder out of the body.

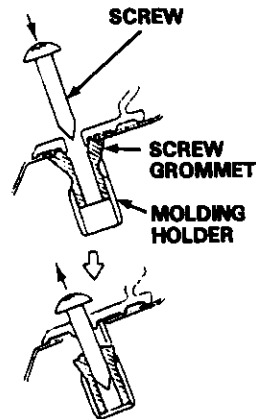

4. Peel off the rear window molding.

NOTE:

- When the rear window molding removal is difficult, cut the rear window molding with a knife.
- If necessary, remove the screw, then replace the glass brackets.

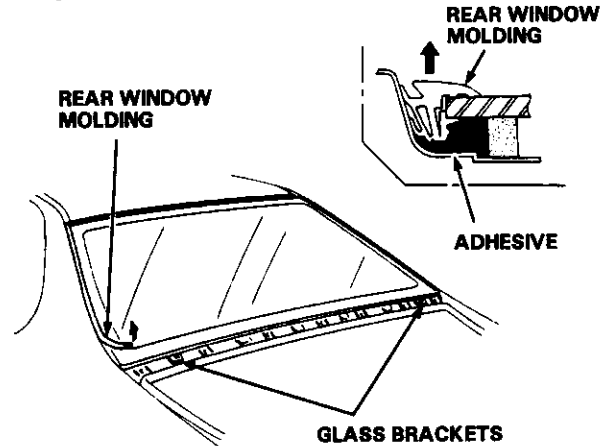

5. Remove the rear headliner (see page 20-36).

CAUTION:

Take care not to bend the headliner excessively.

6. Apply protective tape to along the edge of the body as shown. Using an awl, make a hole through the rubber dam and adhesive from inside the car. Push piano wire through the hole and wrap each end around a piece of wood.

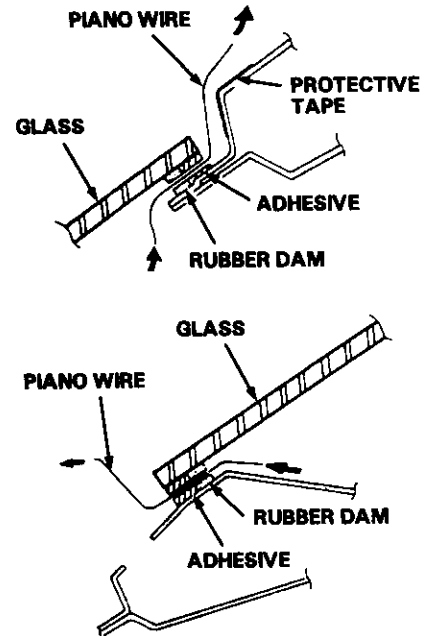



7. With a helper on the outside, pull the piano wire back and forth in a sawing motion and carefully cut through the adhesive around the entire rear window.

CAUTION:

Hold the piano wire as close to the rear window as possible to prevent damage to the body.

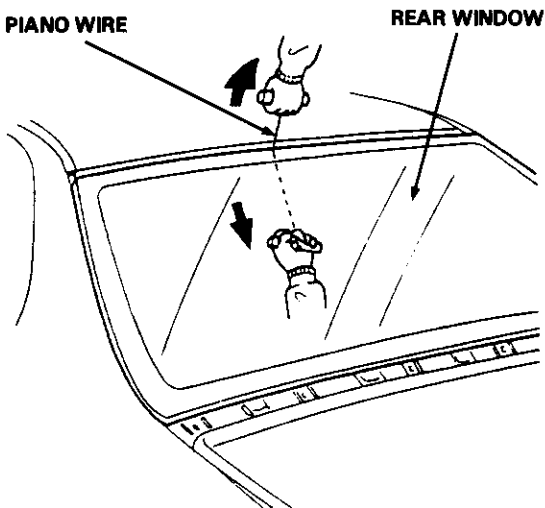

8. Carefully remove the rear window.

Installation

1. Scrape the old adhesive smooth with a knife, to a thickness of about 2 mm (0.08 in) on the bonding surface around the entire rear window opening flange.

NOTE:

- Do not scrape down to the painted surface of the body; damaged paint will interfere with proper bonding.
- Remove the rubber dam and fasteners from the body.
- Mask off surrounding surfaces before applying primer.

2. Clean the body bonding surface with a sponge dampened in alcohol.

NOTE:

After cleaning, keep oil, grease or water from getting on the surface.

3. If the old rear window is to be reinstalled, use a putty knife to scrape off all traces of old adhesive, then clean the rear window surface with alcohol where new adhesive is to be applied.

NOTE:

Make sure the bonding surface is kept free of water, oil and grease.

CAUTION:

Avoid setting the rear window on its edges; small chips may later develop into cracks.

NOTE:

Clean the shadowed area.

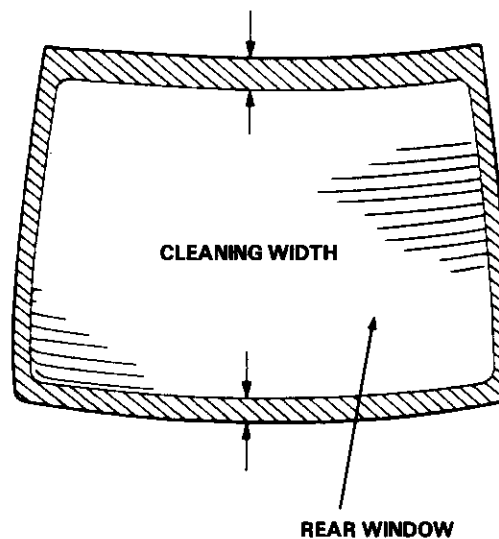

(cont'd)

Rear Window

Installation (cont'd)

4. Glue the rubber dams to the inside face of the rear window as shown, to contain the adhesive during installation.

NOTE:

Be careful not to touch the rear window where adhesive will be applied.

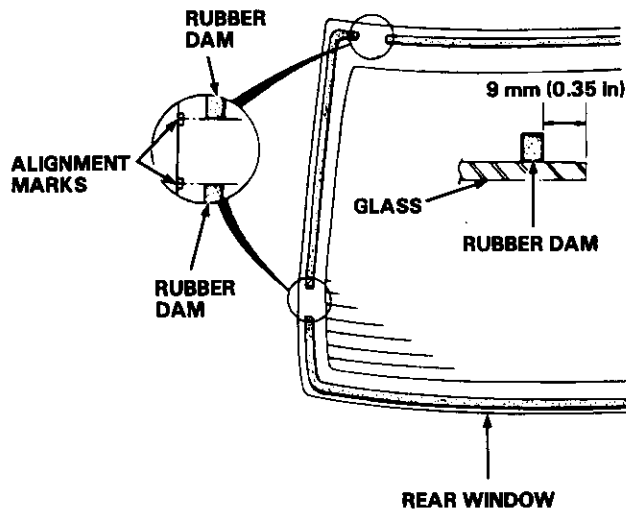

5. Glue the side and upper fasteners to the inside face of rear window as shown.

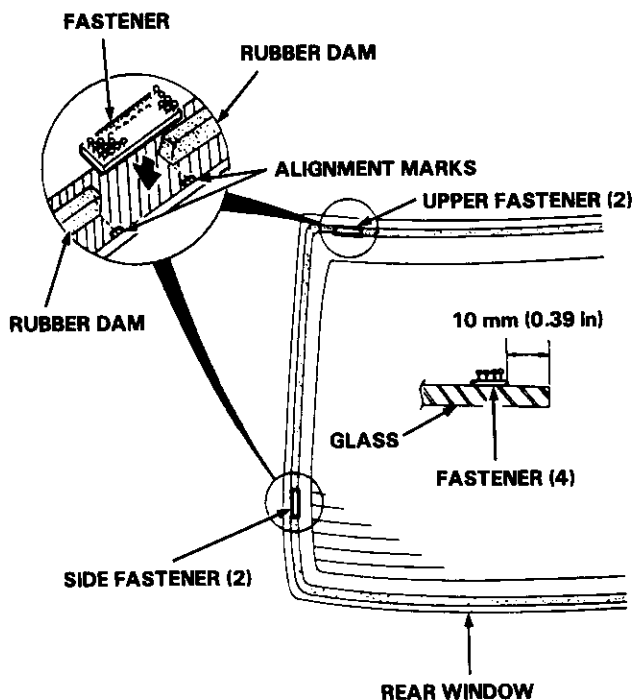

6. Install the glass brackets and fasteners to the body as shown.

NOTE:

Do not tighten the glass bracket mounting screws.

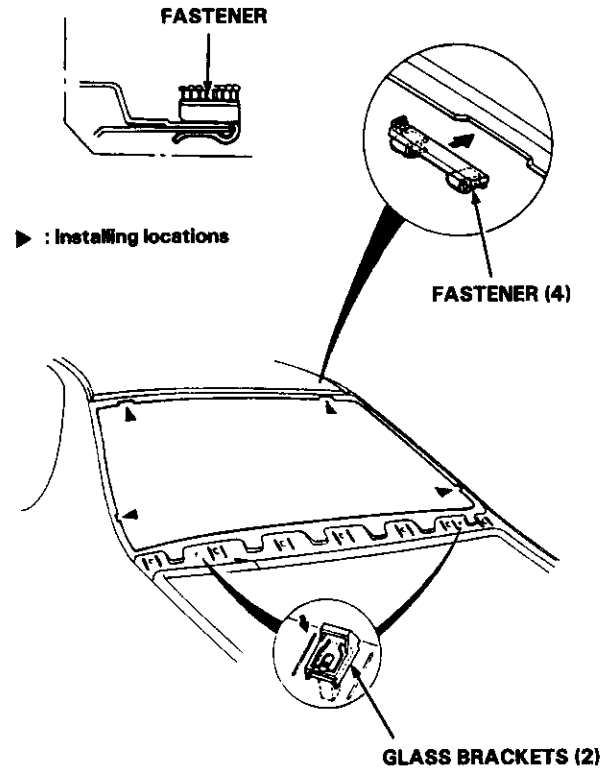

7. Set the rear window upright on the glass brackets, then center it in the opening. Make alignment marks across the rear window and body with a grease pencil at the four points shown.

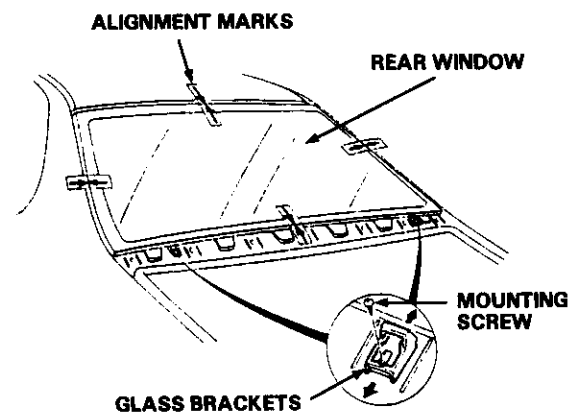

NOTE:

Adjust the brackets to center the rear window in the opening, then tighten the mounting screws.



- With a sponge, apply a light coat of glass primer around the edge of the rear window as shown, then lightly wipe it off with gauze or cheesecloth.

NOTE:

- Do not apply body primer to the rear window, and do not get body and glass primer sponges mixed up.
- Never touch the primed surfaces with your hands. If you do, the adhesive may not bond to the rear window properly, causing a leak after the rear window is installed.
- Keep water, dust, and abrasive materials away from the primed surface.

//// : Apply glass primer here.

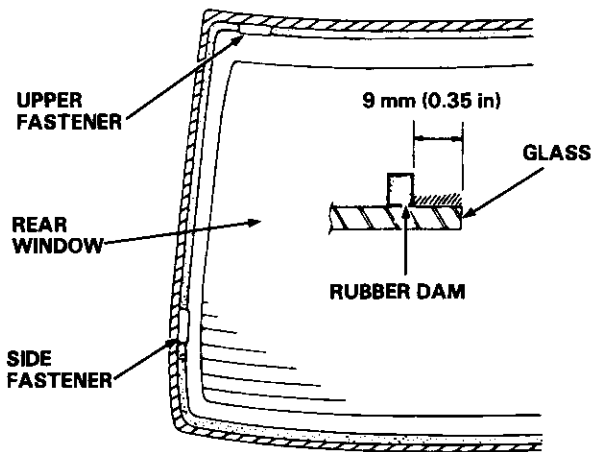

- With a sponge, apply a light coat of body primer to the original adhesive remaining around the rear window opening flange. The rear window should be installed 10 minutes after you apply the body primer.

NOTE:

- Do not apply glass primer to the body, and be careful not to mix up glass and body primer sponges.
- Never touch the primed surfaces with your hands.

//// : Apply body primer here.

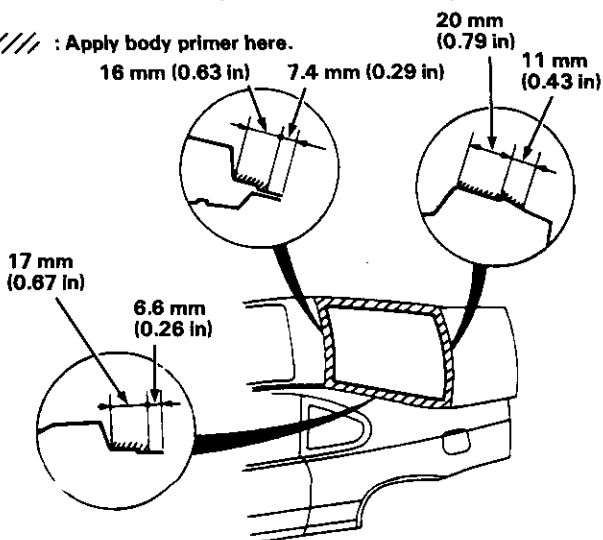

- Thoroughly mix the adhesive and hardener together on a glass or metal plate with a putty knife. Follow the instructions that came with the adhesive.

NOTE:

Clean a glass or metal plate with a sponge and alcohol before mixing.

- Before filling a cartridge, cut the end of the nozzle as shown.

Cut nozzle end as shown.

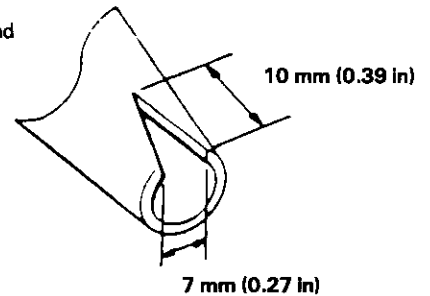

- Pack adhesive into the cartridge without air pockets to ensure continuous delivery. Put the cartridge in a caulking gun and run a bead of adhesive around the edge of the rear window as shown.

NOTE:

Apply the adhesive within 30 minutes after applying the glass primer.

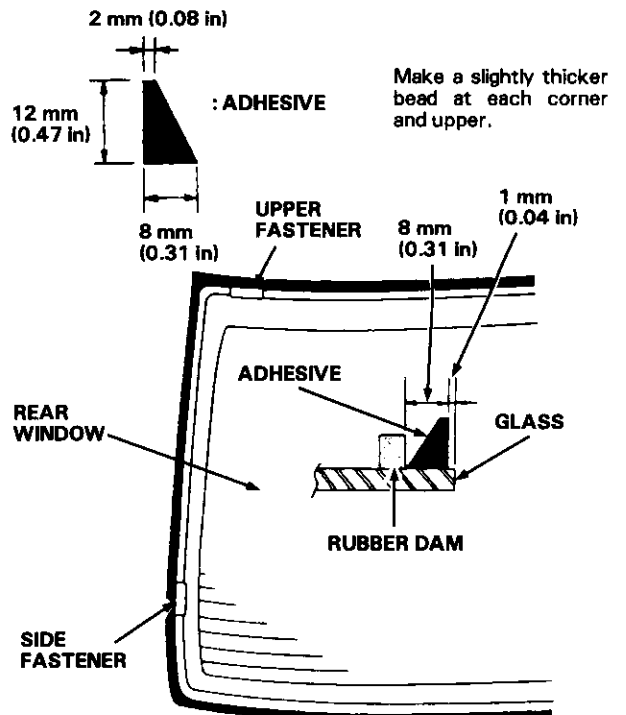

(cont'd)

Rear Window

Installation (cont'd)

13. Use suction cups to hold the rear window over the opening, align it with the alignment marks made in step 7 and set it down on the adhesive. Lightly push on the rear window until its edges are fully seated on the adhesive all the way around.

NOTE:

- Do not close or open the doors until adhesive is dry.
- Make sure the fasteners are fastened correctly.

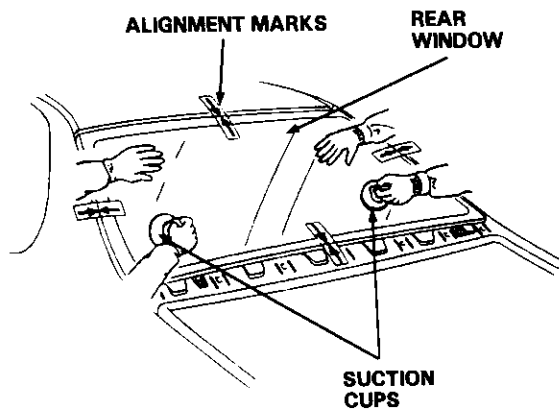

14. Scrape or wipe excess adhesive off with a putty knife or towel.

NOTE:

To remove adhesive from a painted surface or the rear window, use a soft shop towel dampened with alcohol.

15. Install the rear window molding.

NOTE:

- When installing, make sure there are no twists in the rear window molding.
- First install the upper section, then install the each side.
- Glue the upper section with the adhesive.

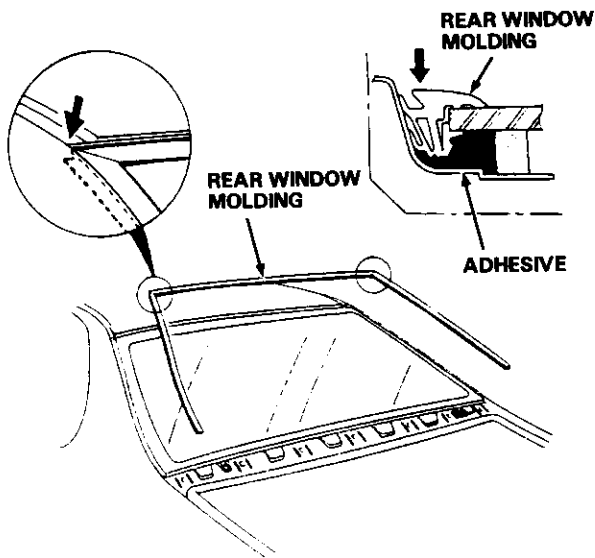

16. Install the molding holder on the lower molding.

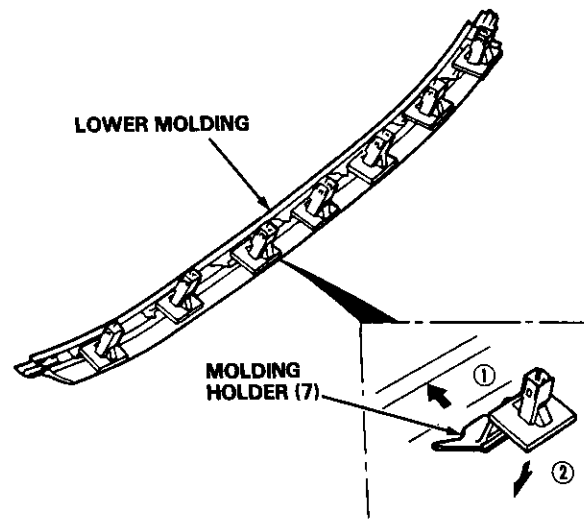

17. Install the lower molding, then tighten the mounting screws.

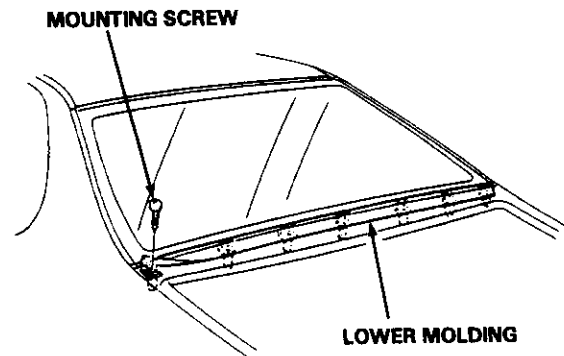

18. Let the adhesive dry for at least one hour, then spray water over the rear window and check for leaks. Mark leaking areas and let the rear window dry, then seal with sealant.

NOTE:

Let the car stand for at least four hours after rear window installation. If the car has to be used within the first four hours, it must be driven slowly.

19. Reassemble all removed parts.



Quarter Glass

Removal

CAUTION:

- Wear gloves to remove and install the glass.
- Use seat covers to avoid damaging any surfaces.

NOTE:

Replace the quarter glass with new one when removing it.

1. To remove the quarter glass, first remove the:
 - Rear pillar trim panel (see page 20-37)
 - Quarter trim (see page 20-37)
 - Quarter trim panel (see page 20-37)
2. Use a knife to cut through the adhesive from inside the car, all the way around.

NOTE:

Take care not to damage the quarter glass and body.

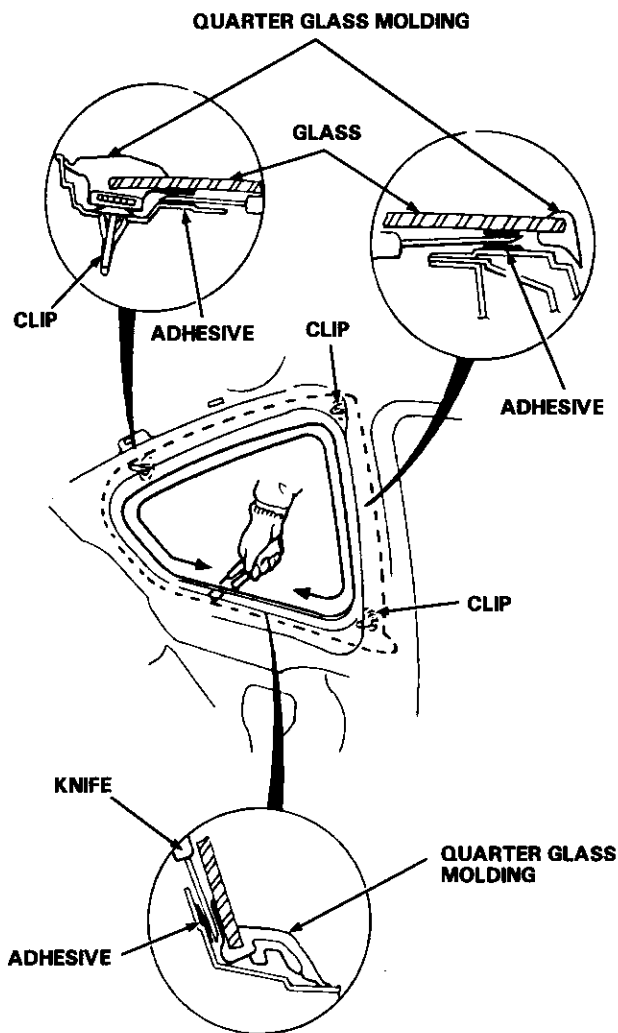

3. Remove the quarter glass.

Installation

1. Scrape the old adhesive smooth with a knife, to a thickness of about 2 mm (0.08 in) on the bonding surface around the entire quarter glass opening flange.

NOTE:

- Do not scrape down to the painted surface of the body; damaged paint will interfere with proper bonding.
- Mask off surrounding surfaces before applying primer.

2. Clean the body bonding surface with a sponge dampened in alcohol.

NOTE:

After cleaning, keep oil, grease or water from getting on the surface.

3. Clean the new quarter glass surface with alcohol where adhesive is to be applied.

NOTE:

Make sure the bonding surface is kept free of water, oil and grease.

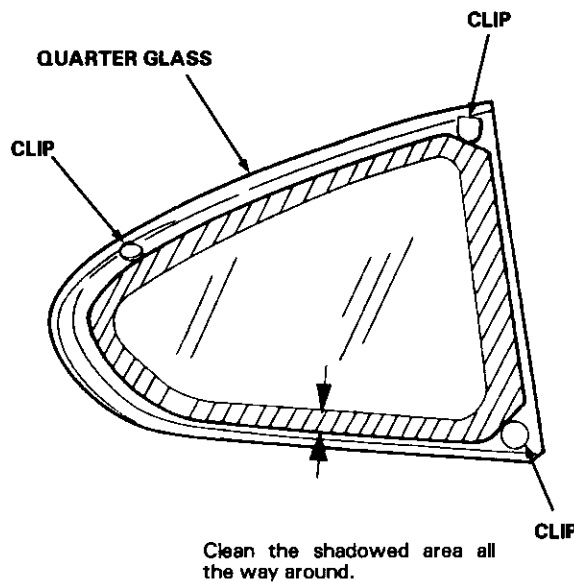

(cont'd)

Quarter Glass

Installation (cont'd)

4. With a sponge, apply a light coat of glass primer to the inside face of the quarter glass as shown, then lightly wipe it off with gauze or cheesecloth.

NOTE:

- Do not apply body primer to the quarter glass, and do not get body and glass primer sponges mixed up.
- Never touch the primed surfaces with your hands. If you do, the adhesive may not bond to the quarter glass properly, causing a leak after the quarter glass is installed.
- Keep water, dust, and abrasive materials away from the primed surface.

////// : Apply glass primer here.

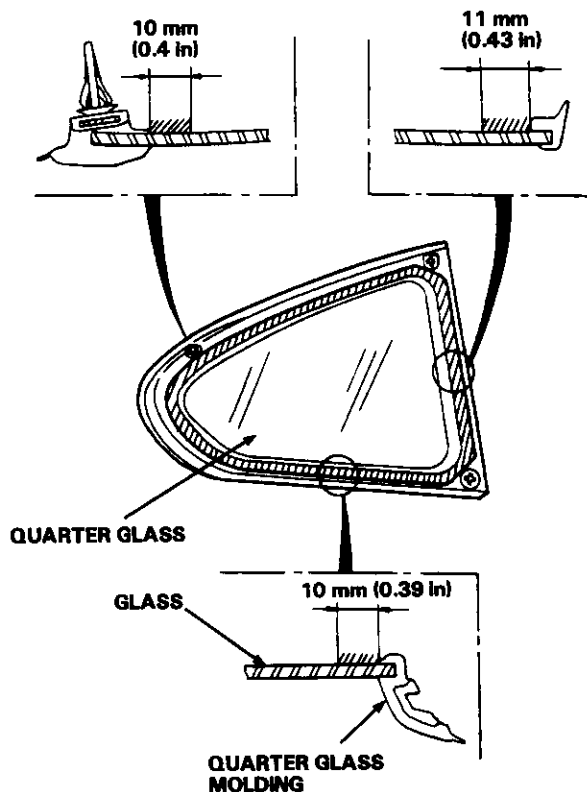

5. With a sponge, apply a light coat of body primer to the original adhesive remaining around the quarter glass opening flange. The quarter glass should be installed 10 minutes after you apply the body primer.

NOTE:

- Do not apply glass primer to the body, and be careful not to mix up glass and body primer sponges.
- Never touch the primed surfaces with your hands.

////// : Apply body primer here.

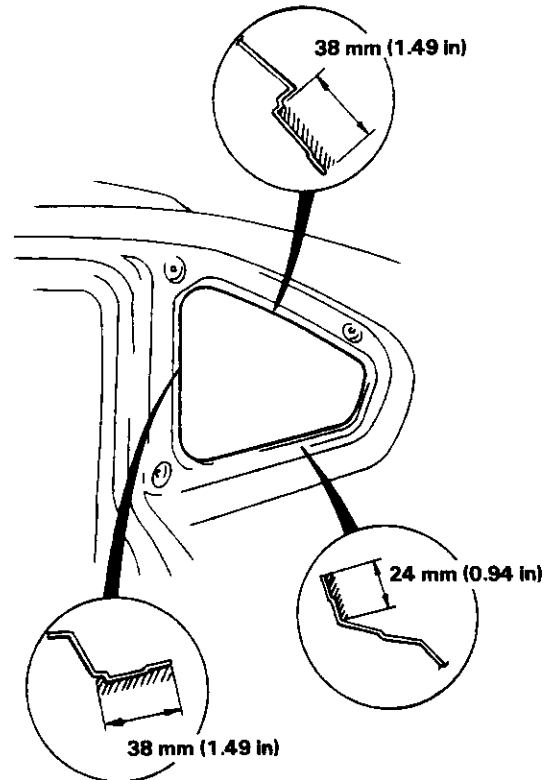

6. Thoroughly mix the adhesive and hardener together on a glass or metal plate with a putty knife.

NOTE:

- Clean a glass or metal plate with a sponge and alcohol before mixing.
- Follow the instructions that came with the adhesive.

7. Before filling a cartridge, cut the end of the nozzle as shown.

Cut nozzle end as shown.

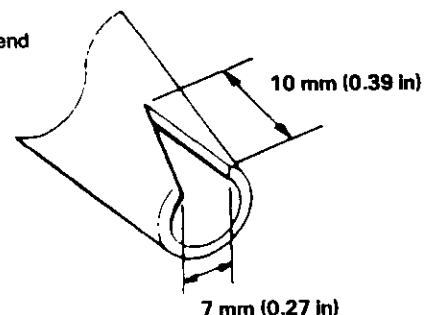



8. Pack adhesive into the cartridge without air pockets to ensure continuous delivery. Put the cartridge in a caulking gun and run a bead of adhesive around the edge of the quarter glass as shown.

NOTE:

Apply the adhesive within 30 minutes after applying the glass primer.

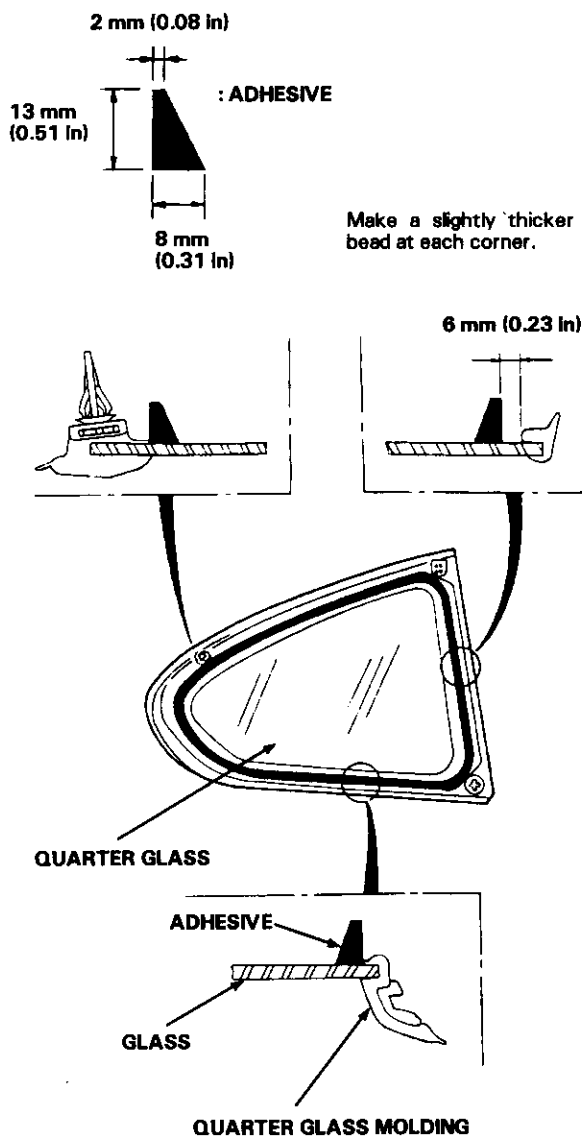

9. Use suction cups to hold the quarter glass over the opening, align it with the clip setting points and set it down on the adhesive. Lightly push on the quarter glass until its edges are fully seated on the adhesive all the way around.

NOTE:

Do not open or close the doors until the adhesive is dry.

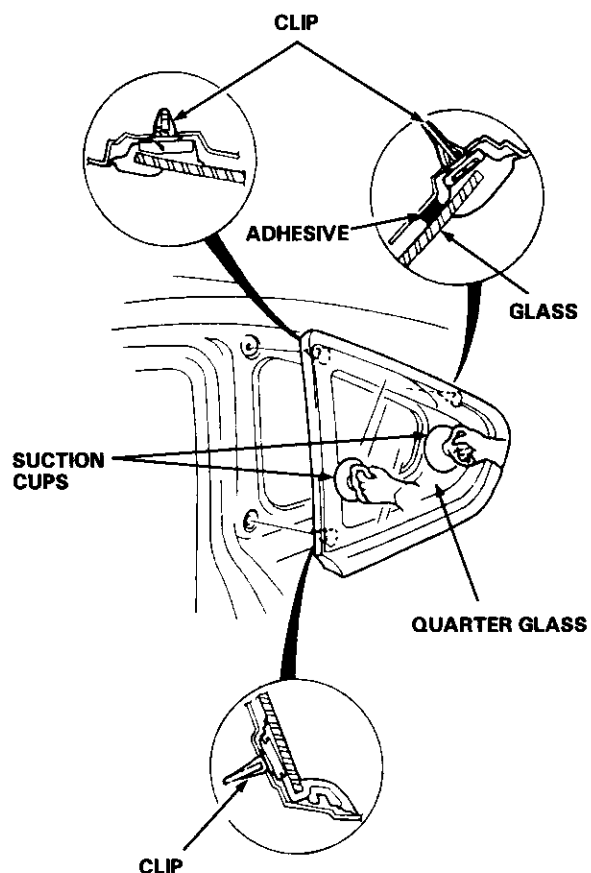

10. Scrape or wipe the excess adhesive off with a putty knife or towel.

NOTE:

Use a soft shop towel dampened with alcohol to remove adhesive from a painted surface or quarter glass.

11. After the adhesive is dry, spray water over the quarter glass and check for leaks. Mark leaking areas and let the quarter glass dry, then seal with sealant.

NOTE:

Let the car stand for at least four hours after quarter glass installation. If the car has to be used within the first four hours, it must be driven slowly.

12. Reinstall all remaining removed parts.

Sunroof

Index

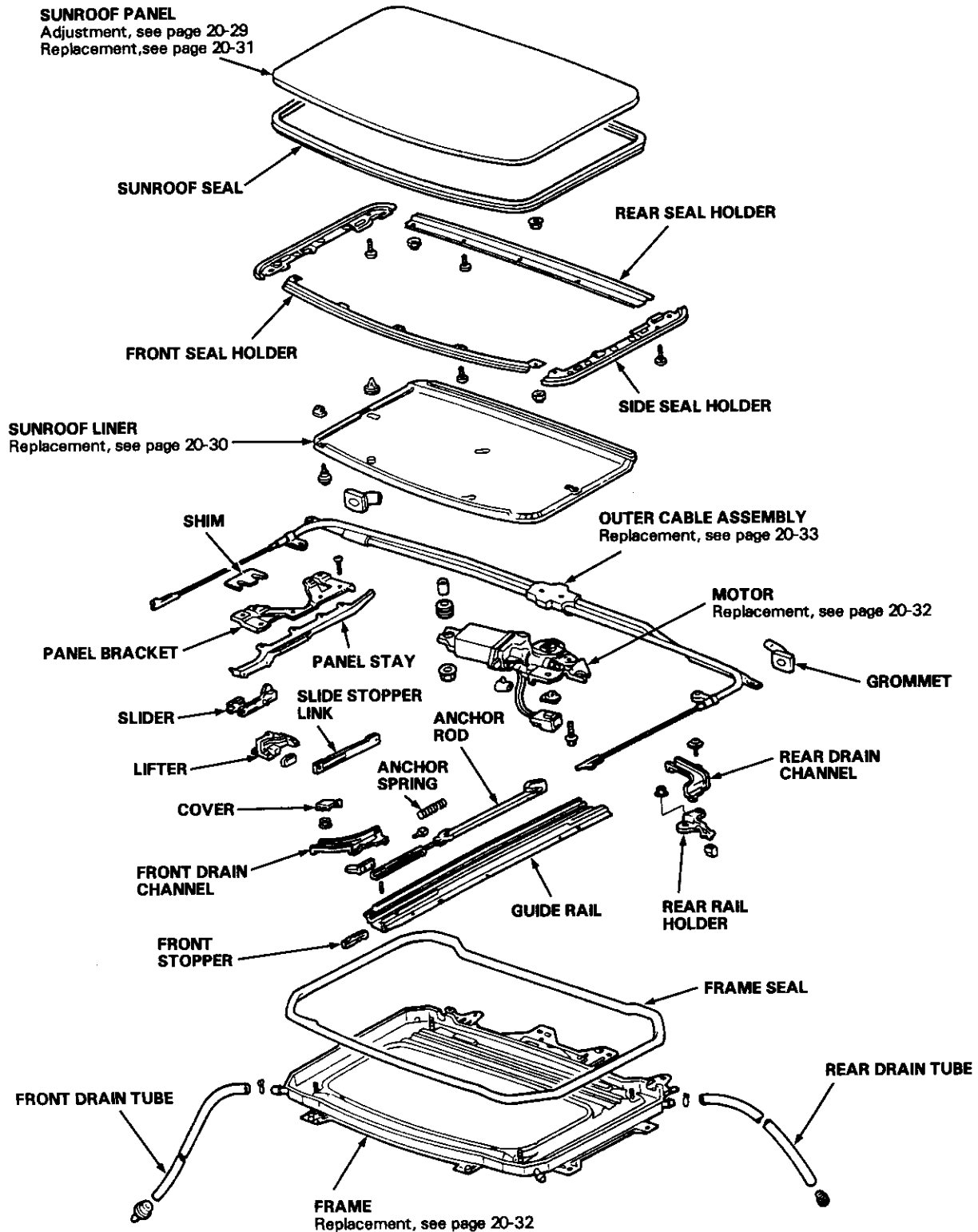



Troubleshooting

Symptom	Probable Cause
Water leaks	<ol style="list-style-type: none"> 1. Clogged drain tube. 2. Gap between sunroof seal and roof panel. 3. Defective or improperly installed sunroof seal. 4. Gap between frame seal and roof panel.
Wind noise	<ol style="list-style-type: none"> 1. Excessive clearance between sunroof seal and roof panel.
Motor noise	<ol style="list-style-type: none"> 1. Loose motor. 2. Worn gear or bearing. 3. Outer cable deformed.
Sunroof panel does not move, but motor turns	<ol style="list-style-type: none"> 1. Clutch out of adjustment. 2. Foreign matter stuck between guide rail and slider. 3. Inner cable loose. 4. Outer cable not attached properly.
Sunroof panel does not move and motor does not turn (sunroof panel can be moved with sunroof wrench)	<ol style="list-style-type: none"> 1. Blown fuse. 2. Faulty switch. 3. Battery run down. 4. Defective motor. 5. Faulty relay.

Sunroof Panel Height Adjustment

Roof panel should be even with the sunroof seal to within 1.9 ± 0.5 mm (0.07 ± 0.02 in) all the way around. If not, tilt the sunroof panel fully, and:

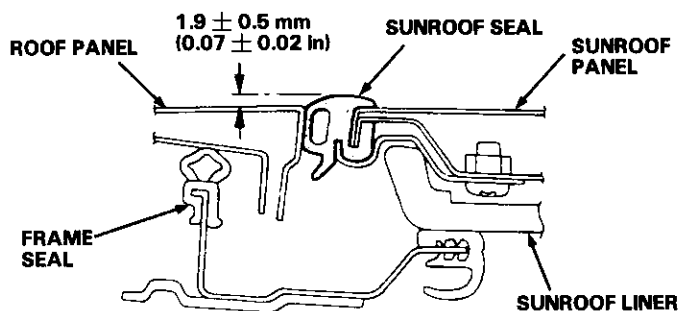

1. Remove the sunroof liner (see page 20-30).
2. Loosen the sunroof panel mounting nuts and install shims between sunroof panel and panel bracket as shown.

Shim thickness: 1.0 mm (0.04 in)
Adjustment: max. 2.0 mm (0.08 in)

3. Repeat on opposite side if necessary.

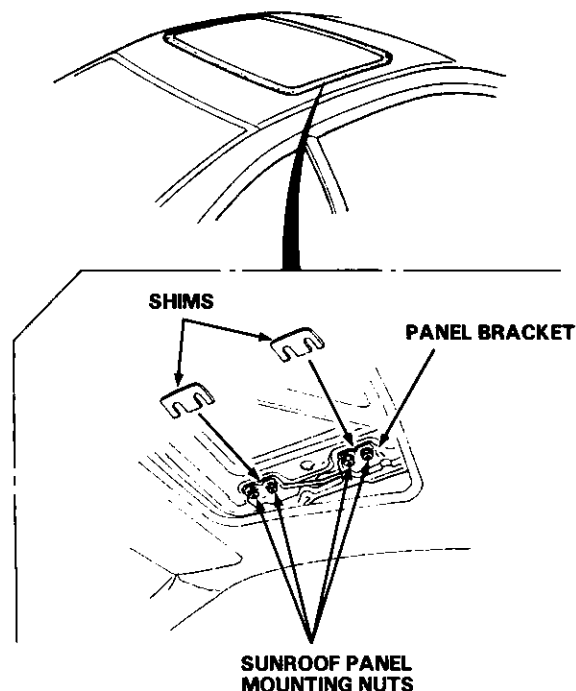

Sunroof

Rear Edge Closing Adjustment

Open the sunroof panel about a foot, then close it to check where rear edge begins to rise. If it rises too soon and seats too tightly against the roof panel, or too late and does not seat tightly enough, adjust it.

1. Remove the sunroof liner, then remove the sunroof panel.
2. Check that the position of the lifter is the same on each side.

NOTE:

If the position differs from side to side, remove the motor (see page 20-32), then adjust the position of the lifter on each side.

3. Loosen the mounting screws. Align the panel bracket to the same position on each side.

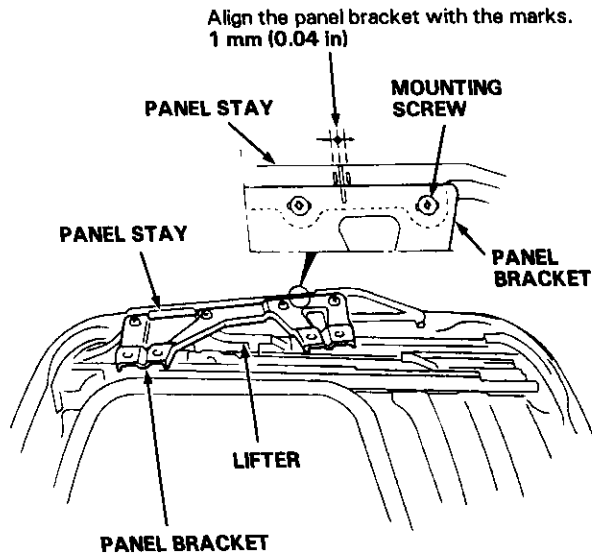

4. Install the sunroof panel. Close the sunroof panel, then check the alignment between the roof panel and sunroof panel.

NOTE:

Adjust the sunroof panel right and left by using the panel bracket mounting holes.

5. With the sunroof panel closed fully, check for water leaks.

NOTE:

Do not use high pressure water.

Sunroof Liner and Sunroof Panel Replacement

1. Remove the front of the roof trim.
2. Align the location (A) position of the frame to the mounting screw.

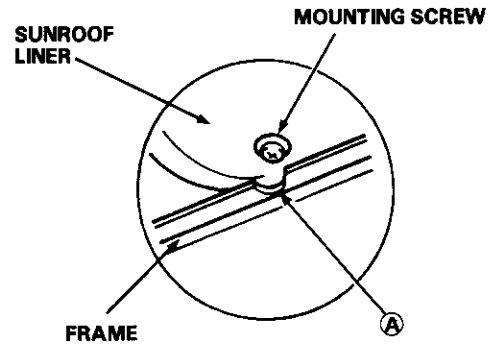

3. Remove the mounting screws and clips, then slide the sunroof liner slightly forward.

NOTE:

Take care not to scratch the sunroof liner.

▶ Clip locations

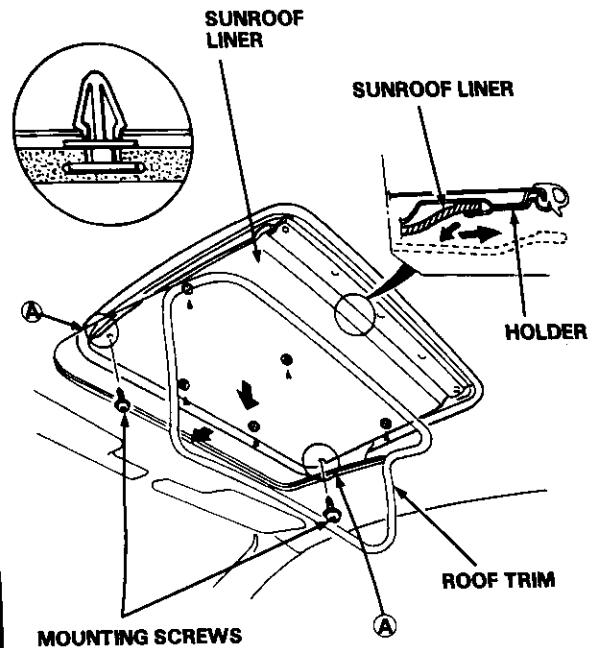

4. Slide the sunroof liner backward, then remove it.

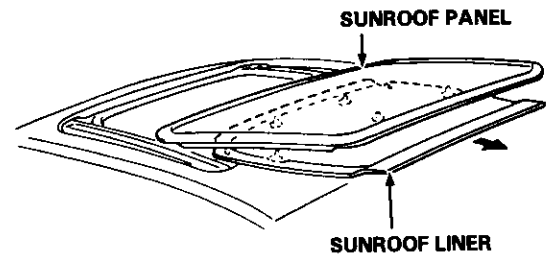



- Remove the mounting nuts from the panel brackets on both sides, then remove the sunroof panel by lifting up.

NOTE:
Do not damage the roof panel.

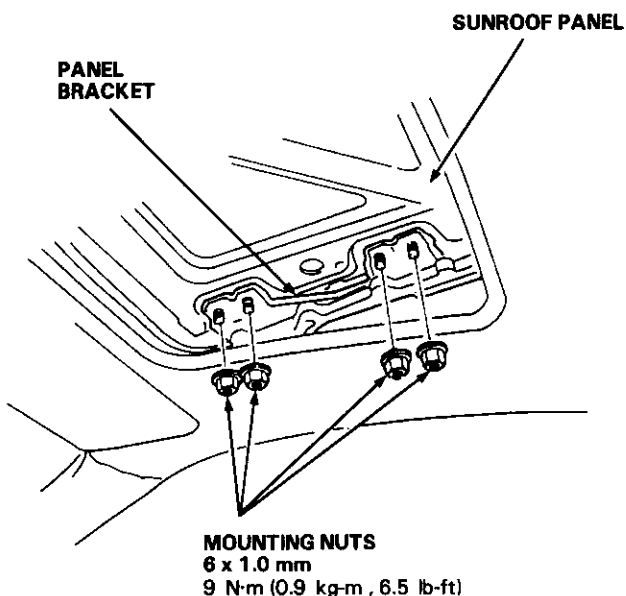

- Installation is the reverse of the removal procedure.

NOTE:

- Before installing the sunroof liner, close the sunroof panel fully, then check for closing alignment. If necessary, adjust the sunroof panel alignment (see page 20-30).
- When installing the sunroof liner, make sure the sunroof liner is fastened correctly with the clips and holder.

- Check for water leaks.

NOTE:
Do not use high pressure water.

Sunroof Seal Repair/Installation

If a sunroof seal is leaking, or if it is to be replaced, proceed as follows:

- Remove the sunroof liner (see page 20-30).
- Remove the sunroof panel.
- Remove the seal holder. Carefully peel the seal off the sunroof panel.

► : Screw, nut locations

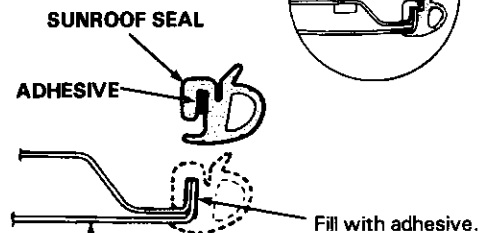
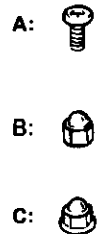
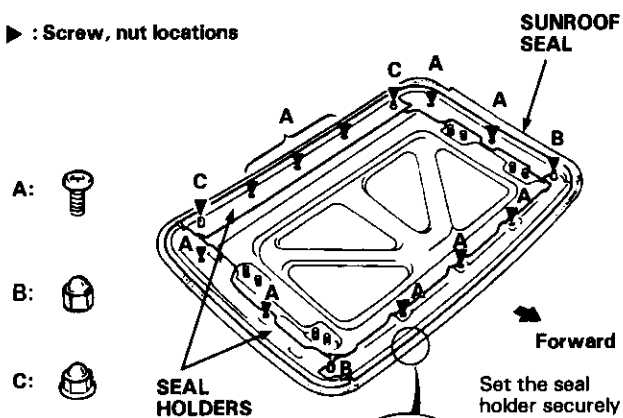

- Clean the sunroof seal attaching surfaces with a clean cloth dampened in alcohol.

NOTE:
After cleaning, keep oil, grease or water from getting on the surface.

- Fill the sunroof seal groove with adhesive. Coat the sunroof seal attaching surfaces of the sunroof panel with the same adhesive.
- Fit the sunroof seal onto the sunroof panel evenly all the way around.
- Wipe off excess adhesive with a clean cloth dampened with alcohol.
- Allow the adhesive to cure for at least four hours after sunroof seal installation and before operating the sunroof panel.
- Check for water leaks.

NOTE:
Do not use high pressure water.

Sunroof

Motor, Drain Tube, and Frame Replacement

CAUTION:

Be careful not to damage the seats or other interior trim.

1. Remove the headliner (see page 20-36).
2. Disconnect the motor connector; remove the clips securing the ceiling light wire harness.

NOTE:

When removing the motor, remove the two mounting bolts and three nuts.

3. Remove the sunroof panel (see page 20-31).
4. Disconnect the drain tubes.
5. Remove the 10 mounting bolts and rear hooks, then remove the frame from the car.

NOTE:

You may require assistance when removing the frame.

DRAIN TUBE

To install, slide the drain tube over the frame nozzle at least 10 mm (0.4 in).

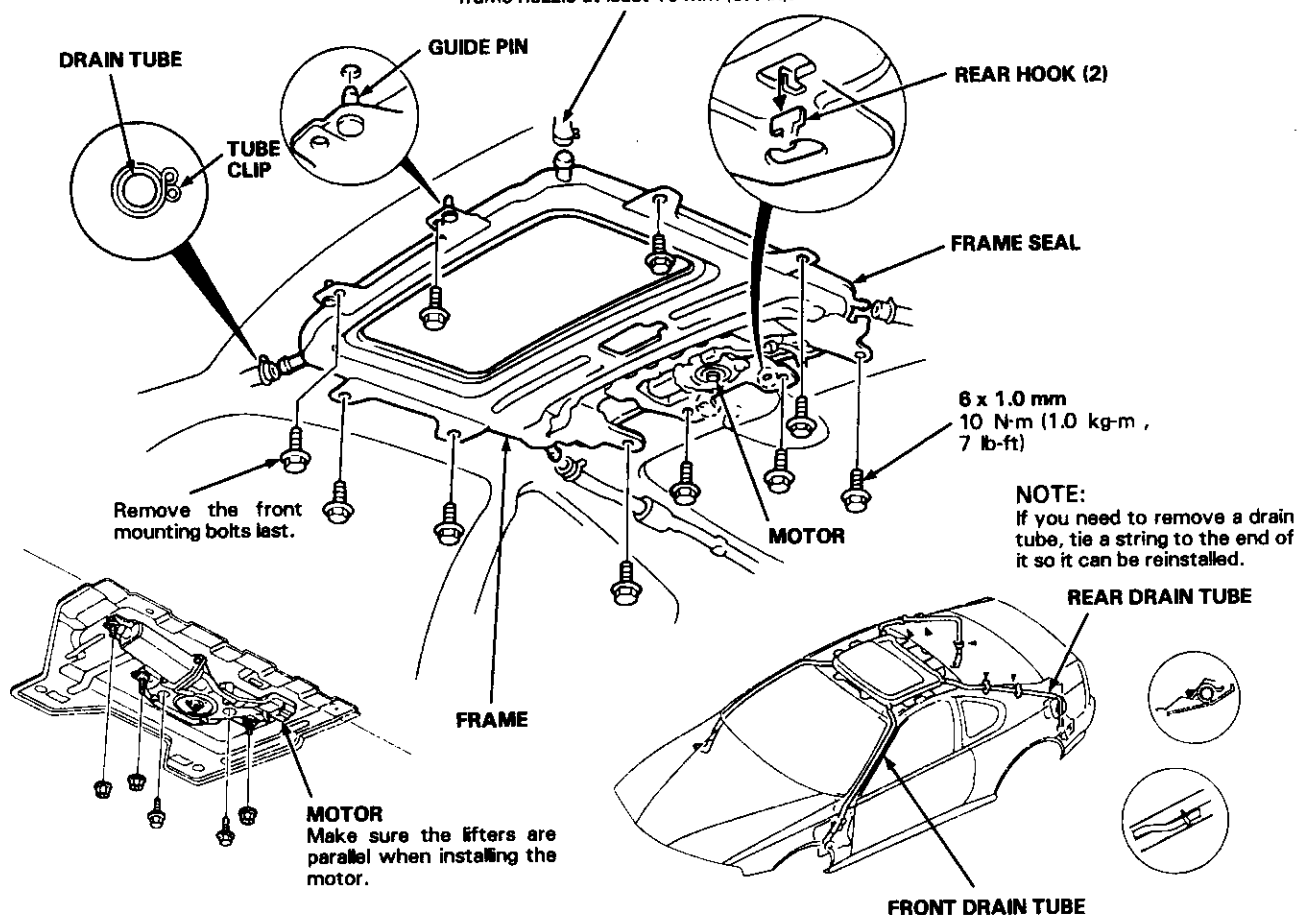

6. To install, insert the frame's rear hooks into the body holes, then install parts in the reverse order of removal.

NOTE:

- Install the tube clips with the ends facing to the side to ease installation of the headliner.
- Clean the surface of frame.
- Check the frame seal.
- Check for water leaks.



Panel Stay/Slider, Lifter and Guide Rails Replacement

1. Remove the frame (see page 20-32).
2. Remove the front drain channel.

6 x 1.0 mm
10 N·m (1.0 kg·m, 7 lb-ft)

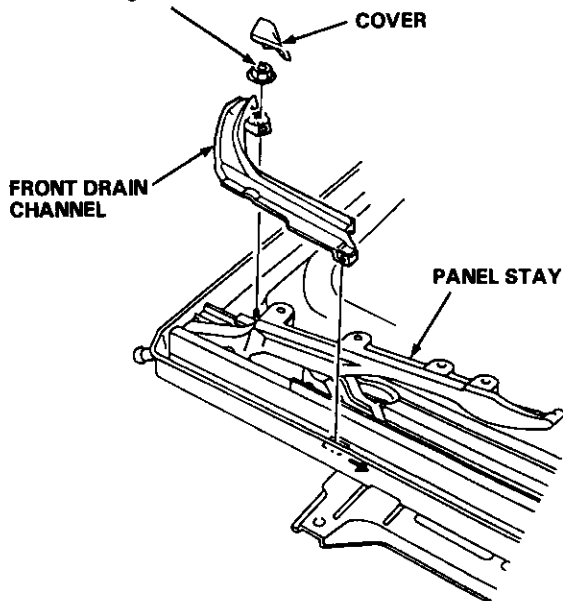

3. Remove the rear drain channel.
4. Remove the rear rail holder.

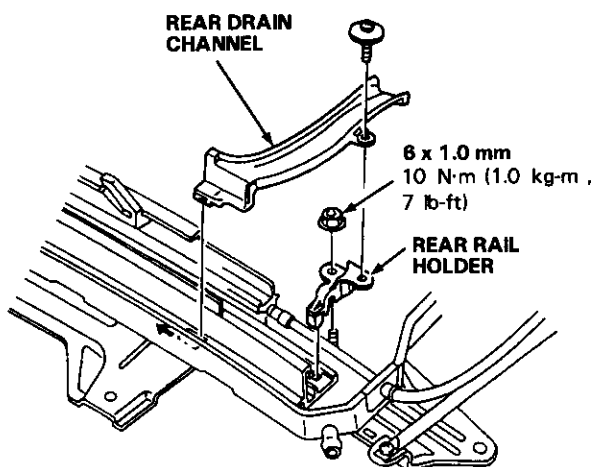

5. Remove the motor (page 20-32).
6. Remove the mounting screws (A), then remove the guide rail. Remove the mounting screw (B), then remove the outer cable assembly.

NOTE:

Take care not to bend the cable pipes.

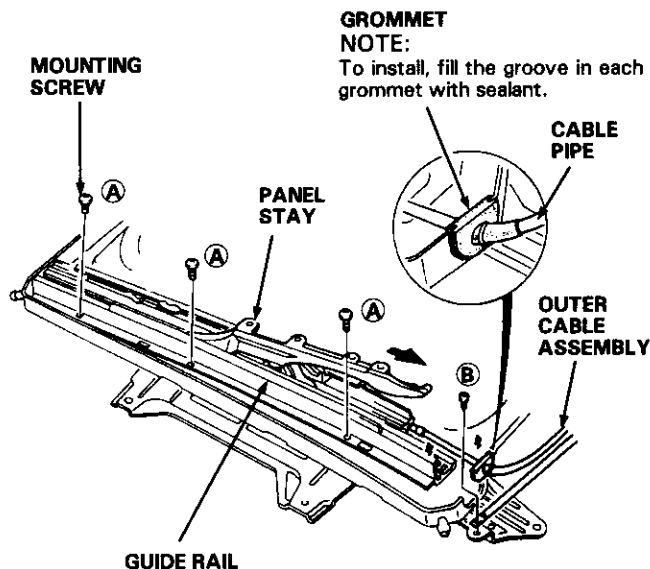

7. Slide the panel stay backward, then remove it from the guide rail.
8. Remove the lifter from the inner cable end, then separate the panel stay, lifter, slide stopper link and slider.

NOTE:

To install, apply multi-purpose grease to the lifter and slide stopper link.

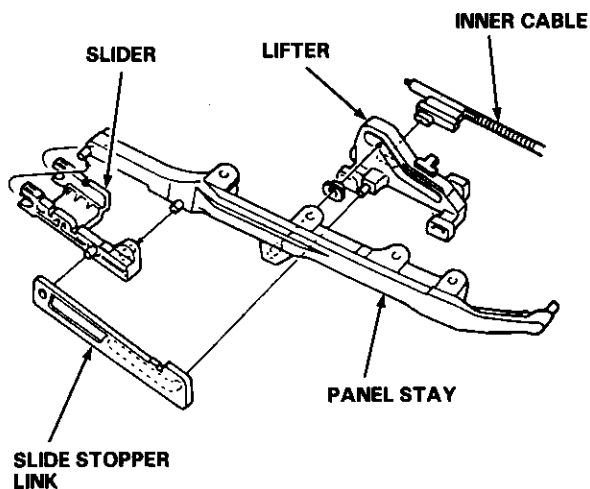

(cont'd)

Sunroof

Panel Stay/Slider, Lifter and Guide Rails Replacement (cont'd)

9. Turn the hook of the anchor rod with a flat tip screwdriver, then remove the anchor rod and anchor spring from the guide rail by sliding it backward.

NOTE:

To install, apply multi-purpose grease to the hook.

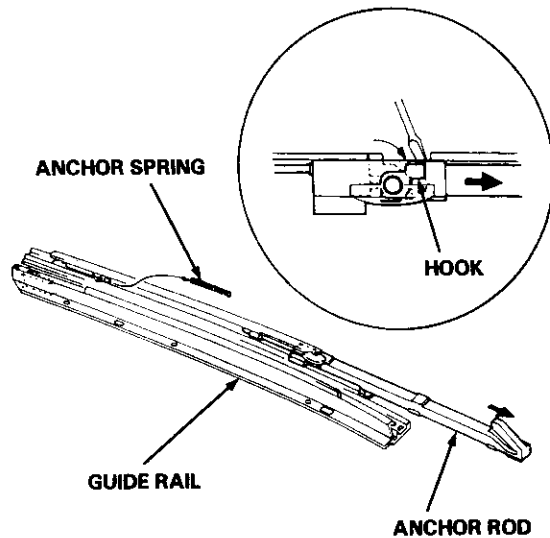

10. Installation is the reverse of the removal procedure.

NOTE:

- Before installing the guide rail, apply the calking to guide rail mount faces of the frame.

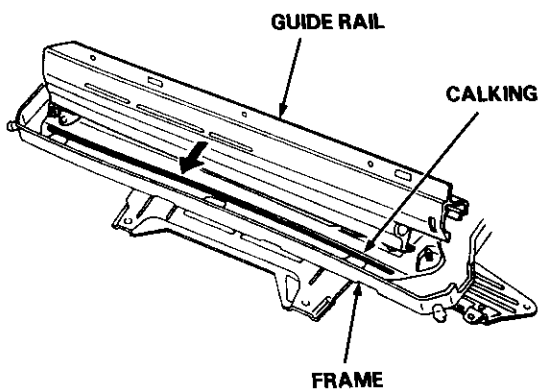

- Damaged parts should be replaced.
- Apply grease to the sliding portion.
- Before installing the motor, adjust the lifter to the same position on each side.

Opening Drag Check (Motor Removed)

Before installing the motor, measure effort required to open sunroof panel using a spring scale as shown.

CAUTION:

When using a spring scale, protect the leading edge of the sunroof panel with a shop towel.

If load is over 10 kg (22 lbs), check side clearance and sunroof panel height adjustment (see page 20-29).

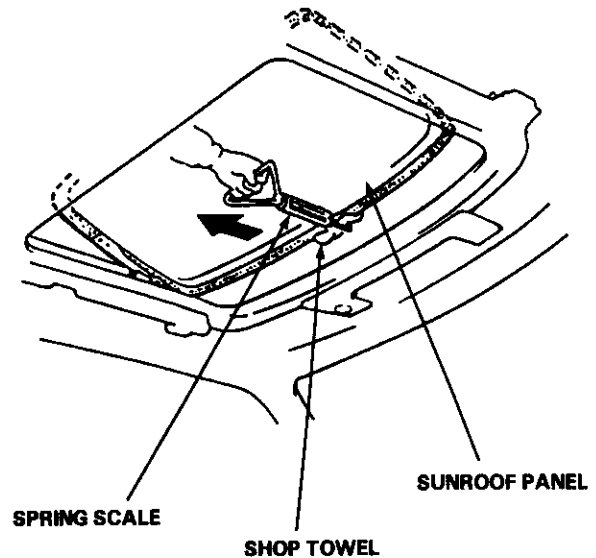



Closing Force Check (Motor Installed)

1. After installing all removed parts, have a helper hold the switch to close the sunroof panel while you measure force required to stop it. Attach a spring scale as shown. Read the force as soon as the sunroof panel stops moving, then immediately release the switch and spring scale.

CAUTION:

When using a spring scale, protect the leading edge of the sunroof panel with a shop towel.

Closing Force: 20—30 kg (44—66 lbs)

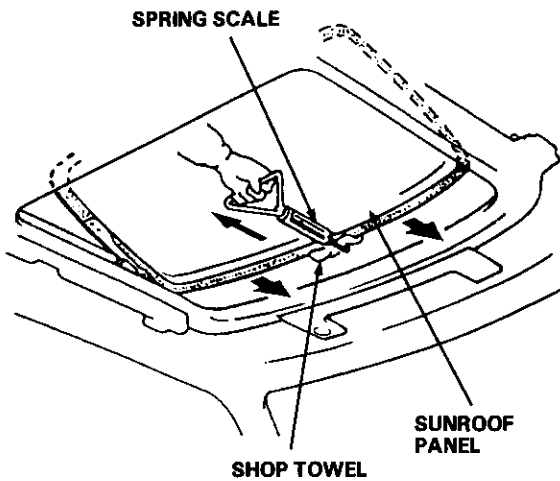

2. If force is not within specification, install a new lock washer, adjust the tension by turning the motor clutch adjusting nut, and bend the lock washer against the motor clutch adjusting nut.

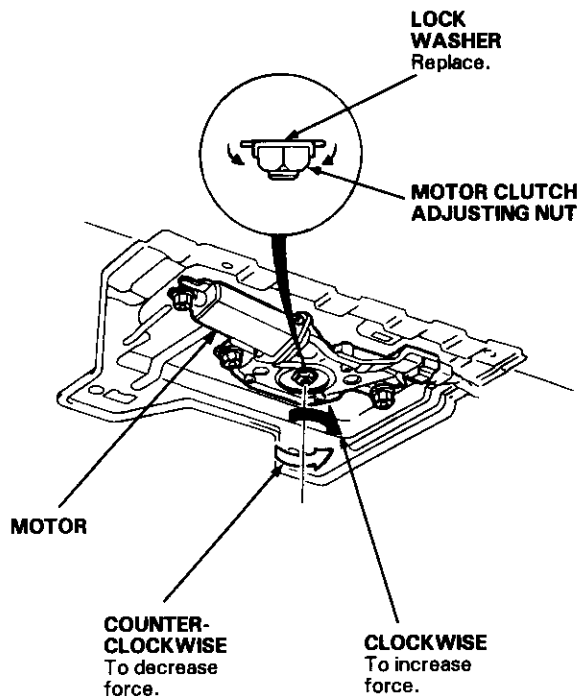

Headliners

Replacement

► : Clip locations

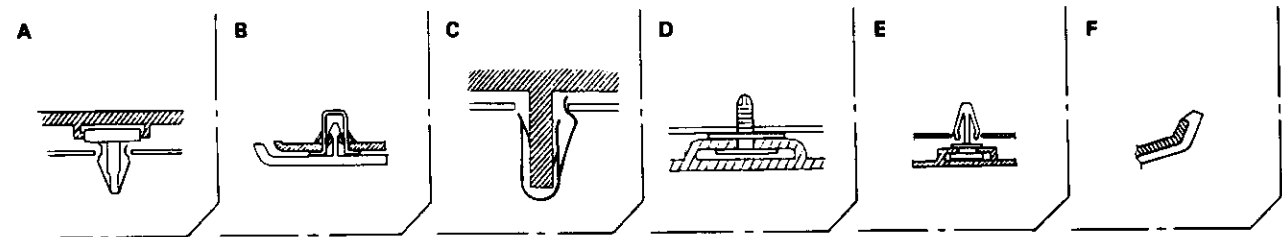

CAUTION:

When prying with a flat tip screwdriver, wrap it with protective tape to prevent damage.

NOTE:

- Remove the front seats (see page 20-38).
- Take care not to bend or scratch the front and rear headliners.
- Keep water away from the front and rear headliners.
- Be careful not to damage the dashboard and other interior trim.

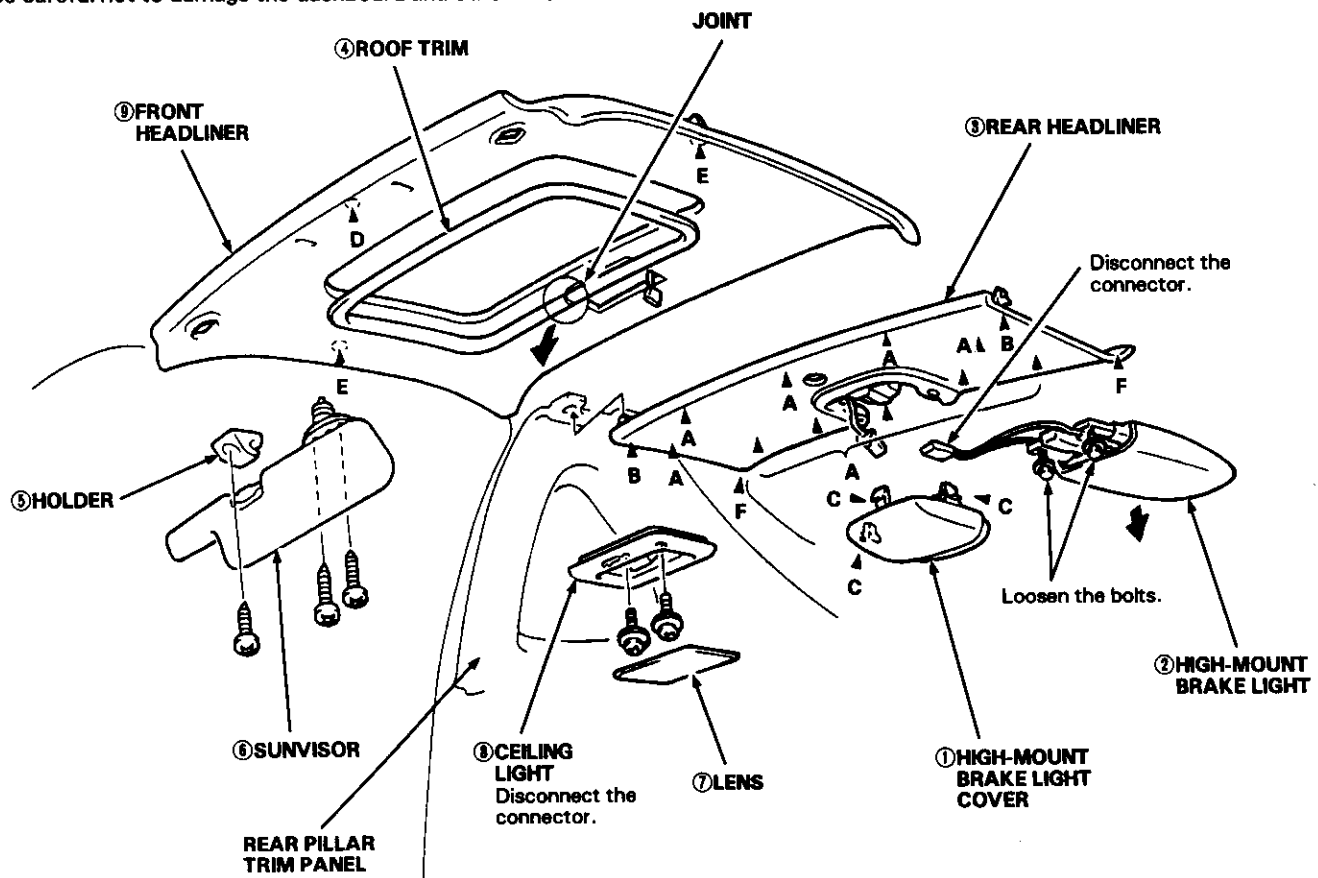

NOTE:

Remove the headliner from the passenger's side door opening.

Installation is the reverse of the removal procedure.

NOTE:

- When installing the front and rear headliners, be careful not to fold or bend it. Also, be careful not to scratch the body.
- Check that both sides of the front and rear headliners are securely attached to the body and rear pillar trim panel.
- When installing the roof trim, install the joint towards the rear.
- If necessary, replace any damaged clips.



Interior Trims

Replacement

► : Clip locations

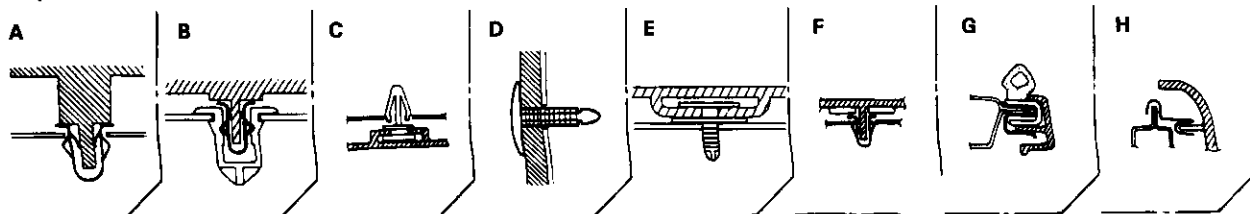

Disassemble in numbered sequence.

CAUTION:

When prying with a flat tip screwdriver, wrap it with protective tape to prevent damage.

NOTE:

Take care not to bend or scratch the trims and panels.

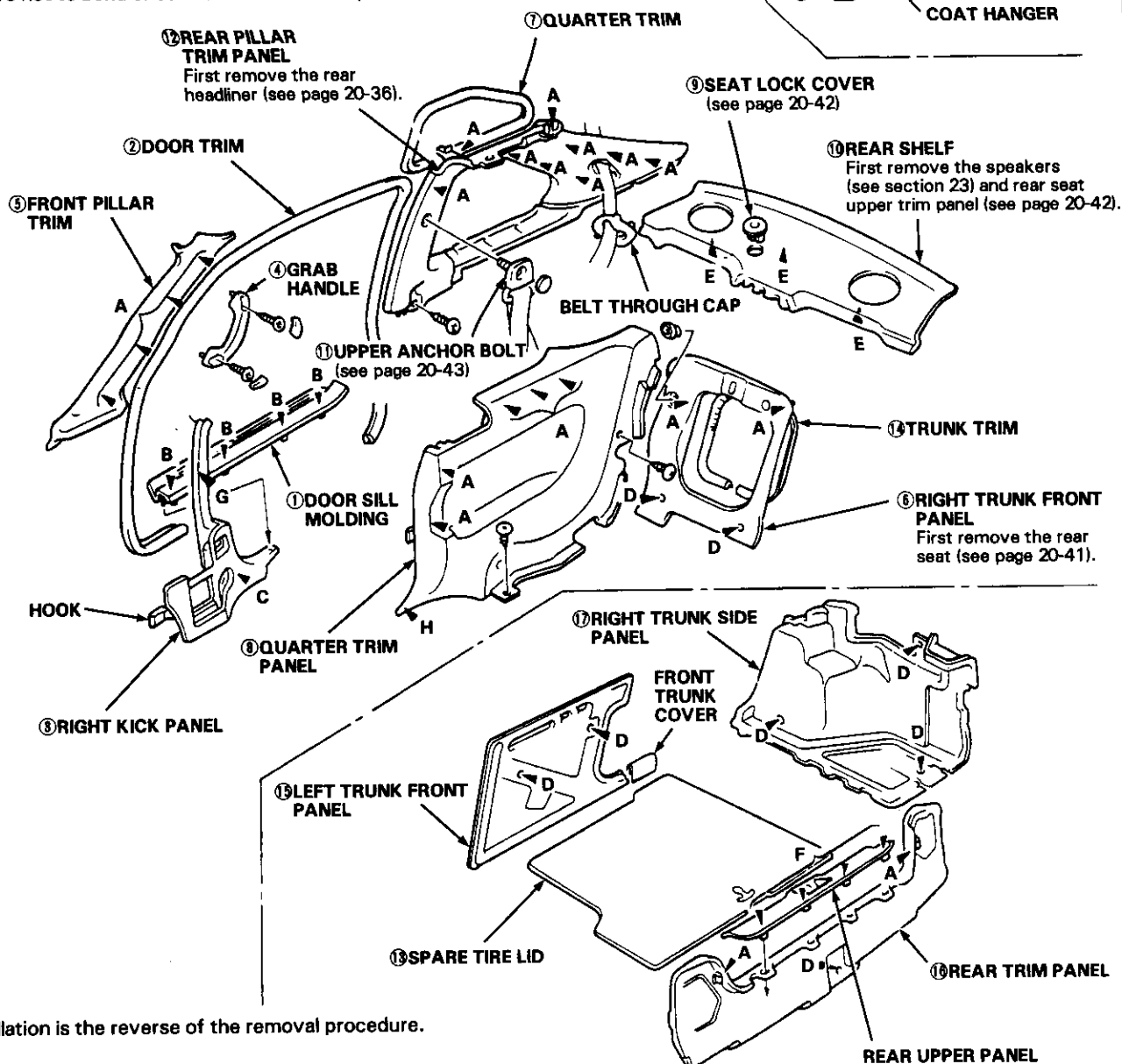
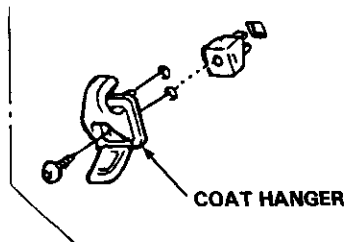

Installation is the reverse of the removal procedure.

NOTE:

If necessary, replace any damaged clips.

Seats

Front Removal

NOTE:

Take care not to scratch the seat covers and body.

1. Remove the mounting bolts covers.
2. Remove the mounting bolts and disconnect the connector, then remove the front seat.

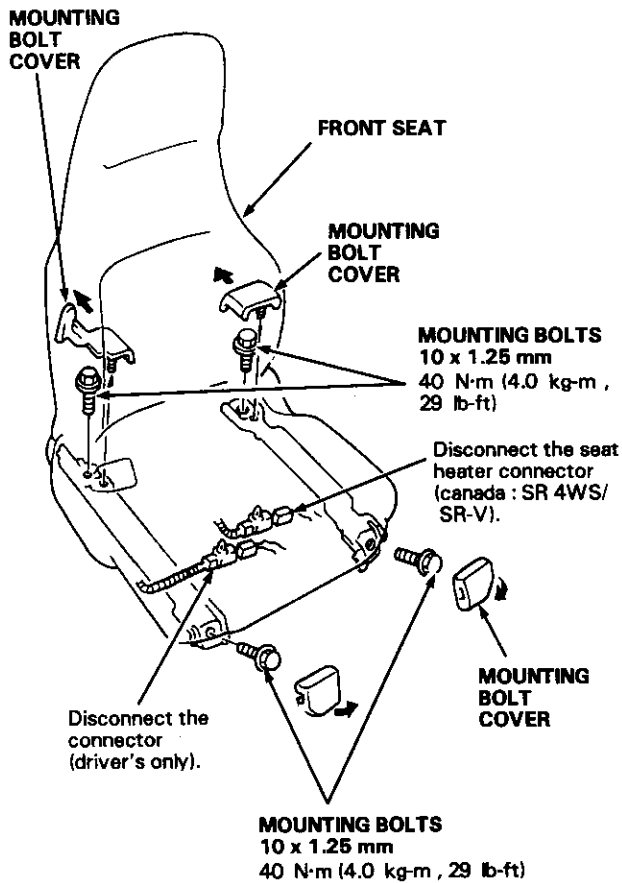

3. Installation is the reverse of the removal procedure.

Front Replacement

NOTE:

Take care not to scratch the seat covers and body.

1. Remove the front seat, then take it out from the door opening.
2. Remove the screws and knobs, then remove the recline cover.

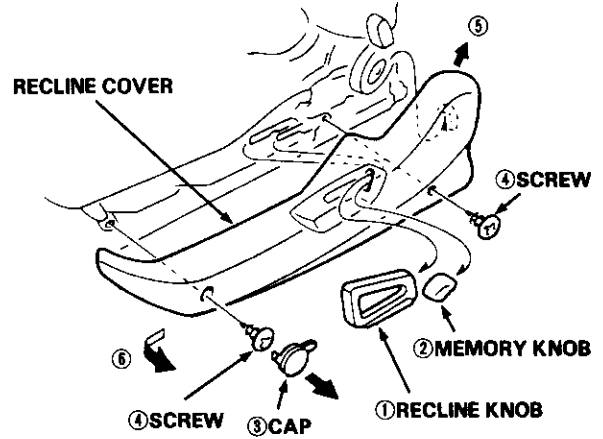

3. Remove the screws, then remove the center cover.

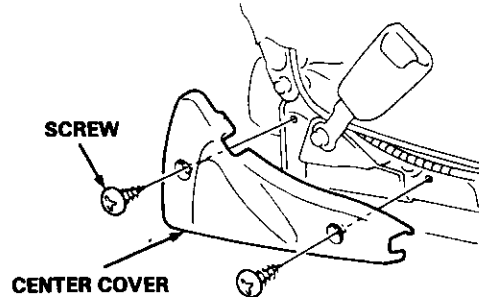

4. Remove the lower clips and fasteners from the seat-back, then fold the seat cover back.

▶ : Clip locations

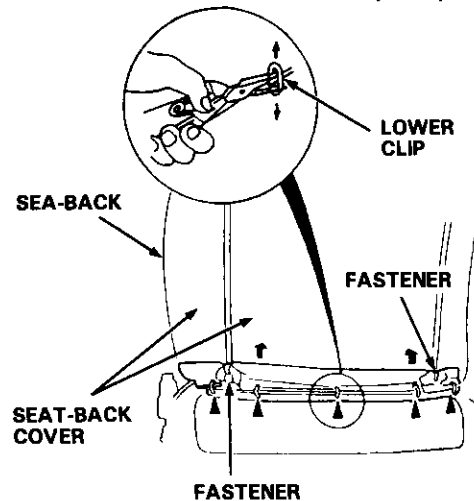



5. Fold the seat-back cover and pad back until you can see the seat-back mounting bolts.

▶ : Clip locations

NOTE:

Take care not to damage the pad.

6. Remove the seat-back and seat cushion mounting bolts and pivot nut, then remove the seat-back and seat cushion from the inner and outer seat tracks.

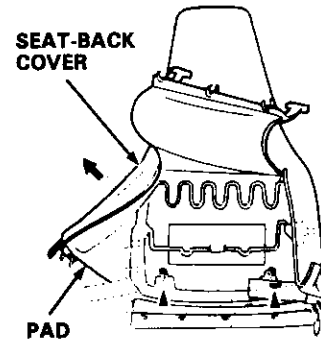

● : Clip locations

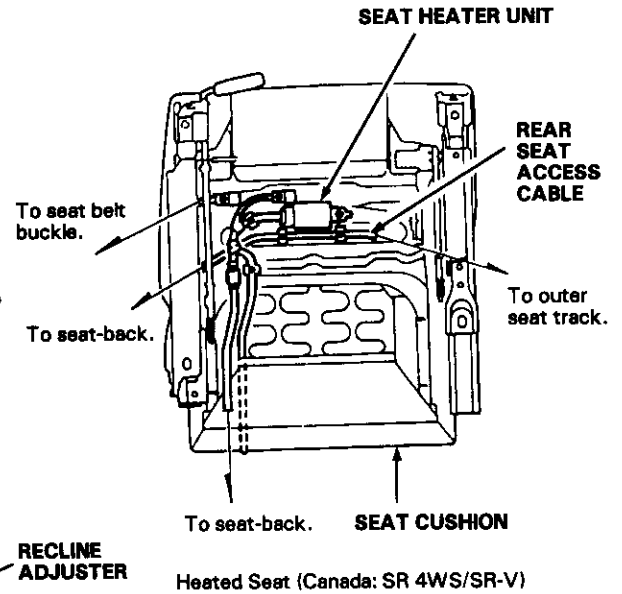
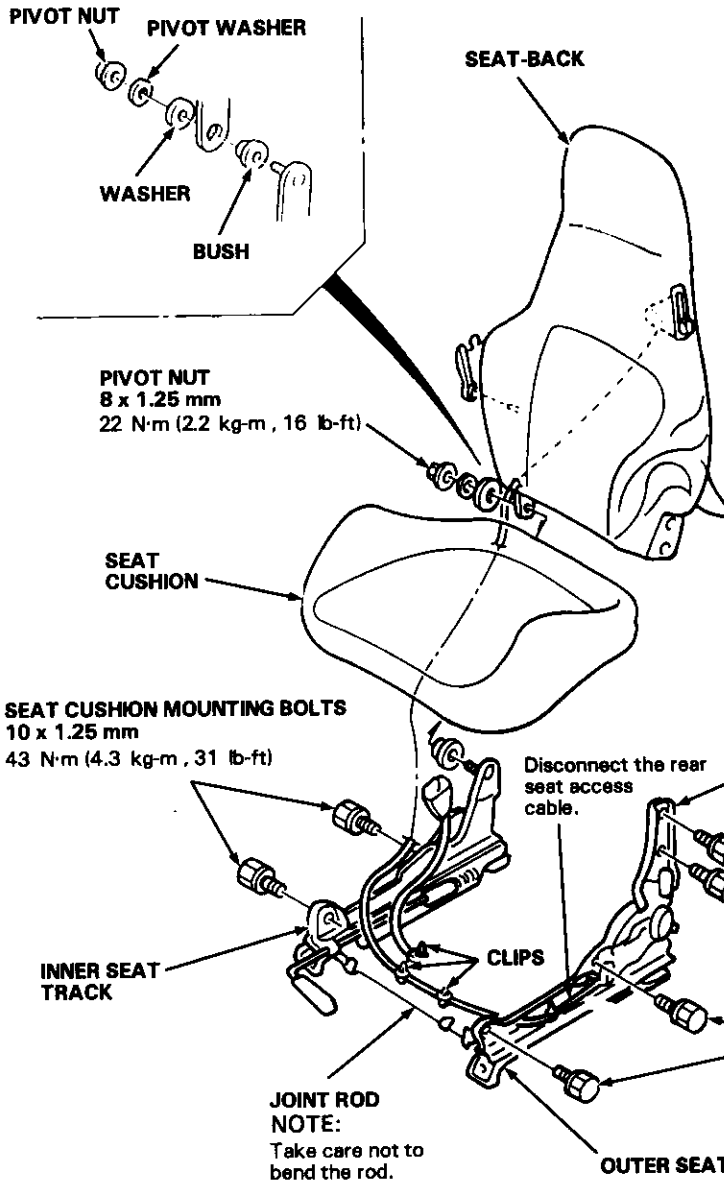

7. Installation is the reverse of the removal procedure.

NOTE:

- To prevent wrinkles when installing a seat-back cover, make sure the material is stretched evenly over the frame before securing all the clips.
- Apply grease to the moving surfaces.

Seats

Front Seat Cover Replacement

CAUTION:

Wear gloves to remove and install the seat-back and seat cushion covers.

▶ **A** : Clip locations
B : Inside spring locations Clip removal:

NOTE:

Take care not to tear the seams or damage the seat-back and seat cushion covers.

Seat-back cover removal:

1. Remove the seat-back from the inner and outer seat tracks.
2. Remove the rear seat access trim and lumbar support knob (except S model: Driver's).
3. Remove the seat-back cover by releasing all the inside springs.

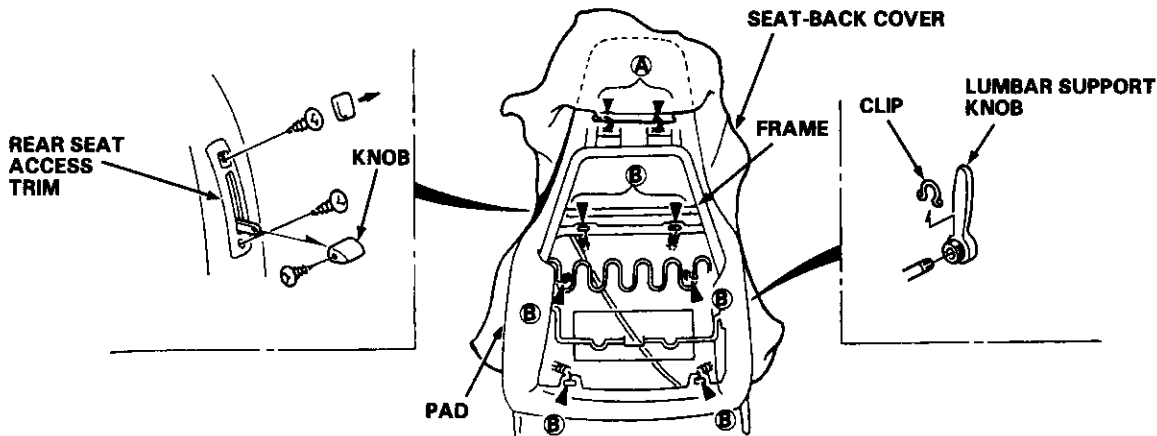
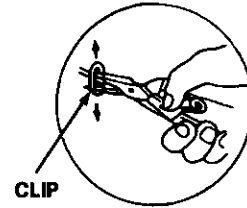

Seat cushion cover removal:

1. Remove the seat cushion from the inner and outer seat tracks.
2. Remove all clips from under the seat cushion, then loosen the seat cushion cover.
3. Pull back the edge of the seat cushion cover all the way around, then release the pad clips and inside springs.

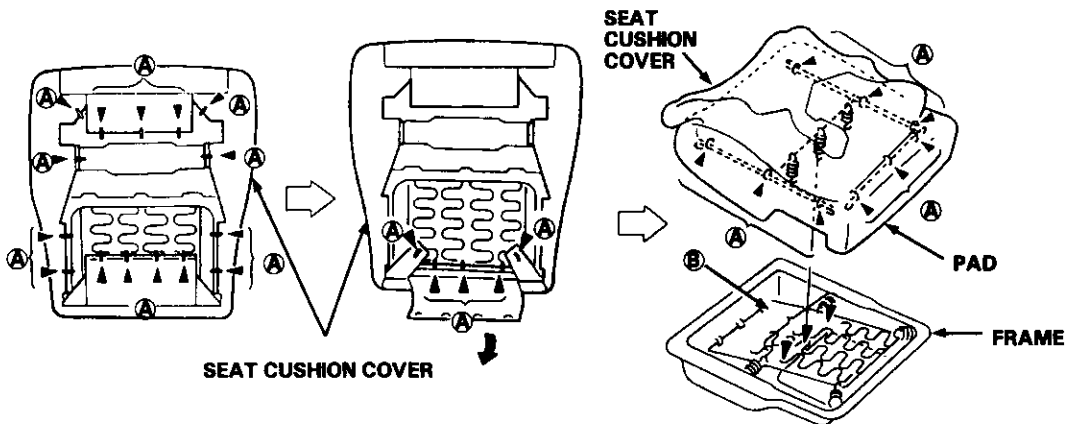

Clip installation:

Installation is the reverse of the removal procedure.

NOTE:

- To prevent wrinkles, make sure the material is stretched evenly over the frame before securing all the clips and inside springs.
- If necessary, replace any damaged inside springs.
- Replace the clips.

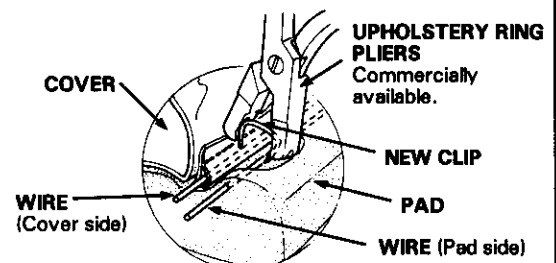



Rear Replacement

Disassemble in numbered sequence.

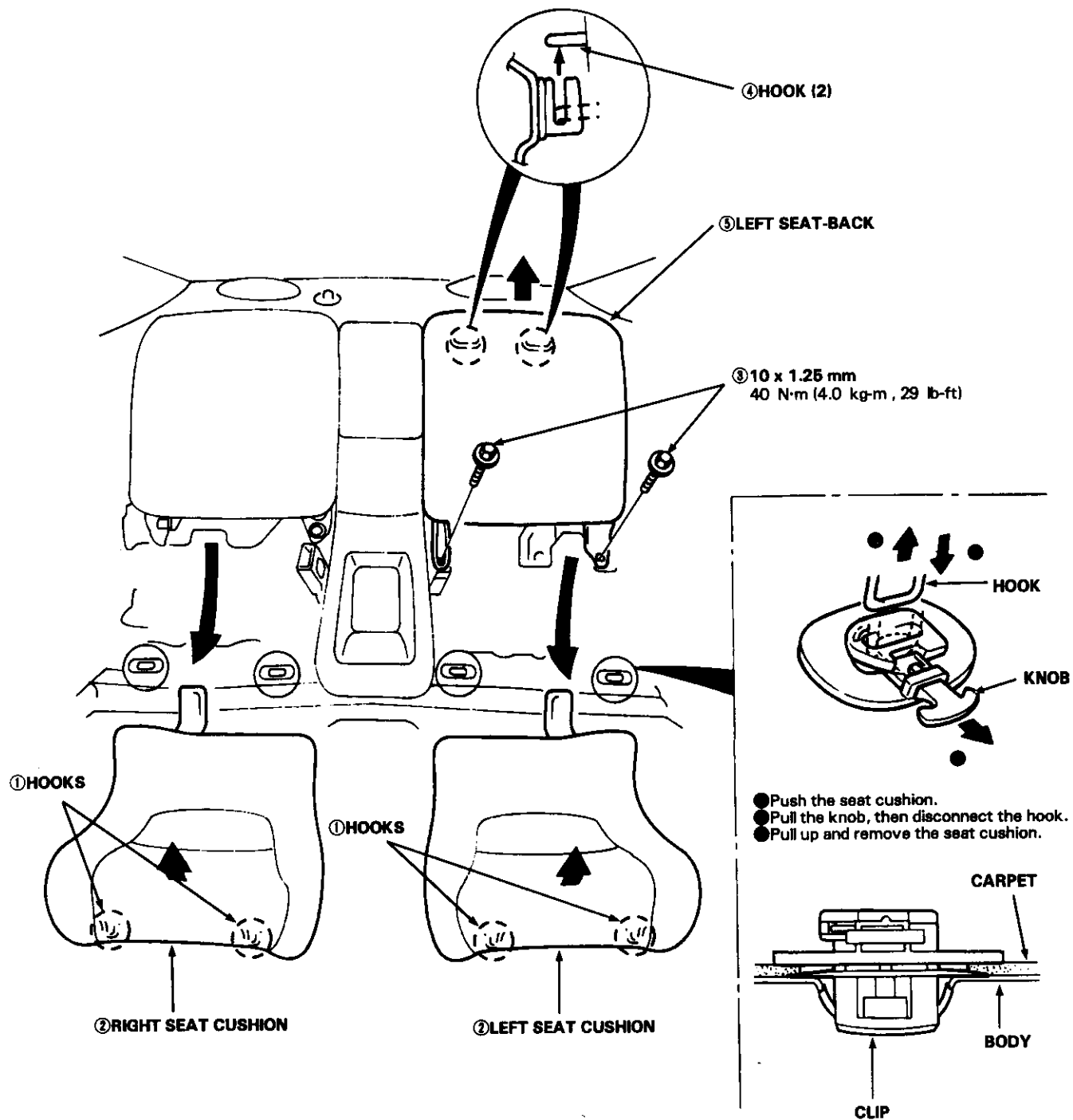

(cont'd)

Seats

Rear Replacement (cont'd)

Disassemble in numbered sequence.

① 6 x 1.0 mm
10 N·m (1.0 kg-m, 7 lb-ft)

RIGHT PIVOT
BRACKET

② RIGHT SEAT-
BACK

LEFT PIVOT
BRACKET

Rear seat latch/Lock cylinder removal:

SEAT LOCK COVER

REAR SHELF

SEAT LOCK
COVER

Pry here.

6 x 1.0 mm
10 N·m (1.0 kg-m,
7 lb-ft)

LOCK CYLINDER

Remove the rear
shelf (see page 20-37).

LOCK ROD

NOTE:

Take care not to
bend the lock rod.

REAR SEAT
LATCH

6 x 1.0 mm
10 N·m (1.0 kg-m, 7 lb-ft)

HOOKS

6 x 1.0 mm
10 N·m (1.0 kg-m, 7 lb-ft)

RIGHT PIVOT BRACKET
Remove the quarter trim
panel (see page 20-37).

LEFT PIVOT BRACKET
Remove the seat center
pad (see page 20-42).

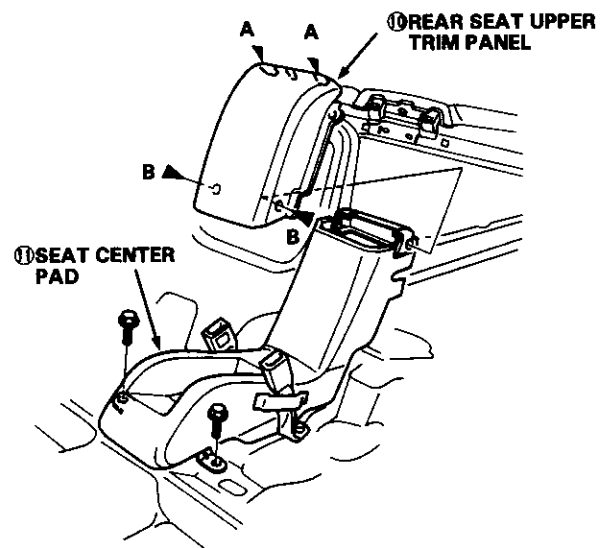

Installation is the reverse of the removal procedure.

NOTE:

- Before attaching the seat-back and seat cushion, make sure there are no twists in the seat belt.
- When installing the seat cushion, position the seat belts correctly.

► : Clip locations

A



B





Seat Belts

Front Replacement

CAUTION:

Check the seat belts for damage and replace them if necessary. Be careful not to damage them during removal and installation.

1. Remove:

- Front seat (see page 20-38)
- Rear seat (see page 20-41)
- Door trim (see page 20-37)
- Rear shelf (see page 20-37)
- Right trunk front panel (see page 20-37)
- Quarter trim panel (see page 20-37)

2. Remove the seat belt guide and center cover.

3. Remove the all three anchor bolts, retractor bolt and retractor mounting bolt, then remove the seat belt and seat belt buckle.

NOTE:

When removing the anchor bolts and retractor bolt, use a 17 mm socket or box-end wrench.

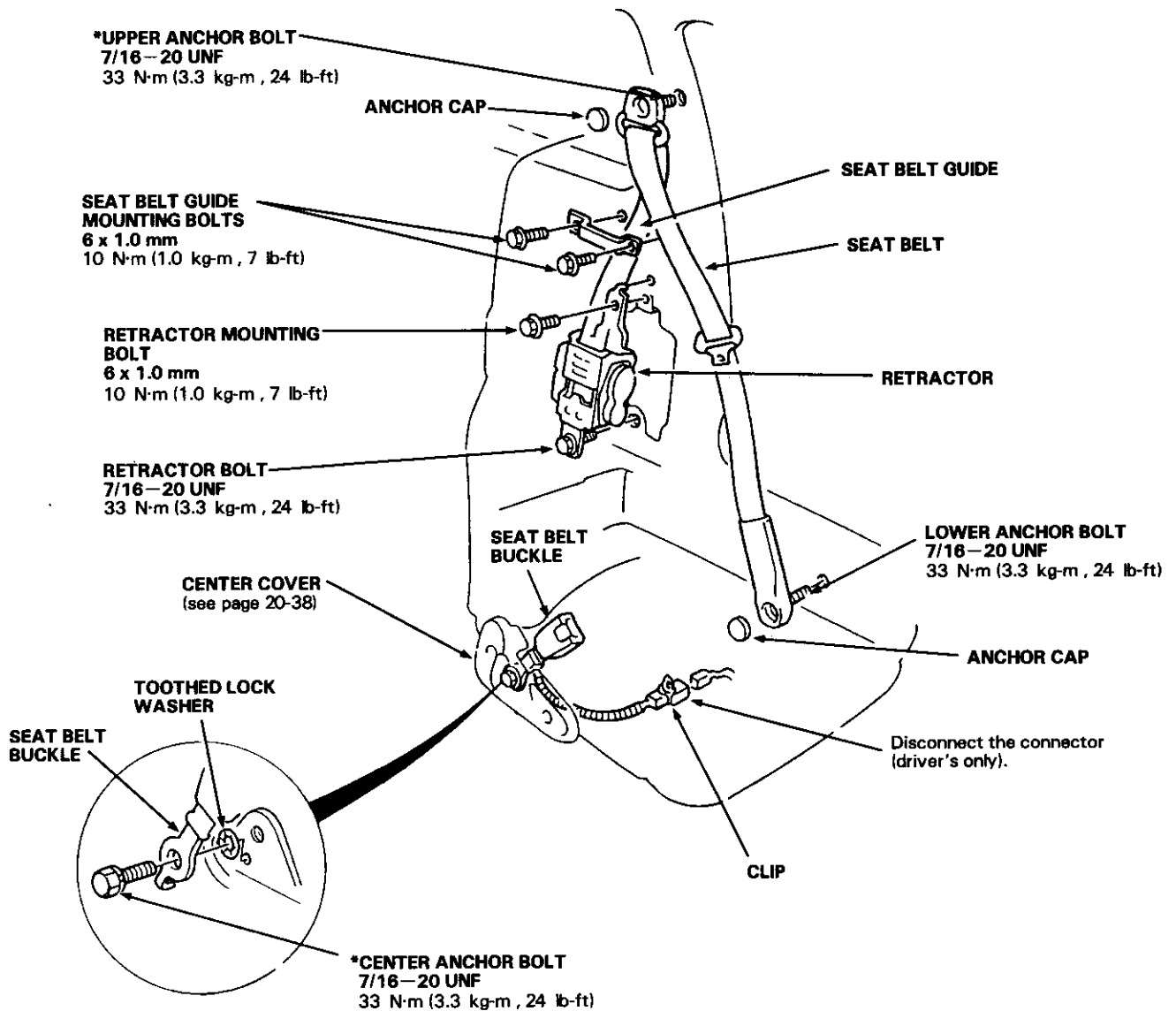

(cont'd)

Seat Belts

Front Replacement (cont'd)

Anchor bolt construction:

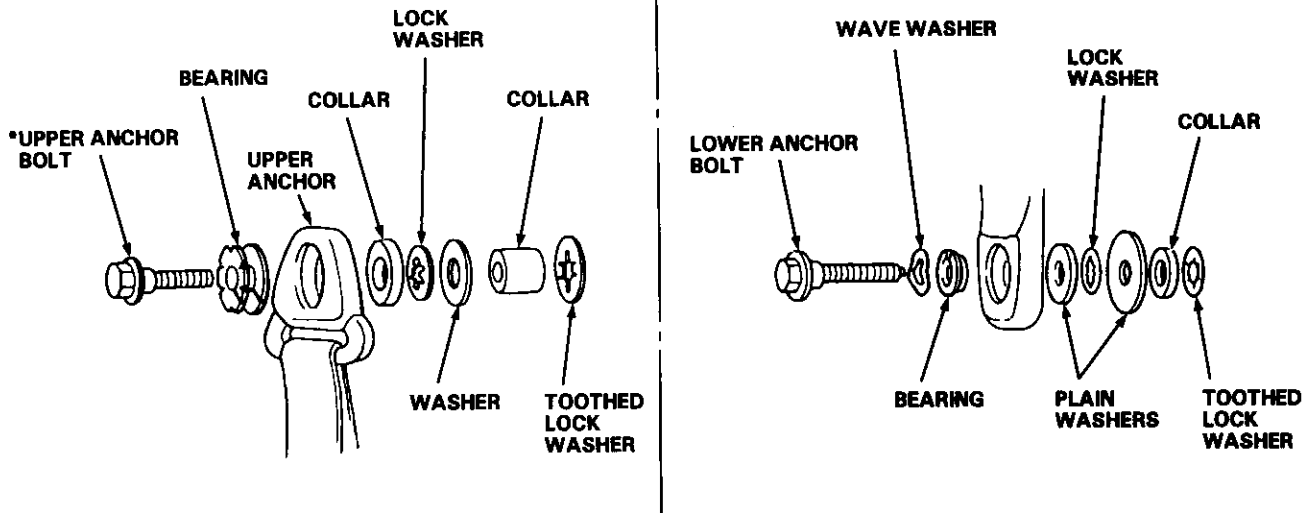

4. Check that the retractor locking mechanism functions as described on page 20-46.
5. Installation is the reverse of the removal procedure.

NOTE:

- Make sure you assemble the washers and collars on the upper and lower anchor bolts as shown.
- Before attaching the quarter trim panel, make sure there are no twists or kinks in the seat belts.
- On reassembly, replace the upper anchor bolt and center anchor bolt (*) and use liquid thread lock.



Rear Replacement

CAUTION:

Check the seat belts for damage and replace them if necessary. Be careful not to damage them during removal and installation.

1. Remove:

- Front seat (see page 20-38)
- Rear seat (see page 20-41)
- Seat center pad (see page 20-42)
- Rear shelf (see page 20-37)
- Center console (see page 20-51)
- Door trim (see page 20-37)
- Right trunk front panel (see page 20-37)
- Quarter trim panel (see page 20-37)
- Headliner (see page 20-36)
- Rear pillar trim panel (see page 20-37)

2. Detach the seat belt guide.

3. Remove the all three anchor bolts, retractor bolt and retractor mounting bolt, then remove the seat belt and seat belt buckle.

NOTE:

When removing the anchor bolts and retractor bolt, use a 17 mm socket or box-end wrench.

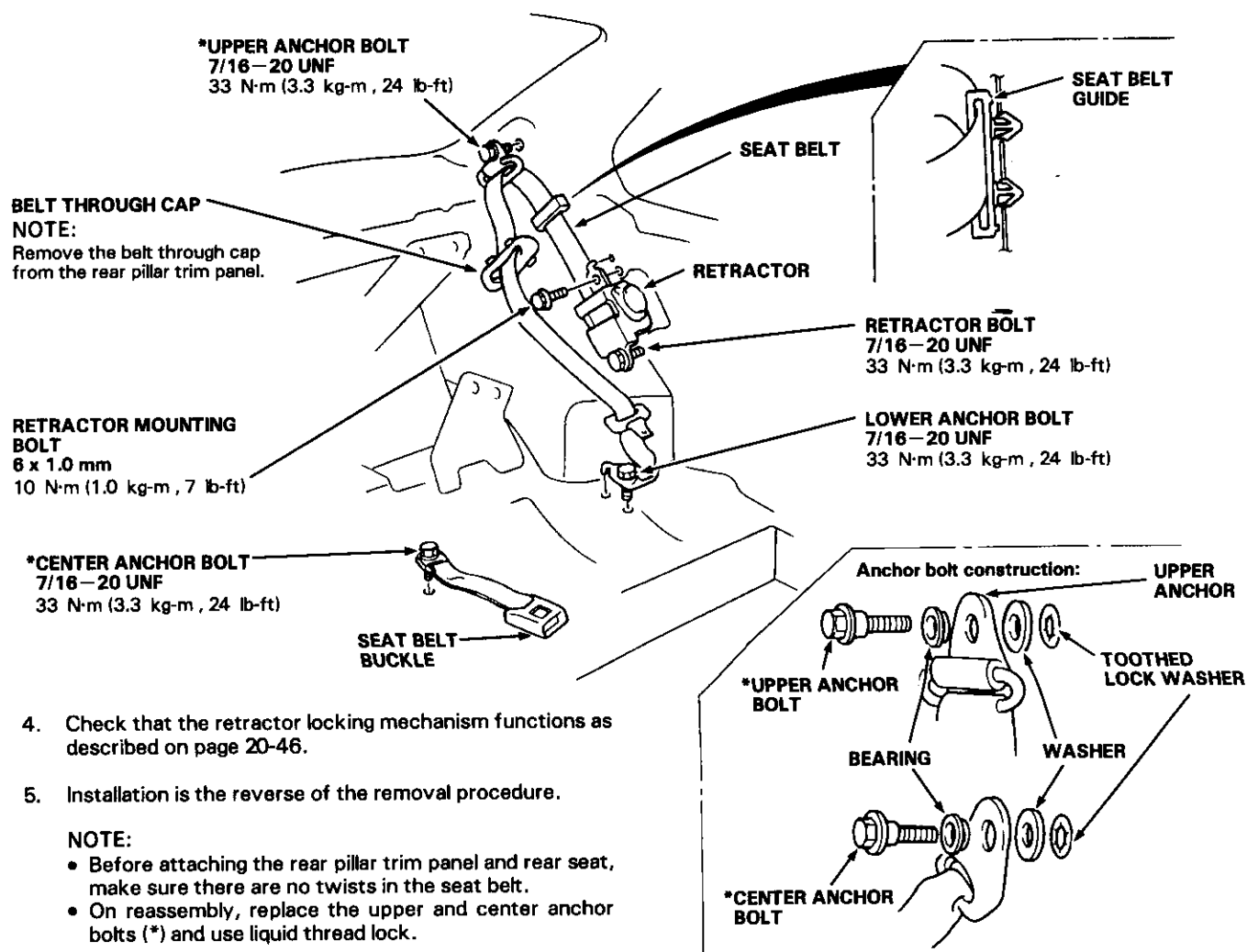

4. Check that the retractor locking mechanism functions as described on page 20-46.

5. Installation is the reverse of the removal procedure.

NOTE:

- Before attaching the rear pillar trim panel and rear seat, make sure there are no twists in the seat belt.
- On reassembly, replace the upper and center anchor bolts (*) and use liquid thread lock.

Seat Belts

Inspection

Retractor Inspection

1. Before installing the retractor, check that the seat belt can be pulled out freely.
2. Make sure that the seat belt does not lock when the retractor is leaned slowly up to 15° from the mounted position. The seat belt should lock when the retractor is leaned over 40° .

CAUTION:

Do not attempt to disassemble the retractor.

On-the-Car Seat Belt Inspection

1. Check that the seat belt is not twisted or caught on anything.
2. After installing the anchors, check for free movement on the anchor bolts. If necessary, remove the anchor bolts and check that the washers and other parts are not damaged or improperly installed.
3. Check the seat belts for damage or discoloration. Clean with a shop towel if necessary.

CAUTION:

Use only soap and water to clean.

NOTE:

Dirt build-up in the metal loops of the upper anchors can cause the seat belts to retract slowly. Wipe the inside of the loops with a clean cloth dampened in isopropyl alcohol.

4. Check that the seat belt does not lock when pulled out slowly. The seat belt is designed to lock only during a sudden stop or impact.
5. Make sure that the seat belt will retract automatically when released.
6. Replace the seat belt with a new one if there is any abnormality.

Front: *: Mounted Position

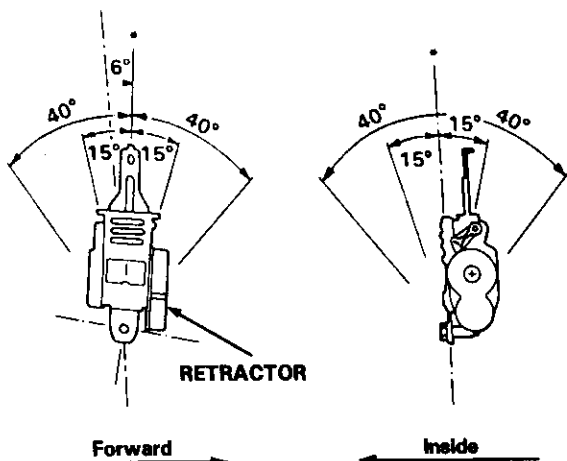

Rear:

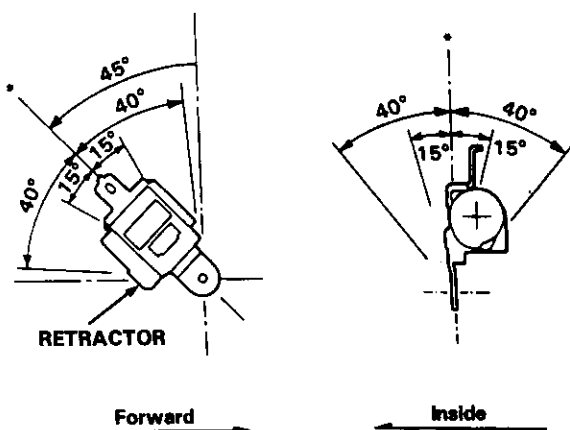

3. Replace the seat belt with a new one if there is any abnormality.



Child Seat Anchor Plate

Attachment points are provided for a rear seat mounted child restraint system which uses a top tether.

The attachment points are located on the rear shelf, just behind the rear seat-back.

When using a child seat with a top tether, use a razor blade or sharp knife to carefully cut a 1 inch diameter circle at the location of the attachment points and install the child seat anchor plate securely.

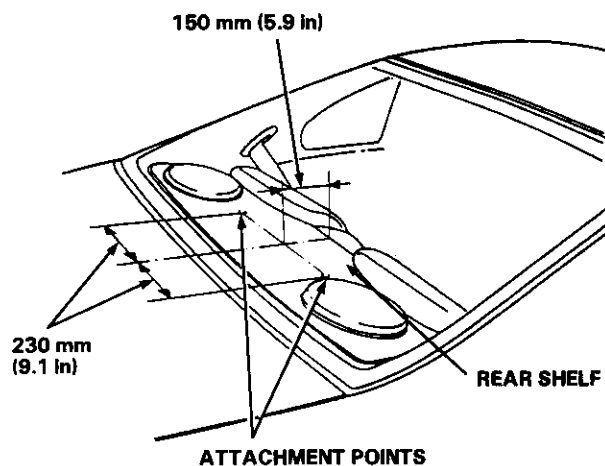

8 x 1.25 mm
22 N-m (2.2 kg-m, 16 lb-ft)

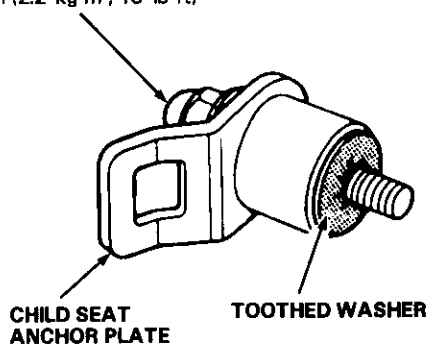

NOTE:

- Do not remove the toothed washer from the child seat anchor plate. Use the child seat anchor plate with the toothed washer attached to it.
- When installing a child seat on the rear seat, follow the instructions of the manufacturer of the child seat.
- Additional anchor plates are available.

▲ WARNING

- Do not use the child seat anchor plate for any other purpose; it is designed exclusively for installation of a child seat.
- Make sure the rear seat-back is locked firmly when installing a child seat.

Carpet

Replacement

SRS wire harnesses are routed near the carpet.

CAUTION:

- All SRS electrical wiring harnesses are covered with yellow outer insulation.
- Before disconnecting the SRS wire harness, install the short connector(s) on the airbag(s).
- Replace the entire affected SRS harness assembly if it has an open circuit or damaged wiring.

NOTE:

The radio may have a coded theft protection circuit. Be sure to get the customer's code number before

- Disconnecting the battery.
- Removing the No. 43 (10 A) fuse (in the under-hood fuse/relay box).
- Removing the radio.

After service, reconnect power to the radio and turn it on. When the word "CODE" is displayed, enter the customer's 5-digit code to restore radio operation.

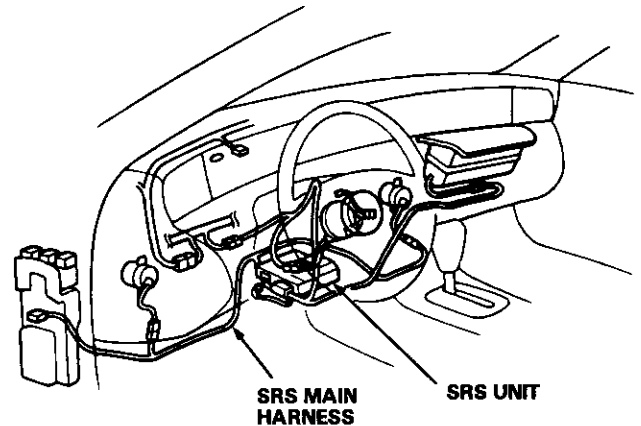

1. Remove:

- Front seats (see page 20-38)
- Consols (see page 20-50)
- Center panel (see page 20-51)
- Dashboard lower cover, knee bolster (see page 20-53)
- Glove box (see page 20-53)
- Rear seat (see page 20-41)
- Seat center pad (see page 20-42)

- Opener cover (see page 20-67)
- Front seat belt lower anchor (see page 20-43)
- Door sill molding and door trim (see page 20-37)
- Kick panel (see page 20-37)
- Right trunk front panel and quarter trim panel (see page 20-37)
- Footrest

2. Pry out the clips and remove the retainer from the door sill flange.

3. Detach the fastener in the driver's side carpet, then pull back the carpet at the bottom of heater.

4. Remove the carpet by sliding it rearward.

NOTE:

Take care not to damage, wrinkle or twist the carpet.

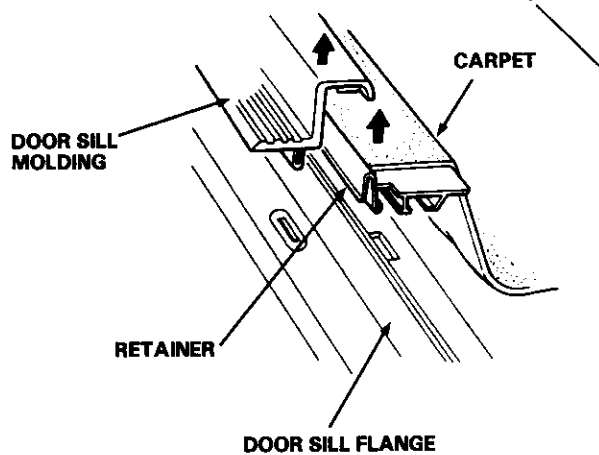
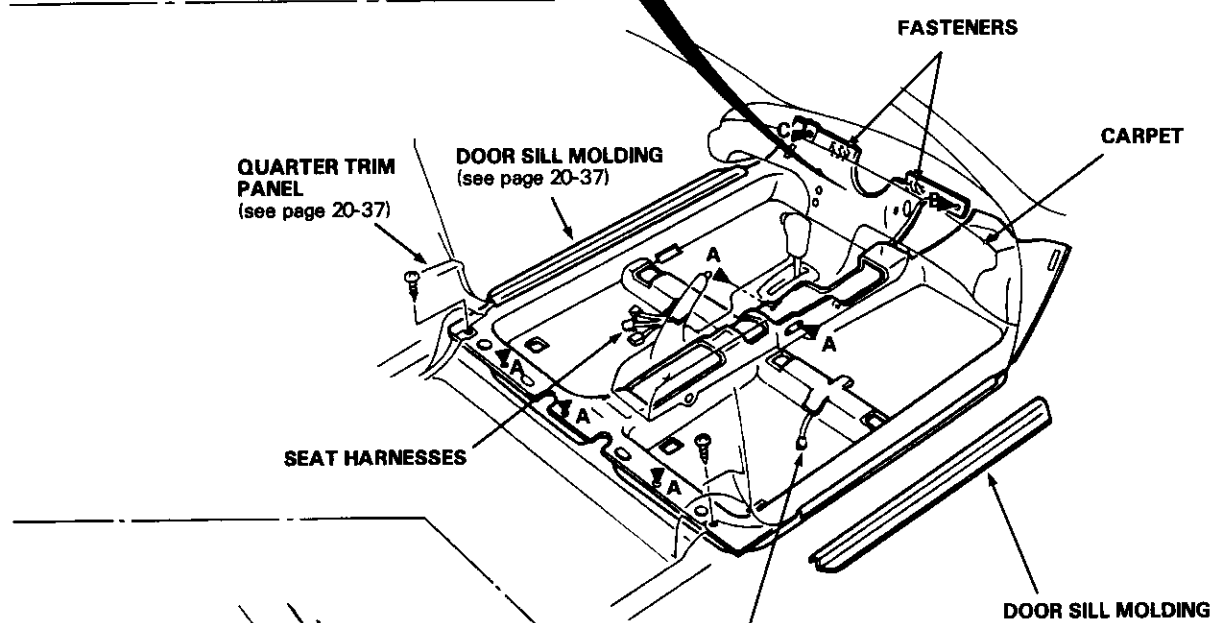
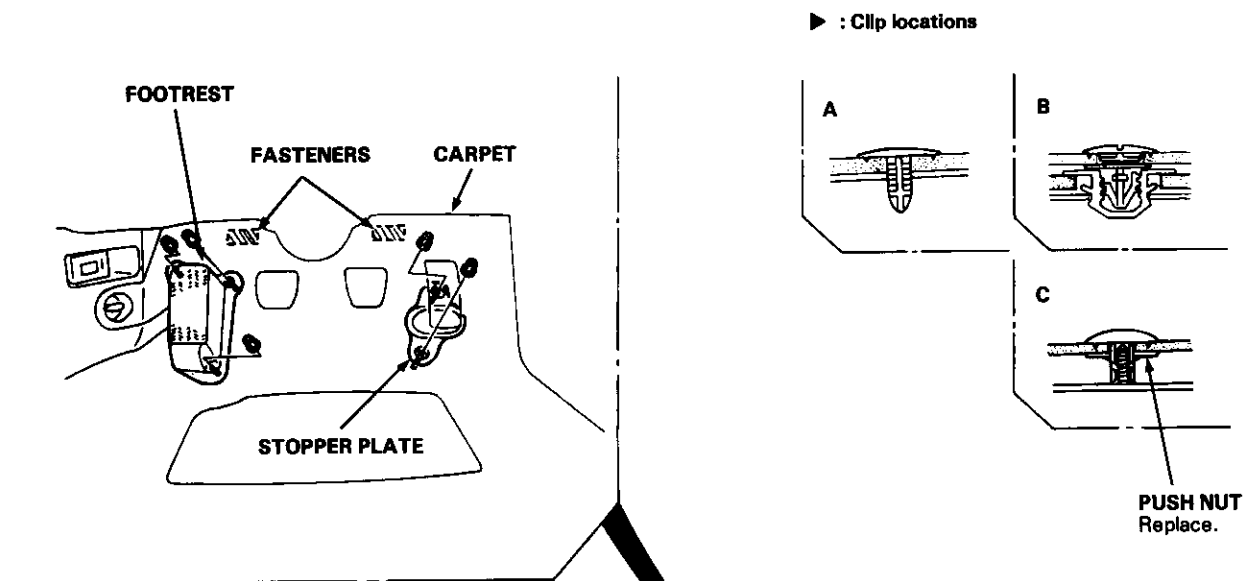

5. Installation is the reverse of the removal procedure.

NOTE:

- Take care not to damage, wrinkle or twist the carpet.
- Make sure the seat harnesses are routed correctly.

Consoles

Replacement

SRS wire harnesses are routed near the front console.

CAUTION:

- All SRS electrical wiring harnesses are covered with yellow outer insulation.
- Before disconnecting the SRS wire harness, install the short connector(s) on the airbag(s).
- Replace the entire affected SRS harness assembly if it has an open circuit or damaged wiring.

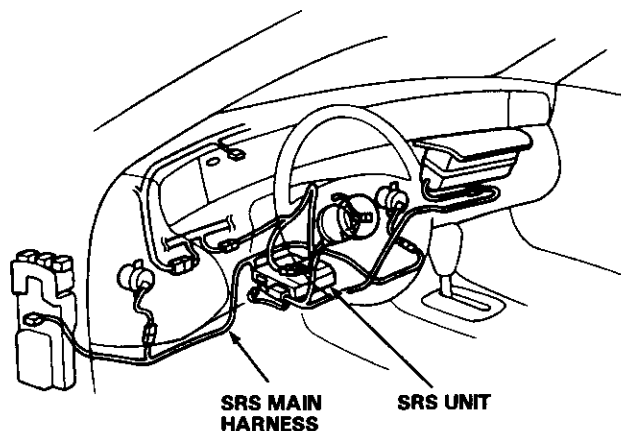

CAUTION:

- To prevent damage to the shift lever knob and shift indicator trim ring, wrap them with a shop towel.
- When prying with a flat tip screwdriver, wrap it with protective tape to prevent damage.

NOTE:

- Take care not to scratch the front and center consoles and dashboard.
- Slide the front seat fully to the rear.

► : Clip locations

Automatic transmission model:

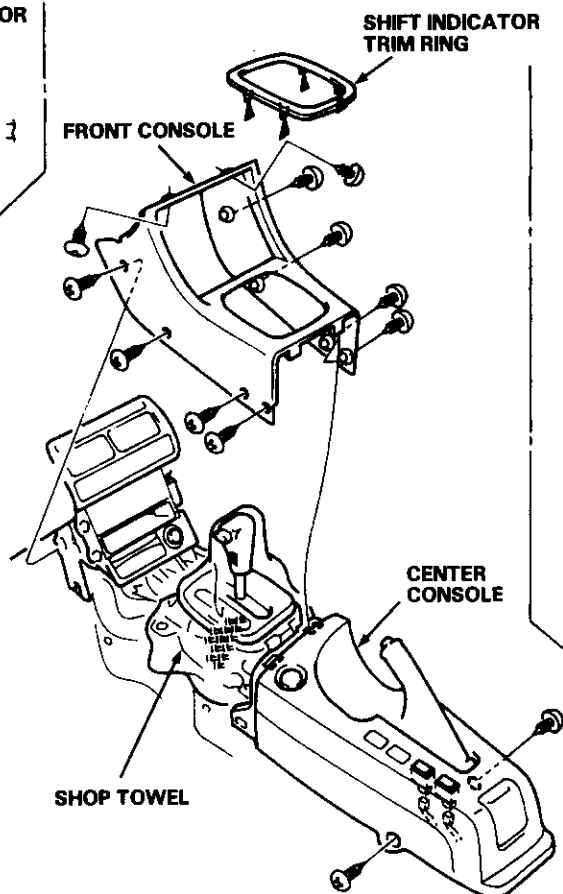
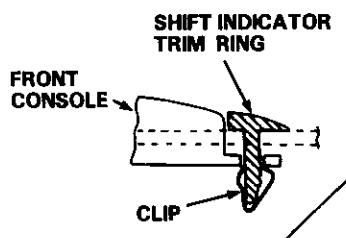

Manual transmission model:

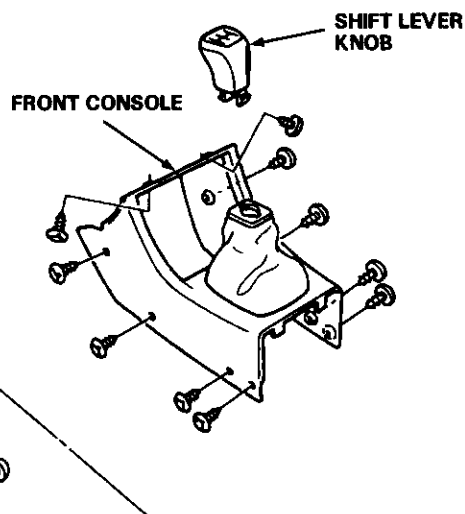

Installation is the reverse of the removal procedure.



Dashboard

Component Removal/Installation

SRS wire harnesses are routed near the dashboard and steering column.

CAUTION:

- All SRS electrical wiring harnesses are covered with yellow outer insulation.
- Before disconnecting the SRS wire harness, install the short connector(s) on the airbag(s).
- Replace the entire affected SRS harness assembly if it has an open circuit or damaged wiring.
- After installation of the gauge assembly, recheck the operation of the SRS indicator light.

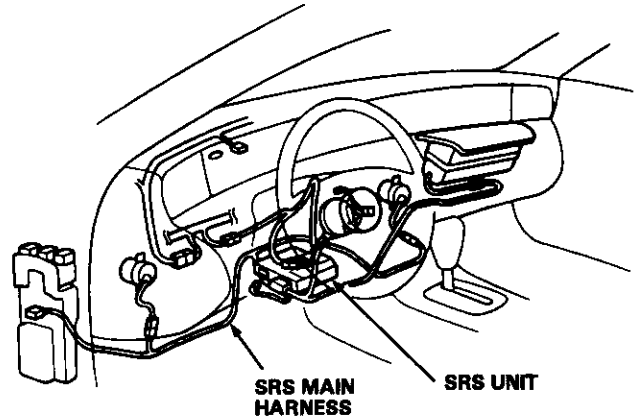

NOTE:

- The radio may have a coded theft protection circuit. Be sure to get the customer's code number before
 - Disconnecting the battery.
 - Removing the No. 43 (10 A) fuse (in the under-hood fuse/relay box).
 - Removing the radio.

After service, reconnect power to the radio and turn it on. When the word "CODE" is displayed, enter the customer's 5-digit code to restore radio operation.

- Take care not to scratch the dashboard and related parts.
- Do not drop the screws inside the dashboard.

CAUTION:

When prying with a flat tip screwdriver, wrap it with protective tape to prevent damage.

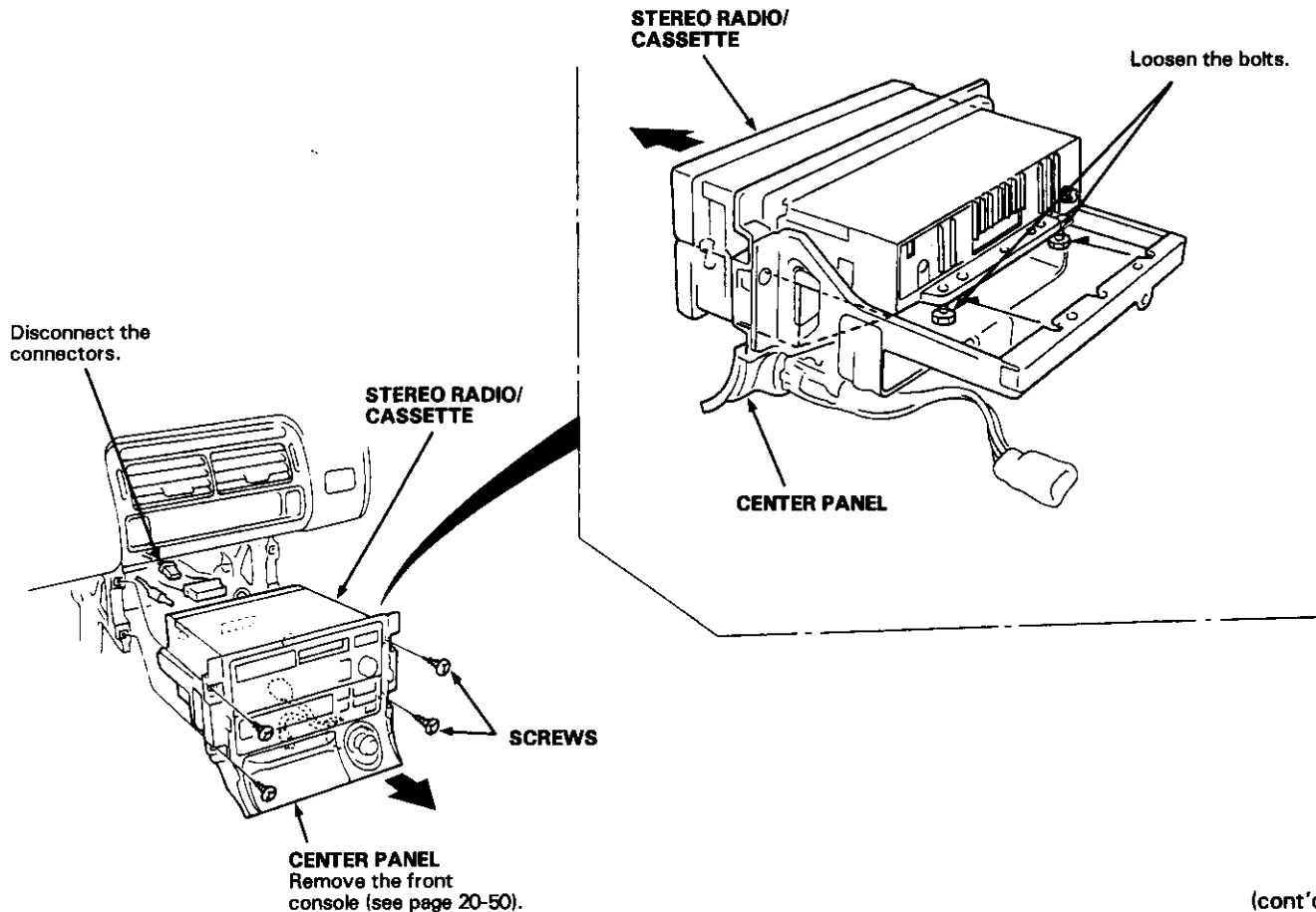

(cont'd)

Dashboard

Component Removal/Installation (cont'd)

NOTE:

- Take care not to scratch the dashboard and related parts.
- Do not drop the screws inside the dashboard.

CAUTION:

When prying with a flat tip screwdriver, wrap it with protective tape to prevent damage.

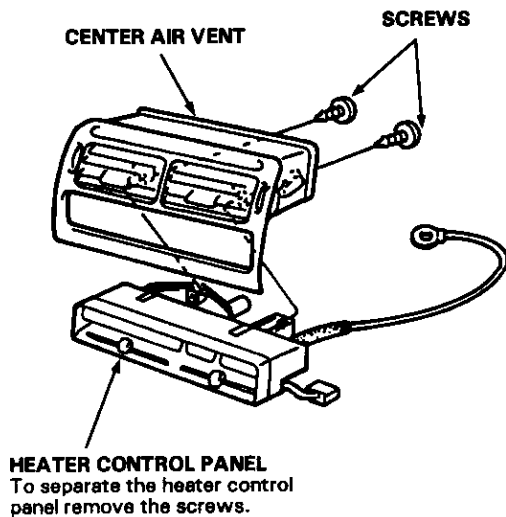
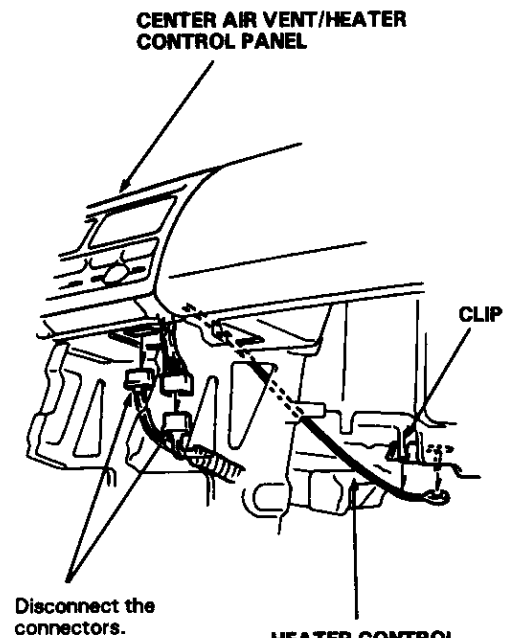
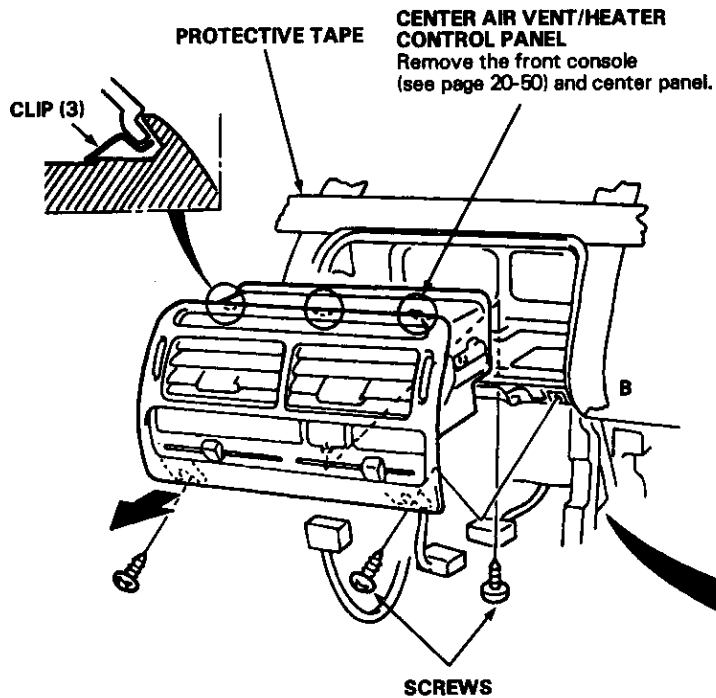

HEATER CONTROL CABLE

NOTE:

Take care not to bend the heater control cable.



Passenger's:

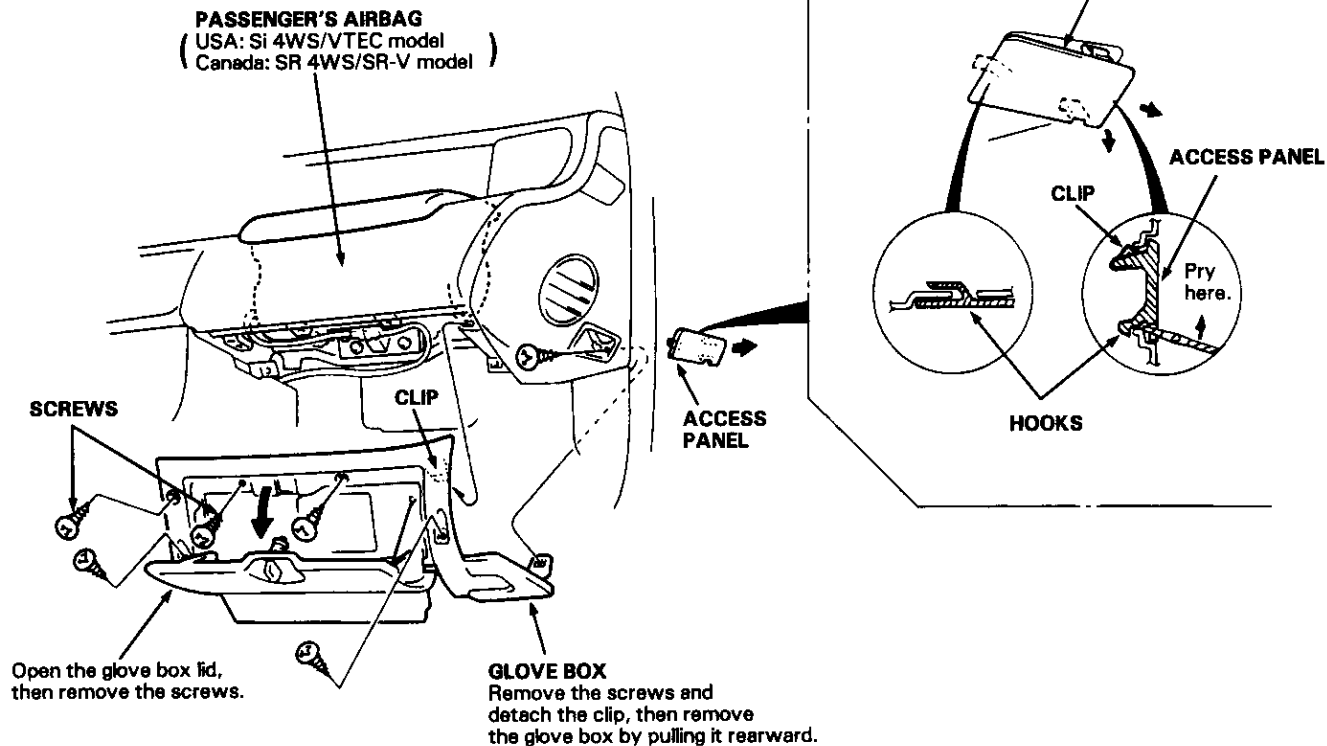

Driver's:

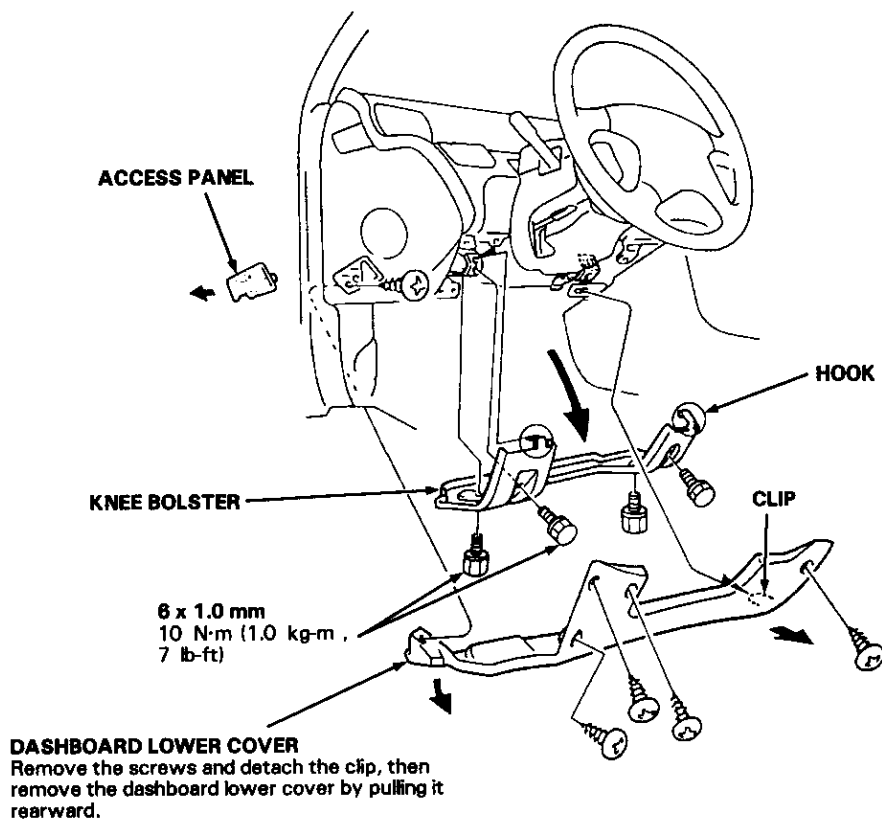

(cont'd)

Dashboard

Component Removal/Installation (cont'd)

Disassemble in numbered sequence.

CAUTION:

When prying with a flat tip screwdriver, wrap it with protective tape to prevent damage.

NOTE:

- Do not drop the screws inside the dashboard.
- Take care not to scratch the dashboard and related parts.

► : Clip, hook locations

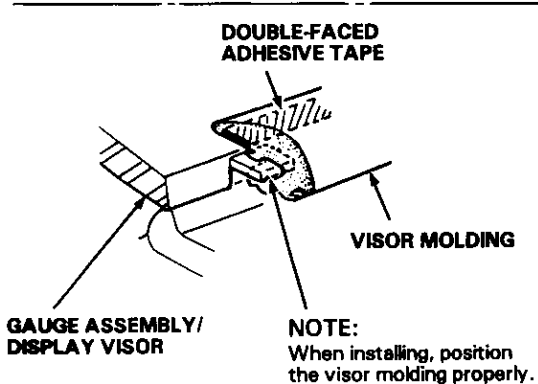
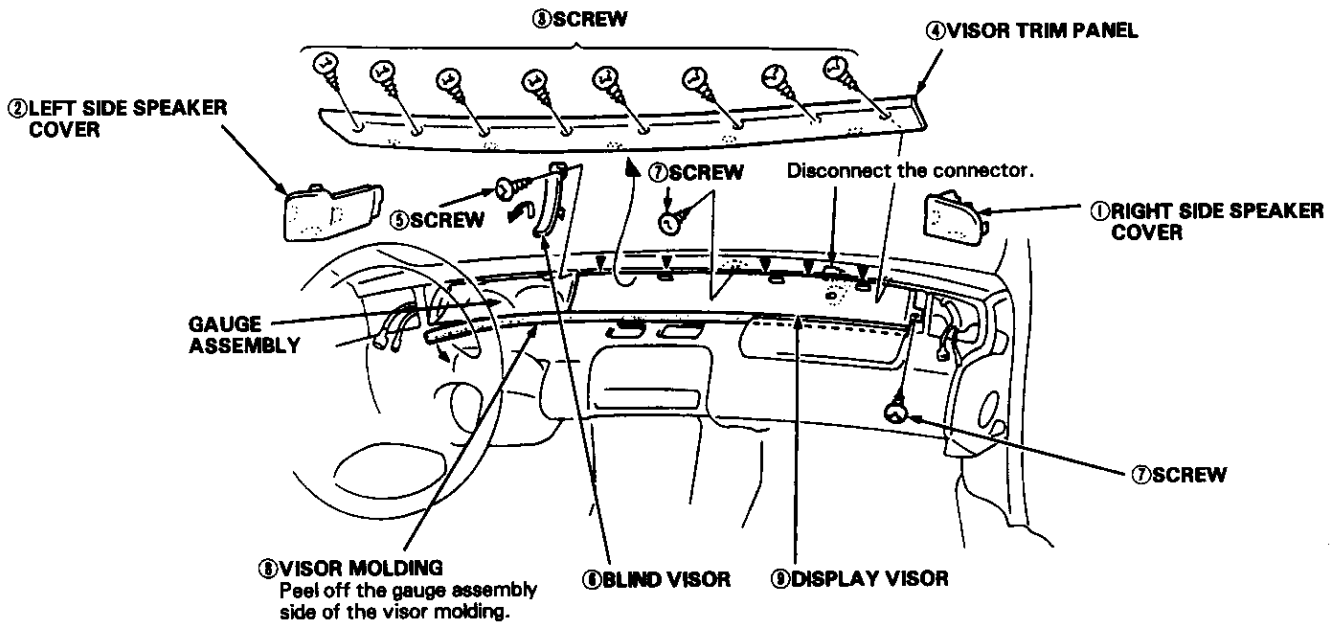
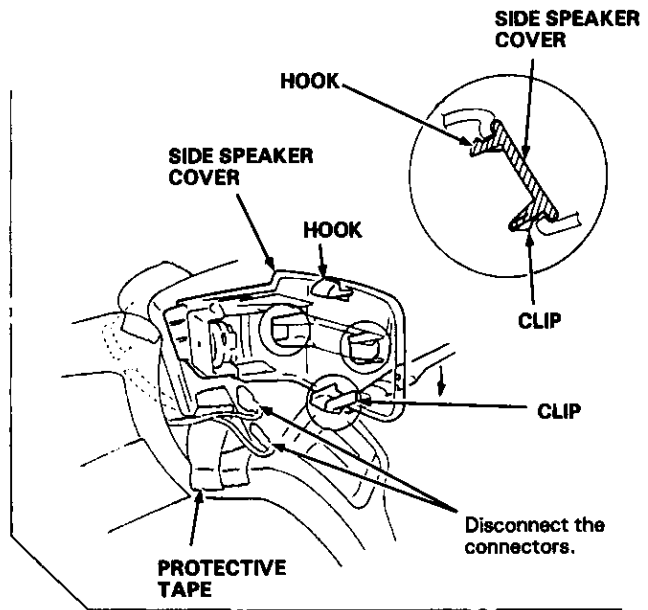
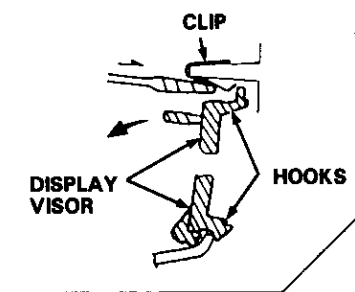

Installation is the reverse of the removal procedure.

NOTE:
Take care not to scratch the dashboard.



Replacement

SRS wire harnesses are routed near the dashboard and steering column.

CAUTION:

- All SRS electrical wiring harnesses are covered with yellow outer insulation.
- Before disconnecting the SRS wire harness, install the short connector(s) on the airbag(s).
- Replace the entire affected SRS harness assembly if it has an open circuit or damaged wiring.
- After installation of the gauge assembly, recheck the operation of the SRS indicator light.

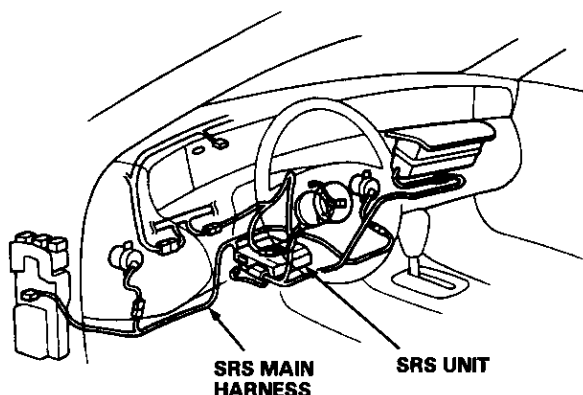

NOTE:

The radio may have a coded theft protection circuit. Be sure to get the customer's code number before

- Disconnecting the battery.
- Removing the No. 43 (10 A) fuse (in the under-hood fuse/relay box).
- Removing the radio.

After service, reconnect power to the radio and turn it on. When the word "CODE" is displayed, enter the customer's 5-digit code to restore radio operation.

1. To remove the dashboard, first remove the:
 - Front seats (see page 20-38)
 - Front console (see page 20-50)
 - Center panel (see page 20-51)
 - Glove box (see page 20-53)
 - Dashboard lower cover (see page 20-53)
 - Air conditioning duct

2. Lower the steering column (see section 17).

▲WARNING

To avoid accidental deployment and possible injury always install the short connector on the airbag connector when the harness is disconnected.

NOTE:

Before lowering the steering column, remove the steering column lower cover, then disconnect the connector between the cable reel and airbag. Connect the short connector (RED) to the airbag connector (see page 23-294).

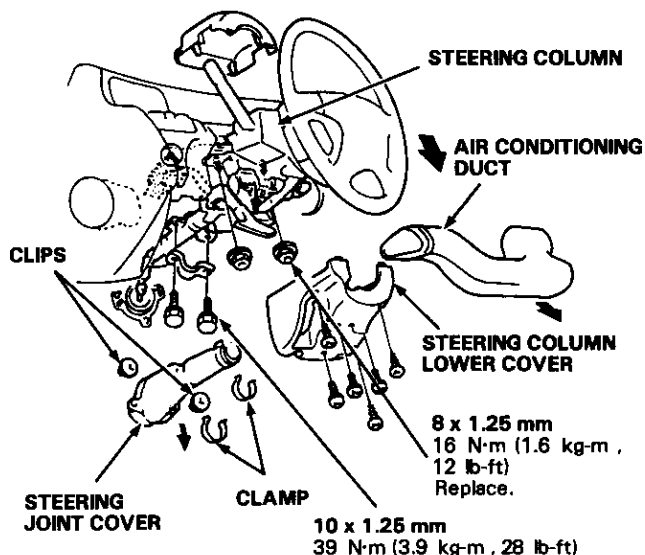
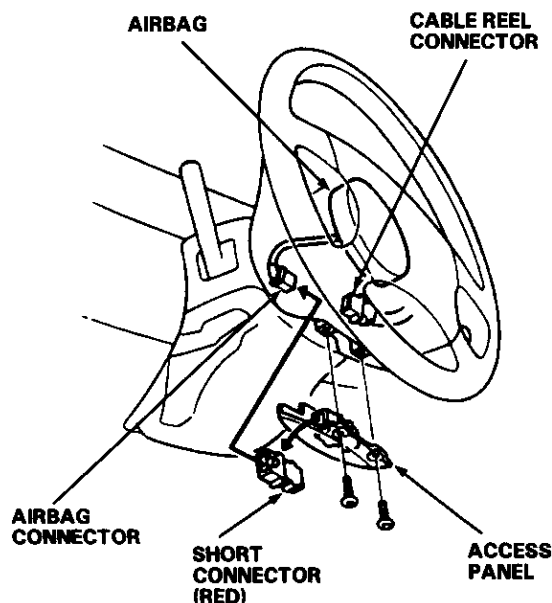

NOTE:

To prevent damage to the steering column, wrap it with a shop towel.

(cont'd)

Dashboard

Replacement (cont'd)

3. Remove the nuts, then remove the airbag bracket.

WARNING

To avoid accidental deployment and possible injury always install the short connector on the airbag connector when the harness is disconnected.

NOTE:

Disconnect the connector between the passenger's airbag and SRS wire harness.

Connect the short connector (RED) to the airbag connector (see page 23-295).

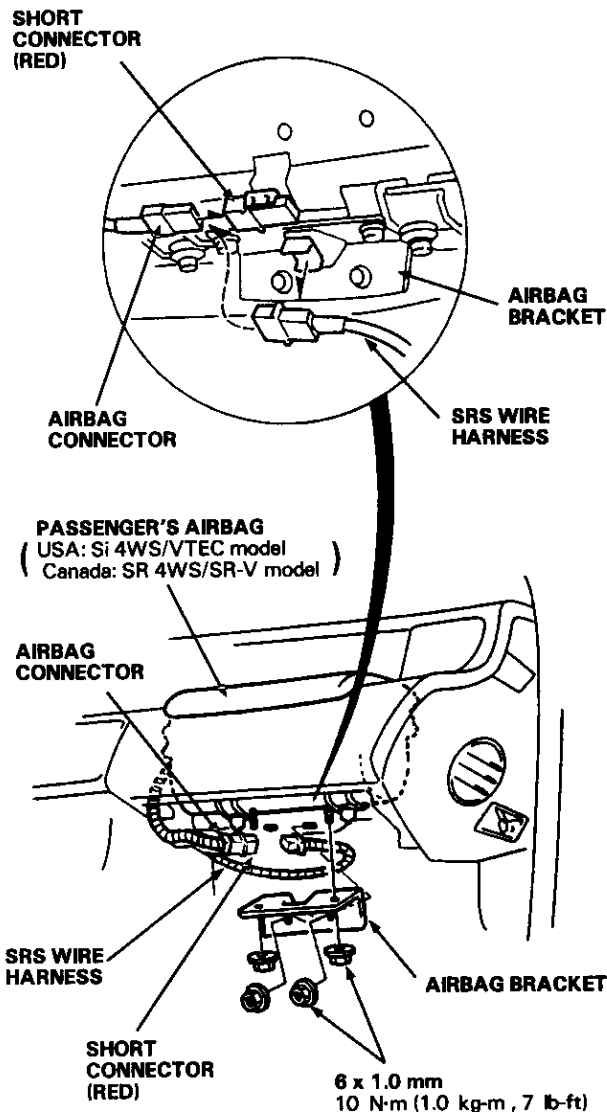

4. Disconnect the dashboard wire harness connectors and heater control cable.

NOTE:

Take care not to bend the heater control cable.

Driver's:

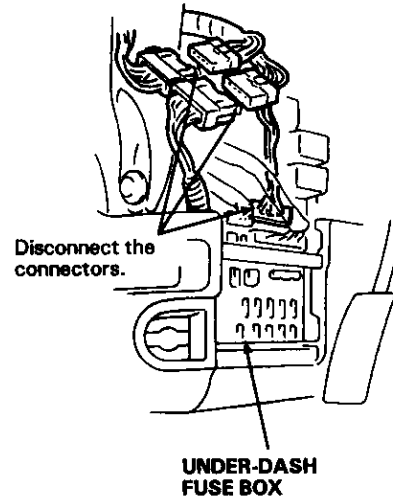

Center:

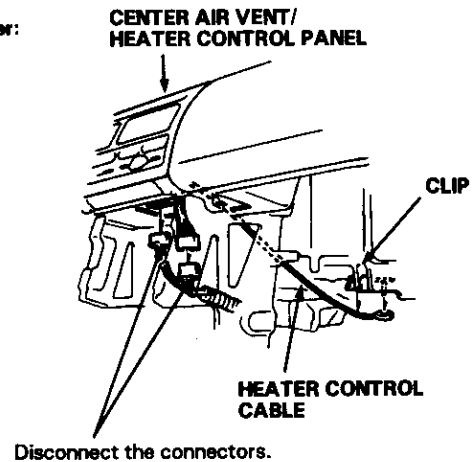

Passenger's:

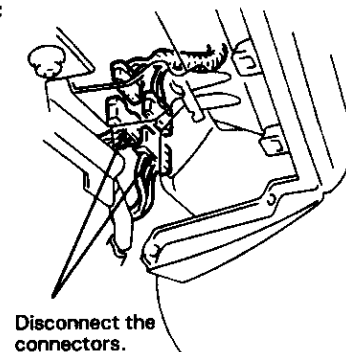



5. Remove the access panel on each end.
6. Remove the six mounting bolts, then lift and remove the dashboard.

CAUTION:

- Use protective tape on the bottom of the front pillar trim.
- When prying with a flat tip screwdriver, wrap it with protective tape to prevent damage.

NOTE:

Take care not to scratch the dashboard.

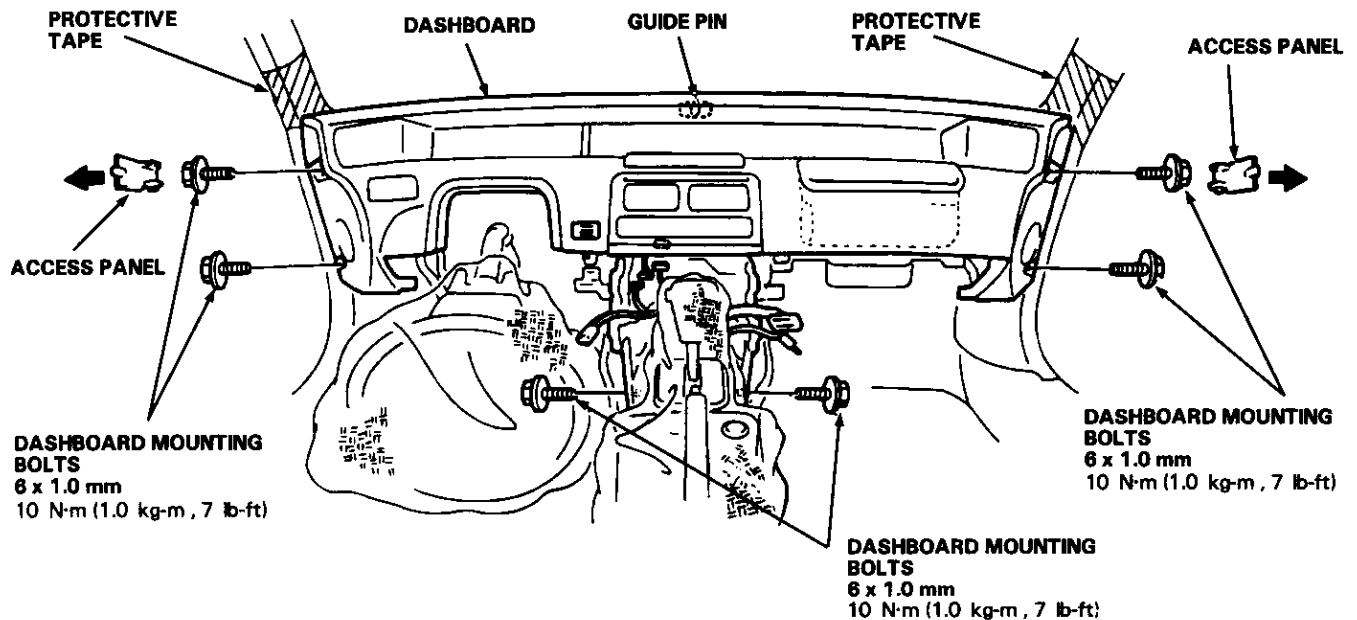

7. Installation is the reverse of the removal procedure.

NOTE:

- Make sure the dashboard fits onto the guide pin correctly.
- Before tightening the dashboard mounting bolts, make sure the dashboard wire harnesses are not pinched, and that dashboard is not interfering with the heater control cable.

Bumpers

Front Replacement

NOTE:

- An assistant is helpful when removing the front bumper.
- Take care not to scratch the front bumper.
- Open the hood.
- When removing the clips, loosen the screw, then remove the clips with a clip remover.

1. Remove the right and left front turn signal light and front side marker lights.

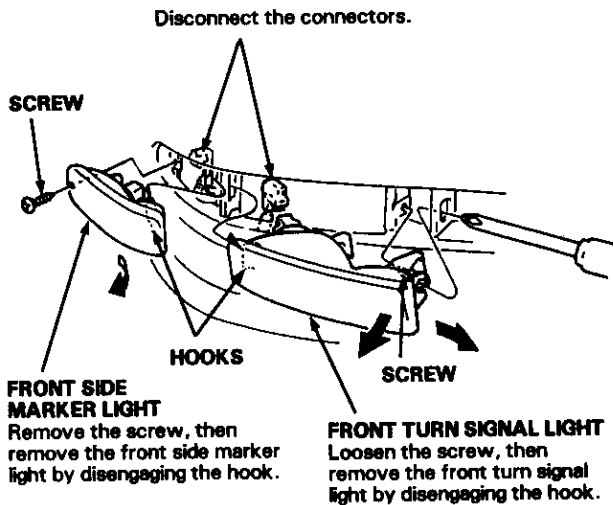

2. Remove the screw and lower mounting bolts on each side at the corner edge of the front bumper.

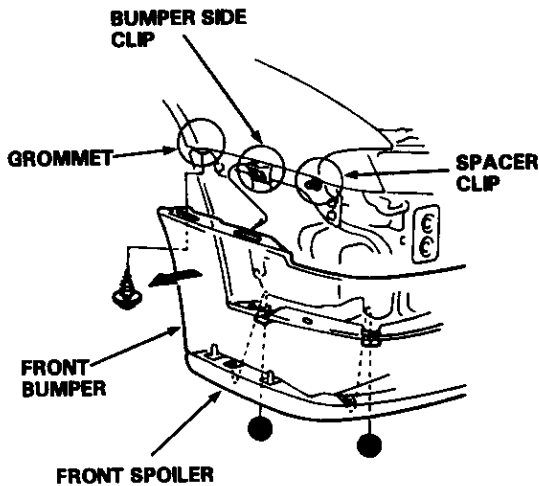

3. Remove the right and left upper mounting nuts from the engine compartment.

Right:

MOUNTING NUT
8 x 1.25 mm
22 N·m (2.2 kg·m, 16 lb-ft)

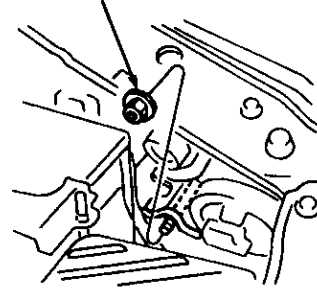

Left:

MOUNTING NUT
8 x 1.25 mm
22 N·m (2.2 kg·m, 16 lb-ft)

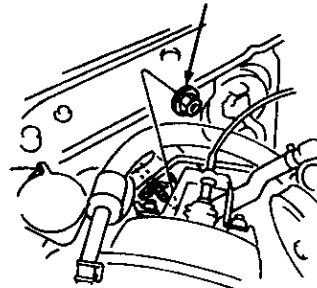

Bumper side clip locations:

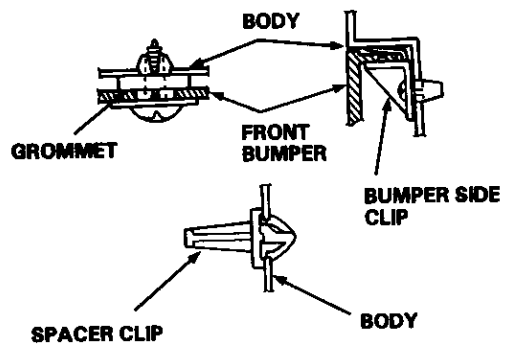



4. Remove the clips, screws and mounting bolts, then remove the front bumper as shown.

▶ : Clip locations

● : Bolt locations

6 x 1.0 mm

10 N·m (1.0 kg·m, 7 lb-ft)

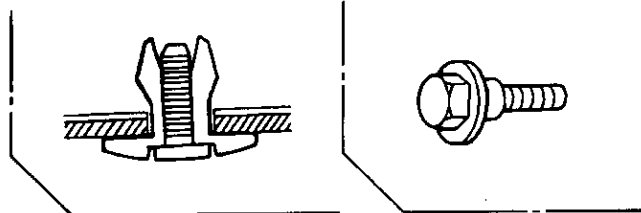

FRONT BUMPER

Pull back the rear edge of the front bumper on each side, then remove the front bumper by sliding it forward.

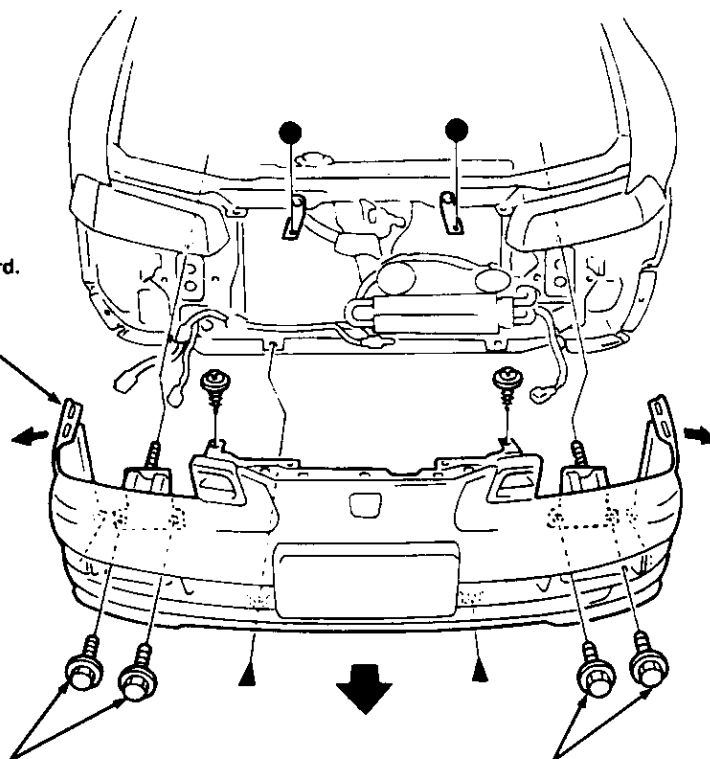

MOUNTING BOLTS

8 x 1.25 mm

22 N·m (2.2 kg·m, 16 lb-ft)

MOUNTING BOLTS

8 x 1.25 mm

22 N·m (2.2 kg·m, 16 lb-ft)

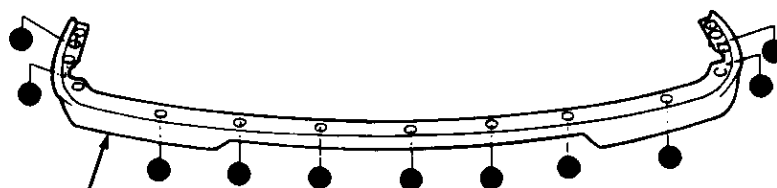

FRONT SPOILER

5. Installation is the reverse of the removal procedure.

Bumpers

Front Disassembly

If necessary, separate the front bumper, absorber and bumper beam.

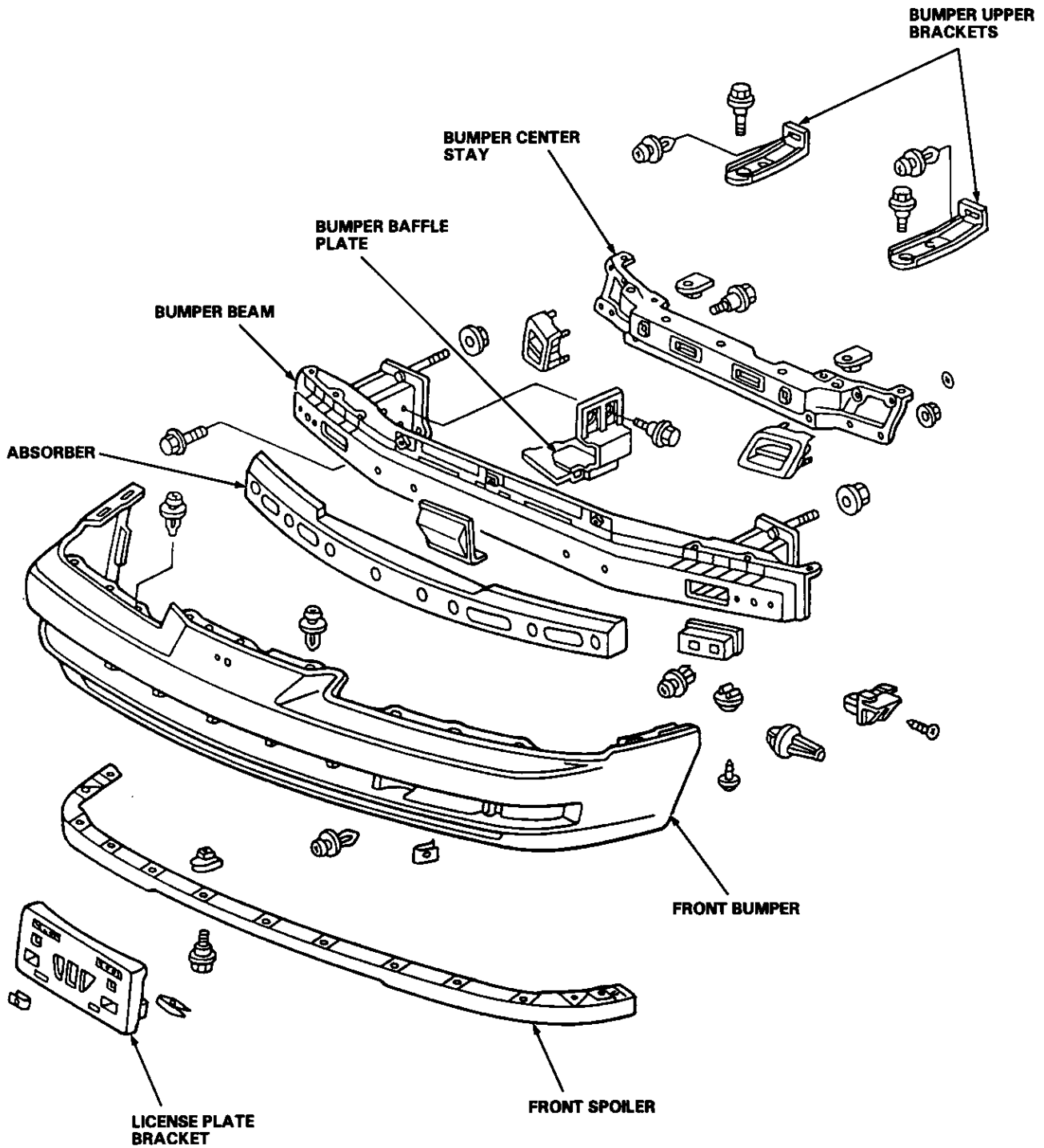



Rear Replacement

Disassemble in numbered sequence.

NOTE:

- An assistant is helpful when removing the rear bumper.
- Take care not to scratch the rear bumper.
- Open the trunk lid.

ACCESS CAPS

MOUNTING BOLTS
Peel back the trunk side panel (see page 20-37).

MOUNTING NUTS
First remove the rear trim panel (see page 20-37).

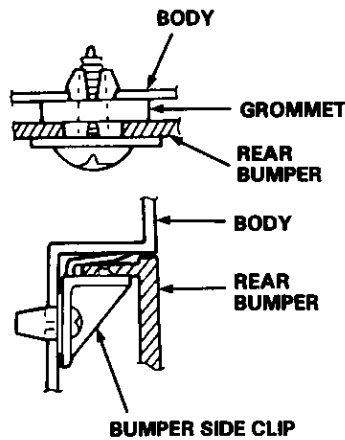
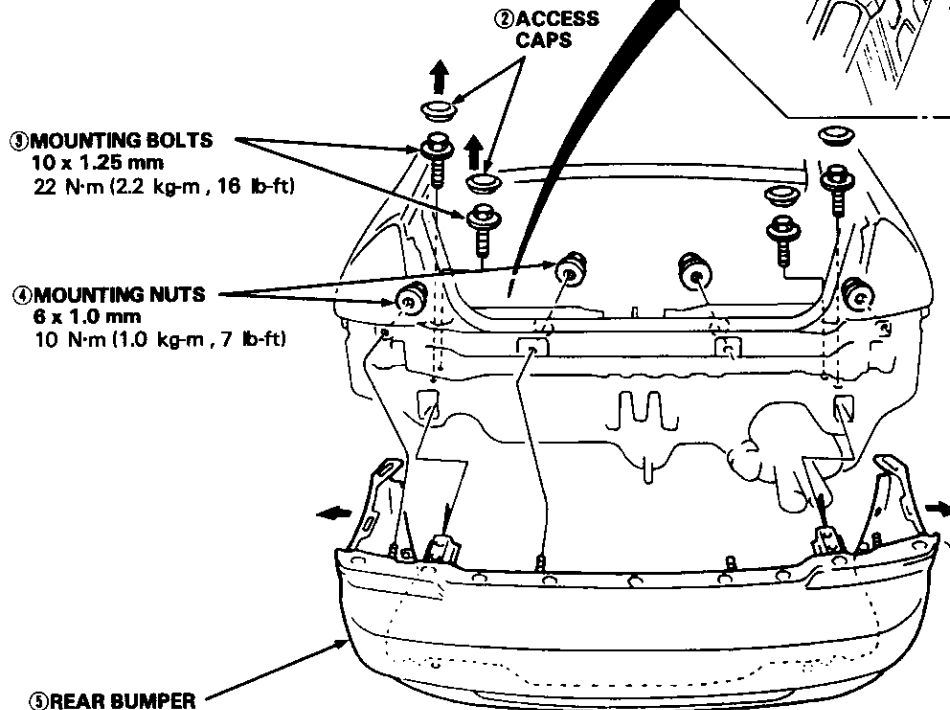

BUMPER SIDE CLIP

GROMMETS

① Remove the screws.

② Disconnect the side marker light connector.

REAR BUMPER

Installation is the reverse of the removal procedure.

Bumpers

Rear Disassembly

NOTE:

If necessary, separate the rear bumper, absorber and bumper beam.

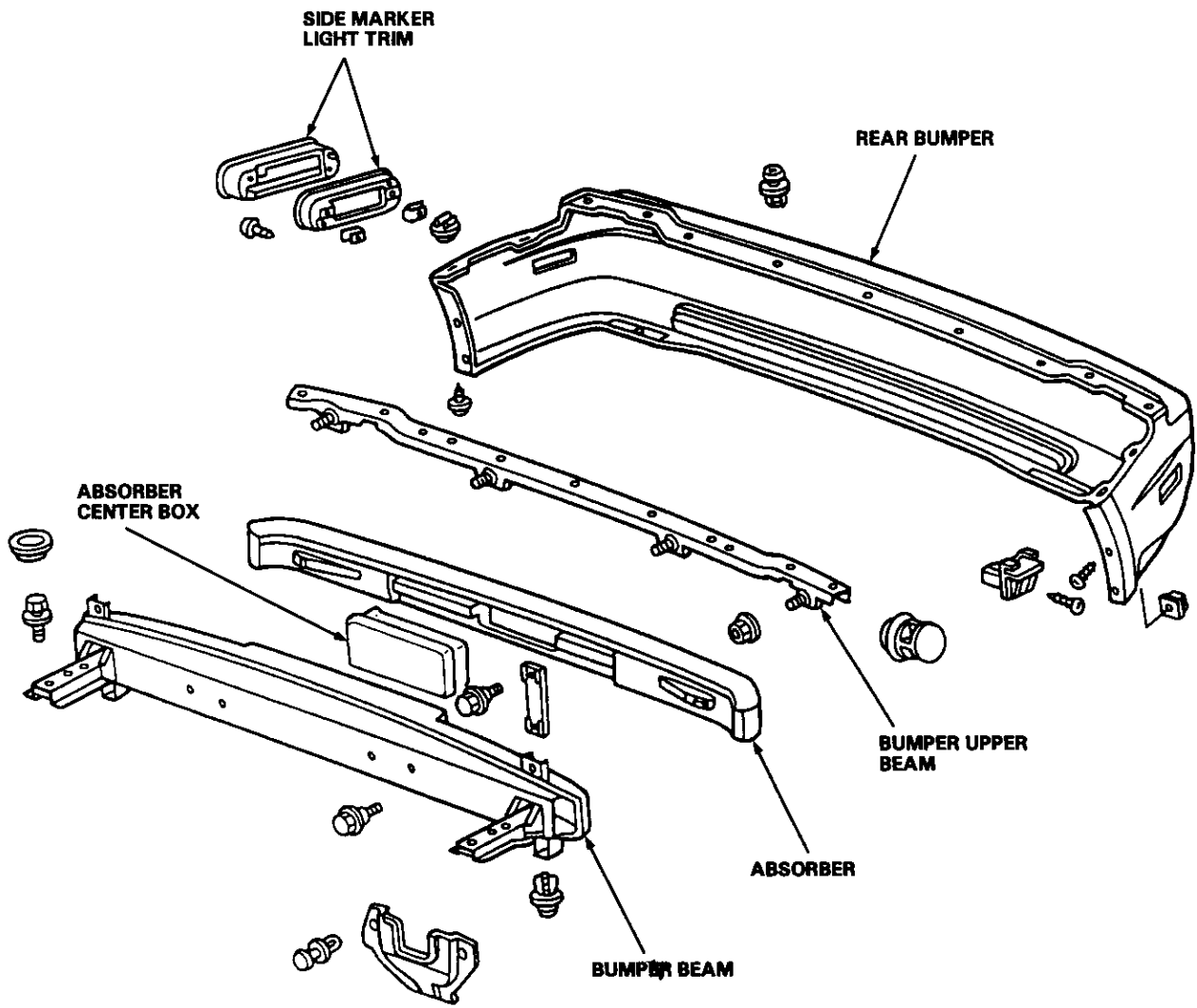



Hood

Replacement/Adjustment

NOTE:

- An assistant is helpful when removing the hood.
- Remove the air scoop (see section 23).

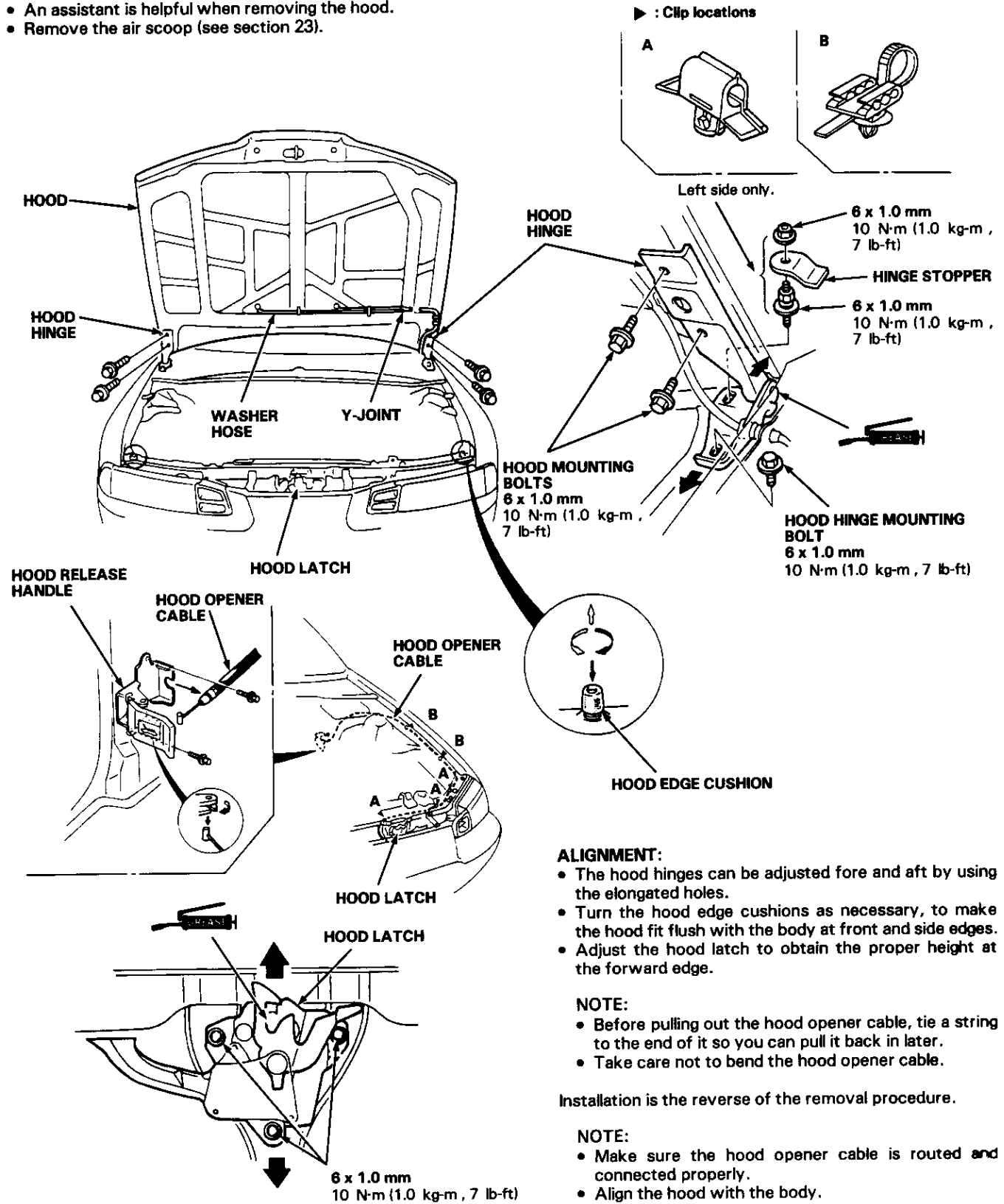

Trunk Lid

Replacement/Adjustment

NOTE:

- An assistant is helpful when removing the trunk lid.
- Before pulling out the wire harness and trunk lid opener cable, tie a string to the end of them so you can pull them back in when the trunk lid is reinstalled.

▶ : Clip locations

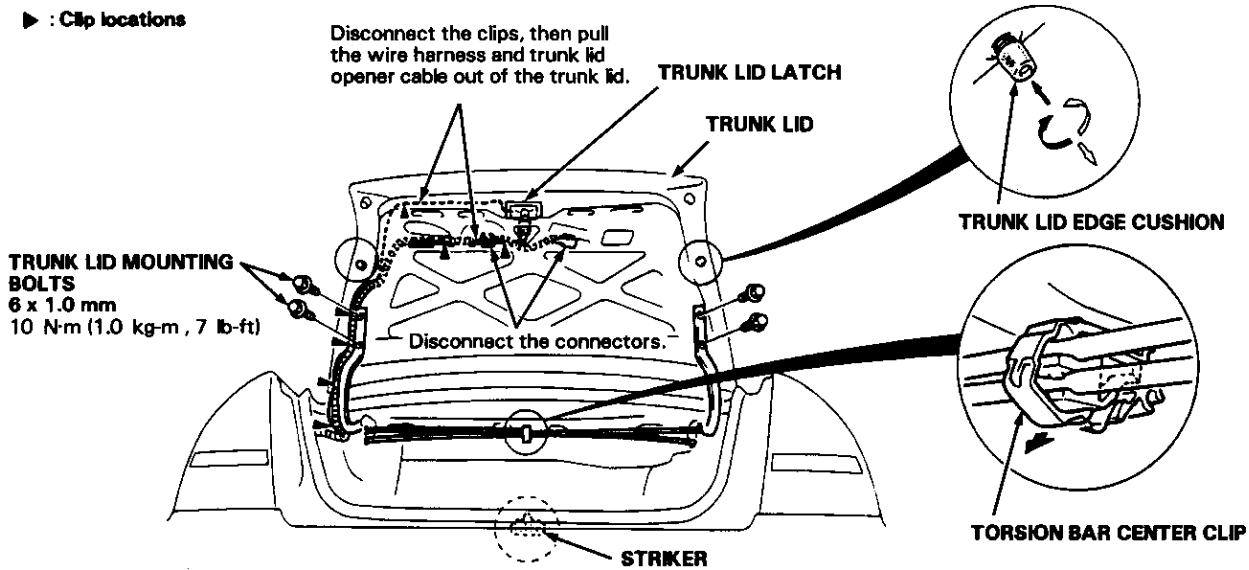

NOTE:

Remove the rear shelf (see page 20-37).

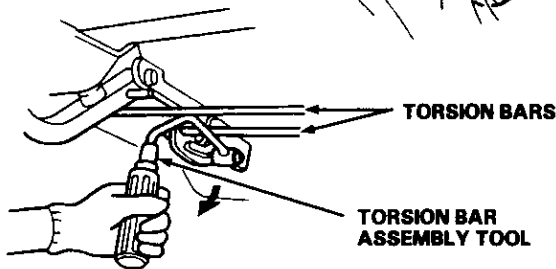
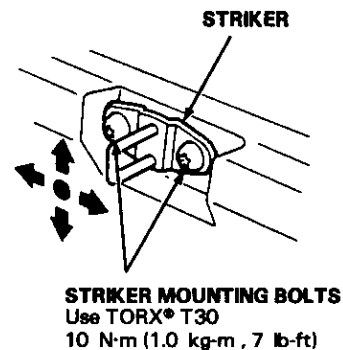
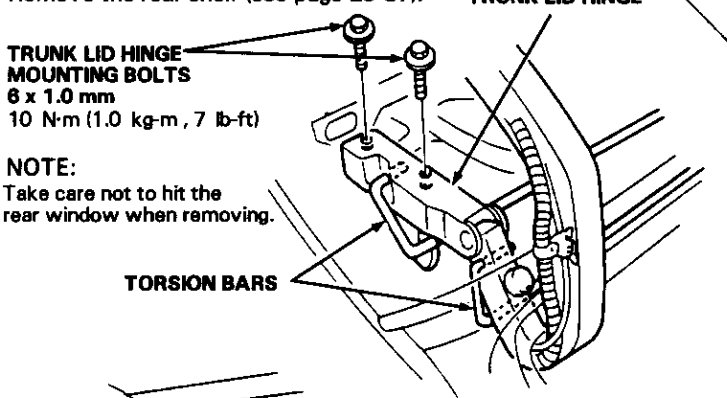

Adjust the torsion bars front or rear with the torsion bar assembly tool as shown.

- = Normal position
- ◐ = Higher position

ALIGNMENT:

- Adjust the trunk lid fit to the trunk lid opening by moving the striker.
- Turn the trunk lid edge cushions as necessary, to make the trunk lid fit flush with the body at the rear and side edges.
- The trunk lid hinges can be adjusted fore and aft by using the elongated holes.

Installation is the reverse of the removal procedure.

NOTE:

- Make sure the connectors are connected properly.
- Align the trunk lid with the body.



Trunk Lid Latch

Replacement

CAUTION:

When prying with a flat tip screwdriver, wrap it with protective tape to prevent damage.

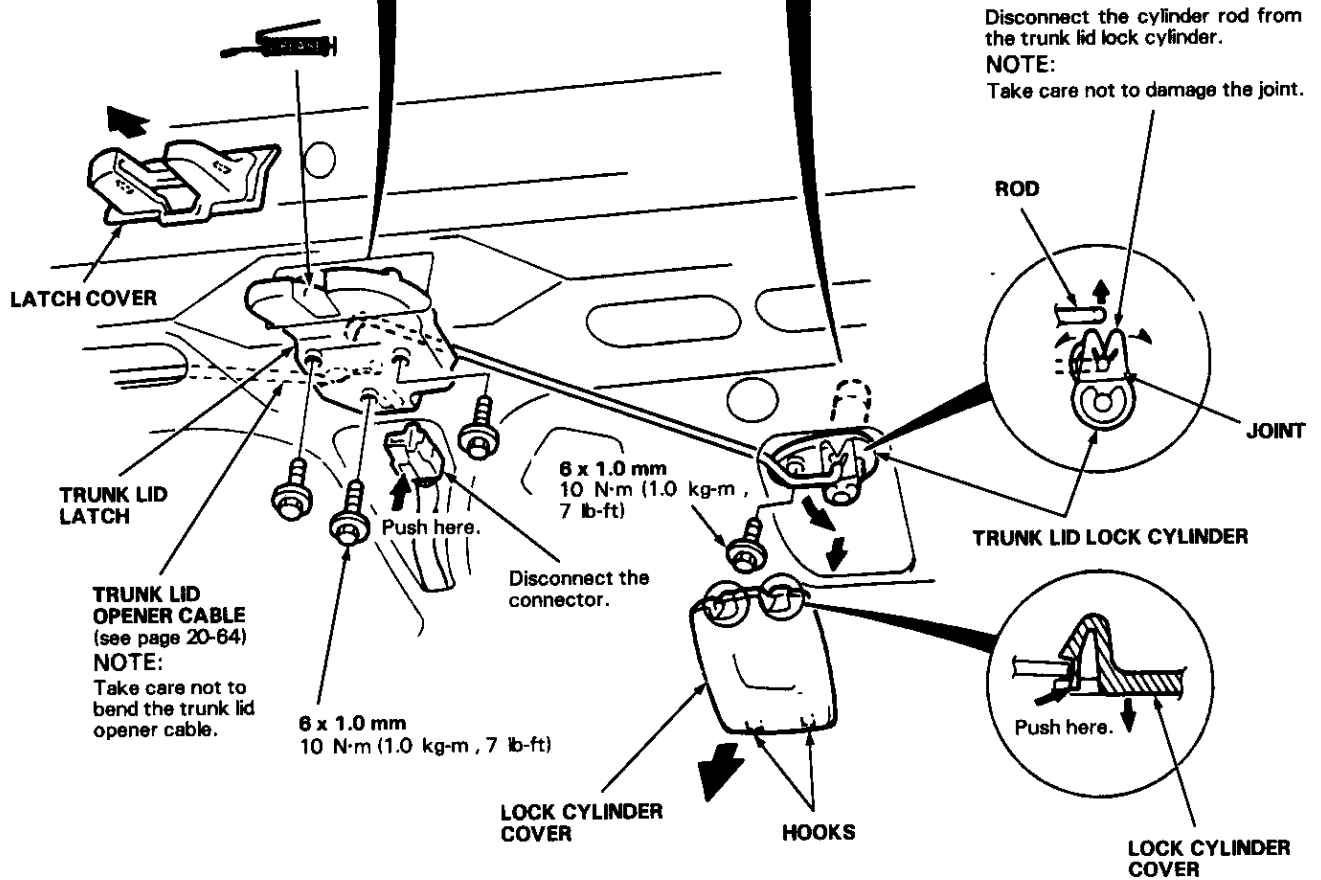
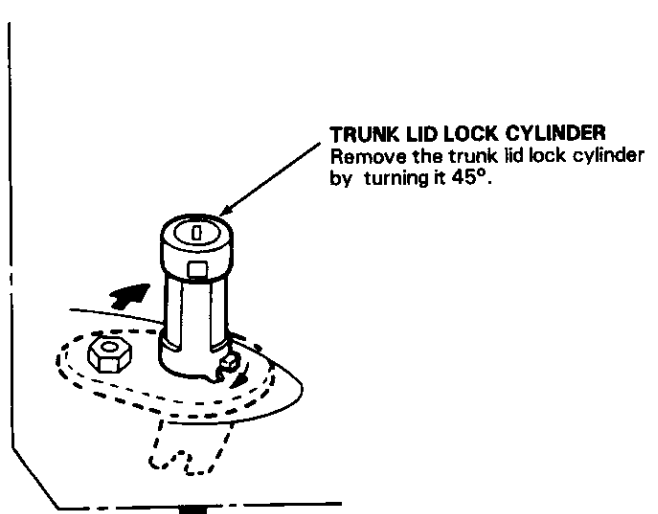
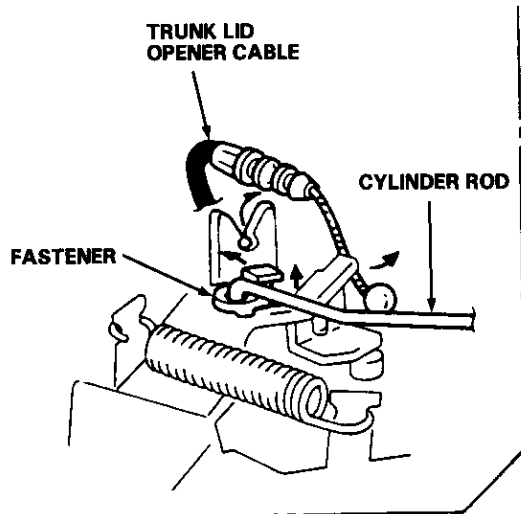

Installation is the reverse of the removal procedure.

NOTE:

- Make sure the trunk lid opener cable, cylinder rod and connector are connected properly.
- After installing, align the trunk lid with the striker (see page 20-64).

Opener Cables

Replacement

► : Clip locations

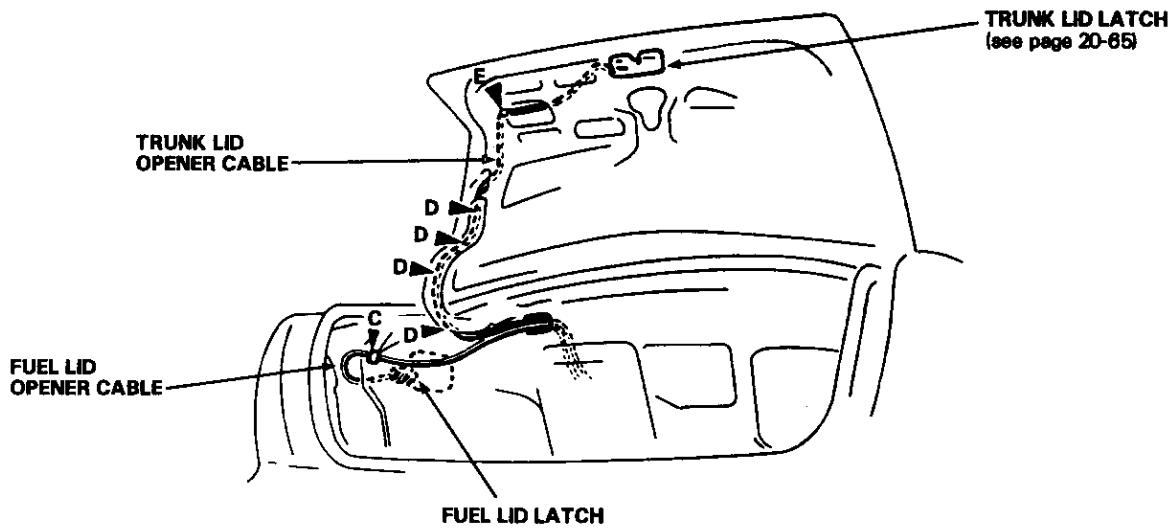
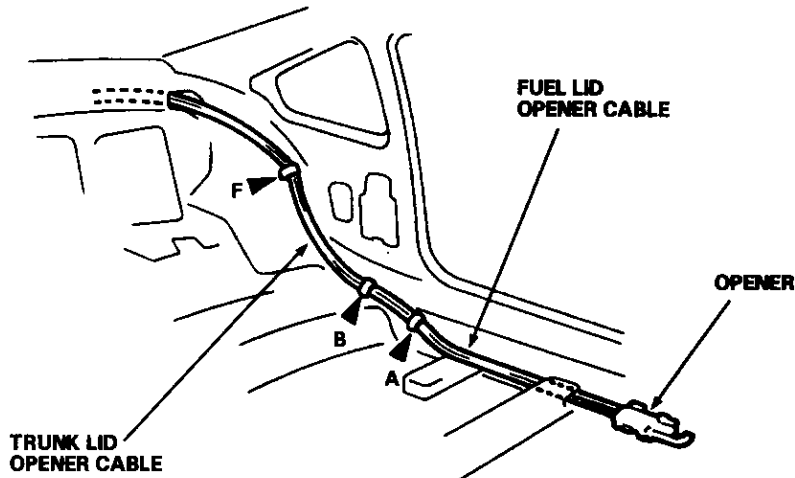
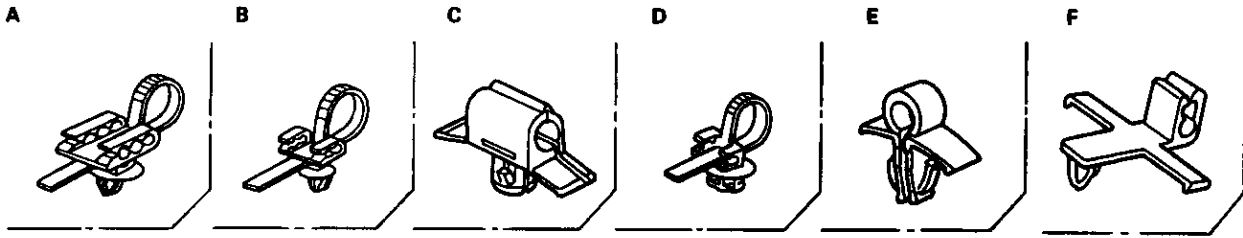

Installation is the reverse of the removal procedure.

NOTE:

- Take care not to bend the trunk lid and fuel lid opener cables.
- Make sure the trunk lid and fuel lid opener cables are routed and connected properly.



Opener and Fuel Lid Latch

Replacement

Opener:

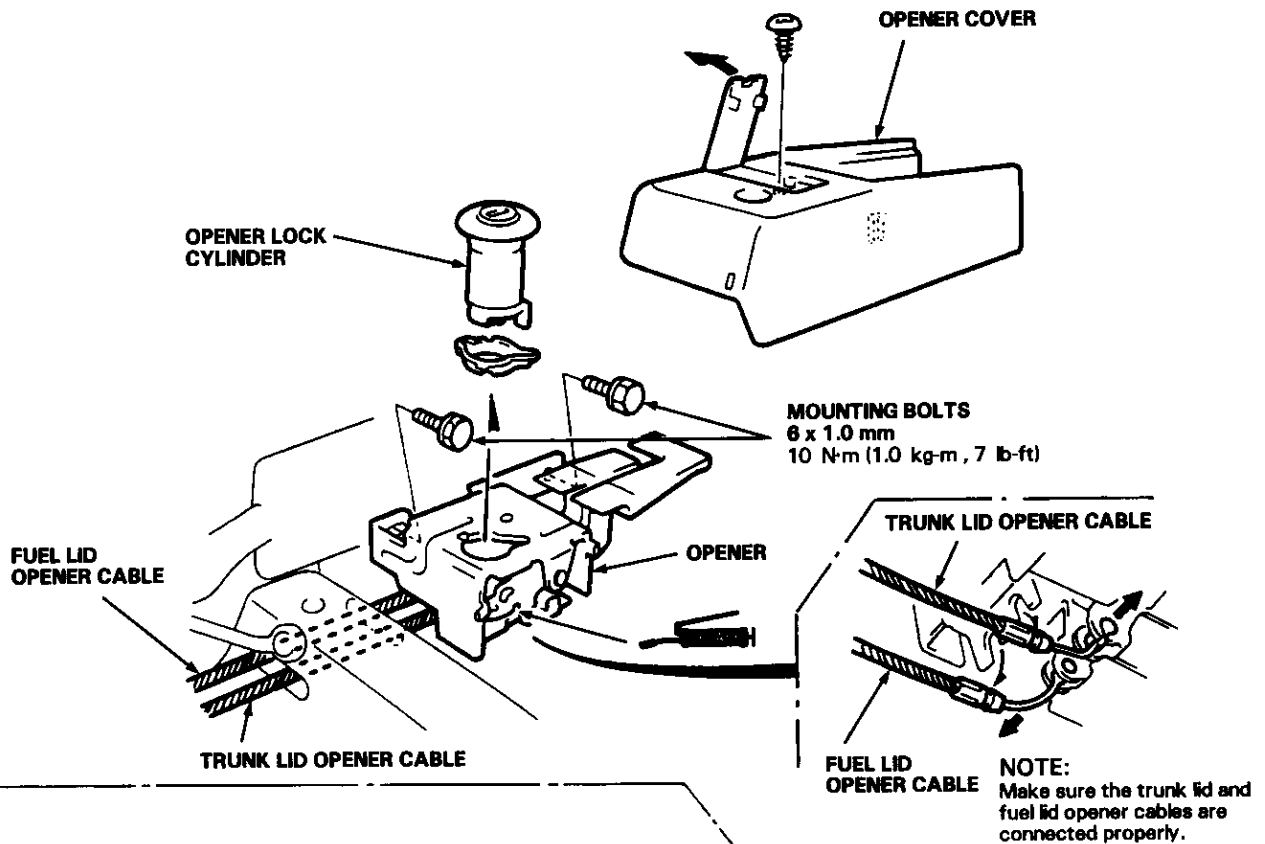

Fuel Lid Latch:

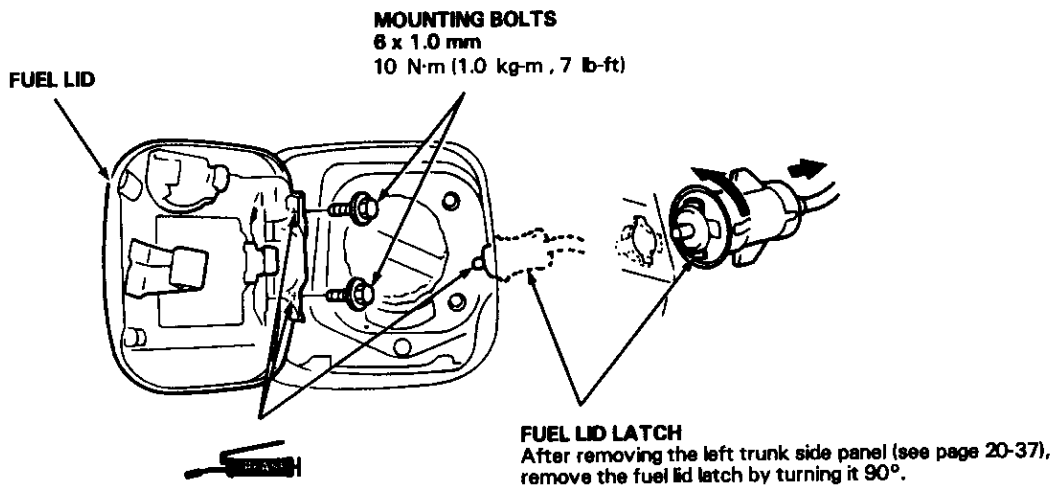

Installation is the reverse of the removal procedure.

NOTE:

- Take care not to bend the trunk lid and fuel lid opener cables.
- Make sure the fuel lid fits flush with the body.

Roof Molding/Side Sill Panel

Roof Molding Replacement

CAUTION:

When prying with a flat tip screwdriver, wrap it with protective tape to prevent damage.

NOTE:

Take care not to bend the roof molding.

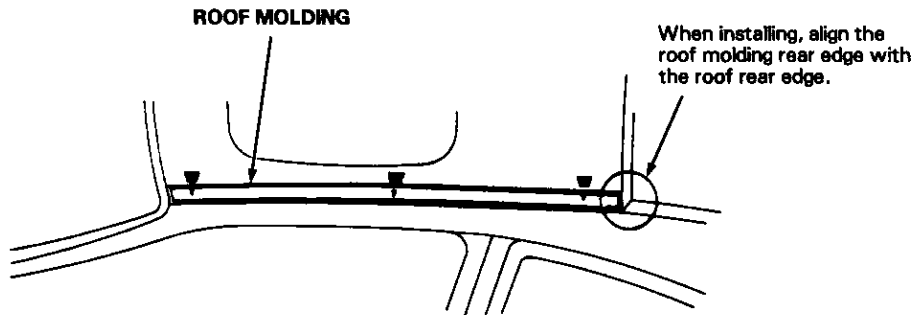

Installation is the reverse of the removal procedure.

NOTE:

If necessary, replace any damage clips.

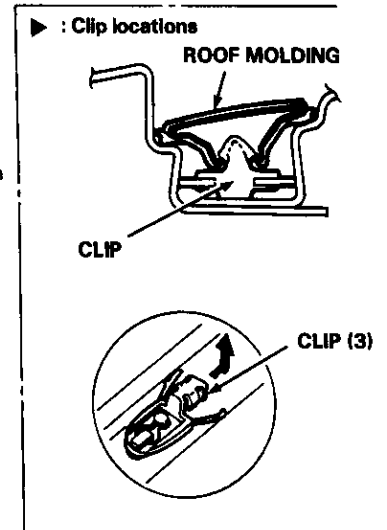

Side Sill Panel Replacement

: Clip locations

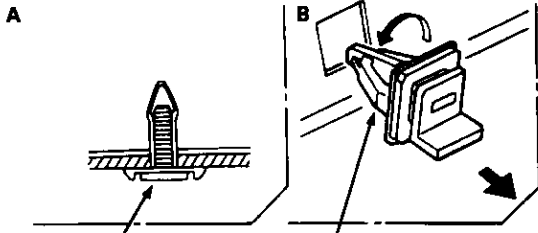

NOTE:
Loosen the screw, then remove the lower clip using a clip remover.

SIDE CLIP
Remove the side clips by turning them 45°.

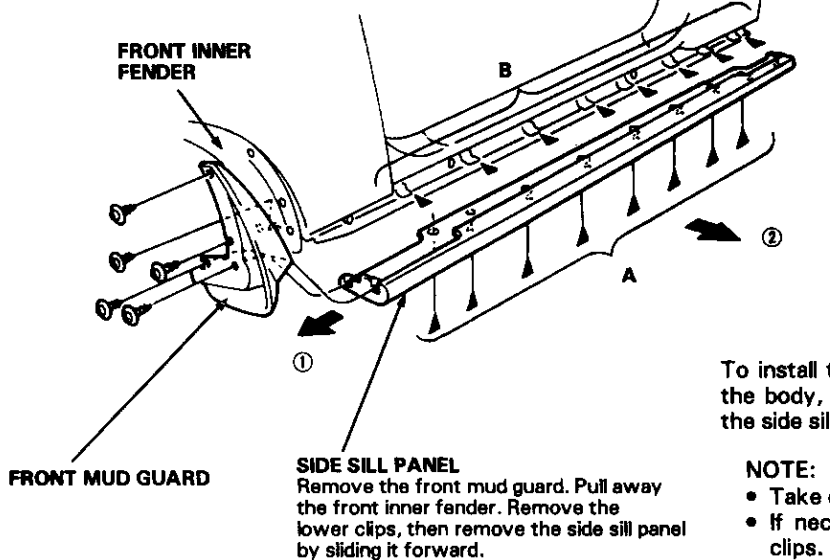

SIDE SILL PANEL
Remove the front mud guard. Pull away the front inner fender. Remove the lower clips, then remove the side sill panel by sliding it forward.

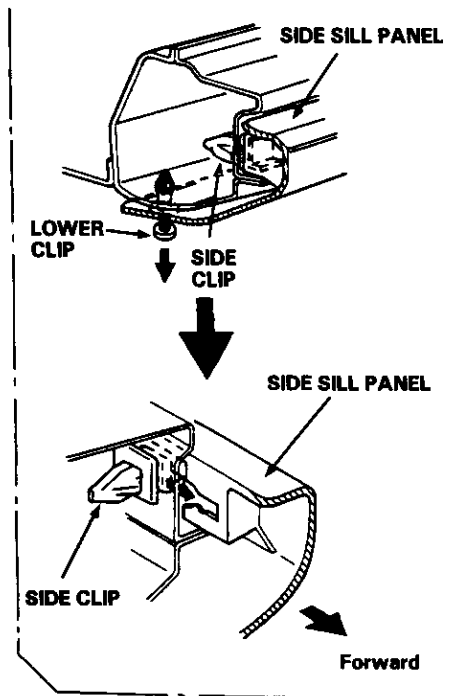

To install the side sill panel, remove the side clips from the body, install them on the side sill panel, then install the side sill panel on the car.

NOTE:

- Take care not to twist the side sill panel.
- If necessary, replace any damaged side and lower clips.

Hood Edge Protector/Rear Opening Weatherstrip/ License Plate Trim



Hood Edge Protector Replacement

► : Clip locations

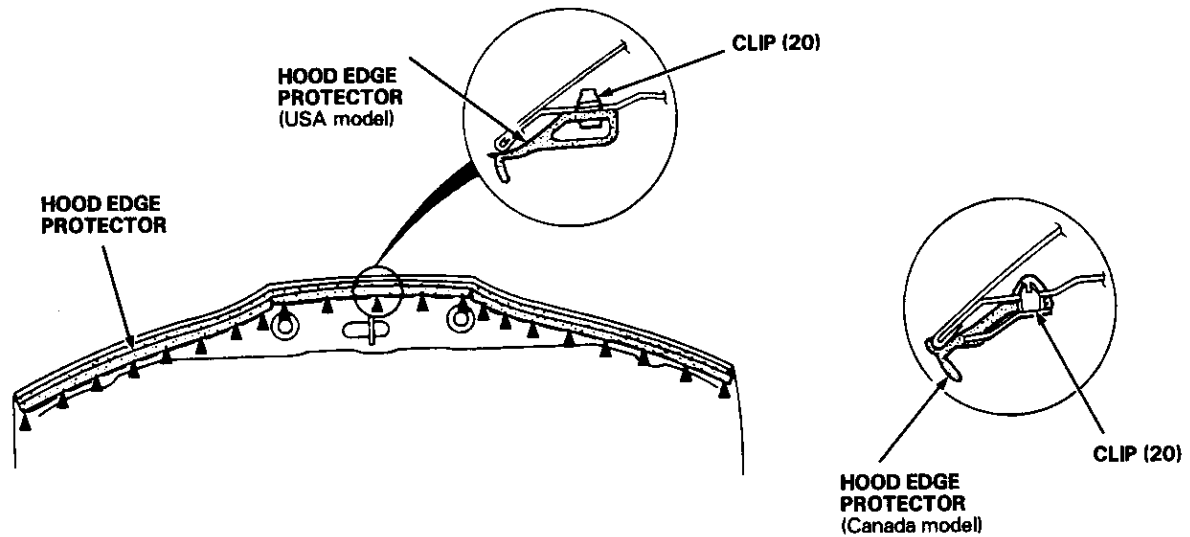

NOTE:
If necessary, replace any damaged clips.

Rear Opening Weatherstrip/License Plate Trim Replacement

NOTE:

- Take care not to damage the license plate trim.
- After installing the trunk lid weatherstrip, close the trunk lid, then check for water leaks.
- Do not use high pressure water.

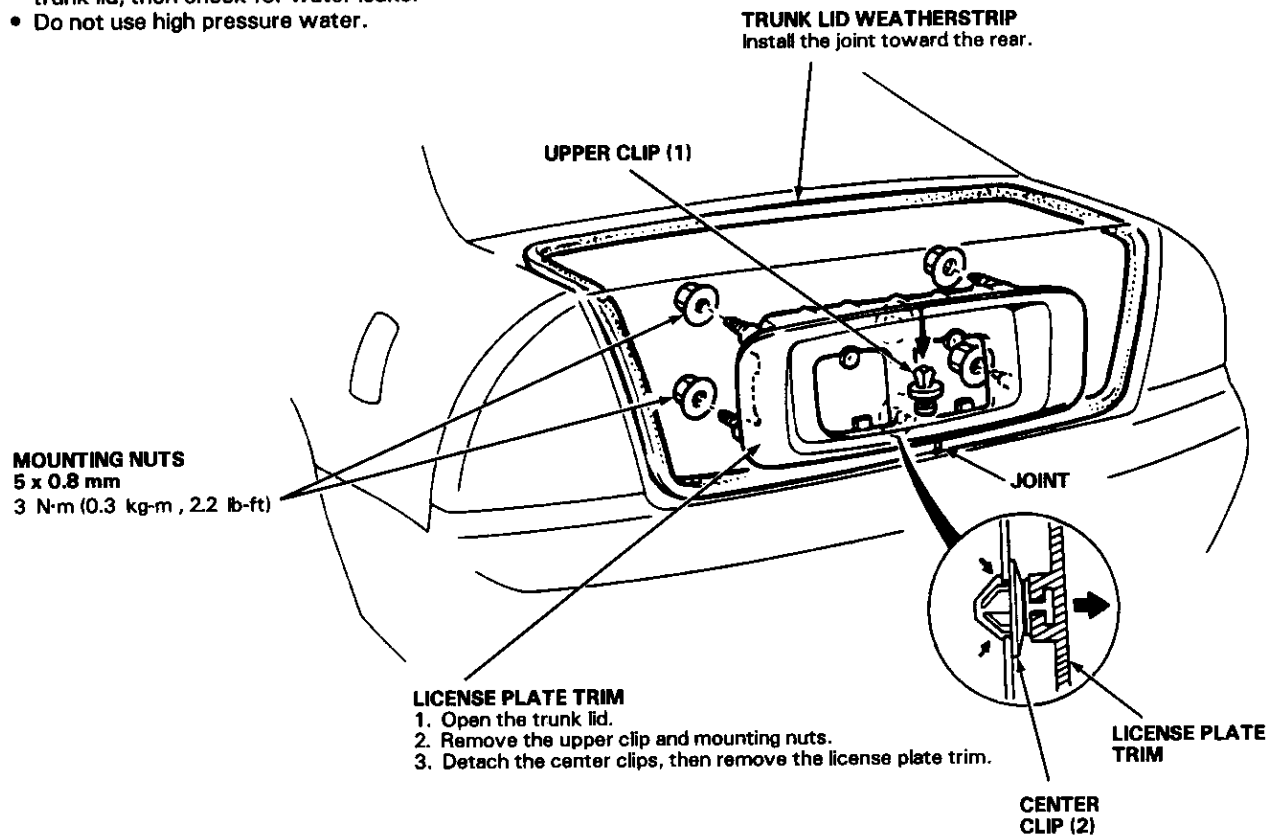

MOUNTING NUTS
5 x 0.8 mm
3 N·m (0.3 kg·m , 2.2 lb-ft)

LICENSE PLATE TRIM

1. Open the trunk lid.
2. Remove the upper clip and mounting nuts.
3. Detach the center clips, then remove the license plate trim.

LICENSE PLATE TRIM

CENTER CLIP (2)

Trunk Spoiler/Rear Emblem

Trunk Spoiler Replacement

CAUTION:

When removing the trunk spoiler, use protective tape or a shop towel on the trunk lid and trunk spoiler to prevent damage.

TRUNK SPOILER
 (USA: Si 4WS/VTEC model
 Canada: SR 4WS/SR-V model)

1. Open the trunk lid.
2. Remove the mounting bolts on both sides.
3. While holding the trunk spoiler, detach the stud bolts from the grommets. Lift and remove the trunk spoiler.

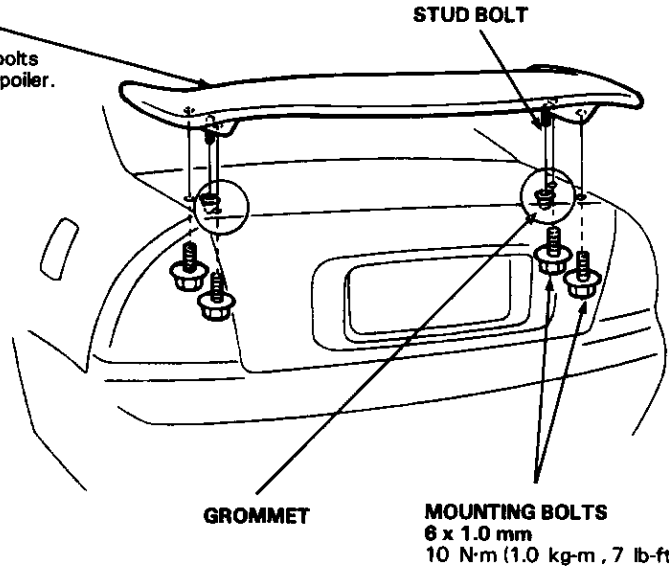

Installation is the reverse of the removal procedure.

NOTE:

Take care not to scratch the body.

Rear Emblem Installation

Attachment Points:

Unit: mm (in)

Apply the emblem where shown.

NOTE:

- Before applying, clean the body surface with a sponge dampened in alcohol.
- After cleaning, keep oil, grease or water from getting on the surface.
- When applying, make sure there are no wrinkles in the emblem.

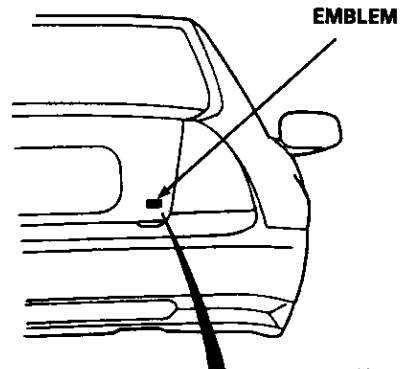

USA: Si 4WS model
 Canada: SR 4WS model

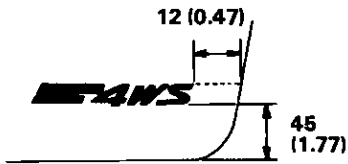

USA: VTEC model

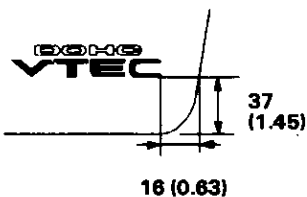

Canada: SR-V model

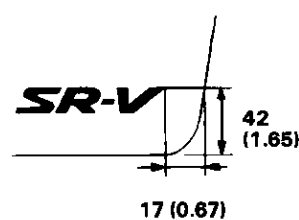

Canada: SR (Except 4WS model)

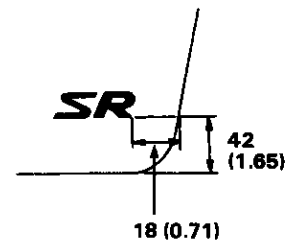



Sub-frame

Sub-frame torque sequence:

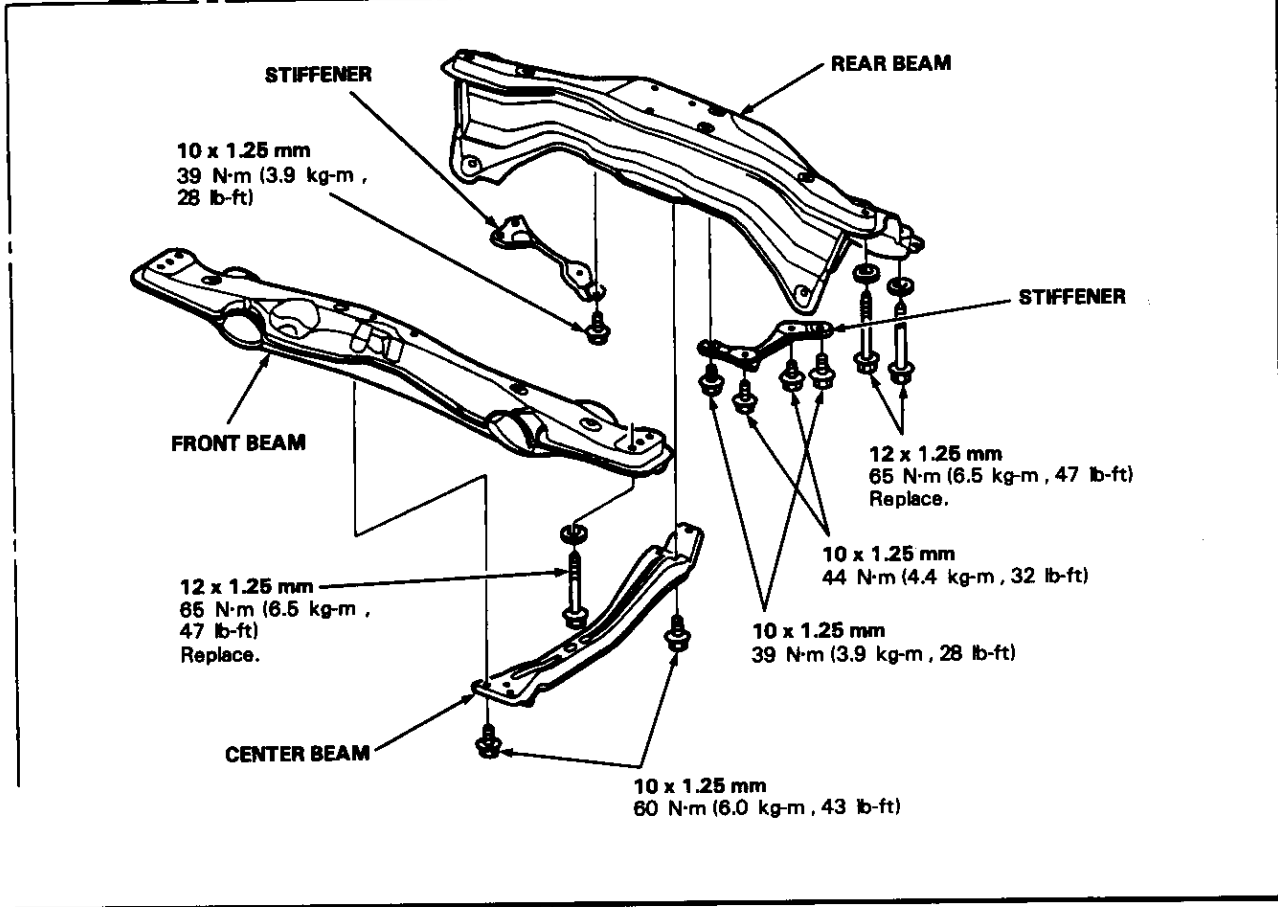
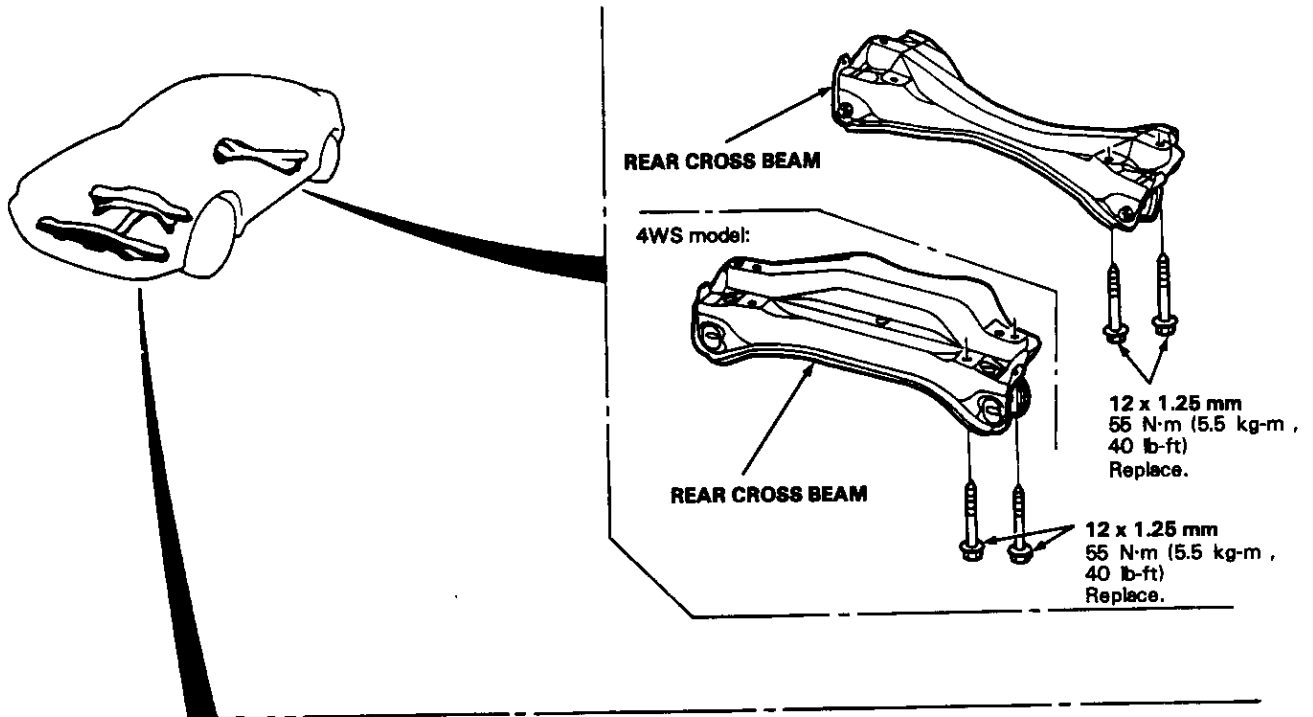

Frame Repair Chart

Unit: mm (in)

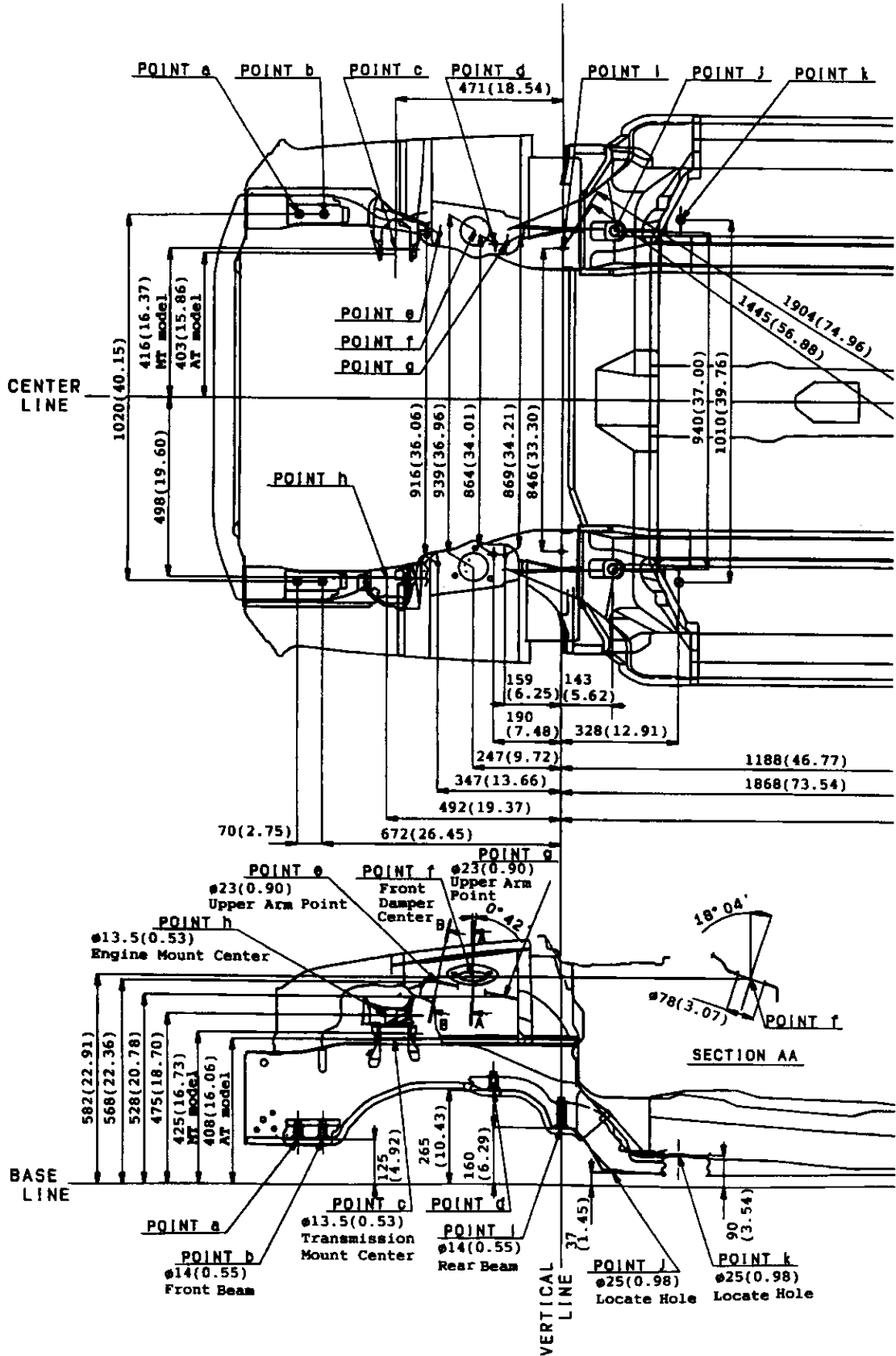

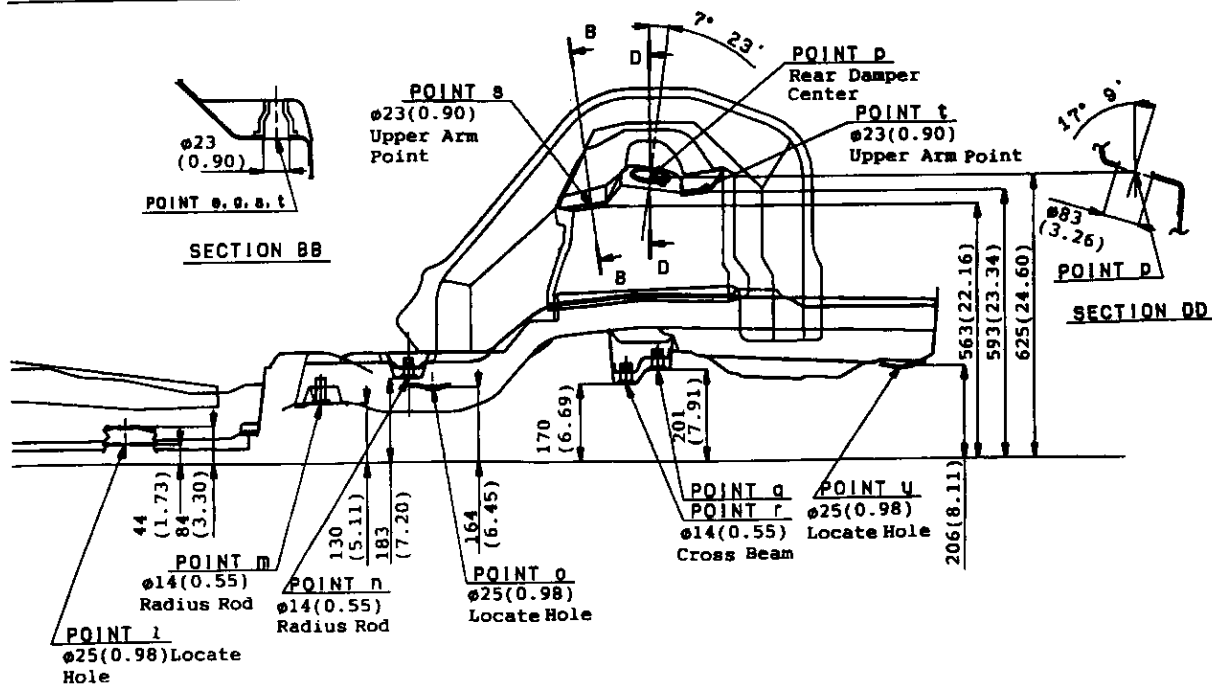
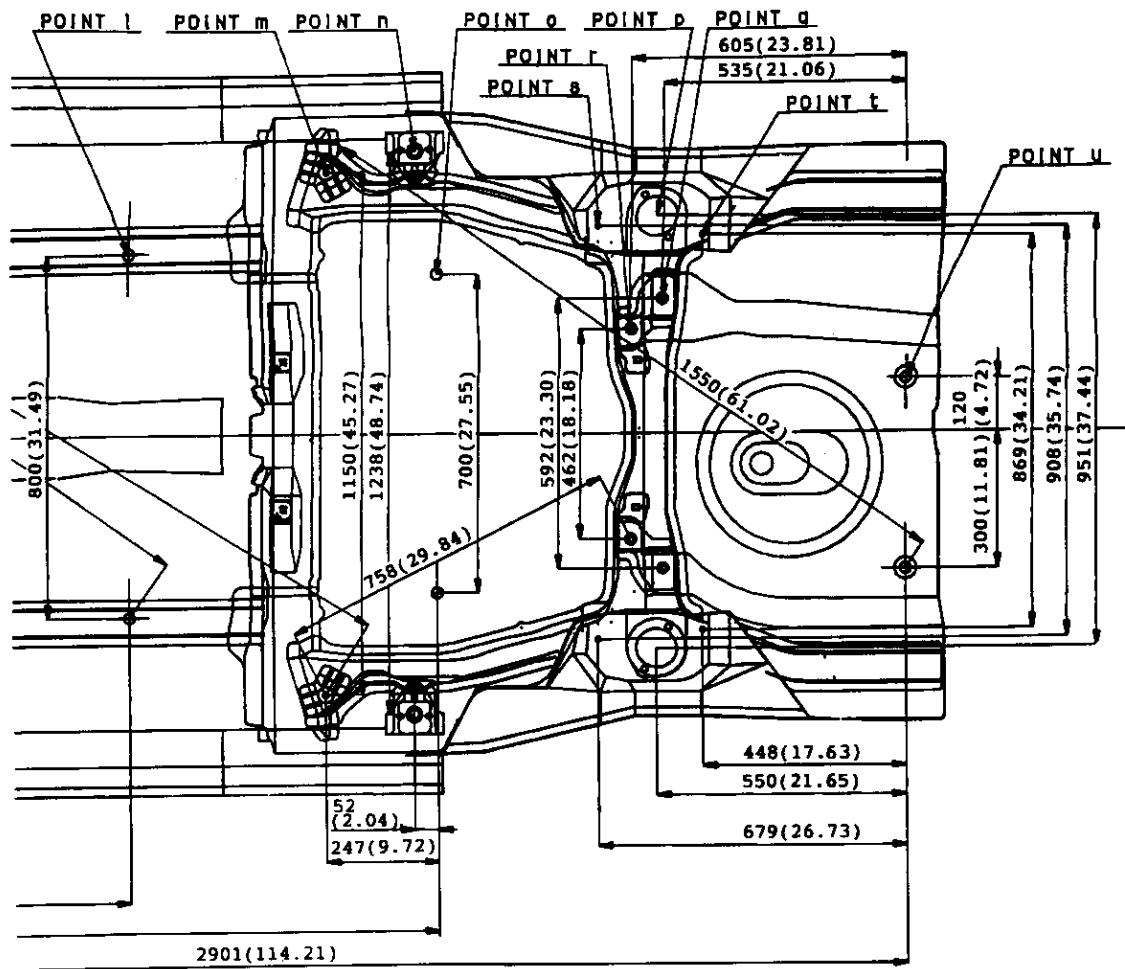

Heater and Air Conditioning

Heater	21-1
Air Conditioning	22-1

SUPPLEMENTAL RESTRAINT SYSTEM (SRS)

The Prelude SRS includes a driver's side airbag, located in the steering wheel hub. In addition, the Si 4WS, Si VTEC (USA) and SR 4WS, SR-V (Canada) models have a front passenger's airbag located in the dashboard above the glove box. Information necessary to safely service the SRS is included in this Service Manual. Items marked with an asterisk (*) in the contents of each section include, or are located near, SRS components. Servicing, disassembling or replacing these items will require special precautions and tools, and should therefore be done by an authorized Honda dealer.

WARNING

- To avoid rendering the SRS inoperative, which could lead to personal injury or death in the event of a severe frontal collision, all maintenance must be performed by an authorized Honda dealer.
- Improper maintenance, including incorrect removal and installation of the SRS, could lead to personal injury caused by unintentional activation of the airbag.
- All SRS electrical wiring harnesses are covered with yellow outer insulation. Related components are located in the steering column, center console, dash, and dashboard lower panel. Do not use electrical test equipment on these circuits.

NOTE: The radio may have a coded theft protection circuit. Be sure to get the customer's code number before

- Disconnecting the battery.
- Removing the No. 43 (10 A) fuse in the under-hood fuse/relay box.
- Removing the radio.

After service, reconnect power to the radio and turn it on. When the word "CODE" is displayed, enter the customer's 5-digit code to restore radio operation.



Heater

Illustrated Index	21-2
Heater Door Positions	21-3
Circuit Diagram	21-5
Troubleshooting	
Symptom Chart	21-6
Heater Control Panel Input/Output Signals	21-7
Flowchart	
Blower Motor Speed	21-8
Blower Motor	21-10
Mode Control Motor	21-13
Recirculation Control Motor	21-15
*Blower Unit	
Replacement	21-17
Overhaul	21-18
*Heater Unit	
Replacement	21-19
Overhaul	21-21
Heater Linkage Adjustment	21-22
Heater Control Panel	
Replacement	21-22
Overhaul	21-23
Heater Control Cables	
Heater Valve Cable Adjustment	21-24
Air Mix Control Cable Adjustment	21-24
Mode Control Motor	
Test	21-25
Replacement	21-25
Recirculation Control Motor	
Test	21-26
Replacement	21-26
Heater Fan Switch	
Test	21-27
Relay	
Test	21-27
Mode Control Switch	
Test	21-28
Recirculation Control Switch	
Test	21-28

*: Read SRS precautions before working in these areas.



Illustrated Index

CAUTION:

- All SRS electrical wiring harnesses are covered with yellow outer insulation.
- Before disconnecting the SRS wire harness, install the short connector(s) on the airbag(s) (see page 23-294).
- Replace the entire affected SRS harness assembly if it has an open circuit or damaged wiring.

NOTE: The radio may have a coded theft protection circuit. Be sure to get the customer's code number before.

- Disconnecting the battery.
- Removing the No. 43 (10 A) fuse in the under-hood fuse/relay box.
- Removing the radio.

After service, reconnect power to the radio and turn it on.

When the word "CODE" is displayed, enter the customer's 5-digit code to restore radio operation.

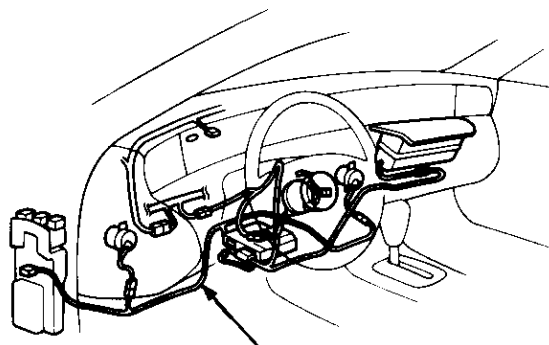

SRS MAIN HARNESS

BLOWER UNIT
Replacement, page 21-17
Overhaul, page 21-18

BLOWER RESISTOR
Test, page 21-8

HEATER UNIT
Replacement, page 21-19
Overhaul, page 21-21

RECIRCULATION CONTROL MOTOR
Test, page 21-26
Replacement, page 21-26

MODE CONTROL SWITCH
Test, page 21-28

A/C SWITCH
Test, page 22-23

MODE CONTROL MOTOR
Test, page 21-25
Replacement, page 21-25

RECIRCULATION CONTROL SWITCH
Test, page 21-28

HEATER FAN SWITCH
Test, page 21-27

AIR MIX CONTROL CABLE
Adjustment, page 21-24
Replacement, page 21-23

TEMPERATURE CONTROL LEVER
(Adjustment, see AIR MIX CONTROL CABLE)

HEATER CONTROL PANEL
Replacement, page 21-22
Overhaul, page 21-23

Heater Door Positions



(VENT)



HOT



COOL

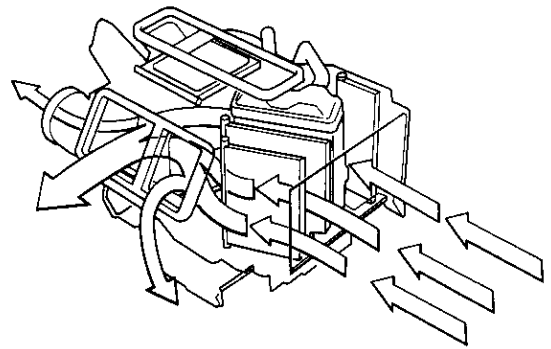
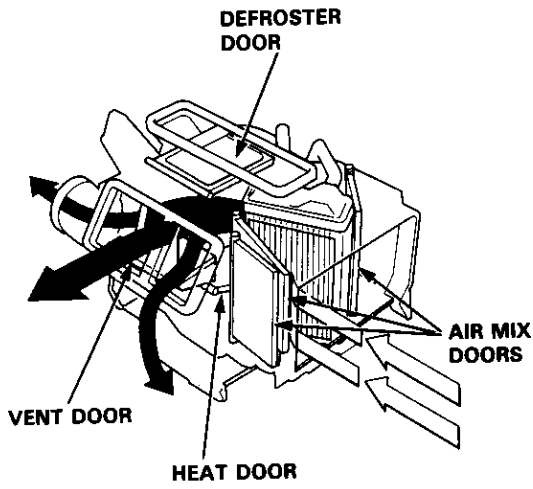

(HEAT/VENT)

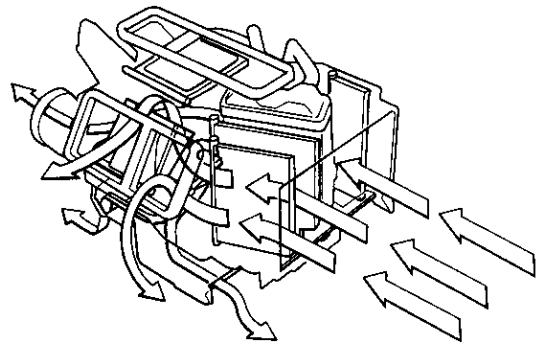
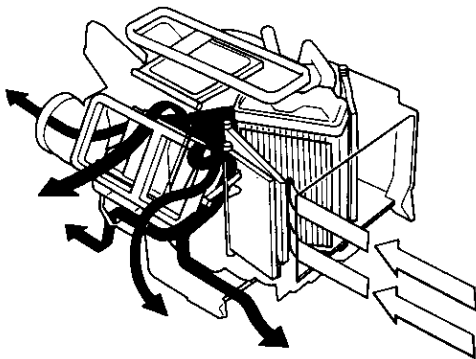

(cont'd)

Heater Door Positions (cont'd)



HOT

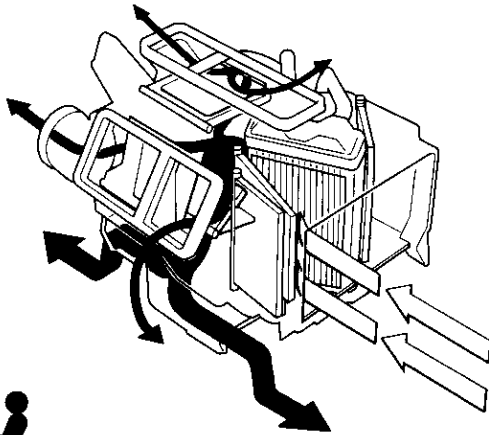

COOL

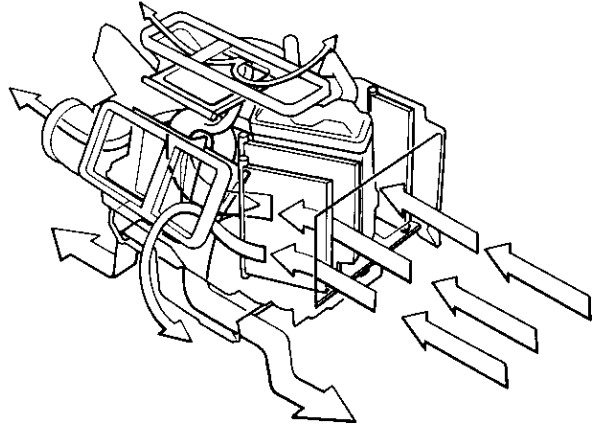

(HEAT/DEF)

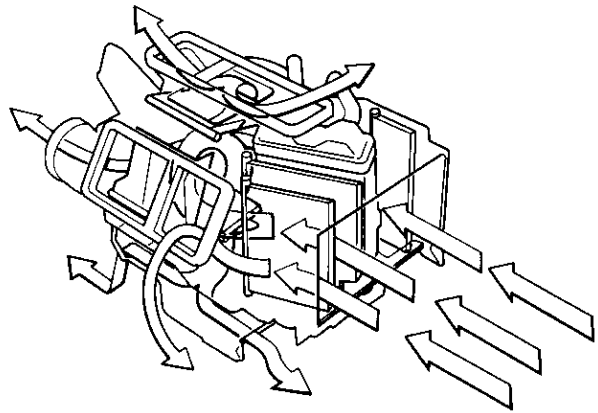
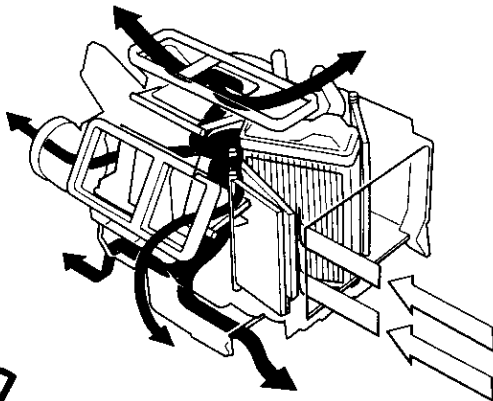

(DEF)

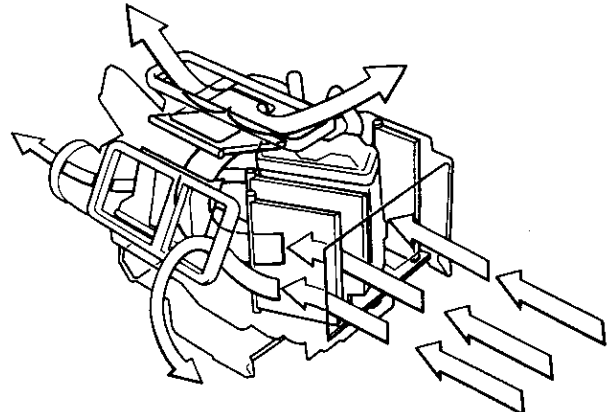
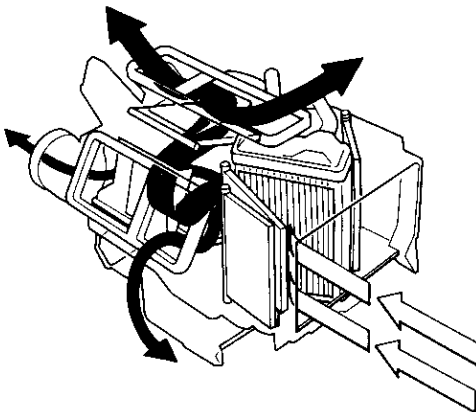

Circuit Diagram

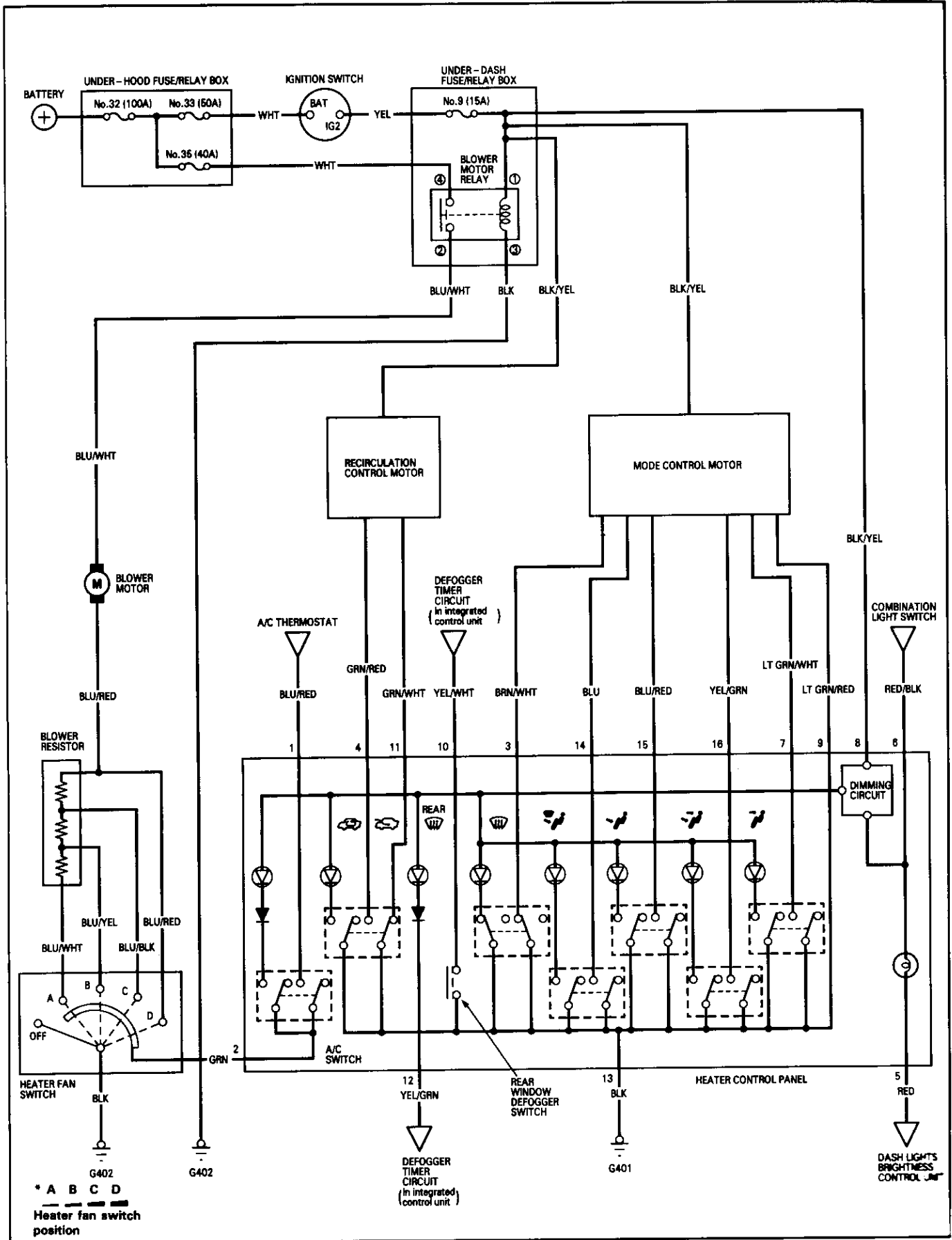

Troubleshooting

Symptom Chart

NOTE: Check the engine coolant level and allow the engine to warm up before troubleshooting.

SYMPTOM		REMEDY
No hot air flow	Blower motor does not run at all.	Follow the flowchart (see page 21-10).
	Blower motor runs	Check for the following: <ul style="list-style-type: none"> • Clogged heater duct • Clogged blower outlet • Clogged heater valve • Faulty air mix door • Heater valve cable adjustment (see page 21-24). • Air mix control cable adjustment (see page 21-24) • Faulty thermostat (see section 10) • Clogged evaporator (With air conditioning) • Frozen evaporator (With air conditioning)
Hot air flow is low	Blower motor runs, but one or more speeds are inoperative	Follow the flowchart (see page 21-8).
	Blower runs properly	Check for the following: <ul style="list-style-type: none"> • Clogged heater duct • Clogged heater outlet • Incorrect door position
Mode control motor does not run, or one or more modes are inoperative.		Follow the flowchart (see page 21-13).
Recirculation control doors do not change between FRESH and REC.		Follow the flowchart (see page 21-15).



Heater Control Panel Input/Output Signals

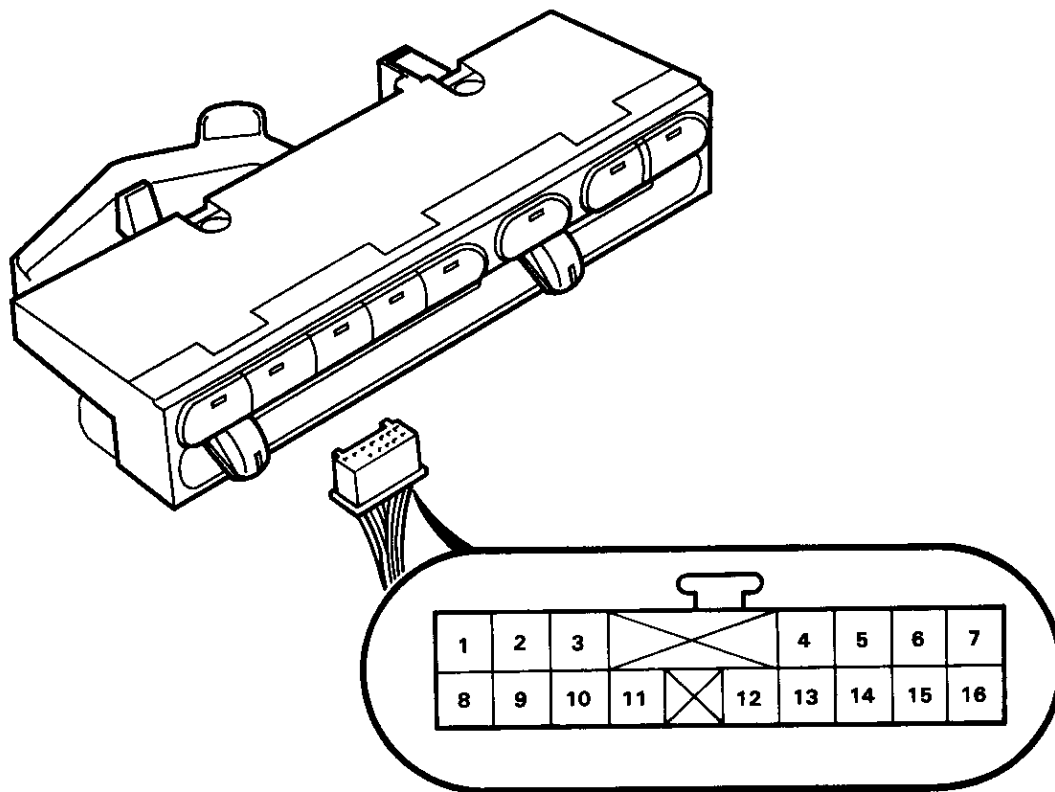

View from wire side.

No.	Wire Color	Signal	No.	Wire Color	Signal
1	BLU/RED	A/C THERMOSTAT	9	LT GRN/RED	MODE CONTROL MOTOR (GND)
2	GRN	A/C SWITCH	10	YEL/WHT	DEFOGGER TIMER (SWITCH)
3	BRN/WHT	DEF	11	GRN/WHT	FRESH
4	GRN/RED	RECIRCULATION	12	YEL/GRN	DEFOGGER TIMER (INDICATOR)
5	RED	BRIGHTNESS CONTROL UNIT	13	BLK	GROUND
6	RED/BLK	COMBINATION LIGHT SWITCH	14	BLU	HEAT/DEF
7	LT GRN/WHT	VENT	15	BLU/RED	HEAT
8	BLK/YEL	IG2	16	YEL/GRN	HEAT/VENT

Troubleshooting

Flowchart — Blower Motor Speed

Blower motor runs, but one or more speeds are inoperative.

Turn the ignition switch ON, and the heater fan switch OFF.

Does the blower motor run?

YES **B** To page 21-9

NO

Turn the ignition switch OFF.

Disconnect the blower resistor 5P connector.

Measure resistance between the No. 1 and No. 5 terminals of the blower resistor.

Is there approx. 2.5 Ω ?

NO **Replace the blower resistor.**

YES

Reconnect the blower resistor 5P connector.

Remove the stereo radio/cassette player (see section 23).

Disconnect the heater fan switch 7P connector.

Turn the ignition switch ON.

At the heater fan switch 7P connector, ground each of these wires individually in the following order:
—BLU/WHT
—BLU/YEL
—BLU/BLK
—BLU/RED

A
To page 21-9

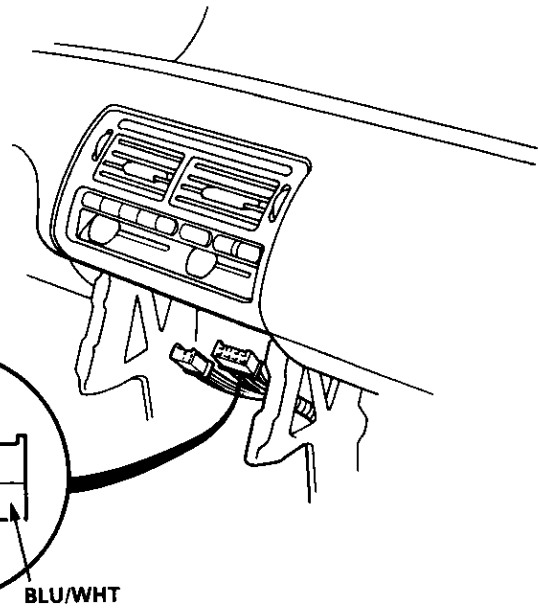
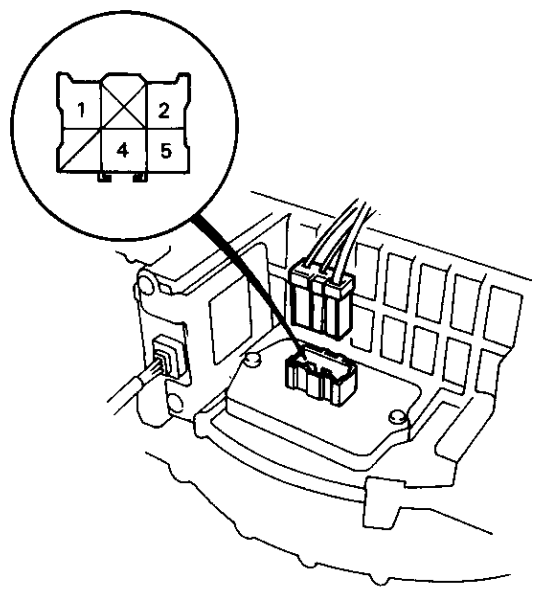

View from wire side.



From page 21-8

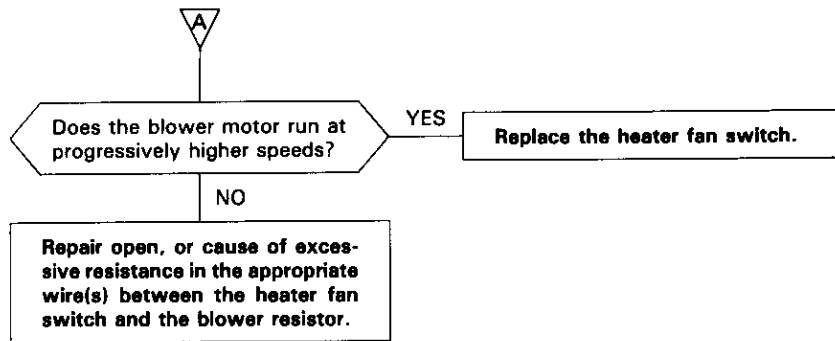

From page 21-8

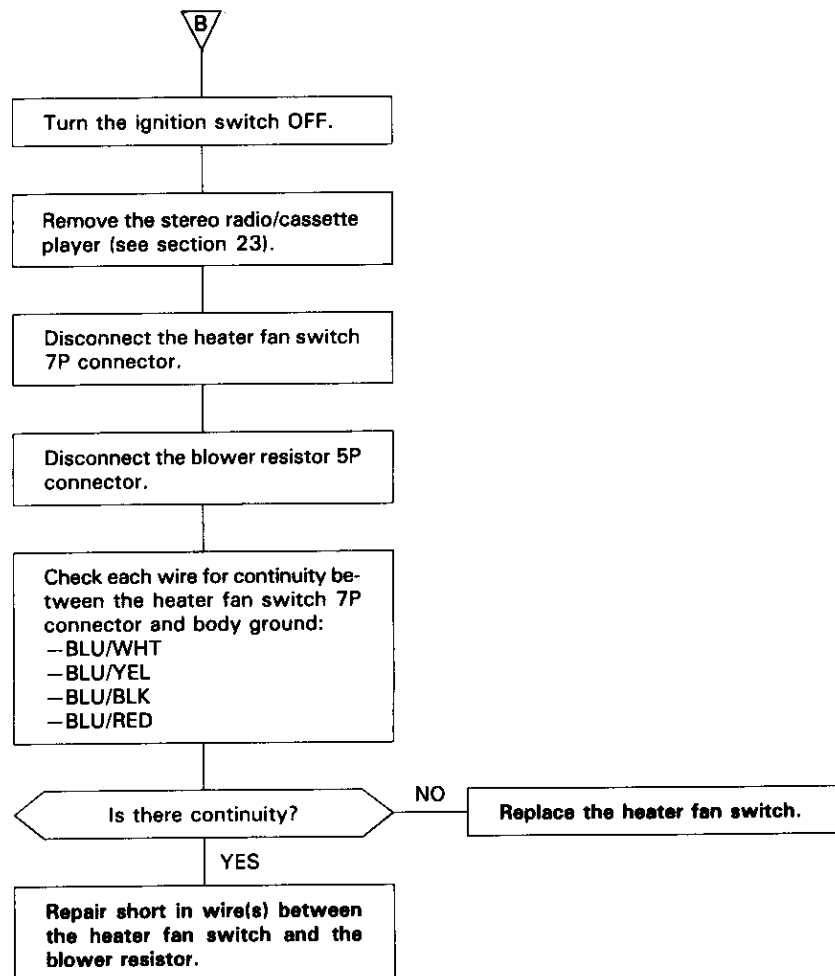

Troubleshooting

Flowchart — Blower Motor

Blower motor does not run at all.

Check No. 9 (15 A) fuse in the under-dash fuse/relay box and No. 35 (40 A) fuse in the under-hood fuse/relay box.

Are the fuses OK?

NO

Replace the fuse(s).

YES

Turn the ignition switch ON.

At the blower motor 2P connector, connect the BLU/RED wire terminal to the body ground using a jumper wire.

Does the blower motor run?

YES

To page 21-11

NO

Disconnect the blower motor 2P connector and measure voltage between the BLU/WHT wire terminal (+) and body ground (-).

Is there battery voltage?

YES

Replace the blower motor.

NO

Turn the ignition switch OFF.

Remove the blower motor relay and test it (see page 21-27).

Is the relay OK?

NO

Replace the blower motor relay.

YES

Measure voltage between the No. ④ terminal (+) and body ground (-).

Is there battery voltage?

NO

Repair open in the WHT wire between the No. 35 (40 A) fuse in the under-hood fuse/relay box and No. ④ terminal.

YES

To page 21-12

View from wire side.

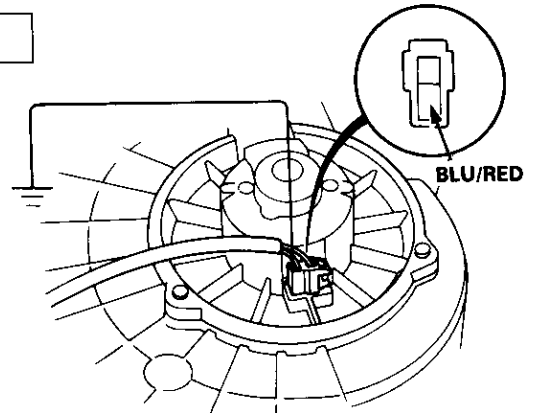

BLU/WHT (+)

View from wire side.

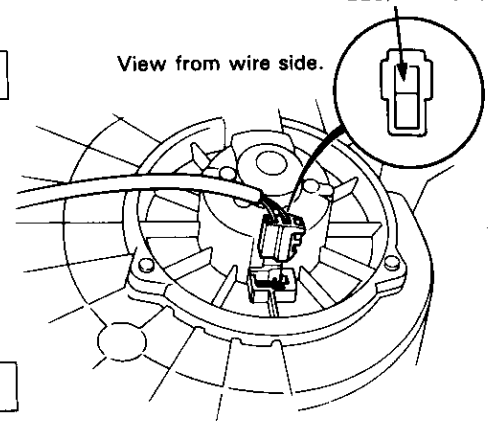

UNDER-DASH FUSE/RELAY BOX

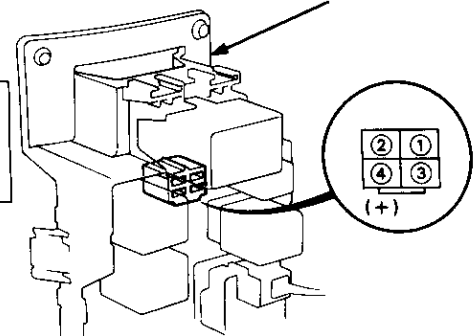



From page 21-10

Turn the ignition switch OFF.

Remove the stereo radio/cassette player (see section 23).

Disconnect the heater fan switch 7P connector.

Turn the ignition switch ON.

Measure voltage between the BLU/RED wire terminal (+) and body ground (-).

Is there battery voltage?

NO

Repair open in the BLU/RED wire between the blower motor and heater fan switch.

YES

Turn the ignition switch OFF.

Check for continuity in the BLK wire between the heater fan switch and body ground.

Is there continuity?

NO

Check for an open in the BLK wire between the heater fan switch and body ground. If the wire is OK, check for poor ground at G402.

YES

Replace the heater fan switch.

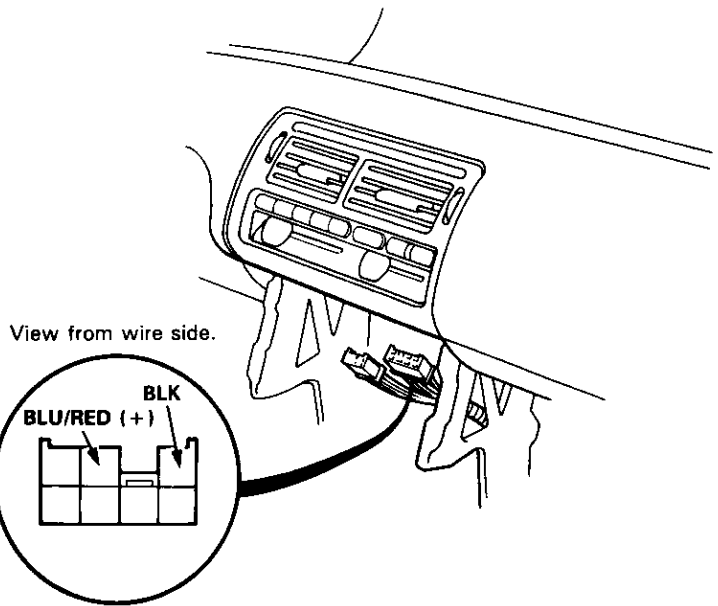

(cont'd)

Troubleshooting

Flowchart — Blower Motor (cont'd)

From page 21-10

UNDER-DASH FUSE/RELAY BOX

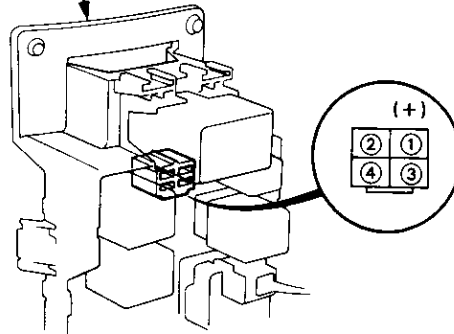

Turn the ignition switch ON.

Measure voltage between the No. ① terminal (+) and body ground (-).

Is there battery voltage?

NO

Replace the under-dash fuse/relay box.

YES

Turn the ignition switch OFF.

Check for continuity between the No. ③ terminal and body ground.

Is there continuity?

NO

Check for an open in the BLK wire between the No. ③ terminal and body ground. If the wire is OK, check for poor ground at G402.

YES

Repair open in the BLU/WHT wire between the blower motor relay and blower motor.



Flowchart — Mode Control Motor

Mode control motor does not run, or one or more modes are inoperative.

Check No. 9 (15 A) fuse in the under-dash fuse/relay box.

Is the fuse OK?

NO

Replace the fuse.

YES

Turn the ignition switch ON.

Switch back and forth from FRESH to REC.

Does the recirculation control motor run?

NO

Turn the ignition switch OFF, then disconnect the mode control motor 8P connector.

Turn the ignition switch ON.

Measure voltage between the BLK/YEL wire terminal(+) and body ground(-).

Is there battery voltage?

NO

Repair open in the BLK/YEL wire between the under-dash fuse/relay box and mode control motor.

YES

Turn the ignition switch OFF.

Remove the stereo radio/cassette player (see section 23).

Disconnect the heater control panel 16P connector.

Check for continuity in the BLK wire between the heater control panel and body ground.

Is there continuity?

NO

Check for an open in the BLK wire between the heater control panel and body ground. If the wire is OK, check for poor ground at G401.

YES

Replace the heater control panel.

Disconnect the mode control motor 8P connector.

Turn the ignition switch ON.

Measure voltage between the BLK/YEL wire terminal (+) and body ground (-).

Is there battery voltage?

NO

Repair open in the BLK/YEL wire between the under-dash fuse/relay box and mode control motor.

YES

Turn the ignition switch OFF.

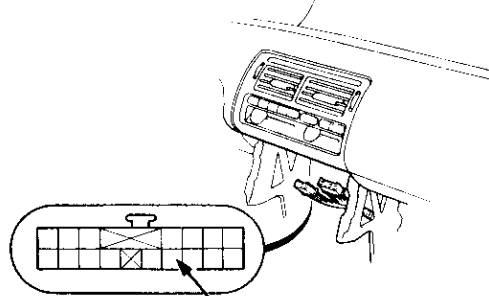

No. 13 BLK

View from wire side.

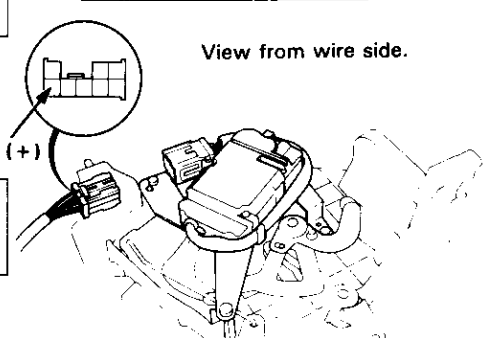

BLK/YEL (+)

View from wire side.

To page 21-14

(cont'd)

Troubleshooting

Flowchart — Mode Control Motor (cont'd)

From page 21-13

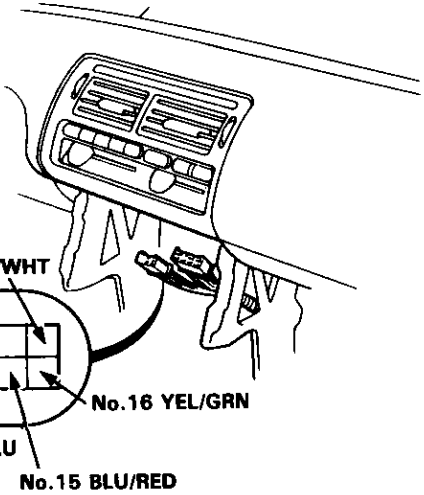
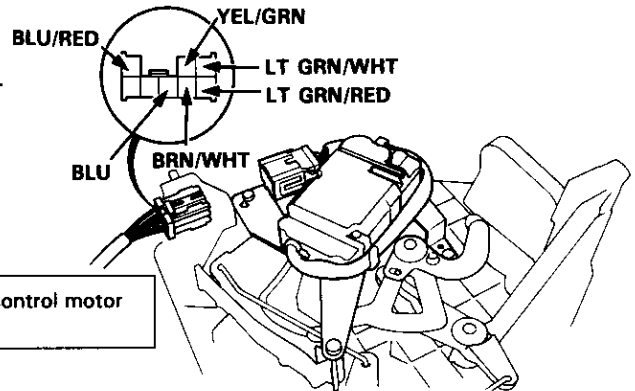
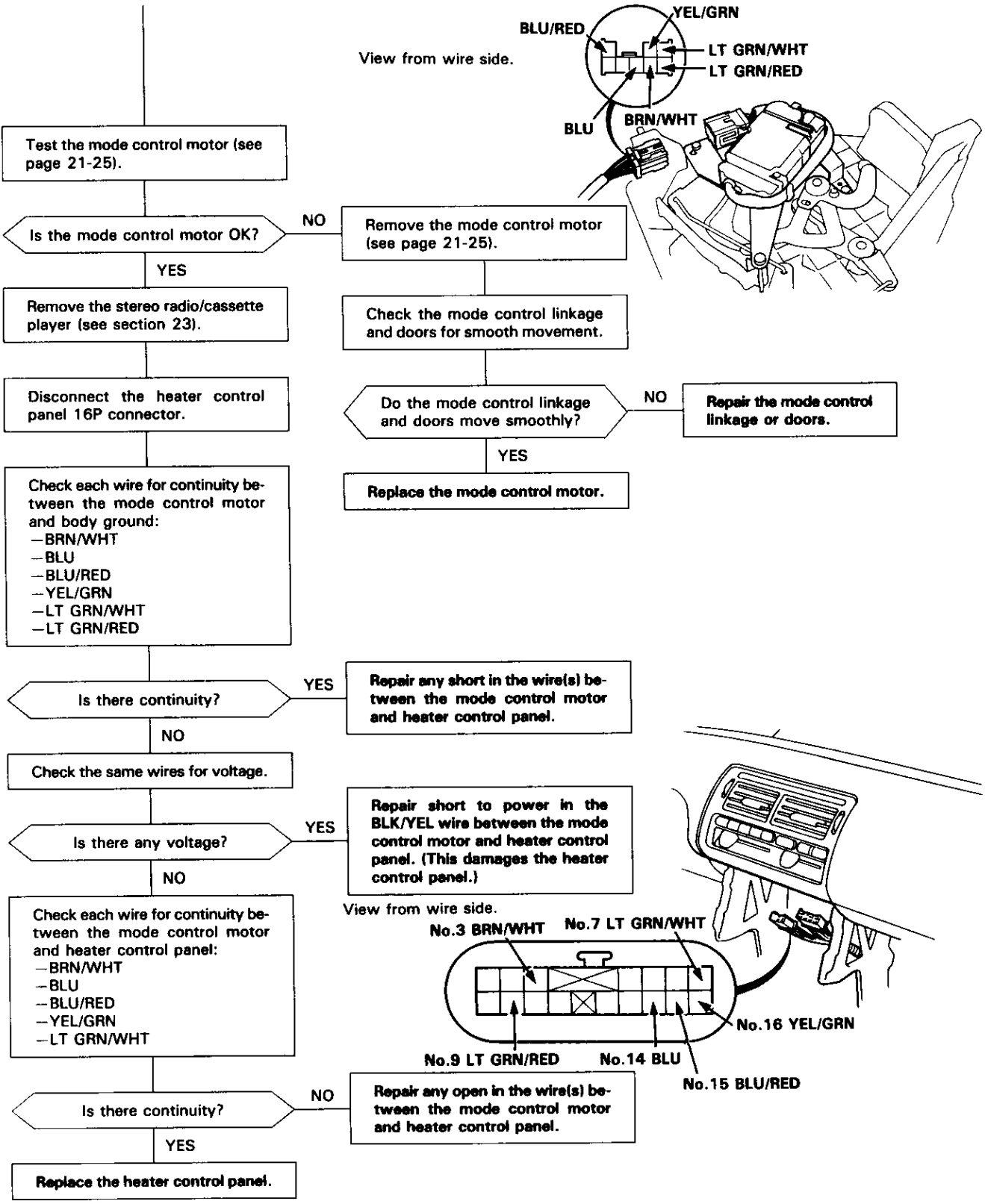



Flowchart — Recirculation Control Motor

Recirculation control doors do not change between FRESH and REC.

Check No. 9 (15 A) fuse in the under-dash fuse/relay box.

Is the fuse OK?

NO

Replace the fuse.

YES

Turn the ignition switch ON.

Switch between the different ventilation modes (VENT, HEAT, etc.).

Does the mode control motor run?

NO

Turn the ignition switch OFF, then disconnect the recirculation control motor 4P connector.

Turn the ignition switch ON.

Measure voltage between the BLK/YEL wire terminal(+) and body ground(-).

Is there battery voltage?

NO

Repair open in the BLK/YEL wire between the under-dash fuse/relay box and recirculation control motor.

YES

Turn the ignition switch OFF.

Remove the stereo radio/cassette player (see section 23).

Disconnect the heater control panel 16P connector.

Check for continuity in the BLK wire between the heater control panel and body ground.

Is there continuity?

NO

Check for an open in the BLK wire between the heater control panel and body ground. If the wire is OK, check for poor ground at G401.

YES

Replace the heater control panel.

Turn the ignition switch OFF.

Disconnect the recirculation control motor 4P connector.

Turn the ignition switch ON.

Measure voltage between the BLK/YEL wire terminal (+) and body ground (-).

Is there battery voltage?

NO

Repair open in the BLK/YEL wire between the under-dash fuse/relay box and recirculation control motor.

YES

Turn the ignition switch OFF.

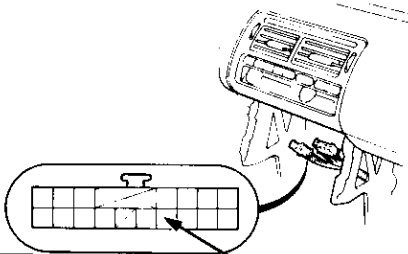

No. 13 BLK

View from wire side.

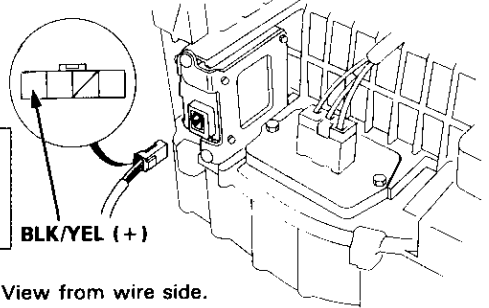

BLK/YEL (+)

View from wire side.

To page 21-16

(cont'd)

Troubleshooting

Flowchart — Recirculation Control Motor (cont'd)

From page 21-15

Test the recirculation control motor (see page 21-26).

Is the recirculation control motor OK?

NO

Remove the recirculation control motor (see page 21-26).

YES

Check the recirculation control linkage and doors for smooth movement.

Remove the stereo radio/cassette player (see section 23).

Do the recirculation control linkage and doors move smoothly?

NO

Repair the recirculation control linkage or doors.

Disconnect the heater control panel 16P connector.

YES

Replace the recirculation control motor.

Check for continuity in the GRN/WHT and GRN/RED wires between the recirculation control motor and body ground.

View from wire side.

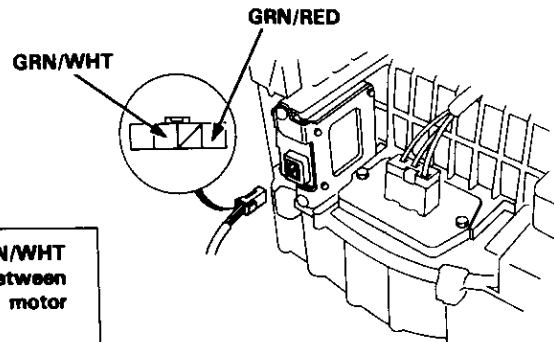

Is there continuity?

YES

Repair short in the GRN/WHT and/or GRN/RED wire(s) between the recirculation control motor and heater control panel.

NO

Check the same wires for voltage.

Is there any voltage?

YES

Repair short to power in the BLK/YEL wire between the recirculation control motor and heater control panel. (This damages the heater control panel.)

NO

Check for continuity in the GRN/WHT and GRN/RED wires between the recirculation control motor and heater control panel.

Is there continuity?

NO

Repair open in the GRN/WHT and/or GRN/RED wire(s) between the recirculation control motor and heater control panel.

YES

Replace the heater control panel.

View from wire side.

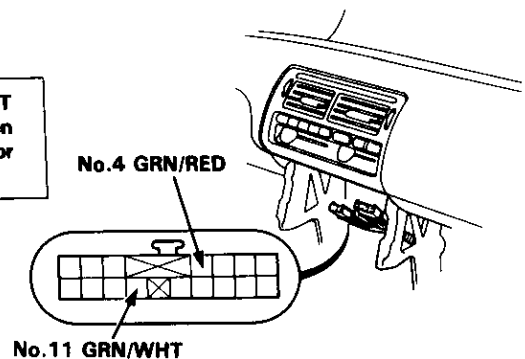

Blower Unit

Replacement

CAUTION:

- All SRS electrical wiring harnesses are covered with yellow outer insulation.
- Before disconnecting the SRS wire harness, install the short connector(s) on the airbag(s) (see page 23-294).
- Replace the entire affected SRS harness assembly if it has an open circuit or damaged wiring.

NOTE: The radio may have a coded theft protection circuit. Be sure to get the customer's code number before:

- Disconnecting the battery.
- Removing the No. 43 (10 A) fuse in the under-hood fuse/relay box.
- Removing the radio.

After service, reconnect power to the radio and turn it on. When the word "CODE" is displayed, enter the customer's 5-digit code to restore radio operation.

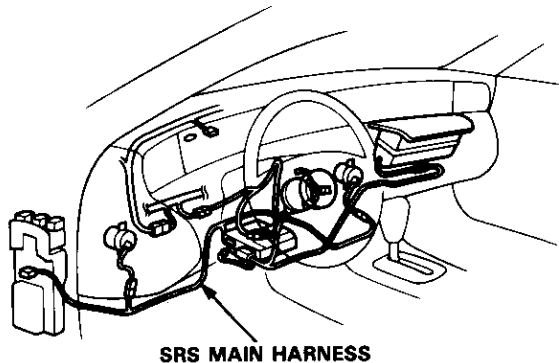

NOTE: The blower motor, recirculation control motor, and blower resistor can be replaced without removing the blower unit (see page 21-18).

1. Remove the glove box and glove box frame (see section 20).

WITHOUT AIR CONDITIONING

- 2-a. Remove the four self-tapping screws and the heater duct.

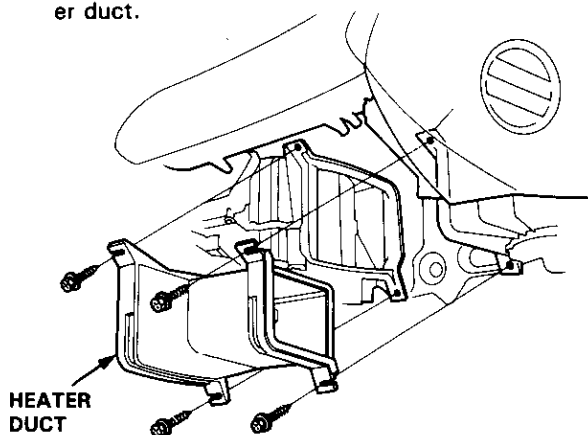

WITH AIR CONDITIONING

- 2-b. Remove the evaporator (see page 22-29).

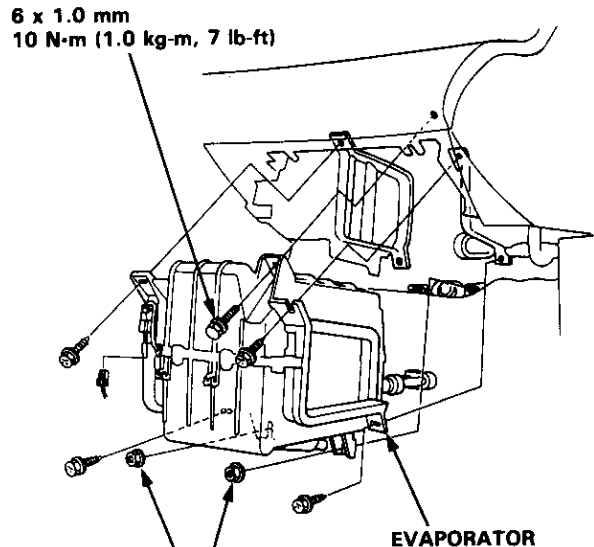

6 x 1.0 mm
10 N·m (1.0 kg-m, 7 lb-ft)

3. Disconnect the connectors from the blower motor, blower resistor, and recirculation control motor.
4. Remove the two bolts, nut and blower unit.

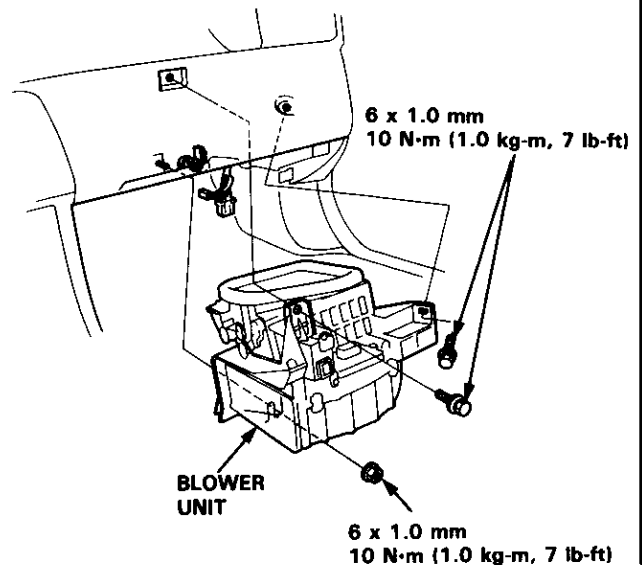

5. Install in the reverse order of removal, and make sure there are no air leaks.

Blower Unit

Overhaul

NOTE:

- Before reassembly, make sure that the air doors and linkage move smoothly without binding.
- When reattaching the recirculation control motor, make sure its positioning will not allow the air doors to be pulled too far. Attach the recirculation control motor and all linkage, then apply battery voltage and watch the movement of the doors. If necessary, loosen the holding screw and move the recirculation control motor up or down.

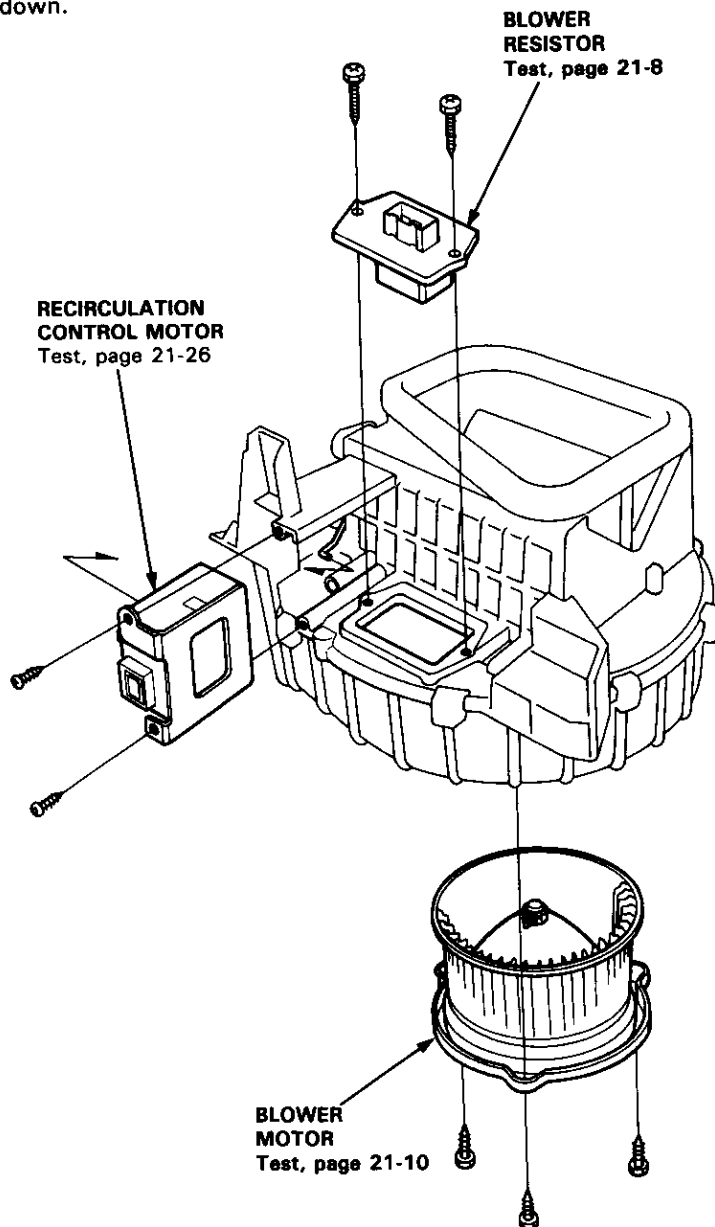

Heater Unit Replacement



CAUTION:

- All SRS electrical wiring harnesses are covered with yellow outer insulation.
- Before disconnecting the SRS wire harness, install the short connector(s) on the airbag(s) (see page 23-294).
- Replace the entire affected SRS harness assembly if it has an open circuit or damaged wiring.

NOTE: The radio may have a coded theft protection circuit. Be sure to get the customer's code number before:

- Disconnecting the battery.
- Removing the No. 43 (10 A) fuse in the under-hood fuse/relay box.
- Removing the radio.

After service, reconnect power to the radio and turn it on. When the word "CODE" is displayed, enter the customer's 5-digit code to restore radio operation.

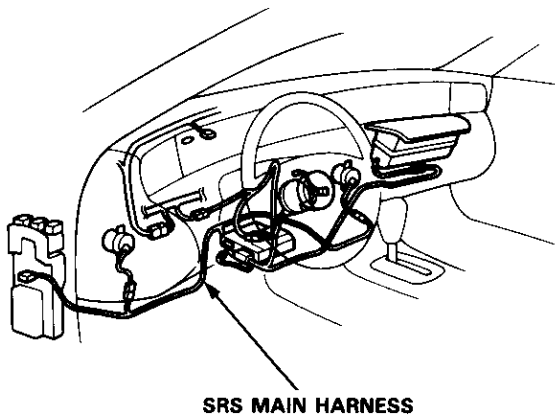

1. When the engine is cool, drain engine coolant from the radiator (see section 10).

⚠ WARNING

- Do not remove the radiator cap when the engine is hot; the engine coolant is under pressure and could severely scald you.
- Keep hands away from the radiator fan. The fan may start automatically without warning and run for up to 15 minutes even after the engine is turned off.

2. Snap open the cable clamp and disconnect the heater valve cable from the heater valve.

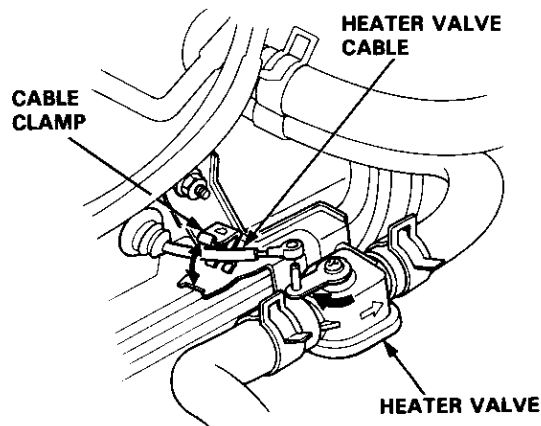

3. Disconnect the heater hoses at the heater.

CAUTION: Engine coolant will damage paint. Quickly rinse any spilled engine coolant from painted surfaces.

NOTE: Engine coolant will run out when the hoses are disconnected, drain it into a clean drip pan.

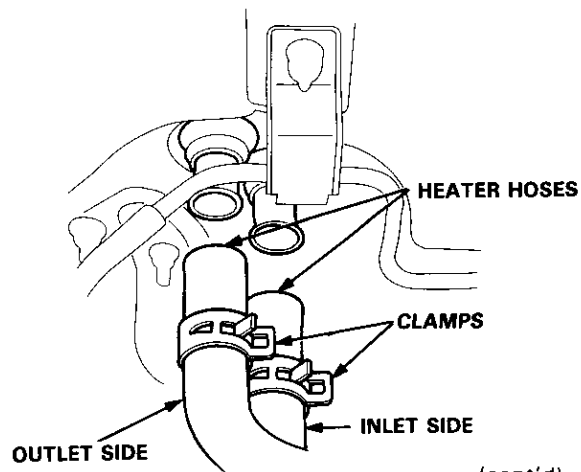

(cont'd)

Heater Unit

Replacement (cont'd)

4. Remove the two heater unit mounting nuts from the engine compartment side.

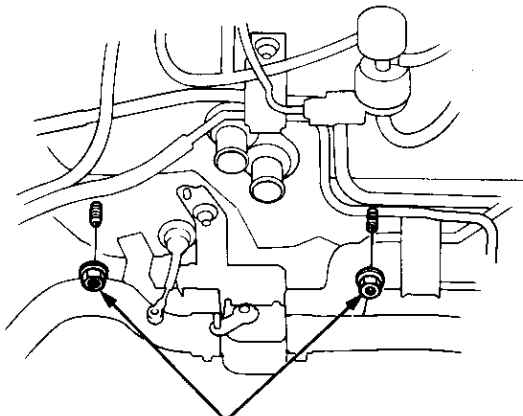

8 x 1.25 mm
22 N·m (2.2 kg-m, 16 lb-ft)

5. Remove the dashboard (see section 20).
6. Remove the heater duct (see page 21-17) or evaporator (see page 22-29).
7. Remove the two mounting bolts and heater unit.

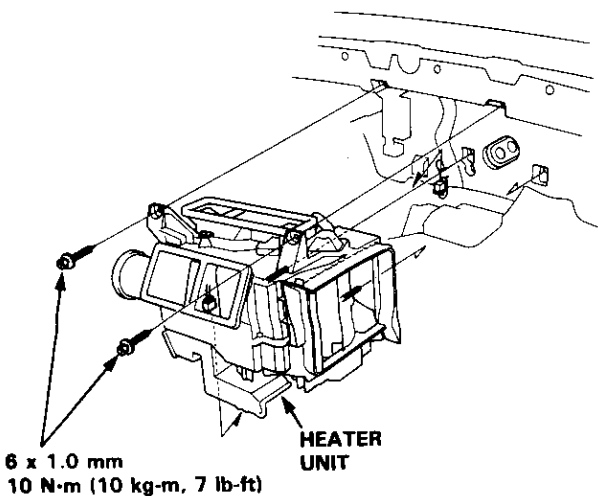

6 x 1.0 mm
10 N·m (10 kg-m, 7 lb-ft)

HEATER
UNIT

8. Install in the reverse order of removal, and:

- Do not interchange the inlet and outlet hoses.
- Loosen the bleed bolt on the engine and refill the radiator and reservoir tank with the proper engine coolant mixture (see section 10). Tighten the bleed bolt when all the trapped air has escaped and engine coolant begins to flow from it (see section 10).
- Connect all cables and make sure they are properly adjusted (see page 21-24).



Overhaul

1. Remove the heater unit (see page 21-19).
2. Remove the three screws and defroster duct.
3. Remove the screw and pipe clamp.
4. Remove the screw and core clamp.
5. Pull the heater core from the heater unit.

NOTE: Be careful not to bend the inlet and outlet pipes during heater core removal.

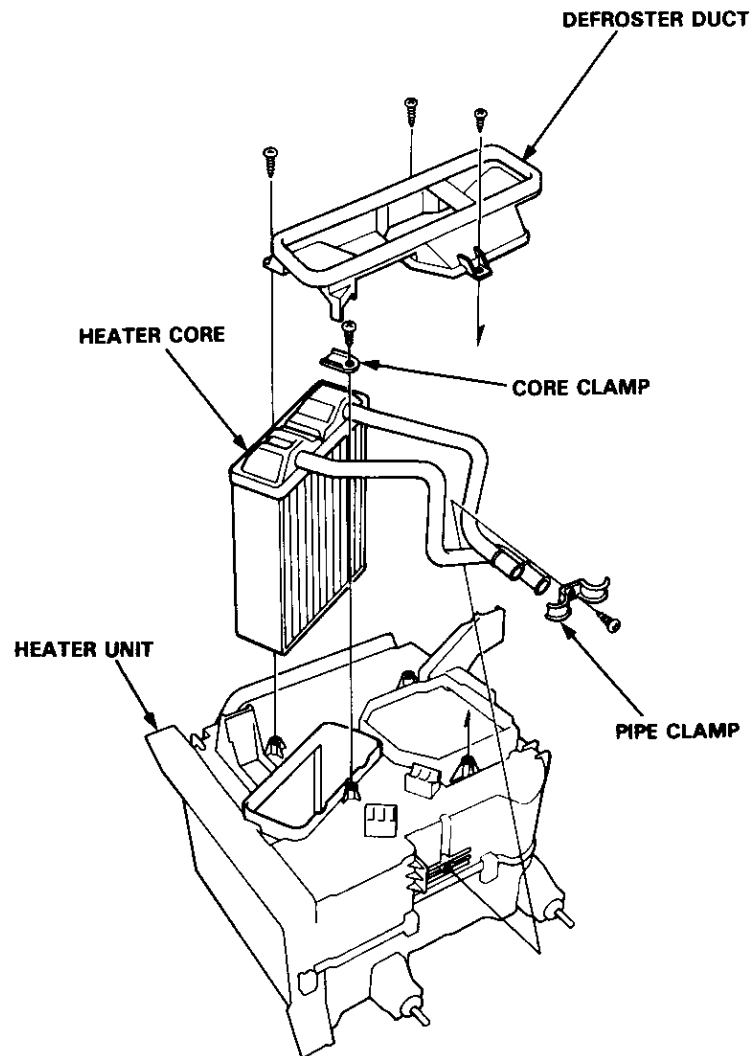

Install in the reverse order of removal, and:

Loosen the bleed bolt on the engine, and refill the radiator and reservoir tank with the proper engine coolant mixture. Tighten the bleed bolt when all the trapped air has escaped and engine coolant begins to flow from it.

Heater Unit

Heater Linkage Adjustment

DEF Door Adjustment

Set the mode control switch on HEAT for adjusting DEF leak (shut ~ 20%).

1. Loosen the adjusting screw.
2. Adjust the adjusting link.
3. Tighten the adjusting screw.

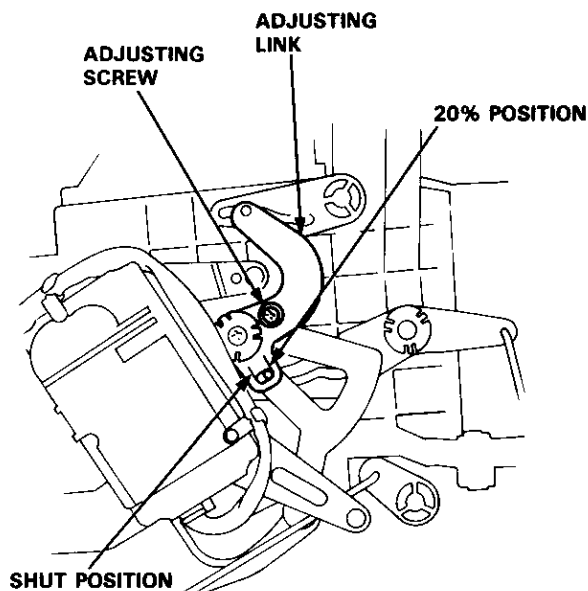

Heater Control Panel

Replacement

1. Remove the front console (see section 20).
2. Remove the stereo radio/cassette player (see section 23).
3. Disconnect the air mix control cable from the heater unit (see page 21-24).
4. Remove the three self-tapping screws. Disconnect the connectors and remove the heater control panel/center air vent assembly.

NOTE: The locking tabs are on the bottom of the connectors.

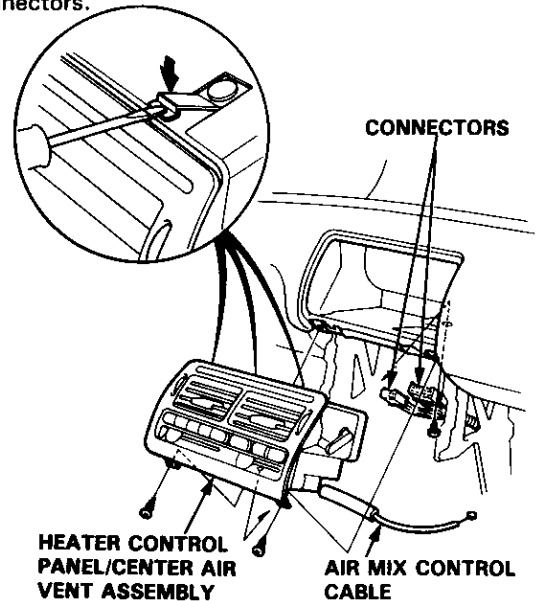

5. Remove the two self-tapping screws, and remove the heater control panel from the center air vent.

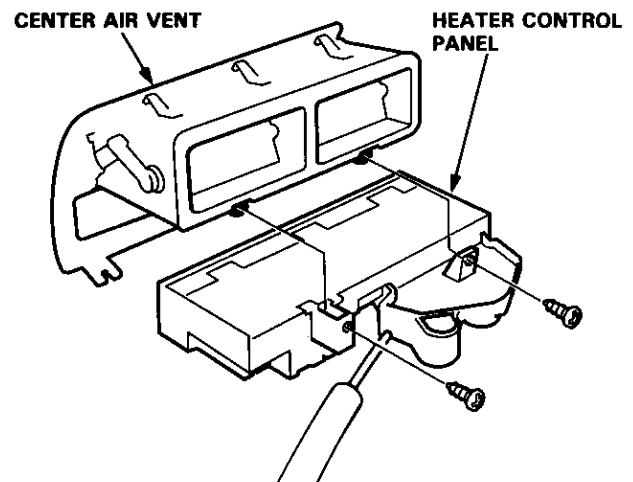

6. Install in the reverse order of removal, and refer to page 21-24 for air mix control cable installation. If necessary, adjust the heater valve cable.



Overhaul

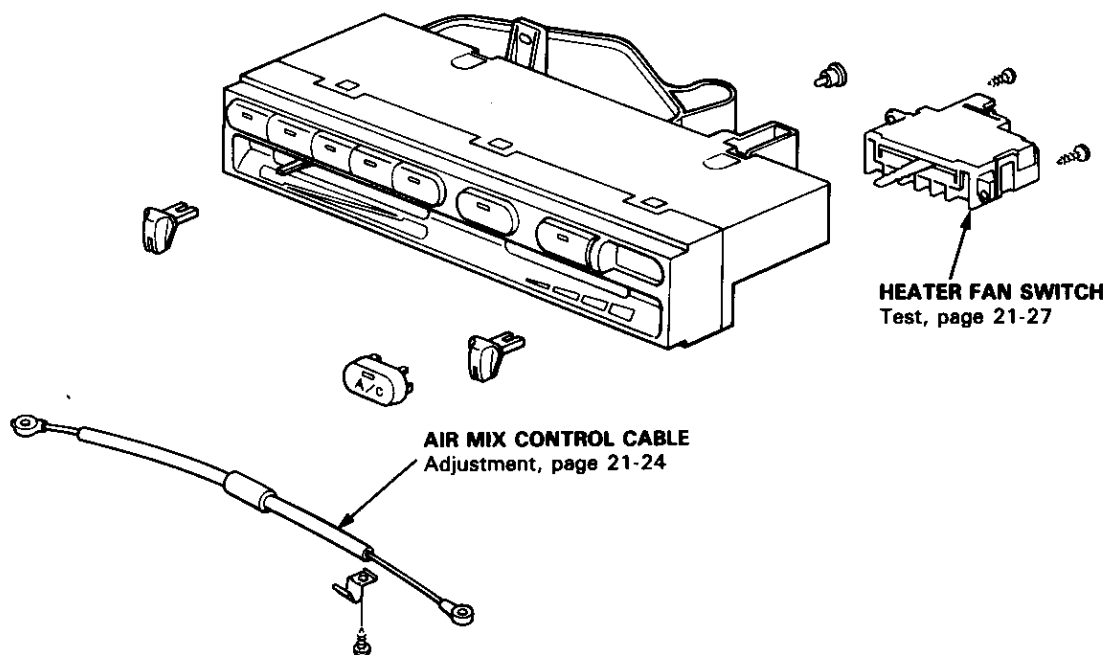

Air Mix Control Cable Replacement

1. Remove the screw and slide plate.
2. Remove the self-tapping screw and cable clamp.
3. Lift the end of the temperature control lever up and remove the air mix control cable.

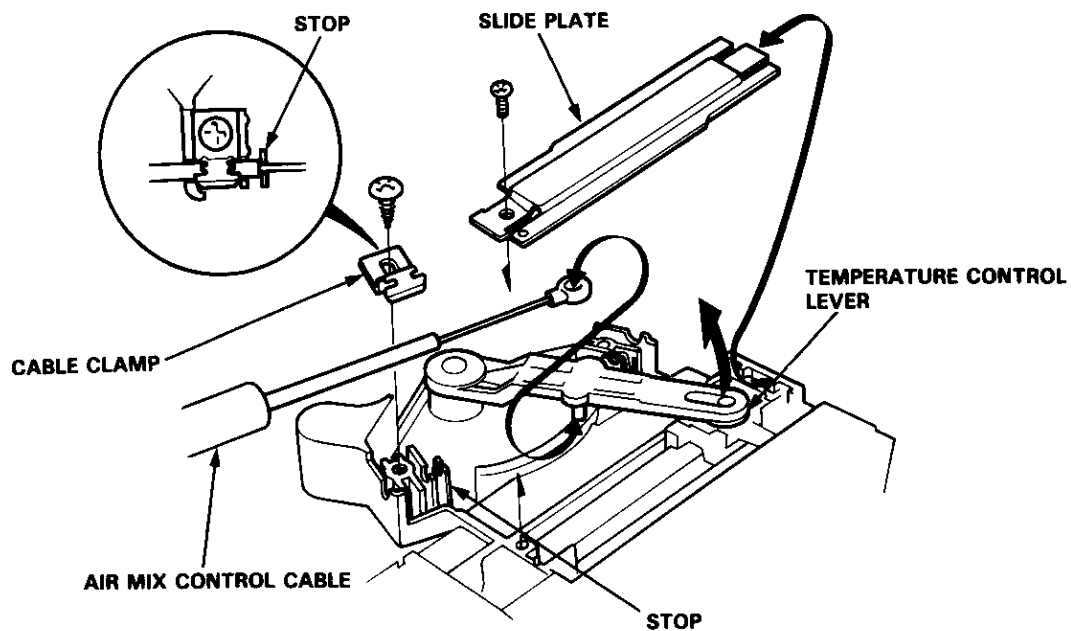

4. Install in the reverse order of removal, and:
 - Be sure the end of the cable housing is against the stop before tightening the cable clamp.
 - After assembly, check that the temperature control lever slides smoothly through the full stroke from right to left.

Heater Control Cables

Heater Valve Cable Adjustment

1. Disconnect the heater valve cable from the heater valve.
2. Set the temperature control lever on COOL.
3. Connect the end of the heater valve cable to the cable arm.
4. Gently slide the heater valve cable outer housing back from the end enough to take up any slack in the heater valve cable, but not enough to make the temperature control lever move. Hold the end of the heater valve cable housing against the stop, then snap the heater valve cable housing into the cable clamp.

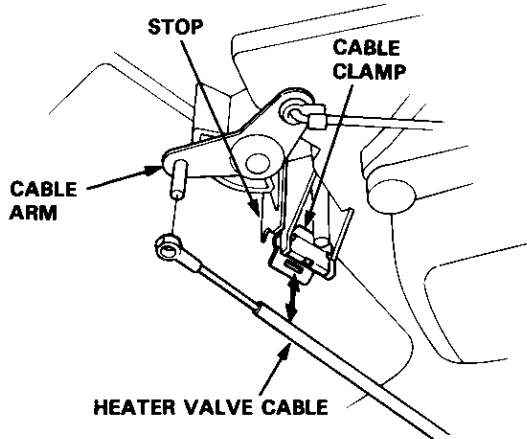

5. Turn the heater valve arm to shut and connect the end of the heater valve cable to the heater valve arm.
6. Gently slide the heater valve cable outer housing back from the end enough to take up any slack in the heater valve cable, but not enough to make the temperature control lever move, then snap the heater valve cable housing into the cable clamp.

NOTE: The air mix control cable should always be adjusted when ever the heater valve cable has been disconnected.

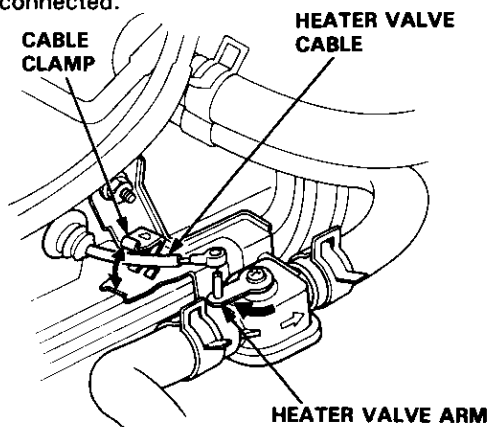

Air Mix Control Cable Adjustment

1. Set the temperature control lever on COOL.
2. Connect the end of the air mix control cable to the cable arm.
3. Gently slide the air mix control cable outer housing back from the end enough to take up any slack in the air mix control cable, but not enough to make the temperature control lever move, then snap the air mix control cable housing into the cable clamp.

NOTE: The heater valve cable should always be adjusted when ever the air mix control cable has been disconnected.

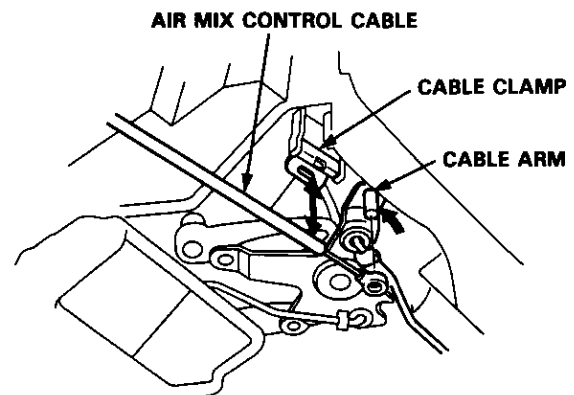

Mode Control Motor



Test

1. Connect battery power to the ⑧ terminal of the mode control motor and connect ground to the ④ terminal.
2. Using a jumper wire, short the ④ terminal individually to the ①, ②, ③, ⑤ and ⑥ terminals, in that order.
 - Each time the short circuit is made, the mode control motor should run smoothly and stop.

NOTE: If the mode control motor does not run when shorting the first terminal, short that terminal again after shorting the other terminals. The mode control motor is normal if it runs when shorting the first terminal again.

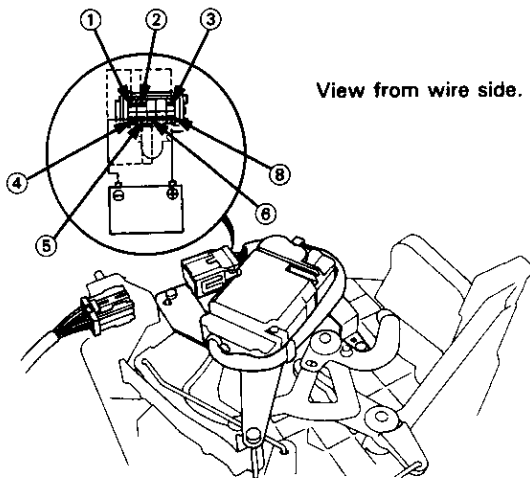

3. If the mode control motor does not run in step 2, remove it, and check the mode control linkage and doors for smooth movement. If the mode control linkage and doors move smoothly, replace the mode control motor.

Replacement

1. Disconnect the mode control motor 8P connector.
2. Remove the three screws, mode control motor, and flange collar.

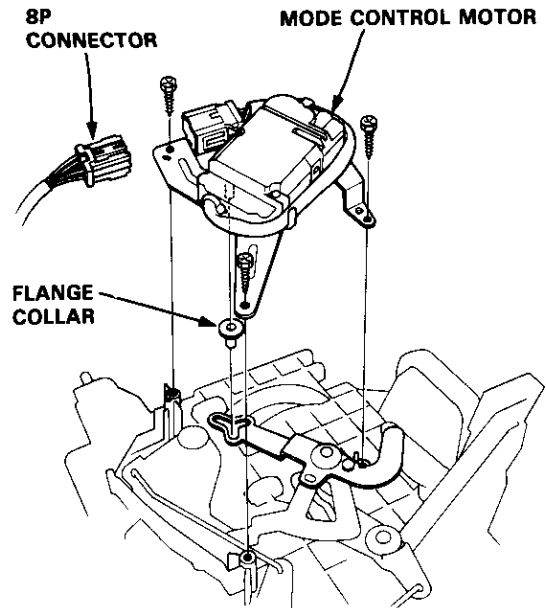

3. Install in the reverse order of removal. After installation, make sure the mode control motor operates smoothly.

Recirculation Control Motor

Test

1. Connect battery power to the ① terminal of the recirculation control motor and connect ground to the ② and ③ terminals; the recirculation control motor should run smoothly.
2. Disconnect ground from ② or ③; the recirculation control motor should stop at FRESH or REC.

CAUTION: Never connect the battery in the opposite direction.

NOTE: Don't cycle the recirculation control motor for a long time.

View from terminal side.

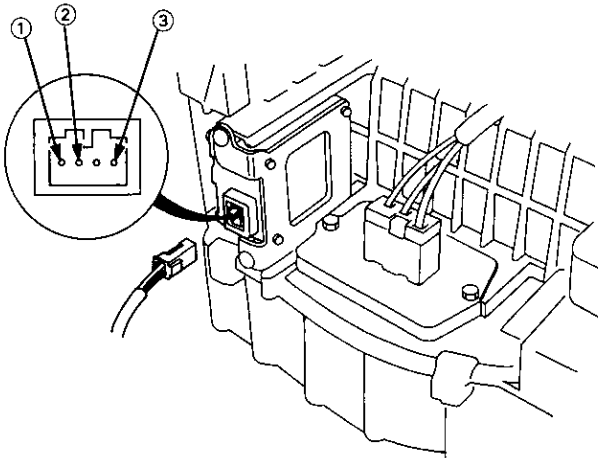

3. If the recirculation control motor does not run in step 1, remove it, and check the recirculation control linkage and doors for smooth movement. If the recirculation control linkage and doors move smoothly, replace the recirculation control motor.

Replacement

1. Disconnect the 4P connector from the recirculation control motor.
2. Remove the rod from the recirculation control motor.
3. Remove the two screws and recirculation control motor.

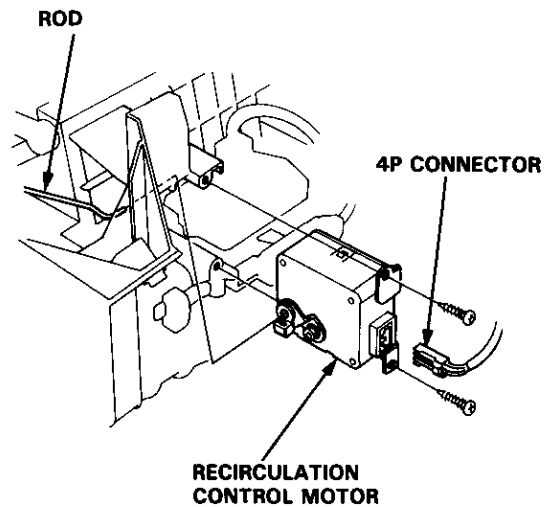

4. Install in the reverse order of removal. After installation, make sure the recirculation control motor operates smoothly.

Heater Fan Switch

Test

Check for continuity between the terminals according to the table below.

SWITCH CONNECTION

Terminal Position	1	2	3	4	5	6
OFF						
A	○	—	○	○		
B	○		○		○	
C	○	—	○	—	—	○
D	○	○	○			

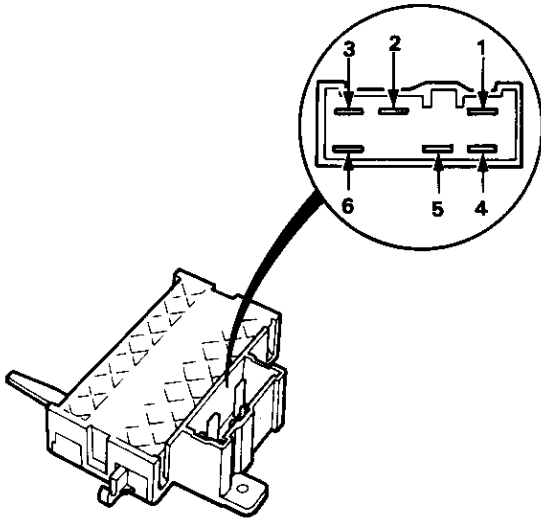

Relay

Test

There should be continuity between the C and D terminals.

There should be continuity between the A and B terminals when power and ground are connected to the C and D terminals.

There should be no continuity when power is disconnected.

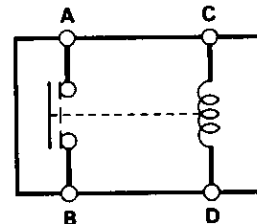
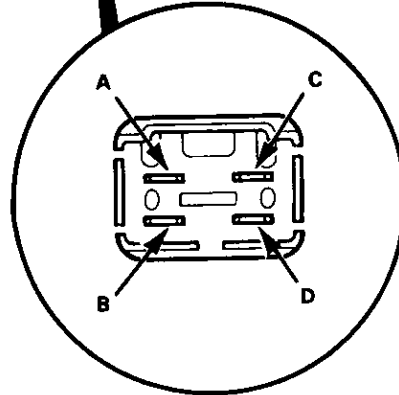
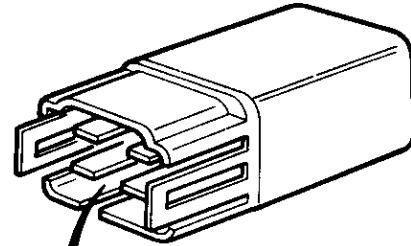

Mode Control Switch

Test

Check for continuity between the terminals according to the table below.

Terminal / Position	13	15	14	3	7	16
Heat	○—○					
Heat/Def	○—○		○			
Def	○—○			○		
Vent	○—○				○	
Heat/Vent	○—○					○

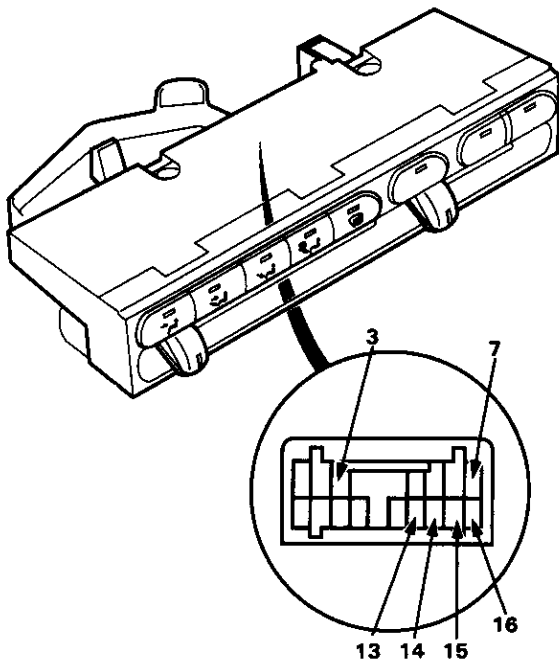

Recirculation Control Switch

Test

Check for continuity between the terminals according to the table below.

Terminal / Position	4	11	13
Fresh		○—○	○—○
Rec.	○—○		○—○

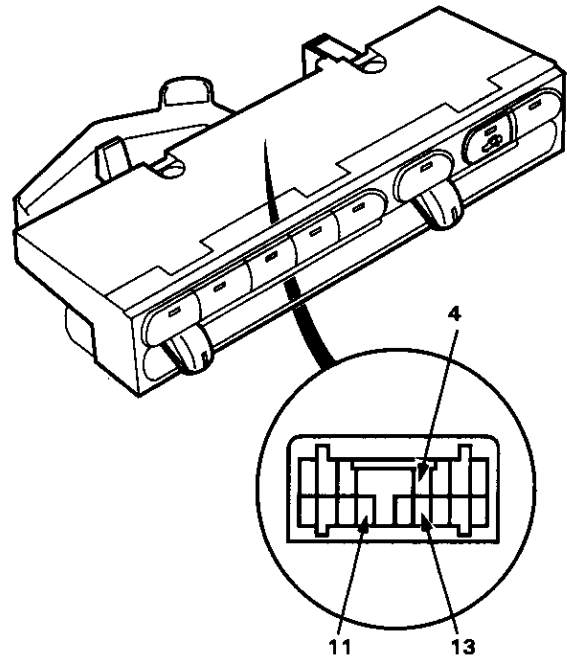

Air Conditioning

Special Tools	22-2	*Evaporator	
Illustrated Index	22-3	Replacement	22-29
Wiring/Connector Locations	22-4	Overhaul	22-31
Circuit Diagram	22-5	Compressor	
Description	22-6	Description	22-32
Troubleshooting		Illustrated Index	22-33
Reference Chart	22-7	Replacement	22-34
Flowchart		Clutch Inspection	22-36
Radiator Fan	22-8	Clutch Overhaul	22-37
Condenser Fan	22-10	Thermal Protector Replacement ...	22-39
Engine Coolant Temperature		Relief Valve Replacement	22-39
(ECT) Switch A	22-12	Belt Adjustment	22-40
Both Fans	22-13	Condenser	
Compressor	22-15	Replacement	22-41
A/C System	22-18	A/C System Service	
Radiator Fan Control Module Input		Evacuation	22-42
Tests	22-21	Charging	22-43
A/C Thermostat		Leak Test	22-44
Test	22-22		
Relay			
Test	22-22		
Diode			
Test	22-23		
A/C Switch			
Test	22-23		
A/C Service Tips and Precautions ...	22-24		
A/C System Service			
Recovery	22-25		
Performance Test	22-26		
Pressure Test Chart	22-28		

*: Read SRS precautions before working in this area.



Special Tools

Ref. No.	Tool Number	Description	Qty.	Page Reference
①	07JAC-SH20300	Shaft Ring Remover	1	22-38
②	07JGG-001010A	Belt Tension Gauge	1	22-40
③	07LAJ-PT3010A	Test Harness	1	22-17
④	07935-8050003	Flywheel Puller	1	22-37
⑤	07945-4150200	Seal Driver	1	22-37

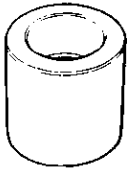

①

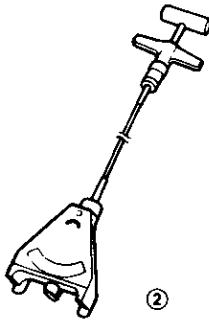

②

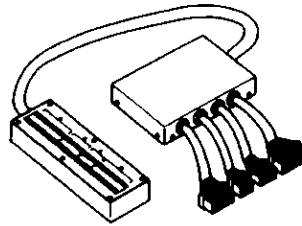

③

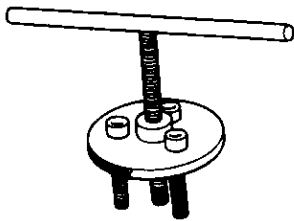

④

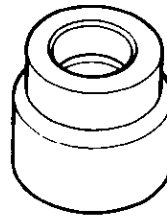

⑤

Illustrated Index



CAUTION:

- All SRS electrical wiring harnesses are covered with yellow outer insulation.
- Before disconnecting the SRS wire harness, install the short connector(s) on the airbag(s) (see page 23-294).
- Replace the entire affected SRS harness assembly if it has an open circuit or damaged wiring.

NOTE: The radio may have a coded theft protection circuit. Be sure to get the customer's code number before:

- Disconnecting the battery.
- Removing the No. 43 (10 A) fuse in the under-hood fuse/relay box.
- Removing the radio.

After service, reconnect power to the radio and turn it on. When the word "CODE" is displayed, enter the customer's 5-digit code to restore radio operation.

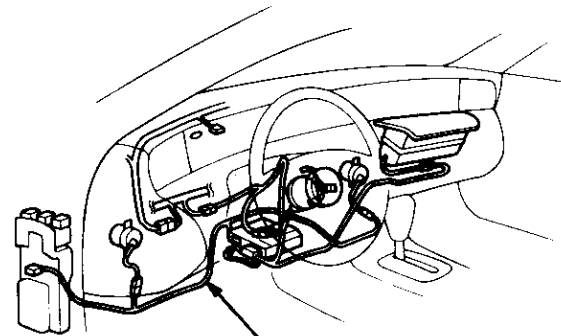

SRS MAIN HARNESS

EVAPORATOR
Replacement, page 22-29
Overhaul, page 22-31

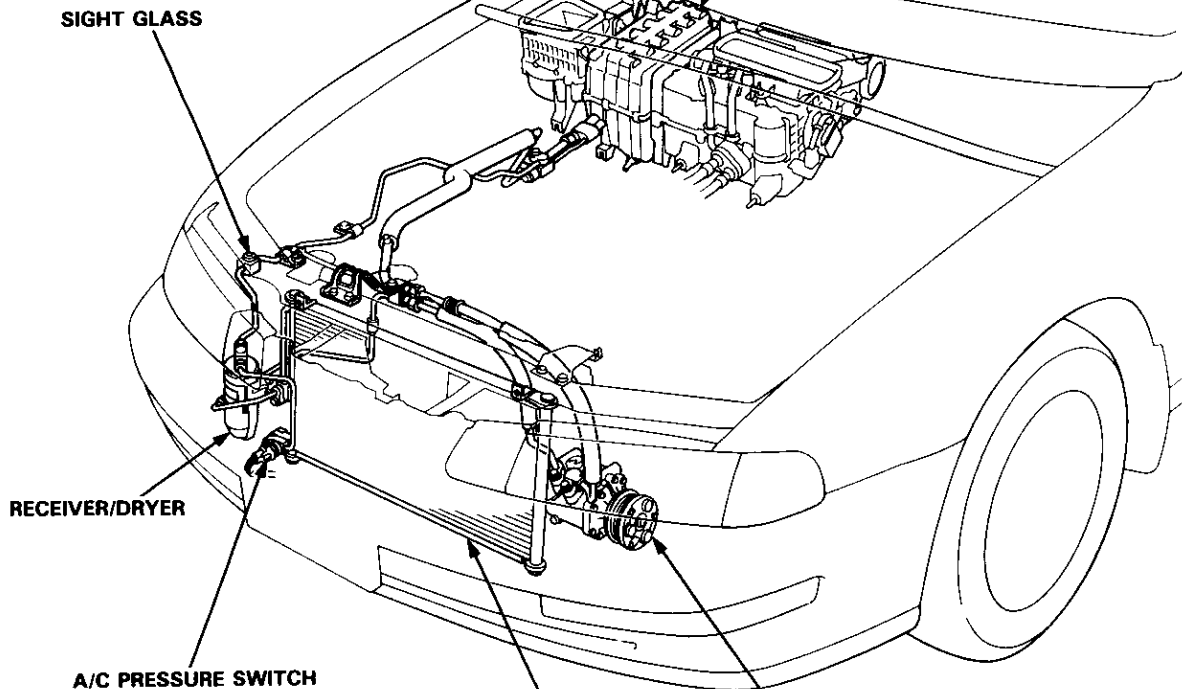

A/C PRESSURE SWITCH

When the refrigerant pressure is below 200 kPa (2.0 kg/cm², 28 psi) due to refrigerant leakage, or above 3200 kPa (32 kg/cm², 455 psi) due to coolant blockage, the A/C pressure switch opens the circuit to the A/C switch and stops the air conditioning to protect the compressor.

COMPRESSOR (SANDEN)
Replacement, page 22-34

CONDENSER
Replacement, page 22-41

Wiring/Connector Locations

CAUTION:

- All SRS electrical wiring harnesses are covered with yellow outer insulation.
- Before disconnecting the SRS wire harness, install the short connector(s) on the airbag(s) (see page 23-294).
- Replace the entire affected SRS harness assembly if it has an open circuit or damaged wiring.

NOTE: The radio may have a coded theft protection circuit. Be sure to get the customer's code number before:

- Disconnecting the battery.
- Removing the No. 43 (10 A) fuse in the under-hood fuse/relay box.
- Removing the radio.

After service, reconnect power to the radio and turn it on. When the word "CODE" is displayed, enter the customer's 5-digit code to restore radio operation.

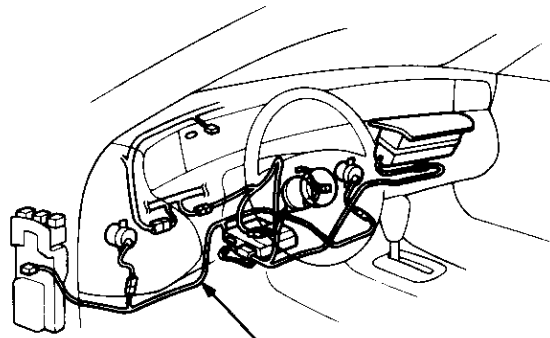

SRS MAIN HARNESS

RADIATOR FAN RELAY
(In the under-hood fuse/relay box)
Test, page 22-22

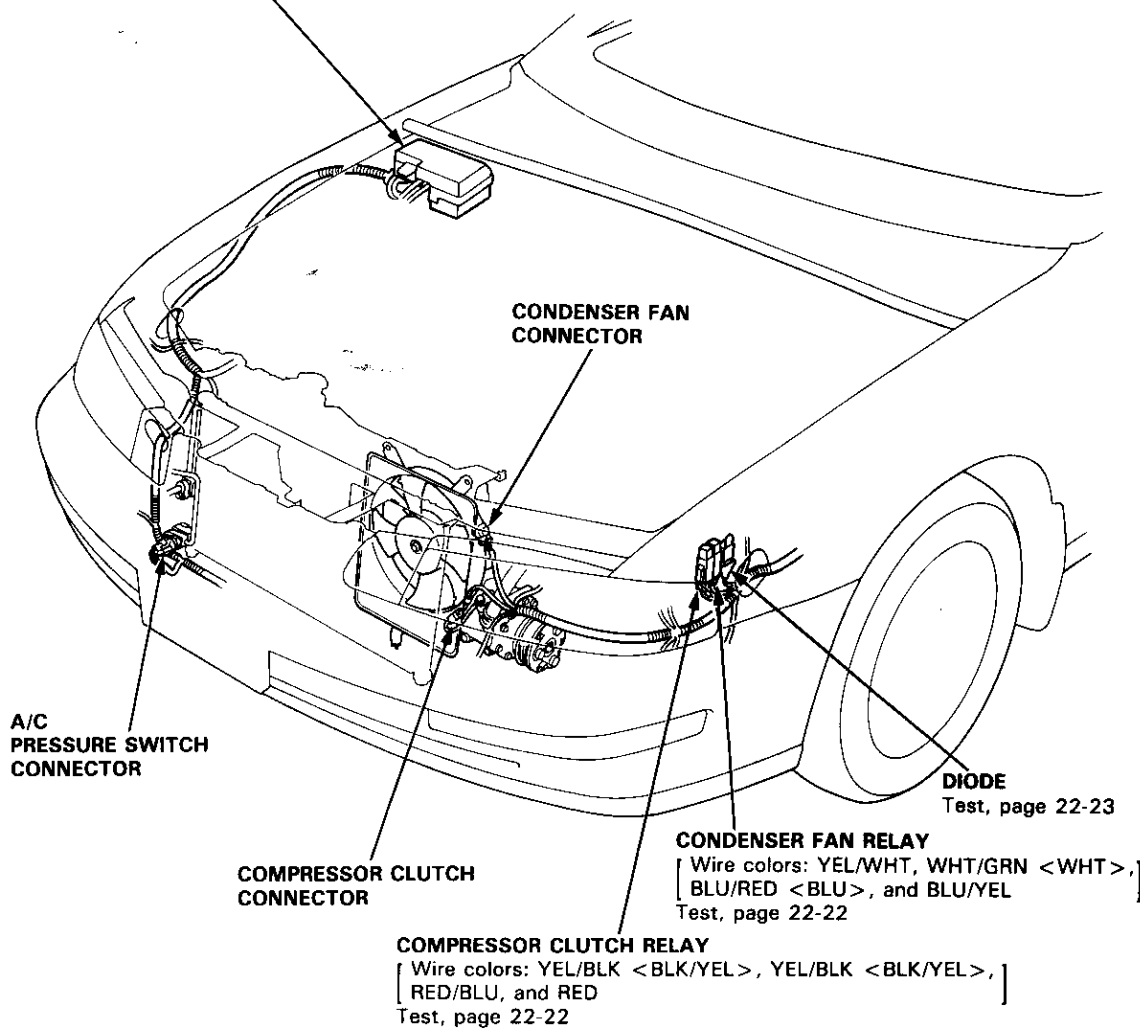

CONDENSER FAN CONNECTOR

A/C PRESSURE SWITCH CONNECTOR

COMPRESSOR CLUTCH CONNECTOR

DIODE
Test, page 22-23

CONDENSER FAN RELAY
[Wire colors: YEL/WHT, WHT/GRN <WHT>, BLU/RED <BLU>, and BLU/YEL
Test, page 22-22]

COMPRESSOR CLUTCH RELAY
[Wire colors: YEL/BLK <BLK/YEL>, YEL/BLK <BLK/YEL>, RED/BLU, and RED
Test, page 22-22]

< >: With optional A/C

Description

Outline

The air conditioning system delivers cooled air into the passenger compartment by circulating refrigerant through the system as shown below.

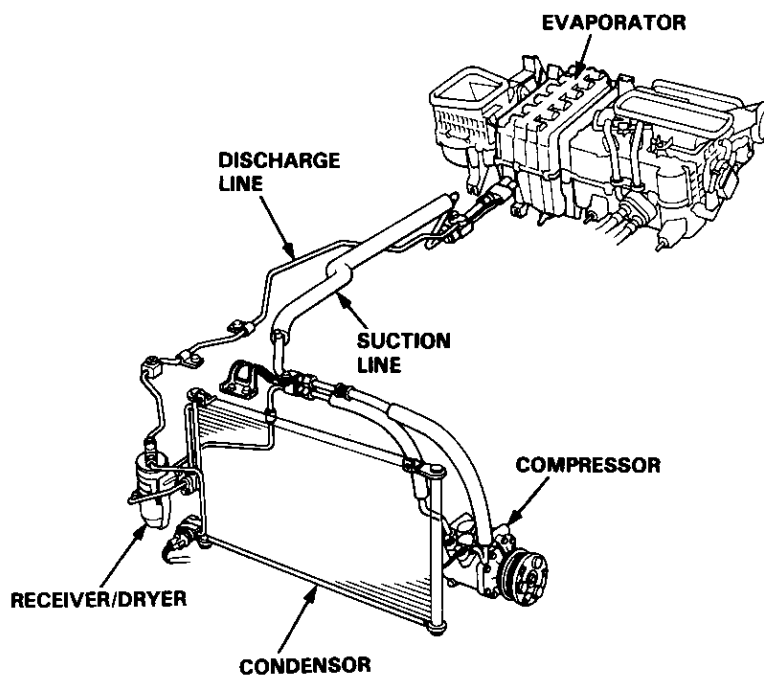
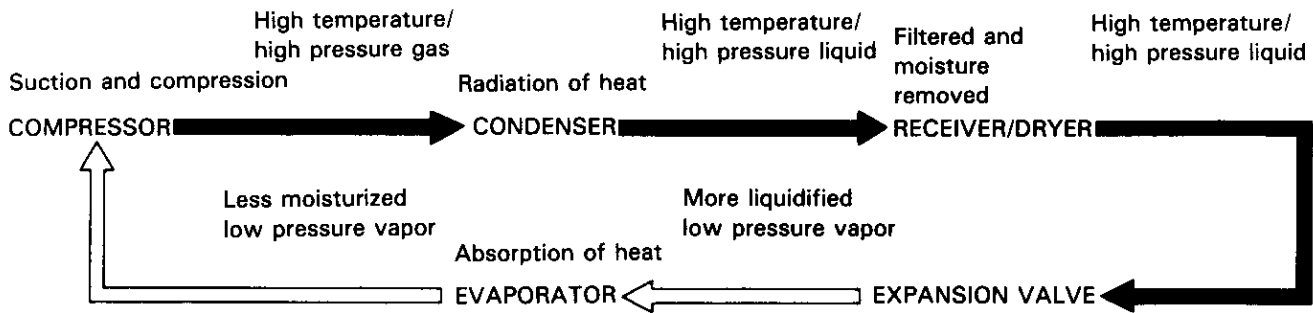

This car uses R-134a refrigerant which does not contain chlorofluorocarbons. Pay attention to the following service items:

- Do not mix refrigerants R-12 and R-134a. They are not compatible.
- Use only the recommended polyalkyleneglycol (PAG) refrigerant oil designed for the R-134a compressor. Intermixing the recommended (PAG) refrigerant oil with any other refrigerant oil will result in compressor failure.
- All A/C system parts (compressor, discharge line, suction line, evaporator, condenser, receiver/dryer, expansion valve, O-rings for joints) have to be designed for refrigerant R-134a. Do not confuse with R-12 parts.
- Use a halogen gas leak tester designed for refrigerant R-134a.
- R-12 and R-134a refrigerant servicing equipment are not interchangeable. Only use a Recovery/Recycling/Charging System that is U.L.-listed and is certified to meet the requirements of SAE J210 to service R-134a air conditioning systems.
- Always recover the refrigerant R-134a with an approved Recovery/Recycling/Charging System before disconnecting any A/C fitting.



Troubleshooting

Reference Chart

- Any abnormality must be corrected before continuing the test.
- Because of the precise measurements needed, use a multimeter when testing.

Before performing any troubleshooting procedures check:

- Fuses *1 No. 47 (15 A), *1 No. 45 (15 A), *2 No. 11 (10 A), *2 No. 9 (15 A)
- Grounds No. G401, G402, G301 <G381>, G201, G101
- Cleanliness and tightness of all connectors.

< >: With optional A/C

*1: In the under-hood fuse/relay box.

*2: In the under-dash fuse/relay box.

SYMPTOM	REMEDY
Radiator fan does not run at all.	Perform the procedures in the flowchart (see page 22-8).
Condenser fan does not run at all.	Perform the procedures in the flowchart (see page 22-10).
Both fans (radiator and condenser) do not run for engine cooling, but they both run with the A/C on.	Perform the procedures in the flowchart (see page 22-12).
Both fans do not run at all.	Perform the procedures in the flowchart (see page 22-13).
Compressor clutch does not engage.	Perform the procedures in the flowchart (see page 22-15).
A/C system does not come on (compressor and both fans).	Perform the procedures in the flowchart (see page 22-18).

Troubleshooting

Flowchart — Radiator Fan

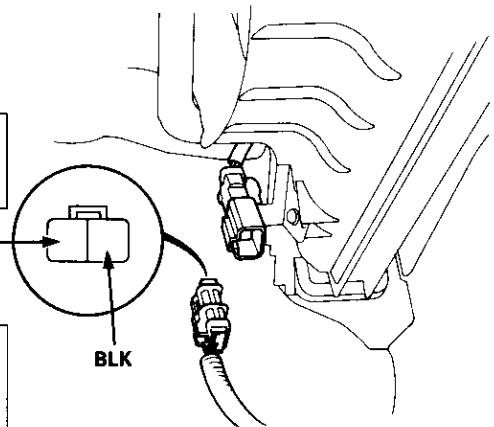
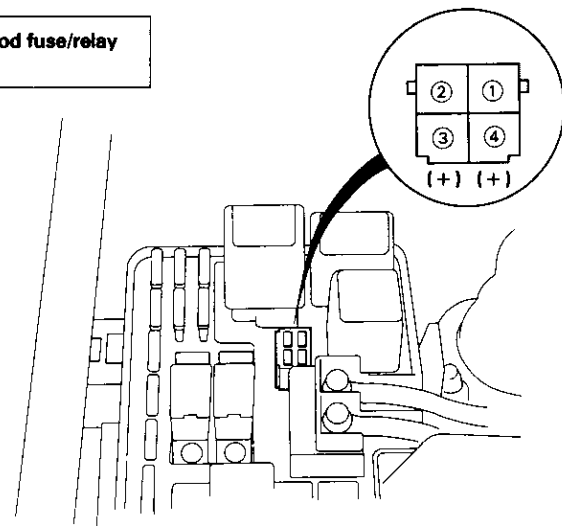
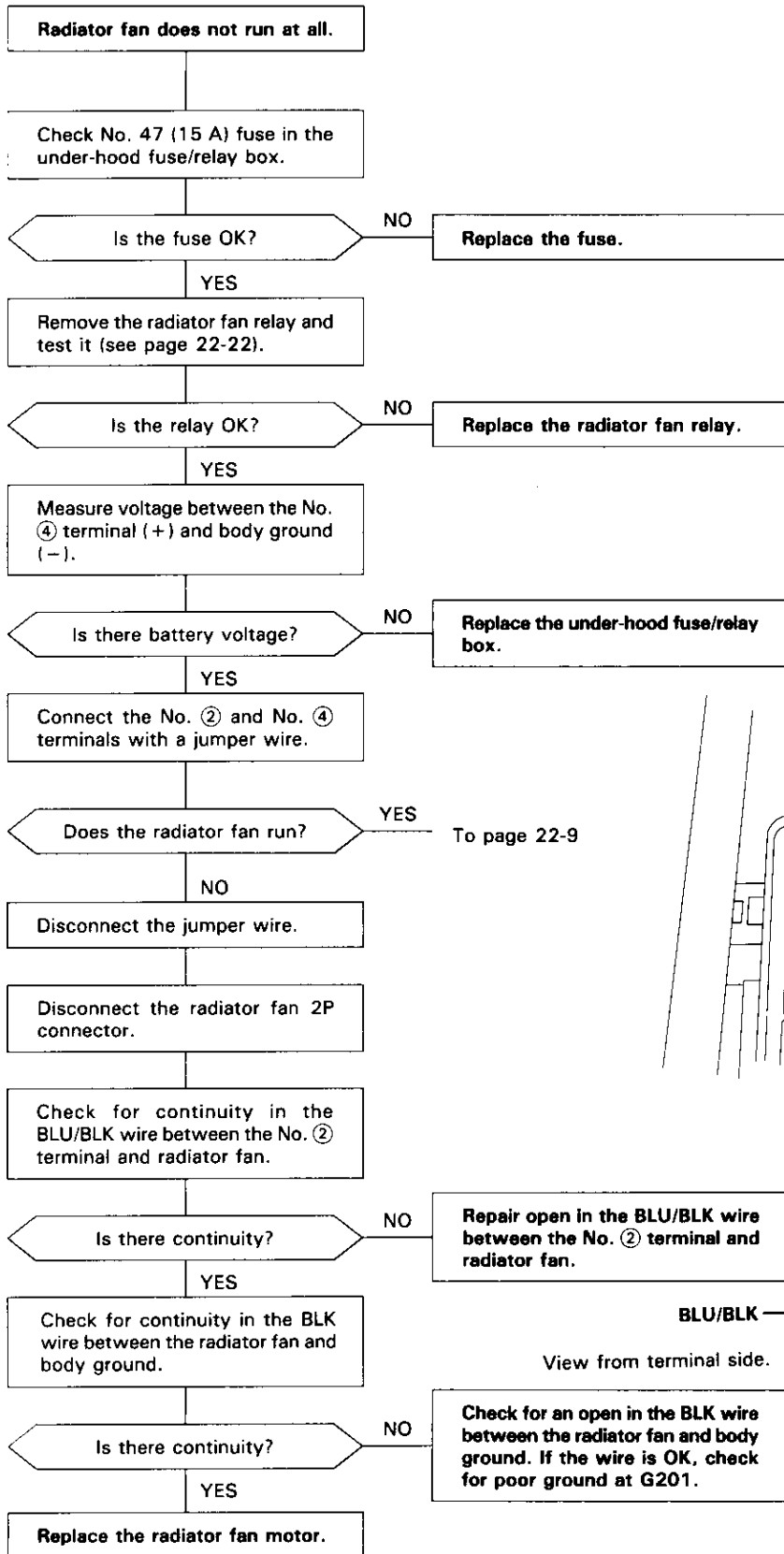



From page 22-8

Disconnect the jumper wire and turn the ignition switch ON.

Measure voltage between the No. ③ terminal (+) and body ground (-).

Is there battery voltage?

YES: Repair open in the BLU/RED wire between the No. ① terminal and diode.

NO

Measure voltage between the YEL wire terminal (+) of the radiator fan control module and body ground (-).

Is there battery voltage?

NO: Perform radiator fan control module input test (see page 22-21).

YES

Repair open in the YEL wire between the No. ③ terminal and radiator fan control module.

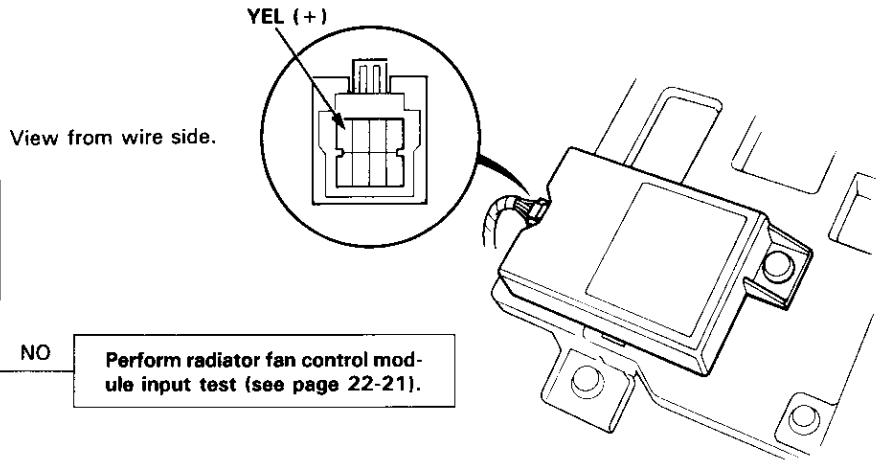

Troubleshooting

Flowchart — Condenser Fan

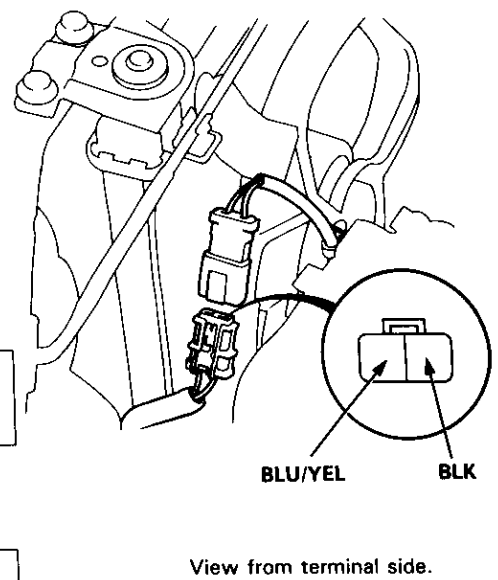
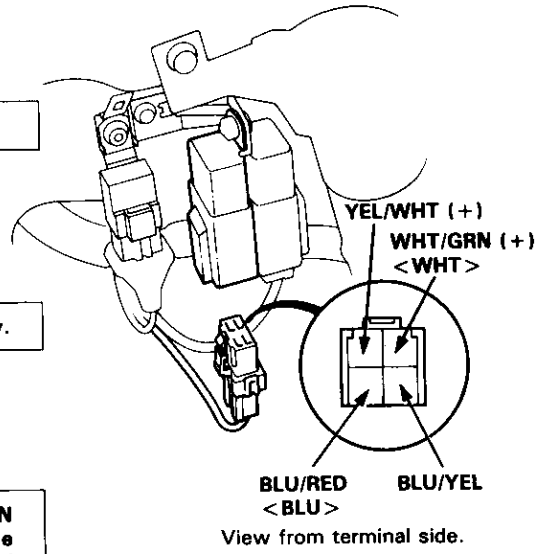
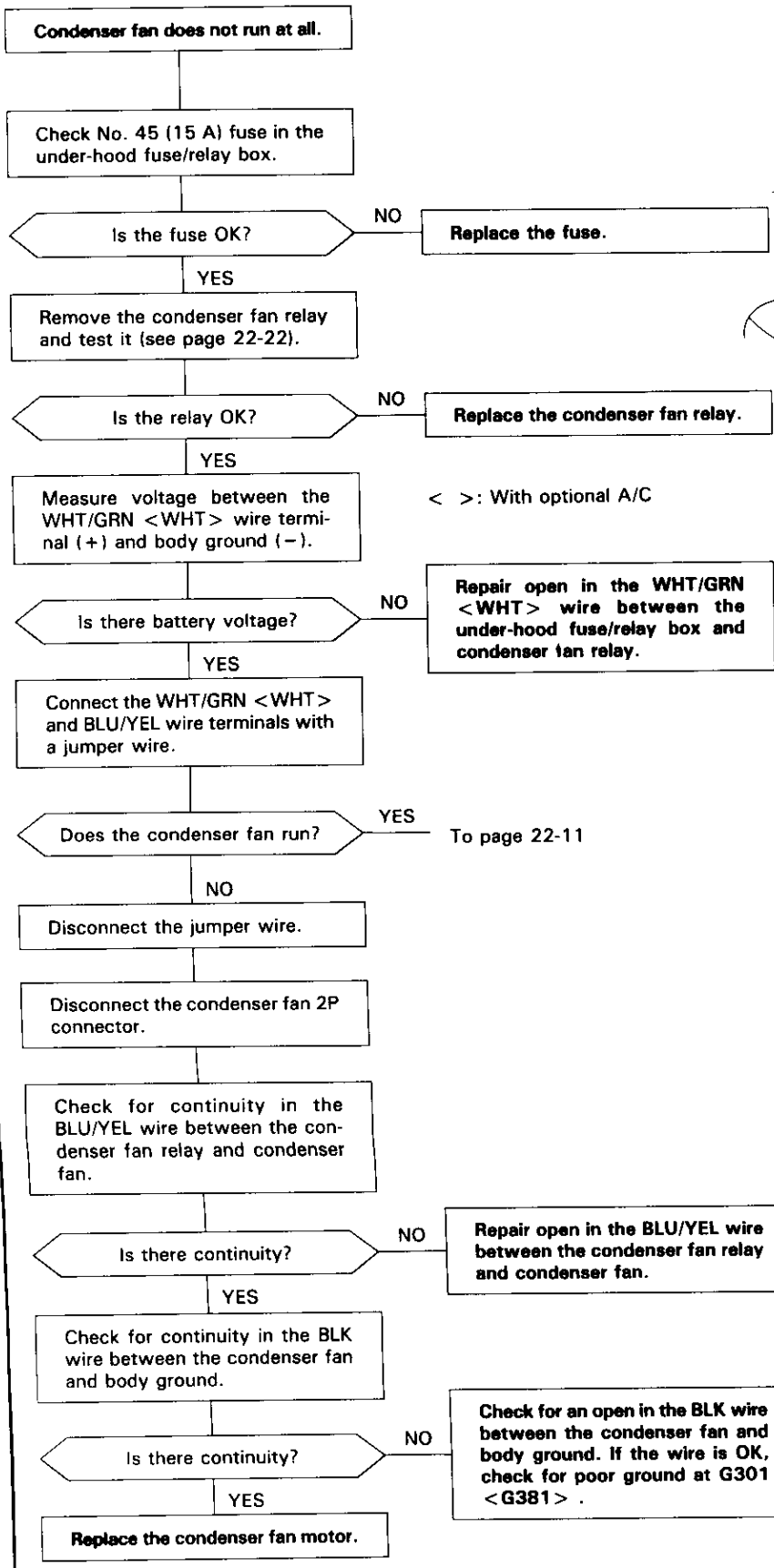



From page 22-10

Disconnect the jumper wire and turn the ignition switch ON.

Measure voltage between the YEL/WHT wire terminal (+) and body ground (-).

< >: With optional A/C

Is there battery voltage?

YES
Repair open in the BLU/RED <BLU> wire between the condenser fan relay and diode.

NO

Measure voltage between the YEL/WHT wire terminal (+) of the radiator fan control module and body ground (-).

Is there battery voltage?

NO
Perform radiator fan control module input test (see page 22-21).

YES

Repair open in the YEL/WHT wire between the condenser fan relay and radiator fan control module.

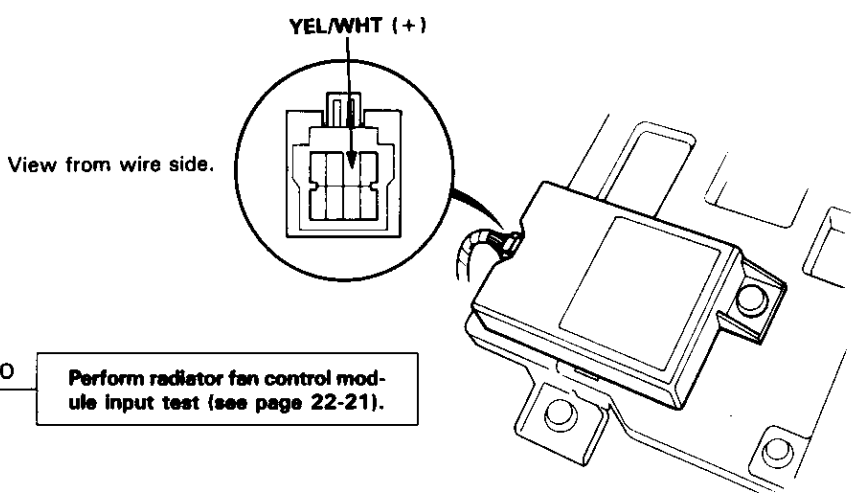

Troubleshooting

Flowchart — Engine Coolant Temperature (ECT) Switch A

Both fans (radiator and condenser) do not run for engine cooling, but they both run with the A/C on.

Disconnect the engine coolant temperature (ECT) switch A 2P connector.

Turn the ignition switch ON.

Measure voltage between the BLU/RED wire terminal (+) and body ground (-).

Is there battery voltage?

NO
Repair open in the BLU/RED wire between the ECT switch A and radiator, condenser fan relay.

YES

Turn the ignition switch OFF and check for continuity in the BLK wire between the ECT switch A and body ground.

Is there continuity?

NO
Check for an open in the BLK wire between the ECT switch A and body ground. If the wire is OK, check for poor ground at G101.

YES

Feel the lower radiator hose.

Is the hose hot?

NO
Repair the restriction in the cooling system.

YES

Replace the ECT switch A.

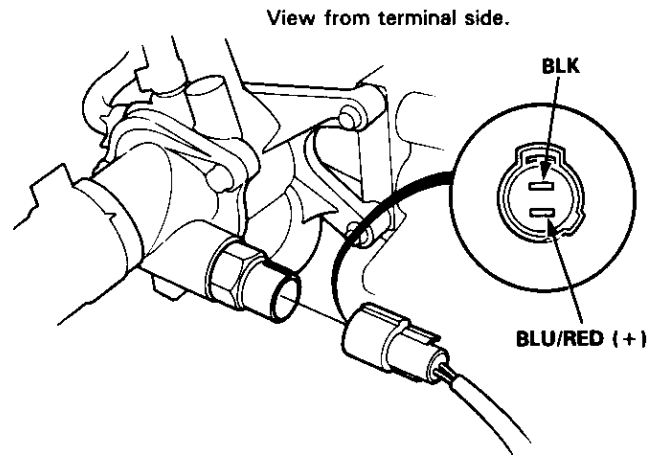

Troubleshooting

Flowchart — Both Fans



Both fans do not run at all.

Check No. 9 (15 A) in the under-dash fuse/relay box and No. 45 (15 A), No. 47 (15 A) fuse in the under-hood fuse/relay box.

Are the fuses OK?

NO

Replace the fuse(s).

YES

Disconnect the A/C pressure switch 2P connector and diode 4P connector.

Check for continuity in the BLU/BLK wire between the A/C pressure switch and diode.

Is there continuity?

NO

Repair open in the BLU/BLK wire between the A/C pressure switch and diode.

YES

Test the diode (see page 22-23).

Is the diode OK?

NO

Replace the diode.

YES

Disconnect the condenser fan relay 4P connector.

To page 22-14

View from terminal side.

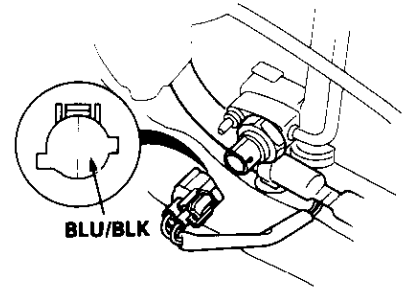

BLU/BLK

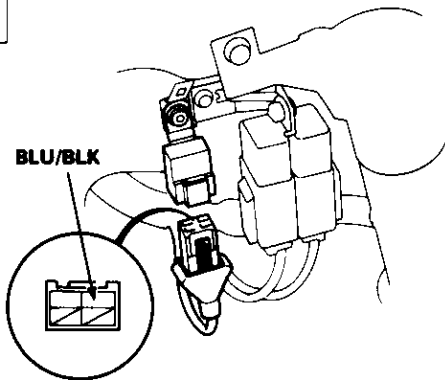

BLU/BLK

View from terminal side.

(cont'd)

Troubleshooting

Flowchart — Both Fans (cont'd)

From page 22-13

Check for continuity in the BLU/RED <BLU> wire between the diode and condenser fan relay.

< >: With optional A/C

Is there continuity?

NO

Repair open in the BLU/RED <BLU> wire between the diode and condenser fan relay.

YES

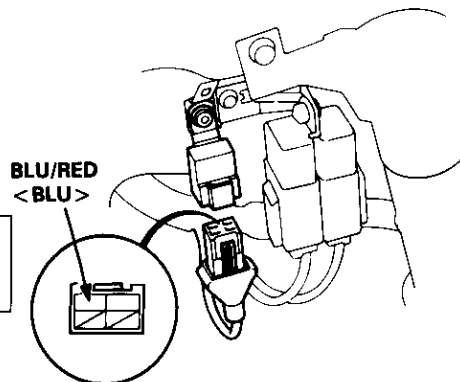

View from terminal side.

Disconnect the radiator fan control module 8P connector. Check for continuity in the BLK wire between the radiator fan control module and body ground.

Is there continuity?

NO

Check for an open in the BLK wire between the radiator fan control module and body ground. If the wire is OK, check for poor ground at G401.

YES

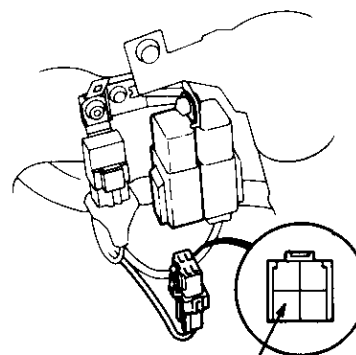

BLU/RED <BLU>

View from terminal side.

Turn the ignition switch ON.

Measure voltage between the BLK/YEL³ wire terminal (+) of radiator fan control module and body ground (-).

Is there battery voltage?

NO

Repair open in the BLK/YEL³ wire between the under-dash fuse/relay box and radiator fan control module.

YES

Replace the radiator fan control module.

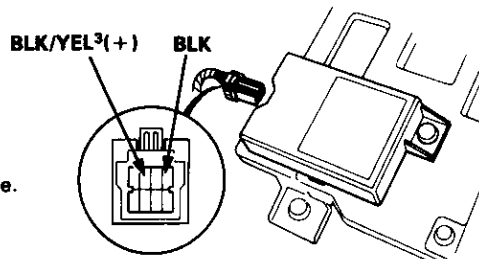

View from wire side.



Flowchart -- Compressor

Compressor clutch does not engage.

Check No. 11 (10 A) fuse in the under-dash fuse/relay box.

Is the fuse OK?

NO
Replace the fuse.

YES

Disconnect the A/C thermostat 2P connector and connect the BLU/YEL and BLU/RED wire terminals with a jumper wire.

Start the engine. Turn the A/C switch and heater fan switch ON.

Does the compressor clutch engage?

YES
Replace the A/C thermostat.

NO

Turn the ignition switch, A/C switch, and heater fan switch OFF.

Remove the compressor clutch relay and test it (see page 22-22).

Is the relay OK?

NO
Replace the compressor clutch relay.

YES

Turn the ignition switch ON.

Measure voltage between the YEL/BLK¹ < BLK/YEL¹ > wire terminal (+) and body ground (-).

Is there battery voltage?

NO
Repair open in the YEL/BLK¹ < BLK/YEL¹ > wire between the under-dash fuse/relay box and compressor clutch relay.

YES

Turn the ignition switch OFF.

To page 22-16

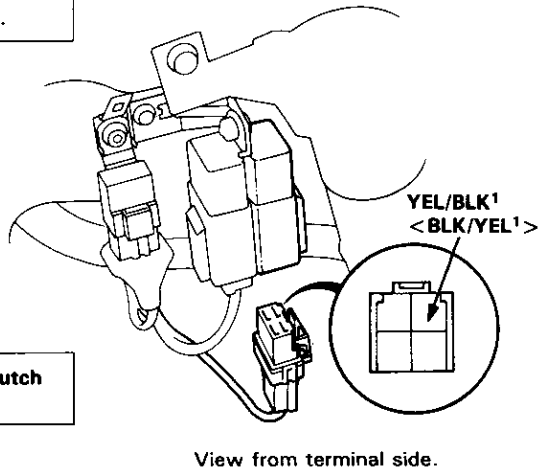
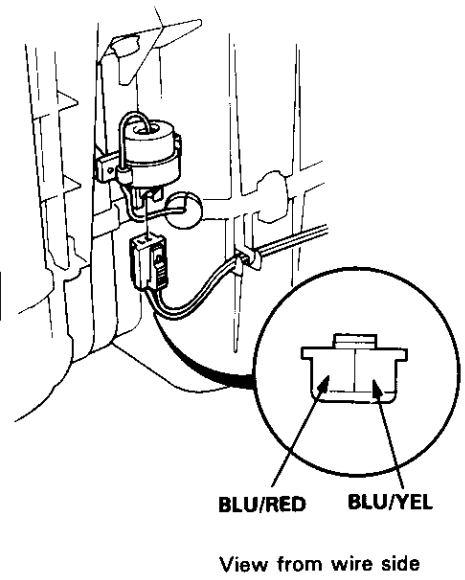

< >: With optional A/C

(cont'd)

Troubleshooting

Flowchart — Compressor (cont'd)

From page 22-15

Connect the YEL/BLK¹ <BLK/YEL¹> and RED wire terminals with a jumper wire.

< >: With optional A/C

Start the engine.

Does the compressor clutch engage?

NO

Turn the ignition switch OFF and disconnect the jumper wire.

Disconnect the compressor clutch 1P connector.

Check for continuity in the RED wire between the compressor clutch relay and compressor clutch.

Is there continuity?

NO

Repair open in the RED wire between the compressor clutch relay and compressor clutch.

YES

Inspect the compressor clutch clearance, thermal protector, and field coil (see page 22-36).

Turn the ignition switch OFF and disconnect the jumper wire.

Turn the ignition switch ON.

Measure voltage between the YEL/BLK² <BLK/YEL²> wire terminal (+) and body ground (-).

Is there battery voltage?

NO

Repair open in the YEL/BLK² <BLK/YEL²> wire between the under-dash fuse/relay box and compressor clutch relay.

YES

Turn the ignition switch OFF and install the compressor clutch relay.

To page 22-17

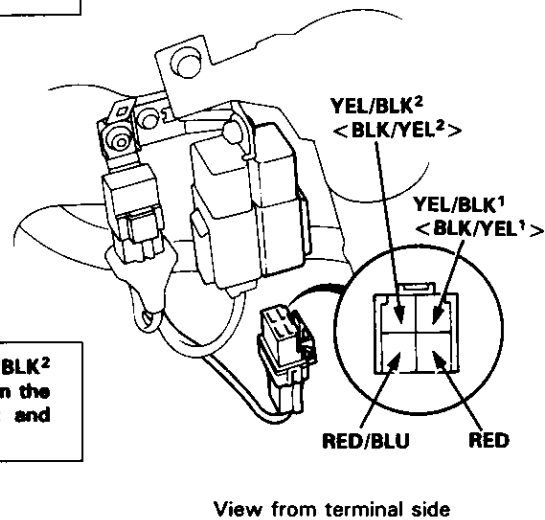
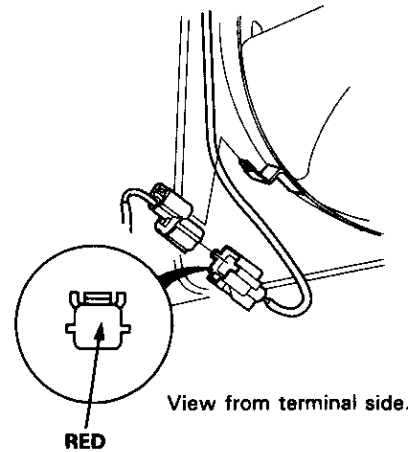



From page 22-16

Connect the test harness "A" and "B" connectors to the wire harness only, not to the ECM (see section 11).

Turn the ignition switch ON.

Measure voltage between the A 15 terminal (+) and body ground (-).

Is there battery voltage?

NO

Repair open in the RED/BLU wire between the compressor clutch relay and ECM.

YES

Make sure the A/C and heater fan switches are OFF.

Measure voltage between the B5 terminal (+) and body ground (-).

Is there battery voltage?

NO

Repair open in the BLU/BLK wire between the diode and ECM.

YES

Substitute a known-good ECM and recheck. If symptom/indication goes away, replace the original ECM.

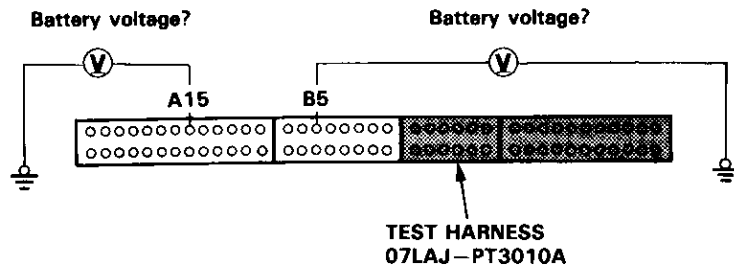

Troubleshooting

Flowchart — A/C System

NOTE: First, check for refrigerant pressure.

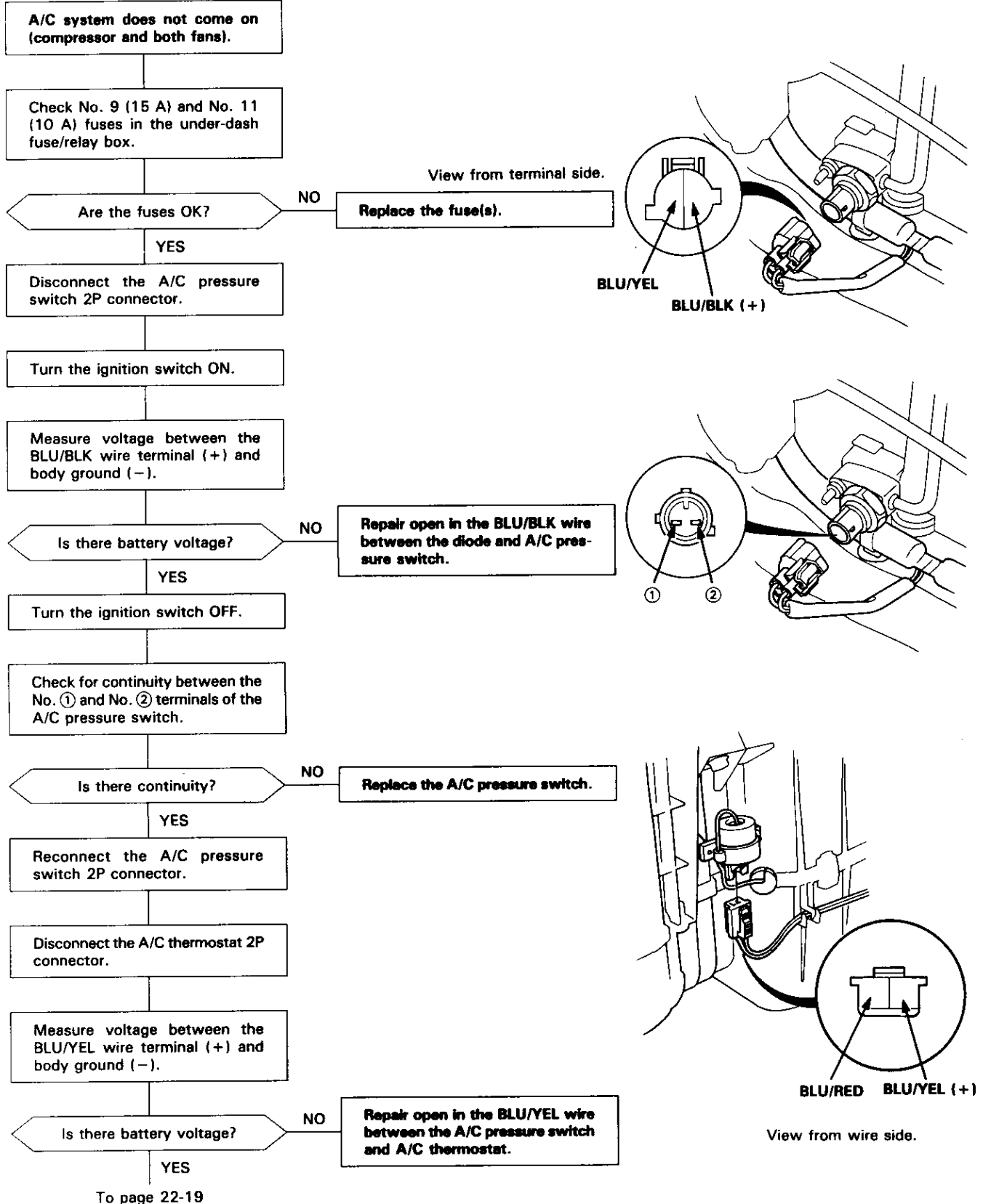



From page 22-18

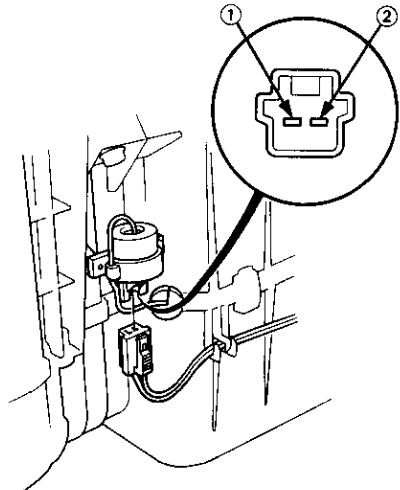
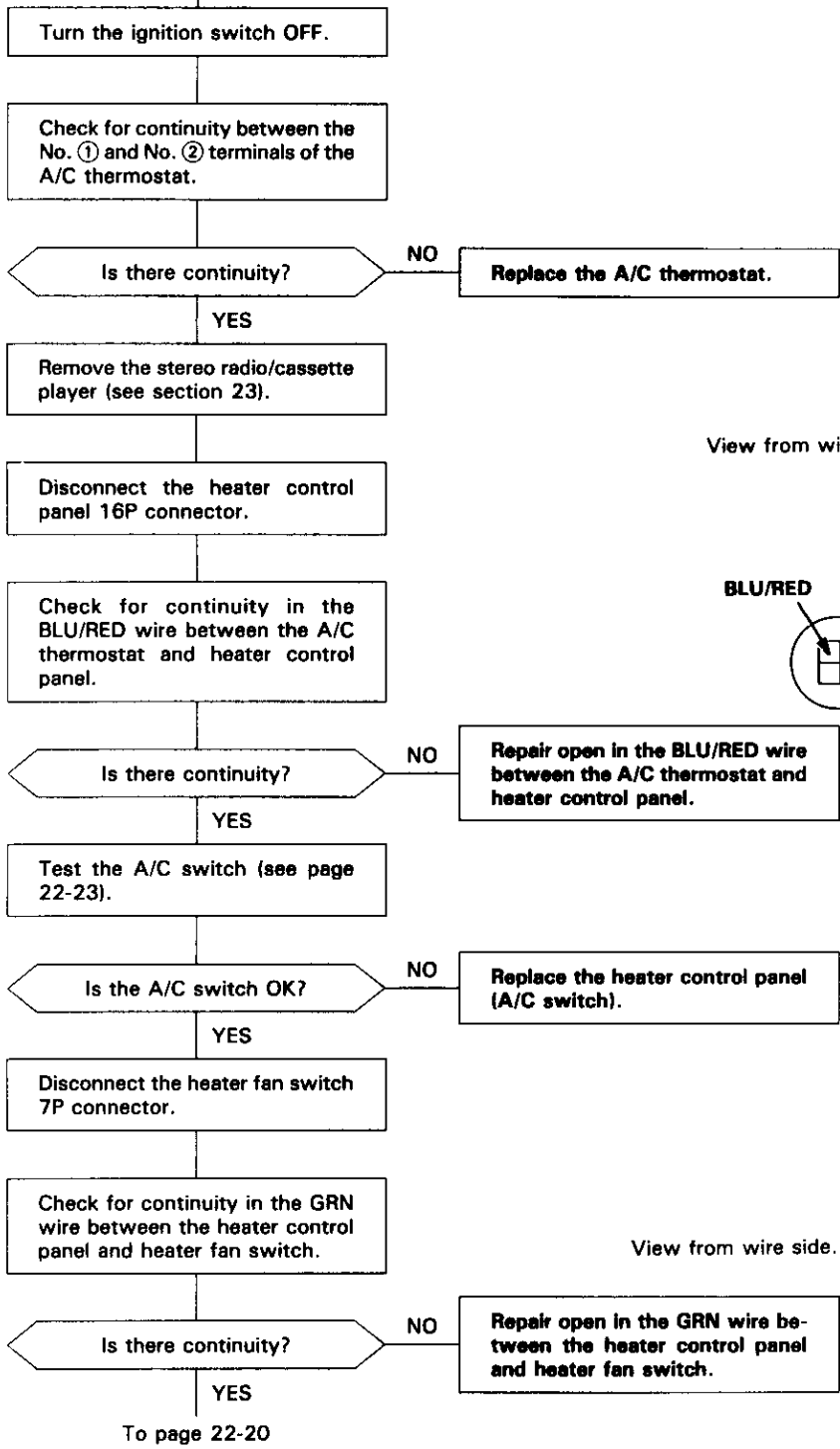

View from wire side.

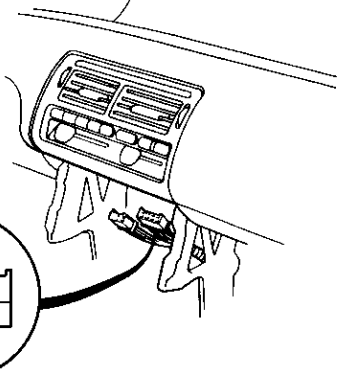
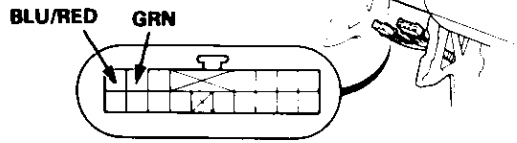

View from wire side.

(cont'd)

Troubleshooting

Flowchart — A/C System (cont'd)

From page 22-19

Check for continuity in the BLK wire between the heater fan switch and body ground.

Is there continuity?

NO

YES

Replace the heater fan switch.

Check for an open in the BLK wire between the heater fan switch and body ground. If the wire is OK, check for poor ground at G402.

View from wire side.

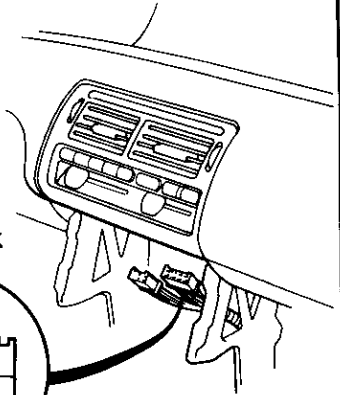
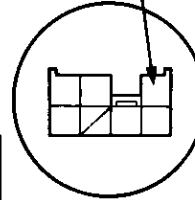



Radiator Fan Control Module Input Tests

NOTE: Perform the following tests with the radiator fan control module connected and the ignition switch ON and the A/C switch OFF.

If you find the cause of a problem, correct it before you continue.

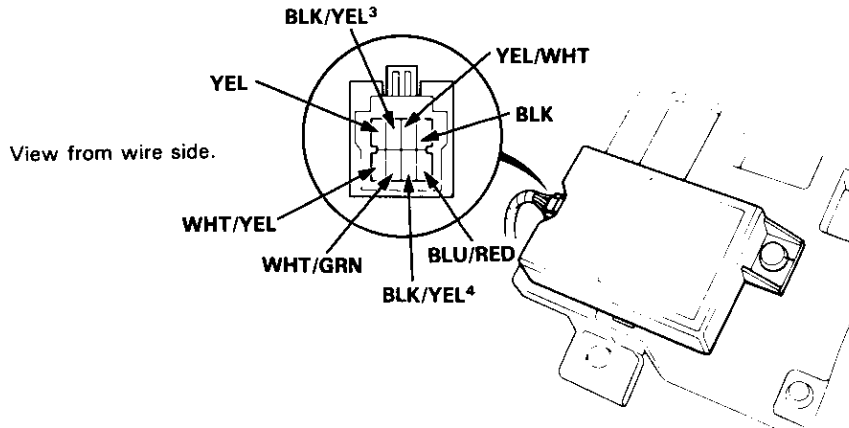

WIRE COLOR	TEST CONDITION	DESIRED RESULTS	CORRECTIVE ACTION IF DESIRED RESULTS ARE NOT OBTAINED
BLK	Check for voltage to body ground.	Should have less than one volt.	Repair open to body ground.
WHT/GRN	Check for battery voltage.	Should have battery voltage.	Check No. 45 (15 A) fuse in the underhood fuse/relay box; if OK, repair open in the WHT/GRN wire.
BLK/YEL ⁴	Check for battery voltage. (Ignition switch—ON.)		Check No. 23 (15 A) fuse in the underdash fuse/relay box; if OK, repair open in the BLK/YEL ² wire.
BLK/YEL ³	Check for battery voltage. (Ignition switch—ON.)		Check No. 9 (15 A) fuse in the underdash fuse/relay box; if OK, repair open in the BLK/YEL ¹ wire.
YEL/WHT	Check for battery voltage. (Ignition switch—ON.)		Replace radiator fan control module. Before you connect the new radiator fan control module, disconnect both fan relays. Check for continuity between the YEL/WHT (or YEL) wire and ground, using the 20 k scale on your ohmmeter. There should be no continuity. If there is continuity, the new radiator fan control module will be damaged when you connect it.
YEL	Check for battery voltage. (Ignition switch—ON.)		
BLU/RED	Connect to body ground. (Ignition switch—ON.)	Condenser fan and radiator fan should come on. Engine coolant temperature; below 199°F [93°C]: F22A1/H23A1 engine below 203°F [95°C]: H22A1 engine	Check for an open in the BLU/RED wire between the radiator fan control module and condenser fan relay or radiator fan relay. If OK, check for an open in the YEL/WHT wire between the radiator fan control module and condenser fan relay or the YEL wire between the radiator fan control module and radiator fan relay. If OK, test condenser fan relay or radiator fan relay.
WHT/YEL	Check for voltage.	Approx. 11 V (engine coolant temperature below 223°F [106°C])	Faulty engine coolant temperature (ECT) switch B, short to body ground or faulty radiator fan control module.

A/C Thermostat

Test

Dip the A/C thermostat into a cup filled with ice water, and check for continuity between the terminals.

Cut off 35 — 31°F (1.5 — -0.5°C)
Cut in 36 — 41°F (2.5 — 5°C)

If cut off or cut in temperature is too low or too high, replace the A/C thermostat.

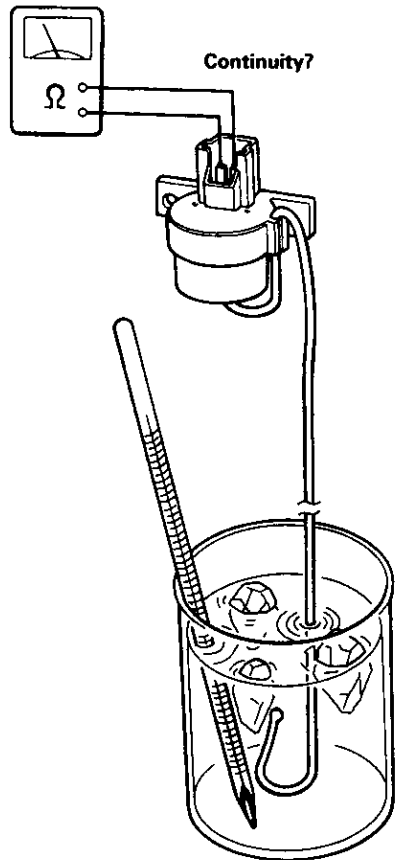

Relays

Test

There should be continuity between the C and D terminals.

There should be continuity between the A and B terminals when power and ground are connected to the C and D terminals.

There should be no continuity when power is disconnected.

- Radiator fan relay

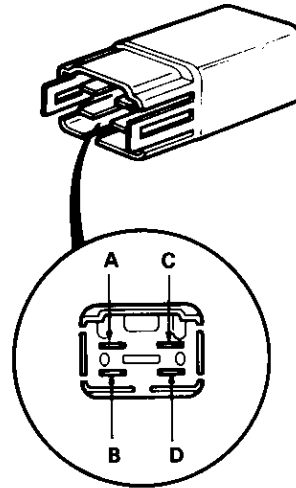

- Condenser fan relay
- Compressor clutch relay

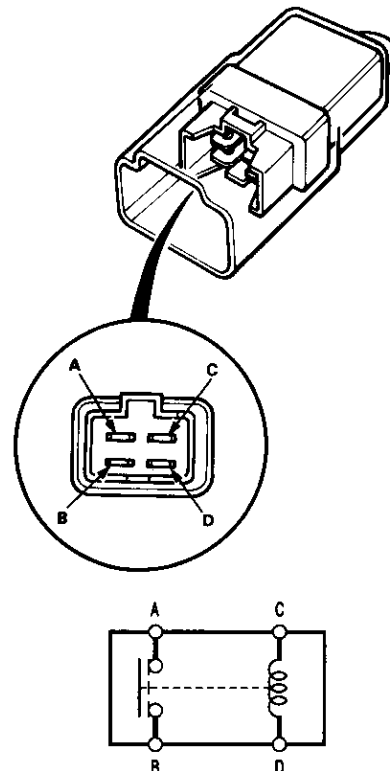



Diode

Test

NOTE: The diodes are designed to pass current in one direction while blocking if in the opposite direction. Most ohmmeters, unless equipped with a diode tester, should not be used to test diodes.

Check for continuity in both directions between the A and B terminals. There should be continuity in only one direction.

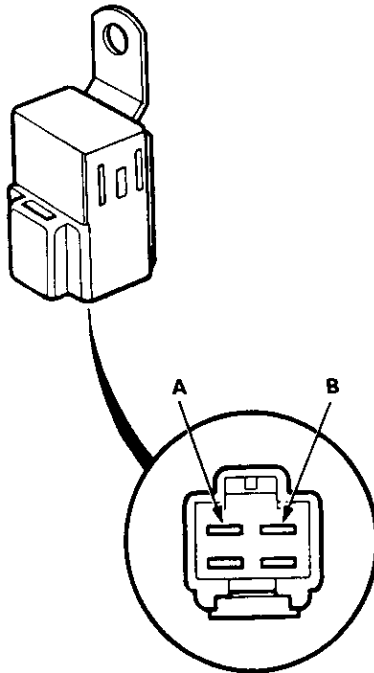

A/C Switch

Test

Check for continuity between the terminals according to the table below.

Terminal Position	1	2
ON		
OFF		

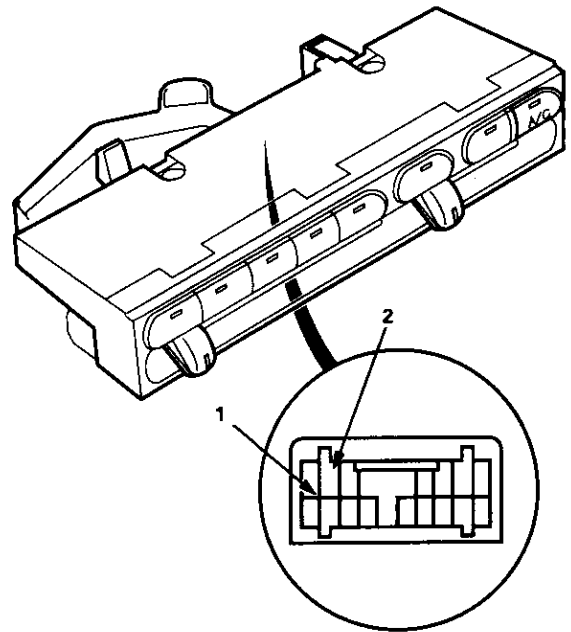

A/C Service Tips and Precautions

The air conditioning system uses R-134a refrigerant and polyalkylene glycol (PAG) refrigerant oil, which are not compatible with R-12 refrigerant and mineral oil. Do not use R-12 refrigerant or mineral oil in this system, and do not attempt to use R-12 servicing equipment; damage to the air conditioning system or your servicing equipment will result.

Only use service equipment that is U.L.-listed and is certified to meet the requirements of SAE J2210 to remove R-134a from the air conditioner system.

CAUTION: Exposure to air conditioner refrigerant and lubricant vapor or mist can irritate eyes, nose and throat. Avoid breathing the air conditioner refrigerant and lubricant vapor or mist.

If accidental system discharge occurs, ventilate work area before resuming service.

R-134a service equipment or vehicle air conditioner systems should not be pressure tested or leak tested with compressed air.

WARNING Some mixture of air and R-134a have been shown to be combustible at elevated pressures and can result in fire or explosion causing injury or property damage. Never use compressed air to pressure test R-134a service equipment or vehicle air conditioner systems.

Additional health and safety information may be obtained from the refrigerant and lubricant manufacturers.

1. Always disconnect the negative cable from the battery whenever replacing air conditioning parts.
2. Keep moisture and dust out of the system. When disconnecting any lines, plug or cap the fittings immediately; don't remove the caps or plugs until just before you reconnect each line.
3. Before connecting any hose or line, apply a few drops of refrigerant oil (SP-10; P/N 38899-P13-003) to the O-ring.
4. When tightening or loosening a fitting, use a second wrench to support the matching fitting.
5. When recovering the system, use a R-134a refrigerant Recovery/Recycling/Charging System; don't release refrigerant into the atmosphere.
6. Add refrigerant oil (SP-10; P/N 38899-P13-003) after replacing the following parts:

NOTE:

- Do not return the oil to the container once dispensed and never mix with other refrigerant oils to avoid contamination.
- Immediately after using the oil, replace the cap on the container and seal it to avoid moisture absorption.
- Do not spill the refrigerant oil on the car; it may damage the paint; if the refrigerant oil contacts the paint, wash it off immediately.

Condenser	10 cc (1/3 fl oz)
Evaporator	30 cc (1 fl oz)
Line or hose	10 cc (1/3 fl oz)
Receiver/dryer	10 cc (1/3 fl oz)
Compressor	On compressor replacement, subtract the volume of oil drained from the removed compressor from 120 cc (4 fl oz), and drain the calculated volume of oil from the new compressor: 120 cc (4 fl oz) — Volume of oil from removed compressor = Volume to drain from new compressor.

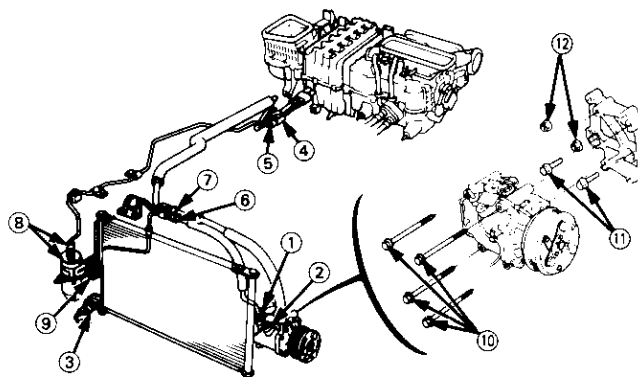

① Discharge hose nut (8 x 1.25 mm)	22 N-m (2.2 kg-m, 16 lb-ft)
② Suction hose bolt (8 x 1.25 mm)	22 N-m (2.2 kg-m, 16 lb-ft)
③ Condenser pipe nut (6 x 1.0 mm)	10 N-m (1.0 kg-m, 7 lb-ft)
④ Receiver pipe bolts (6 x 1.0 mm)	10 N-m (1.0 kg-m, 7 lb-ft)
⑤ Suction pipe nut (6 x 1.0 mm)	10 N-m (1.0 kg-m, 7 lb-ft)
⑥ Discharge pipe joint nut	23 N-m (2.3 kg-m, 17 lb-ft)
⑦ Suction pipe joint nut	33 N-m (3.3 kg-m, 24 lb-ft)
⑧ Receiver/dryer	14 N-m (1.4 kg-m, 10 lb-ft)
⑨ Discharge pipe nut (6 x 10 mm)	10 N-m (1.0 kg-m, 7 lb-ft)
⑩ Compressor mounting bolts (8 x 1.25 mm)	22 N-m (2.2 kg-m, 16 lb-ft)
⑪ Compressor bracket mounting bolts (10 x 1.25 mm)	50 N-m (5.0 kg-m, 36 lb-ft)
⑫ Compressor bracket mounting nuts (10 x 1.25 mm)	50 N-m (5.0 kg-m, 36 lb-ft)

A/C System Service



Recovery

Only use service equipment that is U.L.-listed and is certified to meet the requirements of SAE J2210 to remove R-134a from the air conditioner system.

CAUTION: Exposure to air conditioner refrigerant and lubricant vapor or mist can irritate eyes, nose and throat. Avoid breathing the air conditioner refrigerant and lubricant vapor or mist.

If accidental system discharge occurs, ventilate work area before resuming service.

R-134a service equipment or vehicle air conditioner systems should not be pressure tested or leak tested with compressed air.

⚠ WARNING Some mixture of air and R-134a have been shown to be combustible at elevated pressures and can result in fire or explosion causing injury or property damage. Never use compressed air to pressure test R-134a service equipment or vehicle air conditioner systems.

Additional health and safety information may be obtained from the refrigerant and lubricant manufacturers.

1. Connect a R-134a refrigerant Recovery/Recycling/Charging System to the car as shown following the equipment manufacturer's instructions.
2. Measure the amount of refrigerant oil removed from the A/C system after the recovery process is completed.

NOTE: Be sure to install the same amount of new refrigerant oil back into the A/C system before charging.

Recovery/Recycling/Charging System.

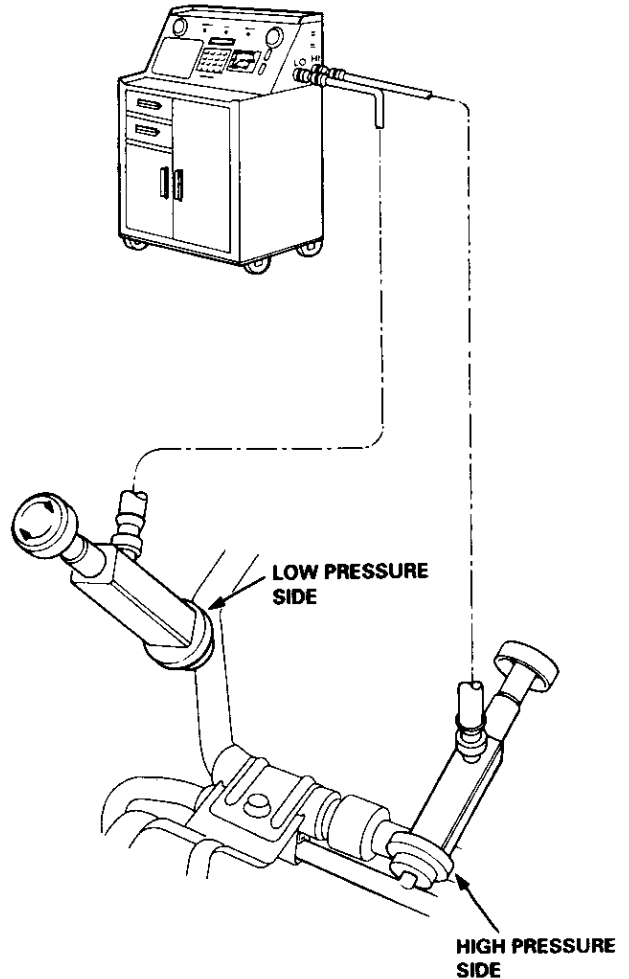

A/C System Service

Performance Test

The performance test will help determine if the air conditioner system is operating within specifications.

Only use service equipment that is U.L.-listed and is certified to meet the requirements of SAE J2210 to remove R-134a from the air conditioner system.

CAUTION: Exposure to air conditioner refrigerant and lubricant vapor or mist can irritate eyes, nose and throat. Avoid breathing the air conditioner refrigerant and lubricant vapor or mist.

If accidental system discharge occurs, ventilate work area before resuming service.

R-134a service equipment or vehicle air conditioner systems should not be pressure tested or leak tested with compressed air.

⚠ WARNING Some mixture of air and R-134a have been shown to be combustible at elevated pressures and can result in fire or explosion causing injury or property damage. Never use compressed air to pressure test R-134a service equipment or vehicle air conditioner systems.

Additional health and safety information may be obtained from the refrigerant and lubricant manufacturers.

1. Connect a R-134a refrigerant Recovery/Recycling/Charging System to the car as shown following the equipment manufacturer's instructions.
2. Insert a thermometer in the center vent outlet. Determine the relative humidity and air temperature by calling the local weather information line.
3. Test conditions:
 - Avoid direct sunlight.
 - Open hood.
 - Open front doors.
 - Set the temperature control lever to MAX COOL and push the mode control button to VENT and push the recirculation control button to RECIRC.
 - Slide the fan switch to MAX.
 - Run the engine at 1,500 rpm.
 - No driver or passengers in vehicle.
4. After running the air conditioning for 10 minutes under the above test conditions, read the delivery temperature from the thermometer in the dash vent and the high and low system pressure from the A/C gauges.

Recovery/Recycling/Charging System

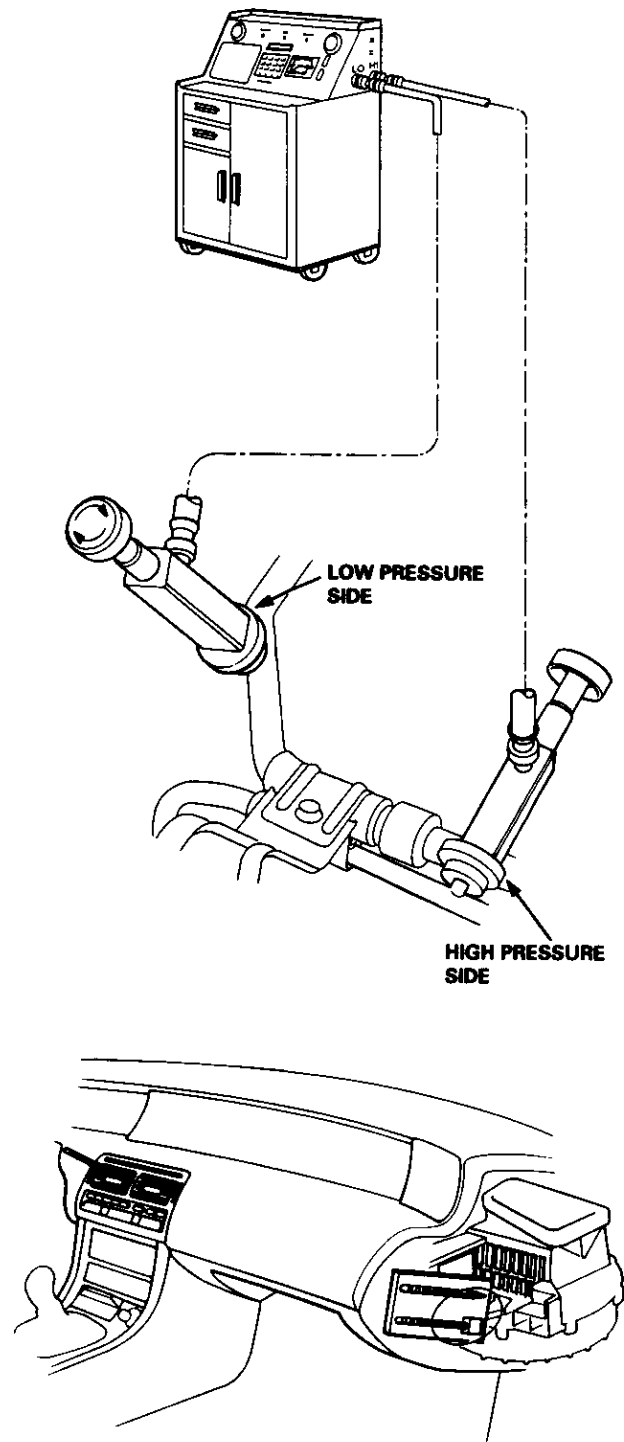



5. To complete the charts:

- Mark the delivery temperature along the vertical line.
- Mark the intake temperature (ambient air temperature) along the bottom line.
- Draw a line straight up from the air temperature to the humidity.
- Mark a point one line above and one line below the humidity level (10% above and 10% below the humidity level).
- From each point, draw a horizontal line across the delivery temperature.
- The delivery temperature should fall between the two lines.
- Complete the low side pressure test and high side pressure test in the same way.
- Any measurements outside the line may indicate the need for further inspection.

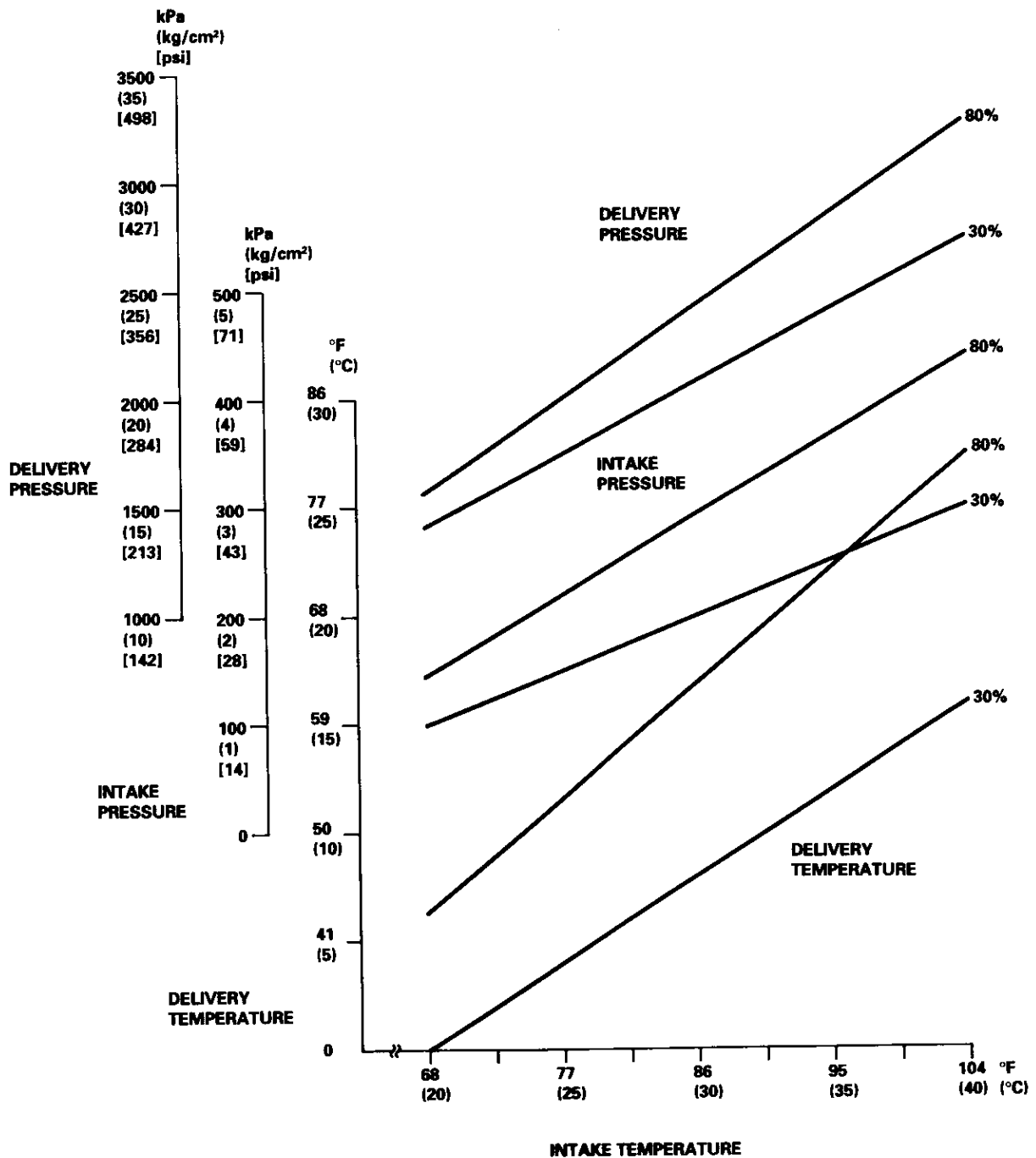

A/C System Service

Pressure Test Chart

NOTE: Performance Test on page 22-26.

TEST RESULTS	RELATED SYMPTOMS	PROBABLE CAUSE	REMEDY
Discharge (high) pressure abnormally high	After stopping compressor, pressure drops to about 200 kPa (2.0 kg/cm ² , 28 psi) quickly, and then falls gradually.	Air in system	Recover, evacuate and recharge with specified amount. Evacuation: see page 22-42 Charging: see page 22-43
	No bubbles in sight glass when condenser is cooled by water.	Excessive refrigerant in system	Recover, evacuate and recharge with specified amount.
	Reduced or no air flow through condenser.	<ul style="list-style-type: none"> • Clogged condenser or radiator fins • Condenser or radiator fan not working properly 	<ul style="list-style-type: none"> • Clean • Check voltage and fan rpm • Check fan direction
	Line to condenser is excessively hot.	Restricted flow of refrigerant in system	• Restricted lines
Discharge pressure abnormally low	Excessive bubbles in sight glass; condenser is not hot.	Insufficient refrigerant in system	<ul style="list-style-type: none"> • Check for leak • Charge system
	High and low pressures are balanced soon after stopping compressor. Low side is higher than normal.	<ul style="list-style-type: none"> • Faulty compressor discharge valve • Faulty compressor seal 	Replace the compressor
	Outlet of expansion valve is not frosted, low pressure gauge indicates vacuum.	<ul style="list-style-type: none"> • Faulty expansion valve • Moisture in system 	<ul style="list-style-type: none"> • Replace • Flush, recover, evacuate and recharge with specified amount.
Suction (low) pressure abnormally low	Excessive bubbles in sight glass; condenser is not hot.	Insufficient refrigerant	Repair the leaks. Recover, evacuate and recharge with specified amount. Charge as required.
	Expansion valve is not frosted and low pressure line is not cold. Low pressure gauge indicates vacuum.	<ul style="list-style-type: none"> • Frozen expansion valve • Faulty expansion valve 	Replace the expansion valve
	Discharge temperature is low and the air flow from vents is restricted.	Frozen evaporator	Run the fan with compressor off then check A/C thermostat
	Expansion valve is frosted.	Clogged expansion valve	Clean or replace
	Receiver/dryer outlet is cool and inlet is warm (should be warm during operation).	Clogged receiver/dryer	Replace
Suction pressure abnormally high	Low pressure hose and check joint are cooler than the temperature around evaporator.	<ul style="list-style-type: none"> • Expansion valve open too long • Loose expansion capillary tube 	Repair or replace.
	Suction pressure is lowered when condenser is cooled by water.	Excessive refrigerant in system	Recover, evacuate and recharge with specified amount.
	High and low pressure are equalized as soon as the compressor is stopped and both gauges fluctuate while running.	<ul style="list-style-type: none"> • Faulty gasket • Faulty high pressure valve • Foreign particle stuck in high pressure valve 	Replace the compressor
Suction and discharge pressures abnormally high	Reduced air flow through condenser.	<ul style="list-style-type: none"> • Clogged condenser or radiator fins • Condenser or radiator fan not working properly 	<ul style="list-style-type: none"> • Clean condenser and radiator • Check voltage and fan rpm • Check fan direction
	No bubbles in sight glass when condenser is cooled by water.	Excessive refrigerant in system	Recover, evacuate and recharge with specified amount
Suction and discharge pressure abnormally low	Low pressure hose and metal end areas are cooler than evaporator.	Clogged or kinked low pressure hose parts	Repair or replace
	Temperature around expansion valve is too low compared with that around receiver/dryer.	Clogged high pressure line	Repair or replace
Refrigerant leaks	Compressor clutch is dirty.	Compressor shaft seal leaking	Replace the compressor
	Compressor bolt(s) are dirty.	Leaking around bolt(s)	Tighten bolt(s) or replace compressor
	Compressor gasket is wet with oil.	Gasket leaking	Replace the compressor
Compressor heat damage	Black soot inside compressor and hoses.	Restriction or leak in system	Flush entire system, replace rubber lines or hoses

Evaporator

Replacement

▲ CAUTION Store a removed airbag assembly with the pad face up. If the airbag is improperly stored with the pad face down, accidental deployment could propel the unit with enough force to cause serious injury.

CAUTION:

- All SRS electrical wiring harnesses are covered with yellow outer insulation.
- Before disconnecting the SRS wire harness, install the short connector(s) on the airbag(s) (see page 23-294).
- Replace the entire affected SRS harness assembly if it has an open circuit or damaged wiring.

NOTE: The radio may have a coded theft protection circuit. Be sure to get the customer's code number before:

- Disconnecting the battery.
- Removing the No. 43 (10 A) fuse in the under-hood fuse/relay box.
- Removing the radio.

After service, reconnect power to the radio and turn it on.

When the word "CODE" is displayed, enter the customer's 5-digit code to restore radio operation.

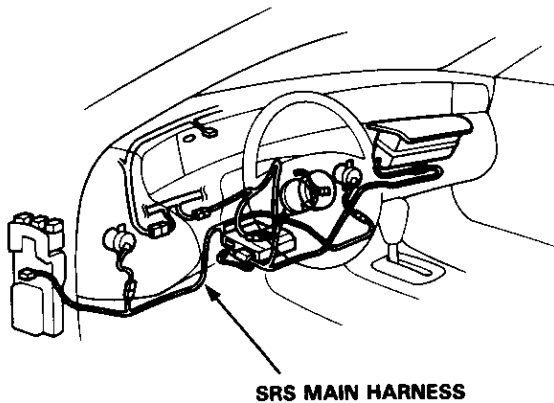

1. Disconnect the battery negative cable, then disconnect the positive cable.
2. Recover the refrigerant (see page 22-25).
3. Remove the bolt and disconnect the receiver line from the evaporator.
4. Remove the nut and disconnect the suction line from the evaporator.

CAUTION: Cap the open fittings immediately to keep moisture out of the system.

6 x 1.0 mm
10 N-m (1.0 kg-m, 7 lb-ft)

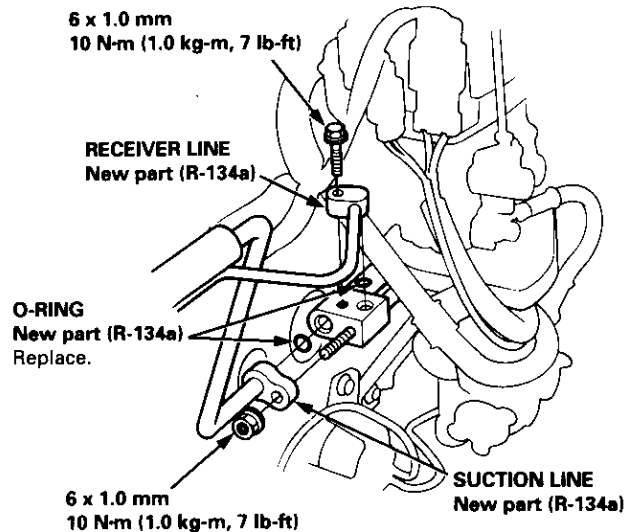

5. Remove the right tweeter from the dashboard, then remove the visor and black face panel (see page 23-130).
6. Remove the glove box, then remove the four mounting nuts from the front passenger's airbag assembly.
7. Carefully lift the front passenger's airbag assembly out of the dashboard.

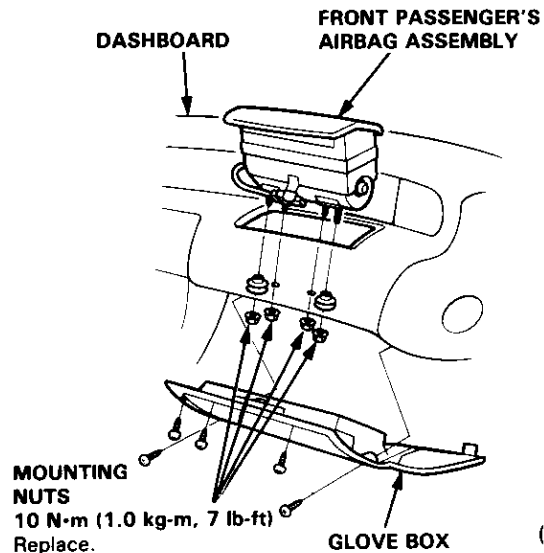

(cont'd)

Evaporator

Replacement (cont'd)

8. Remove the four TORX bolts and front passenger's airbag frame.

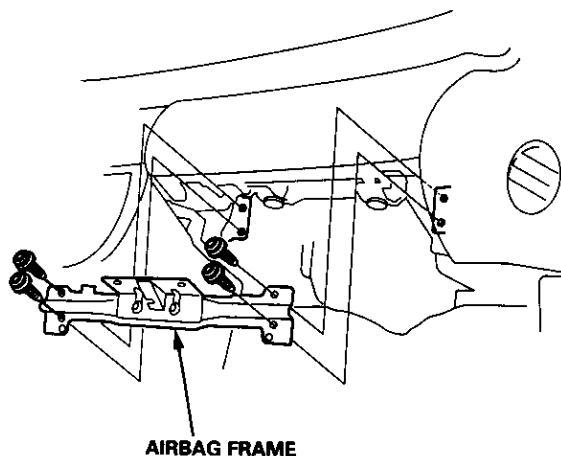

9. Remove the four self-tapping screws and front passenger's airbag bracket.

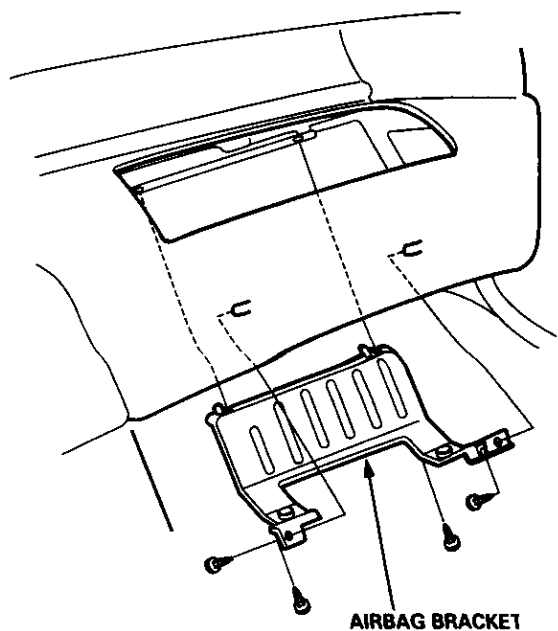

10. Disconnect the connector from the A/C thermostat.
11. Remove the four self-tapping screws, bolt, and two nuts, then remove the evaporator.

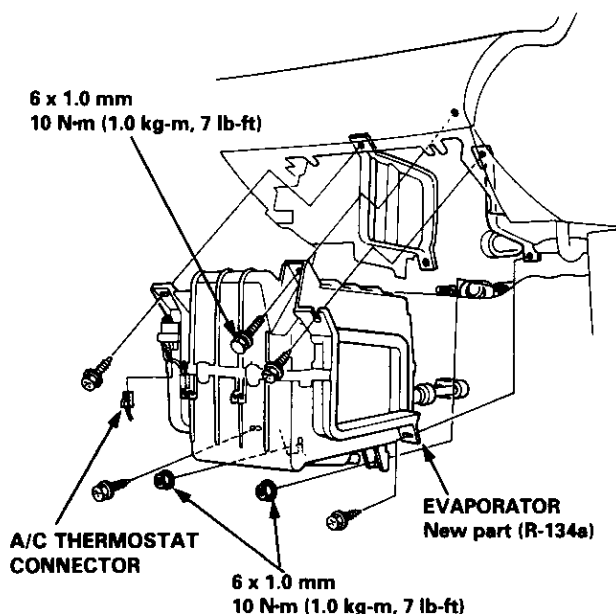

12. Install in the reverse order of removal, and:

- If you're installing a new evaporator, add refrigerant oil (SP-10: P/N 38899-P13-003) (see page 22-24).
- Replace O-rings with new ones at each fitting, and apply a thin coat of refrigerant oil (SP-10: P/N 38899-P13-003) before installing them.

NOTE: Be sure to use the right O-rings for R-134a to avoid leakage.

- See page 23-320 before reinstalling the front passenger's airbag.
- Apply a sealant to the grommets.
- Make sure that there is no air leakage.
- Charge the system (see page 22-43) and test performance (see page 22-26).



Overhaul

1. Pull the A/C thermostat sensor out of the evaporator fins.
2. Remove the self-tapping screws and clips from the housing.
3. Carefully separate the housings and remove the evaporator.
4. Remove the expansion valve if necessary.

NOTE: When loosening the expansion valve nuts, use a second wrench to hold the valve or evaporator pipe or they can be cracked.

Assemble in the reverse order of disassembly, and:

- Replace all O-rings with new ones at each fitting, and apply a thin coat of refrigerant oil (SP-10; P/N 38899-P13-003) before installing them.

NOTE: Be sure to use the right O-rings for R-134a to avoid leakage.

- Install the expansion valve capillary tube with the capillary tube in contact with the suction line directly, and wrap it with tape.
- Reinstall the A/C thermostat sensor in its original location.

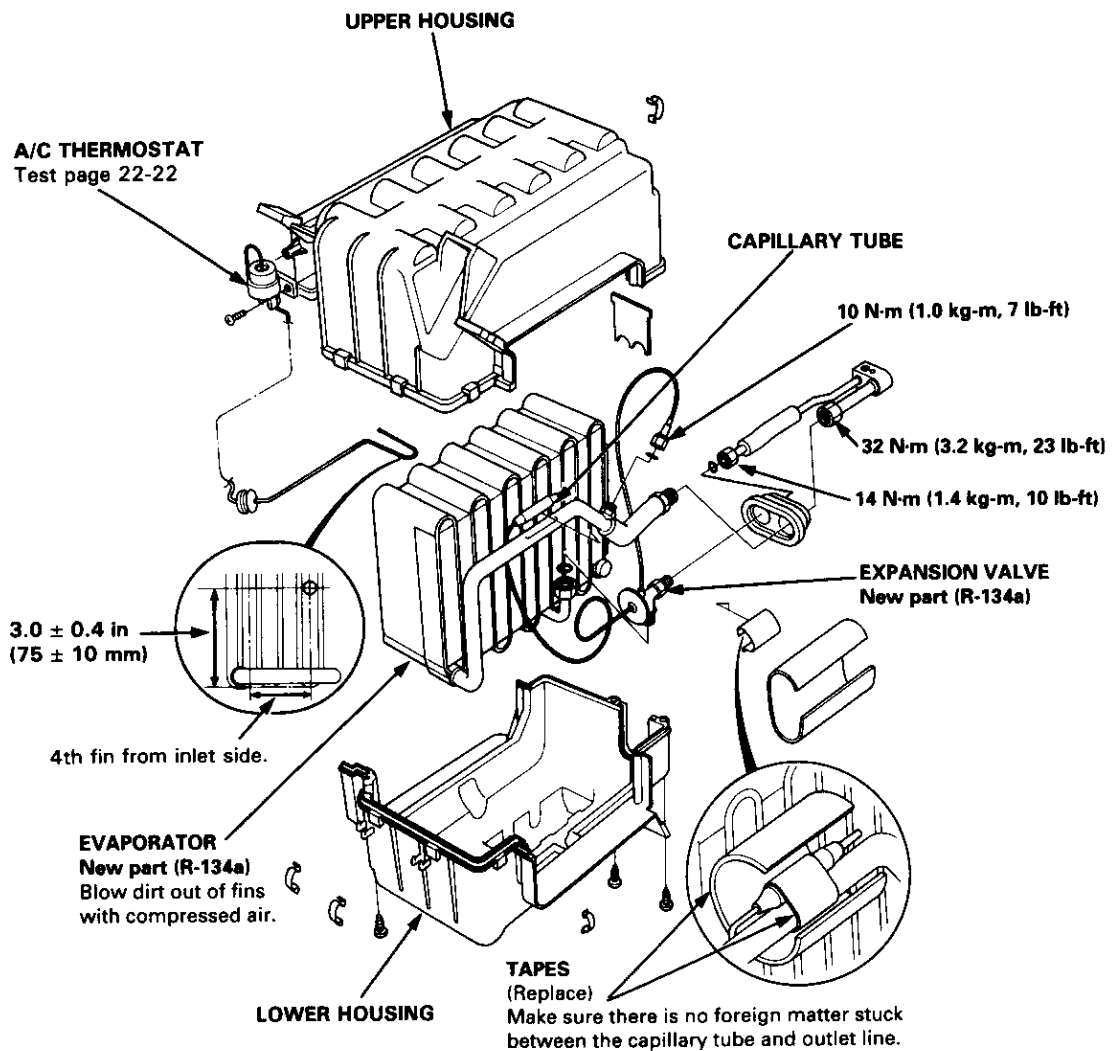

Compressor

Description

This compressor is a Sanden spiral type for R-134a. Refrigerant is compressed between a fixed spiral assembly and an orbiting spiral assembly. A thermal protector is installed on this compressor.

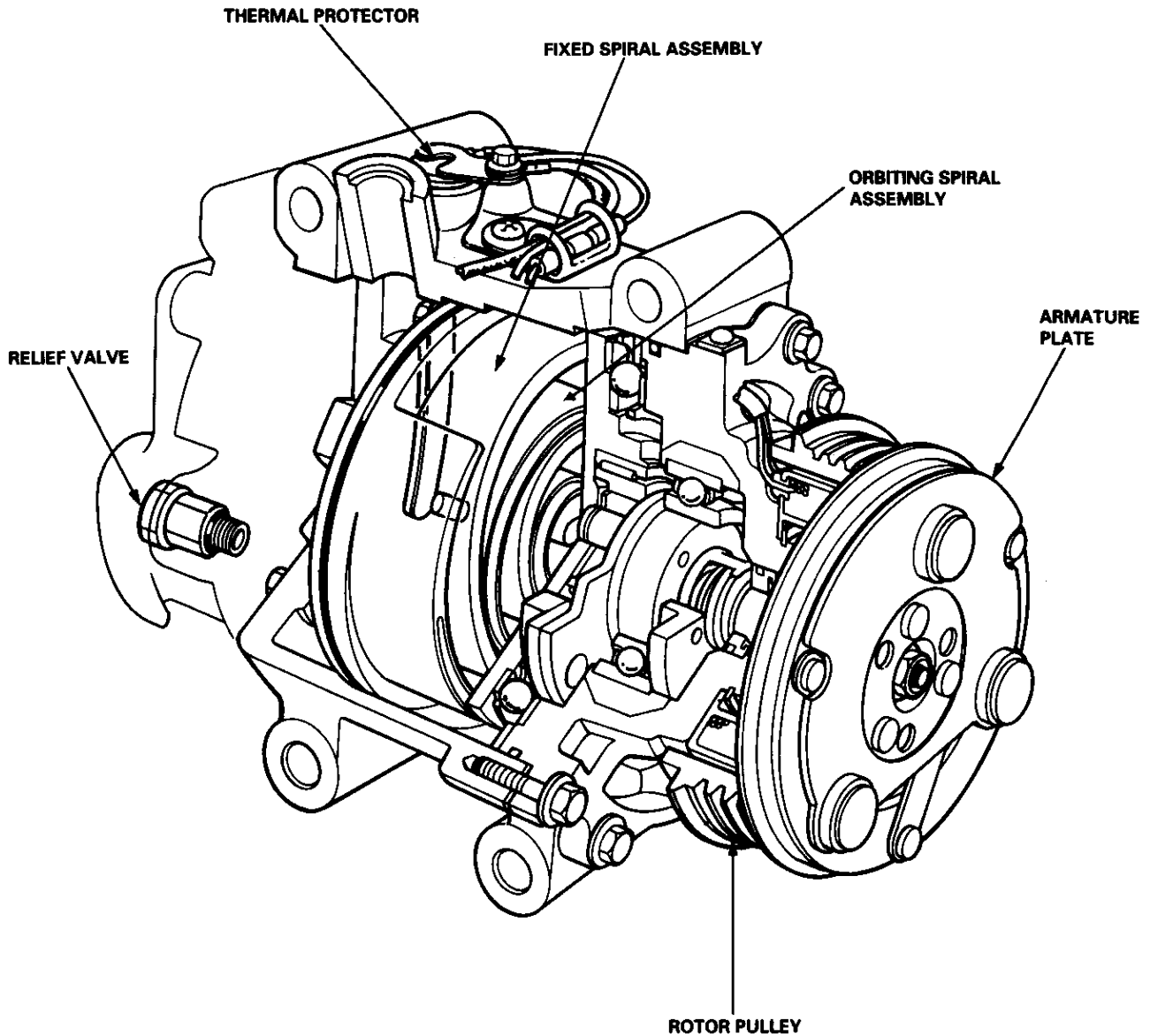



Illustrated Index

Check the plated parts of the armature plate for color changes, peeling or other damage. If there is damage, replace the clutch set.

Turn the rotor pulley and check for excessive bearing play or drag. If there is excessive play or drag, replace the clutch set.

Check resistance by connecting an ohmmeter to the field coil wire and the compressor body. Field Coil Resistance: 3.2 ± 0.15 ohm at 68°F (20°C). If resistance is not within specifications, replace the field coil.

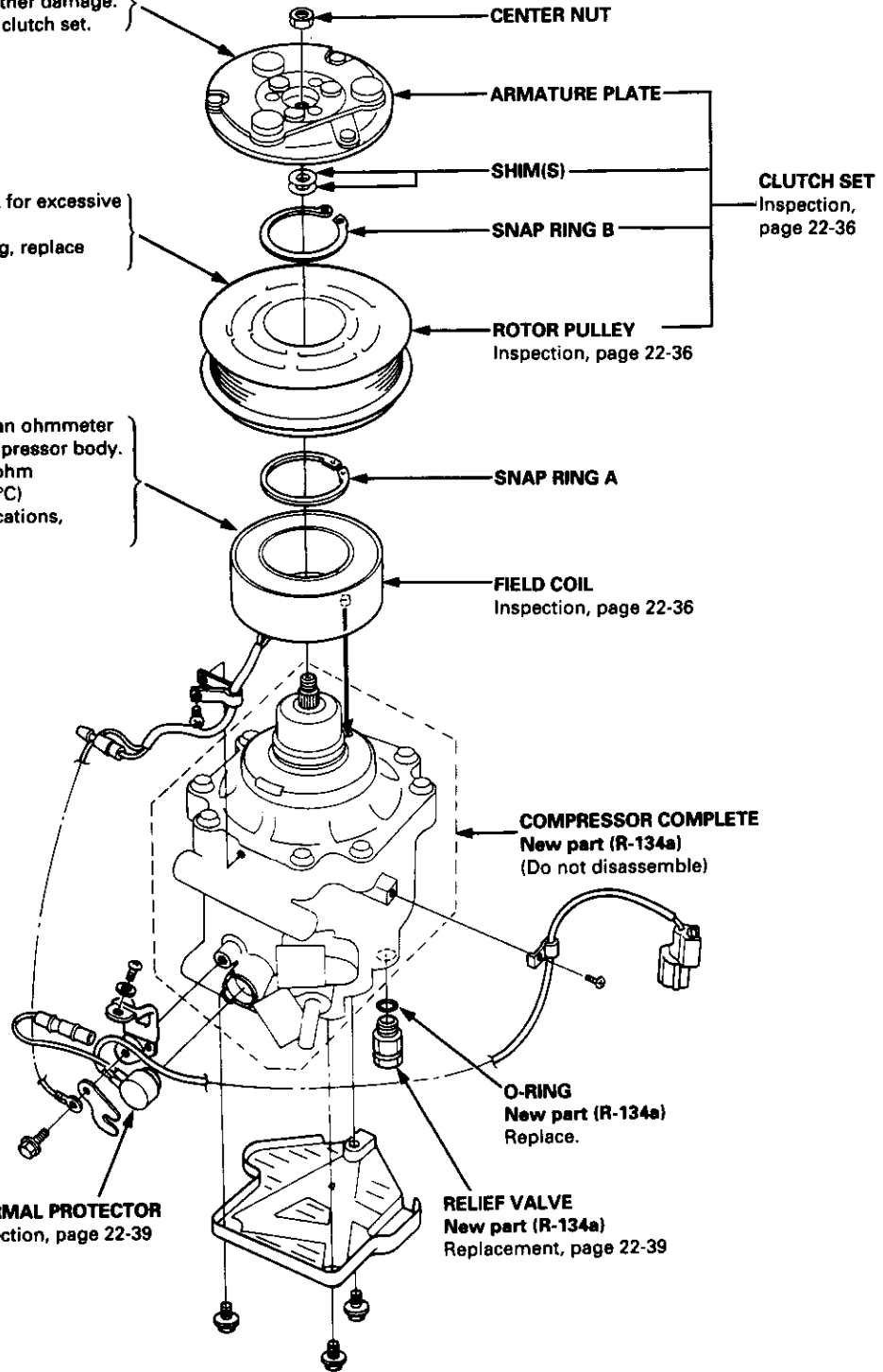

Compressor

Replacement

1. If the compressor is marginally operable, run the engine at idle speed and turn the air conditioner fan on for a few minutes, then shut the engine off and disconnect the battery negative terminal.
2. Recover the refrigerant (see page 22-25).
3. Disconnect the condenser fan 2P connector.
4. Loosen the lower mounting bolt, and remove the two upper mounting bolts and condenser fan shroud.

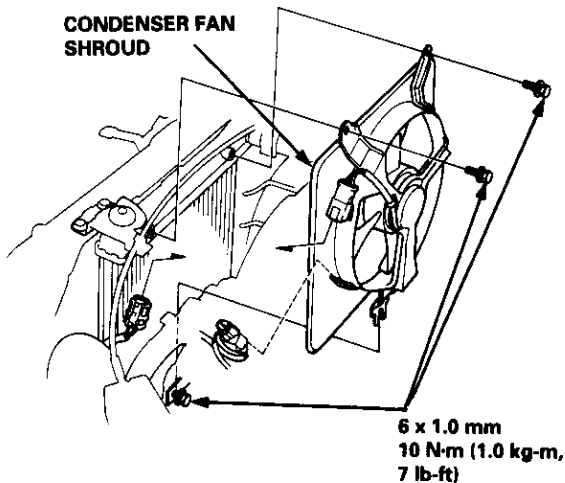

5. Remove the bolt and nut, and disconnect the suction line and discharge line from the compressor.

CAUTION: Cap the open fittings immediately to keep moisture out of the system.

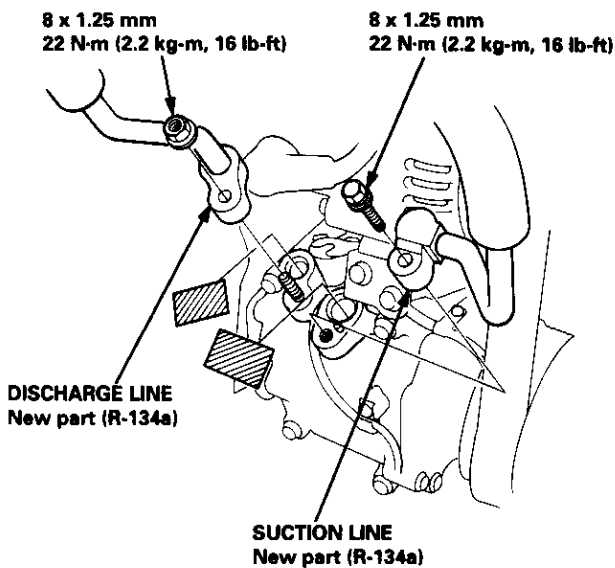

6. Remove the power steering pump belt (see section 17).
7. Loosen the through bolt and adjustment locknut, then turn the adjusting bolt and remove the belt.

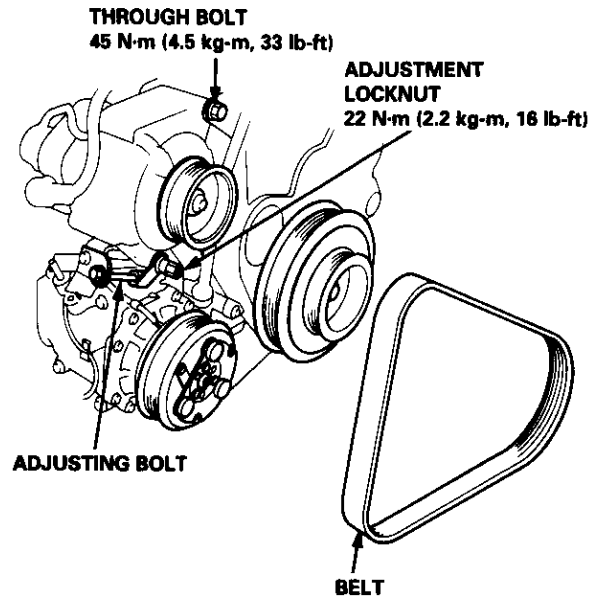

8. Disconnect the compressor clutch 1P connector.
9. Remove the four mounting bolts and compressor.

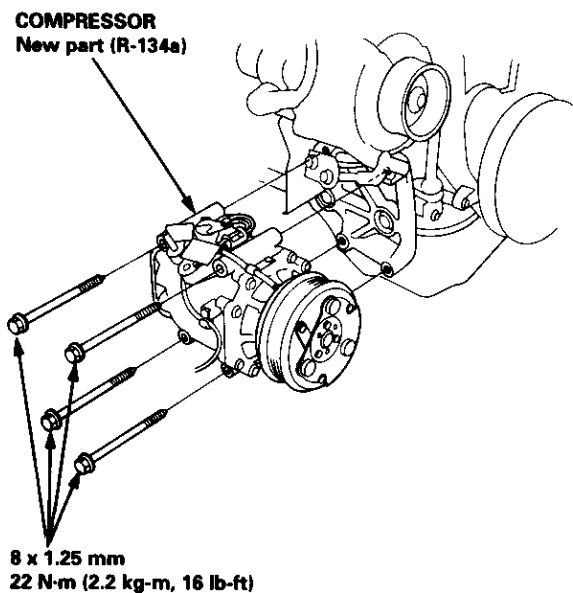



10. If necessary, remove the two mounting bolts and the heat insulator.

6 x 1.0 mm
10 N-m (1.0 kg-m, 7 lb-ft)

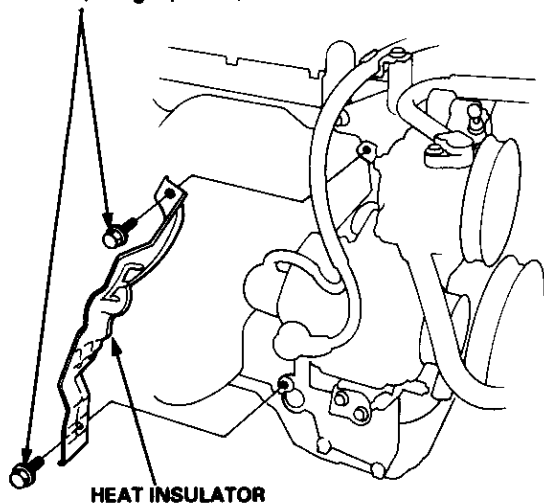

11. If necessary, remove the two mounting bolts and nuts, then remove the compressor bracket.

COMPRESSOR
BRACKET

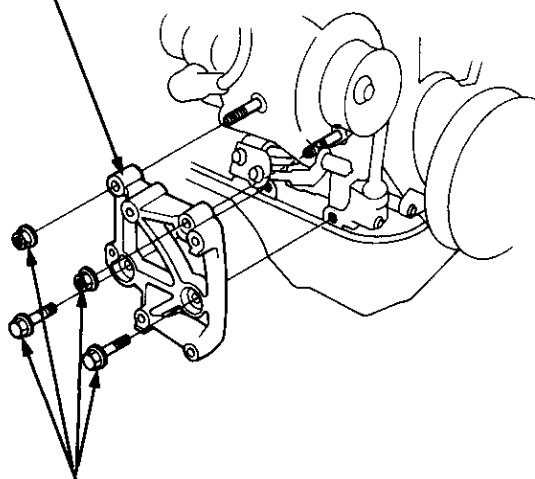

10 x 1.25 mm
50 N-m (5.0 kg-m, 36 lb-ft)

12. Install in the reverse order of removal, and:

- If you're installing a new compressor, drain all the refrigerant oil out of the old compressor and measure its volume. Subtract the volume of old oil from 120 cc (4 fl oz); the result is the amount of oil you should drain from the new compressor (through the suction fitting).
- Replace O-rings with new ones at each fitting, and apply a thin coat refrigerant oil before installing them.

NOTE: Be sure to use the right O-rings for R-134a to avoid leakage.

- Use (SP-10: P/N 38899-P13-003) oil for R-134a Sanden spiral type compressors only.
- Do not return the oil to the container once dispensed and never mix with other refrigerant oils to avoid contamination.
- Immediately after using the oil, replace the cap on the container and seal it to avoid moisture absorption.
- Do not spill the refrigerant oil on the car; it may damage the paint; if the refrigerant oil contacts the paint, wash it off immediately.
- Do not damage the condenser fins when removing/installing the compressor.
- Adjust compressor belt tension (see page 22-40).
- Adjust the power steering pump belt (see section 17).
- Charge the system (see page 22-43).
- Test the system performance (see page 22-26).

Compressor

Clutch Inspection

- Check the rotor pulley bearing play and drag by rotating the rotor pulley by hand. Replace the clutch set with a new one if it is noisy or has excessive play/drag.

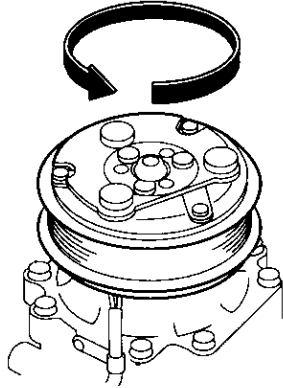

- Turn the rotor pulley by hand and measure the clearance between the rotor pulley and armature plate all the way around. If the clearance is not within specified limits, the armature plate must be removed and shims added or removed as required.

CLEARANCE: 0.35 — 0.65 mm (0.014 — 0.026 in)

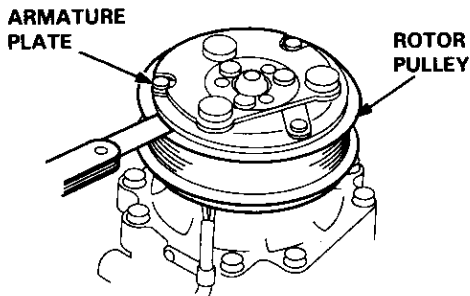

NOTE: The shims are available in four sizes: 0.1 mm, 0.2 mm, 0.4 mm, and 0.5 mm of thickness.

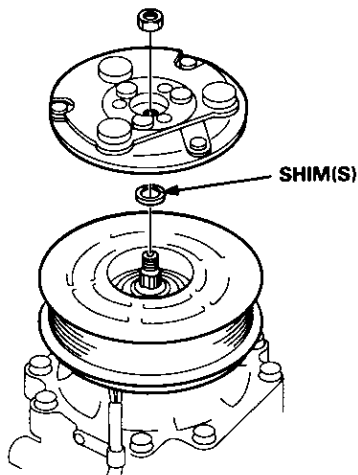

- Release the compressor clutch connector from the connector holder.

Check the thermal protector for continuity.

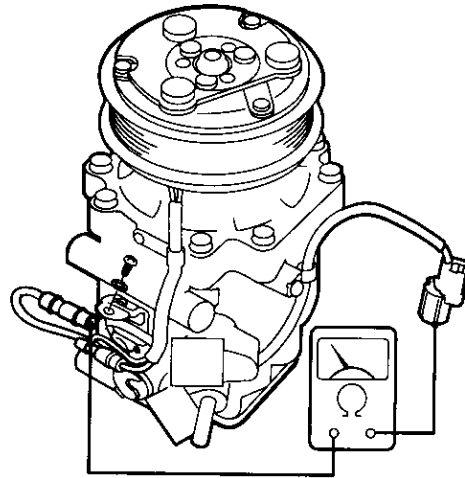

Check the field coil for resistance.

Field Coil Resistance:
 3.2 ± 0.15 ohm at 68°F (20°C)

If resistance is not within specifications, replace the field coil.

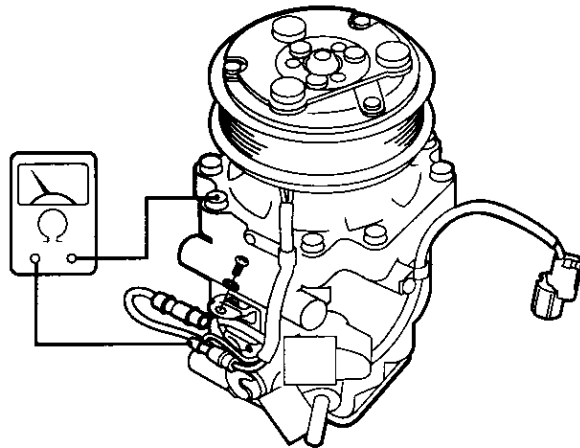



Clutch Overhaul

1. Remove the center nut while holding the armature plate.

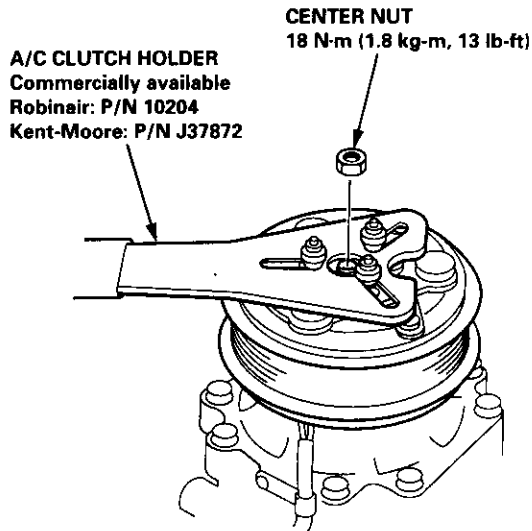

2. Remove the armature plate by pulling it up by hand. If you can not remove it by hand, attach the flywheel puller to the armature plate, screw the bolt in the center and remove the armature plate.

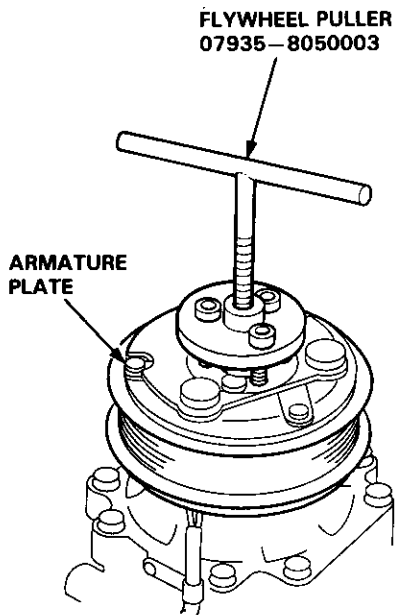

3. Remove the snap ring B with a snap ring pliers.

NOTE:

- Once the snap ring B is removed, replace it with a new one.
- Be careful not to damage the compressor body and rotor pulley during removal/installation.

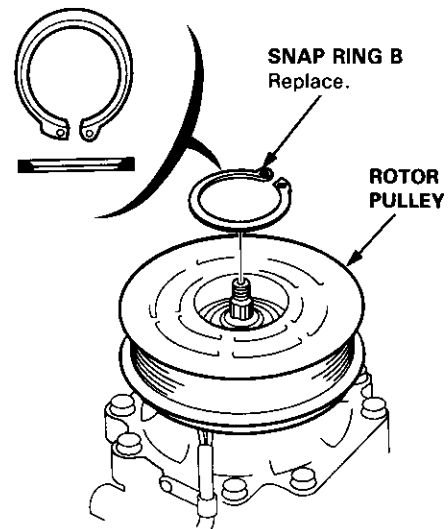

4. Remove the rotor pulley from the shaft with a puller and the special tool.

NOTE: Put the claws of the puller on the back of the rotor pulley, not on the belt area; otherwise the rotor pulley can be damaged.

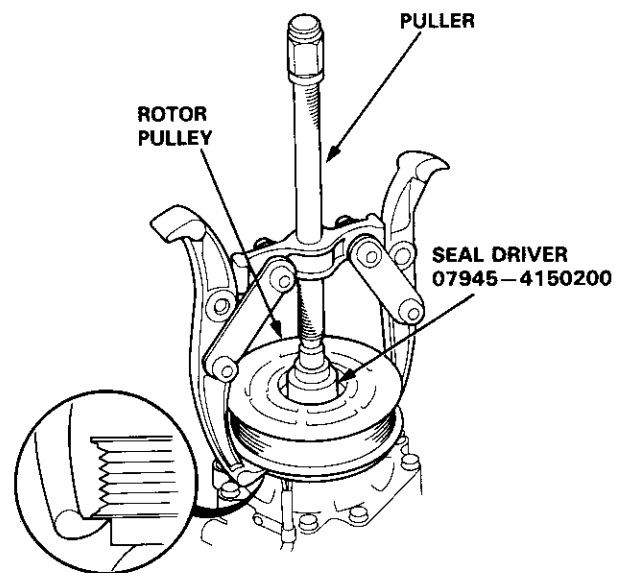

(cont'd)

Compressor

Clutch Overhaul (cont'd)

5. Remove the snap ring A with a snap ring pliers. Release the field coil connector from the connector holder, and disconnect the connector and field coil ground terminal. Remove the field coil from the compressor.

NOTE:

- Once the snap ring A is removed, replace it with a new one.
- When installing the field coil, align the boss on the field coil with the hole in the compressor.

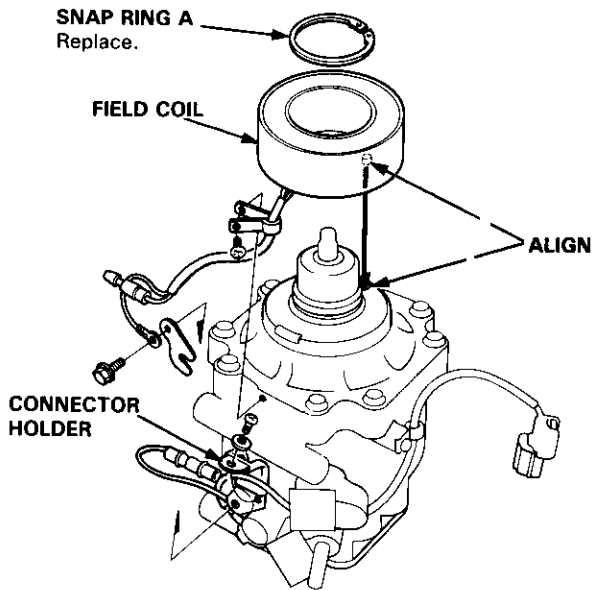

6. Position the rotor pulley squarely over the field coil. Press the rotor pulley onto the compressor boss with the special tool. If the rotor pulley does not press on straight, remove it and check the rotor pulley and compressor boss for burrs or damage.

CAUTION: Maximum press load: 400 kg (882 lbs)

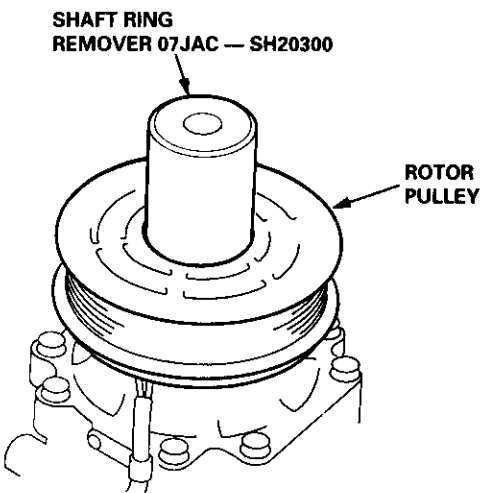

7. Install in the reverse order of removal, and:
 - Clean the rotor pulley and compressor sliding surfaces with non-petroleum solvent.
 - Install the snap rings with the chamfered side facing out and make sure the snap rings are in the groove completely.
 - After installing, make sure that the rotor pulley turns smoothly.
 - Route and clamp the wires properly or they can be damaged by the rotor pulley.



Thermal Protector Replacement

1. Remove the bolt, field coil terminal, and retainer.
2. Remove the thermal protector.
Remove the residue of silicone sealant from the top of thermal protector.

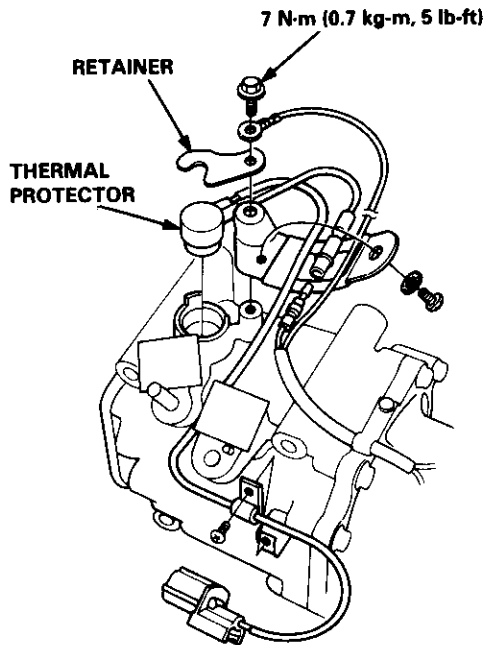

3. Apply silicone sealant to the top of the thermal protector.

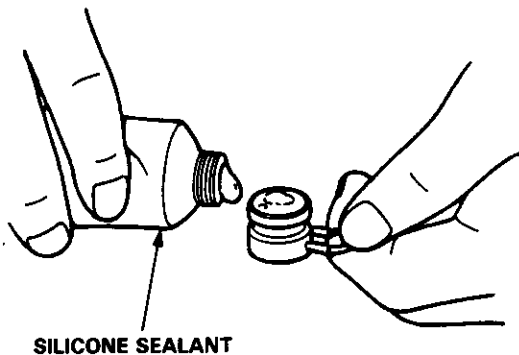

4. Install in the reverse order of removal.

Relief Valve Replacement

Removal

NOTE: Make sure the suction and discharge ports are plugged with caps.

1. Remove the three bolts, heat insulator, relief valve, and O-ring.

NOTE: Be sure to use the right O-rings for R-134a to avoid leakage.

CAUTION: Be careful not to spill compressor oil, and make sure there is no foreign matter in the system.

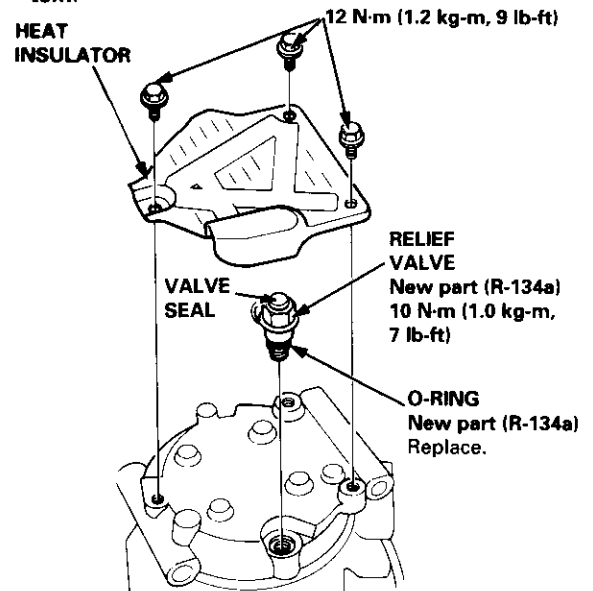

Installation

1. Clean off the relief valve mating surface.
2. Replace O-ring with new one at the relief valve, and apply a thin coat of refrigerant oil (SP-10: P/N 38899-P13-003) before installing it.

NOTE:

- Do not return the oil to the container once dispensed and never mix with other refrigerant oils to avoid contamination.
- Immediately after using the oil, replace the cap on the container and seal it to avoid moisture absorption.
- Do not spill the refrigerant oil on the car; it may damage the paint; if the refrigerant oil contacts the paint, wash it off immediately.

3. Tighten the relief valve.
4. Check the relief valve for leaks and cap the relief valve with the valve seal.

Belt Adjustment

1. Apply a force of 100 N (10 kg, 22 lbs) and measure the deflection between the alternator and crankshaft pulley.

Compressor Belt

Deflection:

Used Belt: 10.0 — 12.0 mm (0.39 — 0.47 in)

New Belt: 4.5 — 7.0 mm (0.18 — 0.28 in)

P/S Pump Belt

Used Belt: 13.5 — 16.5 mm (0.53 — 0.65 in)

New Belt: 9.5 — 11.5 mm (0.37 — 0.45 in)

NOTE:

- If there are cracks or any damage evident on the belt, replace it with a new one.
- "Used belt" means a belt which has been used for five minutes or more.
- "New belt" means a belt which has been used for less than five minutes.

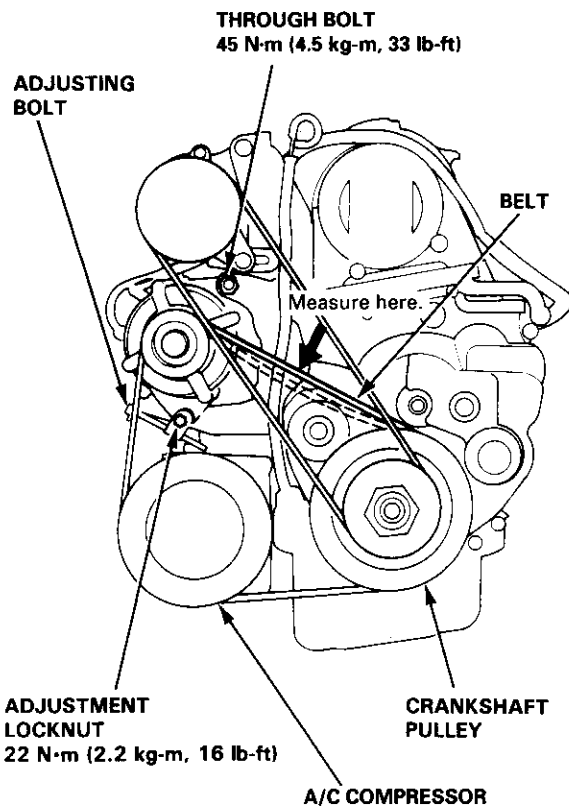

Measure with Belt Tension Gauge:

Attach the belt tension gauge to the belt and measure the tension of the belt.

Compressor Belt

Tension:

Used Belt: 450 — 600 N (45 — 60 kg, 99 — 132 lbs)

New Belt: 950 — 1150 N

(95 — 115 kg, 209 — 254 lbs)

P/S Belt

Used Belt: 350 — 500 N (35 — 50 kg, 77 — 110 lbs)

New Belt: 700 — 900 N (70 — 90 kg, 154 — 198 lbs)

NOTE:

- If there are cracks or any damage evident on the belt, replace it with a new one.
- See the instructions for the tension gauge.

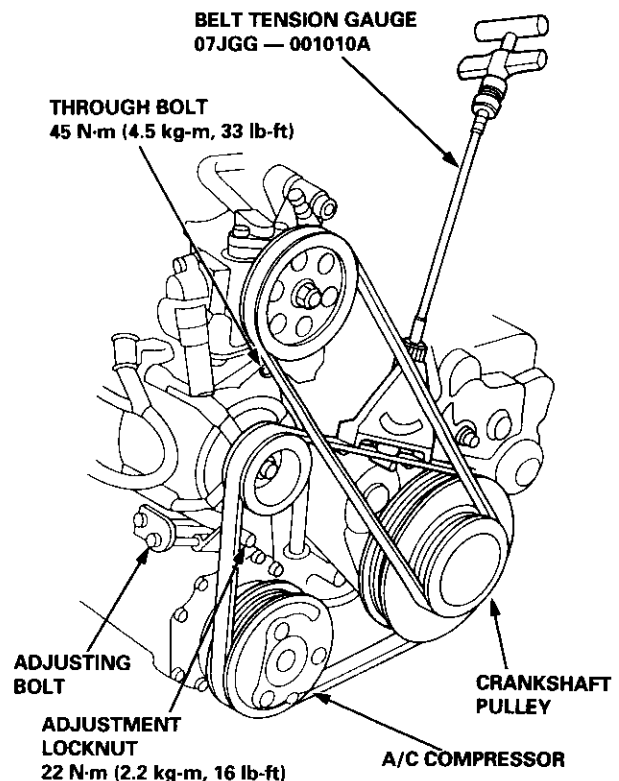

2. Loosen the through bolt and alternator nut.
3. Turn the adjusting bolt to obtain the proper belt tension, then retighten the adjustment locknut and through bolt.
4. Recheck the deflection of the belt.

Condenser

Replacement

1. Recover the refrigerant (see page 22-25).
2. Disconnect the A/C pressure switch 2P connector, then remove the receiver line A.
3. Disconnect the discharge line from the condenser.

CAUTION: Cap the open fittings immediately to keep moisture and dirt out of the system.

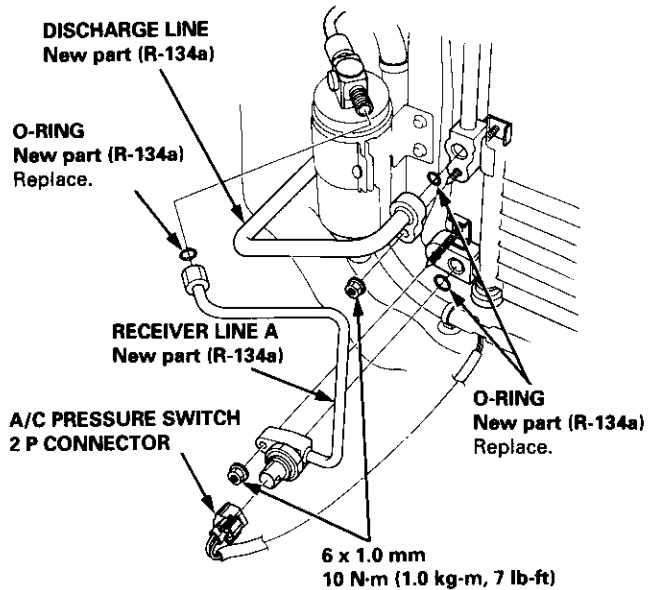

4. Remove the two bolts and A/C hose bracket.
5. Remove the four bolts and radiator upper mount brackets.

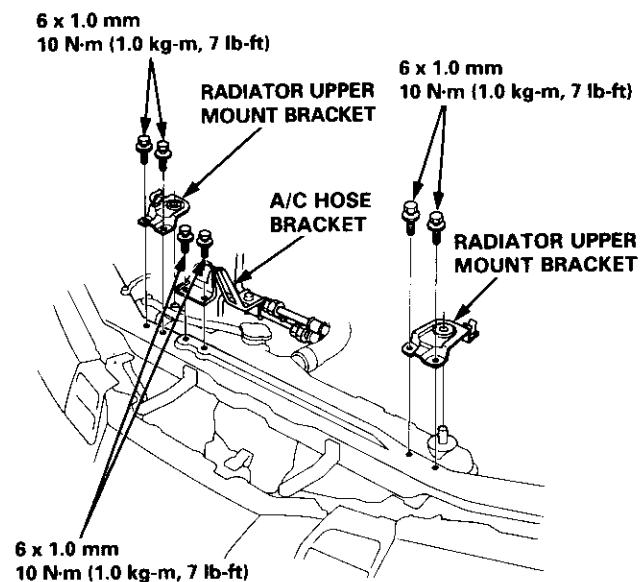

6. Remove the two mounting bolts, then lift out the condenser as shown.

CAUTION: Do not damage the radiator and condenser fins when removing the condenser.

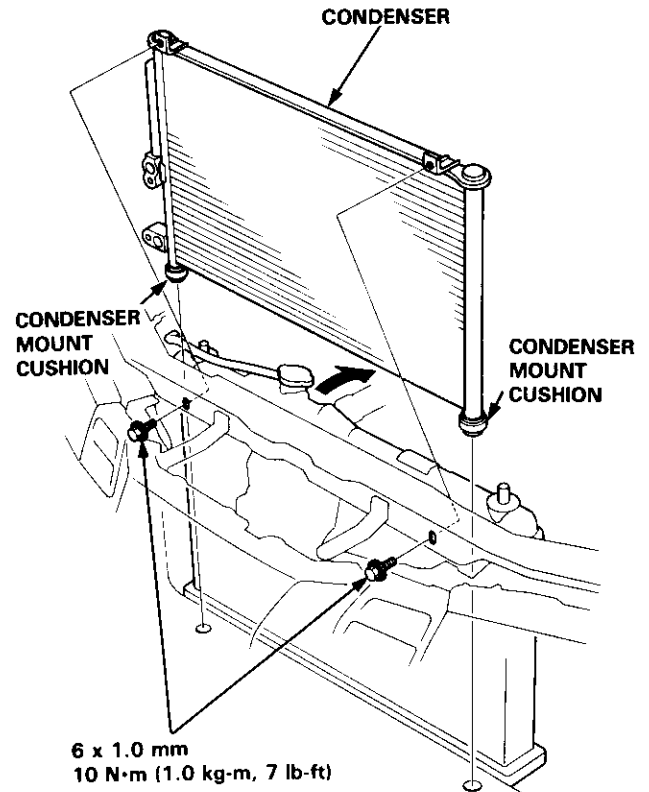

7. Install in the reverse order of removal, and:
 - If you're installing a new condenser, add refrigerant oil (SP-10: P/N 38899-P13-003) (see page 22-24).
 - Replace O-rings with new ones at each fitting, and apply a thin coat of refrigerant oil (SP-10: P/N 38899-P13-003) before installing them.

NOTE: Be sure to use the right O-rings for R-134a to avoid leakage.

- Be sure to install the condenser mount cushions securely into the holes.
- Charge the system (see page 22-43) and test its performance (see page 22-26).

A/C System Service

Evacuation

Only use service equipment that is U.L.-listed and is certified to meet the requirements of SAE J2210 to remove R-134a from the air conditioner system.

CAUTION: Exposure to air conditioner refrigerant and lubricant vapor or mist can irritate eyes, nose and throat. Avoid breathing the air conditioner refrigerant and lubricant vapor or mist.

If accidental system discharge occurs, ventilate work area before resuming service.

R-134a service equipment or vehicle air conditioner systems should not be pressure tested or leak tested with compressed air.

⚠ WARNING Some mixture of air and R-134a have been shown to be combustible at elevated pressures and can result in fire or explosion causing injury or property damage. Never use compressed air to pressure test R-134a service equipment or vehicle air conditioner systems.

Additional health and safety information may be obtained from the refrigerant and lubricant manufacturers.

1. When an A/C System has been opened to the atmosphere, such as during installation or repair, it must be evacuated using a R-134a refrigerant Recovery/Recycling/Charging System. (If the system has been open for several days, the receiver/dryer should be replaced.)
2. Connect a R-134a refrigerant Recovery/Recycling/Charging System to the car as shown following the equipment manufacturer's instructions.

NOTE: If low pressure does not reach more than 700 mm Hg (27 in-Hg) in 15 minutes, there is probably a leak in the system. Partially charge the system and check for leaks (see Leak Test).

Recovery/Recycling/Charging System

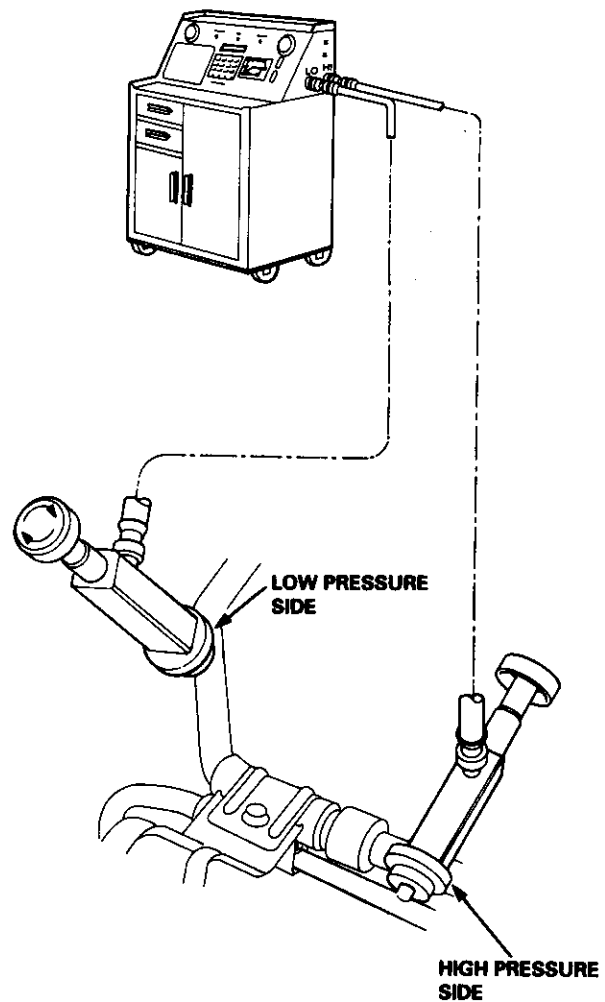



Charging

Only use service equipment that is U.L.-listed and is certified to meet the requirements of SAE J2210 to remove R-134a from the air conditioner system.

CAUTION: Exposure to air conditioner refrigerant and lubricant vapor or mist can irritate eyes, nose and throat. Avoid breathing the air conditioner refrigerant and lubricant vapor or mist.

If accidental system discharge occurs, ventilate work area before resuming service. Additional health and safety information may be obtained from the refrigerant and lubricant manufacturers.

Refrigerant capacity: 650±g (23±oz)

CAUTION: Do not overcharge the system; the compressor will be damaged.

Connect a R-134a refrigerant Recovery/Recycling/Charging System to the car as shown following the equipment manufacturer's instructions.

Recovery/Recycling/Charging System

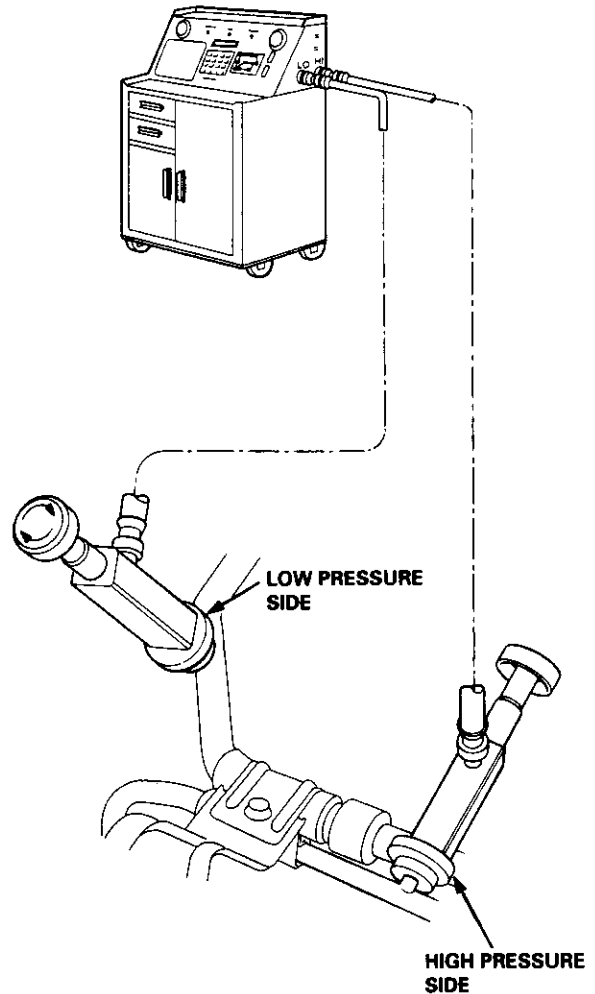

A/C System Service

Leak Test

Only use service equipment that is U.L.-listed and is certified to meet the requirements of SAE J2210 to remove R-134a from the air conditioner system.

CAUTION: Exposure to air conditioner refrigerant and lubricant vapor or mist can irritate eyes, nose and throat. Avoid breathing the air conditioner refrigerant and lubricant vapor or mist.

If accidental system discharge occurs, ventilate work area before resuming service.

R-134a service equipment or vehicle air conditioner systems should not be pressure tested or leak tested with compressed air.

WARNING Some mixture of air and R-134a have been shown to be combustible at elevated pressures and can result in fire or explosion causing injury or property damage. Never use compressed air to pressure test R-134a service equipment or vehicle air conditioner systems.

Additional health and safety information may be obtained from the refrigerant and lubricant manufacturers.

1. Connect a R-134a refrigerant Recovery/Recycling/Charging System to the car as shown following the equipment manufacturer's instructions.

NOTE: Be sure to install the same amount of new refrigerant oil back into the A/C system before charging.

2. Open high pressure valve to charge the system to about 100 kPa (1.0 kg/cm², 14 psi), then close the supply valve.
3. Check the system for leaks using a R-134a refrigerant leak detector with an accuracy of 0.5/oz. per year or better.
4. If you find leaks that require the system to be opened (to repair or replace hoses, fittings, etc.), recover the system according to the Recover Procedure on page 22-25.
5. After checking and repairing leaks, the system must be evacuated (see System Evacuation on page 22-42).

Recovery/Recycling/Charging System

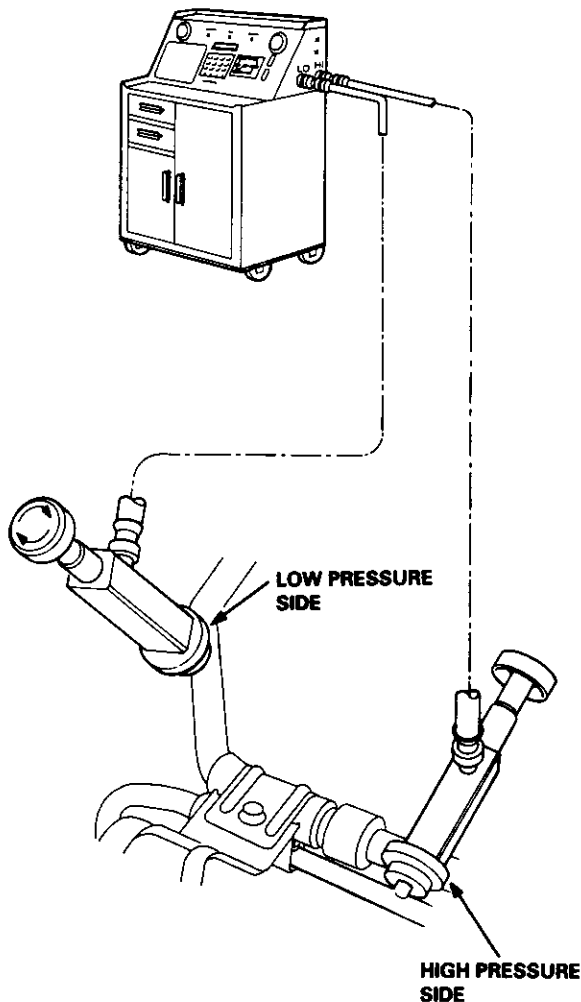

Electrical

Special Tools	23-2	Lights, Exterior	
Troubleshooting		Back-up Lights	23-192
Tips and Precautions	23-3	Brake/High Mount Brake Lights	23-194
Five-step Troubleshooting	23-5	Headlights	23-183
How to Use This Section		License Plate Lights	23-188
Schematic Symbols	23-6	Parking Lights	23-186
Wire Color Codes	23-6	Side Marker Lights	23-185,188
Relay and Control Unit Locations		Taillights	23-187
Engine Compartment	23-7	Turn Signal Lights	23-185
Dashboard	23-8	Lights, Interior	
Dashboard/Seat	23-11	Ceiling Light	23-190
Floor	23-12	*Dash Lights Brightness Control	23-201
Index to Circuits and Systems		Entry Light	23-173
Airbag	23-287	Ignition Key Light	23-173
Air Conditioner	Section 22	Trunk Light	23-189
Anti-lock Brake System (ABS)	Section 19	*Lighting System	23-174
Automatic Transmission System	Section 14	PGM-FI System	Section 11
Battery	23-66	Power Antenna	23-213
Blower Controls	Section 21	Power Distribution	23-51
Charging System	23-102	*Power Door Locks	23-255
*Cigarette Lighter	23-224	*Power Mirrors	23-242
*Clock	23-218	Power Windows	23-248
Control Unit Locations	23-7	Radiator and Condenser Fan Controls	23-115
*Cruise Control	23-272	*Rear Window Defogger	23-227
Daytime Running Lights (Canada)	23-180	Relay Locations	23-7
Fuel Pump	Section 11	Seat Heaters (Canada)	23-232
Fuses		*Side Marker/Turn Signal/Hazard Flasher System	23-196
Under-dash Fuse/Relay Box	23-48	Spark Plugs	23-101
Under-hood Fuse/Relay Box	23-46	Starting System	23-76
*Gauges		*Stereo Sound System	23-206
Circuit Diagram	23-126	*Sunroof	23-237
Engine Coolant Temperature (ECT) Gauge	23-123	Supplemental Restraint System (SRS)	23-287
Fuel Gauge	23-123	Vehicle Speed Sensor (VSS)	23-138
Speedometer	23-124	Wiper/Washer	23-263
Tachometer	23-124	Wires, Harness, and Connectors	
Ground		Connector Identifications and Wire Harness Routing	23-13
Distribution	23-59	Wiring Diagram	23-332
Locations	23-13		
Heater Controls	Section 21		
*Horns	23-220		
*Ignition Switch	23-73		
*Ignition System	23-90		
Ignition Timing Control	23-93		
Indicators			
*A/T Gear Position Indicator	23-144		
High Beam Indicator	23-132		
*Safety Indicator	23-151		
Turn Signal Indicator	23-132		
*Integrated Control Unit	23-164		
*Interlock System	23-158		

*Read SRS precautions on page 23-294, then install the short connector on the airbag before working in these areas.



Special Tools

Ref. No.	Tool Number	Description	Qty	Page Reference
①	KS-AHM-32-003	Digital Multimeter	1	23-99, 293
②	07JGG-001010A	Belt Tension Gauge	1	23-113, 114
③	07JAA-001000B	Antenna Wrench	1	23-214
④*	07HAZ-SG00400	Deployment Tool	1	23-322
⑤**	07MAZ-SL00500	Test Harness A	1	23-303
⑥**	07MAZ-SPO0500	Test Harness B	1	23-306
⑦*	07LAZ-SL40300	Test Harness C	1	23-222, 278, 307
⑧*	07LAZ-SL40400	Test Harness D	1	23-309
⑨	A973X-041-XXXXX	Vacuum Pump Gauge	1	23-283

*: Included in SRS Tool Set 07MAZ-SM5000A

** : Included in SRS Tool Set 07MAZ-SL0010A

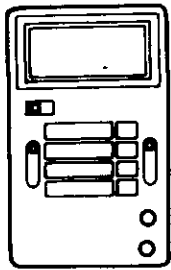

①



②

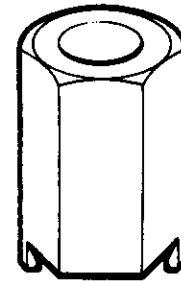

③

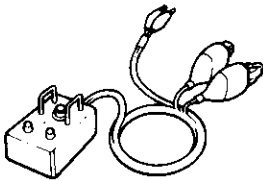

④

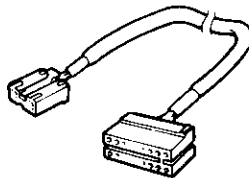

⑤

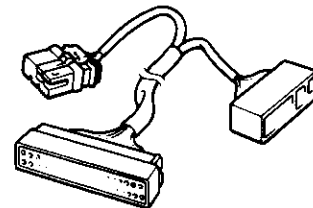

⑥

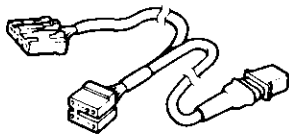

⑦

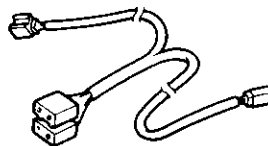

⑧

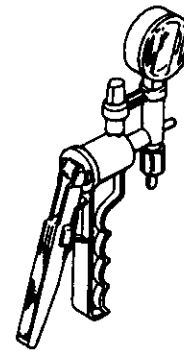

⑨

Troubleshooting



Tips and Precautions

Before Troubleshooting

- Check applicable fuses in the appropriate fuse/relay box.
- Check the battery for damage, state of charge, and clean and tight connections.
- Check the alternator belt tension.

CAUTION:

- Do not quick-charge a battery unless the battery ground cable has been disconnected. Otherwise you will damage the alternator diodes.
- Do not attempt to crank the engine with the battery ground cable loosely connected or you will severely damage the wiring.

Handling Connectors

- Make sure the connectors are clean and have no loose wire terminals.
- Make sure multiple cavity connectors are packed with grease (except watertight connectors).
- All connectors have push-down release type locks.

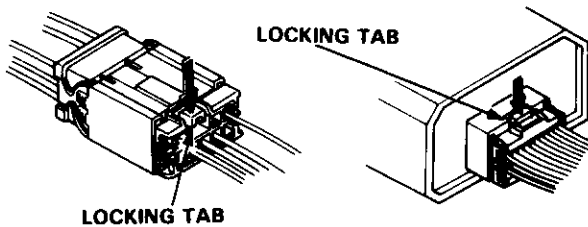

- Some connectors have a clip on their side used to attach them to a bracket on the body or on another component. This clip has a pull type lock.
- Some mounted connectors cannot be disconnected unless you first release the lock and remove the connector from its bracket.

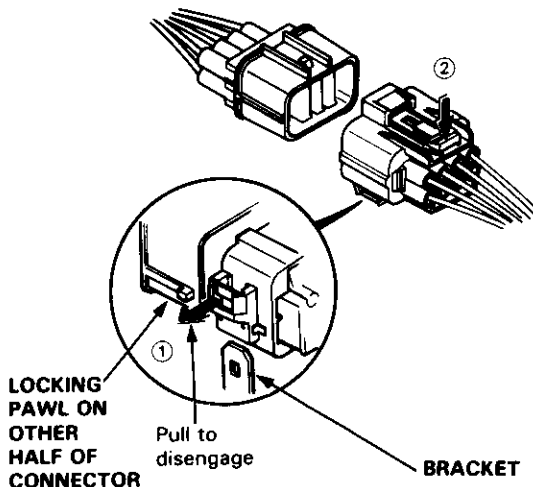

- Never try to disconnect connectors by pulling on their wires; pull on the connector halves instead.
- Always reinstall plastic covers.

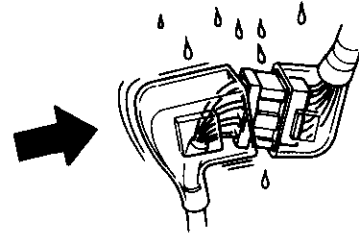

- Before connecting connectors, make sure the terminals are in place and not bent.

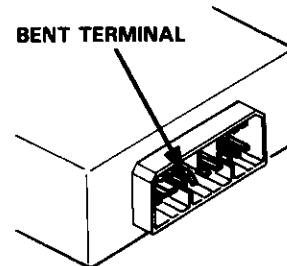

- Check for loose retainer and rubber seals.

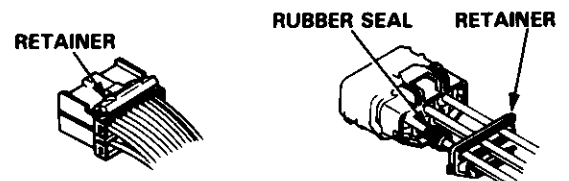

- The backs of some connectors are packed with grease. Add grease if necessary. If the grease is contaminated, replace it.

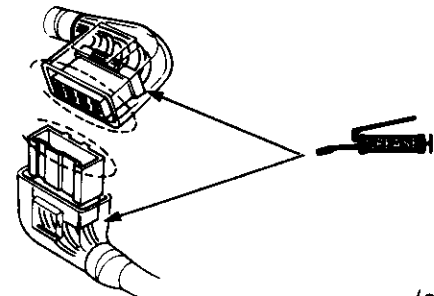

(cont'd)

Troubleshooting

Tips and Precautions (cont'd)

- Insert the connector all the way and make sure it is securely locked.
- Position wires so that the open end of the cover faces down.

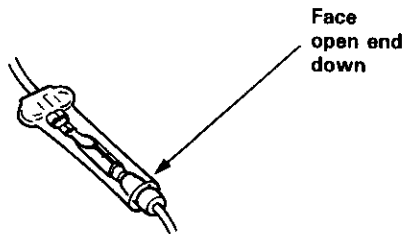

Handling Wires and Harnesses

- Secure wires and wire harnesses to the frame with their respective wire ties at the designated locations.
- Remove clips carefully; don't damage their locks.

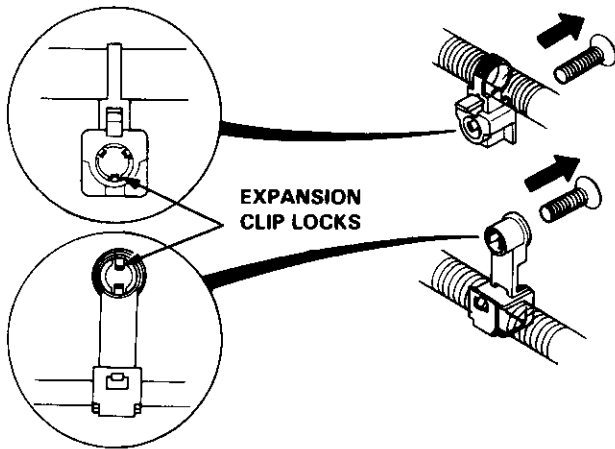

Slip pliers under the clip base and through the hole at an angle, then squeeze the expansion tabs to release the clip.

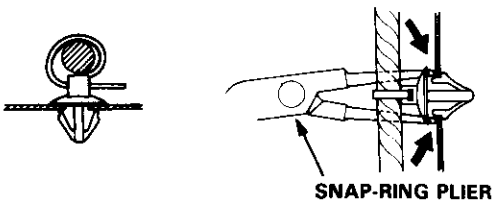

- After installing harness clips, make sure the harness doesn't interfere with any moving parts.
- Keep wire harnesses away from exhaust pipes and other hot parts, from sharp edges of brackets and holes, and from exposed screws and bolts.

- Seat grommets in their grooves properly.

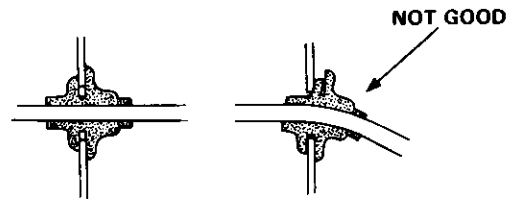

Testing and Repairs

- Do not use wires or harnesses with broken insulation. Replace them or repair them by wrapping the break with electrical tape.
- After installing parts, make sure that no wires are pinched under them.
- When using electrical test equipment, follow the manufacturer's instructions and those described in this manual.
- If possible, insert the probe of the tester from the wire side (except waterproof connector).

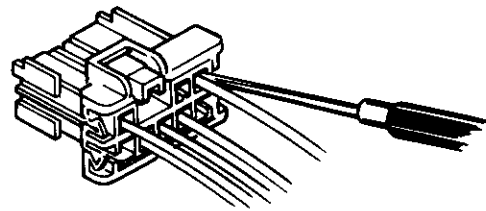

- Use a probe with a tapered tip.

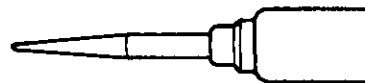

- Refer to the instructions in the Honda Terminal Kit for identification and replacement of connector terminals.



Five-Step Troubleshooting

1. Verify The Complaint

Turn on all the components in the problem circuit to verify the customer complaint. Note the symptoms. Do not begin disassembly or testing until you have narrowed down the problem area.

2. Analyze The Schematic

Look up the schematic for the problem circuit. Determine how the circuit is supposed to work by tracing the current paths from the power feed through the circuit components to ground. If several circuits fail at the same time, the fuse or ground is a likely cause.

Based on the symptoms and your understanding of the circuit operation, identify one or more possible causes of the problem.

3. Isolate The Problem By Testing The Circuit

Make circuit tests to check the diagnosis you made in step 2. Keep in mind that a logical, simple procedure is the key to efficient troubleshooting. Test for the most likely cause of failure first. Try to make tests at points that are easily accessible.

4. Fix The Problem











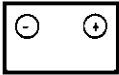







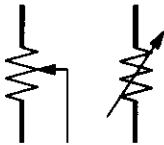

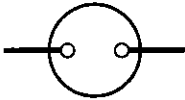





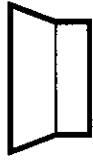

Once the specific problem is identified, make the repair. Be sure to use proper tools and safe procedures.

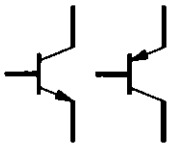
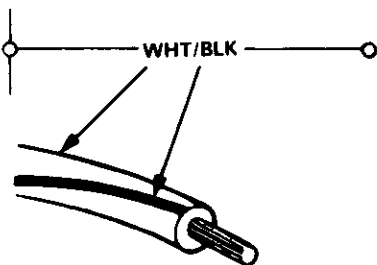
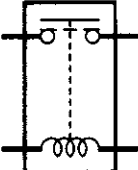
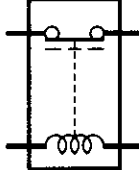
5. Make Sure The Circuit Works

Turn on all components in the repaired circuit in all modes to make sure you've fixed the entire problem. If the problem was a blown fuse, be sure to test all of the circuits on the fuse. Make sure no new problems turn up and the original problem does not recur.

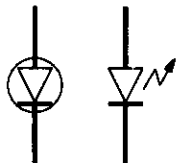
How to Use This Section

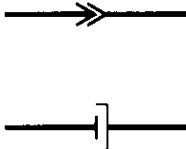
Schematic Symbols

BATTERY  		GROUND Ground terminal  Component ground 		FUSE 	COIL, SOLENOID 	CIGARETTE LIGHTER 
RESISTOR 	VARIABLE RESISTOR 	THERMISTOR 	IGNITION SWITCH 	BULB 	HEATER 	
MOTOR 	PUMP 	CIRCUIT BREAKER 	HORN 	DIODE 	SPEAKER, BUZZER 	
ANTENNA Mast  Window 		TRANSISTOR (Tr) 		Wire Color Codes The following abbreviations are used to identify wire colors in the circuit schematics: WHT White YEL Yellow BLK Black BLU Blue GRN Green RED Red ORN Orange PNK Pink BRN Brown GRY Gray PUR Purple LT BLU Light Blue LT GRN Light Green The wire insulation has one color or one color with another color stripe. The second color is the stripe. 		
RELAY (In normal position) Normally open relay Normally closed relay  		CONDENSER 				
SWITCH (In normal position) Normally open switch  Normally closed switch 		LIGHT EMITTING DIODE (LED) 				
CONNECTION Input  Output 	CONNECTOR 	REED SWITCH 				

Relay and Control Unit Locations



Engine Compartment

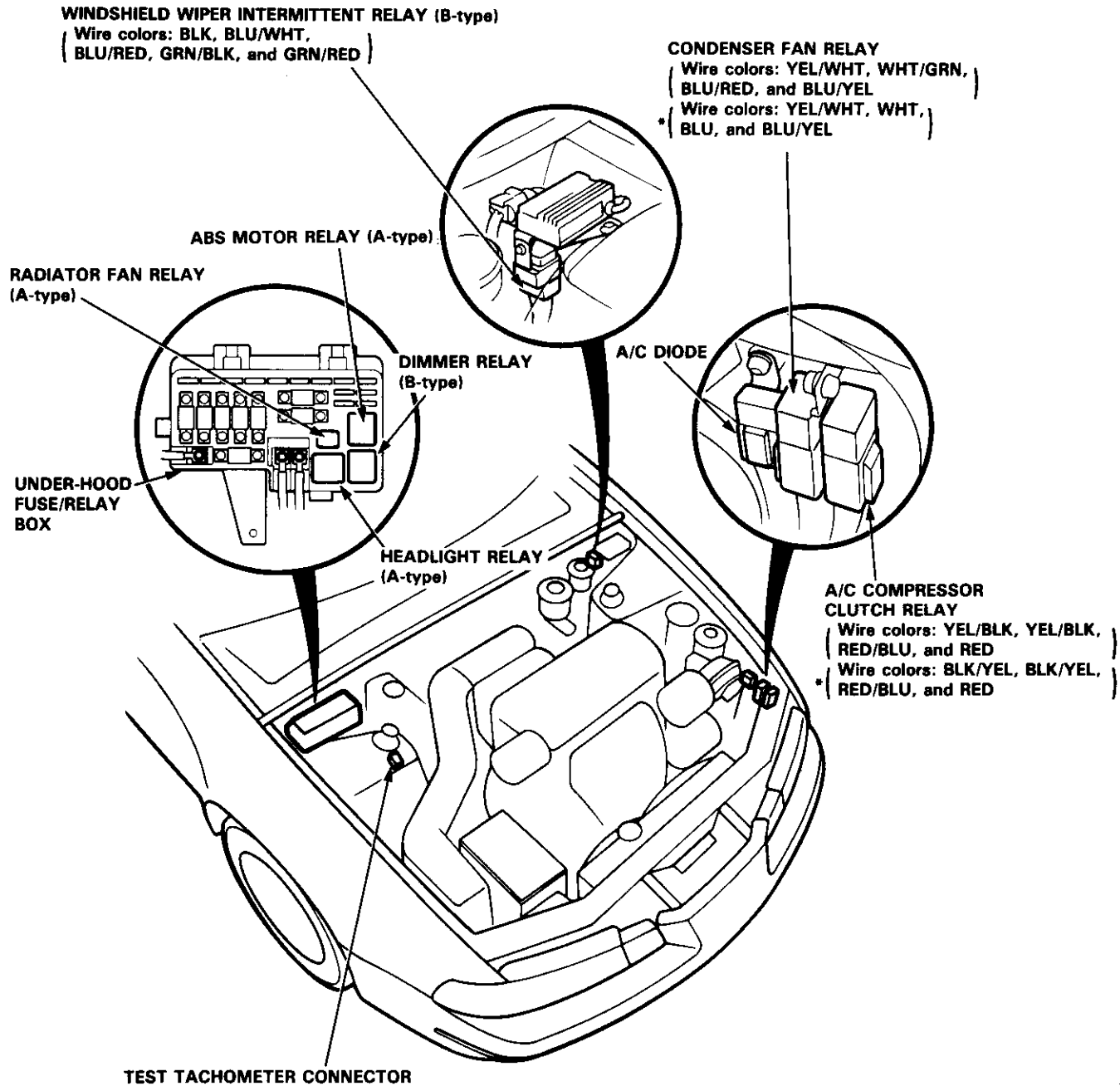

*: With OPTIONAL A/C

Relay and Control Unit Locations

Dashboard

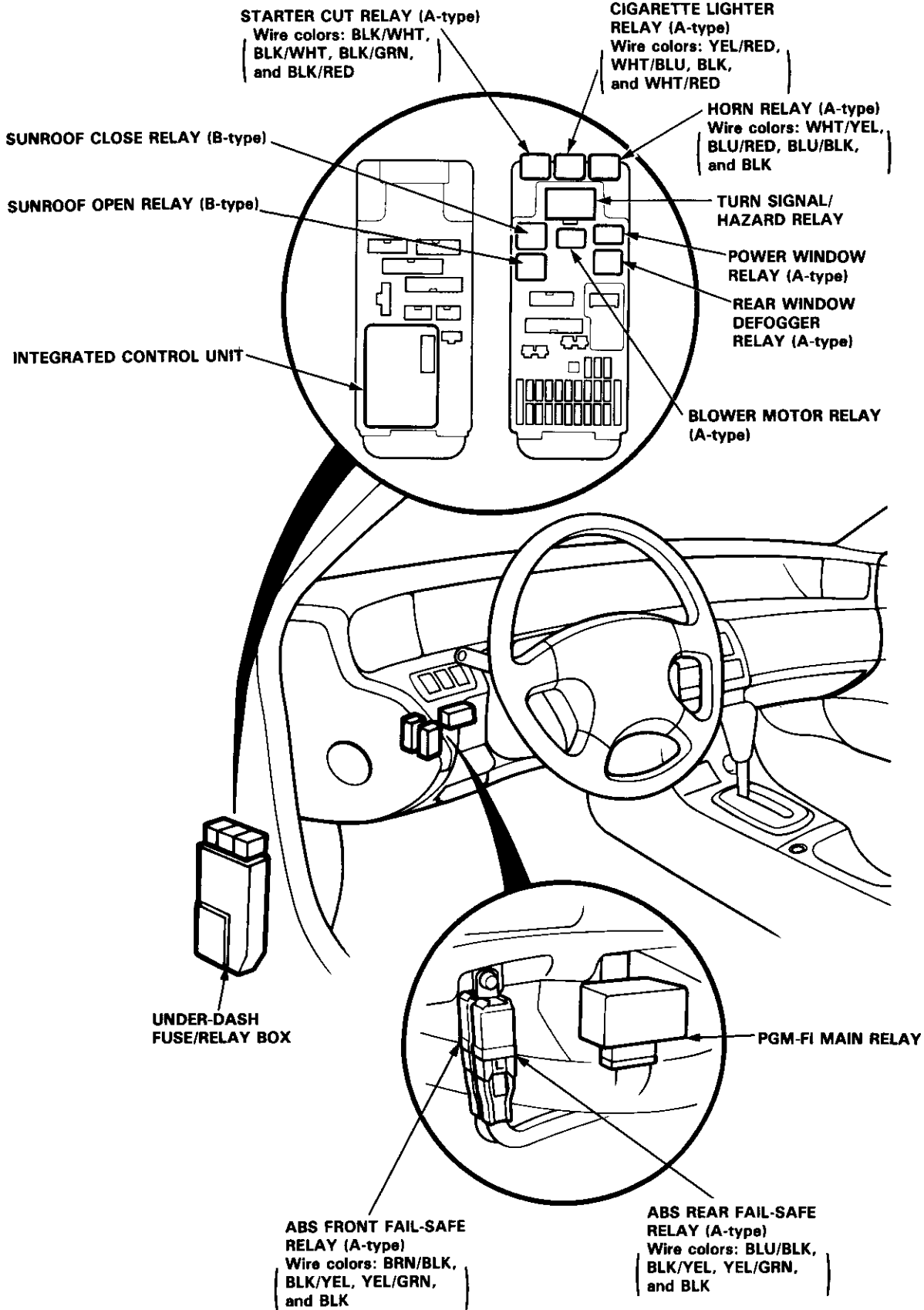

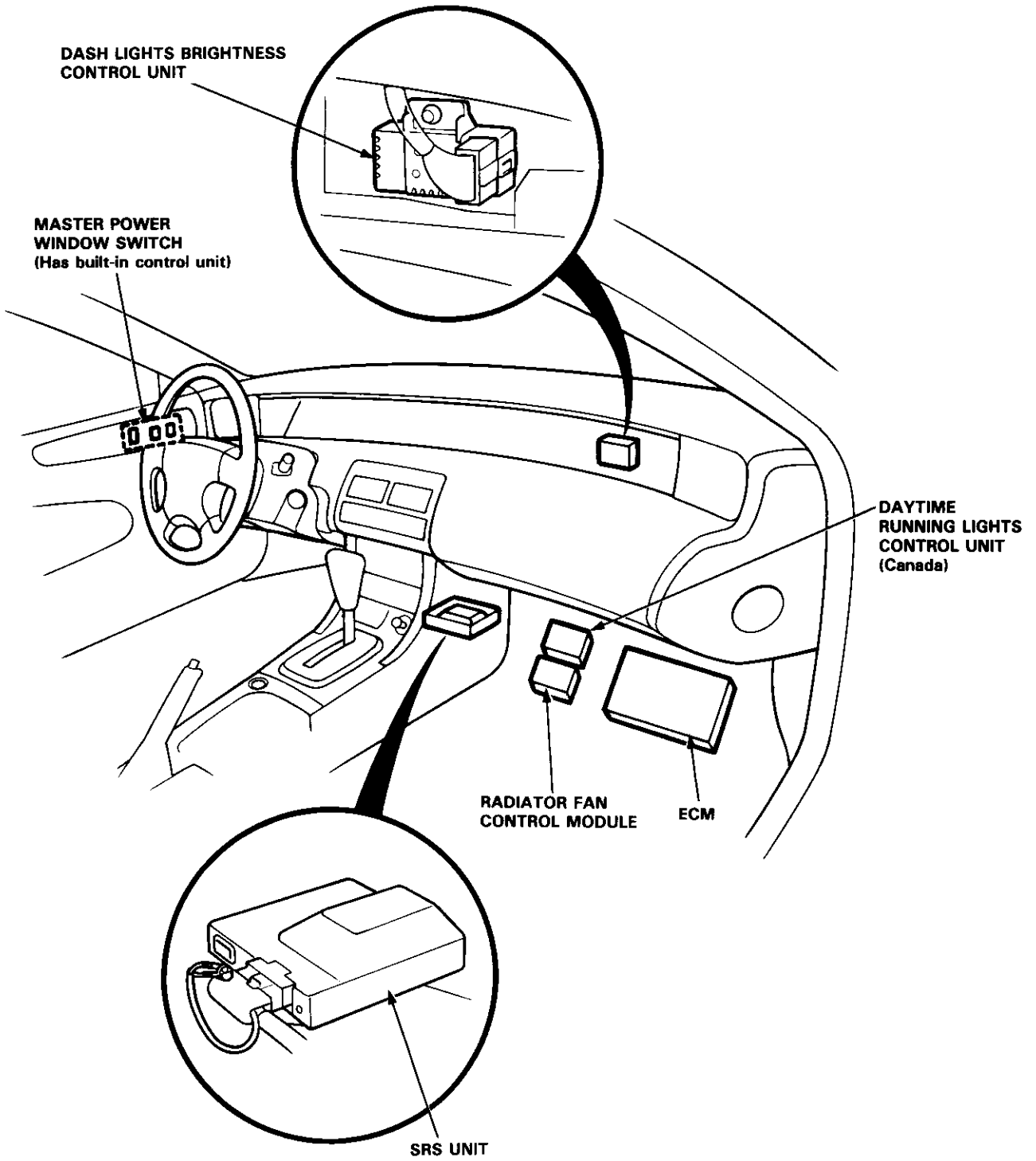

(cont'd)

Relay and Control Unit Locations

Dashboard (cont'd)

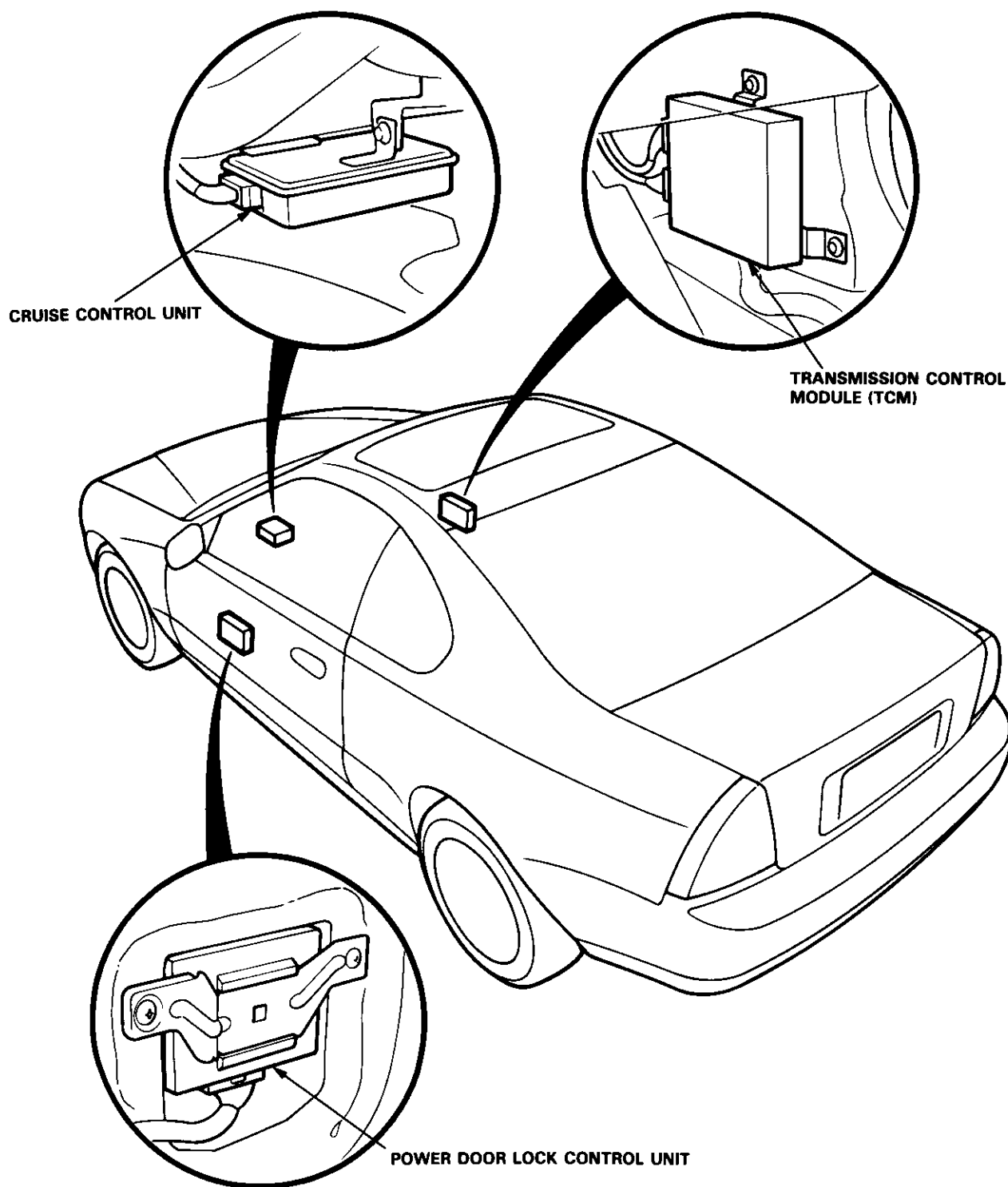



Dashboard/Seat

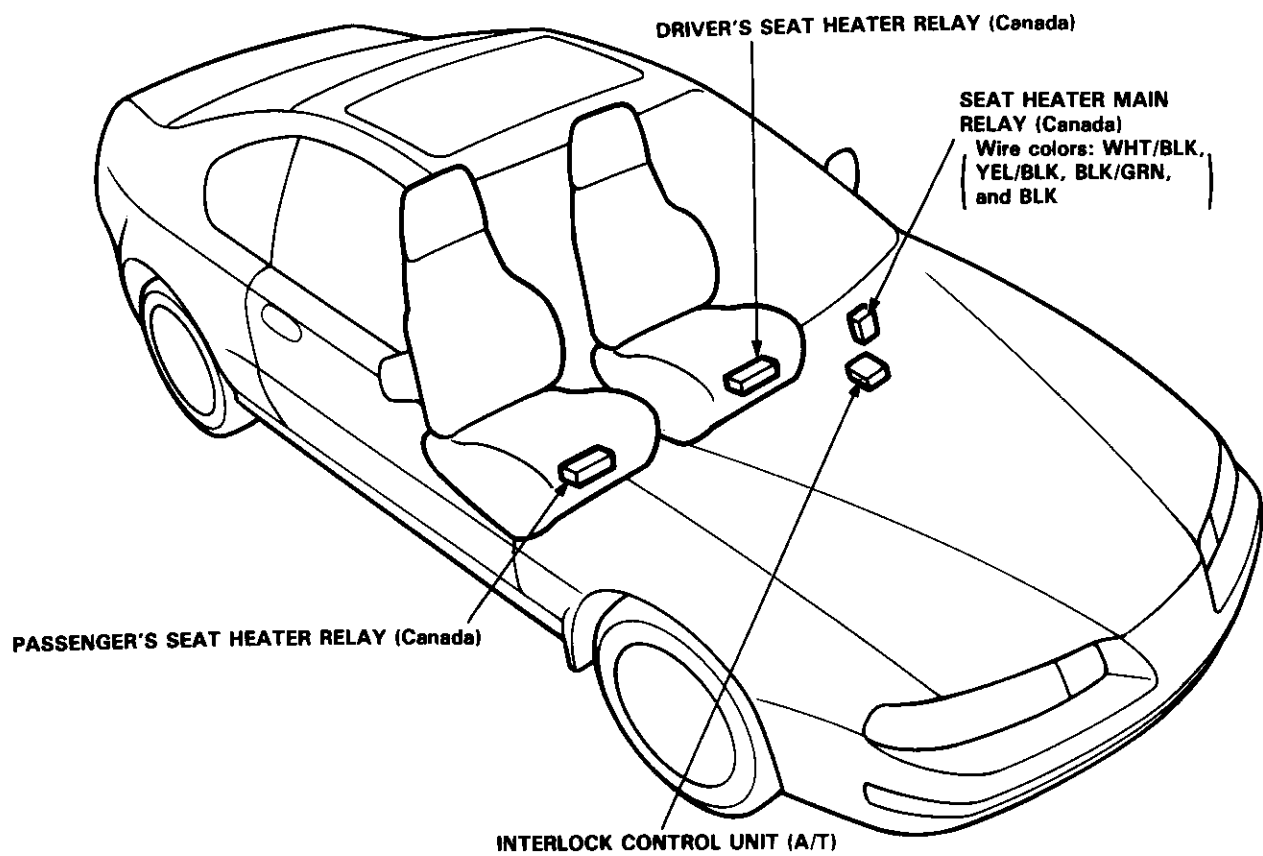

Relay and Control Unit Locations

Floor

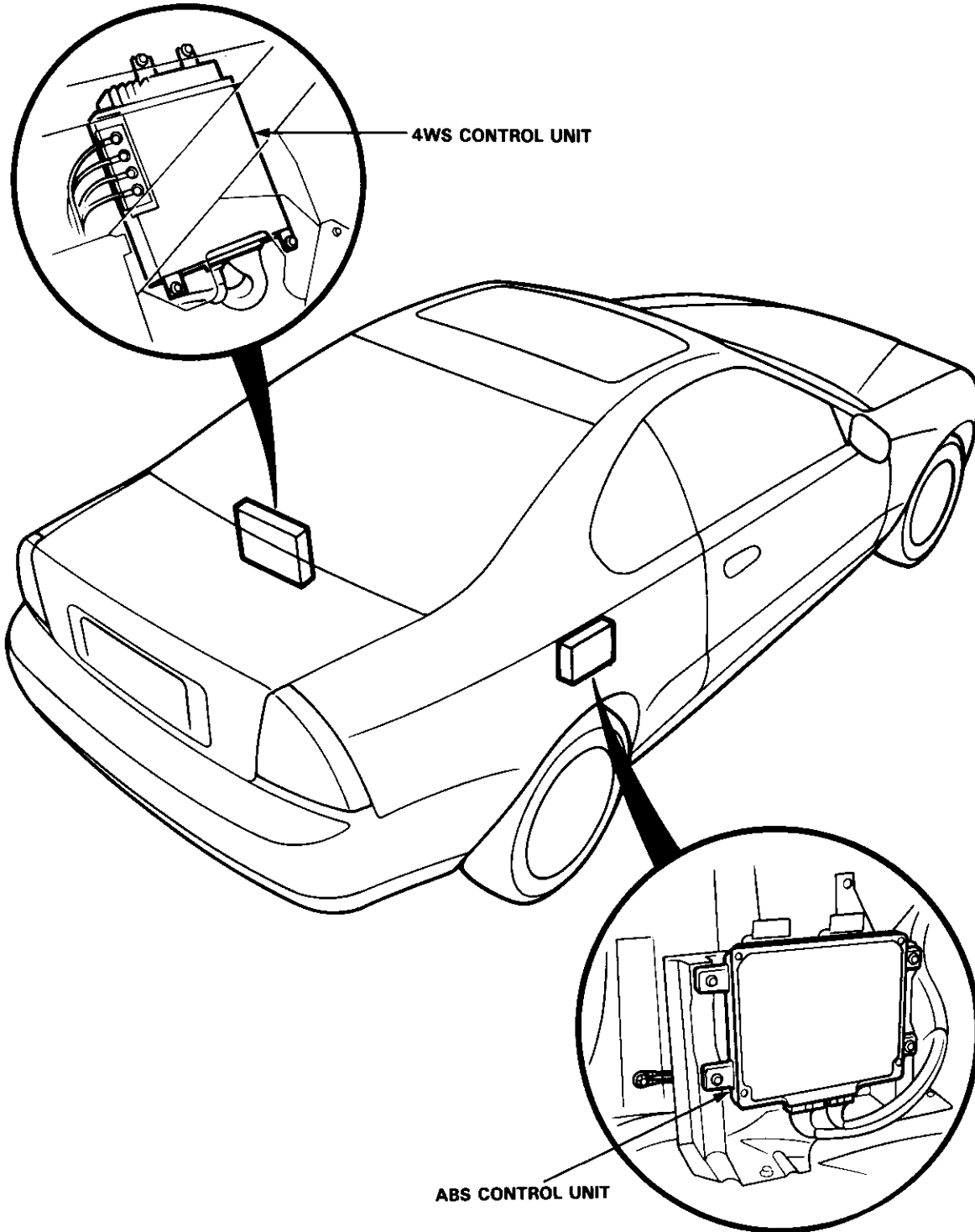

Connector Identification and Wire Harness Routing



How to Identify Connectors:

Identification numbers have been assigned to all connectors. The number is preceded by the letter "C" for connectors, "G" for ground terminals or "T" for non-ground terminals.

Harness	Location	Engine Compartment	Dashboard	Others (Floor, Door, Trunk, and Roof)
Starter cables		T1, T2, and +		
Battery ground cable		T3 G1 and -		
Engine ground cable		T4 and T5 G2		
Engine wire harness		C101 thru C139 T101 thru T103 G101		
Right engine compartment wire harness		C201 thru C211 G201		
Left engine compartment wire harness		C301 thru C326 G301		
Main wire harness		C420 thru C435 and C484	C401 thru C419 C436 thru C483 G401, G402, G403, and G404	
Right side wire harness				C501 thru C514 T501 thru T509 G501, G502, G503, G504, G505
Left side wire harness				C521 thru C543 G521 G522
Rear wire harness				C551 thru C559 G551
Dashboard wire harness			C601 thru C622	
Roof wire harness				C651 thru C655
SRS main harness				C701 thru C707 G701
Driver's door wire harness				C721 thru C731
Passenger's door wire harness				C741 thru C748
Rear window defogger ground wire				C801 G801
A/C wire harness		C381 thru C386 G381		

Connector Identification and Wire Harness Routing

Starter Cables

Connector or Terminal	Number of Cavities	Location	Connects to	Notes
T1		Right side of engine compartment	Under-hood fuse/relay box Starter motor	
T2		Right side of engine compartment		
⊕		Battery	Battery positive terminal	

Battery Ground Cables

Connector or Terminal	Number of Cavities	Location	Connects to	Notes
T3		Middle of engine compartment	Transmission housing	
G1		Right side of engine compartment	Body ground, via battery ground cables	
⊖		Battery	Battery negative terminal	

Engine Ground Cables

Connector or Terminal	Number of Cavities	Location	Connects to	Notes
T4		Middle of engine compartment	Engine mount bracket Valve cover	
T5		Middle of engine compartment		
G2		Left side of engine compartment	Body ground, via engine ground cables	

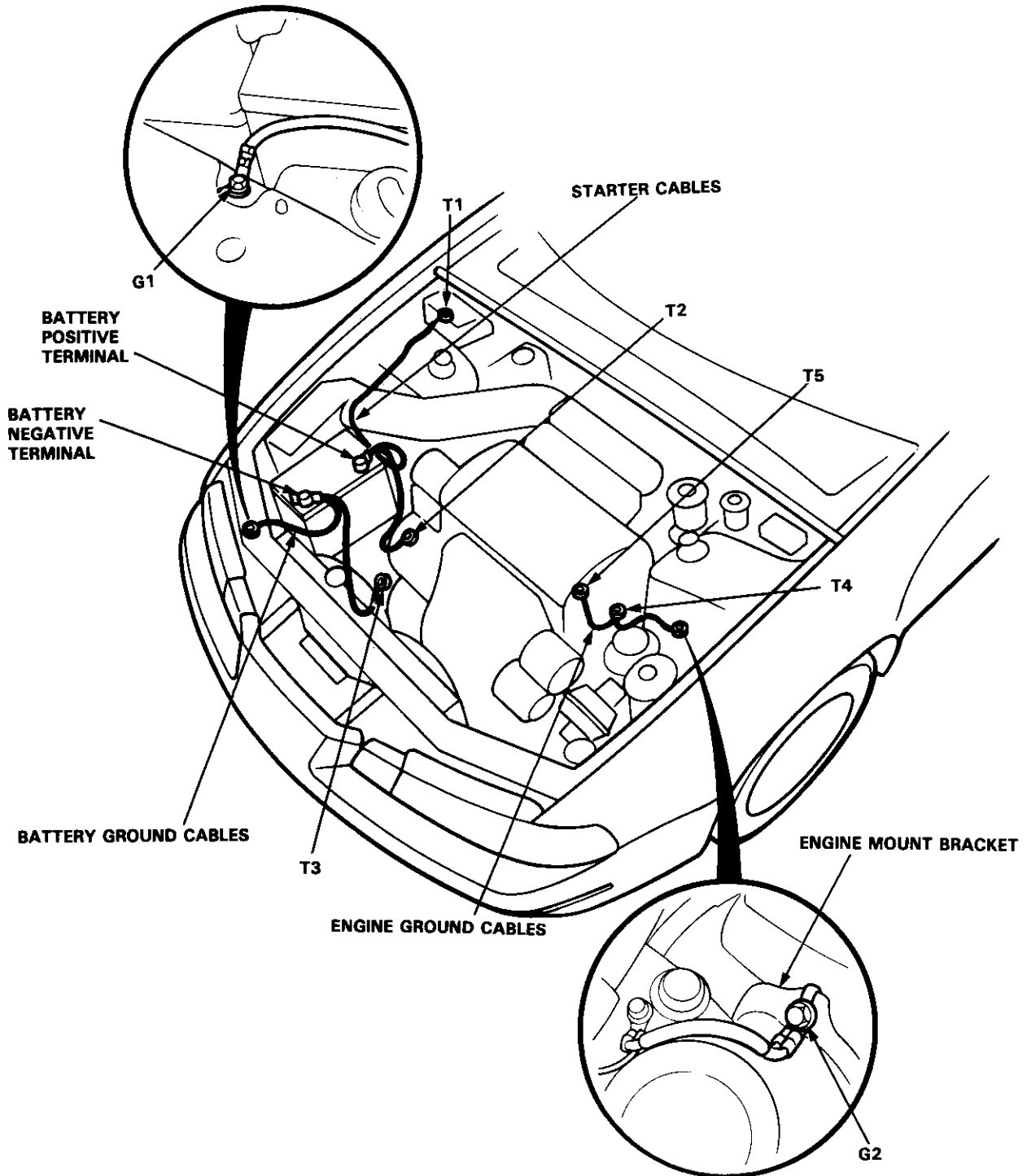

Connector Identification and Wire Harness Routing

Engine Wire Harness (F22A1 Engine: 2.2 l SOHC)

Connector or Terminal	Number of Cavities	Location	Connects to	Notes
C101	4	Left side of engine compartment	Alternator	
C102	2	Middle of engine	No. 1 fuel injector	
C103	2	Middle of engine	No. 2 fuel injector	
C104	2	Middle of engine	No. 3 fuel injector	
C105	2	Middle of engine	No. 4 fuel injector	
C106	2	Middle of engine compartment	Idle air control (IAC) valve	
C107	6	Left side of engine compartment	Injector resistor	
C108	2	Middle of engine compartment	Intake air temperature (IAT) sensor	
C110	2	Middle of engine compartment	Power steering pressure (PSP) switch	
C111	1	Middle of engine	Engine oil pressure switch	
C113	3	Middle of engine compartment	Throttle position (TP) sensor	
C114	4	Middle of engine	Heated oxygen sensor (HO2S)	
C115	3	Middle of engine	Vehicle speed sensor (VSS)	
C116	2	Middle of engine	Countershaft speed sensor	A/T
C117	3	Middle of engine	EGR valve lift sensor	
C118	2	Middle of engine	Engine coolant temperature (ECT) switch A	
C119	1	Middle of engine	Back-up light switch (-)	M/T
C120	1	Middle of engine	Back-up light switch (+)	M/T
C121	4	Middle of engine	Ignition coil	
C122	2	Middle of engine	Engine coolant temperature (ECT) sensor	
C123	1	Middle of engine	Engine coolant temperature (ECT) sending unit	
C124	1	Middle of engine	Starter solenoid	
C125	8	Middle of engine	TDC/CKP/CYP sensor	
C126	2	Middle of engine	Ignition control module (ICM)	
C127	2	Middle of engine	Engine coolant temperature (ECT) switch B	
C128	2	Middle of engine	Mainshaft speed sensor	A/T
C129	2	Middle of engine	Lock-up control solenoid valve	A/T
C130	3	Middle of engine	Shift control solenoid valve	A/T
C131	10	Right side of engine compartment	Junction connector	
C132	2	Right side of engine compartment	Main wire harness (C428)	
C133	14	Right side of engine compartment	Main wire harness (C425)	
C134	10	Right side of engine compartment	Main wire harness (C426)	
C135	10	Right side of engine compartment	Main wire harness (C432)	A/T
C135	4	Right side of engine compartment	Main wire harness (C432)	M/T
C136	14	Right side of engine compartment	Main wire harness (C433)	
T101		Right side of engine compartment	Under-hood fuse/relay box	
T102		Left side of engine compartment	Alternator	
G101		Middle of engine	Engine ground, via engine wire harness	

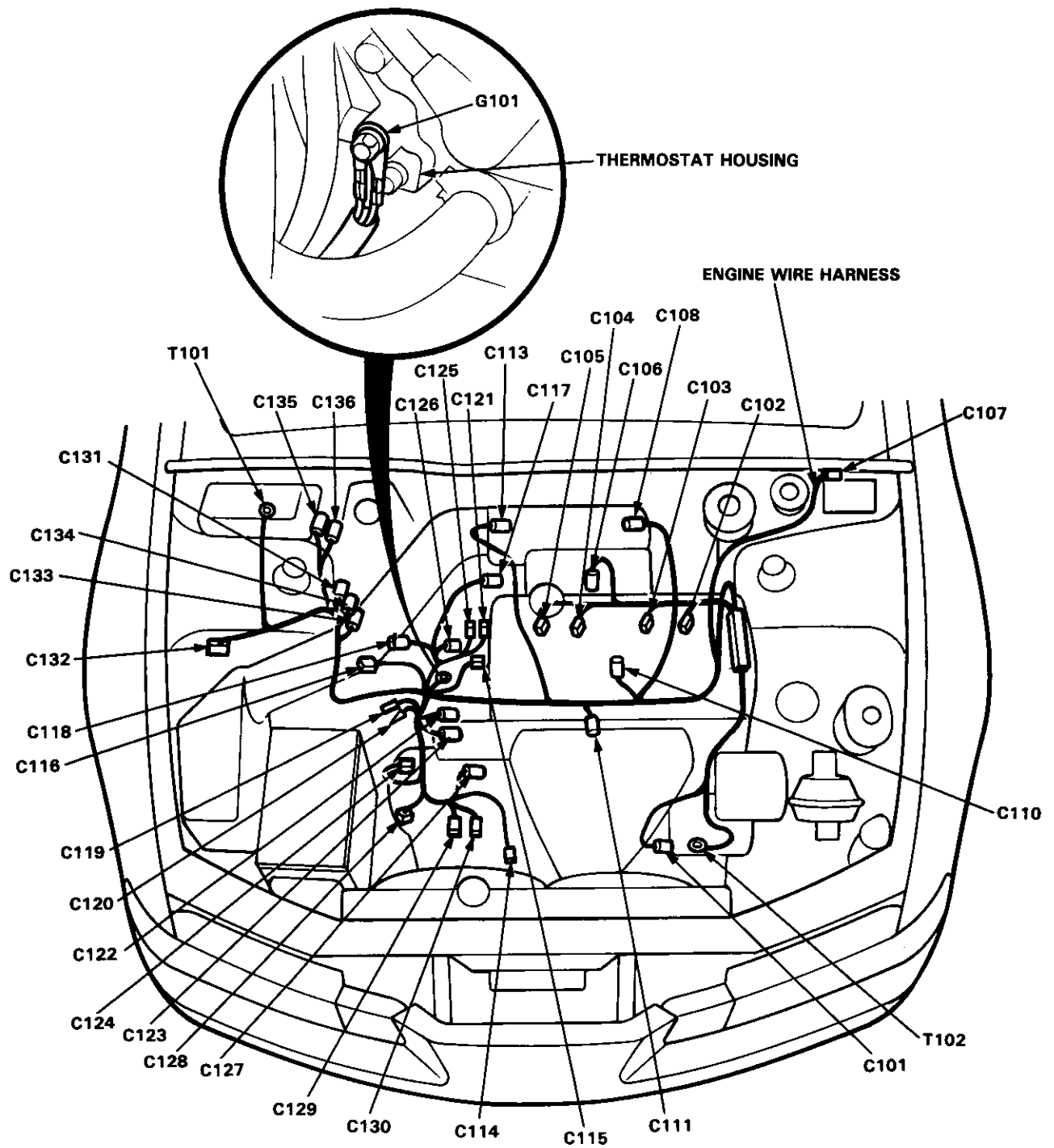

Connector Identification and Wire Harness Routing

Engine Wire Harness (H22A1 Engine: 2.2 l VTEC)

Connector or Terminal	Number of Cavities	Location	Connects to	Notes
C101	4	Left side of engine compartment	Alternator	
C102	2	Middle of engine	No. 1 fuel injector	
C103	2	Middle of engine	No. 2 fuel injector	
C104	2	Middle of engine	No. 3 fuel injector	
C105	2	Middle of engine	No. 4 fuel injector	
C106	2	Middle of engine compartment	Idle air control (IAC) valve	
C107	6	Left side of engine compartment	Injector resistor	
C108	2	Middle of engine compartment	Intake air temperature (IAT) sensor	
C109	2	Middle of engine compartment	Intake air bypass (IAB) control solenoid valve	
C110	2	Middle of engine compartment	Power steering pressure (PSP) switch	
C112	2	Middle of engine	Knock sensor (KS)	
C113	3	Middle of engine compartment	Throttle position (TP) sensor	
C114	4	Middle of engine	Heated oxygen sensor (HO2S)	
C115	3	Middle of engine	Vehicle speed sensor (VSS)	
C117	3	Middle of engine	EGR valve lift sensor	
C118	2	Middle of engine	Engine coolant temperature (ECT) switch A	
C119	1	Middle of engine	Back-up light switch (-)	
C120	1	Middle of engine	Back-up light switch (+)	
C121	4	Middle of engine	Ignition coil	
C122	2	Middle of engine	Engine coolant temperature (ECT) sensor	
C123	1	Middle of engine	Engine coolant temperature (ECT) sending unit	
C124	1	Middle of engine	Starter solenoid	
C125	8	Middle of engine	TDC/CKP/CYP sensor	
C126	2	Middle of engine	Ignition control module (ICM)	
C127	2	Middle of engine	Engine coolant temperature (ECT) switch B	
C131	10	Right side of engine compartment	Junction connector	
C132	2	Right side of engine compartment	Main wire harness (C428)	
C133	14	Right side of engine compartment	Main wire harness (C425)	
C134	10	Right side of engine compartment	Main wire harness (C426)	
C135	4	Right side of engine compartment	Main wire harness (C432)	
C136	14	Right side of engine compartment	Main wire harness (C433)	
C137	2	Middle of engine	VTEC pressure switch	
C138	1	Middle of engine	VTEC valve	
C139	1	Right side of engine compartment	Main wire harness (C484)	
T101		Right side of engine compartment	Under-hood fuse/relay box	
T102		Left side of engine compartment	Alternator	
T103		Middle of engine	Engine oil pressure switch	
G101		Middle of engine	Engine ground, via engine wire harness	

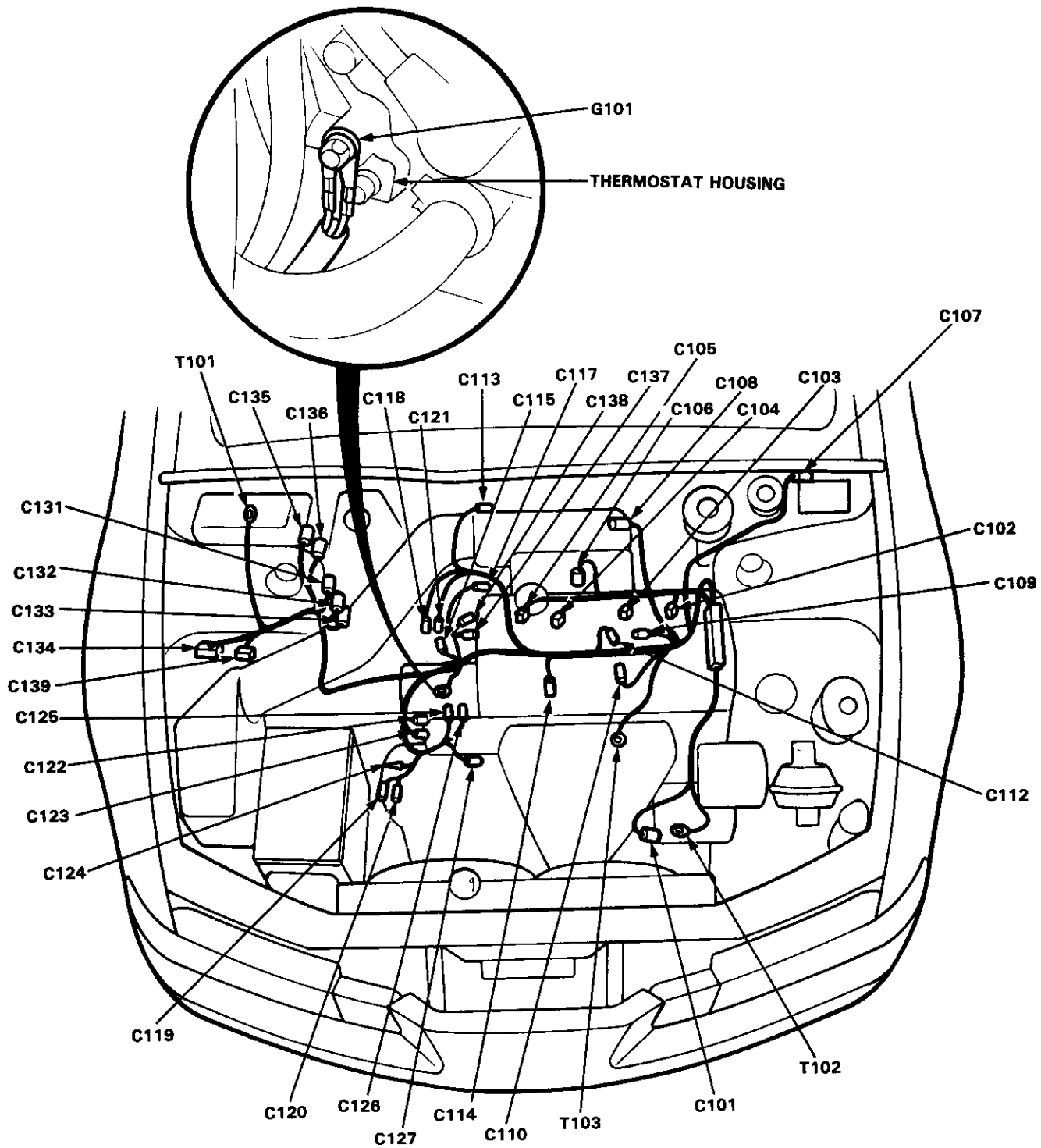

Connector Identification and Wire Harness Routing

Engine Wire Harness (H23A1 Engine: 2.3 l DOHC)

Connector or Terminal	Number of Cavities	Location	Connects to	Notes
C101	4	Left side of engine compartment	Alternator	
C102	2	Middle of engine	No. 1 fuel injector	
C103	2	Middle of engine	No. 2 fuel injector	
C104	2	Middle of engine	No. 3 fuel injector	
C105	2	Middle of engine	No. 4 fuel injector	
C106	2	Middle of engine compartment	Idle air control (IAC) valve	
C107	6	Left side of engine compartment	Injector resistor	
C108	2	Middle of engine compartment	Intake air temperature (IAT) sensor	
C109	2	Middle of engine compartment	Intake air bypass (IAB) control solenoid valve	
C110	2	Middle of engine compartment	Power steering pressure (PSP) switch	
C112	2	Middle of engine	Knock sensor (KS)	
C113	3	Middle of engine compartment	Throttle position (TP) sensor	
C114	4	Middle of engine	Heated oxygen sensor (HO2S)	
C115	3	Middle of engine	Vehicle speed sensor (VSS)	
C116	2	Middle of engine	Countershaft speed sensor	A/T
C117	3	Middle of engine	EGR valve lift sensor	
C118	2	Middle of engine	Engine coolant temperature (ECT) switch A	M/T
C119	1	Middle of engine	Back-up light switch (-)	M/T
C120	1	Middle of engine	Back-up light switch (+)	
C121	4	Middle of engine	Ignition coil	
C122	2	Middle of engine	Engine coolant temperature (ECT) sensor	
C123	1	Middle of engine	Engine coolant temperature (ECT) sending unit	
C124	1	Middle of engine	Starter solenoid	
C125	8	Middle of engine	TDC/CKP/CYP sensor	
C126	2	Middle of engine	Ignition control module (ICM)	
C127	2	Middle of engine	Engine coolant temperature (ECT) switch B	
C128	2	Middle of engine	Mainshaft speed sensor	A/T
C129	2	Middle of engine	Lock-up control solenoid valve	A/T
C130	3	Middle of engine	Shift control solenoid valve	A/T
C131	10	Right side of engine compartment	Junction connector	
C132	2	Right side of engine compartment	Main wire harness (C428)	
C133	14	Right side of engine compartment	Main wire harness (C425)	
C134	10	Right side of engine compartment	Main wire harness (C426)	
C135	10	Right side of engine compartment	Main wire harness (C432)	A/T
C135	4	Right side of engine compartment	Main wire harness (C432)	M/T
C136	14	Right side of engine compartment	Main wire harness (C433)	
T101		Right side of engine compartment	Under-hood fuse/relay box	
T102		Left side of engine compartment	Alternator	
T103		Middle of engine	Engine oil pressure switch	
G101		Middle of engine	Engine ground, via engine wire harness	

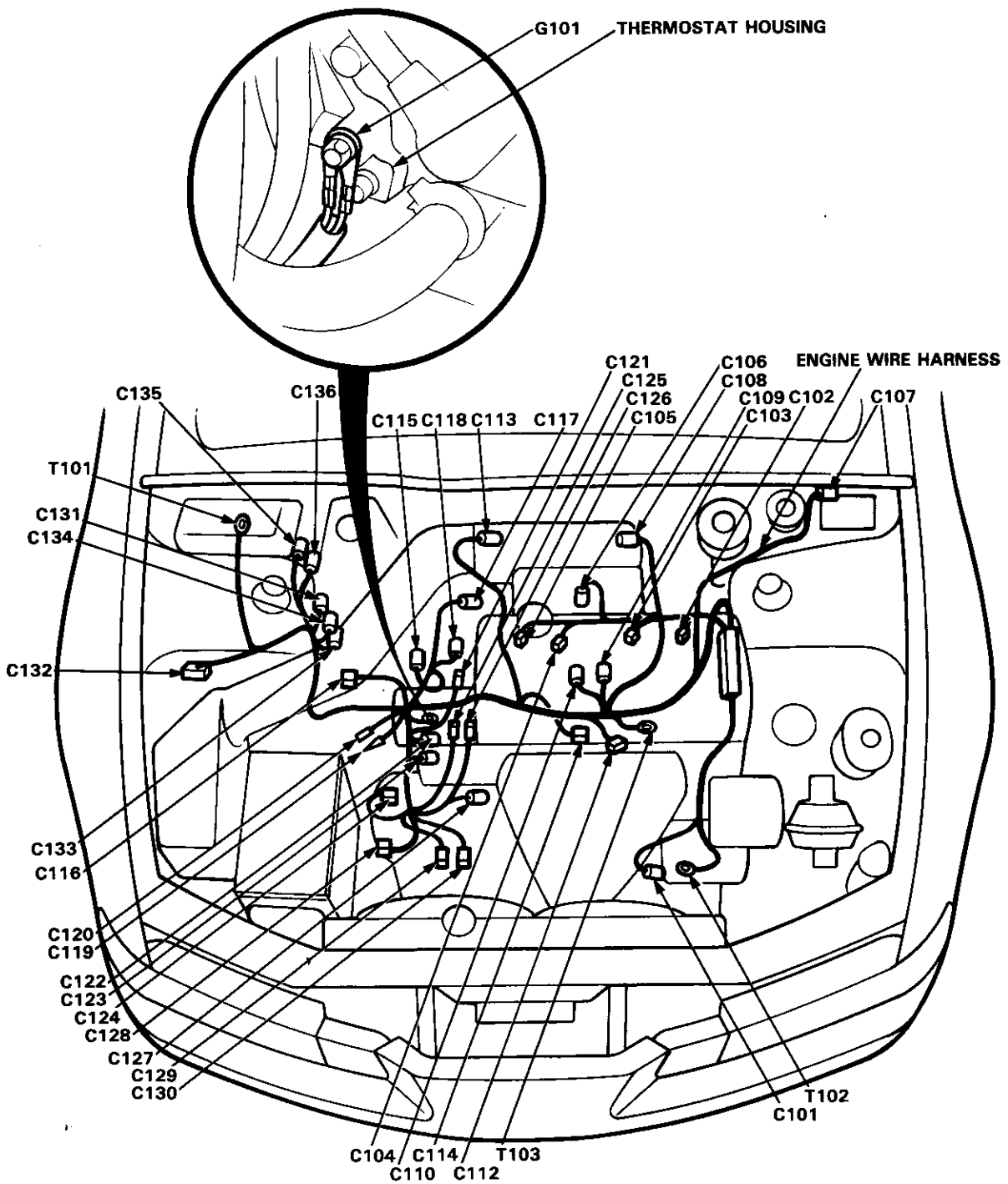

Connector Identification and Wire Harness Routing

Right Engine Compartment Wire Harness

Connector or Terminal	Number of Cavities	Location	Connects to	Notes
C201	2	Middle of engine compartment	Right horn	OPTION
C202	2	Middle of engine compartment	Left horn	
C203	2	Middle of engine compartment	A/C pressure switch	
C204	2	Behind right front side marker light	Right front side marker light	
C205	2	Behind front bumper	Right front turn signal light	
C206	2	Behind front bumper	Right front fog light	
C207	2	Behind right headlight	Right headlight (High beam)	
C208	2	Middle of engine compartment	Radiator fan motor	
C209	2	Behind right headlight	Right headlight (Low beam)	
C210	2	Behind right headlight	Right front parking light	
C211	22	Behind right kick panel	Main wire harness (C401)	
G201		Right side of engine compartment	Body ground, via main wire harness	

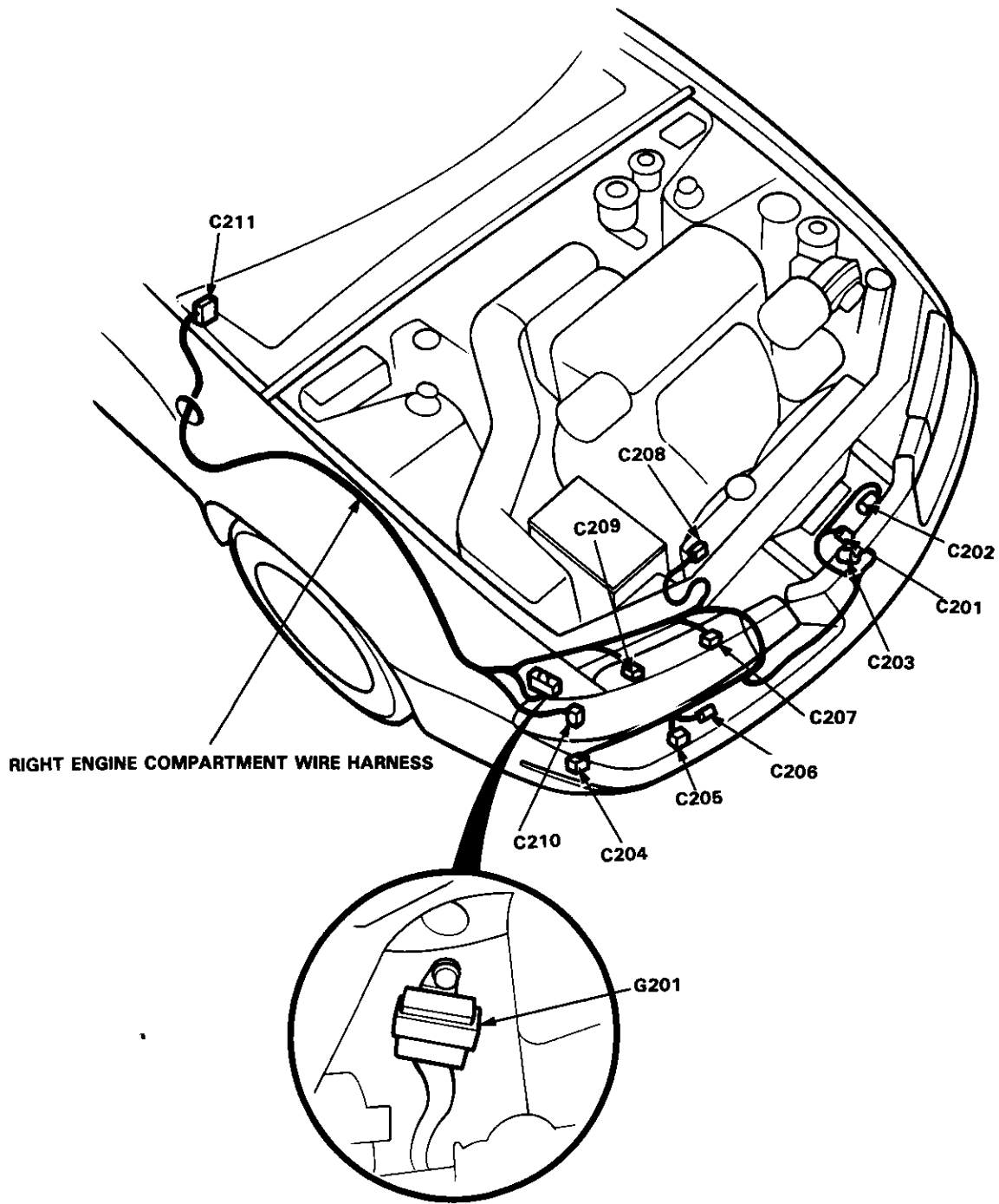

Connector Identification and Wire Harness Routing

Left Engine Compartment Wire Harness

Connector or Terminal	Number of Cavities	Location	Connects to	Notes
C301	2	Behind left front side marker light	Left front side marker light	OPTION A/C A/C
C302	2	Behind front bumper	Left front turn signal light	
C303	2	Behind front bumper	Left front fog light	
C304	2	Behind left headlight	Left headlight (High beam)	
C305	1	Middle of engine compartment	A/C compressor clutch	
C306	2	Behind radiator	Condenser fan motor	
C307	2	Behind left headlight	Left headlight (Low beam)	
C308	4	Left side of engine compartment	Cruise control actuator	
C309	8	Left side of engine compartment	A/C wire harness (C381)	
C310	2	Left side of engine compartment	EGR control solenoid valve	ABS A/C A/C A/C 4WS
C311	2	Left side of engine compartment	Left front wheel sensor	
C312	4	Left side of engine compartment	A/C compressor clutch relay	
C313	4	Left side of engine compartment	Condenser fan relay	
C314	4	Left side of engine compartment	A/C diode	
C315	2	Behind front bumper	Windshield washer motor	
C316	2	Behind left headlight	Left front parking light	
C317	5	Left rear of engine compartment	Windshield wiper motor	
C318	1	Left side of engine compartment	Brake fluid level switch (-)	
C319	1	Left side of engine compartment	Brake fluid level switch (+)	
C320	3	Middle of engine compartment	MAP sensor	
C321	2	Middle of engine compartment	Evaporative emission (EVAP) purge control solenoid valve	
C322	6	Left side of engine compartment	Windshield wiper intermittent relay	
C323	3	Under middle of engine compartment	4WS front sub steering angle sensor	
C324	20	Behind left kick panel	Main wire harness (C462)	
C325	22	Behind left kick panel	Main wire harness (C463)	
C326	20	Behind left kick panel	Junction connector	
G301		Left side of engine compartment	Body ground, via left engine compartment wire harness	

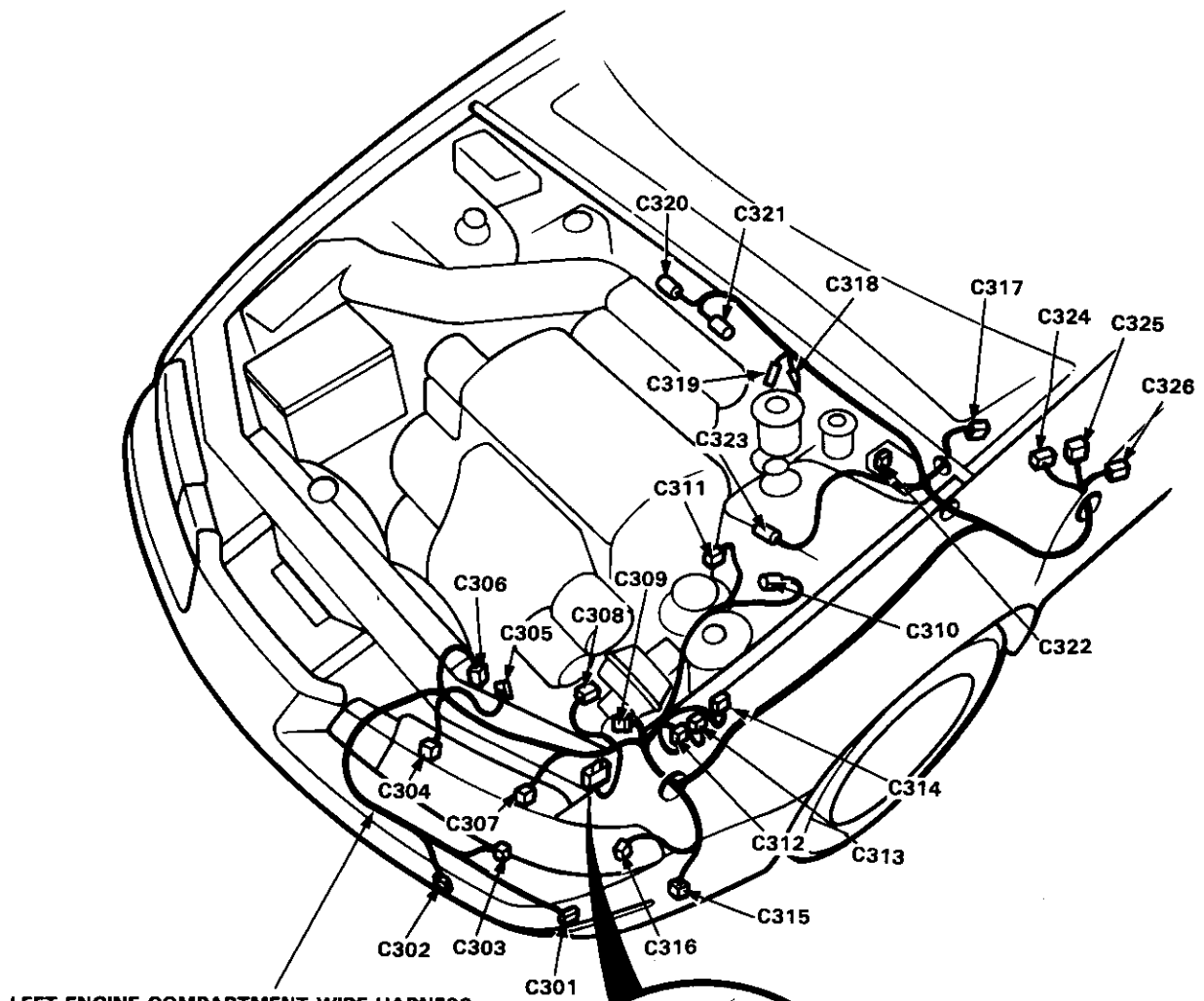

LEFT ENGINE COMPARTMENT WIRE HARNESS

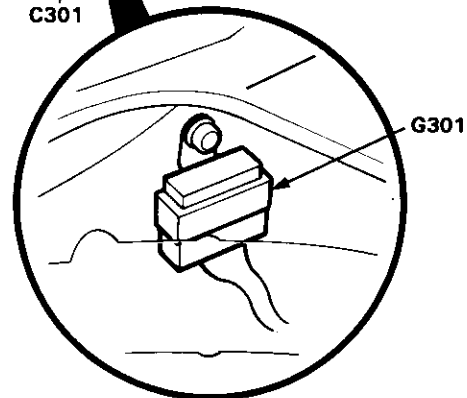

Connector Identification and Wire Harness Routing

A/C Wire Harness (With optional A/C)

Connector or Terminal	Number of Cavities	Location	Connects to	Notes
C381	8	Left side of engine compartment	Left engine compartment wire harness (C309)	
C382	4	Under left side of dash	A/C diode	
C383	4	Under left side of dash	Condenser fan relay	
C384	4	Under left side of dash	A/C compressor clutch relay	
C385	2	Under left side of dash	Condenser fan motor	
C386	1	Under left side of dash	A/C compressor clutch	
G381		Left front of engine compartment	Body ground, via A/C wire harness	



A/C WIRE HARNESS (With optional A/C)

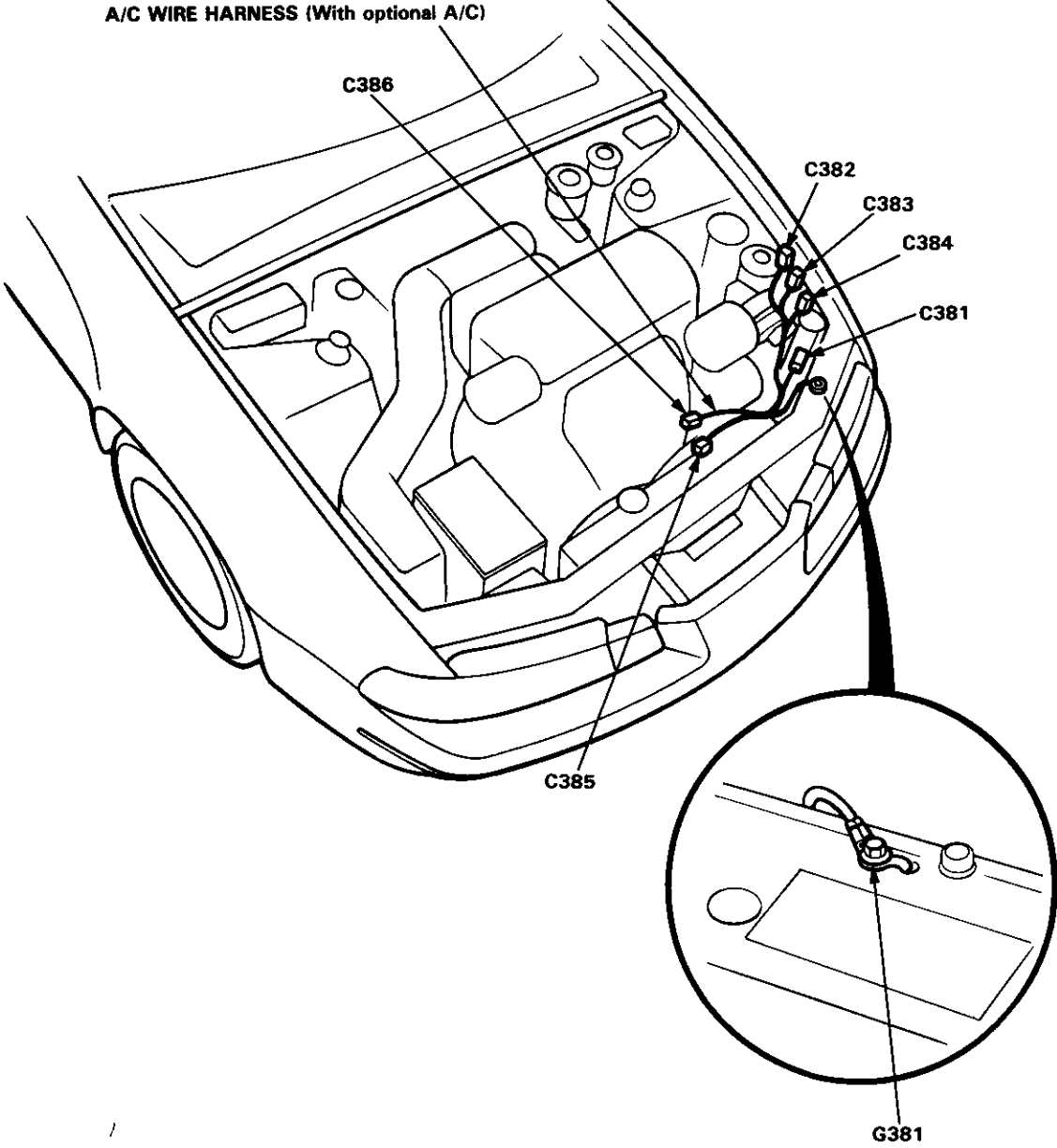

Connector Identification and Wire Harness Routing

Main Wire Harness (Right side of engine compartment branch)

Connector or Terminal	Number of Cavities	Location	Connects to	Notes
C420	3	Right side of engine compartment	Under-hood fuse/relay box (C945)	
C421	3	Right side of engine compartment	Under-hood fuse/relay box (C946)	
C422	7	Right side of engine compartment	Under-hood fuse/relay box (C947)	
C423	9	Right side of engine compartment	Under-hood fuse/relay box (C948)	
C424	11	Right side of engine compartment	Under-hood fuse/relay box (C949)	
C425	14	Right side of engine compartment	Engine wire harness (C133)	
C426	10	Right side of engine compartment	Engine wire harness (C134)	
C427	2	Right side of engine compartment	Test tachometer connector	
C428	2	Right side of engine compartment	Engine wire harness (C132)	
C429	2	Right side of engine compartment	Intake air control solenoid valve	DOHC
C430	2	Right side of engine compartment	Right front wheel sensor	ABS
C431	10	Right side of engine compartment	ABS solenoids	
C432	10	Right side of engine compartment	Engine wire harness (C135)	A/T
C432	4	Right side of engine compartment	Engine wire harness (C135)	M/T
C433	14	Right side of engine compartment	Engine wire harness (C136)	
C434	2	Right side of engine compartment	ABS pressure switch	
C435	2	Right side of engine compartment	ABS motor	
C484	1	Right side of engine compartment	Engine wire harness (139)	VTEC

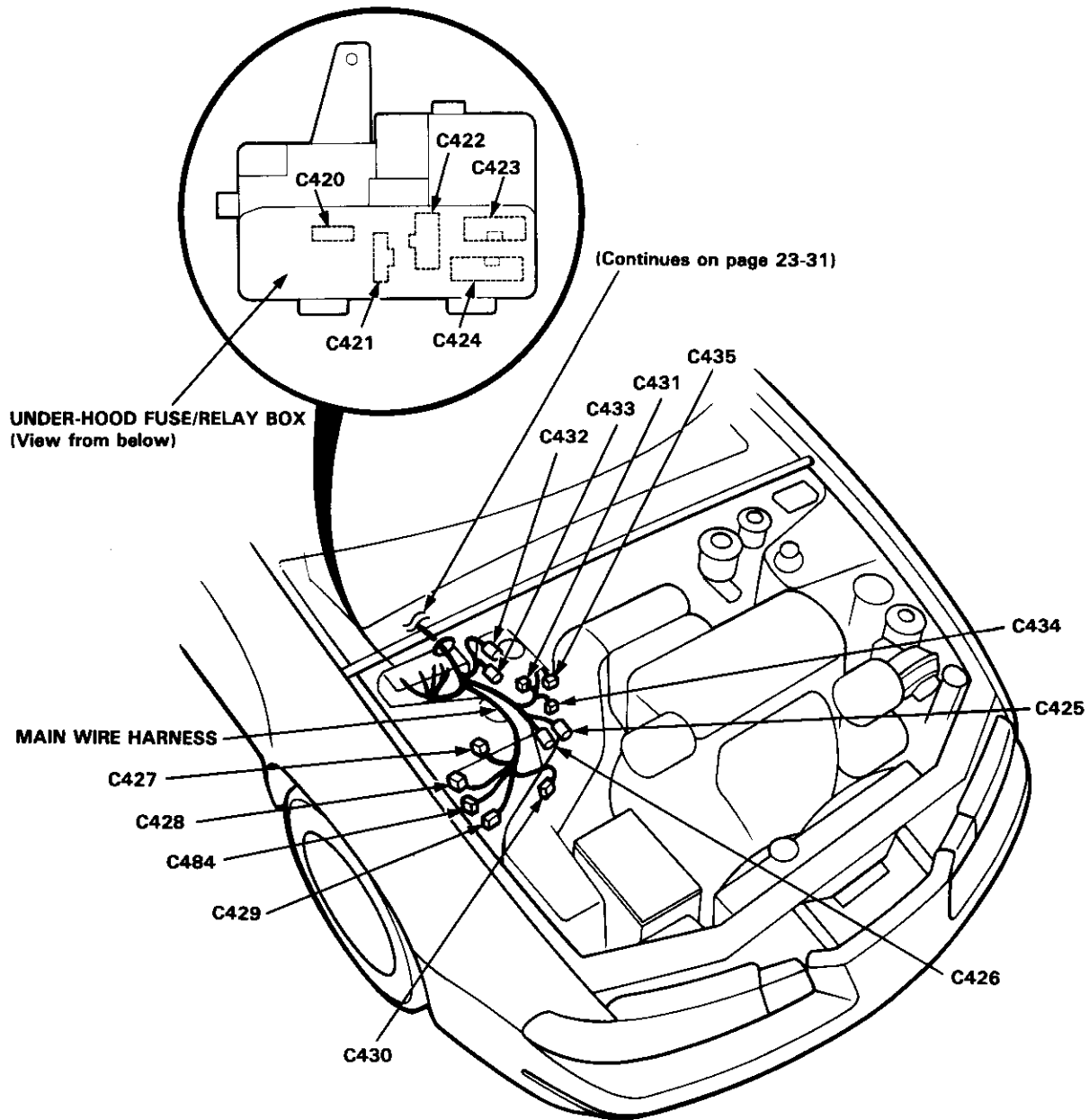

(cont'd)

Connector Identification and Wire Harness Routing

Main Wire Harness (Right side of dash and floor branch) (cont'd)

Connector or Terminal	Number of Cavities	Location	Connects to	Notes
C401	22	Under right side of dash	Right engine compartment wire harness (C211)	
C402	16	Under right side of dash	Right side wire harness (C501)	
C403	20	Under right side of dash	Right side wire harness (C502)	
C404	20	Under right side of dash	Dashboard wire harness (C620)	
C405	6	Under right side of dash	Passenger's door wire harness (C742)	
C406	10	Under right side of dash	Passenger's door wire harness (C741)	
C407	5	Under right side of dash	Blower resistor	
C408	2	Under right side of dash	Evaporator temperature sensor	
C409	4	Behind glove box	Recirculation control motor	
C410	26	Behind right kick panel	Transmission control module (TCM)	
C411	22	Behind right kick panel	Transmission control module (TCM)	
C412	20	Behind right kick panel	Junction connector	
C413	2	Behind glove box	Blower motor	
C414	20	Behind right kick panel	Junction connector	
C415	26	Under right side of dash	ECM	
C416	16	Under right side of dash	ECM	
C417	22	Under right side of dash	ECM	
C418	14	Under right side of dash	Daytime running lights control unit	Canada
C419	20	Under right side of dash	Junction connector	
C436	8	Under right side of dash	Radiator fan control module	
C437	3	Under middle of dash	Shift lock solenoid	A/T
C438	4	Under middle of dash	Cigarette lighter	
C439	16	Under middle of dash	Heater control panel	
C440	7	Under middle of dash	Blower fan switch	
C441	16	Under middle of dash	Stereo radio/cassette player	
C442	2	Under middle of dash	Service check connector	
C443	3	Under middle of dash	Data link connector (DLC)	
C444	2	Under middle of dash	A/T gear position console light	A/T
C445	12	Under middle of dash	A/T gear position switch	A/T
C446	3	Under middle of dash	A/T gear position switch (Back-up light switch)	A/T
C447	20	Behind middle of dash	Junction connector	
C448	8	Behind middle of dash	Mode control motor	
G401		Behind right side of dash	Body ground, via main wire harness	
G402		Under middle of dash	Body ground, via main wire harness	
G403		Under middle of dash	Body ground, via main wire harness	
G404		Under middle of dash	Body ground, via main wire harness	

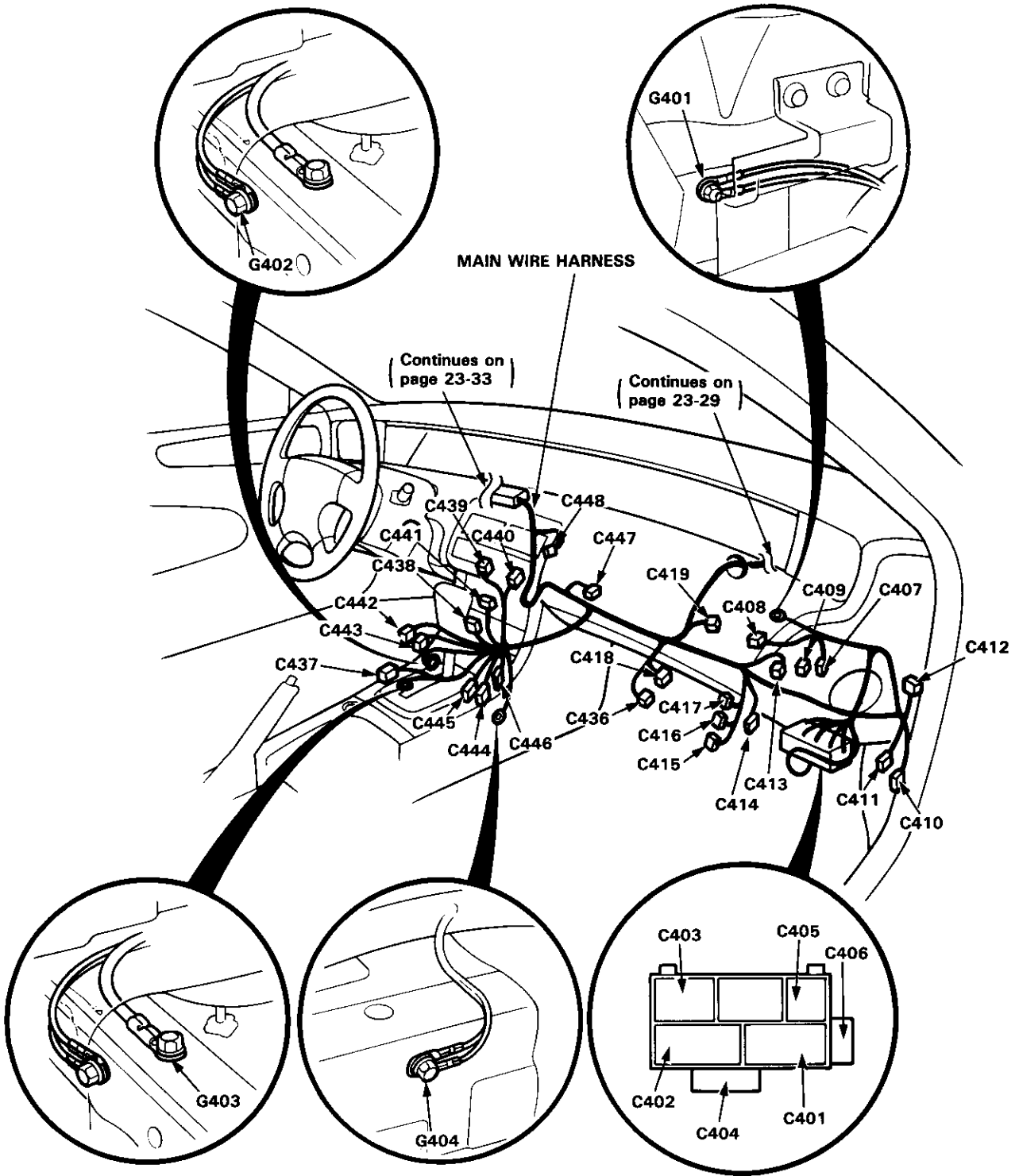

(cont'd)

Connector Identification and Wire Harness Routing

Main Wire Harness (Left side of dash and floor branch) (cont'd)

Connector or Terminal	Number of Cavities	Location	Connects to	Notes
C449	20	Under left side of dash	Junction connector	
C450	8	Under left side of dash	Ignition switch	
C451	3	Under left side of dash	Ignition switch	
C452	5	Under left side of dash	Combination light switch	
C453	8	Under left side of dash	Driver's door wire harness (C722)	
C454	14	Under left side of dash	Driver's door wire harness (C721)	
C455	10	Under left side of dash	Front main steering angle sensor	4WS
C456	2	Under left side of dash	Lights-on chime	
C457	8	Under left side of dash	Interlock control unit	A/T
C458	2	Under left side of dash	Clutch interlock switch	M/T
C459	3	Under left side of dash	Clutch switch	CRUISE
C460	20	Under left side of dash	Junction connector	
C461	20	Under left side of dash	Left side wire harness (C522)	
C462	20	Under left side of dash	Left engine compartment wire harness (C324)	
C463	22	Under left side of dash	Left engine compartment wire harness (C325)	
C464	20	Under left side of dash	Dashboard wire harness (C602)	
C465	4	Under left side of dash	Front fog light relay	OPTION
C466	3	Under left side of dash	Under-dash fuse/relay box (C918)	
C467	4	Under left side of dash	Under-dash fuse/relay box (C922)	
C468	8	Under left side of dash	Under-dash fuse/relay box (C920)	
C469	14	Under left side of dash	Under-dash fuse/relay box (C915)	
C470	14	Under left side of dash	Under-dash fuse/relay box (C914)	
C471	22	Under left side of dash	Under-dash fuse/relay box (C916)	
C472	5	Under left side of dash	Under-dash fuse/relay box (C919)	
C473	16	Under left side of dash	Integrated control unit	
C474	4	Under left side of dash	Starter cut relay	M/T
C475	4	Under left side of dash	Cigarette lighter relay	
C476	4	Under left side of dash	Horn relay	SRS
C477	14	Under left side of dash	Cruise control unit	
C478	4	Under left side of dash	SRS main harness (C706)	SRS
C479	4	Under left side of dash	Brake light switch	CRUISE
C479	2	Under left side of dash	Brake light switch	
C480	4	Under left side of dash	ABS front fail-safe relay	
C481	4	Under left side of dash	ABS rear fail-safe relay	
C482	4	Under left side of dash	Seat heater main relay	Canada
C483	7	Under left side of dash	PGM-FI main relay	



(Continues on page 23-31)

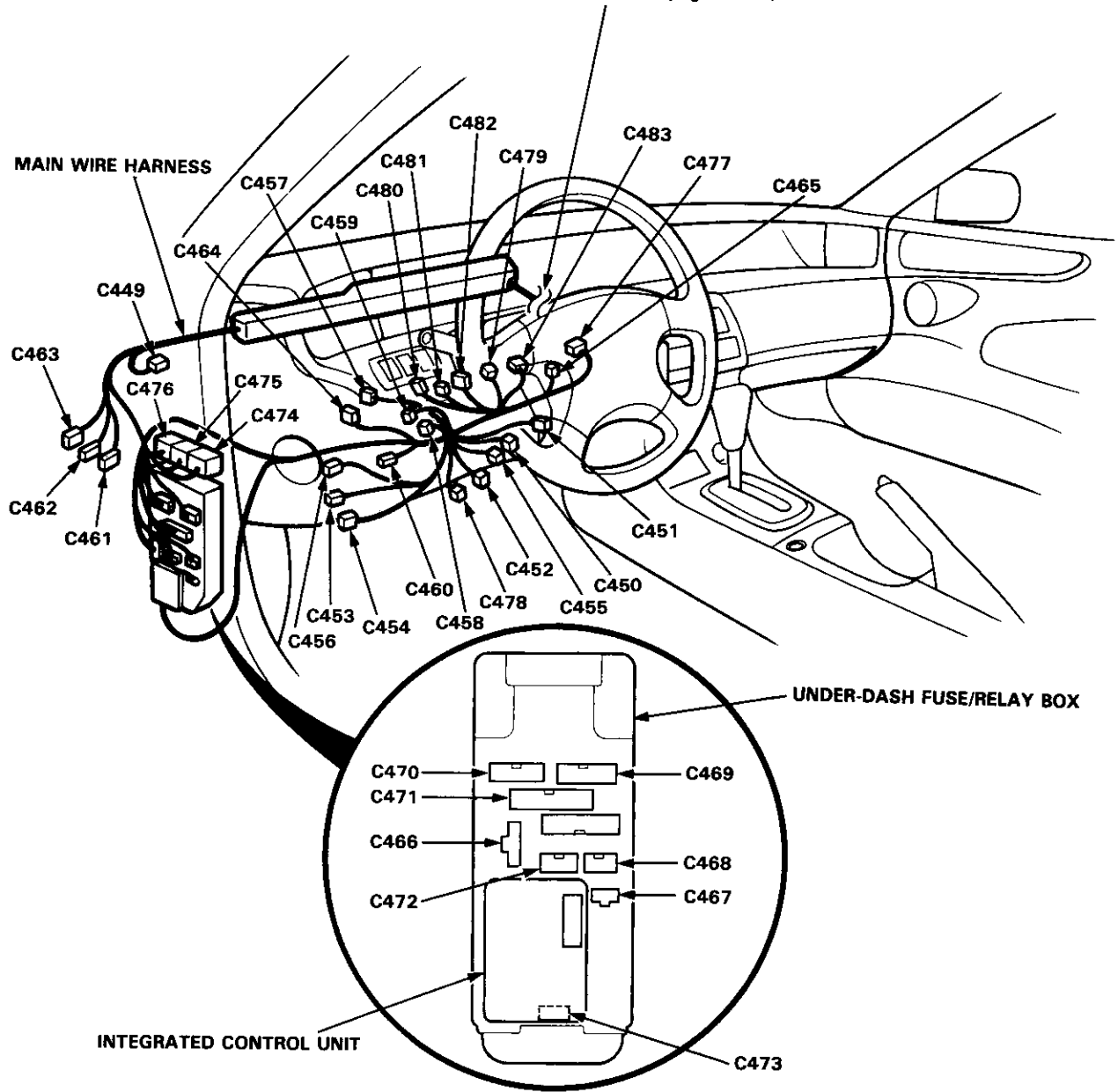

Connector Identification and Wire Harness Routing

Right Side Wire Harness

Connector or Terminal	Number of Cavities	Location	Connects to	Notes
C501	16	Under right side of dash	Main wire harness (C402)	
C502	20	Under right side of dash	Main wire harness (C403)	
C503	16	Under right side of dash	Dashboard wire harness (621)	
C504	6	Right side of floor	ABS inspection connector	ABS
C505	14	Right quarter panel	ABS control unit	4WS
C505	12	Right quarter panel	ABS control unit	
C506	20	Right quarter panel	ABS control unit	4WS
C506	18	Right quarter panel	ABS control unit	
C507	20	Right quarter panel	Junction connector	
C508	4	Left front of trunk	4WS control unit	4WS
C509	18	Left front of trunk	4WS control unit	4WS
C510	12	Left front of trunk	4WS control unit	4WS
C511	2	Inside of right rear wheel	Right rear wheel sensor	ABS
C512	2	Inside of right rear wheel	Left rear wheel sensor	ABS
C513	3	Under middle of trunk	4WS rear differential transformer	4WS
C514	8	Under middle of trunk	Rear main steering angle sensor	4WS
T501		Right side of engine compartment	Under-hood fuse/relay box	
T502		Left front of trunk	4WS control unit	4WS
T503		Left front of trunk	4WS control unit	4WS
T504		Left front of trunk	4WS control unit	4WS
T505		Left front of trunk	4WS control unit	4WS
T506		Under middle of trunk	Rear steering motor	4WS
T507		Under middle of trunk	Rear steering motor	4WS
T508		Under middle of trunk	Rear steering motor	4WS
T509		Under middle of trunk	Rear steering motor	4WS
G501		Right side of rear floor	Body ground, via right side wire harness	
G502		Middle front of trunk	Body ground, via right side wire harness	
G503		Middle front of trunk	Body ground, via right side wire harness	
G504		Middle front of trunk	Body ground, via right side wire harness	
G505		Under middle of trunk	Body ground, via right side wire harness	

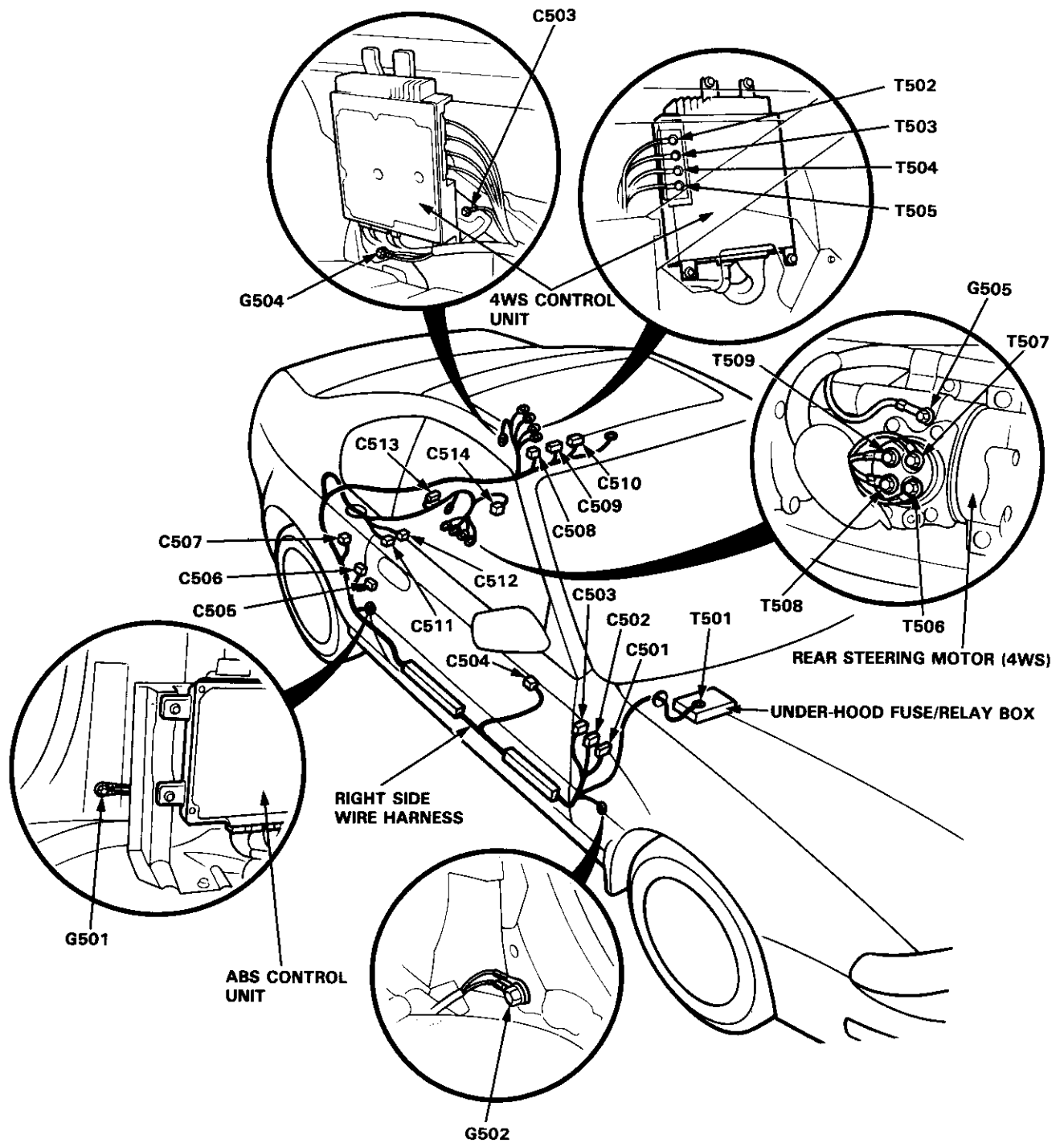

Connector Identification and Wire Harness Routing

Left Side Wire Harness

Connector or Terminal	Number of Cavities	Location	Connects to	Notes
C521	14	Under left side of dash	Dashboard wire harness (C603)	
C522	20	Under left side of dash	Main wire harness (C461)	
C523	16	Behind left kick panel	Under-dash fuse/relay box (C917)	
C524	6	Middle of center floor	Hazard warning switch	
C525	1	Middle of center floor	Parking brake switch	
C526	6	Middle of center floor	Passenger's seat heater switch	Canada
C527	6	Middle of center floor	Driver's seat heater switch	Canada
C528	18	Left front of trunk	Rear wire harness (C551)	
C529	2	Right side of floor	Passenger's seat heater	Canada
C530	2	Left side of floor	Driver's seat heater	Canada
C531	3	Left side of floor	Driver's seat belt switch	
C532	1	Right quarter panel	Passenger's door switch	
C533	1	Left quarter panel	Driver's door switch	
C534	20	Left quarter panel	Junction connector	
C535	20	Left side of rear shelf	Roof wire harness (C651)	
C536	5	Fuel tank	Fuel gauge sending unit	
C537	2	Fuel tank	Fuel pump	
C538	2	Right side of rear shelf	Right rear speaker	
C539	2	Middle of rear shelf	Trunk light	
C540	2	Left side of rear shelf	Left rear speaker	
C541	2	Behind rear console panel	Woofers speaker	VTEC
C542	10	Behind rear console panel	Woofers amplifier	VTEC
C543	20	Left side of floor	Junction connector	VTEC
G521		Left side of floor	Body ground, via left side wire harness	
G522		Right quarter panel	Body ground, via left side wire harness	

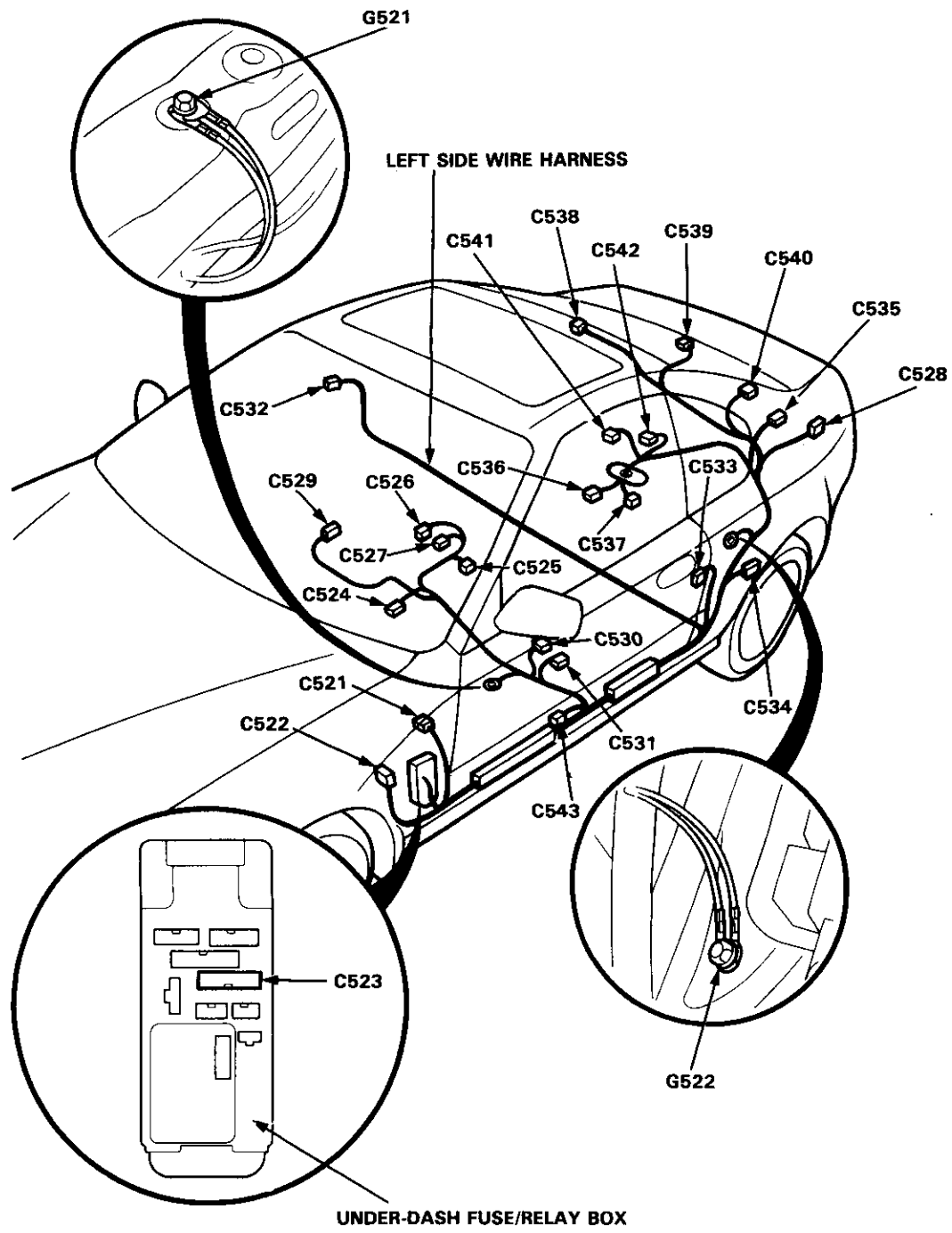

Connector Identification and Wire Harness Routing

Rear Wire Harness

Connector or Terminal	Number of Cavities	Location	Connects to	Notes
C551	18	Left front of trunk	Left side wire harness (C528)	
C552	2	Middle of trunk	Left license light	
C553	2	Middle of trunk	Trunk latch switch	
C554	2	Middle of trunk	Right license light	
C555	8	Left side of trunk	Left taillight	
C556	2	Left side of trunk	Left rear side marker light	
C557	2	Right side of trunk	Right rear side marker light	
C558	3	Right side of trunk	Power antenna motor	
C559	8	Right side of trunk	Right taillight	
G551		Middle of trunk	Body ground, via rear wire harness	

Roof Wire Harness

Connector or Terminal	Number of Cavities	Location	Connects to	Notes
C651	20	Left side of rear shelf	Left side wire harness (C535)	
C652	1	Rear of roof	Rear window defogger	
C653	2	Rear of roof	Sunroof motor	
C654	3	Rear of roof	Ceiling light	
C655	3	Rear of roof	High mount brake light	

Rear Window Defogger Ground Wire

Connector or Terminal	Number of Cavities	Location	Connects to	Notes
C801	1	Rear of roof	Rear window defogger	
G801		Rear of roof	Body ground, via rear window defogger ground wire	

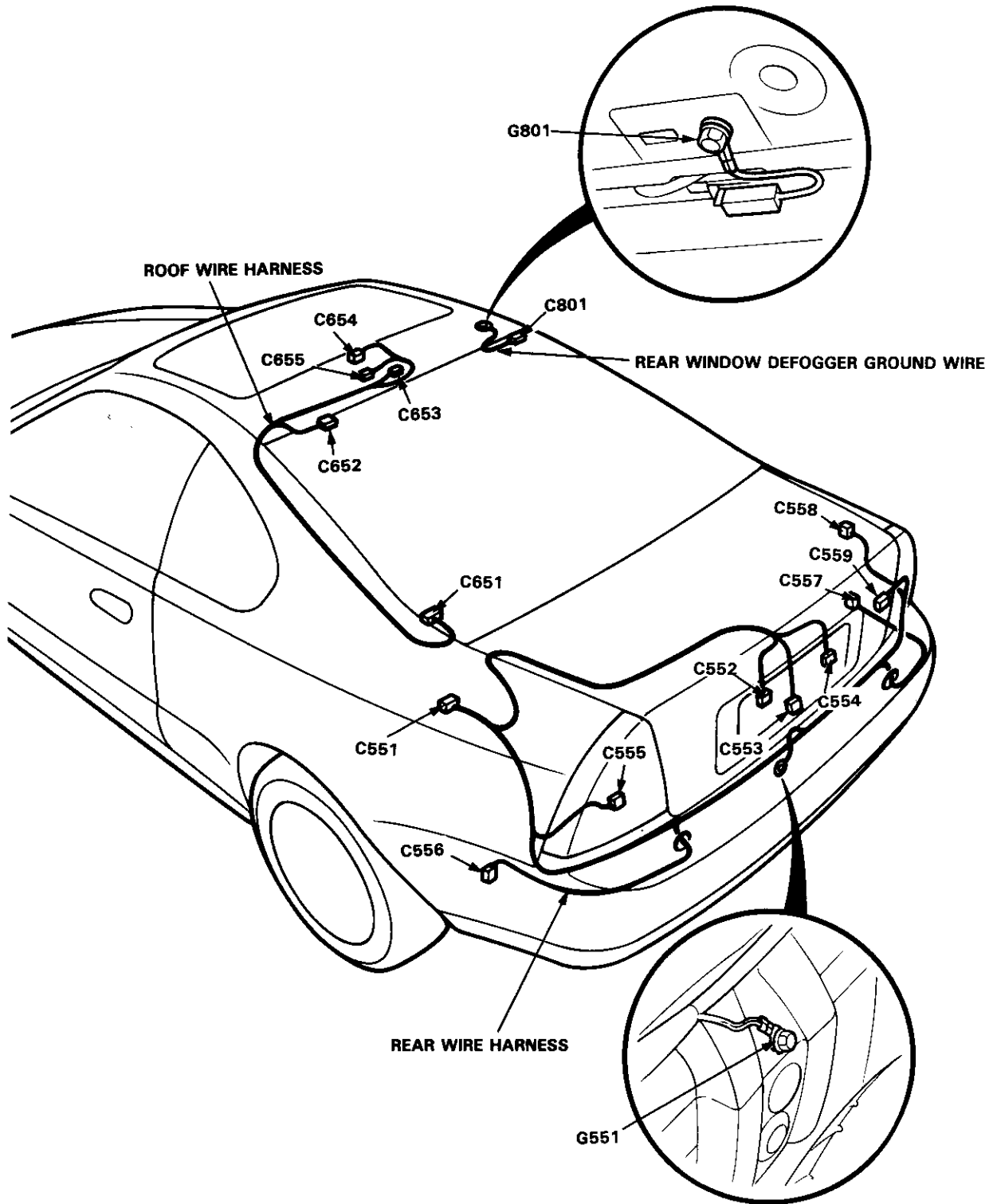

Connector Identification and Wire Harness Routing

Dashboard Wire Harness

Connector or Terminal	Number of Cavities	Location	Connects to	Notes
C601	16	Behind left kick panel	Under-dash fuse/relay box (C907)	CRUISE
C602	20	Under left side of dash	Main wire harness (C464)	
C603	14	Under left side of dash	Left side wire harness (C521)	
C604	5	Under left side of dash	Dash lights brightness controller	
C605	6	Under left side of dash	Cruise control main switch	
C606	5	Under left side of dash	Sunroof switch	
C607	1	Under left side of dash	Left front tweeter	
C608	1	Under left side of dash	Left front tweeter	
C609	20	Under left side of dash	Junction connector	
C610	10	Behind main gauge assembly	Main gauge assembly	
C611	5	Behind main gauge assembly	Main gauge assembly	
C612	16	Behind main gauge assembly	Main gauge assembly	
C613	10	Behind sub gauge assembly	Sub gauge assembly	
C614	30	Behind sub gauge assembly	Sub gauge assembly	
C615	5	Behind sub gauge assembly	Clock	
C616	6	Behind middle of dash	Dash lights brightness control unit	
C617	1	Under right side of dash	Right front tweeter	
C618	1	Under right side of dash	Right front tweeter	
C619	20	Under right side of dash	Junction connector	
C620	20	Under right side of dash	Main wire harness (C404)	
C621	16	Under right side of dash	Right side wire harness (C503)	OPTION
C622	10	Under left side of dash	Front fog light switch	

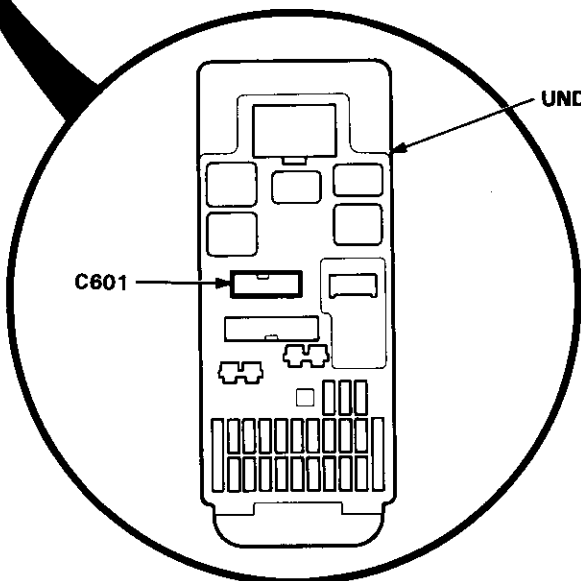
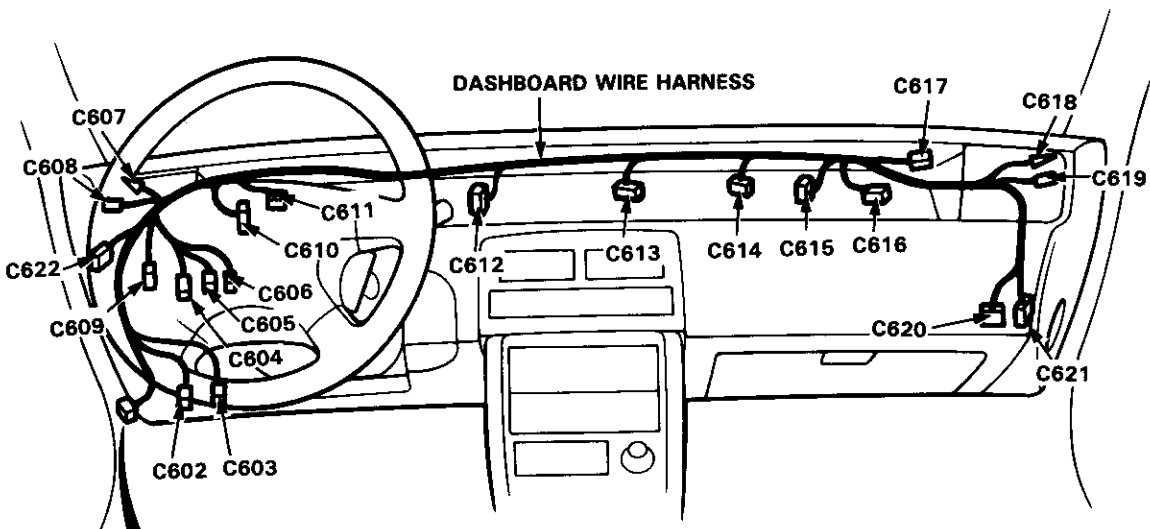

Connector Identification and Wire Harness Routing

SRS Main Harness

Connector or Terminal	Number of Cavities	Location	Connects to	Notes
C701	2	Behind left kick panel	Under-dash fuse/relay box (C931)	4WS, VTEC
C702	2	Under left side of dash	Left dash sensor	
C703	2	Under right side of dash	Right dash sensor	
C704	18	Middle of floor	SRS unit	
C705	3	Under right side of dash	Passenger's airbag assembly	
C706	4	Under left side of dash	Main wire harness (C478)	
C707	6	Under left side of dash	Cable reel	
G701		Middle of floor	Body ground, via SRS main harness	

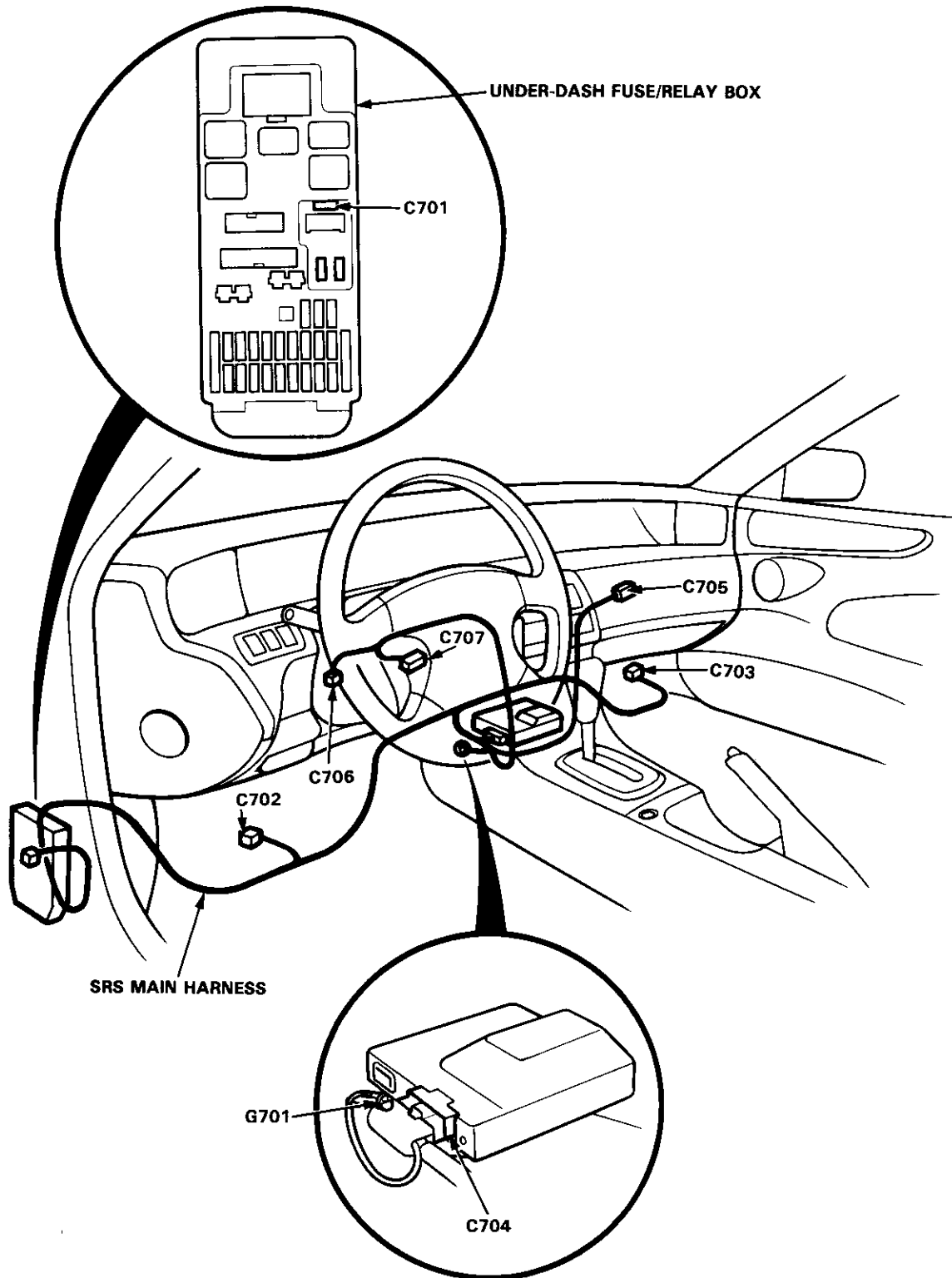

Connector Identification and Wire Harness Routing

Driver's Door Wire Harness

Connector or Terminal	Number of Cavities	Location	Connects to	Notes
C721	14	Driver's door	Main wire harness (C454)	
C722	8	Driver's door	Main wire harness (C453)	
C723	2	Driver's door	Driver's door speaker	
C724	4	Driver's door	Driver's power window motor	
C725	6	Driver's door	Driver's door lock actuator	
C726	18	Driver's door	Power door lock control unit	
C727	2	Driver's door	Power mirror defogger switch	Canada
C728	10	Driver's door	Power mirror switch	
C729	3	Driver's door	Driver's power mirror actuator	USA
C729	6	Driver's door	Driver's power mirror actuator	Canada
C730	3	Driver's door	Driver's door lock switch	
C731	10	Driver's door	Master power window switch	

Passenger's Door Wire Harness

Connector or Terminal	Number of Cavities	Location	Connects to	Notes
C741	10	Passenger's door	Main wire harness (C406)	
C742	6	Passenger's door	Main wire harness (C405)	
C743	2	Passenger's door	Passenger's door speaker	
C744	2	Passenger's door	Passenger's power window motor	
C745	6	Passenger's door	Passenger's door lock actuator	
C746	5	Passenger's door	Passenger's power window switch	
C747	3	Passenger's door	Passenger's door lock switch	
C748	3	Passenger's door	Passenger's power mirror actuator	USA
C748	6	Passenger's door	Passenger's power mirror actuator	Canada

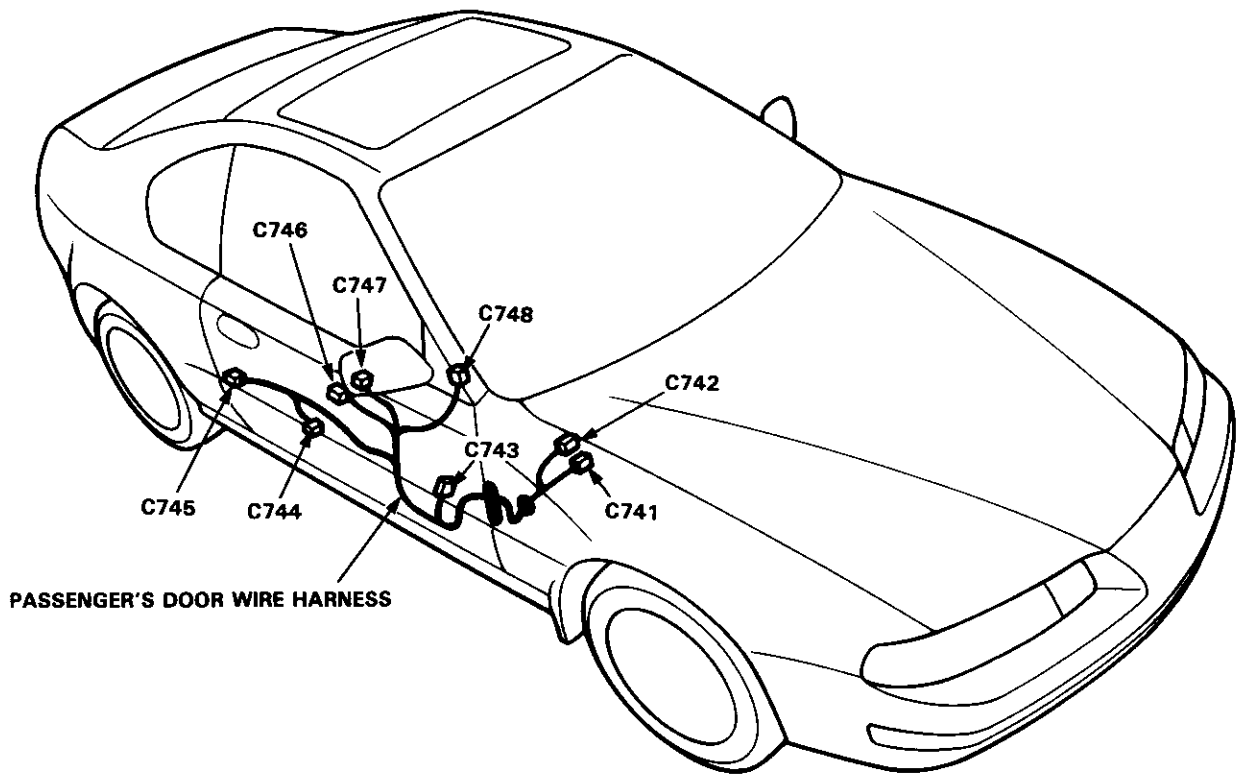
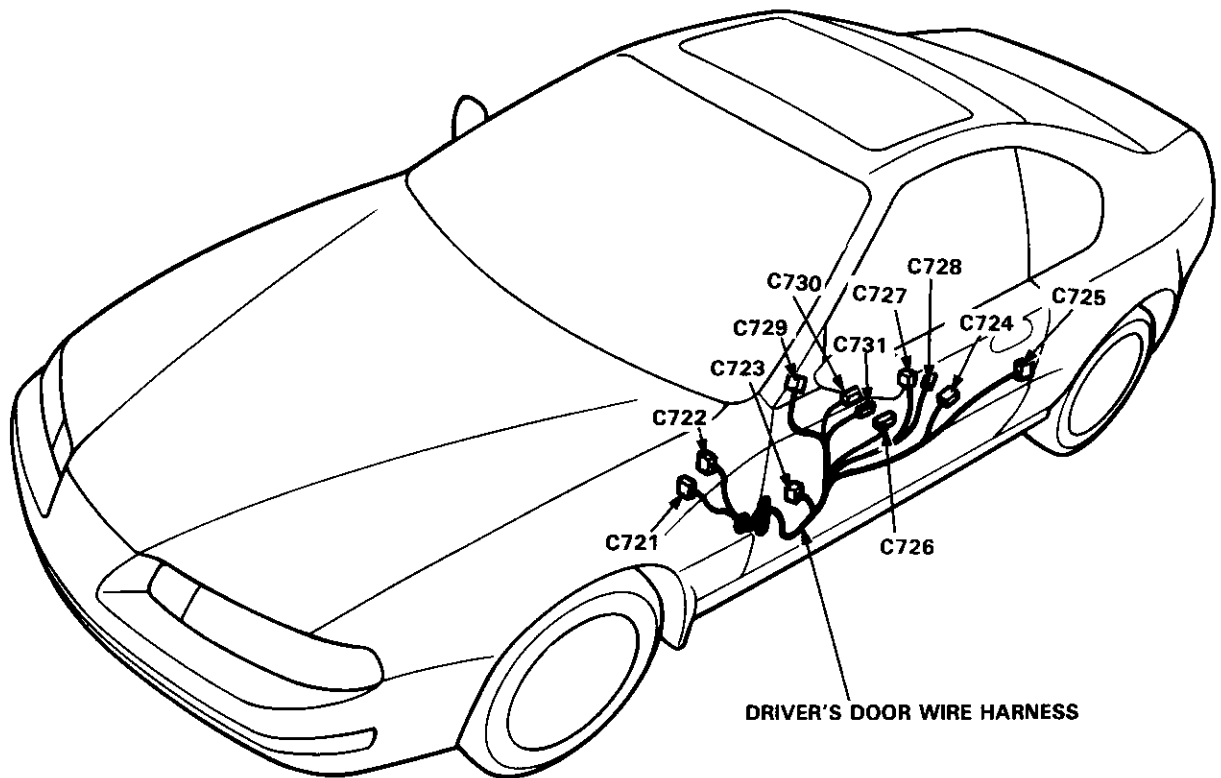

Fuses

Under-hood Fuse/Relay Box

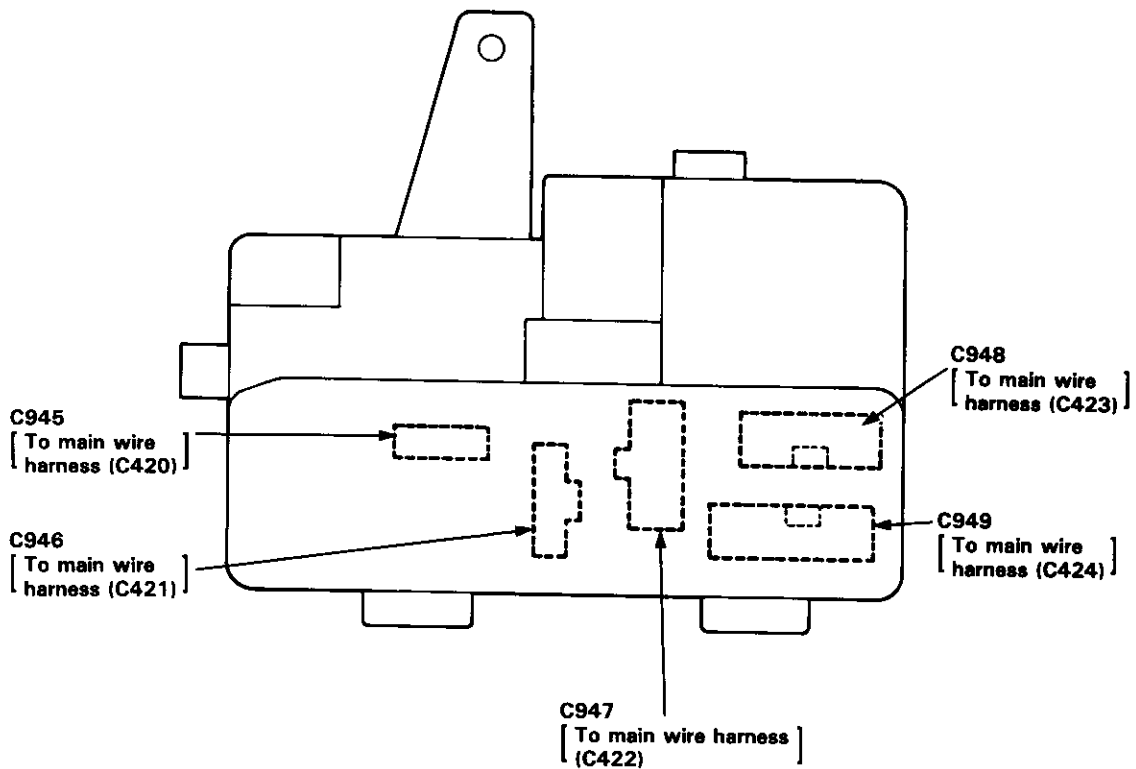
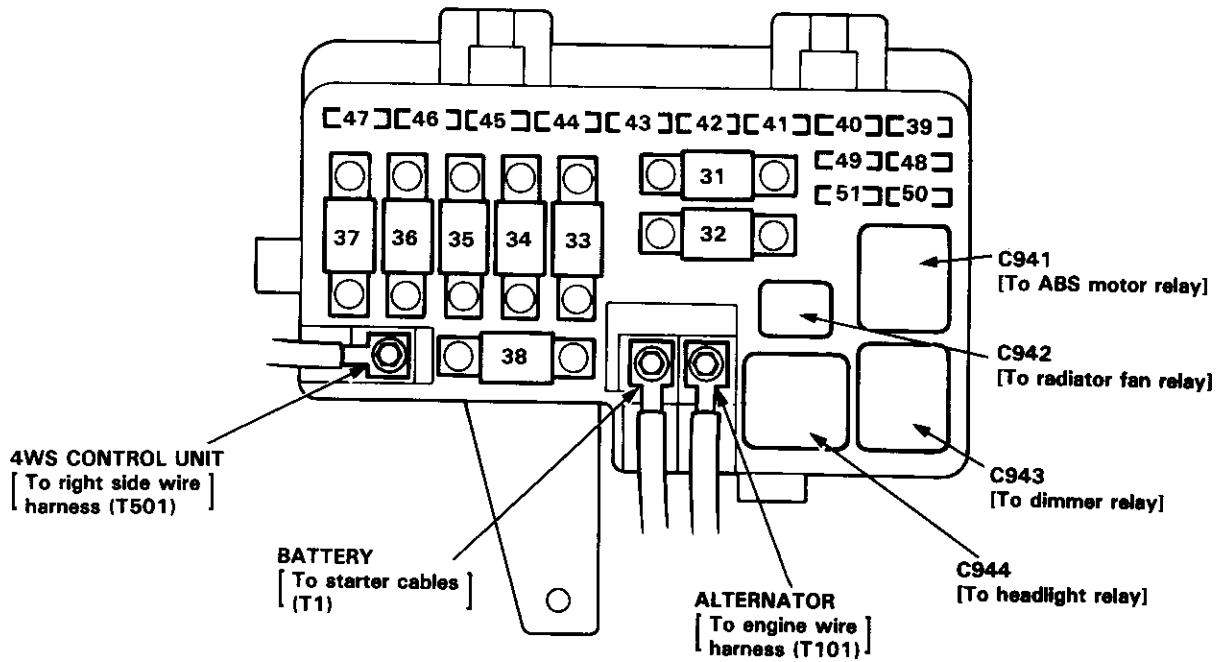



Fuse Number	Amps	Wire Color	Circuits and Components Protected
-------------	------	------------	-----------------------------------

31	50 A	—	ABS motor relay
32	100 A	—	Power distribution
33	50 A	WHT	Ignition switch (BAT)
34	40 A	BLK/GRN	Rear window defogger relay
35	40 A	WHT	Blower motor relay
36	40 A	WHT/RED	Seat heaters (Canada), PGM-FI main relay
37	40 A	WHT/BLU	Sunroof system, power window system, daytime running lights control unit (Canada)
38	60 A	WHT	4WS control unit
39	15 A	WHT/YEL	Turn signal/hazard relay, hazard warning lights
40	15 A	WHT	ABS control unit (B2)
41	15 A	WHT/YEL	Horns, horn relay, brake lights, brake light signal
42	20 A	RED/GRN	Parking lights, dash lights
43	10 A	WHT/YEL	Clock (+ B), stereo sound system, 4WS control unit, ECM, transmission control module (TCM)
44	15 A	WHT	Power door lock control unit
45	15 A	WHT/GRN	Condenser fan motor, radiator fan control module
46	15 A	WHT/BLU	Ceiling light, cigarette lighter relay, trunk light, ignition key light
47	15 A	—	Radiator fan motor
48	7.5 A	WHT/BLK	ABS control unit
49	20 A	WHT/GRN	ABS control unit (B1)
50	20 A	RED/GRN	Right headlight
51	20 A	RED/YEL	Left headlight, high beam indicator light

Fuses

Under-dash Fuse/Relay Box

Front View (see page 23-50 for back view):

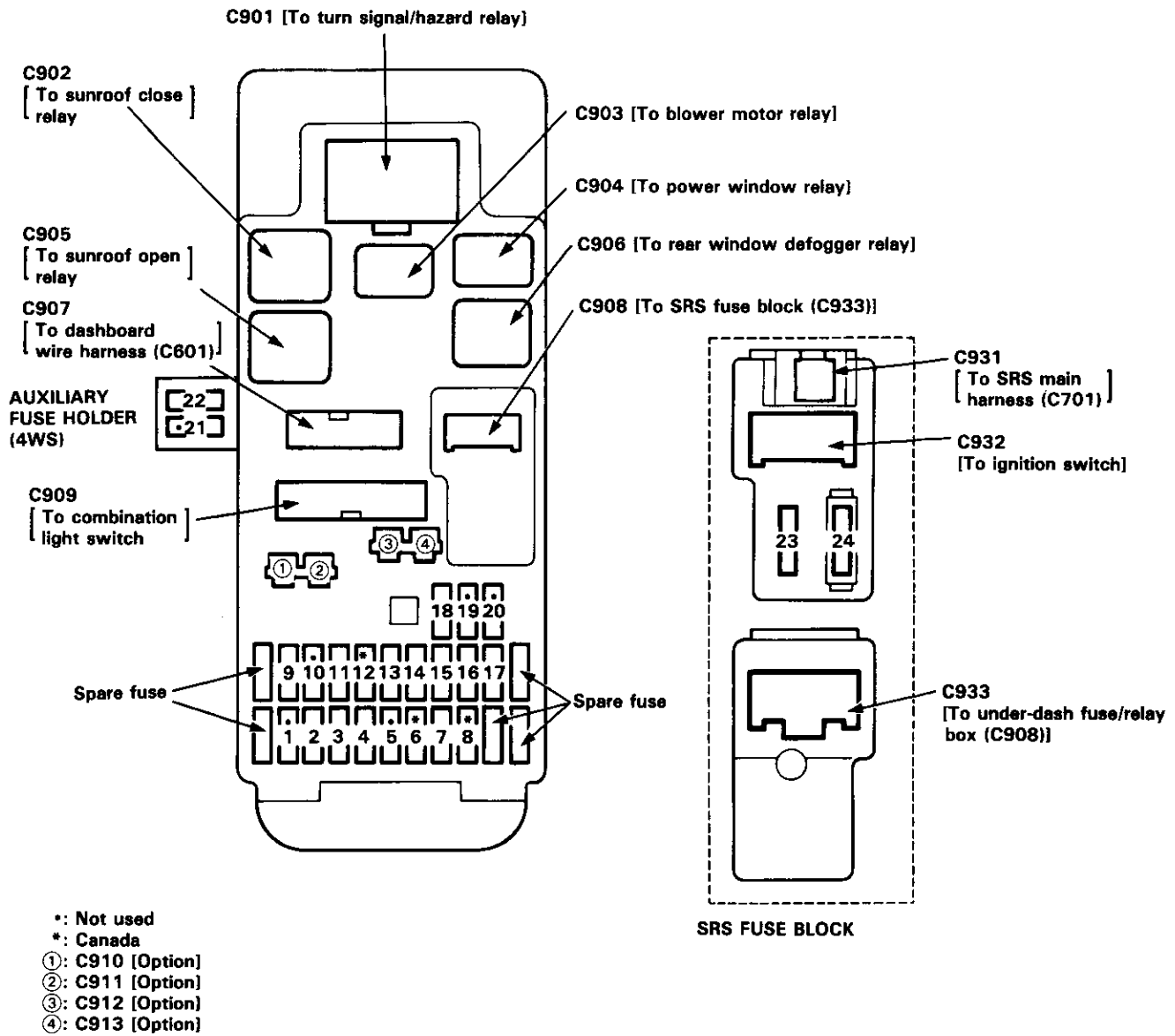



Fuse Number Amps Wire Color Circuits and Components Protected

1	—	—	Not used
2	7.5 A	BLU/RED	ECM, PGM-FI main relay, sub gauge (brake check circuit)
3	15 A	BLU/RED	Front fog lights (option)
4	10 A	YEL/BLU	PGM-FI main relay
5	—	—	Not used
6	15 A	WHT/BLK	Seat heater system (Canada)
7	30 A	Internal connection	Sunroof open relay, sunroof close relay
8	10 A	RED/GRN	Daytime running lights control unit (Canada)
9	15 A	Internal connection	Option 2 connector, blower motor relay
		BLK/YEL	Heater control panel, power mirror system, ABS control unit, radiator fan control module, Mode/recirculation control motor
10	—	—	Not used
11	10 A	Internal connection	Rear window defogger relay, integrated control unit,
		YEL/BLK	Seat heater main relay (Canada), A/C compressor clutch relay, ECM
12	7.5 A	YEL/RED	Daytime running lights control unit (Canada)
13	10 A	YEL	Gauge and indicator lights, clock, back-up lights
14	7.5 A	BLK/RED	Cruise control system
15	20 A	WHT/BLK	Driver's power window system
16	20 A	BLU/BLK	Passenger's power window system
17	30 A	GRN/BLK	Windshield wiper system
18	10 A	Internal connection	Option 4 connector
		YEL/RED	Stereo radio/cassette player, cigarette lighter
19	—	—	Not used
20	—	—	Not used
*21	—	—	Not used
*22	10 A	YEL/RED	4WS control unit
*23	15 A	BLK/YEL	PGM-FI main relay, transmission control module (TCM), radiator fan control module
		PNK	SRS unit
*24	10 A	RED	SRS unit

*21, 22: AUXILIARY FUSE HOLDER (With 4WS)

*23, 24: SRS FUSE BLOCK

(cont'd)

Fuses

Under-dash Fuse/Relay Box

Back View (see page 23-48 for front view):

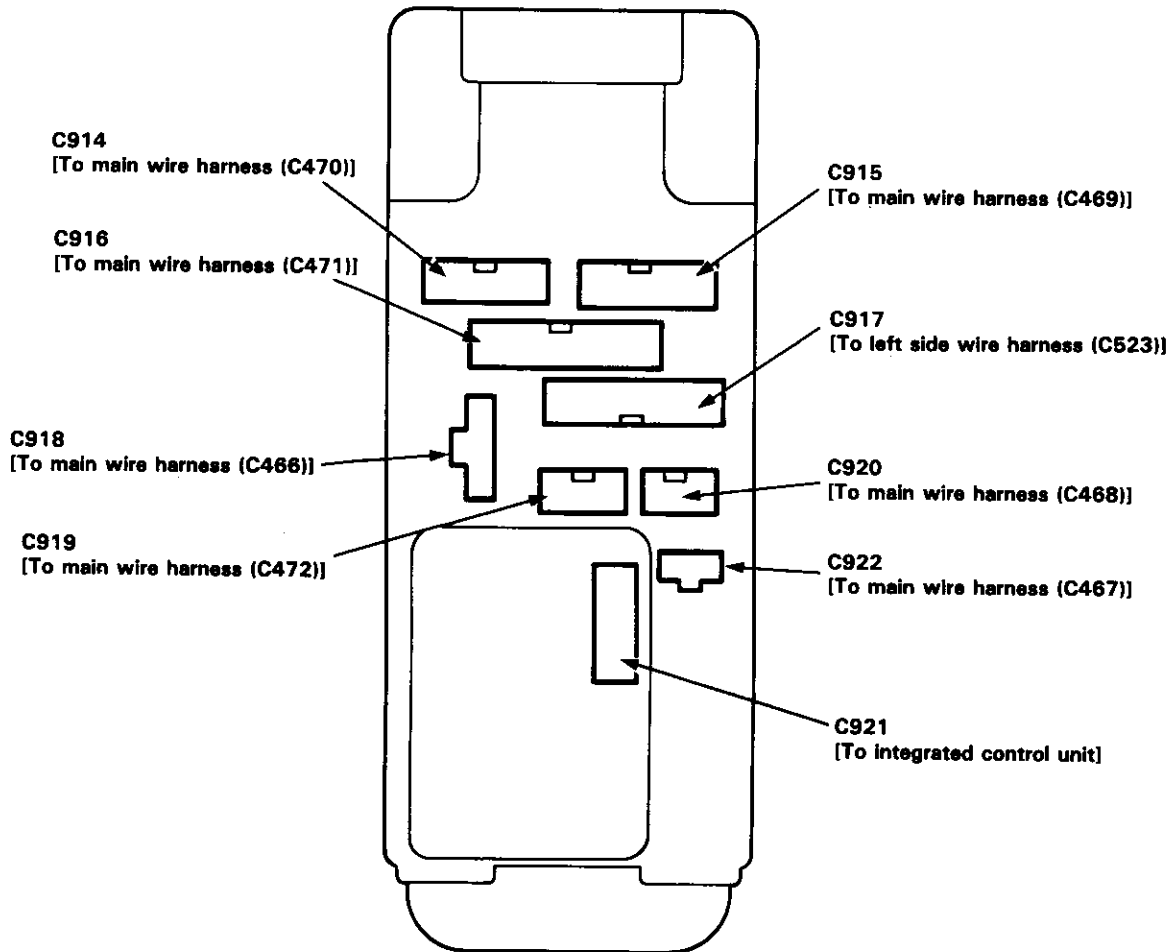

Power Distribution

Circuit Identification

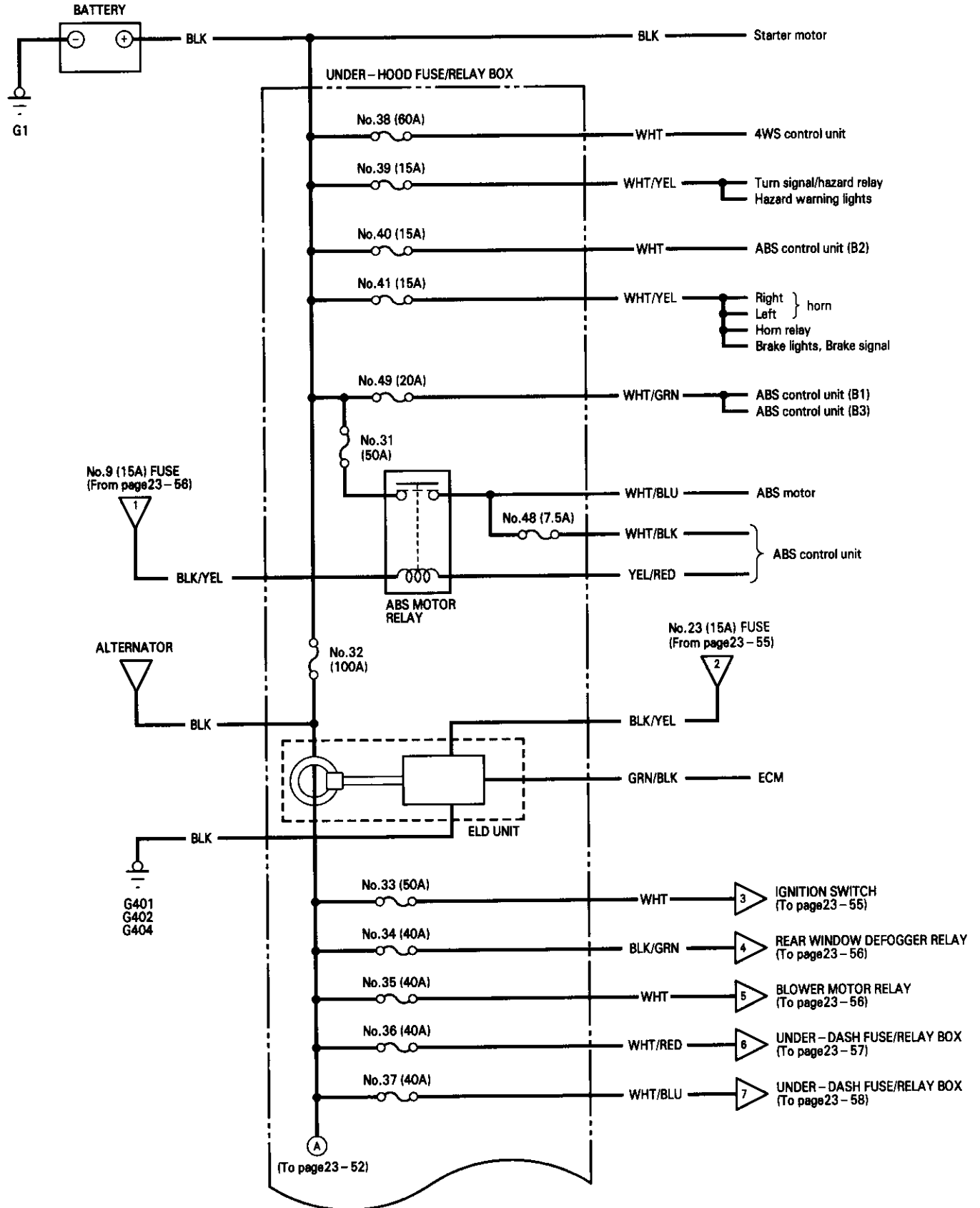

(cont'd)

Power Distribution

Circuit Identification (cont'd)

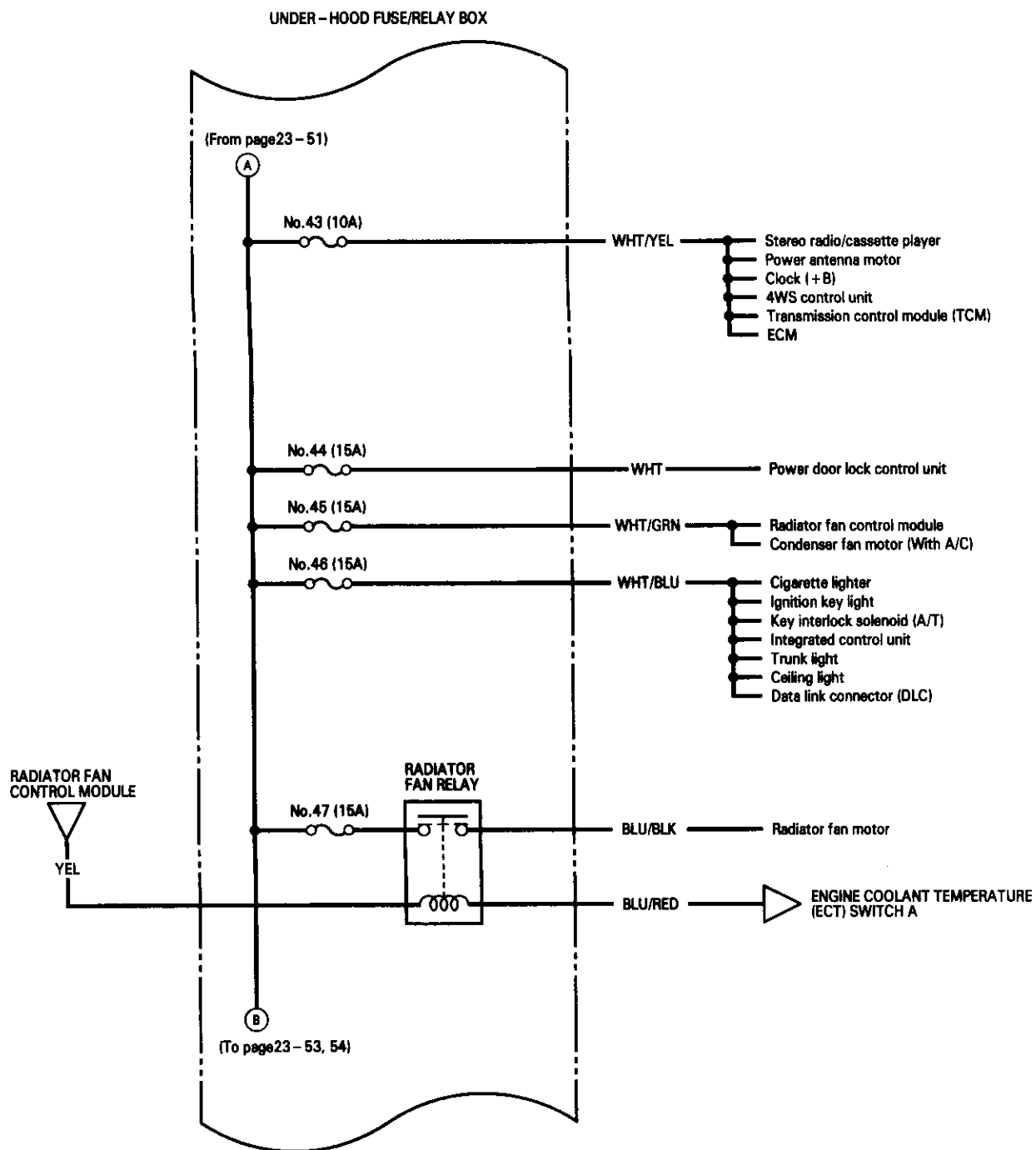



USA:

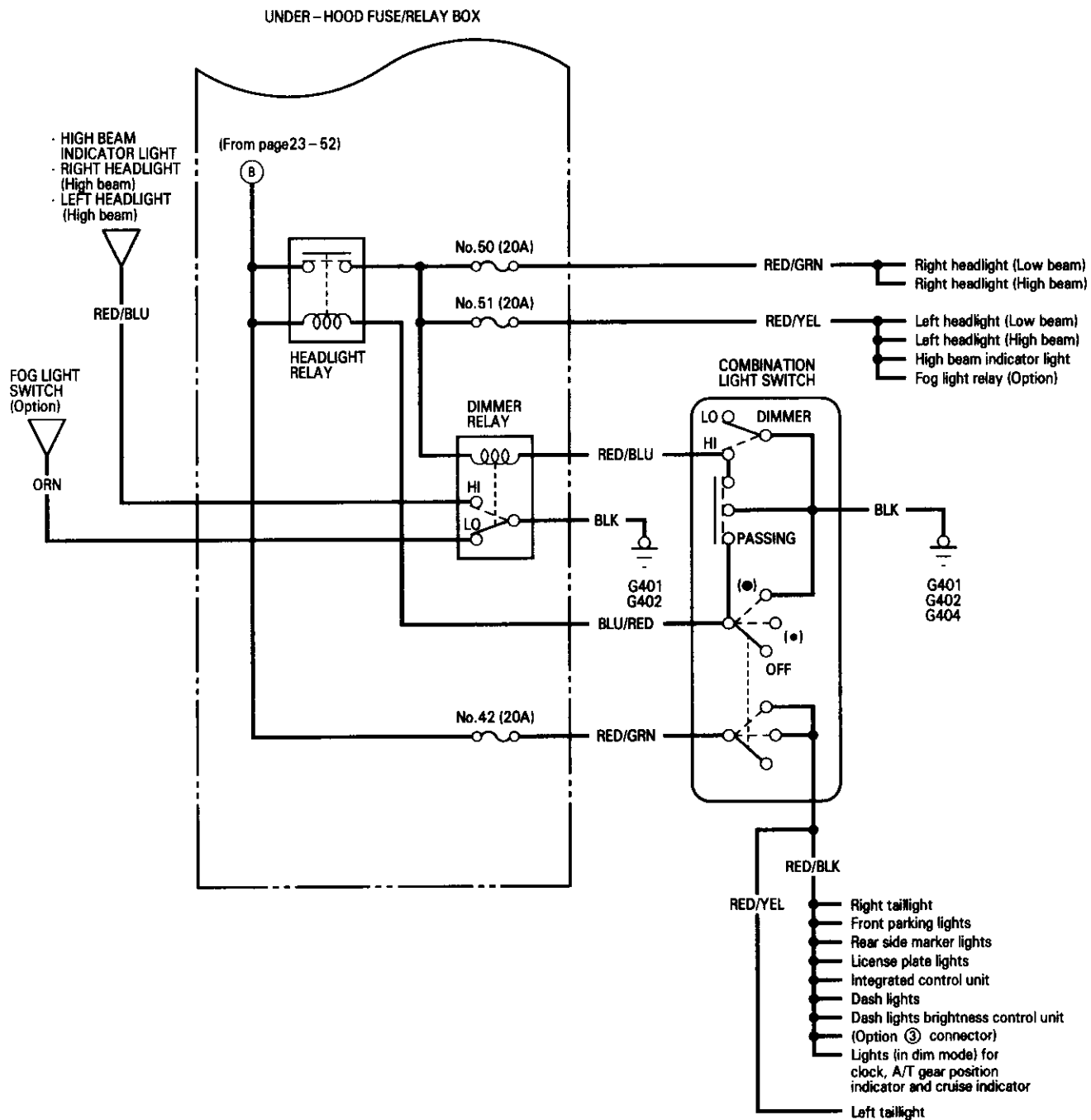

(cont'd)

Power Distribution

Circuit Identification (cont'd)

Canada:

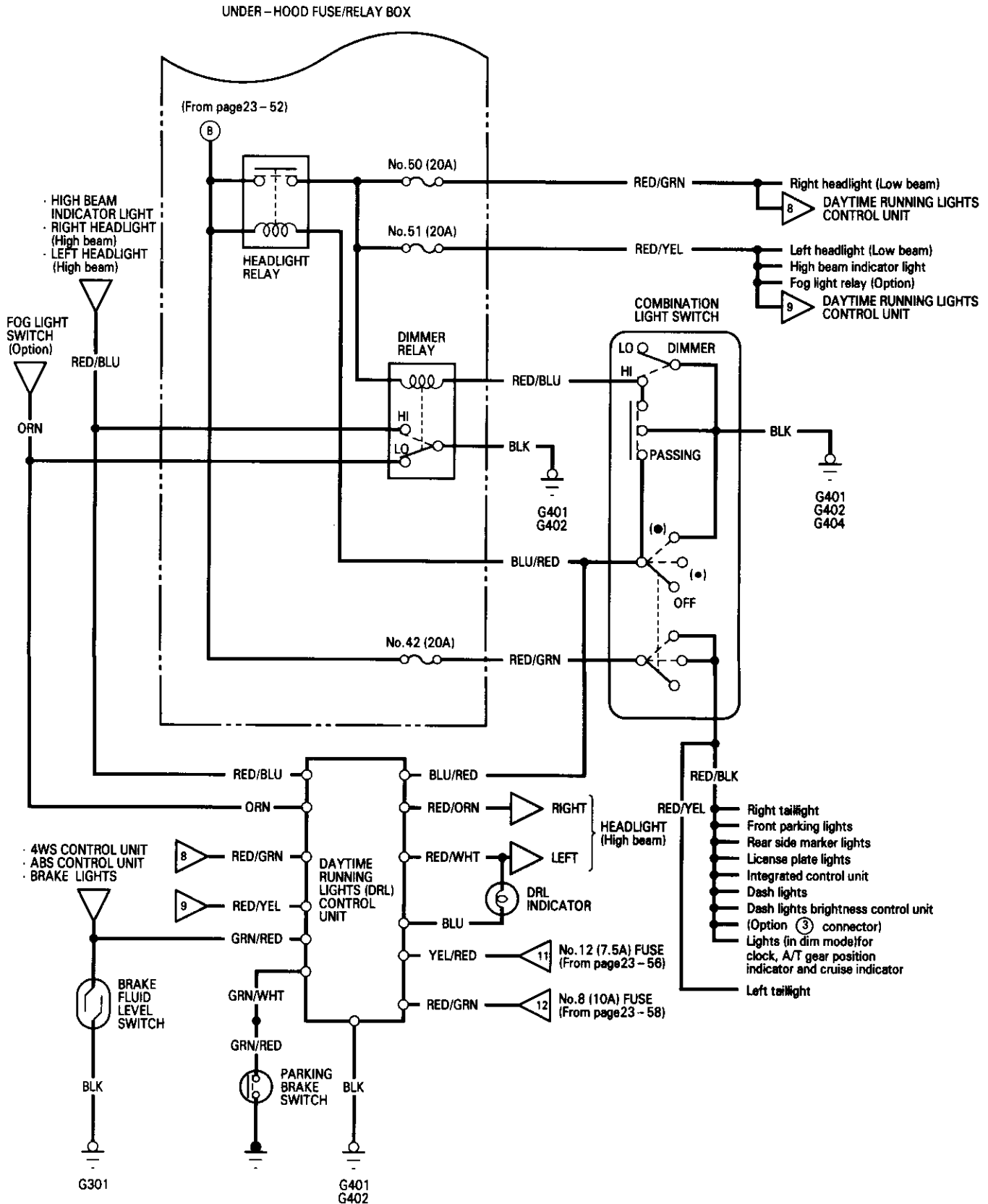



No.33 (50A) FUSE
(From page23-51)

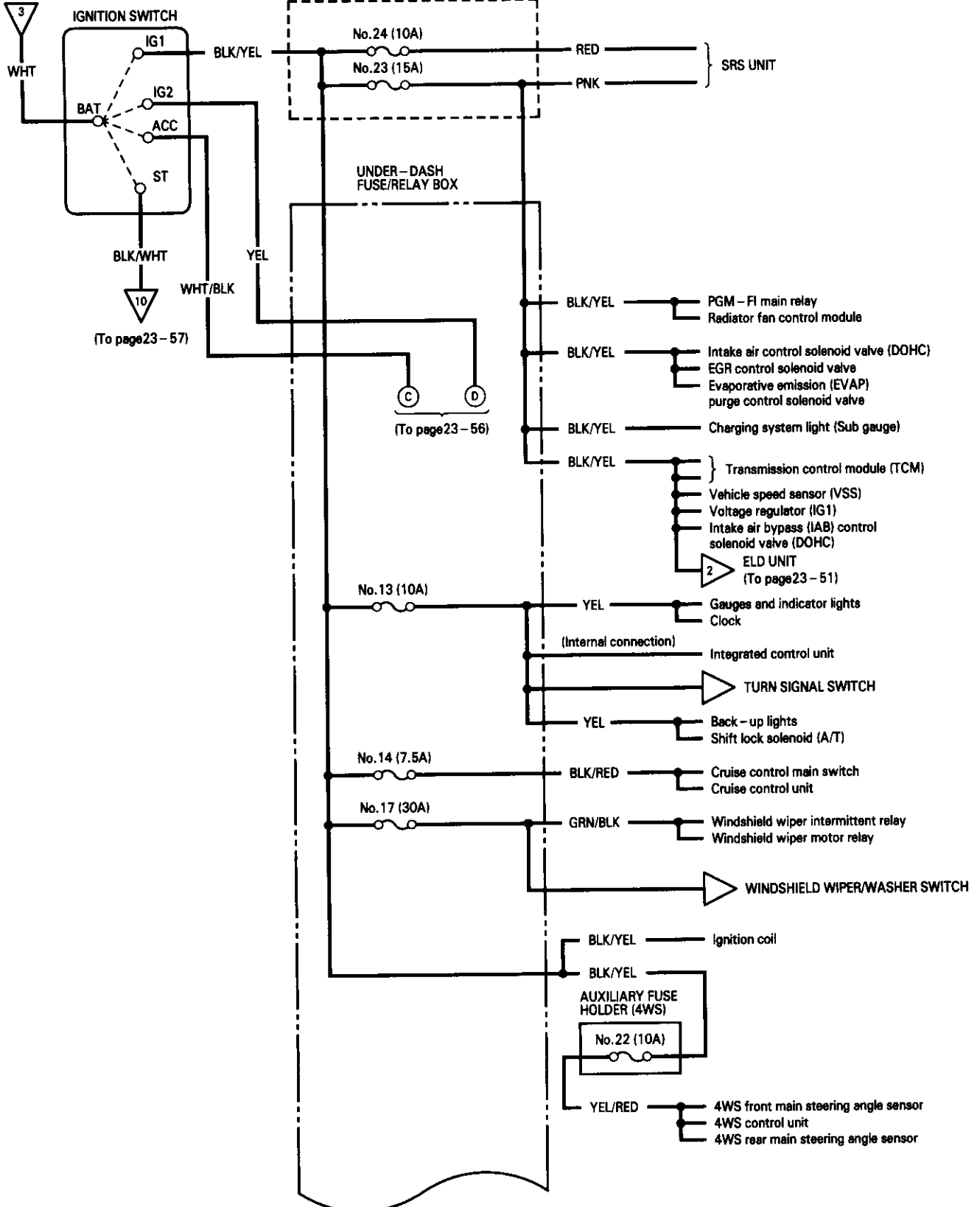

(cont'd)

Power Distribution

Circuit Identification (cont'd)

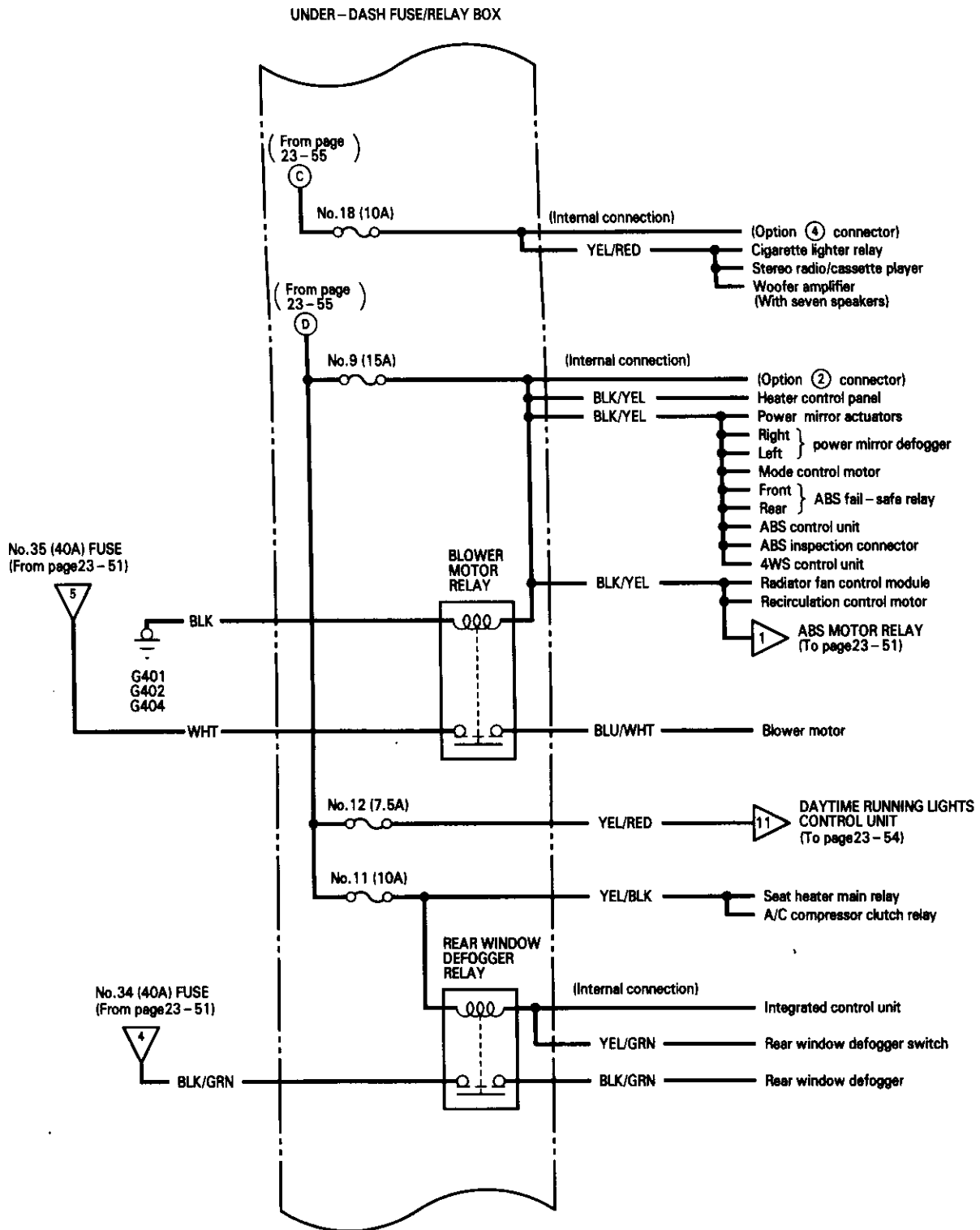

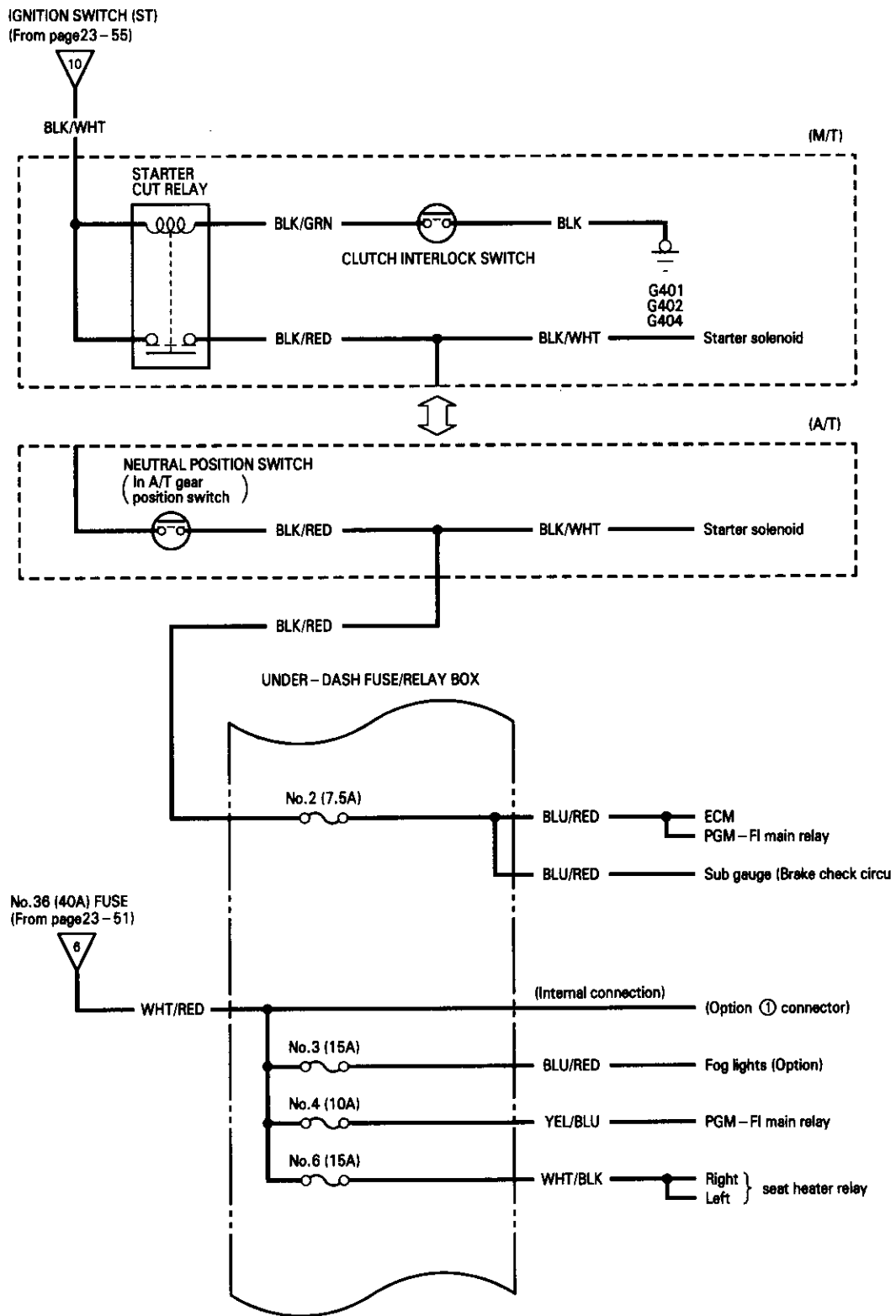

(cont'd)

Power Distribution

Circuit Identification (cont'd)

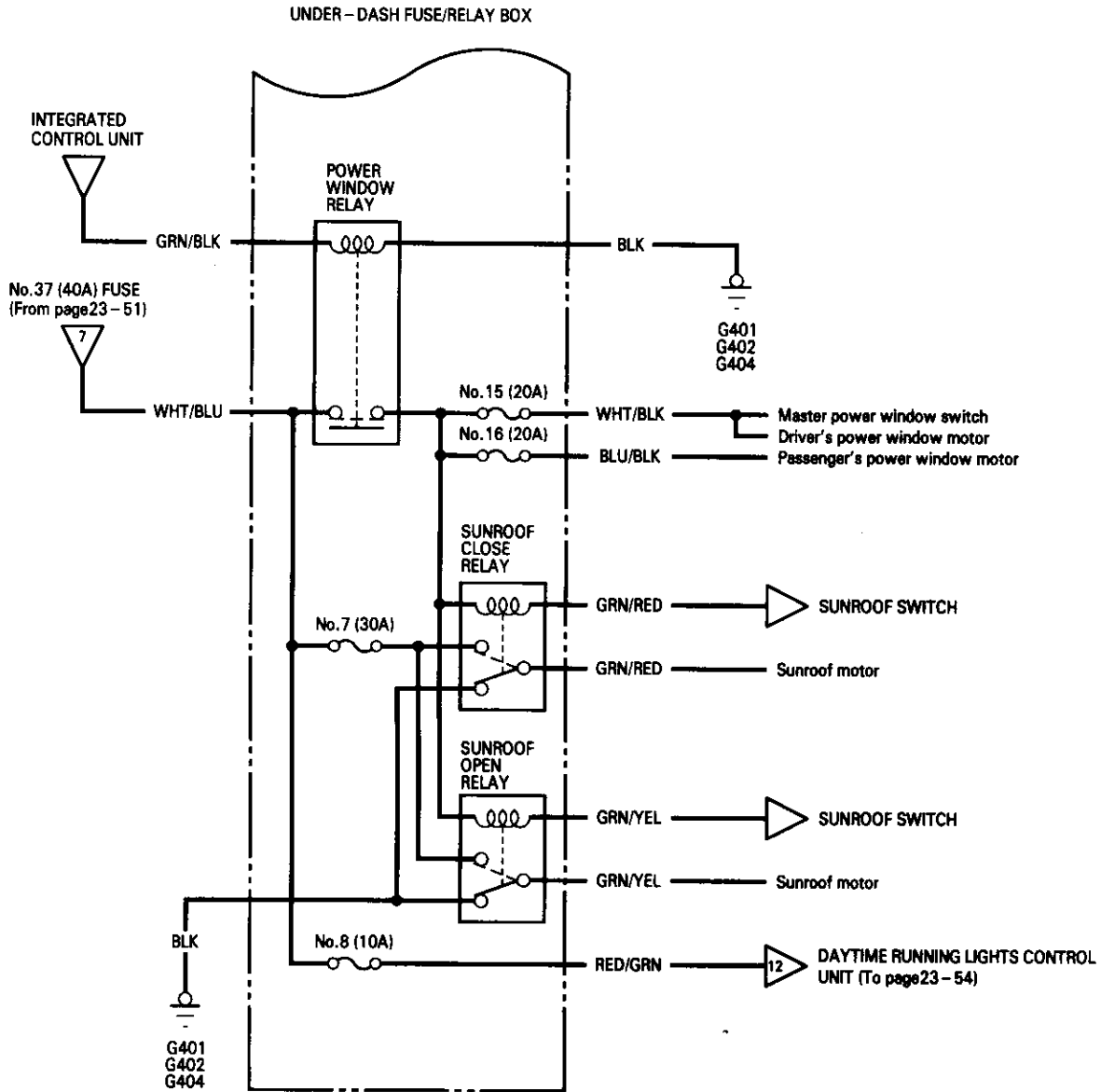

Ground Distribution

Circuit Identification

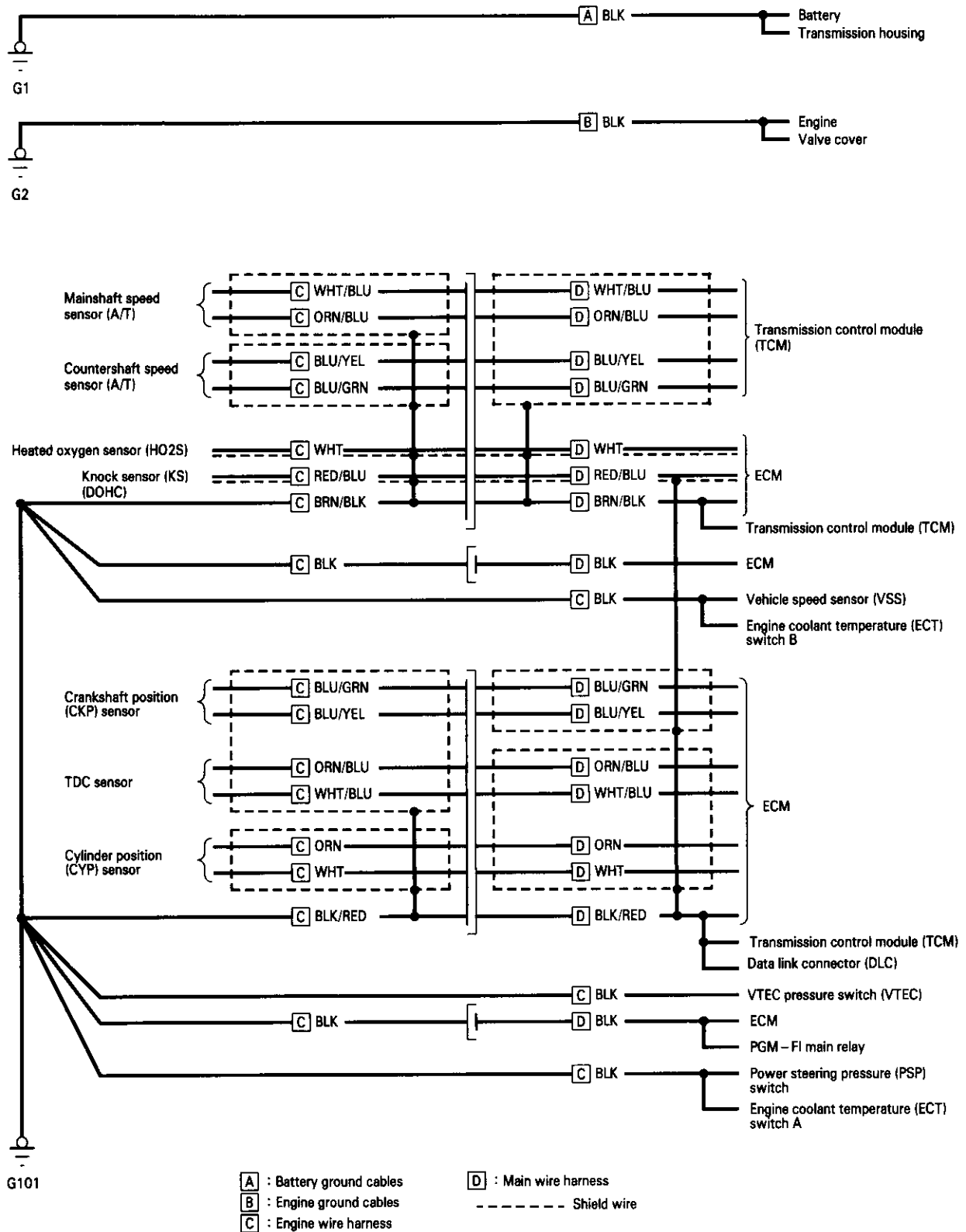

(cont'd)

Ground Distribution

Circuit Identification (cont'd)

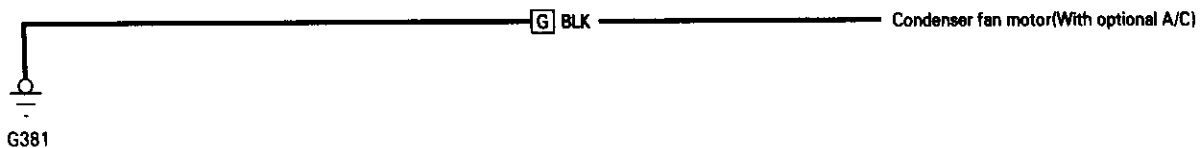
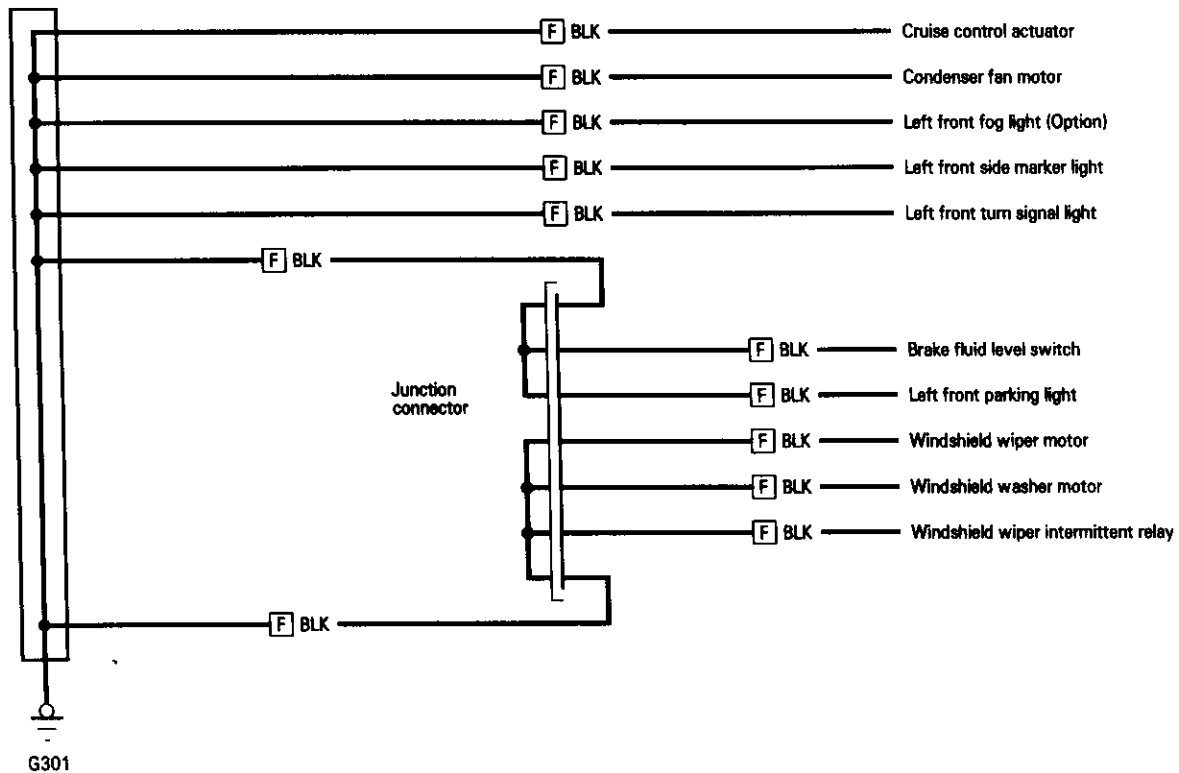
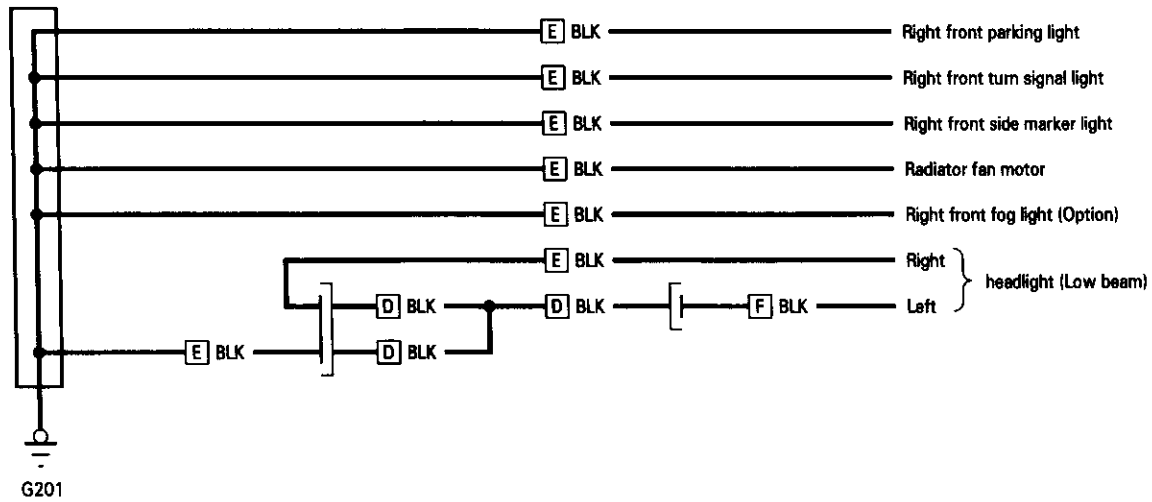

- D : Main wire harness
- E : Right engine compartment wire harness
- F : Left engine compartment wire harness
- G : A/C wire harness (With optional A/C)

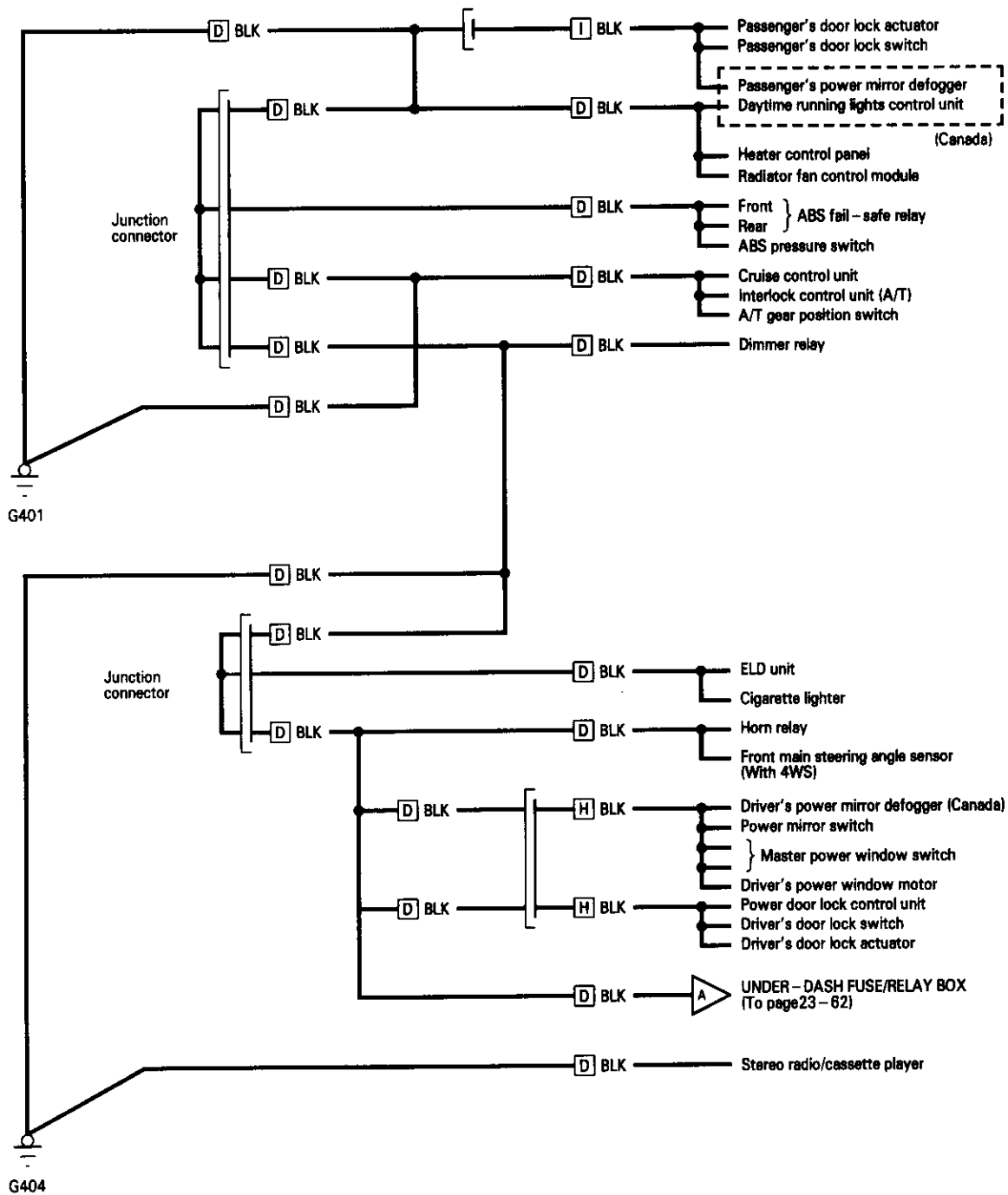

D : Main wire harness
H : Driver's door wire harness

I : Passenger's door wire harness
J : Right side wire harness

(cont'd)

Ground Distribution

Circuit Identification (cont'd)

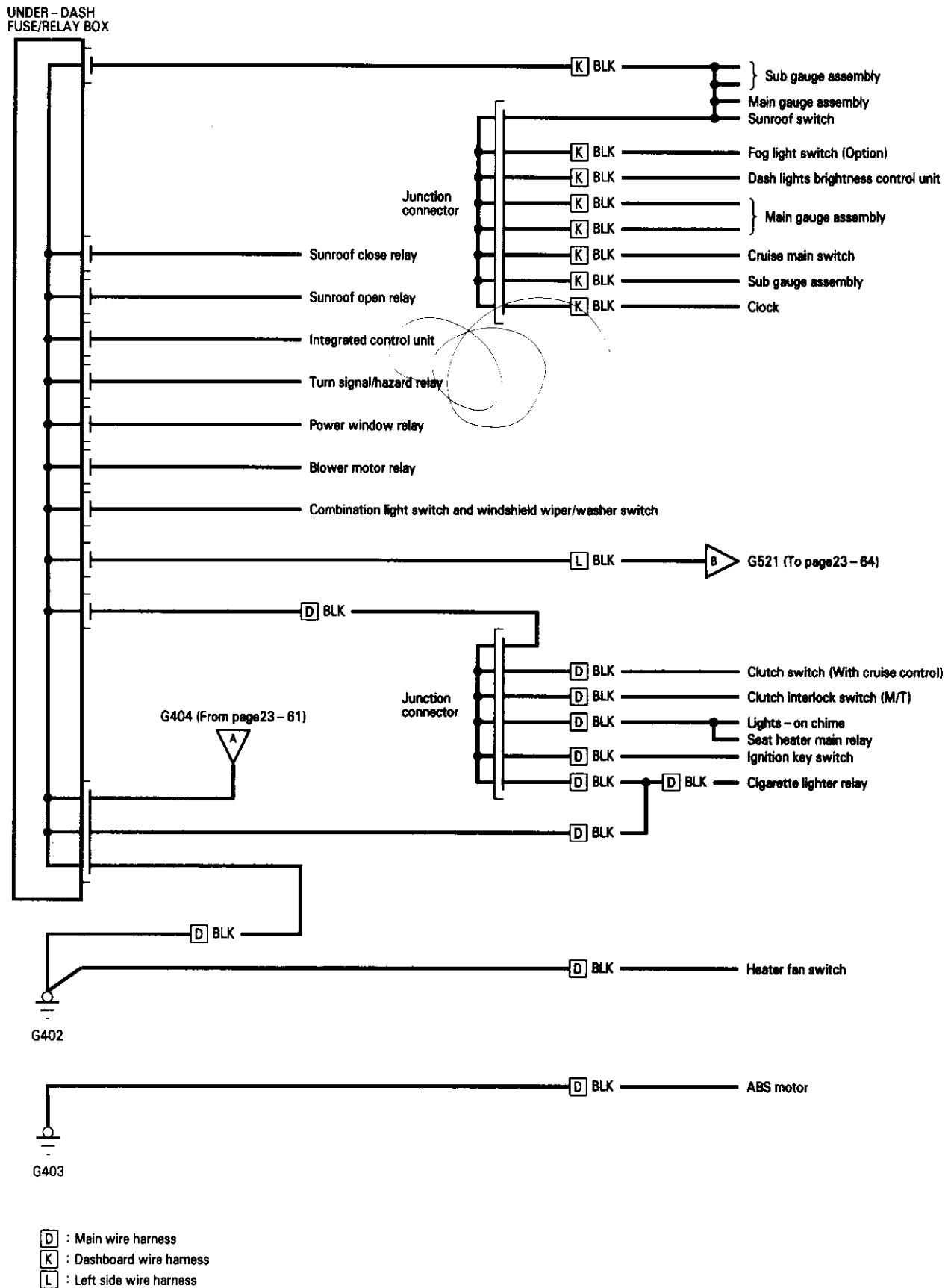

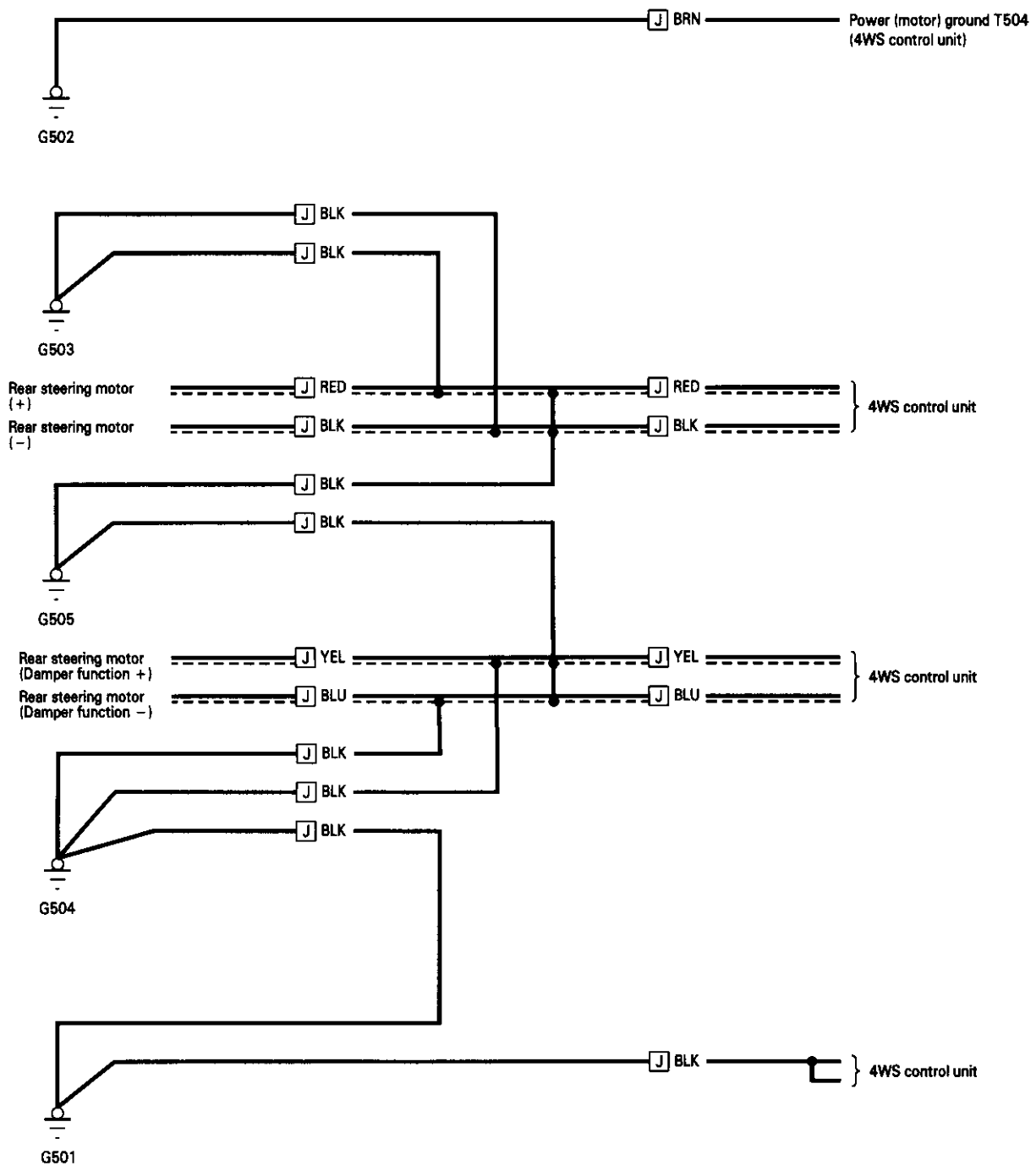

J : Right side wire harness

(cont'd)

Ground Distribution

Circuit Identification (cont'd)

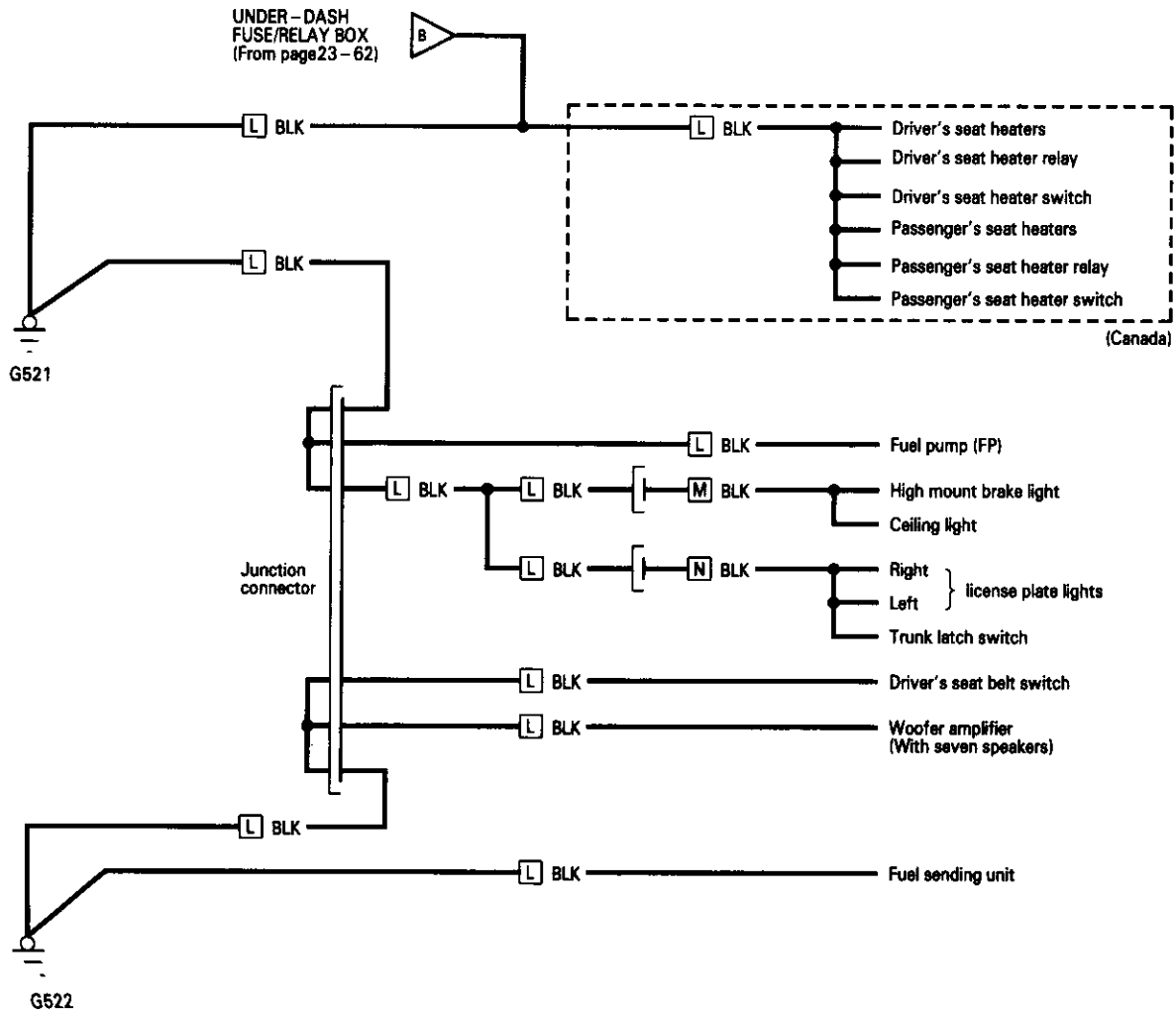

- L** : Left side wire harness
- M** : Roof wires
- N** : Rear wire harness

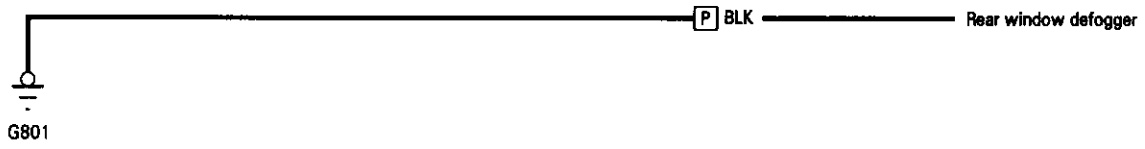
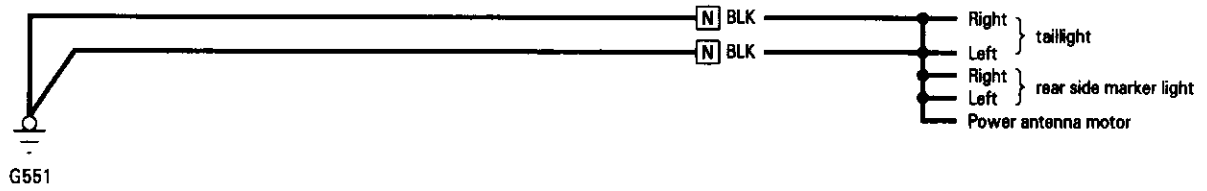

- N** : Rear wire harness
- O** : SRS main harness
- P** : Rear window defogger ground wire

Battery

Test

⚠ WARNING

- Battery fluid (electrolyte) contains sulfuric acid. It may cause severe burns if it gets on your skin or in your eyes. Wear protective clothing and a face shield.
 - If electrolyte gets on your skin or clothes, rinse it off with water immediately.
 - If electrolyte gets in your eyes, flush it out by splashing water in your eyes for at least 15 minutes; call a physician immediately.
- A battery gives off hydrogen gas. If ignited, the hydrogen will explode and could crack the battery case and splatter acid on you. Keep sparks, flames, and cigarettes away from the battery.
- Overcharging will raise the temperature of the electrolyte. This may force electrolyte to spray out of the battery vents. Follow the charger manufacturer's instructions and charge the battery at a proper rate.

Use either a JCI or Bear ARBST tester, and follow the manufacturer's procedures. If you don't have one of these computerized testers, follow this conventional test procedure:

To get accurate results, the temperature of the electrolyte must be between 70°F (21°C) and 100°F (38°C).

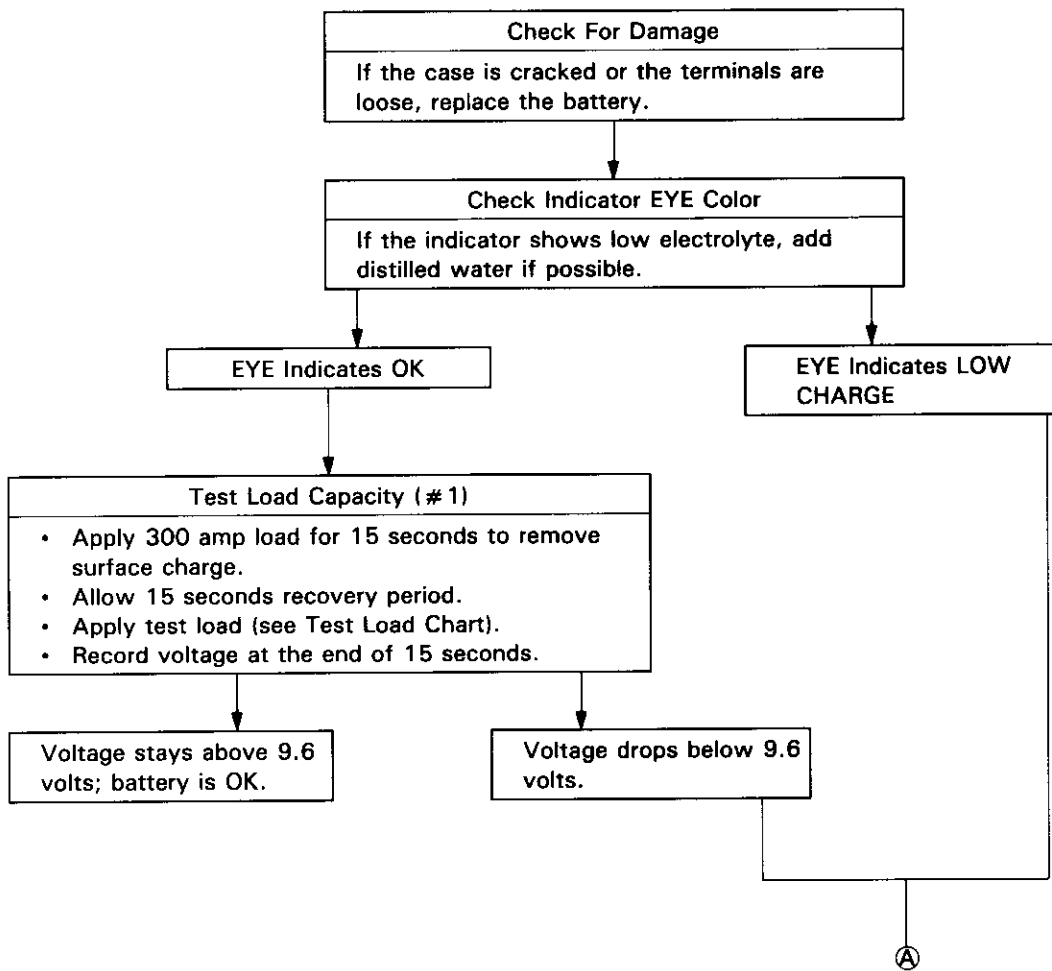



(A)

Charge on High Setting (40 amps)

Charge until EYE shows charge is OK; plus an additional 30 minutes to assure full charge.
 NOTE: If the battery charge is very low, it may be necessary to bypass the charger's polarity protection circuitry.
 If the EYE does not show charge is OK within three hours, the battery is no-good; replace it.
 Write down how long the battery was charged.

Test Load Capacity (# 2)

- Apply 300 amp load for 15 seconds to remove surface charge.
- Allow 15 seconds recovery period.
- Apply test load (see Test Load Chart).
- Record voltage at the end of 15 seconds.

Voltage stays above 9.6 volts; battery is OK.

Voltage drops below 9.6 volts; battery is no-good.

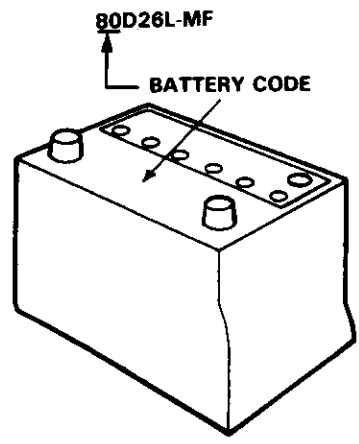

TEST LOAD CHART		
Use the test load of 1/2 the cold cranking amps (CCA) printed on the label on the top of the battery. If neither is indicated, use the information below:		
BATTERY CODE	COLD CRANKING AMPS (CCA)	LOAD (amps)
80	550	270
70	440	220
55	405	200

Under-dash Fuse/Relay Box

Removal/Installation

CAUTION:

- All SRS electrical wiring harnesses are covered with yellow outer insulation.
- Before disconnecting the SRS wire harness, install the short connector(s) on the airbag(s) (see page 23-294).
- Replace the entire affected SRS harness assembly if it has an open circuit or damaged wiring.

NOTE: The radio may have a coded theft protection circuit. Be sure to get the customer's code number before

- Disconnecting the battery.
- Removing the No. 43 (10 A) fuse.
(In the under-hood fuse/relay box)
- Removing the radio.

After service, reconnect power to the radio and turn it on. When the word "CODE" is displayed, enter the customer's 5-digit code to restore radio operation.

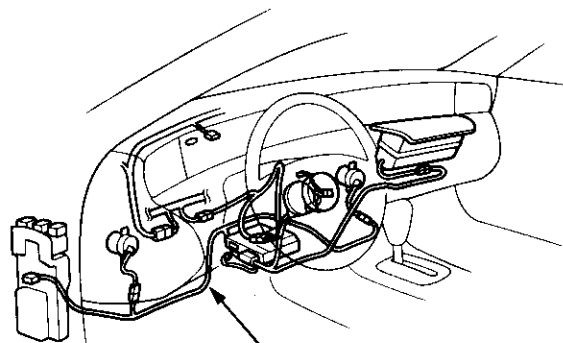

SRS MAIN HARNESS

Removal:

1. Disconnect both the negative cable and positive cable from the battery.
2. Remove the driver's foot rest.

3. Remove the dashboard lower cover, knee bolster, and heater duct.

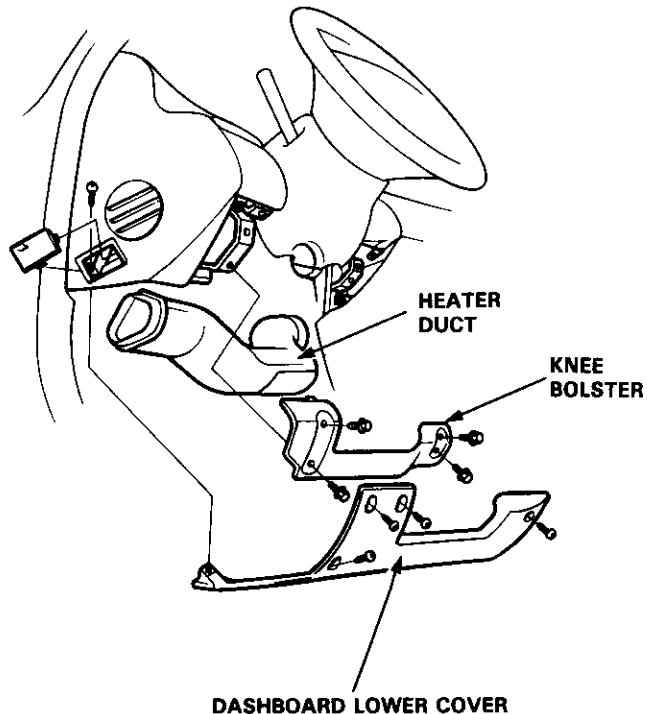

DASHBOARD LOWER COVER

4. Remove the door sill molding and left kick panel.

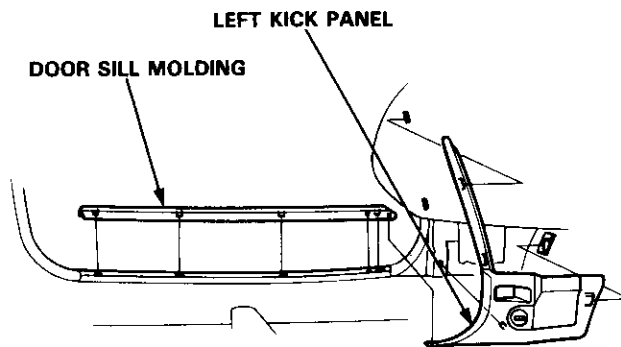

LEFT KICK PANEL

DOOR SILL MOLDING



5. Disconnect the 16-P connector from the integrated control unit.
6. Remove the mounting bolts and pull the fuse/relay box away from the kick panel.

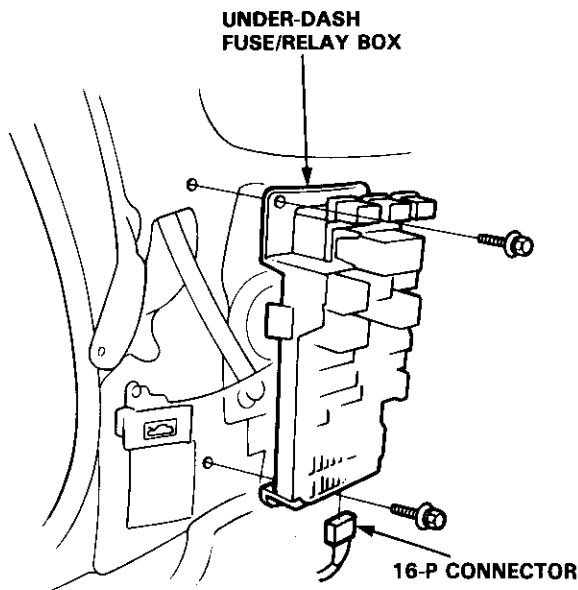

Disconnect the fuse/relay box connectors and take out the fuse/relay box.

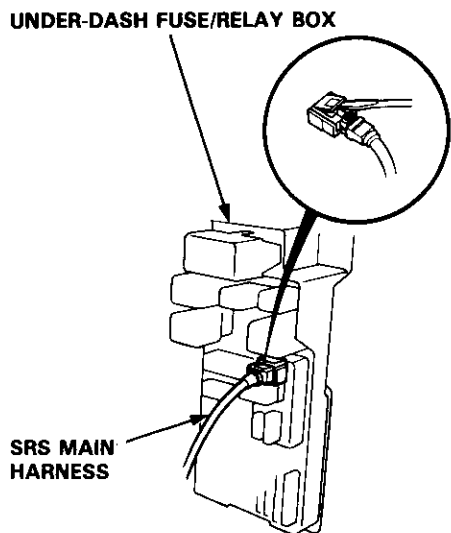

NOTE: The SRS main harness connector is double-locked. To remove it, first lift the connector lid, then press the connector tab down and pull the connector out.

Installation:

1. Reconnect the connectors to the fuse/relay box.

NOTE: To reinstall the SRS main harness connector, push it into position until it clicks, then close the connector lid.

2. Install the under-dash fuse/relay box.
3. Reinstall the kick panel and door sill molding.
4. Reinstall the knee bolster and dashboard lower cover.
5. Connect both the negative cable and positive cable to the battery.
6. Confirm that all systems work properly.

Power Relays

Relay Test (A-type)

NOTE: See page 23-198 for the turn signal/hazard relay input test and see page 23-236 for the seat heater relay test.

1. Remove the power relay from its socket.
 2. Check continuity between relay terminals.
- There should be continuity between the C and D terminals.
 - There should be continuity between the A and B terminals when power and ground are connected to the C and D terminals. There should be no continuity when power is disconnected.

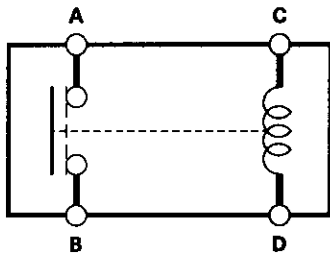

- Starter cut relay
- Horn relay
- Cigarette lighter relay
- Power window relay
- Blower motor relay
- Radiator fan relay

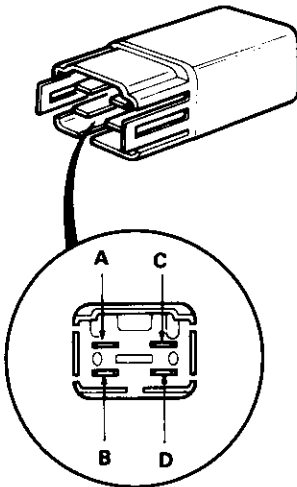

- Seat heater main relay
- ABS front fail-safe relay
- ABS rear fail-safe relay

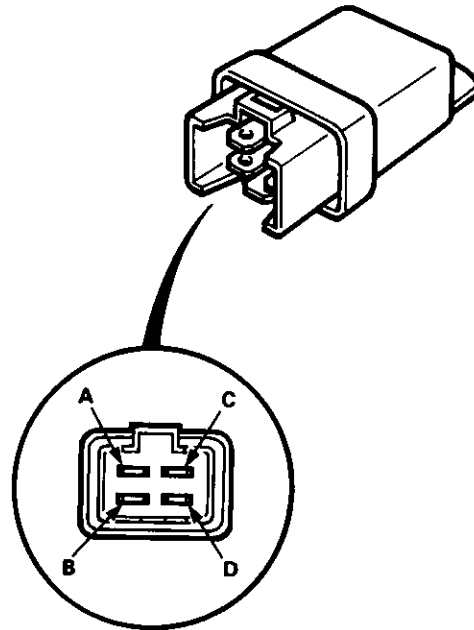

- Condenser fan relay
- A/C compressor clutch relay

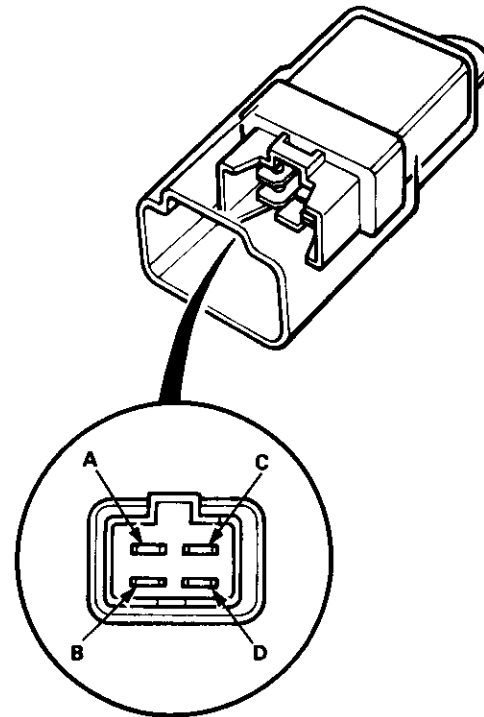



- Headlight relay
- Rear window defogger relay
- ABS motor relay

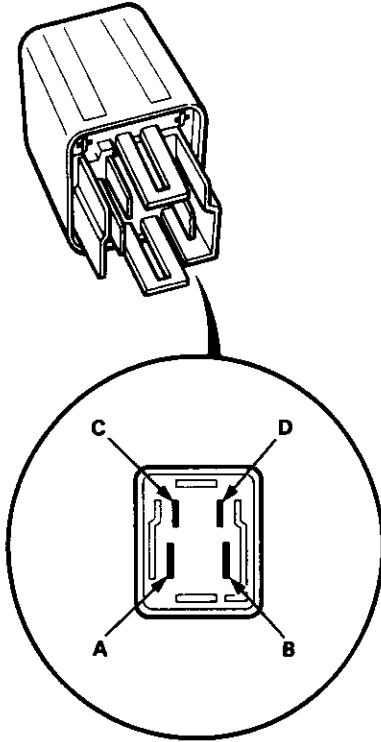

Power Relays

Relay Test (B-type)

1. Remove the power relay from its socket.
2. Check continuity between relay terminals.

- There should be continuity between the A and C terminals when power and ground are connected to the D and E terminals.
- There should be continuity between the B and C terminals when power is disconnected.

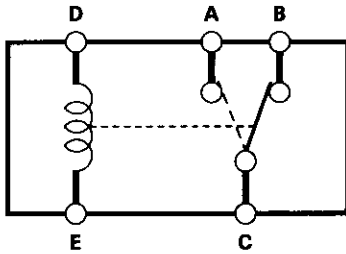

- Dimmer relay

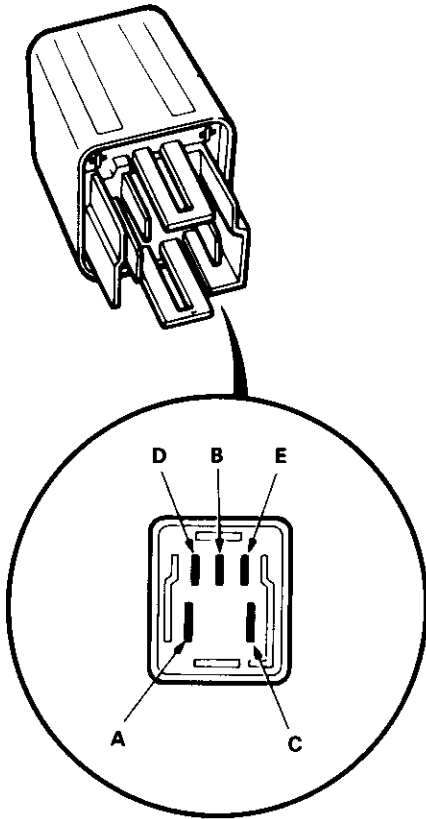

- Windshield wiper intermittent relay

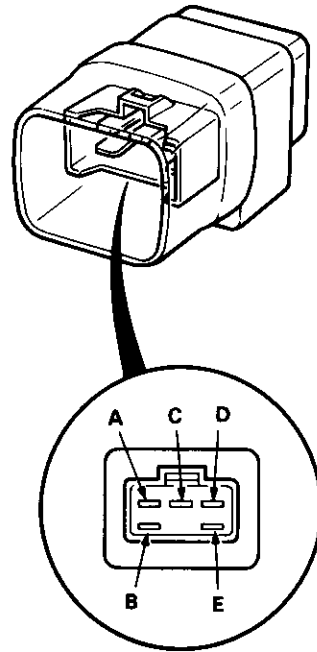

- Sunroof open relay
- Sunroof close relay

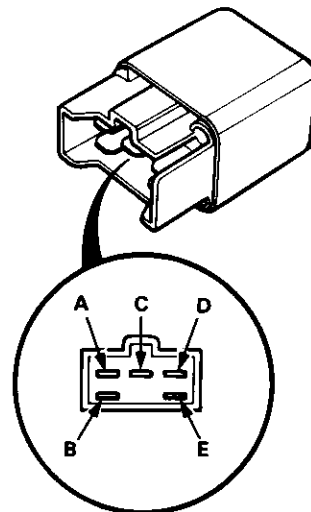

Ignition Switch



Test

CAUTION:

- All SRS electrical wiring harnesses are covered with yellow outer insulation.
- Before disconnecting the SRS wire harness, install the short connector(s) on the airbag(s) (see page 23-294).
- Replace the entire affected SRS harness assembly if it has an open circuit or damaged wiring.

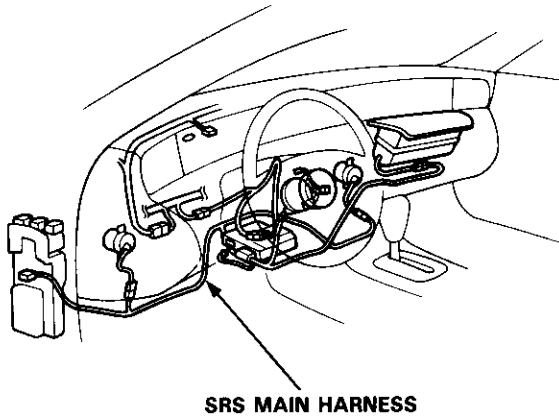

1. Remove the dashboard lower cover, left knee bolster, and left kick panel (see page 23-68).
2. Disconnect the 5-P connector from the under-dash fuse/relay box and disconnect the 3-P connector from the main wire harness.

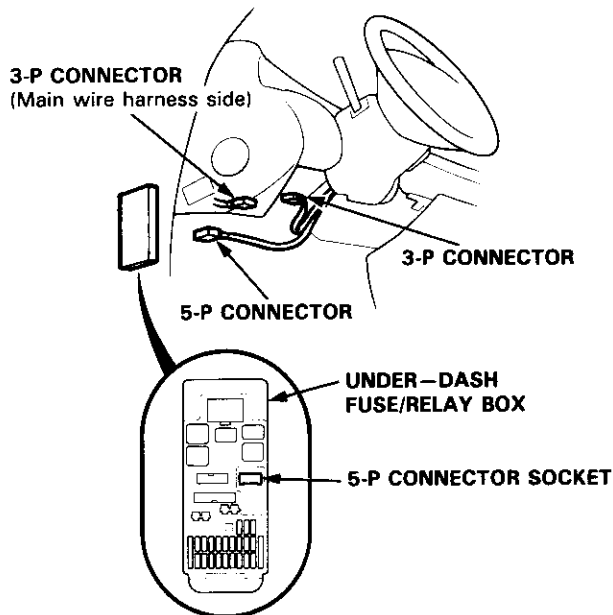

3. Check for continuity between the terminals in each switch position according to the table.

Terminal Position	WHT/BLK (ACC)	WHT (BAT)	BLK/YEL (IG1)	YEL (IG2)	BLU/WHT (ST)
0					
I	○—○				
II	○—○	○—○	○—○	○—○	
III		○—○	○—○		○—○

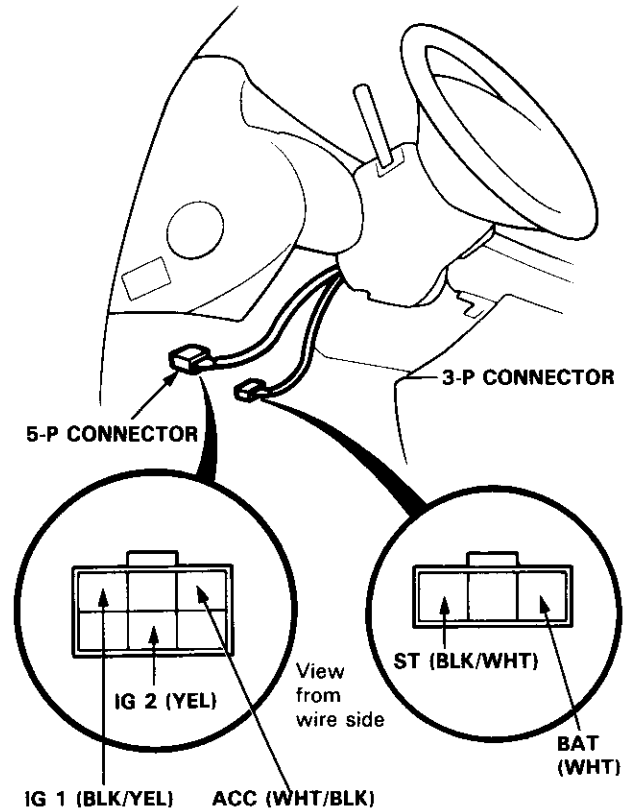

Ignition Switch

Electrical Switch Replacement

CAUTION:

- All SRS electrical wiring harnesses are covered with yellow outer insulation.
- Before disconnecting the SRS wire harness, install the short connector on the airbag(s) (see page 23-294).
- Replace the entire affected SRS harness assembly if it has an open circuit or damaged wiring.

NOTE: The radio may have a coded theft protection circuit. Be sure to get the customer's code number before

- Disconnecting the battery.
- Removing the No. 43 (10 A) fuse. (In the under-hood fuse/relay box)
- Removing the radio.

After service, reconnect power to the radio and turn it on. When the word "CODE" is displayed, enter the customer's 5-digit code to restore radio operation.

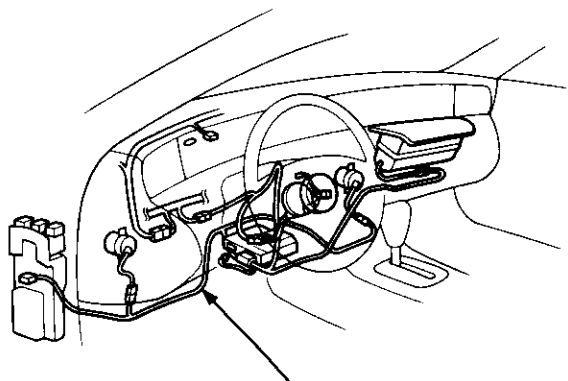

SRS MAIN HARNESS

1. Remove the dashboard lower cover and left knee bolster.
2. Remove the steering column covers.

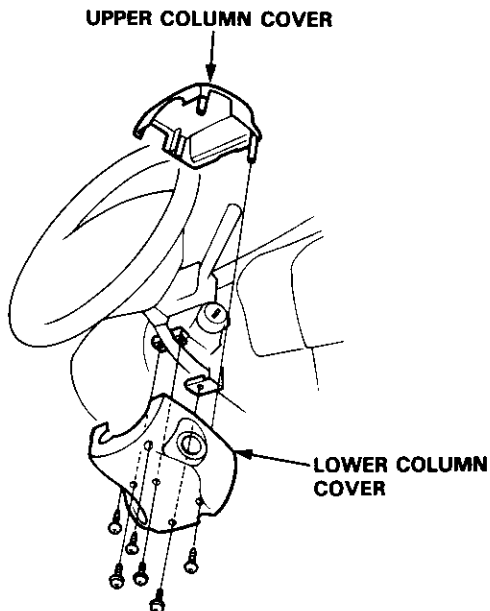

UPPER COLUMN COVER

LOWER COLUMN COVER

3. Disconnect the 5-P connector from the under-dash fuse/relay box and disconnect the 3-P connector from the main wire harness.

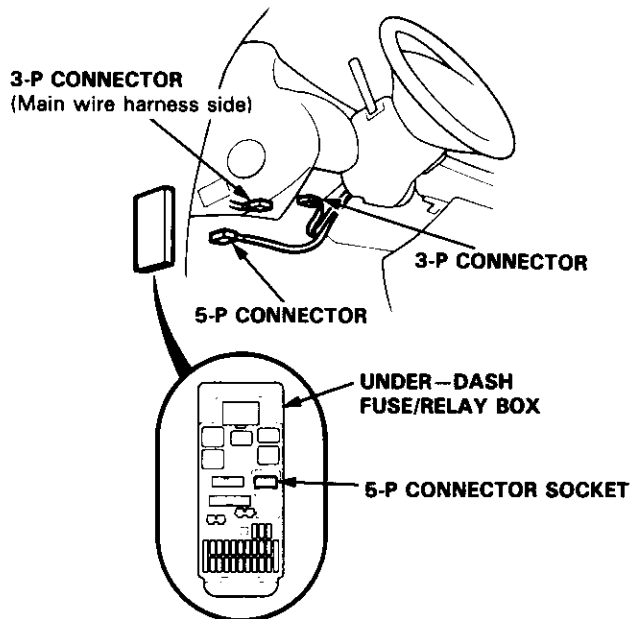

4. Insert the key and turn it to "O".
5. Remove the cover screw and the cover.
6. Remove the two mounting screws and replace the switch.

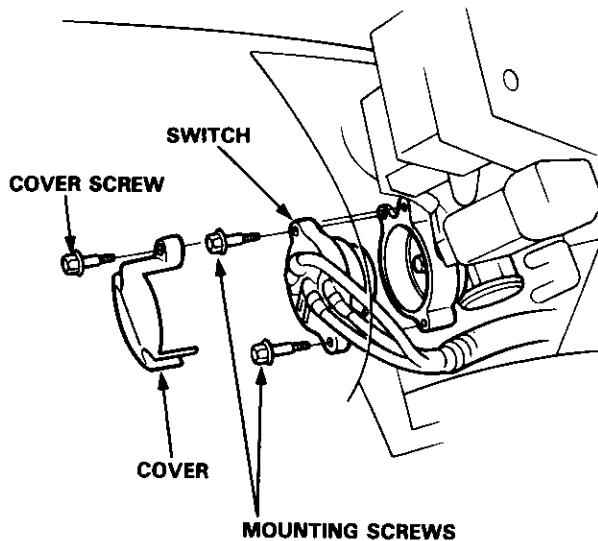



Steering Lock Replacement

CAUTION:

- All SRS electrical wiring harnesses are covered with yellow outer insulation.
- Before disconnecting the SRS wire harness, install the short connector(s) on the airbag(s) (see page 23-294).
- Replace the entire affected SRS harness assembly if it has an open circuit or damaged wiring.

NOTE: The radio may have a coded theft protection circuit. Be sure to get the customer's code number before

- Disconnecting the battery.
- Removing the No. 43 (10 A) fuse.
(In the under-hood fuse/relay box)
- Removing the radio.

After service, reconnect power to the radio and turn it on. When the word "CODE" is displayed, enter the customer's 5-digit code to restore radio operation.

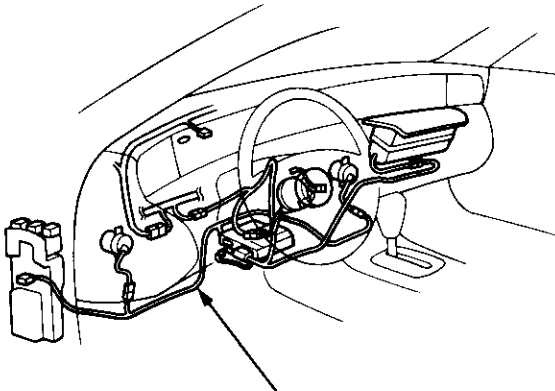

SRS MAIN HARNESS

1. Remove the dashboard lower cover, left knee bolster, and left kick panel (see page 23-68).
2. Disconnect the 5-P connector from the under-dash fuse/relay box and the 3-P connector from the main wire harness.
3. Remove the steering column covers (see page 23-74).

4. Center punch each of the two shear bolts and drill their heads off with a 5 mm (3/16 in.) drill bit.

CAUTION: Do not damage the switch body when removing the shear bolts.

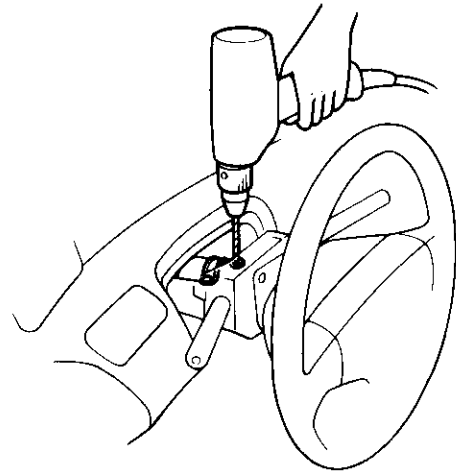

5. Remove the shear bolts from the switch body.
6. Install the new steering lock without the key inserted.
7. Loosely tighten the new shear bolts.
8. Insert the ignition key and check for proper operation of the steering wheel lock and that the ignition key turns freely.
9. Tighten the shear bolts until the hex heads twist off.

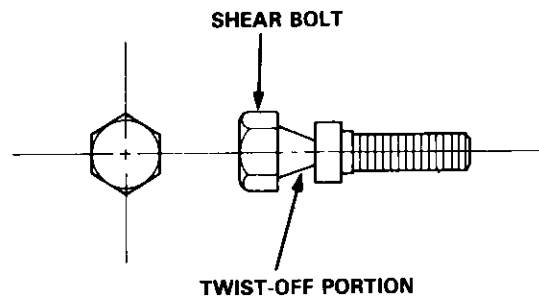

Starting System

Component Location Index

BATTERY
Test, page 23-66

**A/T GEAR POSITION SWITCH (A/T)
(and NEUTRAL POSITION SWITCH)**
Test, page 23-148
Replacement, page 23-149

CLUTCH INTERLOCK SWITCH (M/T)
Test, page 23-81
Switch Position Adjustment, section 12

STARTER
Test, page 23-79
Solenoid Test, page 23-83
Replacement, page 23-81
Overhaul, page 23-82
Reassembly, page 23-87

STARTER CUT RELAY (M/T)
Wire colors: BLK/WHT,
BLK/WHT, BLK/GRN,
and BLK/RED
Test, page 23-70



Description

Starter Interlock System (M/T):

The starter interlock system prevents the engine from starting unless the clutch pedal is fully depressed.

The clutch interlock switch turns on at the position where the clutch disengages: 15–20 mm (0.59–0.79 in) from the fully depressed position of the clutch pedal.

NOTE: A full stroke of the clutch pedal is 135–145 mm (5.3–5.7 in) from the fully released position.

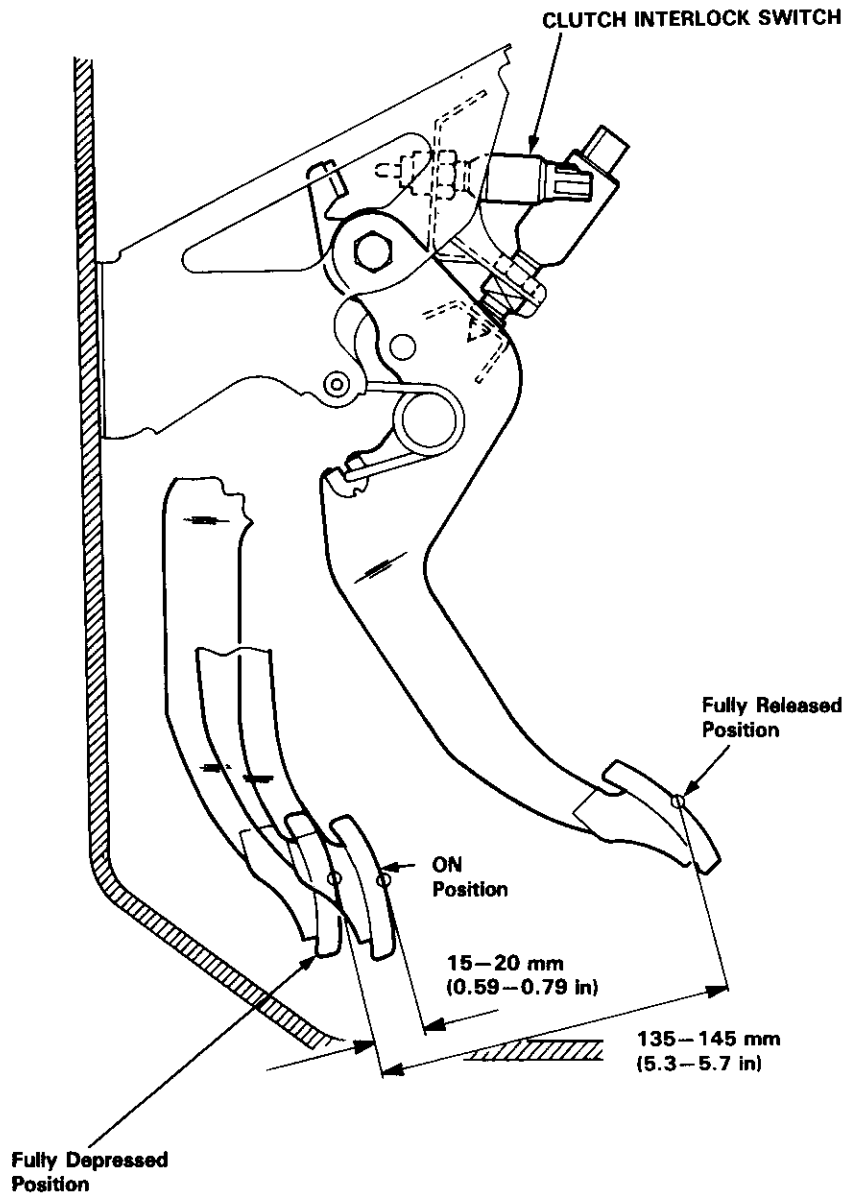

Starting System

Circuit Diagram

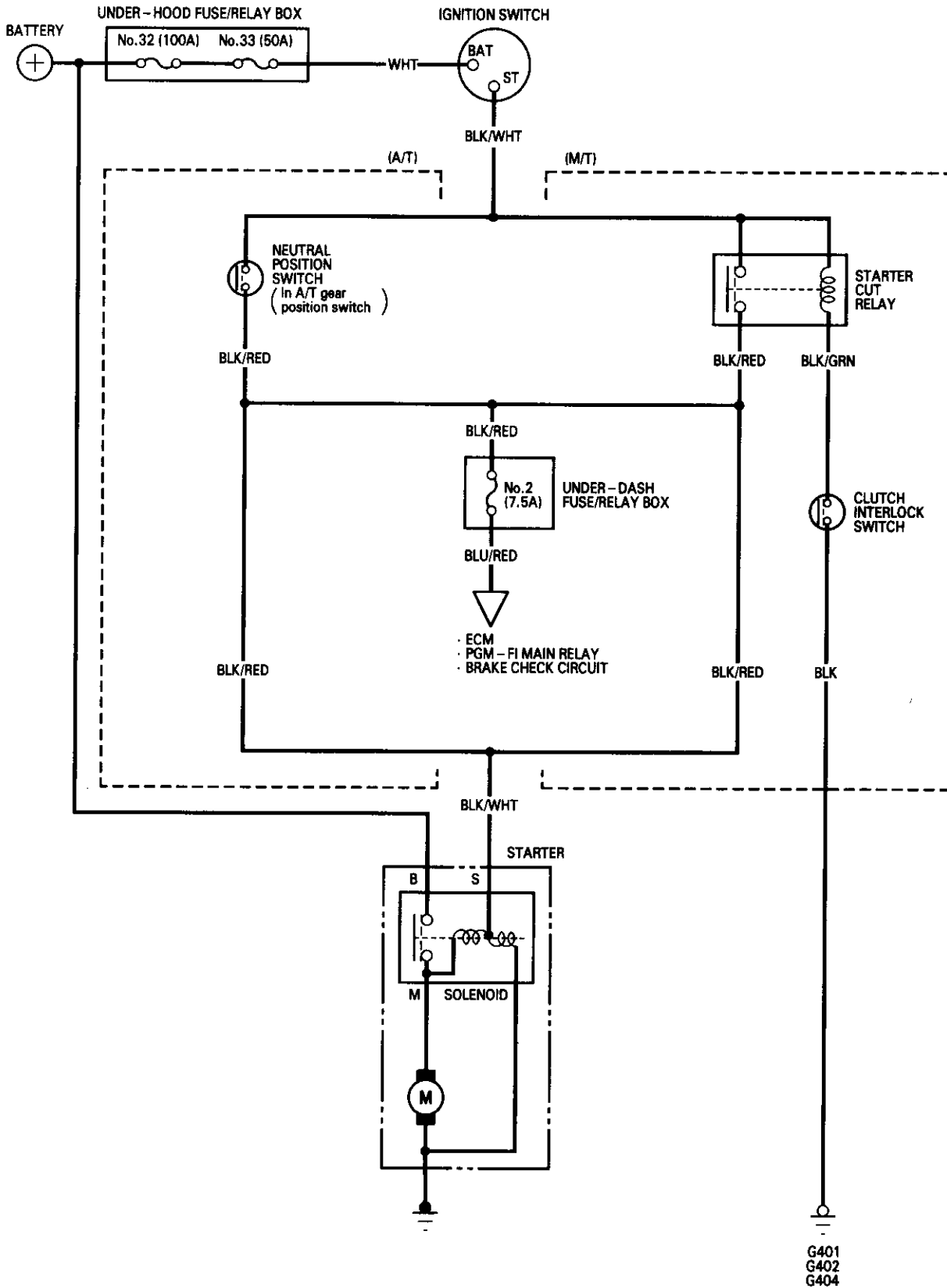



Starter Test

NOTE: The air temperature must be between 59 °F and 100 °F (15 °C and 38 °C) before testing.

Recommended Procedure:

- Use a starter system tester.
- Connect and operate the equipment in accordance with manufacturer's instructions.
- Test and troubleshoot as described.

Alternate Procedure:

- Use the following equipment:
 - Ammeter, 0–400 A
 - Voltmeter, 0–20 V (accurate within 0.1 volt)
 - Tachometer, 0–1200 rpm
- Hook up voltmeter and ammeter as shown.

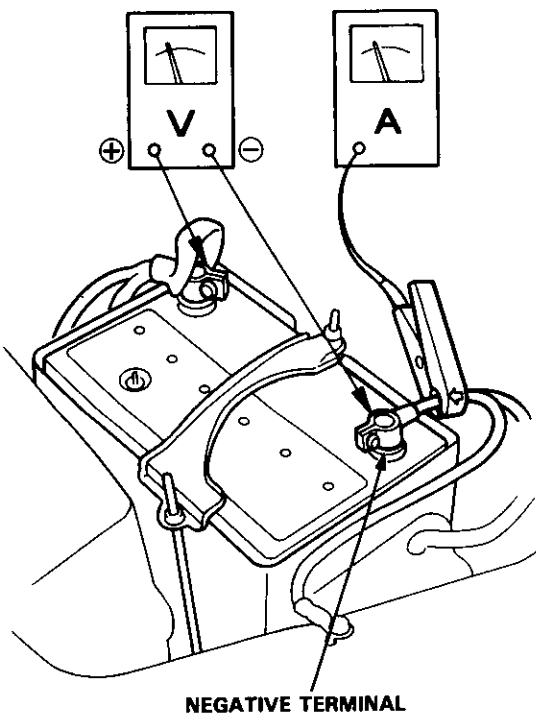

NOTE: After this test, or any subsequent repair, reset the ECM to clear any codes (see section 11).

1. Disconnect the 4-P connector from the ignition coil.

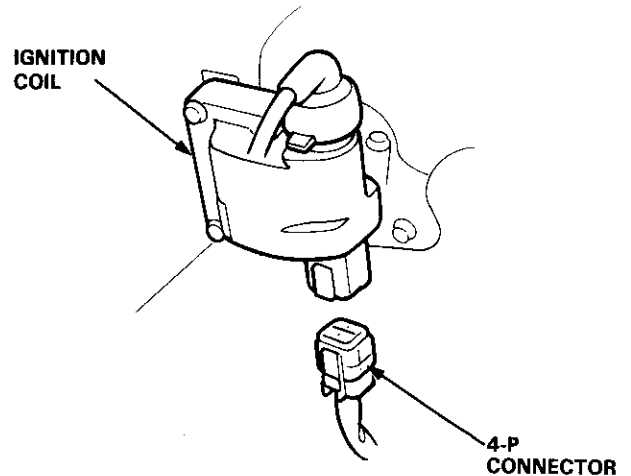

2. Check the starter engagement: Press the clutch pedal all the way in (M/T), and turn the ignition switch to "START". The starter should crank the engine.

NOTE: On cars equipped with manual transmission, the engine will not crank unless the clutch pedal is fully depressed.

- If the starter does not crank the engine, check the battery, battery positive cable, ground, and the wire connections for looseness and corrosion.
- Test again. If the starter still does not crank the engine, bypass the ignition switch circuit as follows: Unplug the BLK/WHT wire from the solenoid terminal. Connect a jumper wire from the battery positive (+) terminal to the solenoid terminal. The starter should crank the engine.

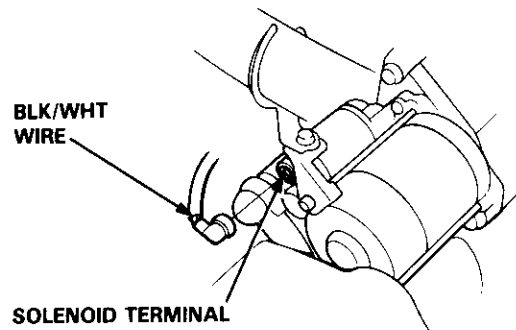

(cont'd)

Starting System

Starter Test (cont'd)

- If the starter still does not crank the engine, remove the starter and diagnose its internal problems.
- If the starter cranks the engine, check for an open in the BLK/WHT wire and connectors between the starter and ignition switch. Check the ignition switch. On cars with automatic transmission, check the A/T gear position switch (neutral position switch), and connectors. On cars with manual transmission, check the starter cut relay, clutch interlock switch, and connectors.

NOTE: Check the No. 33 (50 A) fuse in the underhood fuse/relay box and the starter cut relay.

3. Check for wear or damage:
The starter should crank the engine smoothly and steadily.

If the starter engages, but cranks the engine erratically, remove the starter motor. Check the starter, drive gear, and flywheel ring gear for damage. Check the drive gear overrunning clutch for binding or slipping when the armature is rotated with the drive gear held. Replace the gears if damaged.
4. Check cranking voltage and current draw:
Voltage should be no less than 8.5 volts.
Current should be no more than 380 amperes.
If voltage is too low, or current draw too high, check for:
 - Low battery.
 - Open circuit in starter armature commutator segments.
 - Starter armature dragging.
 - Shorted armature winding.
 - Excessive drag in engine.

5. Check cranking rpm:
Engine speed during cranking should be above 100 rpm.

If speed is too low, check for:

- Loose battery or starter terminals.
- Excessively worn starter brushes.
- Open circuit in commutator segments.
- Dirty or damaged helical spline or drive gear.
- Defective drive gear overrunning clutch.

6. Check the starter disengagement:
Press the clutch pedal all the way in (M/T), turn the ignition switch to "III" and release to "II" position. The starter drive gear should disengage from the flywheel ring gear.

If the drive gear hangs up on the flywheel ring gear, check for:

- Solenoid plunger and switch malfunction.
- Dirty drive gear assembly or damaged overrunning clutch.



Clutch Interlock Switch Test (M/T)

1. Remove the dashboard lower cover and knee bolster, then disconnect the 2-P connector from the switch.
2. Check for continuity between the terminals according to the table.

Terminal	A	B
Clutch pedal		
RELEASED		
PUSHED	○	○

CLUTCH INTERLOCK SWITCH

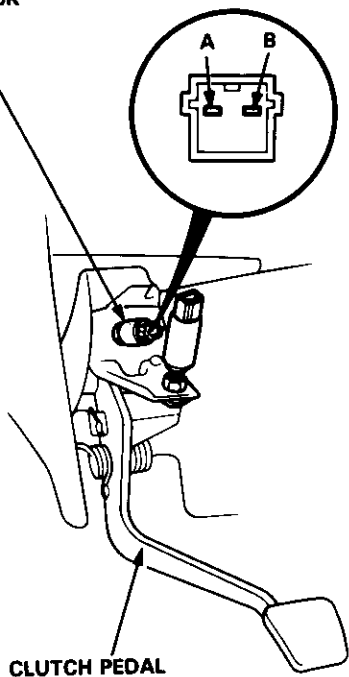

3. If necessary, replace the switch or adjust the switch position (see section 12).

Starter Replacement

NOTE: The radio may have a coded theft protection circuit. Be sure to get the customer's code number before

- Disconnecting the battery.
- Removing the No. 43 (10A) fuse. (In the under-hood fuse/relay box)
- Removing the radio.

After service, reconnect power to the radio and turn it on. When the word "CODE" is displayed, enter the customer's 5-digit code to restore radio operation.

1. Disconnect the negative cable from the battery.
2. Remove the engine wire harness from the harness clip on the starter motor.
3. Disconnect the starter cable from the B terminal on the solenoid, and the BLK/WHT wire from the S terminal.

NOTE: In case of an A/T model, the starter cable also has to be removed from the bracket on the transmission housing.

4. Remove the two mounting bolts holding the starter, then remove the starter motor.

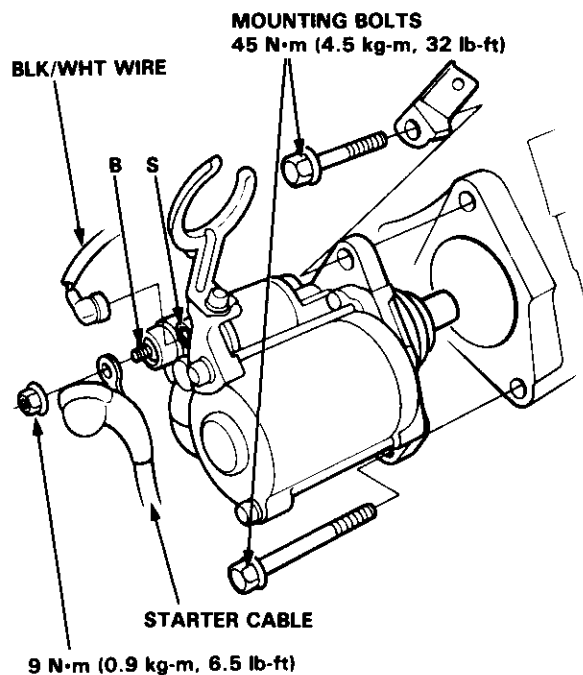

Starting System

Starting Overhaul

CAUTION: Before removing the starter, disconnect the ground cable from the battery.

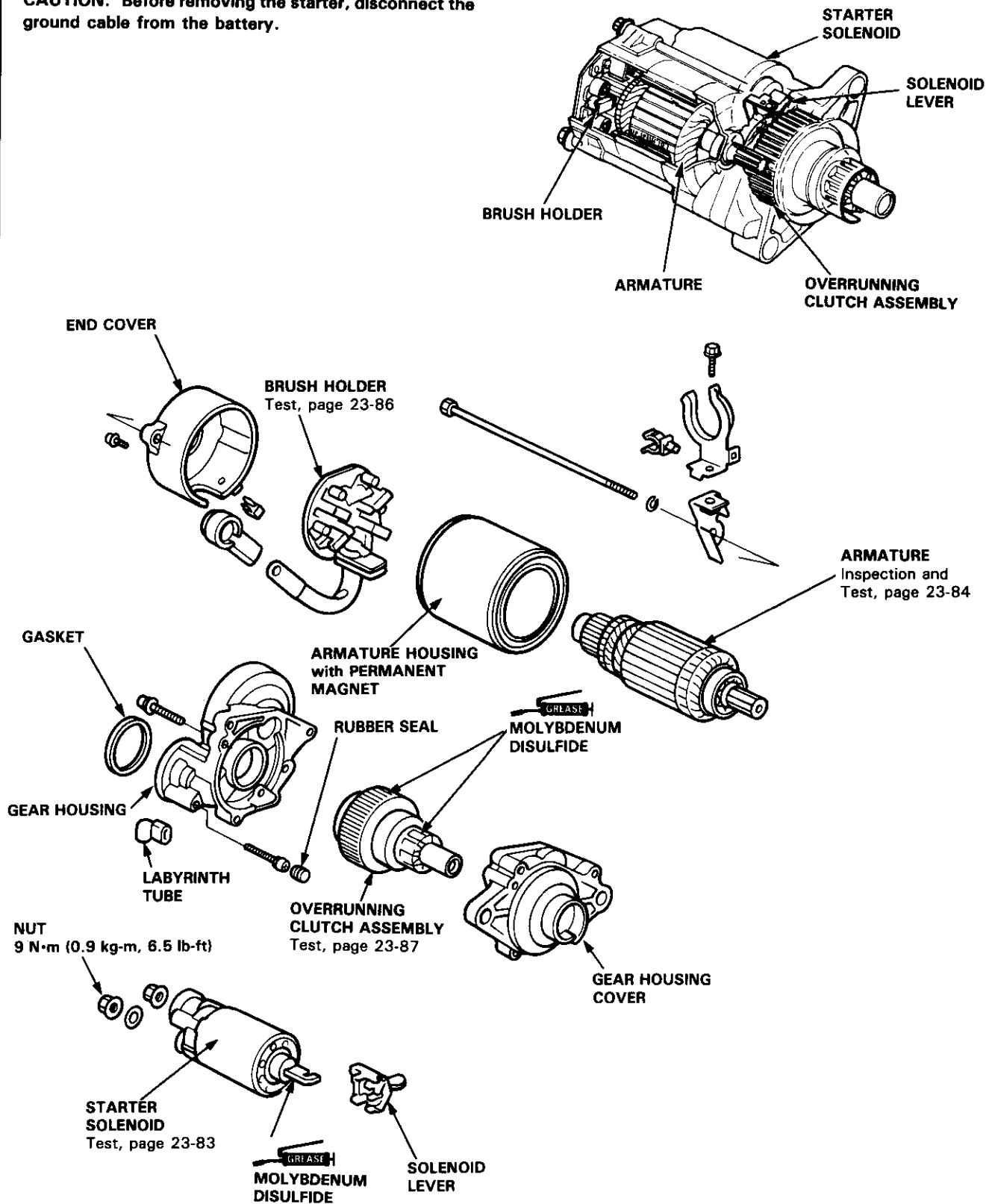



Starter Solenoid Test

1. Remove the starter solenoid.
2. Check for continuity between the terminals in each solenoid plunger position according to the table.

Terminal	B	M	S	GROUND
Position				
RELEASED		○	○	○
PUSHED	○	○	○	○

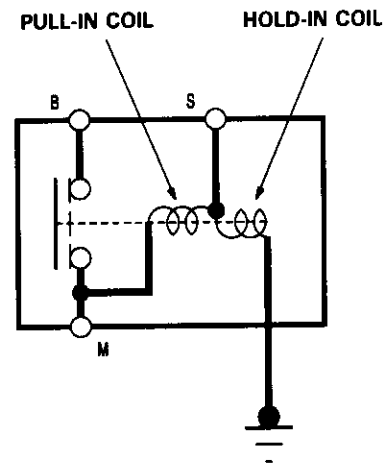
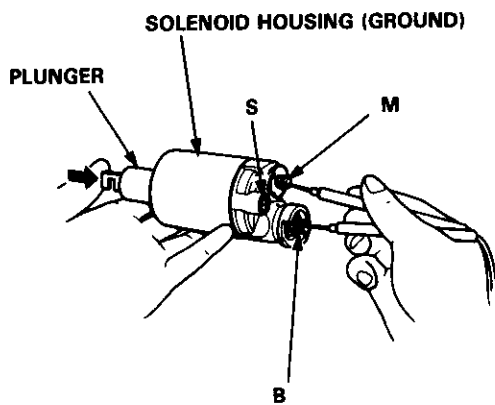

Starting System

Armature Inspection and Test

1. Inspect the armature surface for wear or damage.

Inspect for damage.

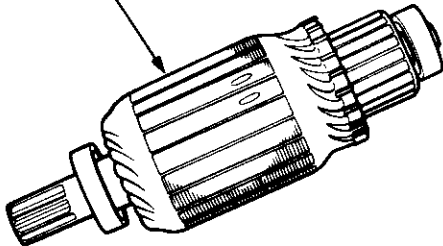

2. A dirty or burnt commutator surface may be resurfaced with emery cloth or a lathe within the following specifications.

Commutator Diameter

Standard (New): 28.0–28.1 mm
(1.102–1.106 in)

Service Limit : 27.5 mm (1.08 in)

VERNIER CALIPER

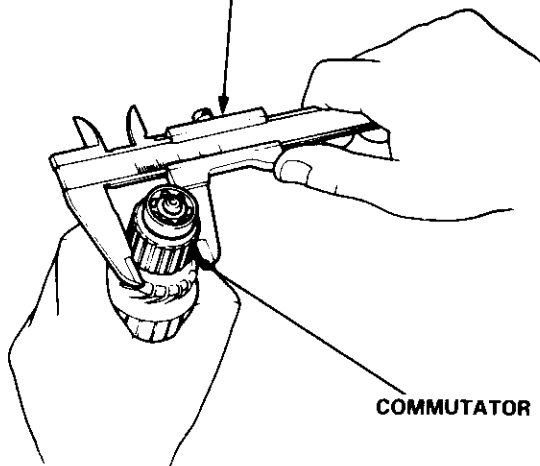

Commutator Runout

Standard (New): 0–0.02 mm (0–0.0008 in)

Service Limit : 0.05 mm (0.002 in)

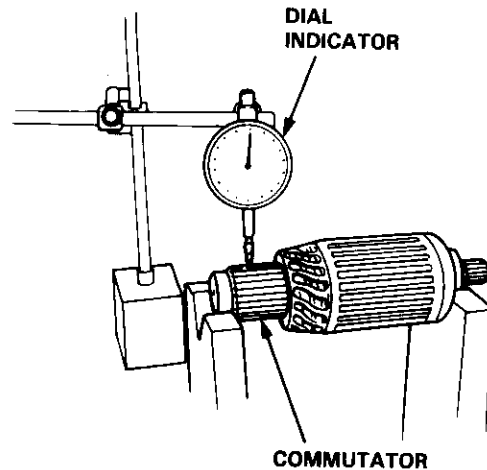

3. If the commutator runout and diameter are within limits, check the commutator for damage or for carbon dust or brass chips between the segments.
4. If the surface is dirty, recondition it with a #500 or #600 sandpaper. Then, check mica depth. If necessary, undercut the mica with a hacksaw blade to achieve proper depth.

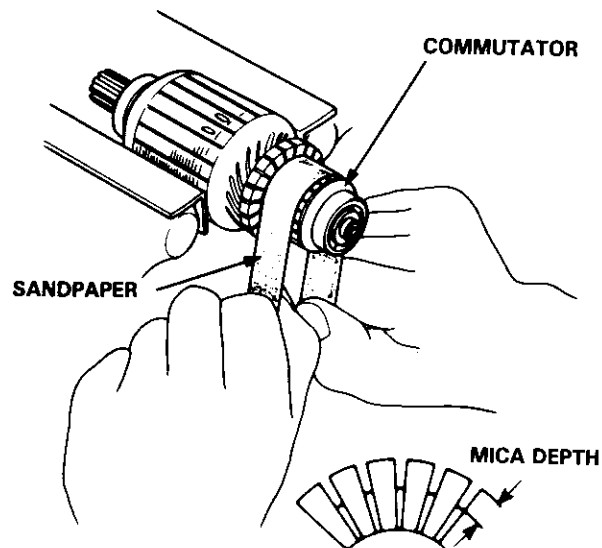

Commutator Mica Depth

Standard (New): 0.4–0.5 mm (0.016–0.020 in)

Service Limit : 0.15 mm (0.006 in)



5. Check for continuity between the segments of the commutator. If an open circuit exists between any segments, replace the armature.

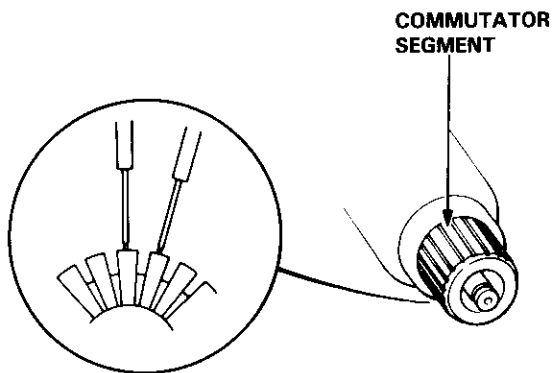

7. With an ohmmeter, check that no continuity exists between the commutator and armature coil core, and between the commutator and armature shaft. If continuity exists, replace the armature.

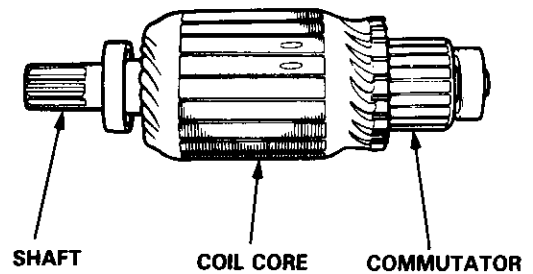

6. Place the armature on an armature tester. Hold a hacksaw blade on the armature core.

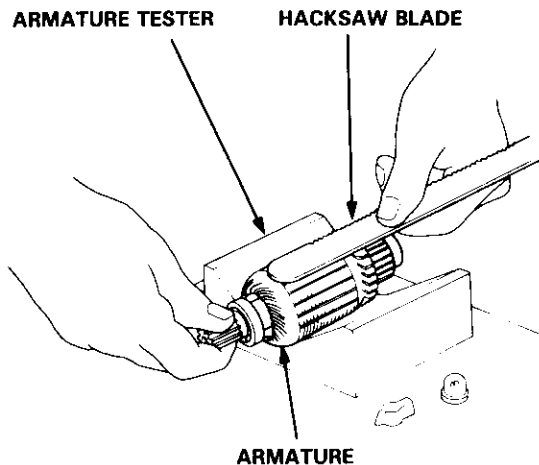

If the blade is attracted to the core or vibrates while the core is turned, the armature is shorted. Replace the armature.

Starting System

Starter Brush Holder Test

1. Check that there is no continuity between the ⊕ and ⊖ brush holders.
If continuity exists, replace the brush holder assembly.

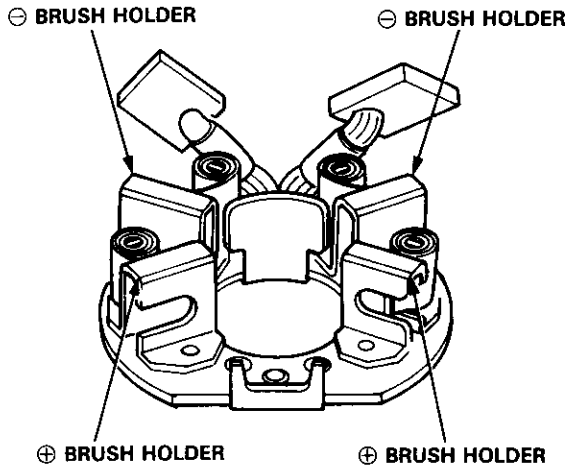

2. Insert the brush into the brush holder, and bring the brush into contact with the commutator, then attach a spring scale to the spring. Measure the spring tension at the moment the spring lifts off the brush.

	Spring Tension
Mitsuba (1.4KW)	16–18 N (1.6–1.8 kg, 3.5–4.0 lbs)
Mitsuba (1.6KW)	16–18 N (1.6–1.8 kg, 3.5–4.0 lbs)

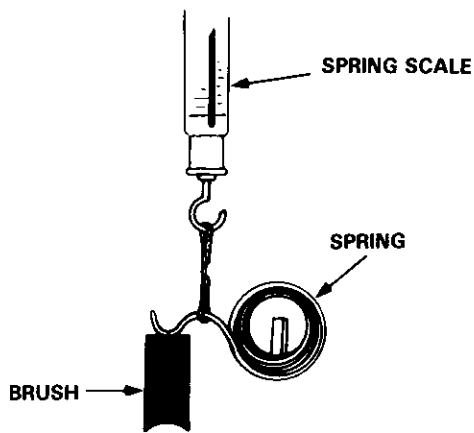

Starter Brush Inspection

Measure brush length. If not within the service limit, replace the armature housing and brush holder assembly.

Brush Length

Standard (New): 15.8–16.2 mm (0.62–0.64 in)

Service Limit : 10.0 mm (0.39 in)

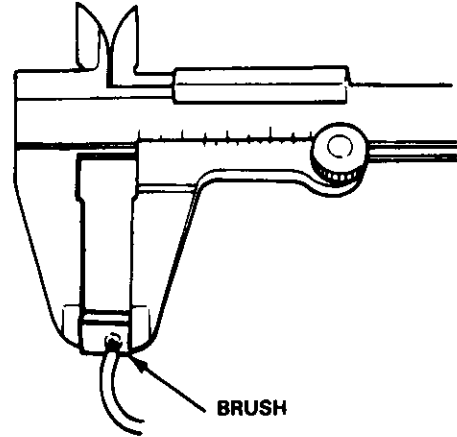

NOTE: To seat new brushes after installing them in their holders, slip a strip of #500 or #600 sandpaper, with the grit side up, over the commutator, and smoothly rotate the armature. The contact surface of the brushes will be sanded to the same contour as the commutator.



Overrunning Clutch Check

1. Check that the overrunning clutch moves along the shaft freely. If not, replace it.
2. Check that the overrunning clutch locks in one direction and rotates smoothly in reverse. If it does not lock in either direction or it locks in both directions, replace it.

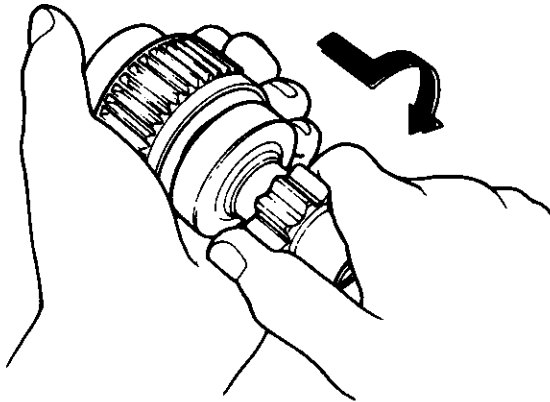

3. Check the starter drive gear for wear and damage. If the gear is worn or damaged, replace the overrunning clutch assembly; the gear is not available separately.

NOTE: Check the condition of the flywheel or torque converter ring gear if the starter drive gear teeth are damaged.

Starter Reassembly

Reassemble the starter in the reverse order of disassembly.

1. Pry back each brush spring with a screwdriver, then position the brush about halfway out of its holder, and release the spring to hold it there.

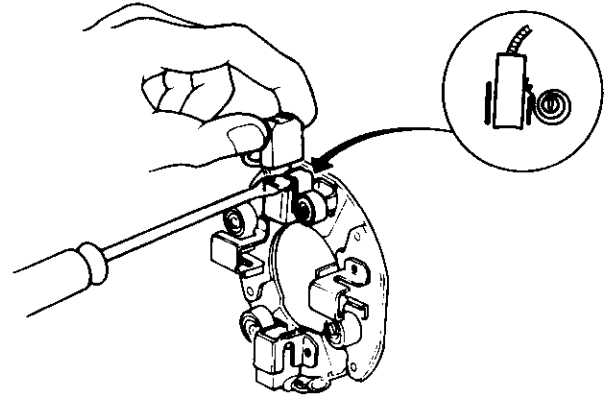

2. Install the armature in the housing. Next pry back each brush spring again and push the brush down until it seats against the commutator, then release the spring against the end of the brush.

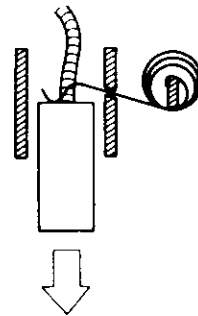

3. Install the end cover on the brush holder.

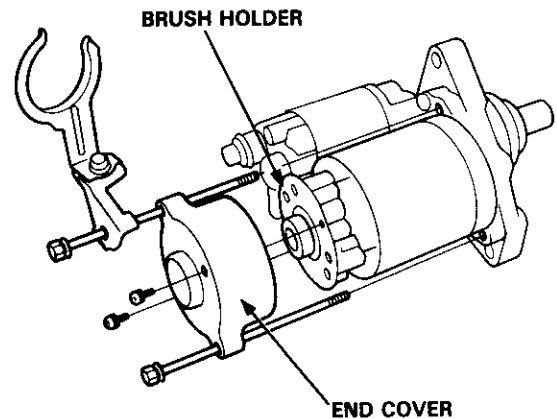

Starting System

Performance Test

NOTE: Before starting the following checks, disconnect the wire from terminal M, and make a connection as described below using as heavy a wire as possible (preferably equivalent to the wire used for the car).

Pull-in Coil Test:

Connect the battery as shown. If the pinion protrudes, it is working properly.

NOTE: Do not leave the battery connected for more than 10 seconds.

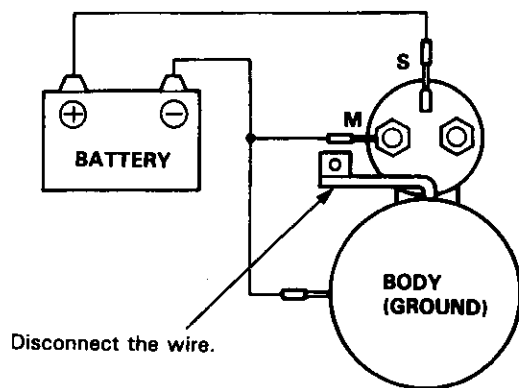

Hold-in Coil Test:

Disconnect the battery from the M terminal. If the pinion does not retract, the hold-in coil is working properly.

NOTE: Do not leave the battery connected for more than 10 seconds.

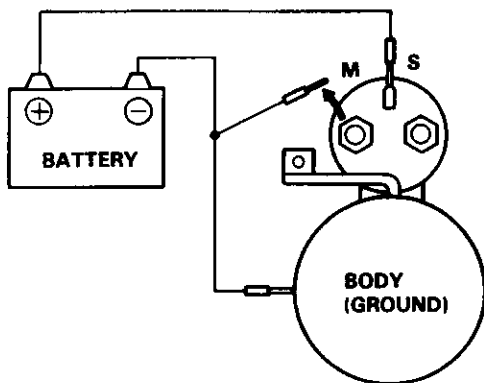

Retracting Test:

Also disconnect the battery from the body. If the pinion retracts immediately, it is working properly.

NOTE: Do not leave the battery connected for more than 10 seconds.

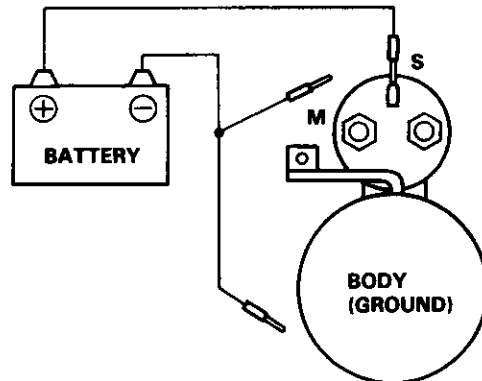



Starter No-load Test:

1. Clamp the starter firmly in a vise.
2. Connect the starter to the battery as described in the diagram below and confirm that the motor starts and keeps rotating.
3. If the electric current and motor speed meet the specifications when the battery voltage is at 11V, the starter is working properly.

Specifications:

**Mitsuba: 80 A or less (electric current),
(1.4KW) 2600 rpm or more (motor speed)**

**Mitsuba: 80 A or less (electric current),
(1.6KW) 2600 rpm or more (motor speed)**

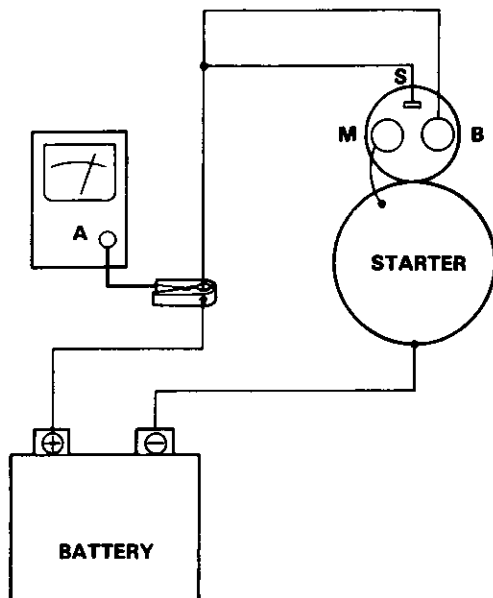

Ignition System

Component Location Index

IGNITION TIMING CONTROL SYSTEM

- Description, page 23-91
- Troubleshooting, section 11
- Inspection and Setting, page 23-93

DISTRIBUTOR

- Top End Inspection, page 23-95
- Removal/Installation, page 23-95, 97
- Overhaul, page 23-96
- Reassembly, page 23-99
- Ignition Control Module (ICM)
Troubleshooting, section 11
- ICM Input Test, page 23-98

TEST TACHOMETER CONNECTOR

IGNITION COIL

- Test, page 23-100

SERVICE CHECK CONNECTOR (2-P)

IGNITION WIRES

- Inspection and Test, page 23-99

SPARK PLUG

- Inspection, page 23-101

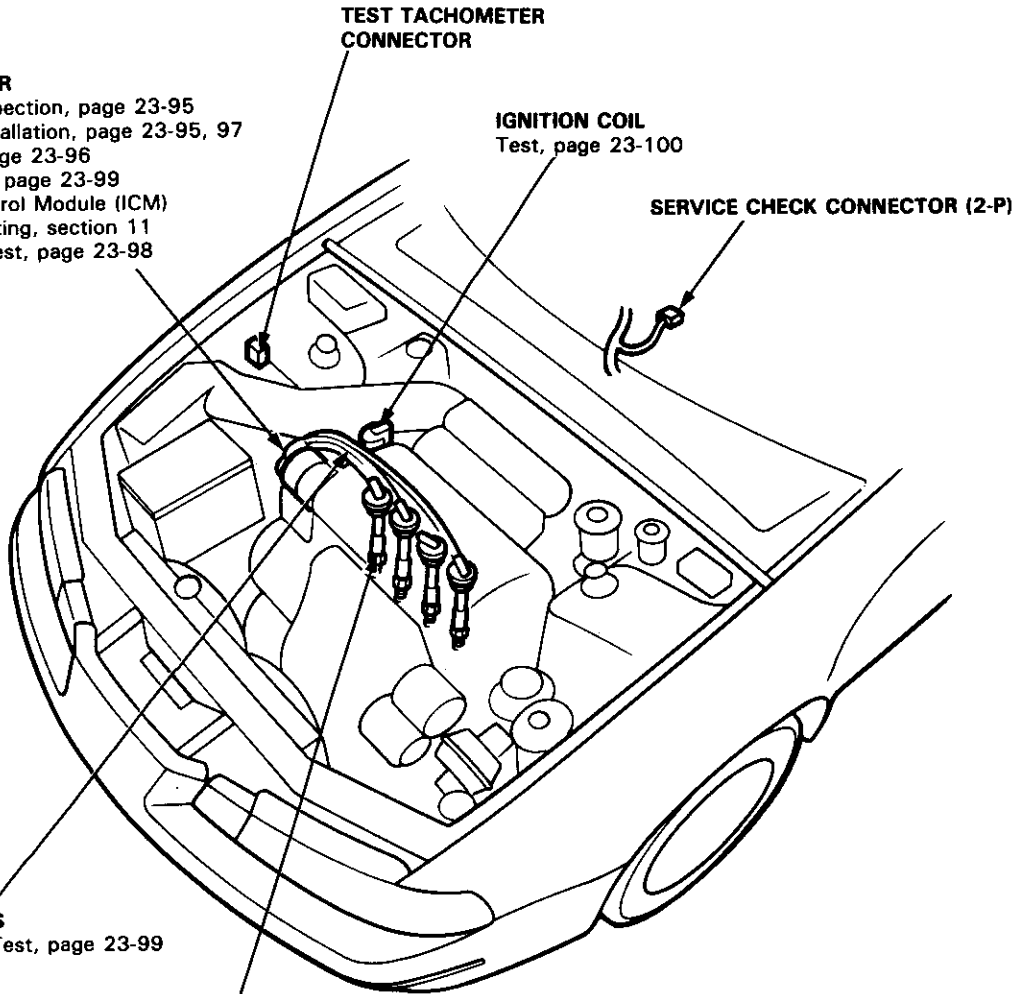



Description

Ignition Timing Control:

The programmed ignition (PGM-IG) used in this engine provides optimum control of ignition timing. A microcomputer determines the timing in response to engine speed and manifold vacuum. The input signals are transmitted by the TDC/CKP/CYP sensor, throttle position (TP) sensor, engine coolant temperature (ECT) sensor, and MAP sensor. This system, which is not dependent on a governor or vacuum diaphragm, is capable of setting lead angles with complicated characteristics which cannot be provided by conventional governors or diaphragms.

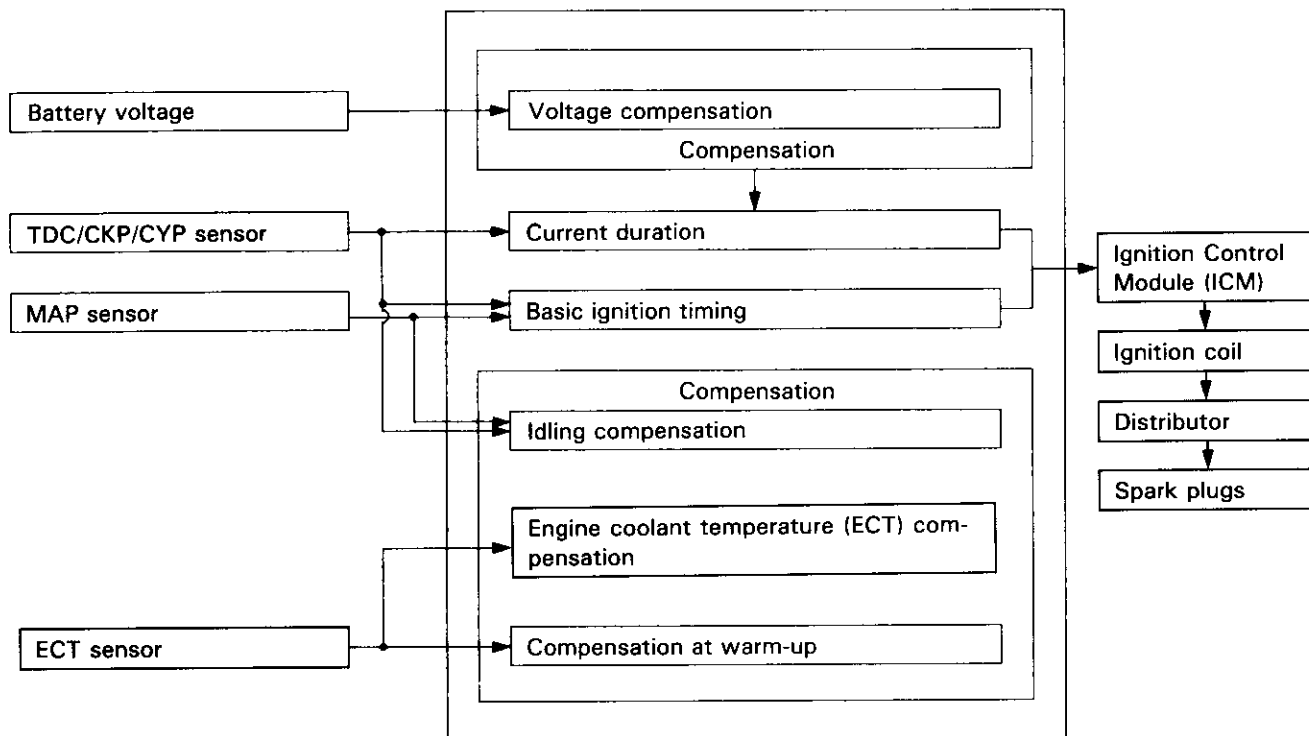

Basic Control:

The control unit has stored within it the optimum basic ignition timing for operating conditions based upon engine speed and intake manifold pressure. With compensating signals from sensors, the system determines optimum ignition timing and duration for ambient conditions and sends voltage pulses to the ICM.

Compensation of ignition timing:

Compensation Item	Related Sensor and Information	Description
Idling	TDC/CKP/CYP sensor MAP sensor	Ignition timing is controlled to the target speed with compensation according to the idling speed.
Compensation at warm-up	ECT sensor	Lag angle is adjusted according to warm-up conditions to bring about a good balance between operating performance and exhaust gas level.
ECT compensation	ECT sensor	Compensation for lead angle at low engine coolant temperature and lag angle at high engine coolant temperature.

Control at Start:

Ignition timing is fixed at 7° BTDC for cranking. The cranking is detected by the TDC sensor (cranking rpm) and starter signal.

Ignition System

Circuit Diagram

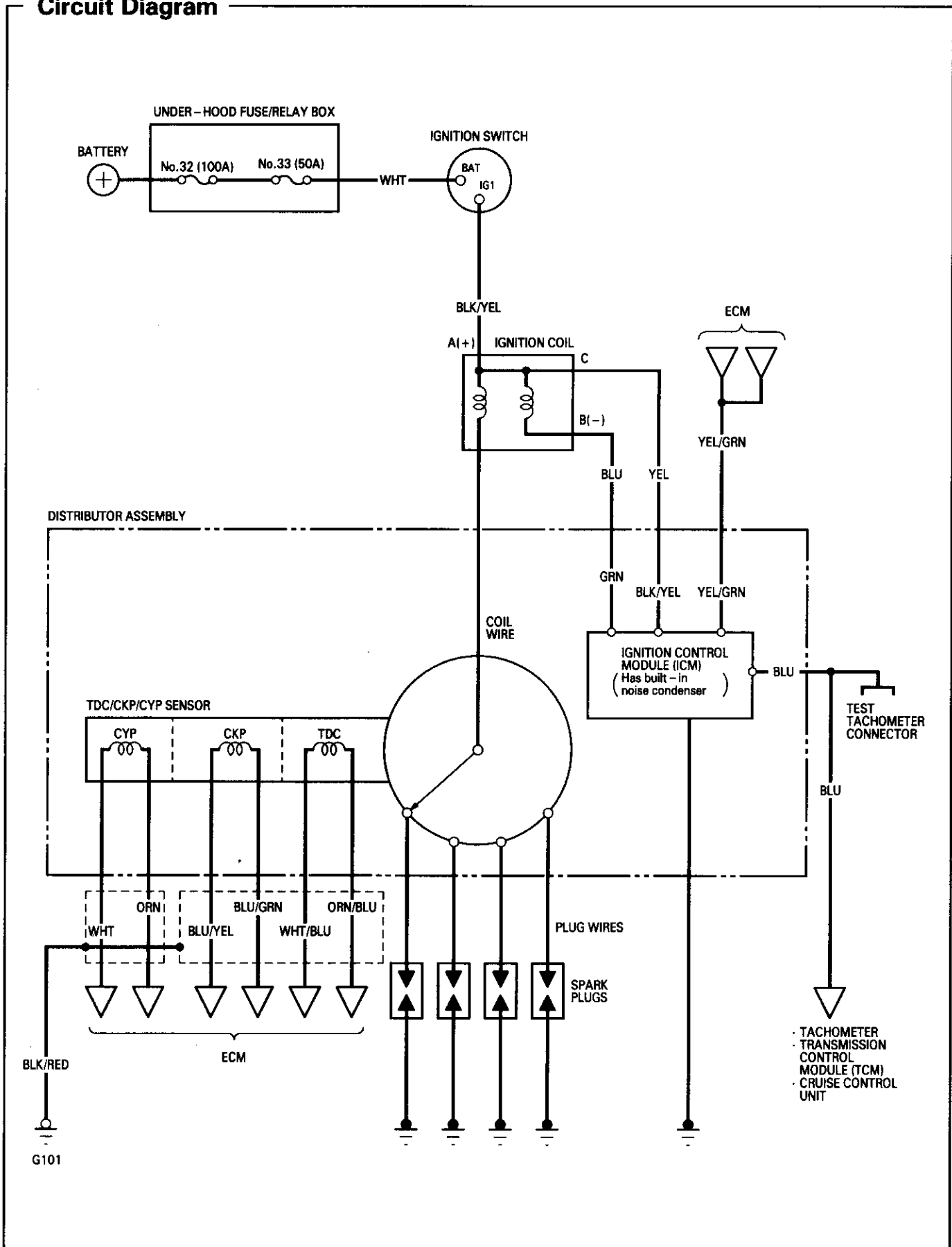



Ignition Timing Inspection and Setting

CAUTION:

- All SRS electrical wiring harnesses are covered with yellow outer insulation.
- Before disconnecting the SRS wire harness, install the short connector(s) on the airbag(s) (see page 23-294).
- Replace the entire affected SRS harness assembly if it has an open circuit or damaged wiring.

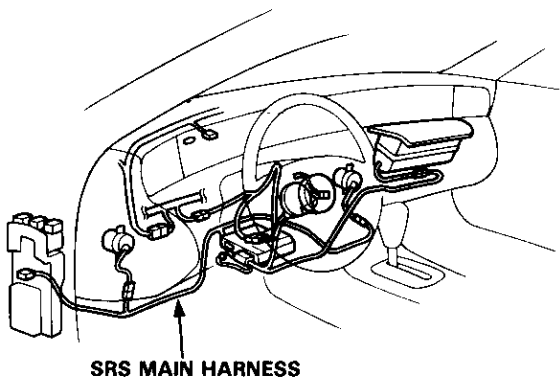

1. Start the engine and allow it to warm up (radiator fan comes on).
2. Pull out the service check connector located under the middle of the dash. Connect the BLU/WHT and BRN/WHT terminals with a jumper wire.

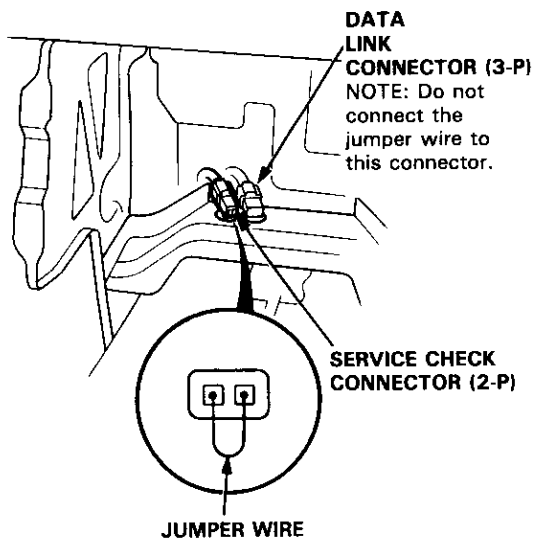

3. Check the idle speed (see page 23-94).

4. Connect a timing light to the No. 1 ignition wire. Remove the rubber plug from the "window" in the flywheel/drive plate housing. While the engine idles, point the light toward the pointer on the flywheel (for M/T) or on the drive plate (for A/T).

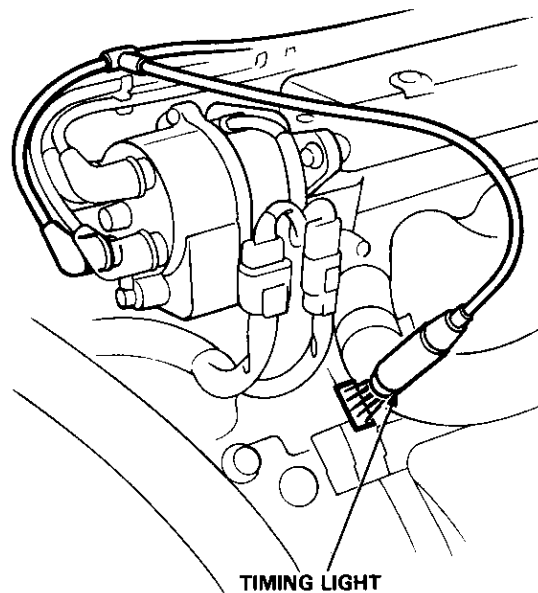

5. Adjust ignition timing, if necessary, to the following specifications:

Ignition Timing: $15 \pm 2^\circ$ BTDC (RED)
at 700 ± 50 rpm with shift lever in neutral position and electrical systems turned off.

NOTE: The illustration shows A/T.

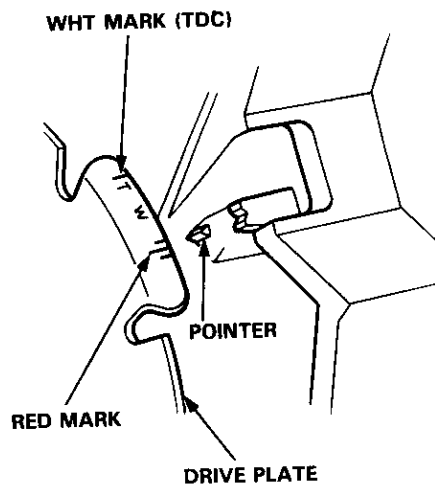

(cont'd)

Ignition System

Ignition Timing Inspection and Setting (cont'd)

6. If it is necessary to adjust the ignition timing, loosen the distributor mounting bolts, and turn the distributor housing counterclockwise to advance the timing, or clockwise to retard the timing.

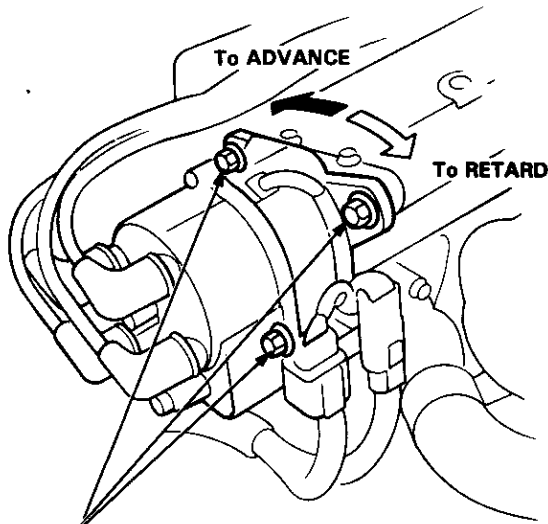

MOUNTING BOLTS
18 N·m (1.8 kg-m, 13 lb-ft)

7. Tighten the mounting bolts and recheck timing.
8. Remove the jumper wire from the service check connector (2-P) and reinstall the rubber plug in the inspection window.

Idle Speed Inspection

1. Start the engine and allow it to warm up (radiator fan comes on).
2. Connect a tachometer to the test tachometer connector.

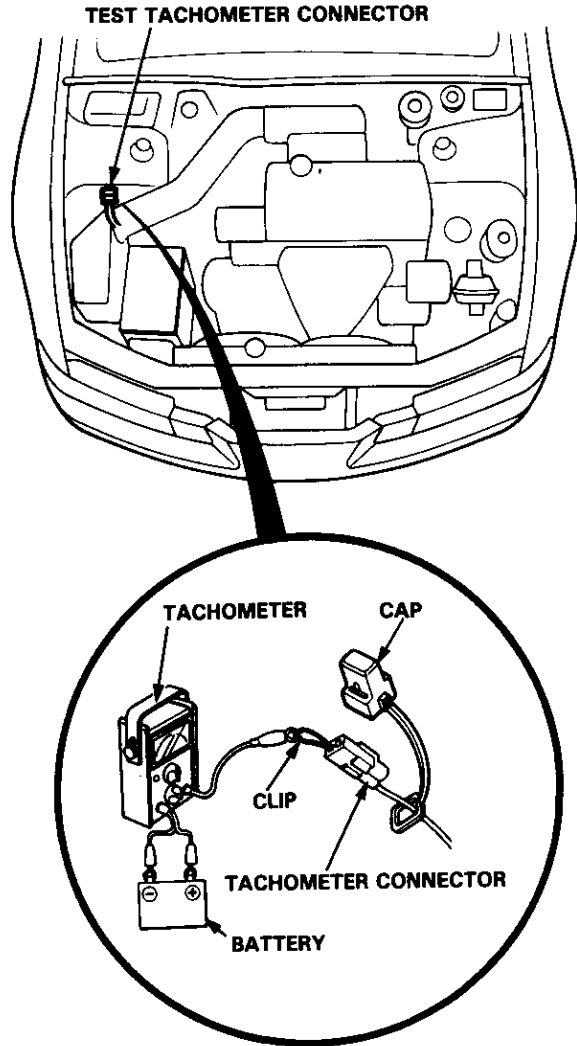

Idle speed: 700 ± 50 rpm with shift lever in neutral position and electrical systems turned off.

3. Adjust the idle speed if necessary (see section 11).



Distributor Removal

1. Disconnect the 2-P and 8-P connectors from the distributor.
2. Disconnect the ignition wires from the distributor cap.

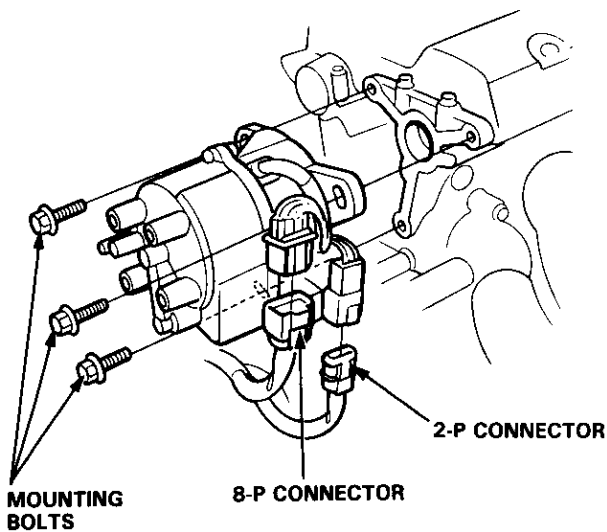

3. Remove the distributor mounting bolts, then remove the distributor from the cylinder head.

Distributor Top End Inspection

1. Check for rough or pitted rotor and cap terminals.
2. Scrape or file off the carbon deposits and smooth with an oil stone or #600 sandpaper.

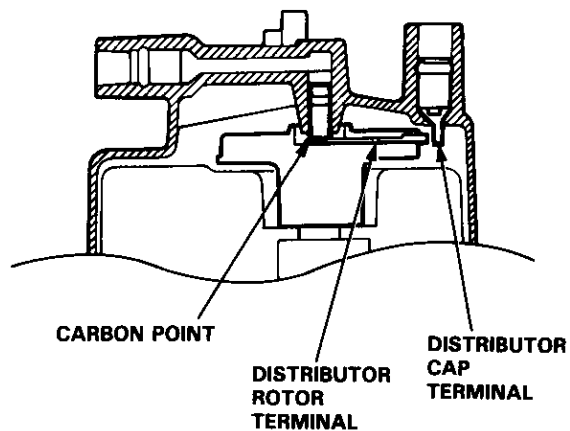

3. Check the distributor cap for cracks, wear, and damage. If necessary, clean or replace it.

Ignition System

Distributor Overhaul

**DISTRIBUTOR
CAP SEAL**
Check for damage.

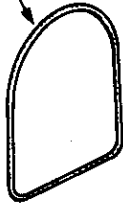

INNER COVER

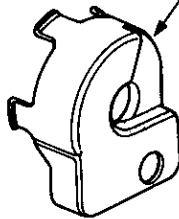

CARBON POINT

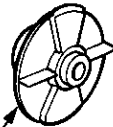

DISTRIBUTOR ROTOR

**CARBON POINT
SPRING**

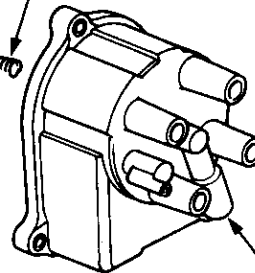

GRN
BLK/YEL
YEL/GRN

BLU

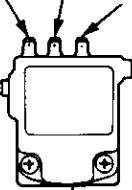

**IGNITION
CONTROL
MODULE
(ICM)**

ICM
Troubleshooting, section 11
Input Test, page 23-98

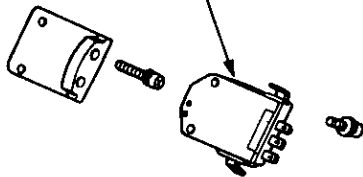

CAP
Check for cracks, wear,
damage, and fouling.
Clean or replace.



PIN RETAINER **COUPLING**



O-RING
Replace.



TDC/CKP/CYP SENSOR
Troubleshooting, section 11
Do not disassemble.

PIN

THRUST WASHER

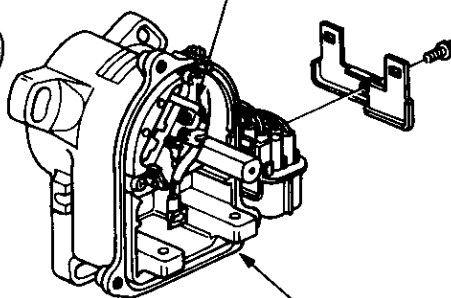

**DISTRIBUTOR
HOUSING**
Check for cracks
and damage.



Distributor Installation

1. Coat a new O-ring with engine oil, then install it.
2. Slip the distributor into position.

NOTE: The lugs on the end of the distributor, and the mating grooves in the camshaft end are both offset to eliminate the possibility of installing the distributor 180° out of time.

**DISTRIBUTOR
END**

**CAMSHAFT
END**

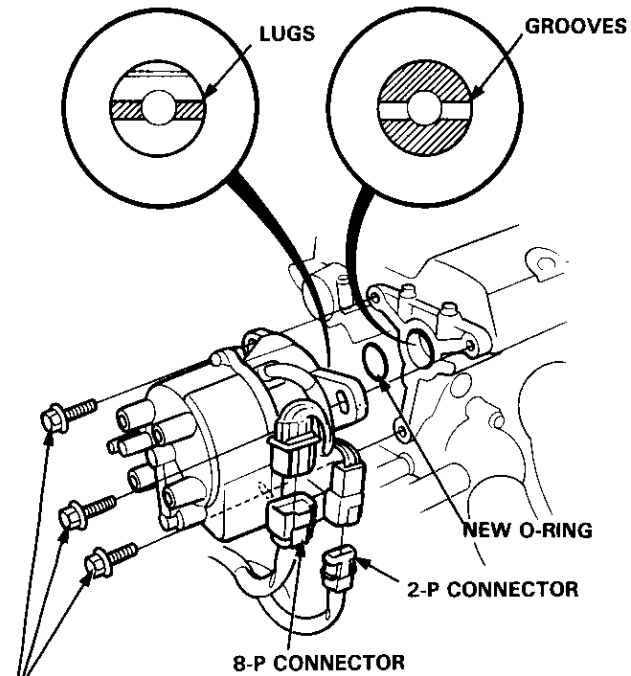

MOUNTING BOLTS
18 N·m (1.8 kg-m, 13 lb-ft)

3. Install the mounting bolts and tighten them temporarily.
4. Connect the 2-P and 8-P connectors to the distributor.

5. Connect the ignition wires as shown.

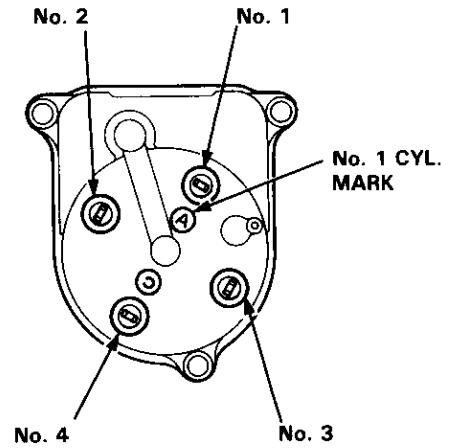

6. Set the timing with a timing light as shown on page 23-94.
7. After setting the timing, tighten the mounting bolts.

Ignition System

Ignition Control Module (ICM) Input Test

NOTE:

- See section 11 when the malfunction indicator lamp (MIL) blinks.
- Perform an input test for the ignition control module (ICM) after finishing the fundamental tests for the ignition system and the fuel and emissions system.
- The tachometer should operate normally.

1. Remove the distributor cap, the distributor rotor, and the inner cover.
2. Disconnect the BLK/YEL, GRN, YEL/GRN, and BLU wires from the ICM.

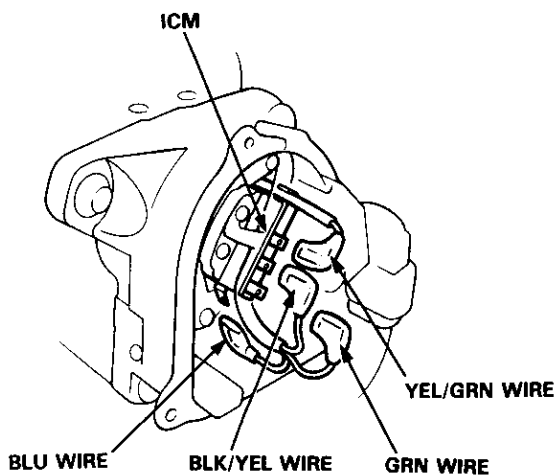

3. Turn the ignition switch ON. Check for voltage between the BLK/YEL wire and body ground. There should be battery voltage.
 - If there is no battery voltage, check the BLK/YEL (YEL) wire between the ignition coil and the ICM.
 - If there is battery voltage, go to step 4.
4. Turn the ignition switch ON. Check for voltage between the GRN wire and body ground. There should be battery voltage.
 - If there is no battery voltage, check the:
 - Ignition coil.
 - GRN (BLU) wire between the ignition coil and the ICM.
 - If there is battery voltage, go to step 5.

5. Check the YEL/GRN wire between the ECM and the ICM (see section 11).
6. Check the BLU wire between the tachometer and the ICM.
7. If all tests are normal, replace the ICM.



Distributor Reassembly

Reassemble the distributor in the reverse order of disassembly.

1. Install the distributor rotor, then turn it so that it faces in the direction shown (toward the No. 1 cylinder).

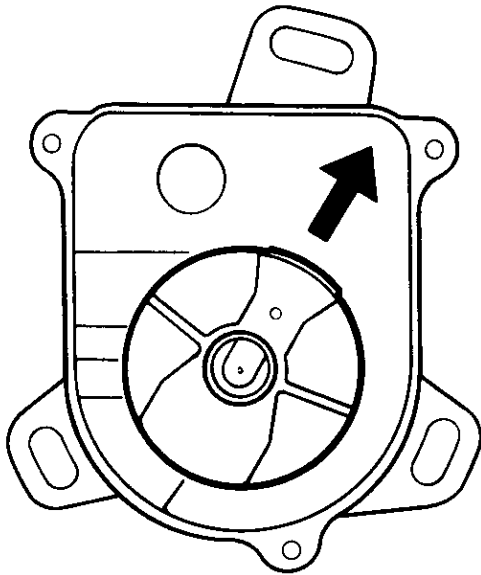

2. Set the thrust washer and coupling on the shaft.
3. Check that the distributor rotor is still pointing toward the No. 1 cylinder, then align the index mark on the distributor housing with the index mark on the coupling.

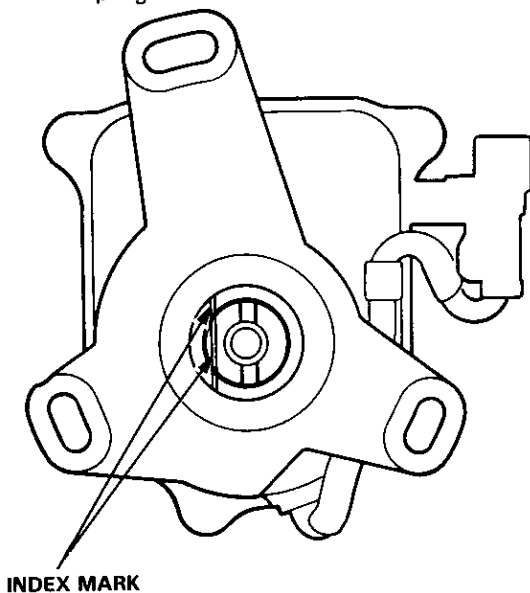

4. Drive in the pin and secure it with the pin retainer.

Ignition Wire Inspection and Test

CAUTION: Carefully remove the ignition wires by pulling on the rubber boots. Do not bend the wires; you might break them inside.

1. Check the condition of the wire terminals. If any terminal is corroded, clean it, and if it is broken or distorted, replace the wire.

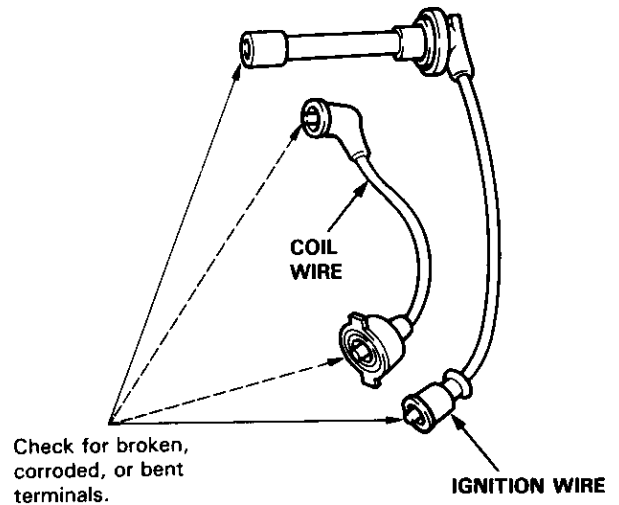

Check for broken, corroded, or bent terminals.

2. Connect ohmmeter probes and measure resistance.

Ignition Wire Resistance:
25 k Ω max. at 68 °F (20 °C)

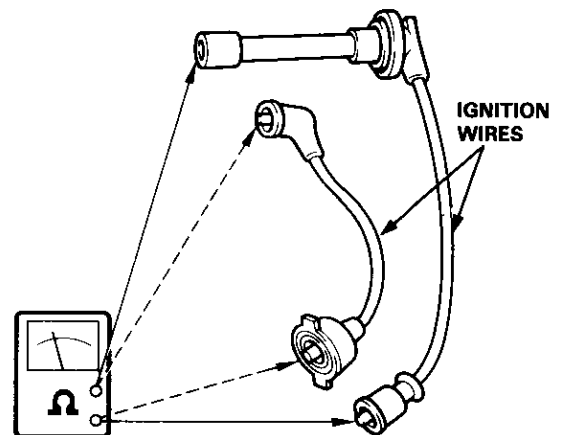

3. If resistance exceeds 25 k Ω , replace the ignition wire.

Ignition System

Ignition Coil Test

1. Turn the ignition switch OFF.
2. Disconnect the 4-P connector and ignition coil wire.

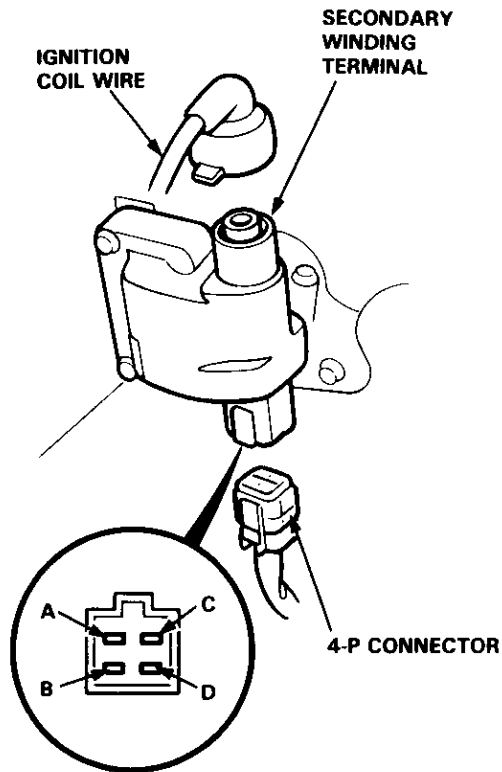

3. Using an ohmmeter, measure resistance between the terminals. Replace the coil if the resistance is not within specifications.

NOTE: Resistance will vary with the coil temperature; specifications are at 68 °F (20 °C).

Primary Winding Resistance
(between the A and B terminals):
0.6–0.8 Ω

Secondary Winding Resistance
(between the A and secondary winding terminals):
14–22 k Ω

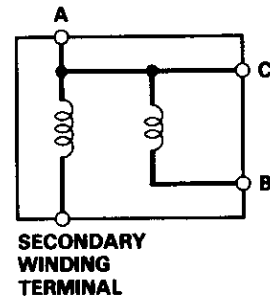

4. Check for continuity between the A and C terminals. Replace the coil if there is no continuity.



Spark Plug Inspection

1. Inspect the electrodes and ceramic insulator for:

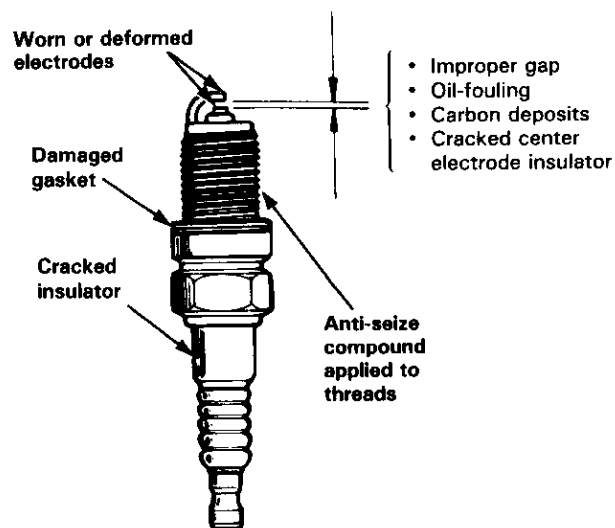

Burned or worn electrodes may be caused by:

- Advanced ignition timing
- Loose spark plug
- Plug heat range too low
- Insufficient cooling

Fouled plug may be caused by:

- Retarded ignition timing
- Oil in combustion chamber
- Incorrect spark plug gap
- Plug heat range too high
- Excessive idling/low speed running
- Clogged air cleaner element
- Deteriorated ignition coil or ignition wires

2. **F22A1/H23A1 engine:** Adjust the gap with a suitable gapping tool.

Electrode Gap: 1.1 mm (0.043 in)

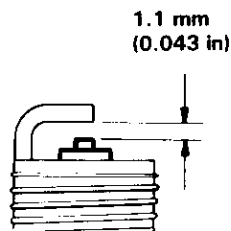

H22A1 engine: Make sure that the 1.3 mm (0.051 in) plug gauge does not go into the gap for the platinum tip plug. If the gauge goes into the gap, do not attempt to adjust the side electrode; replace the plug with a new one.

Electrode Gap:

Standard	1.0–1.1 mm (0.039–0.043 in)
Service Limit	1.3 mm (0.051 in)

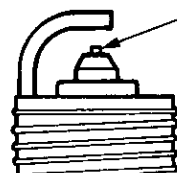

Platinum tip plug:

Check and confirm that the 1.3 mm (0.051 in) plug gauge does not go into the gap.

3. Replace the plug if it is fouled or worn.

NOTE: Use only the spark plugs listed below.

F22A1 Engine

ZFR5F-11 (NGK) KJ16CR-L11 *(ND)	For all normal driving.
ZFR6F-11 (NGK) KJ20CR-L11 *(ND)	For hot climates or continuous high speed driving.

H23A1 Engine

ZFR6F-11 (NGK) KJ20CR-L11 *(ND)	For all normal driving.
ZFR7F-11 (NGK) KJ22CR-L11 *(ND)	For hot climates or continuous high speed driving.

H22A1 Engine

PZFR6F-11 (NGK) PKJ20CR-L11 *(ND)	For all normal driving.
PFR7G-11 (NGK) PK22PR-L11 *(ND)	For hot climates or continuous high speed driving.

*(ND): NIPPONDENSO

4. Apply a small quantity of anti-seize compound to the plug threads.
5. Screw the plugs into the cylinder head finger-tight, then torque them to 18 N·m (1.8 kg-m, 13 lb-ft).

Charging System

Component Location Index

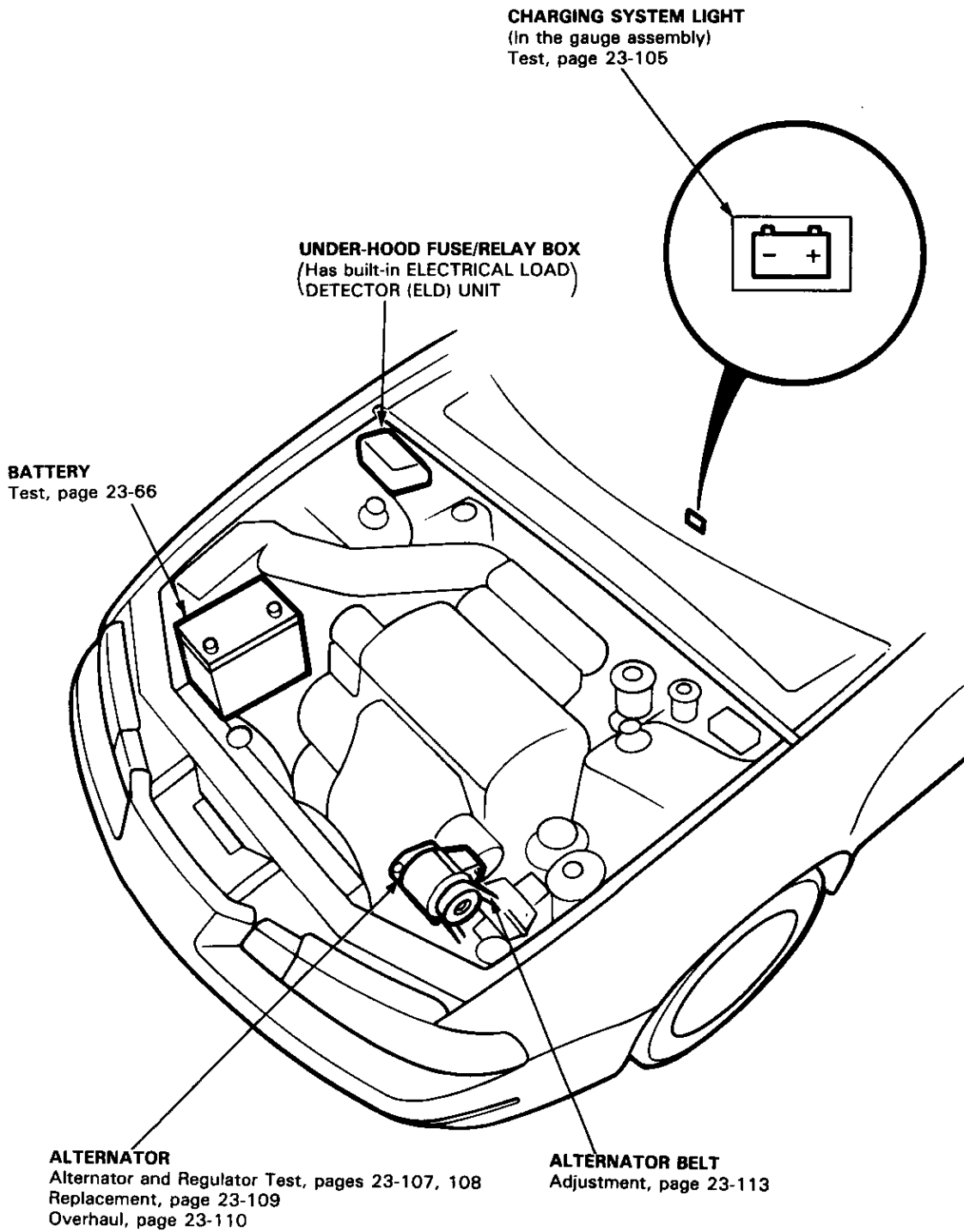



Description

To improve fuel economy, the alternator control system within the ECM changes the voltage generated at the alternator in accordance with driving conditions.

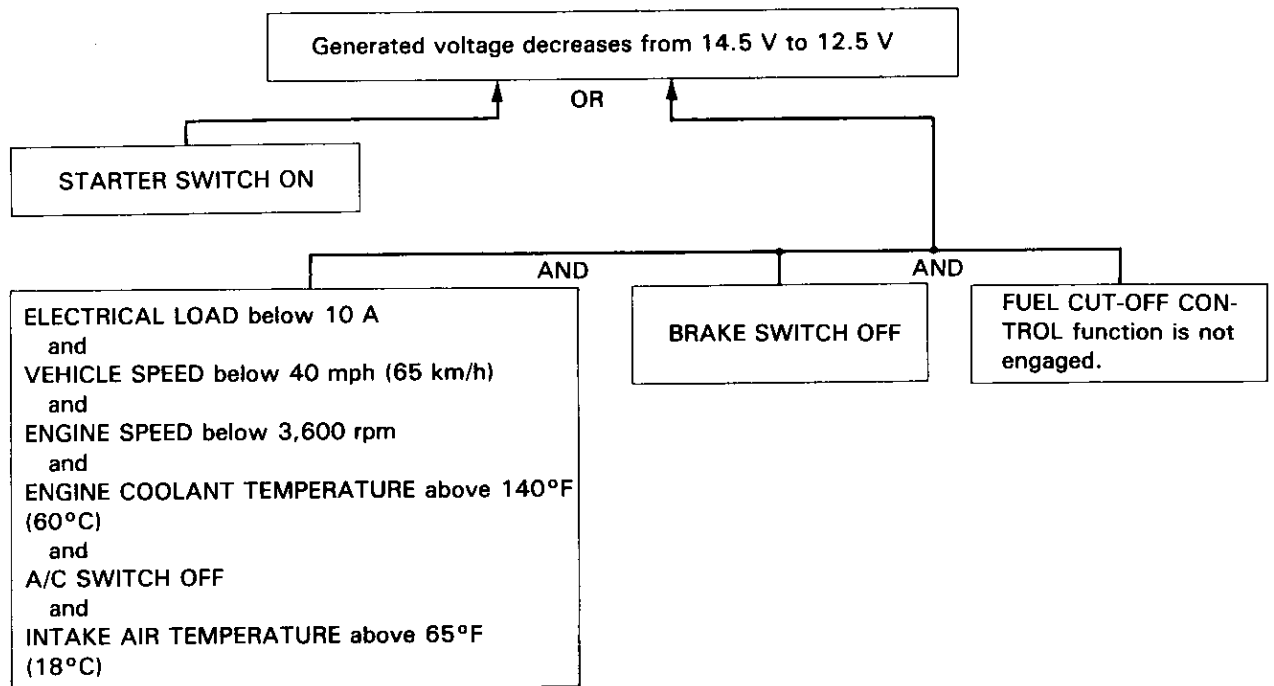
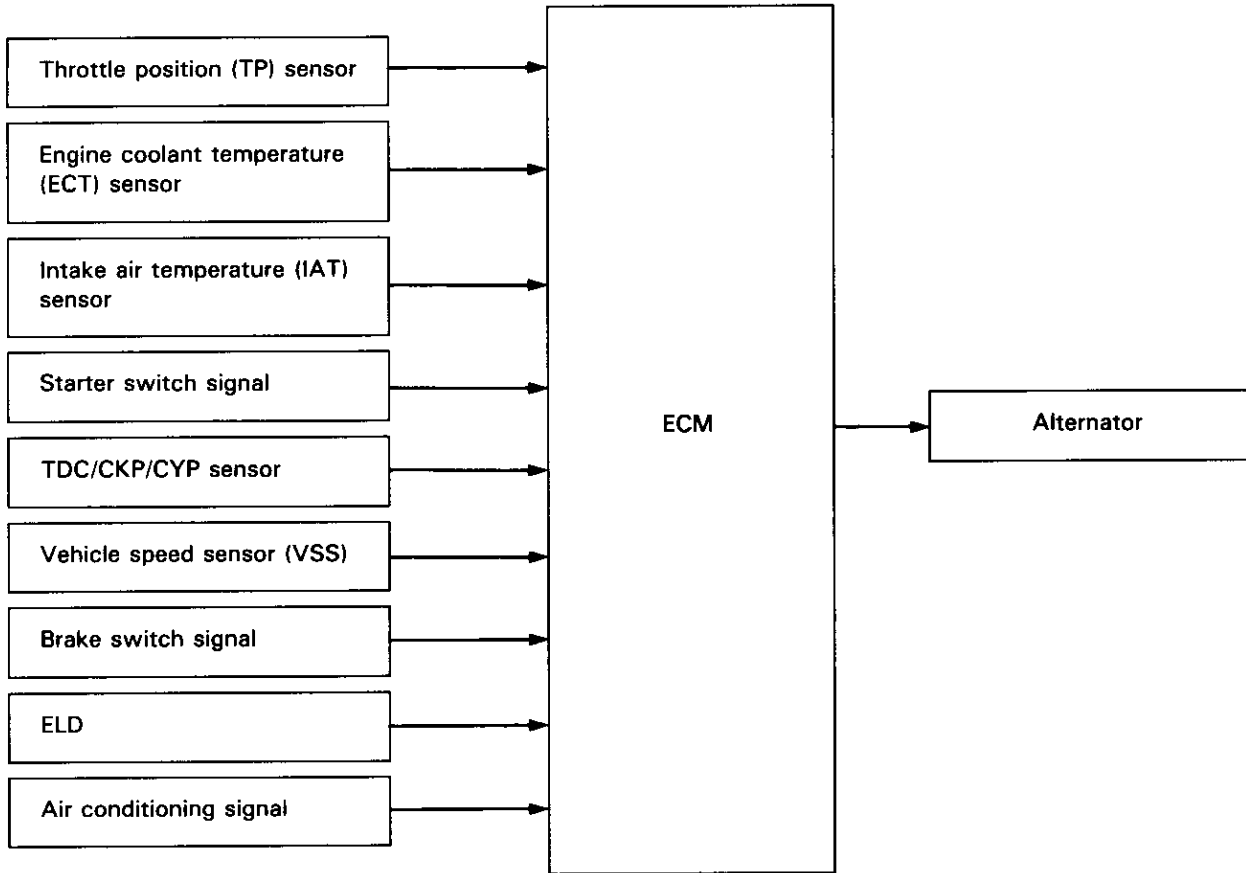

Charging System

Circuit Diagram

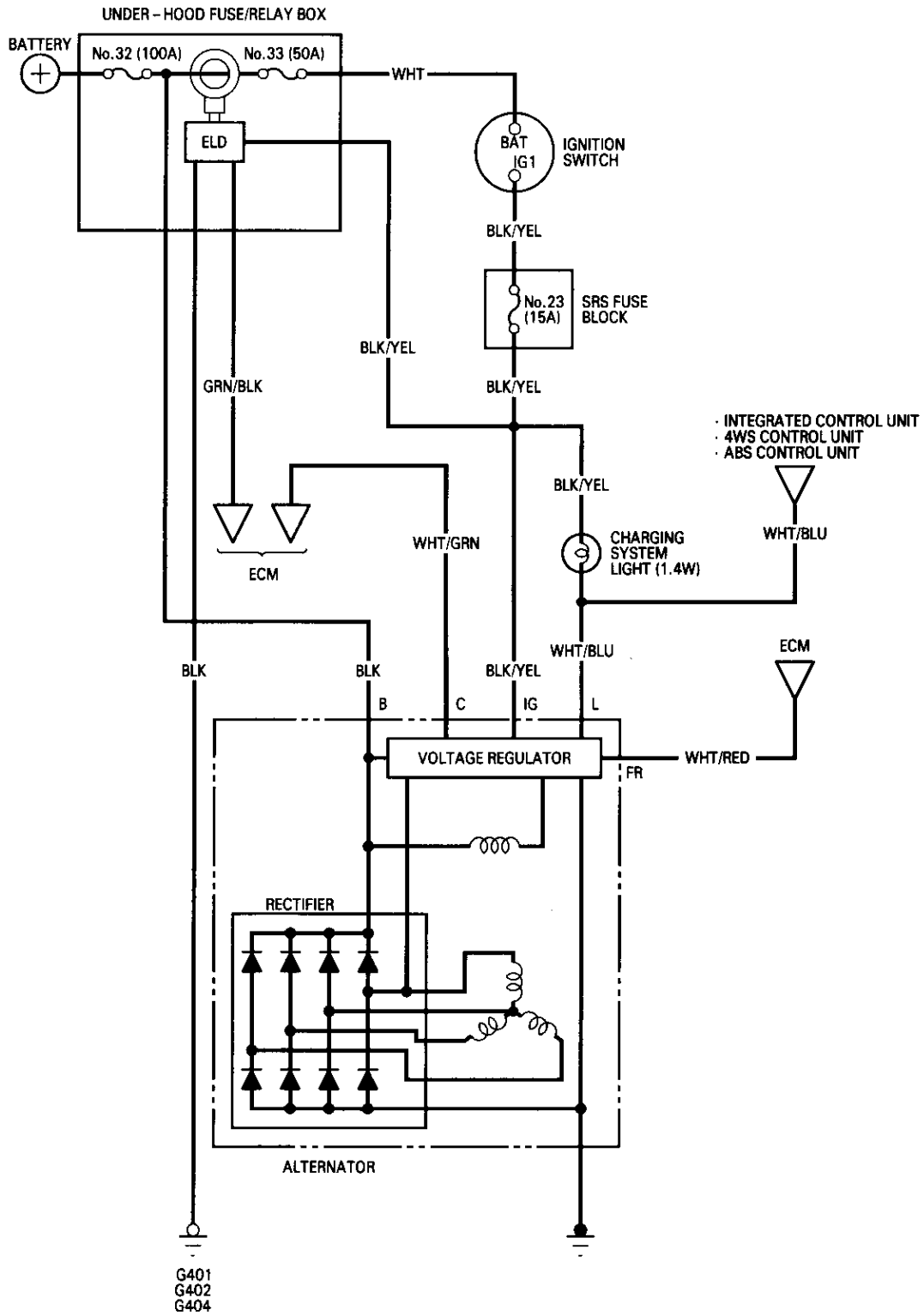



Troubleshooting

If the charging system light is on, or the battery is dead or low, test the following items in the order listed below:

1. Battery (see page 23-66)
2. Charging System Light
3. Alternator/Regulator

Charging System Light Test

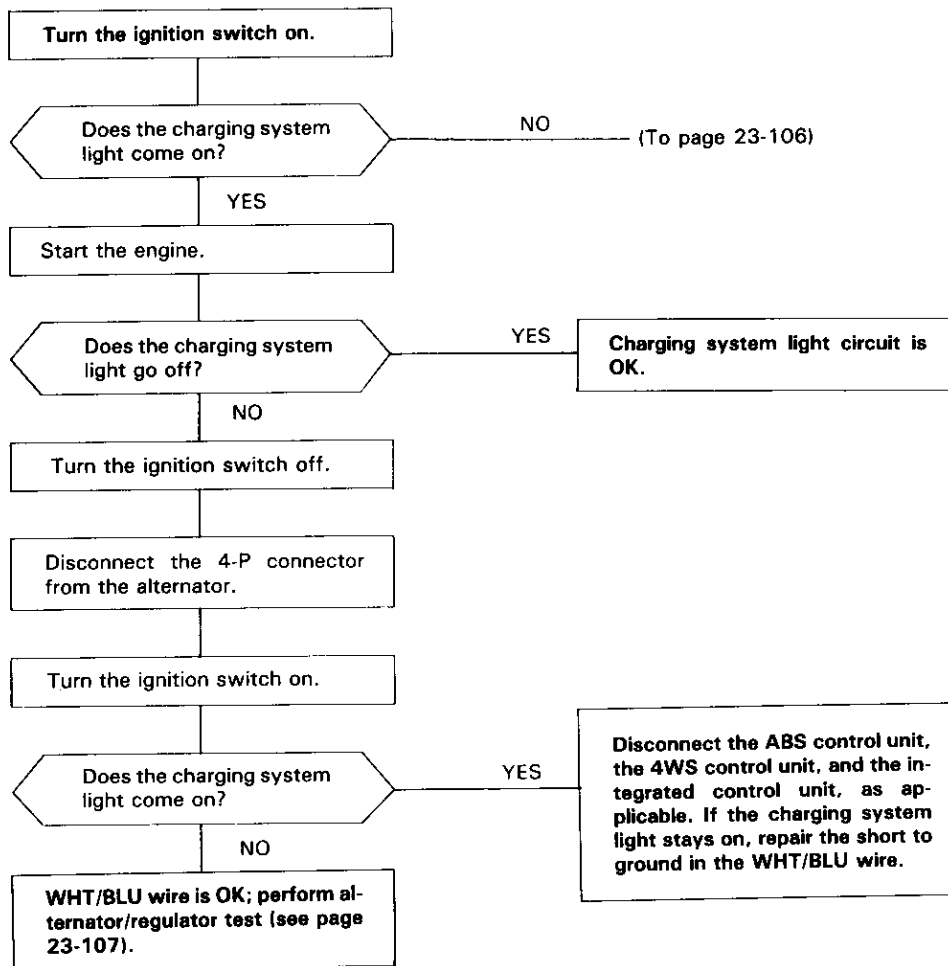

(cont'd)

Charging System

Troubleshooting (cont'd)

(From page 23-105)

Turn the ignition switch off.

Check fuse No. 23 (15 A) in the under-dash fuse/relay box.

Is the fuse OK?

NO

Replace the fuse.

YES

Disconnect the 4-P connector from the alternator.

Turn the ignition switch on.

Check for voltage at the IG (BLK/YEL wire) terminal of the 4-P connector.

4-P CONNECTOR

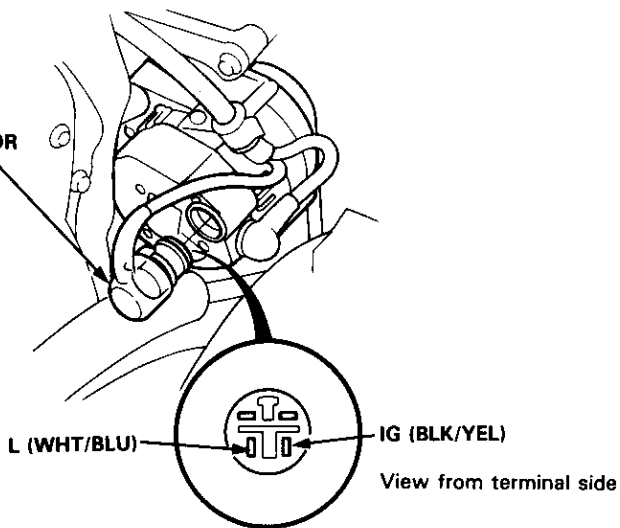

View from terminal side

Is there battery voltage?

NO

Repair open in the BLK/YEL wire.

YES

Ground the WHT/BLU wire at the L terminal of the 4-P connector.

Does the charging system light come on?

NO

Check for a blown charging system light bulb. If the bulb is OK, repair open in the WHT/BLU wire.

YES

Replace the voltage regulator.



Alternator/Regulator Test

NOTE: Be sure the battery is sufficiently charged (see page 23-66).

Connect the Sun VAT-40 (or equivalent tester) and turn the selector switch to position 1 (starting).

Start the engine and let it idle until it reaches normal operating temperature (the radiator fan comes on).

Raise the engine speed to 2000 rpm and hold it there.

Is the voltage over 15.1 V?
YES
NO

Release the accelerator pedal and let the engine idle.

Make sure all accessories are turned off. Turn the selector switch to position 2 (charging).

Remove the inductive pick-up and zero the ammeter.

Place the inductive pick-up over the negative battery cable so that the arrow points away from the battery.

Raise the engine speed to 2000 rpm and hold it there.

Is the voltage less than 13.9 V?
NO
YES

Replace the voltage regulator.

Test the battery (see page 23-66).

(To page 23-108)

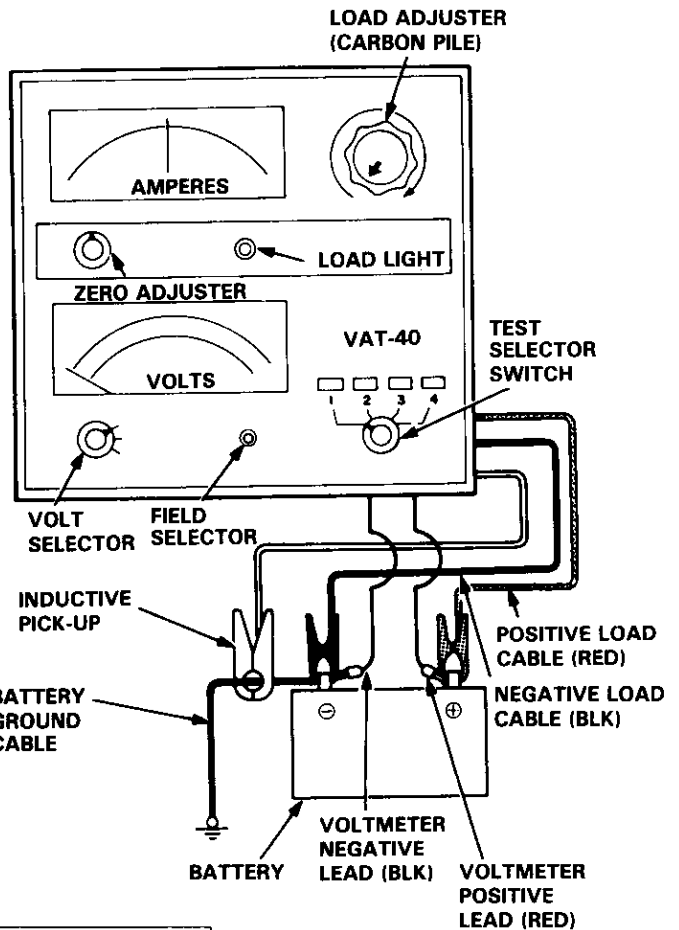

(cont'd)

Charging System

Troubleshooting (cont'd)

(From page 23-107)

Apply a load with the VAT-40 until the battery voltage drops to between 12–13.5 V.

Is the amperage *A or more?

YES

Charging system is OK.

NO

With the engine speed still at 2000 rpm, full-field the alternator.

CAUTION: The voltage will rise quickly when the alternator is full-fielded. Do not allow the voltage to exceed 18 V; it may damage the electrical system.

NOTE: Attach a probe to the VAT-40 full-field test lead and insert the probe into the full-field access hole at the back of the alternator. Switch the field selector to "A (Ground)" position momentarily and check the amperage reading.

*A: F22A1 engine (55A)
H22A1 engine (65A)
H23A1 engine (60A)

Is the alternator output *A or more?

NO

Test and repair the alternator components.

YES

Turn the ignition switch off; then turn it on again.

Disconnect the 4-P connector from the alternator.

Check for voltage at the IG (BLK/YEL wire) terminal of the 4-P connector.

Is there battery voltage?

NO

Repair open in the BLK/YEL wire.

YES

Replace the voltage regulator.

FULL FIELD ACCESS HOLE

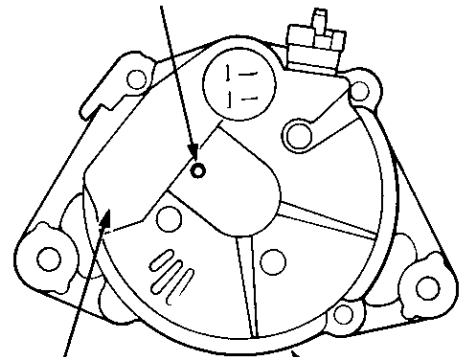

REGULATOR
Located inside
the end cover

END COVER

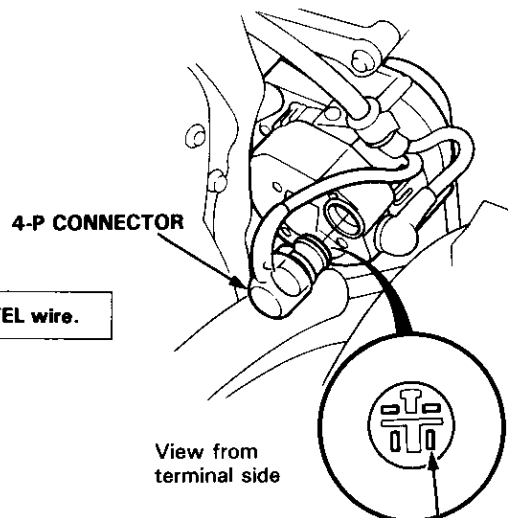

4-P CONNECTOR

View from
terminal side

IG (BLK/YEL)



Alternator Replacement

1. Remove the power steering pump (see section 17) and the cruise control actuator (see page 23-284).

NOTE: Do not disconnect the actuator cable.

2. Disconnect the 4-P connector from the alternator.
3. Remove the terminal nut and the BLK wire from the B terminal.

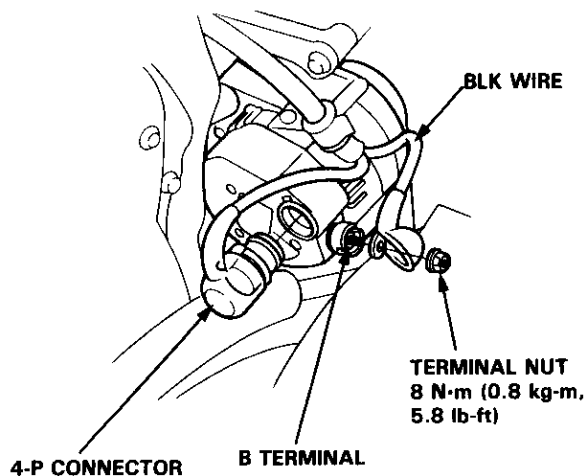

4. Loosen the through bolt, then loosen the adjustment locknut, and then the adjusting bolt.
5. Remove the belt from the alternator.
6. Remove the adjustment bolt and nut.
7. Remove the through bolt, then remove the alternator.

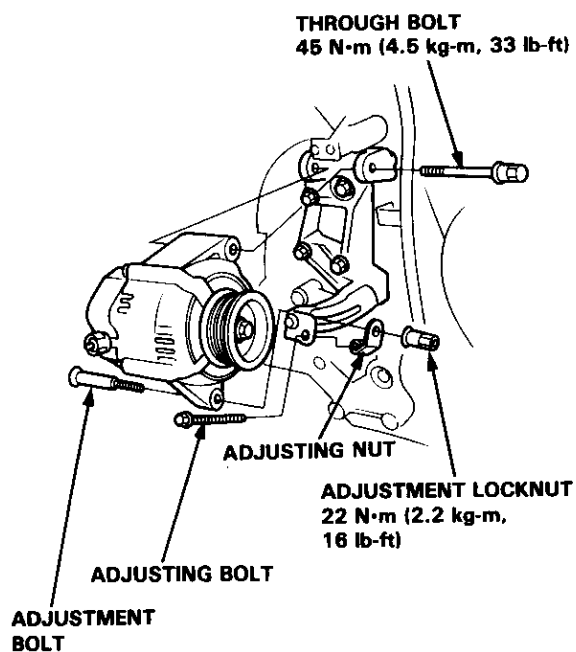

8. After installing the alternator, adjust the alternator belt tension (see page 23-113).

Charging System

Alternator Overhaul

NOTE: It is only necessary to separate the pulley, drive-end housing, and rotor when the front bearing needs replacement.

Loosen the locknut with 10 mm and 22 mm wrenches to remove the pulley from the rotor. If necessary, use an impact wrench.

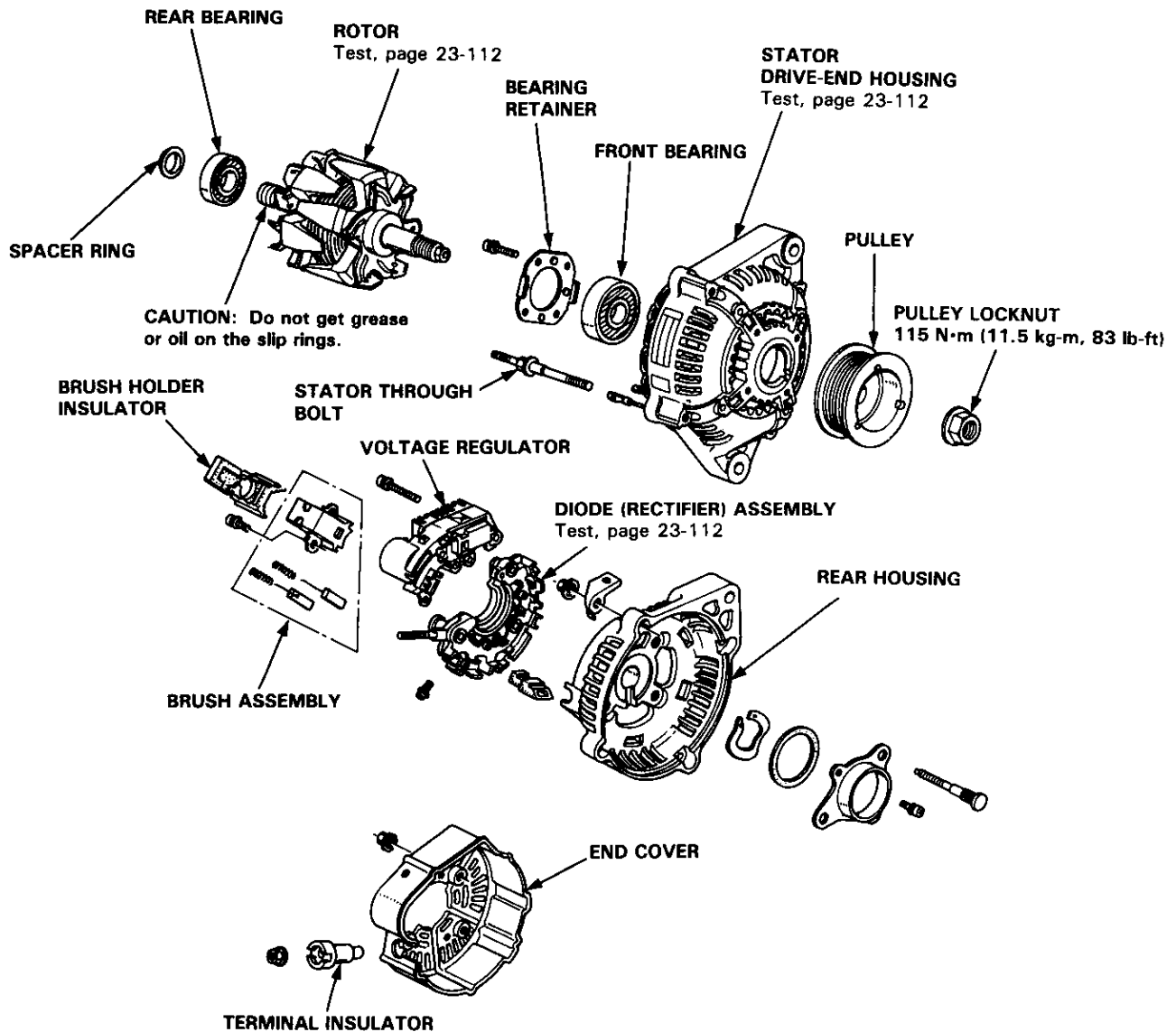
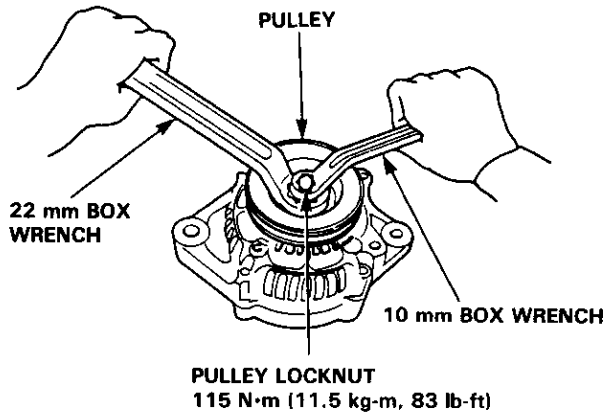



Rectifier Test

NOTE: The diodes are designed to allow current to pass in one direction while blocking it in the opposite direction. Since the alternator rectifier is made up of eight diodes (four pairs), each diode must be tested for continuity in both directions with an ohmmeter that has diode checking capability; a total of 16 checks.

1. Check for continuity in each direction, between the B and P, and between the E (ground) and P terminals of each diode pair. All diodes should have continuity in only one direction.

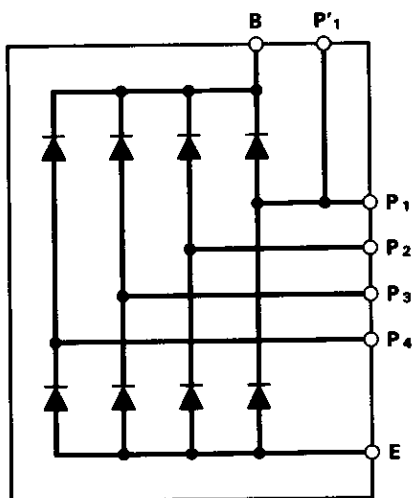
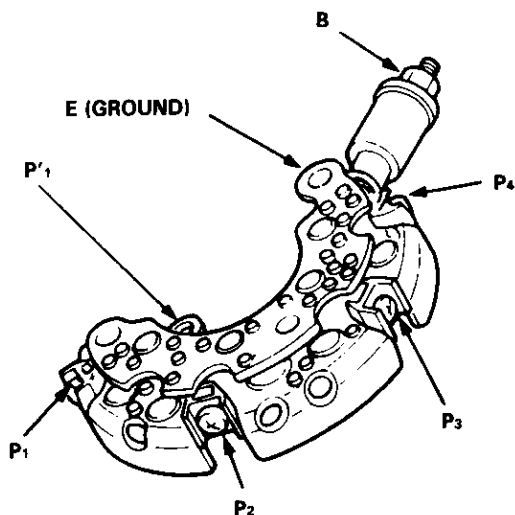

2. If any of the eight diodes fails, replace the rectifier assembly. (Diodes are not available separately.)

Alternator Brush Inspection

1. Remove the end cover, then take out the brush holder by removing its two screws.
2. Measure the length of the brushes with a vernier caliper.

Alternator Brush Length:

Standard: 10.5 mm (0.41 in)

Service Limit: 1.5 mm (0.06 in)

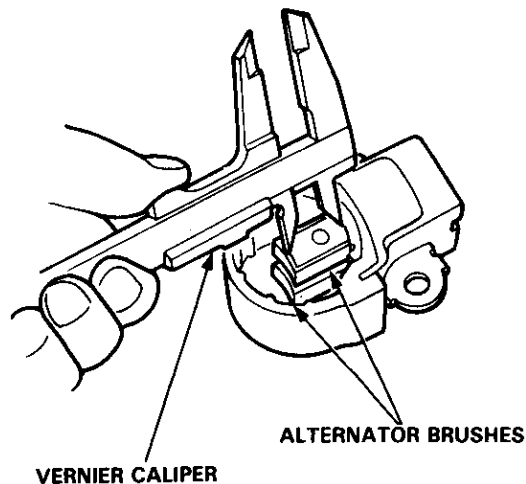

If the brushes are less than the service limit, replace the alternator brush assembly.

Charging System

Rotor Slip Ring Test

1. Check that there is continuity between the slip rings.

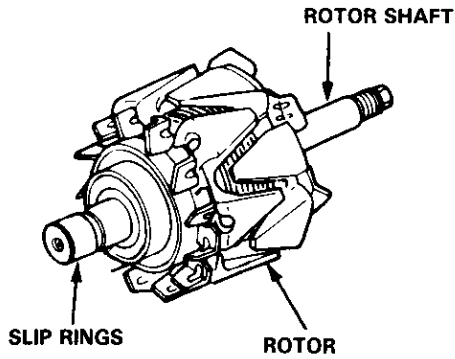

2. Check that there is no continuity between the slip rings and the rotor or rotor shaft.
3. If the rotor fails either continuity check, replace the alternator.

Stator Test

1. Check that there is continuity between each pair of leads.

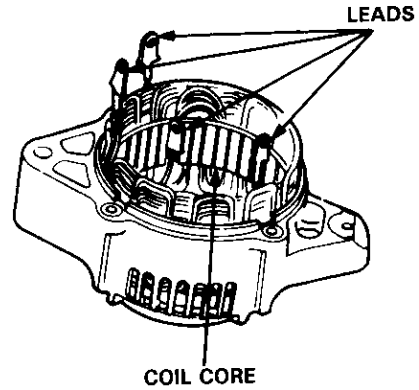

2. Check that there is no continuity between each lead and the coil core.
3. If the coil fails either continuity check, replace the alternator.



Alternator Belt Adjustment (Without A/C)

Deflection Method:

1. Apply a force of 100 N (10 kg, 22 lbs) and measure the deflection between the alternator and the crankshaft pulley.

Deflection: 10.5–12.5 mm (0.42–0.51 in)

NOTE: On a brand-new belt (one that has been run for less than five minutes), the deflection should be 8–10 mm (0.32–0.40 in) when first measured. If the belt is worn or damaged, replace it.

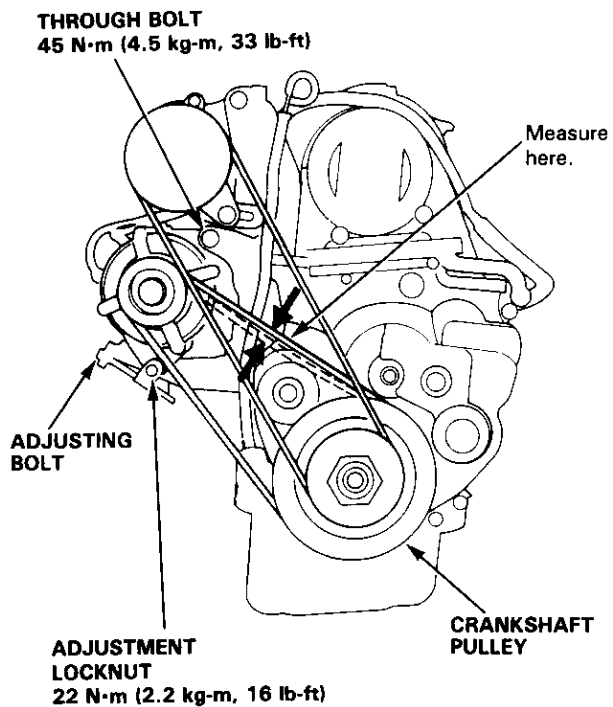

2. Loosen the through bolt and adjustment locknut.
3. Turn the adjusting bolt to obtain the proper belt tension, then retighten the nut and through bolt.
4. Recheck the belt deflection.

NOTE: Install and adjust the power steering pump belt (see section 17).

Belt Tension Gauge Method:

1. Following the gauge manufacturer's instructions, attach the belt tension gauge to the belt and measure the tension.

Tension: 300–450 N (30–45 kg, 66–99 lbs)

NOTE: On a brand-new belt (one that has been run for less than five minutes), the tension should be 450–650 N (45–65 kg, 99–143 lbs) when first measured. If the belt is worn or damaged, replace it.

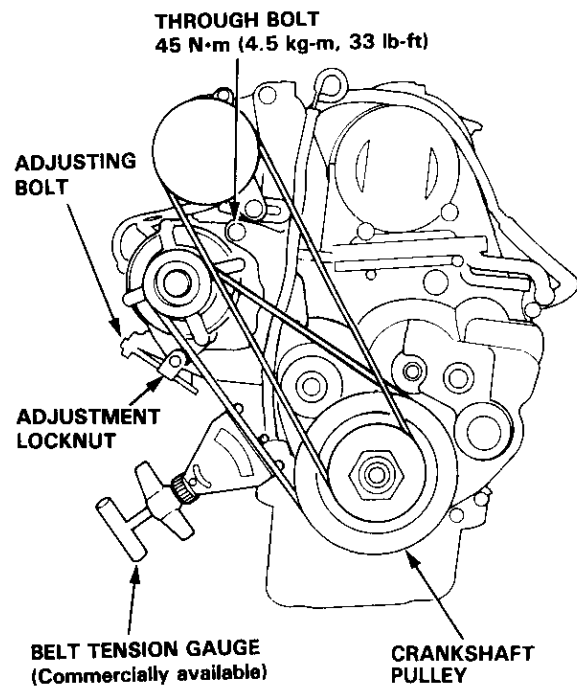

2. Loosen the through bolt and adjustment locknut.
3. Turn the adjusting bolt to obtain the proper belt tension, then retighten the nut and through bolt.
4. Recheck the tension of the belt.

NOTE: Install and adjust the power steering pump belt (see section 17).

Charging System

Alternator Belt Adjustment (With A/C)

Deflection Method:

- 1 Apply a force of 100 N (10 kg, 22 lbs) and measure the deflection between the alternator and the crankshaft pulley.

Deflection: 10–12 mm (0.39–0.47 in)

NOTE:

- On a brand-new belt (one that has been run for less than five minutes), the deflection should be 5.5–7.5 mm (0.22–0.30 in) when first measured.
- If there are cracks or any damage evident on the belt, replace it with a new one.

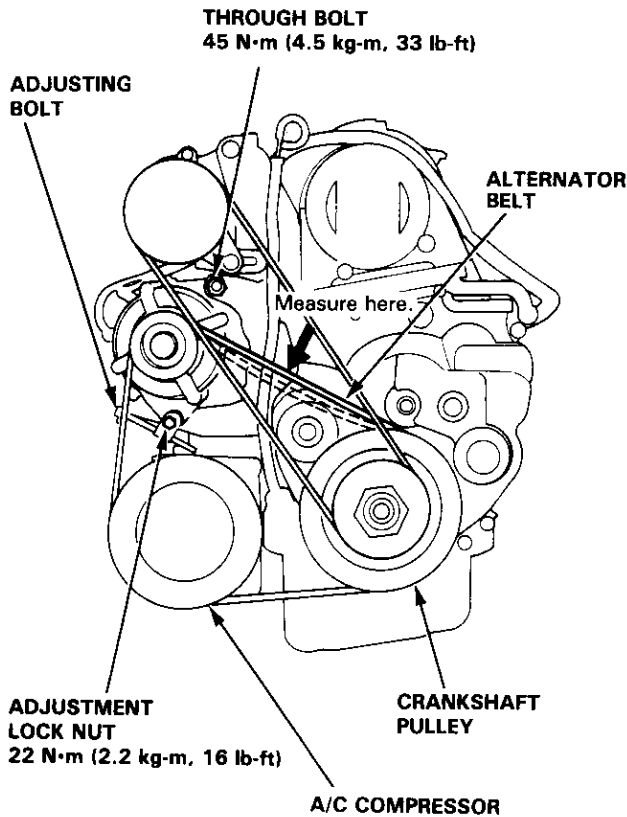

2. Loosen the through bolt and adjustment locknut.
3. Turn the adjusting bolt to obtain the proper belt tension, then retighten the nut and through bolt.
4. Recheck the belt deflection.

NOTE: Install and adjust the power steering pump belt (see section 17).

Belt Tension Gauge Method:

1. Attach the belt tension gauge to the belt and measure the tension of the belt.

Tension: 450–600 N (45–60 kg, 99–132 lbs)

NOTE:

- On a brand-new belt (one that has been run for less than five minutes), the tension should be 950–1050 N (95–105 kg, 209–231 lbs) when first measured.
- Follow the manufacturer's instructions for the belt tension gauge.
- If there are cracks or any damage evident on the belt, replace it with a new one.

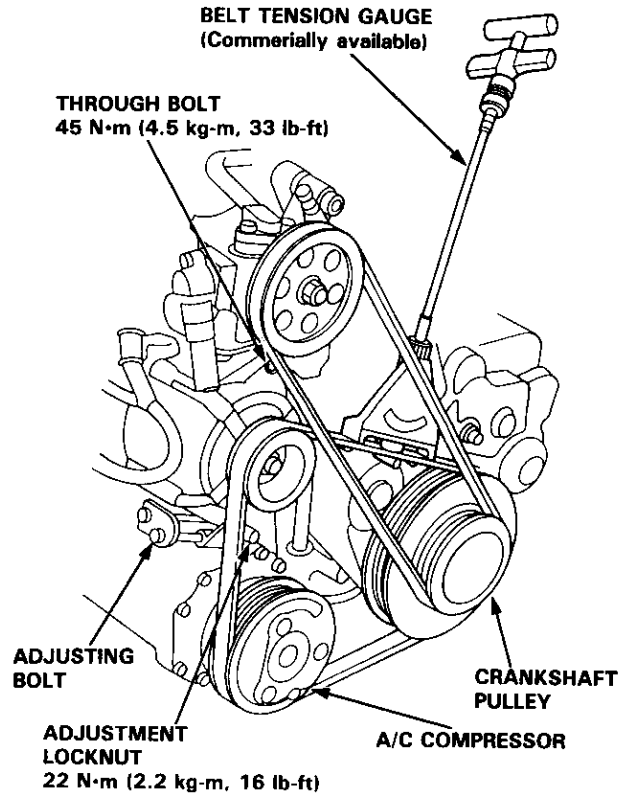

2. Loosen the through bolt and adjustment locknut.
3. Turn the adjusting bolt to obtain the proper belt tension, then retighten the nut and through bolt.
4. Recheck the tension of the belt.

NOTE: Install and adjust the power steering pump belt (see section 17).



Radiator and Condenser Fan Controls

Component Location Index

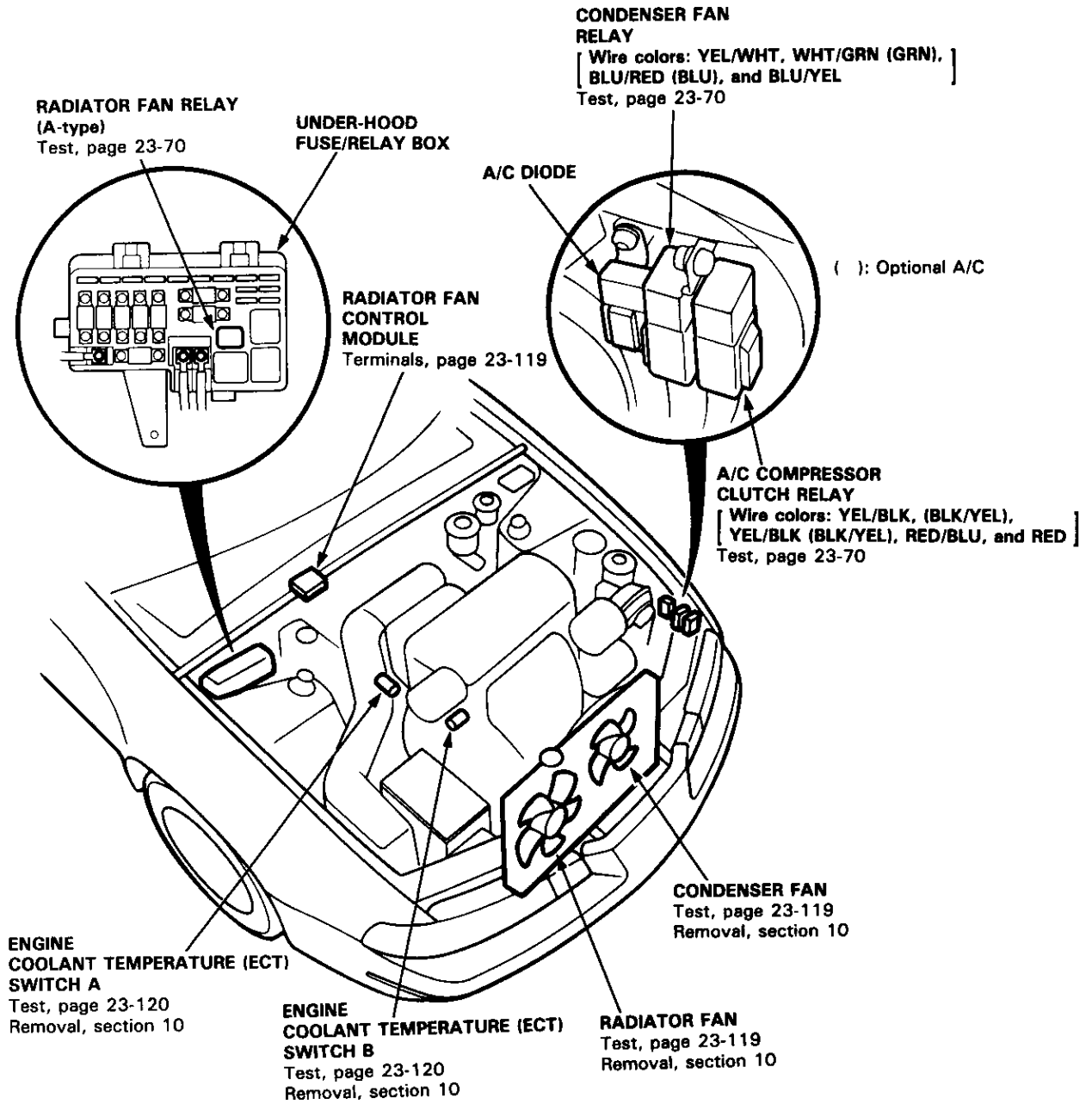

Radiator Fan Control:

When the engine coolant temperature is above approximately 223 °F (106 °C) after the engine has stopped, the radiator fan will run for about 15 minutes. Engine coolant temperature (ECT) switch A is in the thermostat housing. ECT switch B is located behind the water outlet housing. The radiator fan control module is located on the right side of the front floor, under the carpet.

Radiator and Condenser Fan Controls

Circuit Diagram (With A/C)

NOTE: Different wires with the same color have been given a number suffix to distinguish them (for example, YEL¹ and YEL² are not the same).

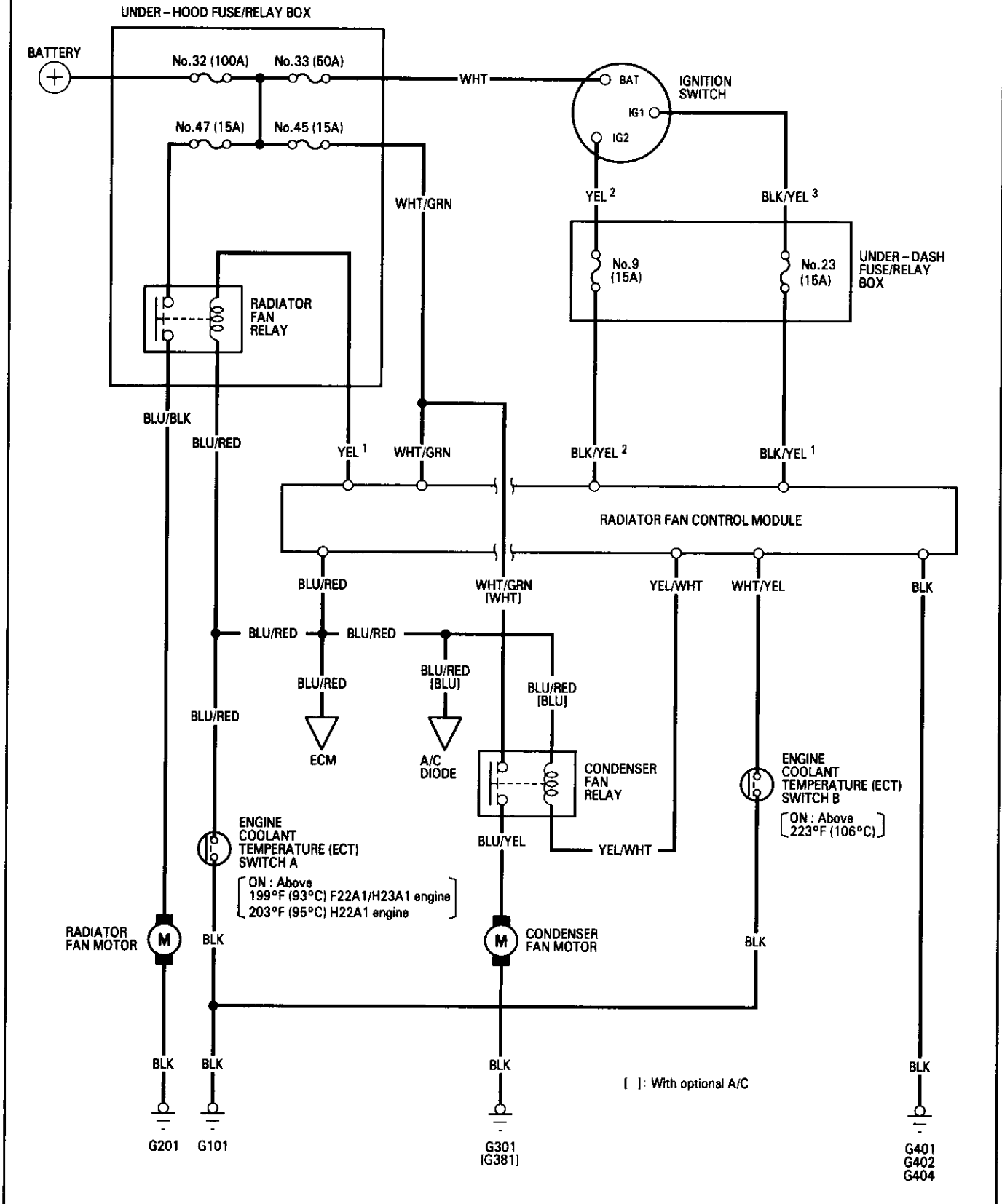



Circuit Diagram (Without A/C)

NOTE: Different wires with the same color have been given a number suffix to distinguish them (for example, YEL¹ and YEL² are not the same).

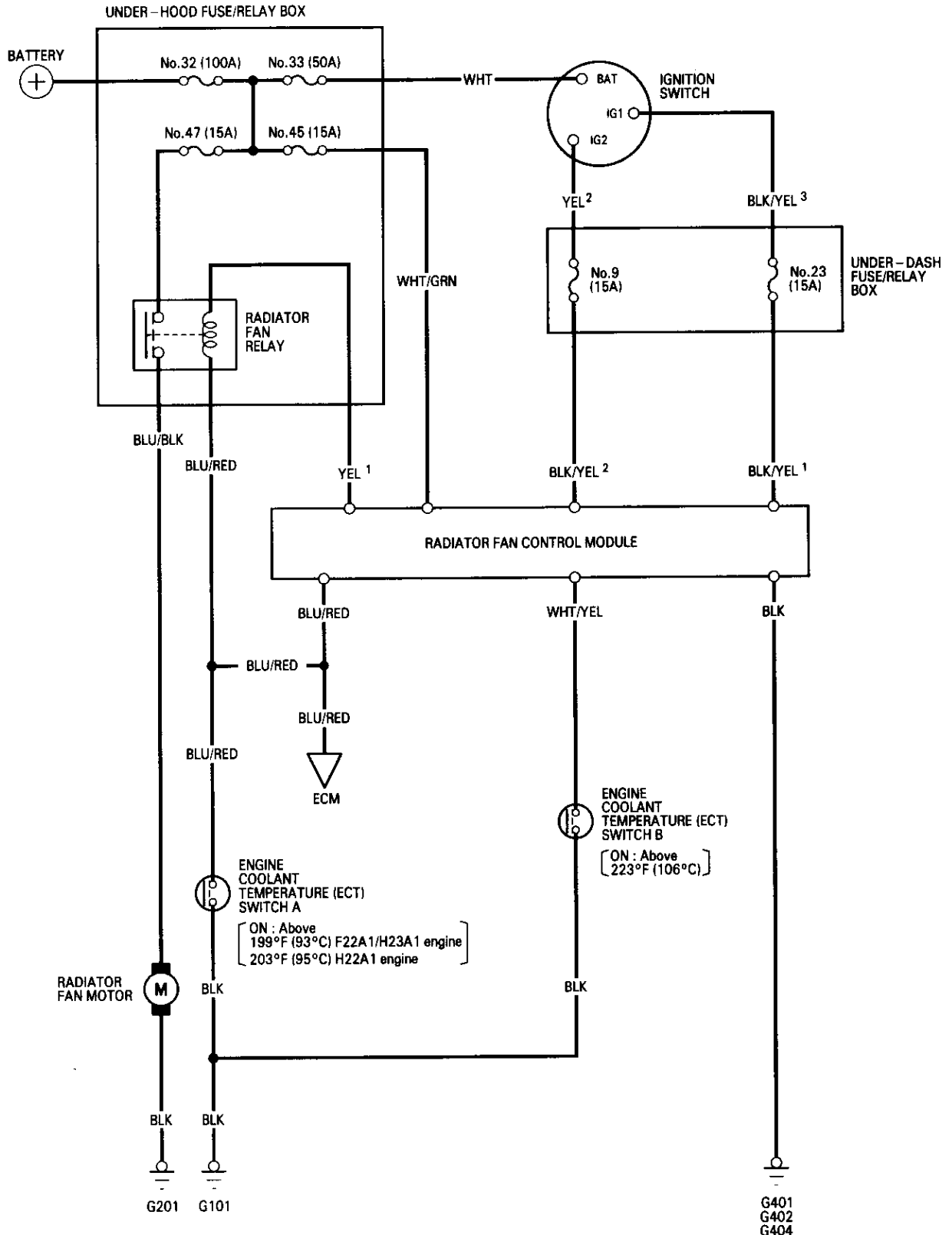

Radiator and Condenser Fan Controls

Troubleshooting

NOTE: The numbers in the table show the troubleshooting sequence.

Item to be inspected		Blown No. 47 (15 A) fuse (In the under-hood fuse/relay box)	Blown No. 45 (15 A) fuse (In the under-hood fuse/relay box)	Blown No. 23 (15 A) fuse (In the under-dash fuse/relay box)	Blown No. 9 (15 A) fuse (In the under-dash fuse/relay box)	Radiator fan or condenser fan relay	Radiator fan or condenser fan motor	Engine coolant temperature (ECT) switch A	Engine coolant temperature (ECT) switch B	Faulty radiator fan control module	A/C system	Poor ground	Open circuit, loose or disconnected terminals
Symptom													
Only one fan runs (with engine running and A/C ON).		1				2	3					G201 G301 (G381)	WHT/GRN (WHT/, BLU/BK, BLI/YEL, YEL ¹ , YEL/WHT or BLU/RED (BLU)
Fans do not run.	Under all conditions.				1			2	3	4		G101 G401 G402 G404	BLK/YEL ² , BLU/RED or WHT/YEL
	A/C ON										1		
Radiator fan control module fails to function properly.			1	2					3	4		G101 G401 G402 G404	WHT/GRN, BLK/YEL ¹ , WHT/YEL or YEL ¹

(): With optional A/C



Radiator Fan Control Module

Terminals

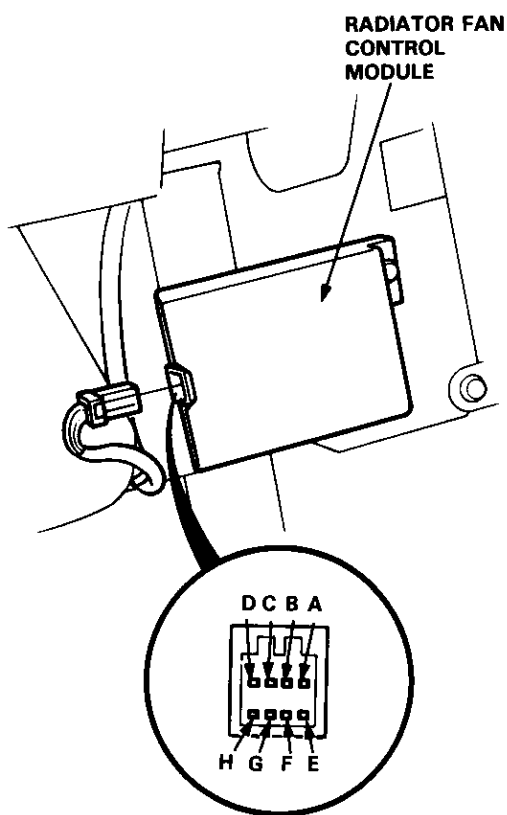

NOTE: See section 22 for the input test.

Terminal	Wire	Connects to
A	BLK	Ground (G401, G402, G404)
B	YEL/WHT	Condenser fan relay (Coil ⊕)
C	BLK/YEL	Power supply (For radiator fan and condenser fan relays via radiator fan control module with ignition switch ON)
D	YEL	Radiator fan relay (Coil ⊕)
E	BLU/RED	Radiator fan and condenser fan relays (Coil ⊖)
F	BLK/YEL	IG1 (Control module reset signal)
G	WHT/GRN	Power supply (For radiator fan control module with ignition switch OFF)
H	WHT/YEL	Engine coolant temperature (ECT) switch B

Fan Motor Test

1. Disconnect the 2-P connectors from each fan motor.

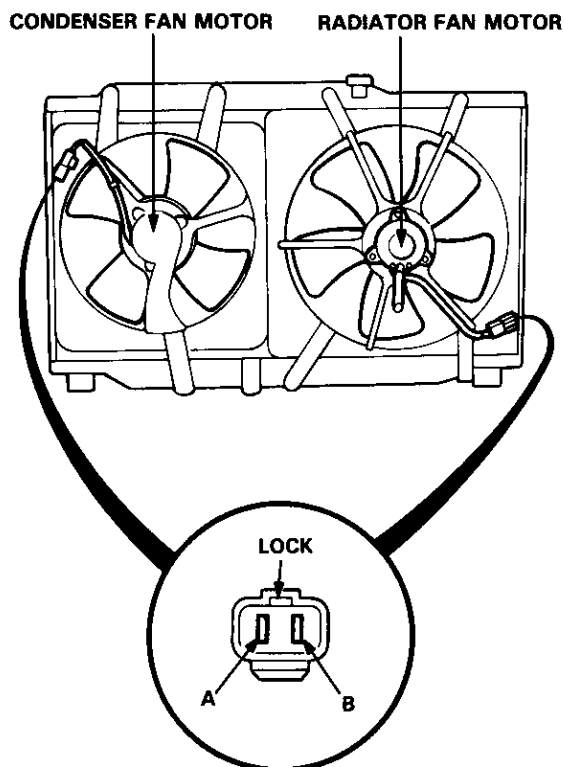

View from terminal side

2. Test the motor by connecting battery power to the A terminal, and ground to the B terminal.
3. If the motor fails to run or does not run smoothly, replace it.

Radiator and Condenser Fan Controls

Engine Coolant Temperature (ECT) Switch Test

NOTE: Bleed air from the cooling system after installing the engine coolant temperature (ECT) switch (see section 10).

1. Remove ECT switch A from the thermostat housing and ECT switch B from the water outlet housing.
2. Suspend each ECT switch in a container of water or engine oil as shown.

NOTE: The illustration shows ECT switch A.

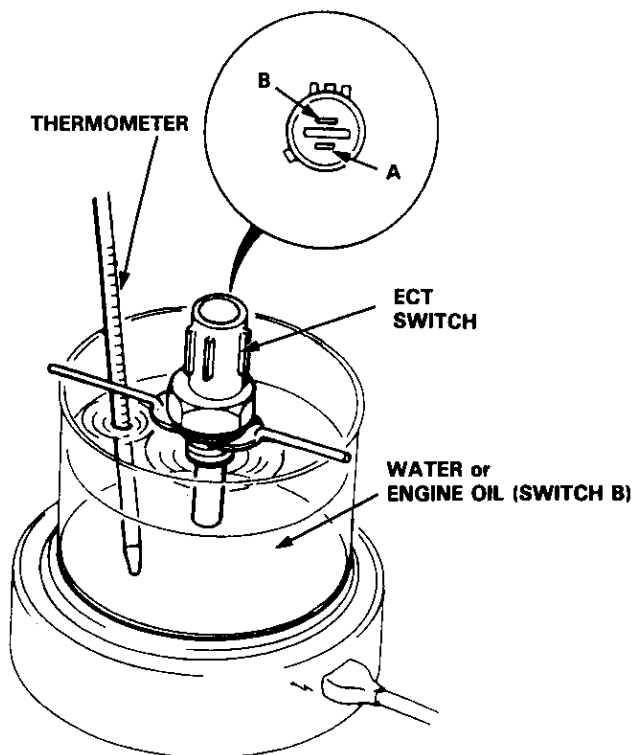

3. Heat the water or engine oil and check coolant temperature with a thermometer.
4. Check each ECT switch for continuity between the A and B terminals according to the table.

Operation		Temperature	Terminal	
			A	B
SWITCH A	ON	F22A1/H23A1 engine : { 194° - 205°F (90° - 96°C) H22A1 engine : { 198° - 208°F (92° - 98°C)	○	○
	OFF	35° - 44°F (2° - 7°C) lower than the temperature when it goes on.		
SWITCH B	ON	217° - 228°F (103° - 109°C)	○	○
	OFF	39° - 48°F (4° - 9°C) lower than the temperature when it goes on.		

Gauge Assembly

Component Location Index

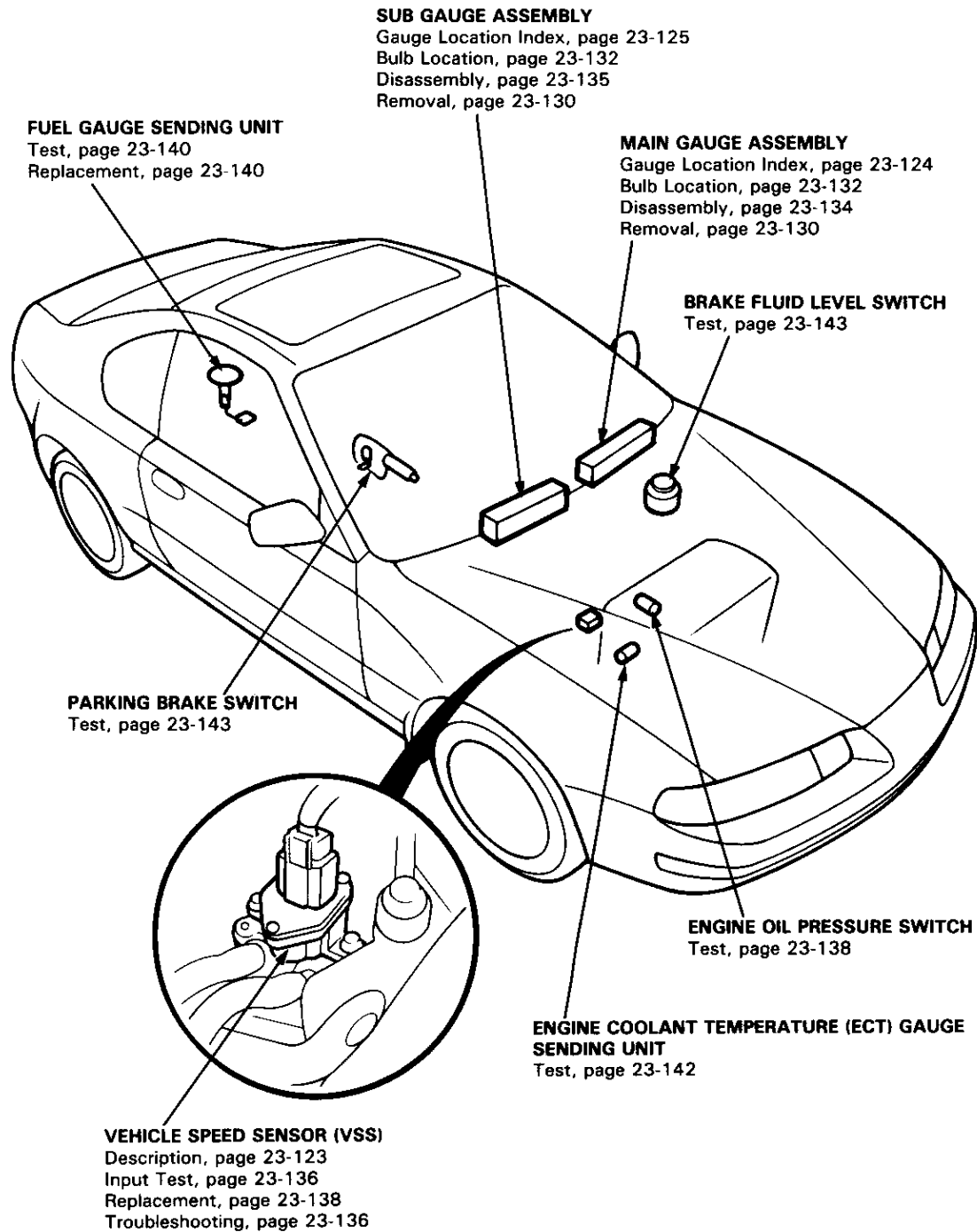



Description

Cableless Speedometer:

This consists of a newly developed electrical vehicle speed sensor (VSS), a control circuit, and bobbin-type movements to eliminate the engine noise transmitted by a cable, and the speed needle vibration caused by cable failure. This design is ideal for the limited space available.

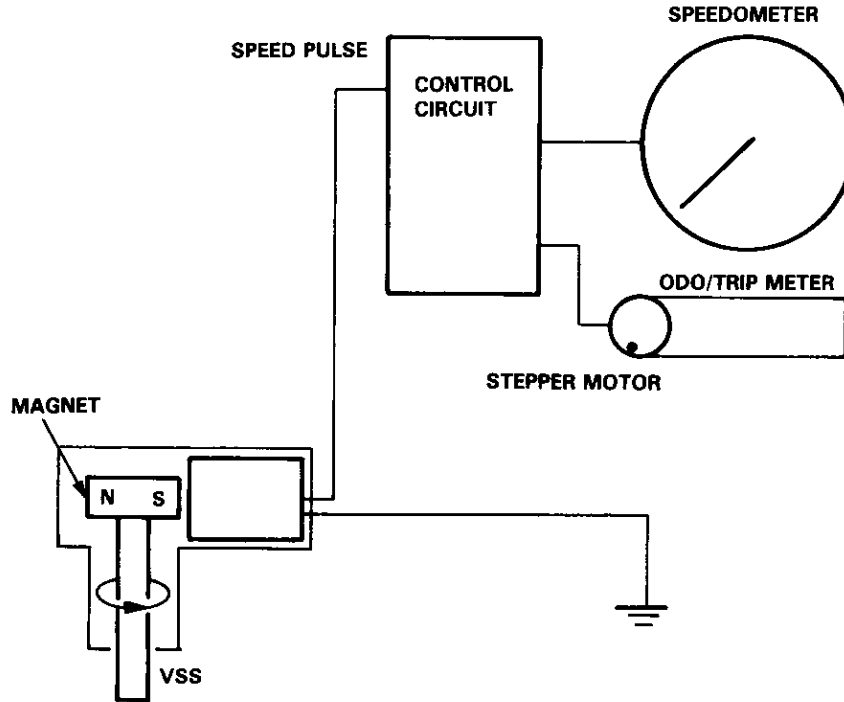

Engine Coolant Temperature (ECT) Gauge:

The gauge is divided into seven segments which light up in response to signals from the ECT gauge unit.

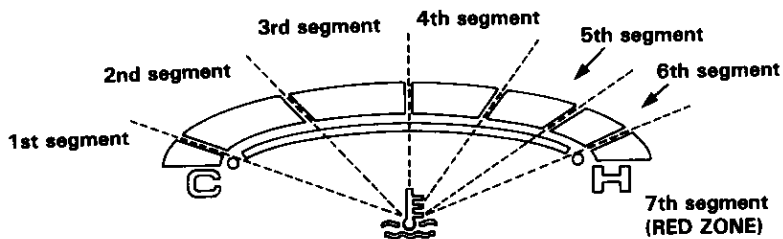

Fuel Gauge:

The gauge is divided into 20 segments which light up in response to signals from the fuel gauge unit.

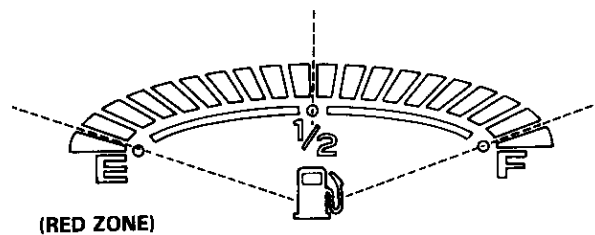

Gauge Assembly

Gauge/Terminal Locations Index

CAUTION:

- All SRS electrical wiring harnesses are covered with yellow outer insulation.
- Before disconnecting the SRS wire harness, install the short connector(s) on the airbag(s) (see page 23-294).
- Replace the entire affected SRS harness assembly if it has an open circuit or damaged wiring.
- After installing the gauge assembly, recheck the operation of the SRS indicator light.

NOTE: The radio may have a coded theft protection circuit. Be sure to get the customer's code number before

- Disconnecting the battery.
- Removing the No. 43 (10 A) fuse. (In the under-hood fuse/relay box)
- Removing the radio.

After service, reconnect power to the radio and turn it on. When the word "CODE" is displayed, enter the customer's 5-digit code to restore radio operation.

CONNECTOR "C" (Carries the SRS indicator signal)

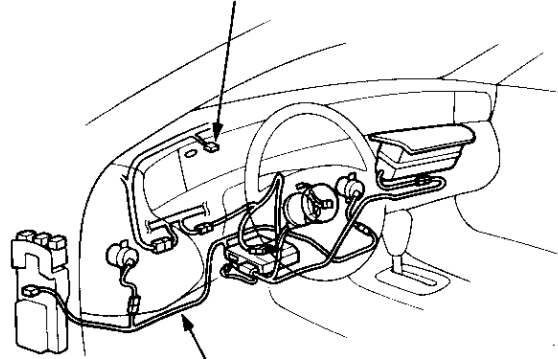

SRS MAIN HARNESS

Main Gauge Assembly:

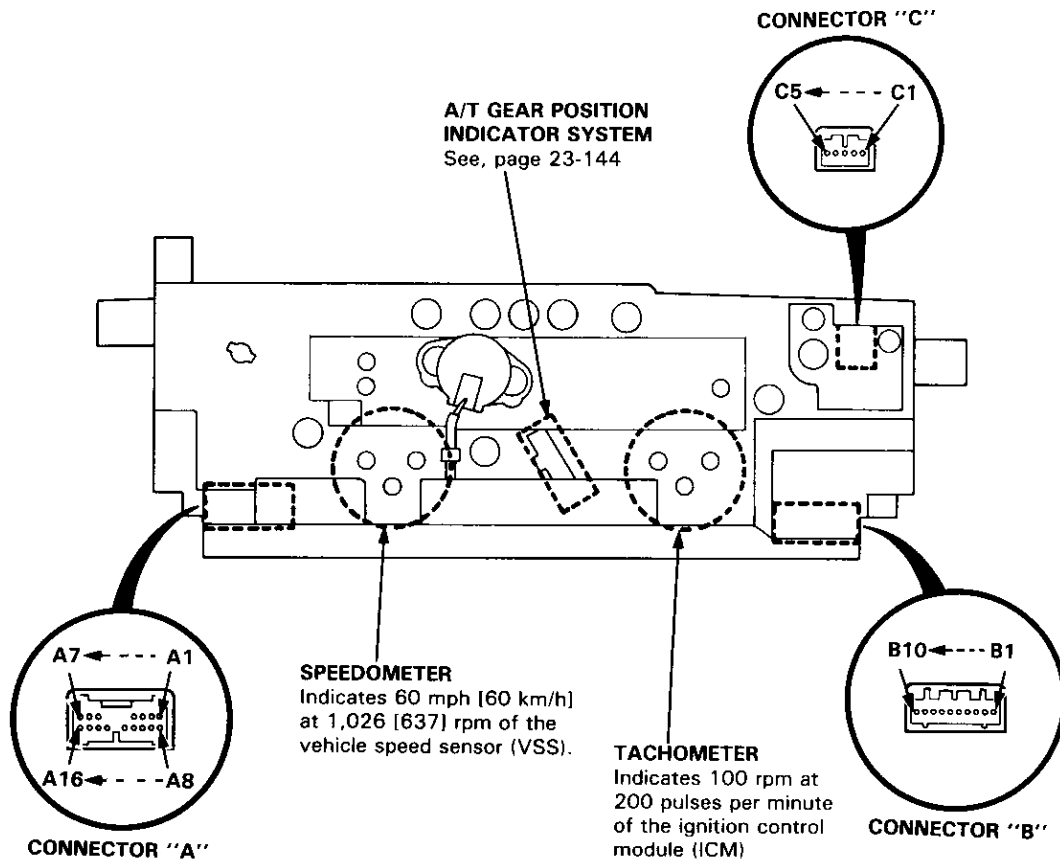



Sub Gauge Assembly:

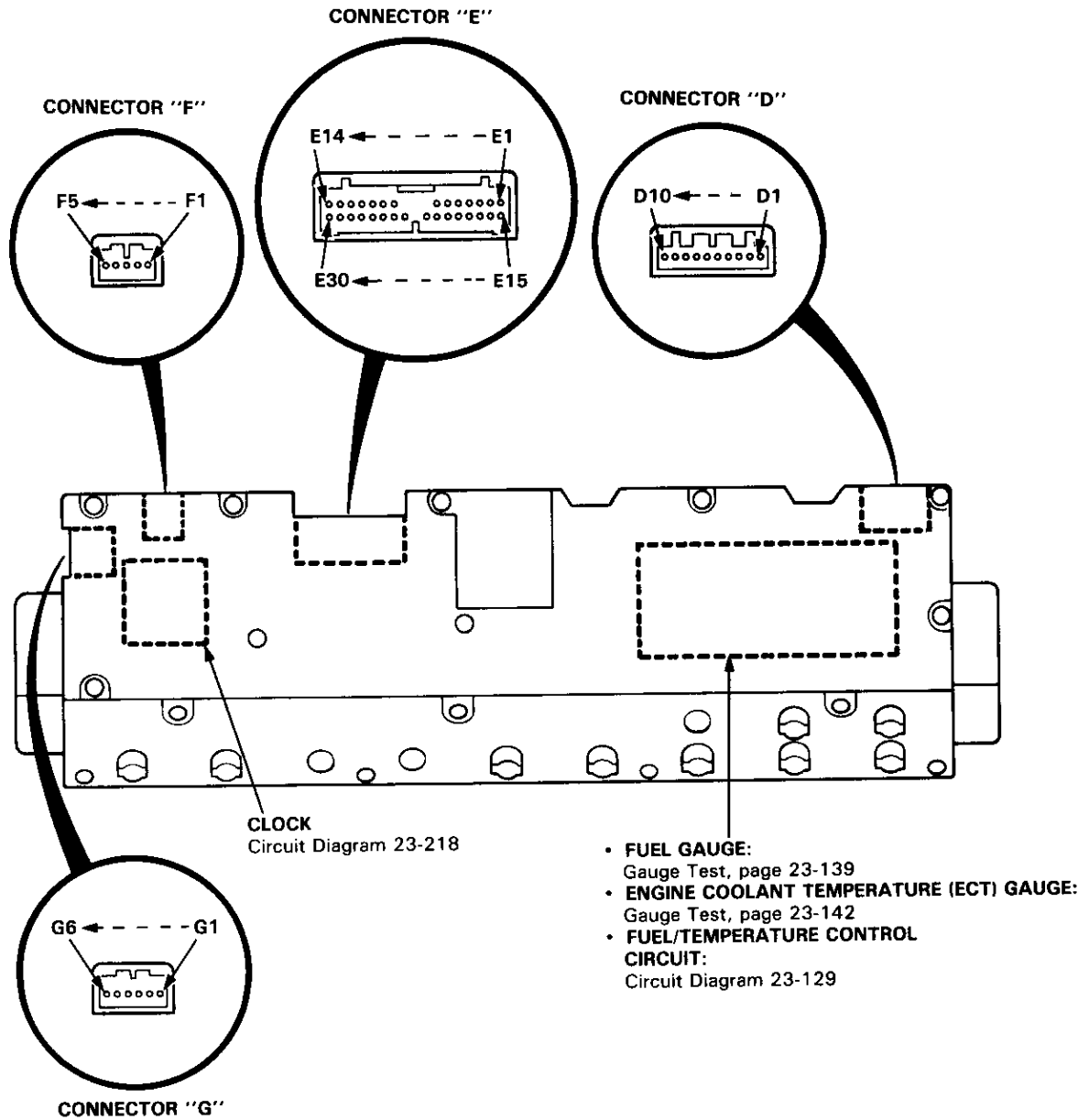

Gauge Assembly

Circuit Diagram

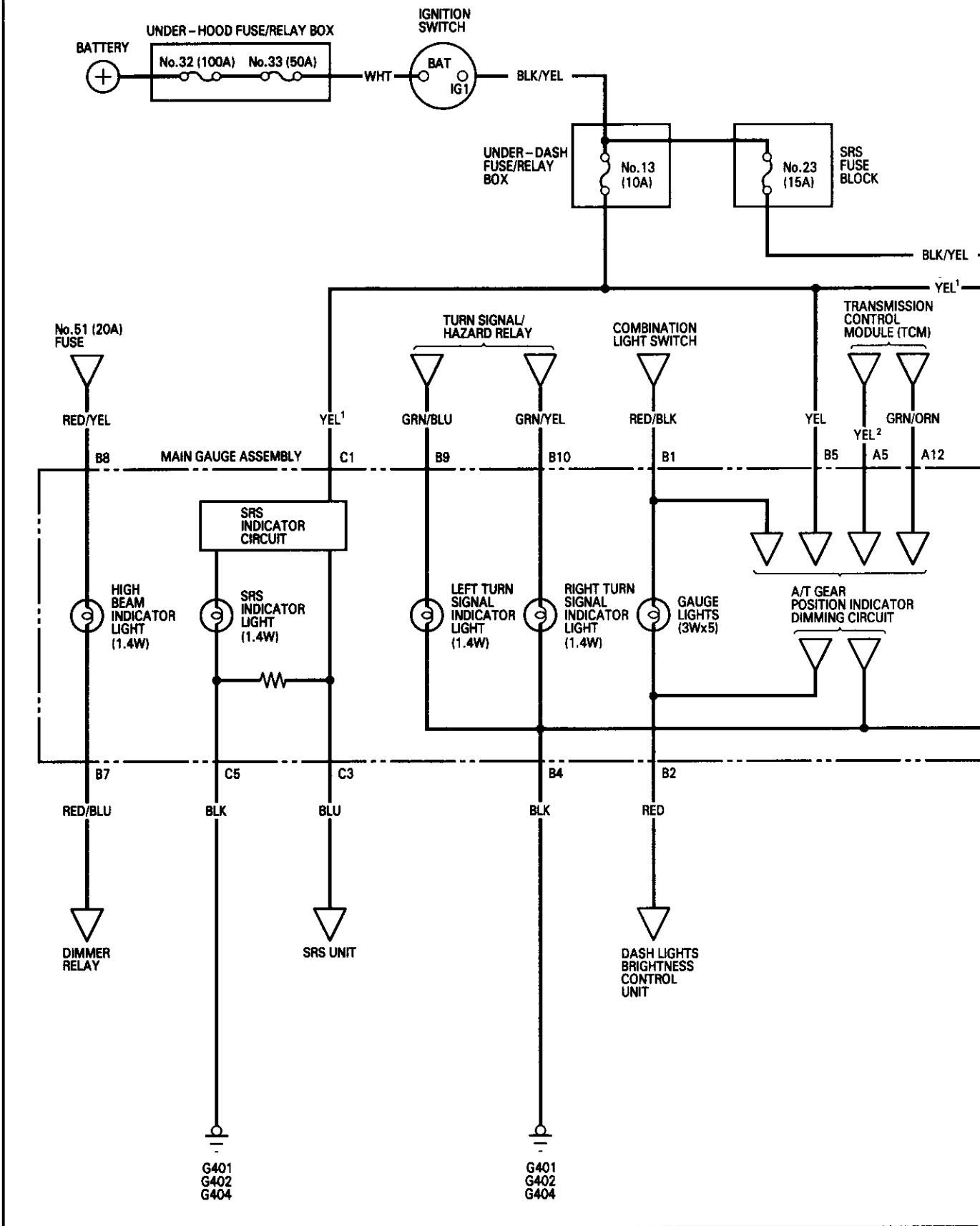

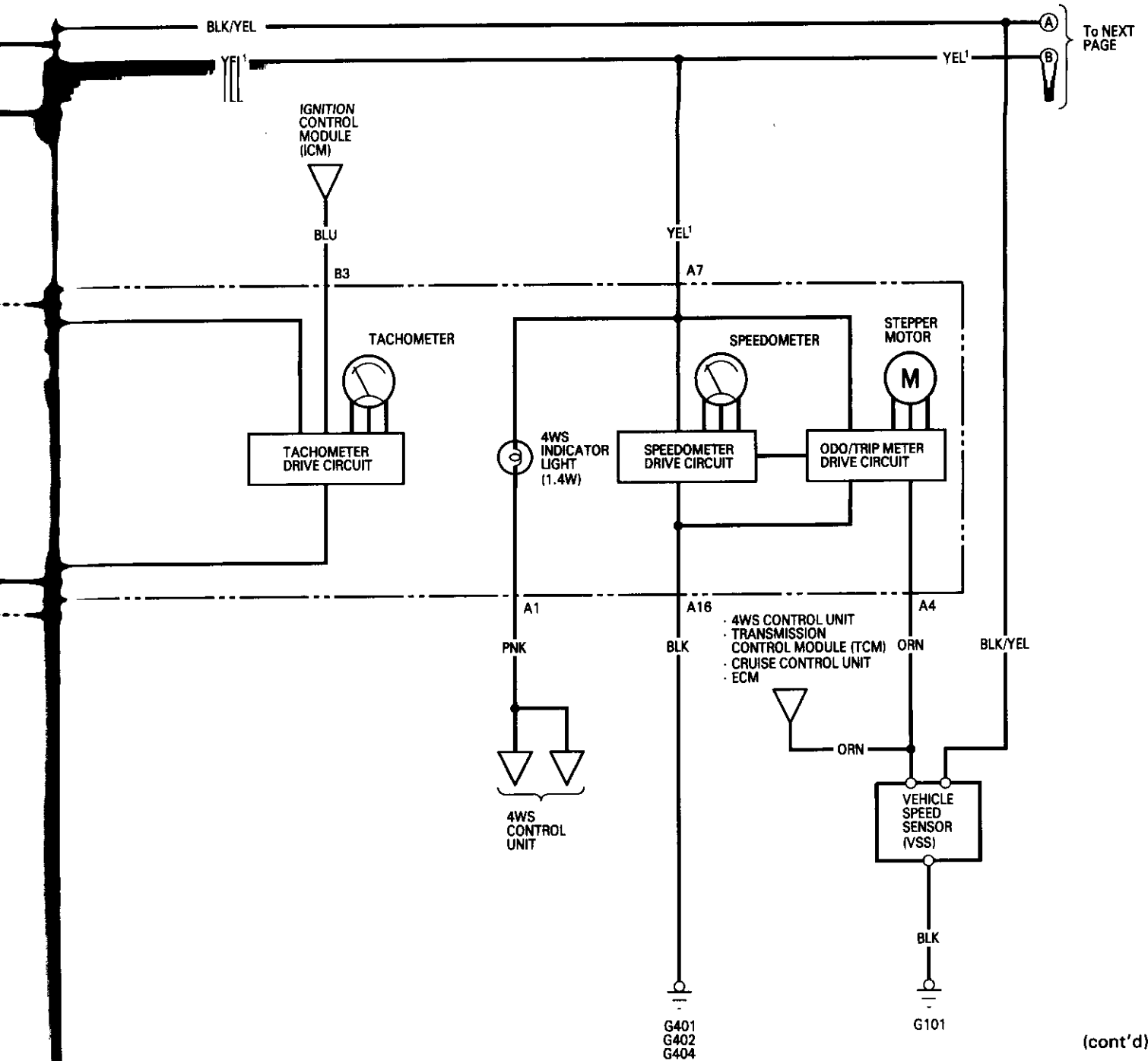

Gauge Assembly

Circuit Diagram (cont'd)

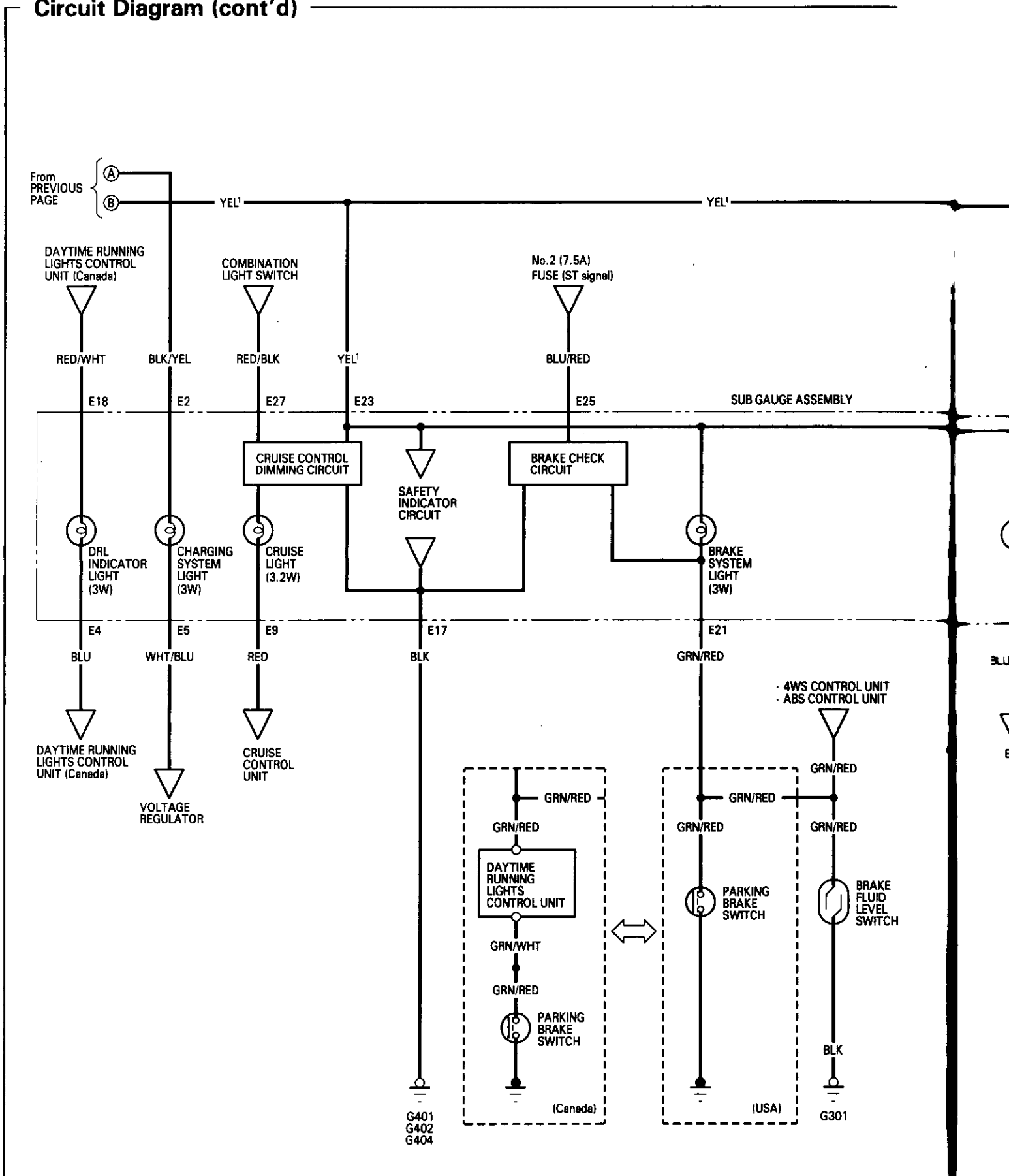

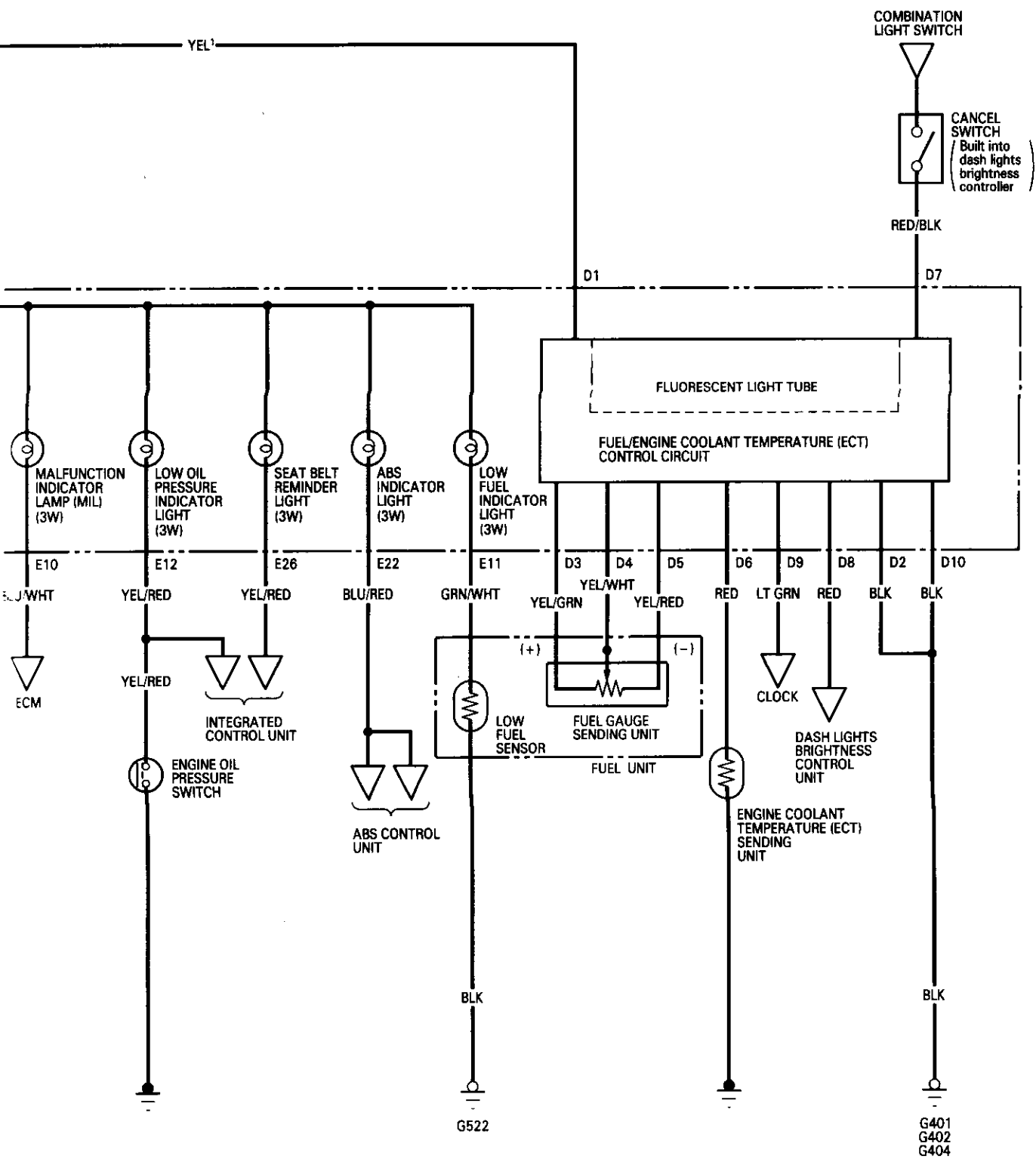

Gauge Assembly

Removal

CAUTION:

- All SRS electrical wiring harnesses are covered with yellow outer insulation.
- Before disconnecting the SRS wire harness, install the short connector(s) on the airbag(s) (see page 23-294).
- Replace the entire affected SRS harness assembly if it has an open circuit or damaged wiring.
- After installing the gauge assembly, recheck the operation of the SRS indicator light.

NOTE: The radio may have a coded theft protection circuit. Be sure to get the customer's code number before

- Disconnecting the battery.
- Removing the No. 43 (10 A) fuse. (In the under-hood fuse/relay box)
- Removing the radio.

After service, reconnect power to the radio and turn it on. When the word "CODE" is displayed, enter the customer's 5-digit code to restore radio operation.

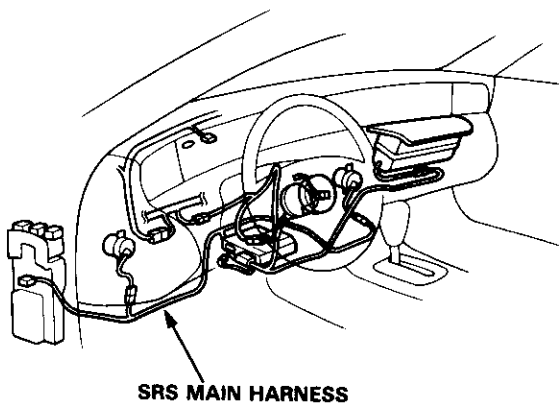

1. Remove the tweeter covers from the dashboard.

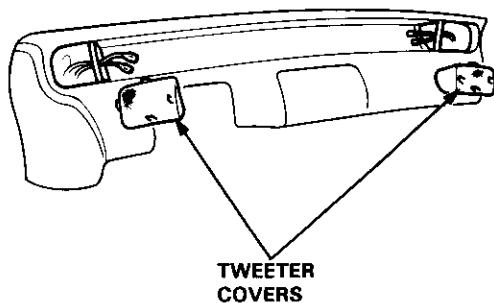

2. Remove the screws and the instrument panel visor.

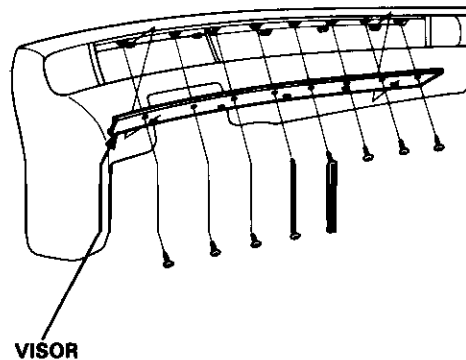

3. Remove the screws and the black face panel, then disconnect the 6-P connector from the clock reset switch.

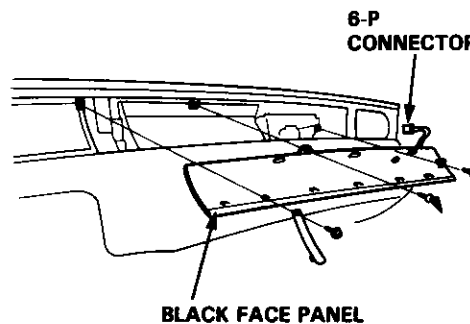



Main Gauge Assembly:

4. Remove the four screws from the main gauge assembly.

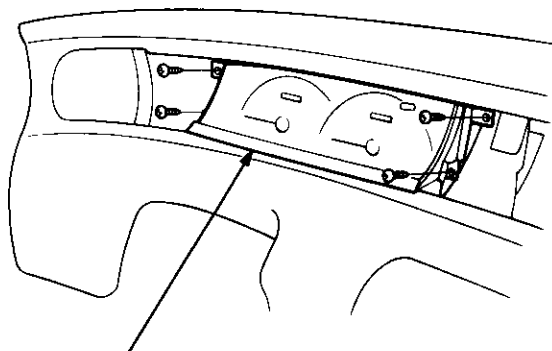

MAIN GAUGE ASSEMBLY

5. Place a cloth over the dashboard to protect the main gauge assembly, then pull the assembly out and disconnect its connectors.

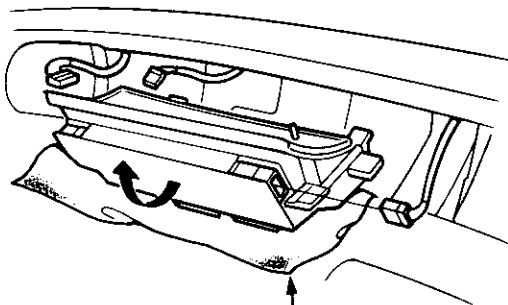

PROTECTIVE CLOTH

Sub Gauge Assembly:

6. Remove the four screws from the sub gauge assembly.

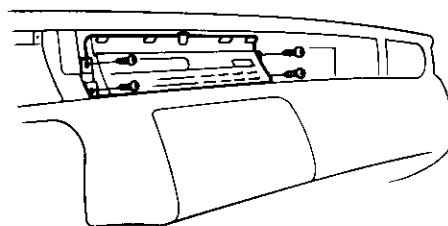

7. Place a cloth over the dashboard to protect the sub gauge assembly, then pull the assembly out and disconnect its connectors.

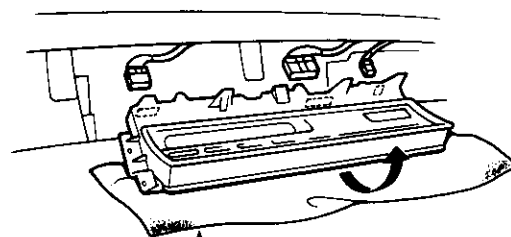

PROTECTIVE CLOTH

Gauge Assembly

Bulb Locations

Main Gauge Assembly:

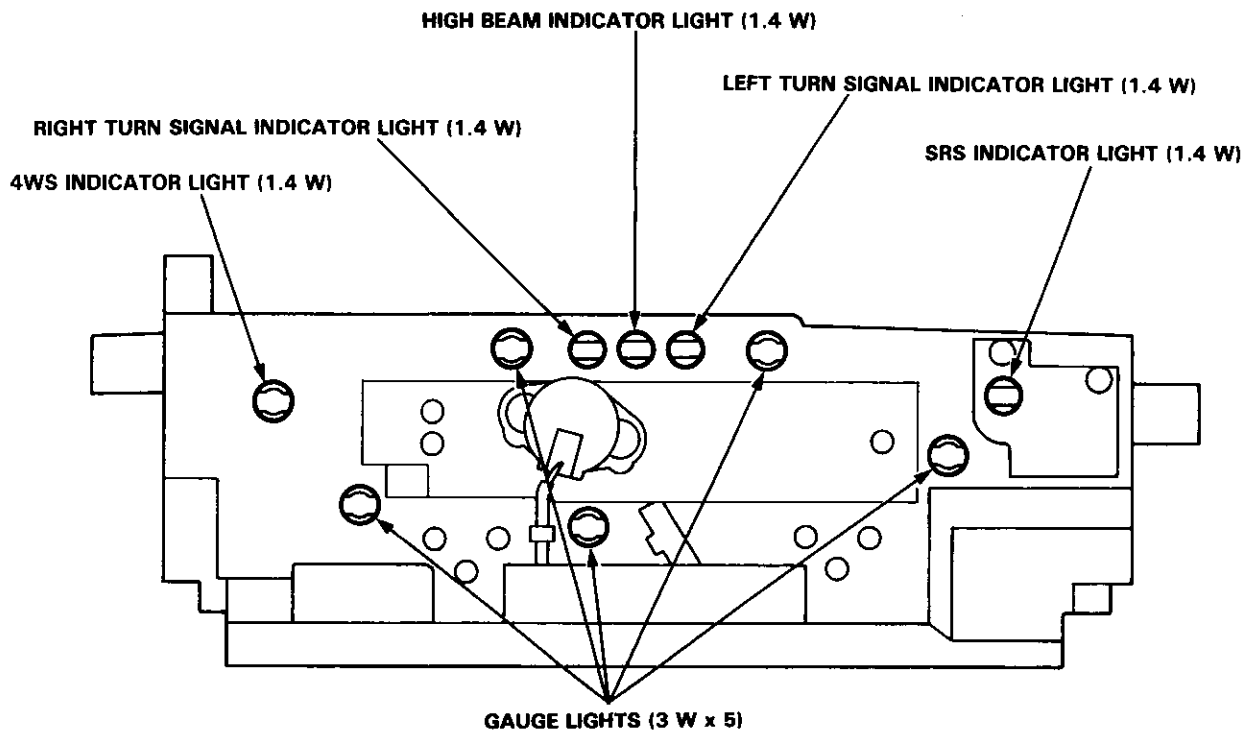



Sub Gauge Assembly:

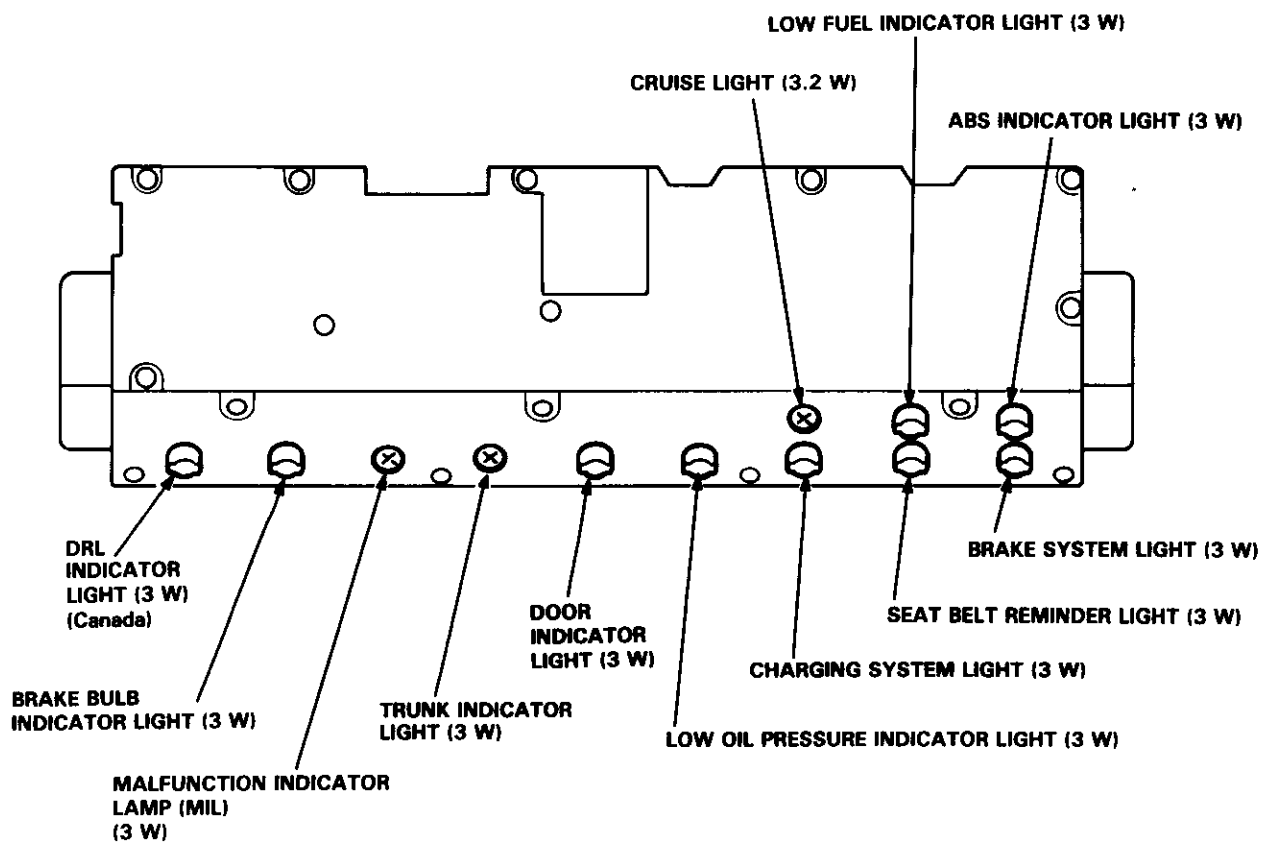

Gauge Assembly

Disassembly

Main Gauge Assembly:

NOTE:

- Handle the terminals and printed circuit boards carefully to avoid damaging them.
- If either the speedometer or the tachometer is faulty, replace them both as a unit.

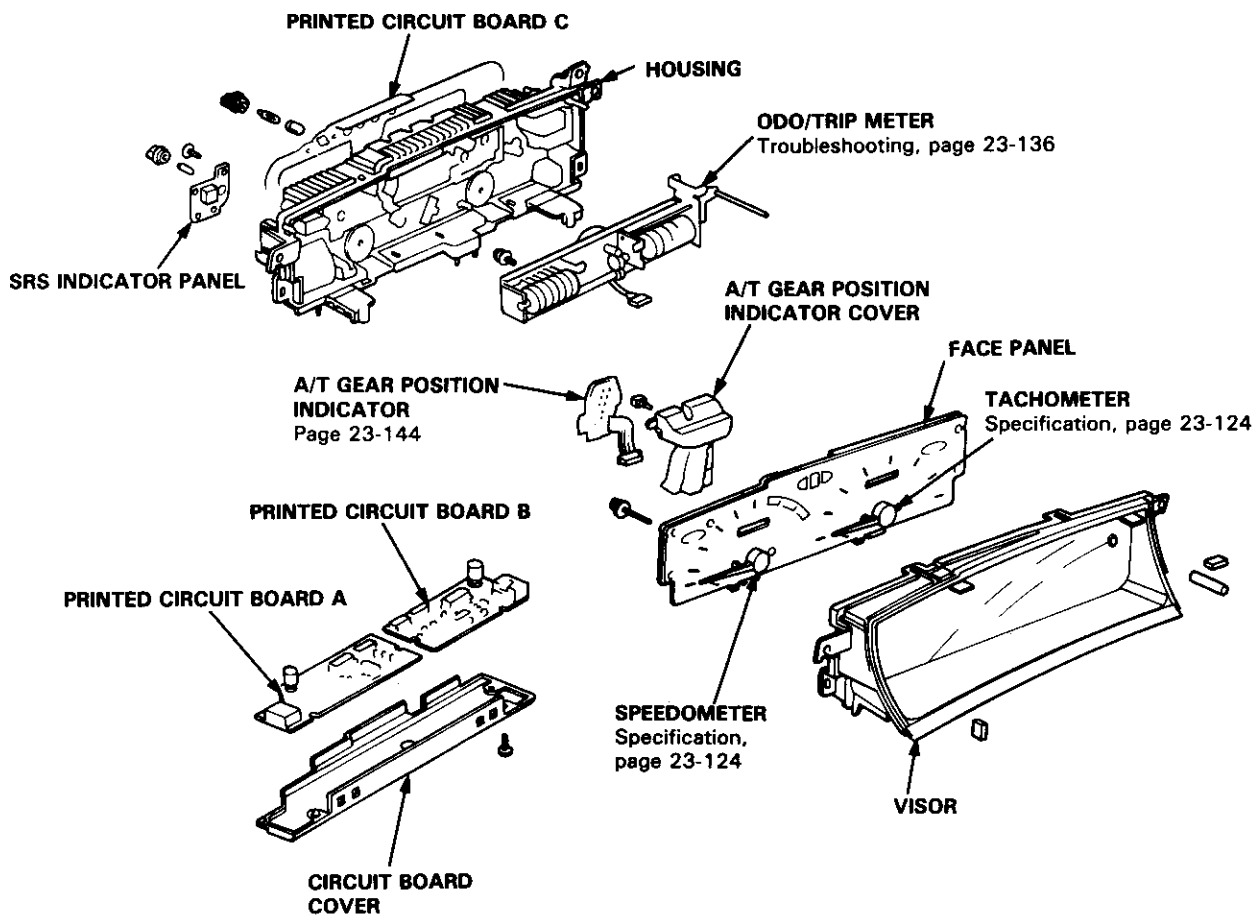
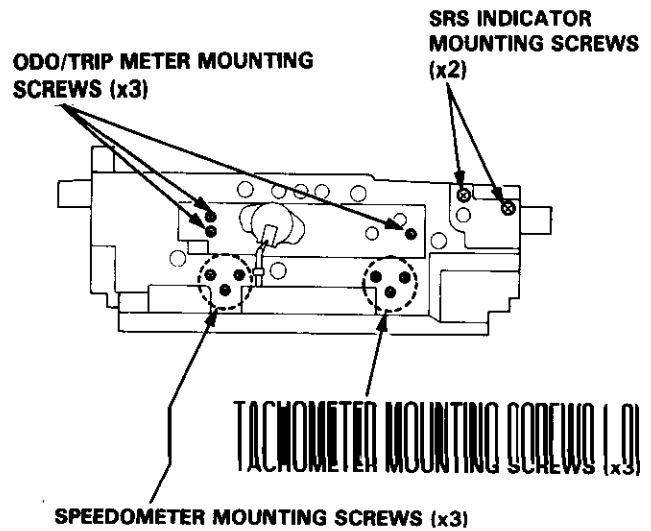



Sub Gauge Assembly:

NOTE: Handle the terminals and printed circuit boards carefully to avoid damaging them.

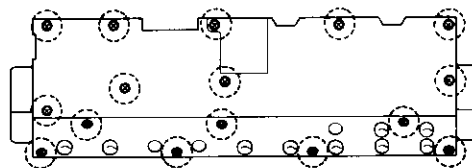

**PRINTED CIRCUIT BOARD/REAR COVER
MOUNTING SCREWS (x 16)**

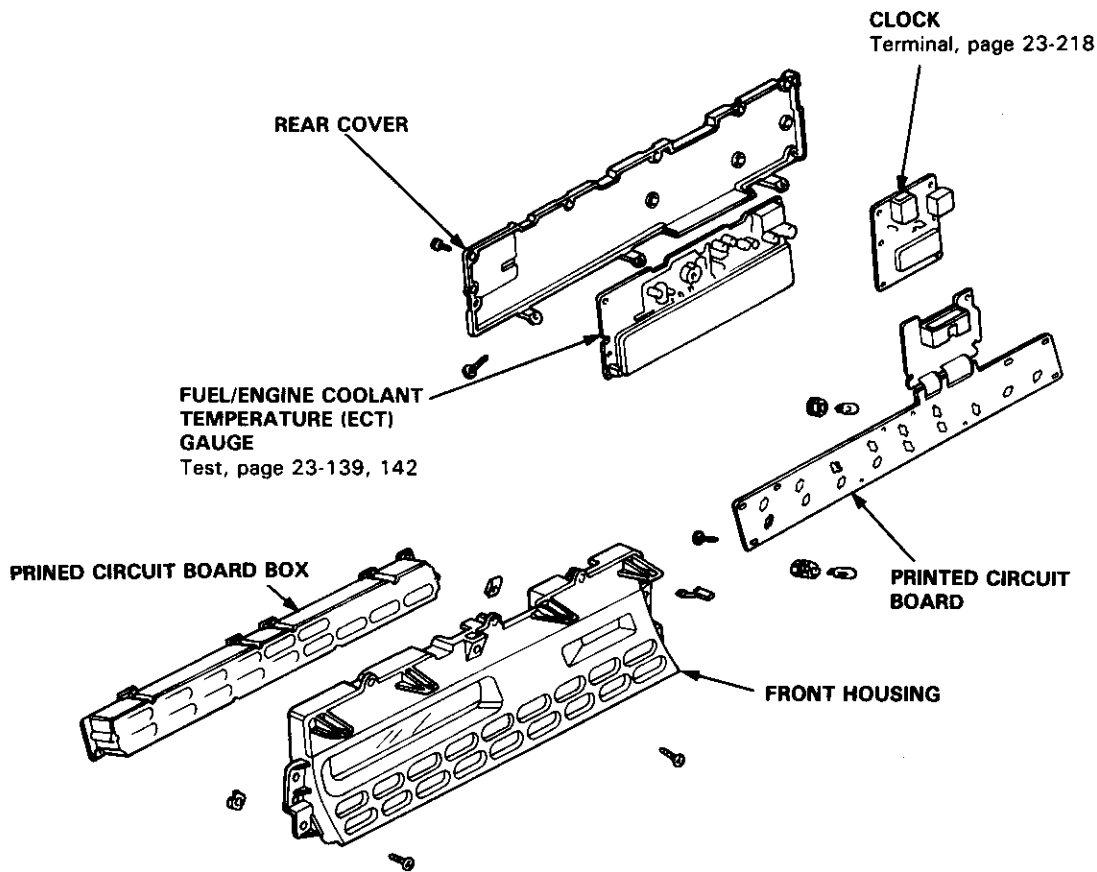

Speedometer/Trip Meter/Odometer

Troubleshooting

NOTE: The numbers in the table show the troubleshooting sequence.

Item to be inspected	Blown No. 23 (15 A) fuse (In the under-dash fuse/relay box)	Speedometer	Odo/Trip meter	Printed circuit board	Vehicle speed sensor (VSS) input test	Odometer connector at printed circuit board	VSS test flow chart
Symptom							
Odometer and trip meter work, but speedometer does not.		1		2			
Speedometer works, but odometer and trip meter do not.			1	2		3	
Speedometer, odometer, and trip meter do not work.	1				2		3

NOTE: VSS ground is via ECM (G101).

VSS Input Test (At harness side of 3-P connector)

No.	Wire	Test condition	Test: Desired result	Possible cause if result is not obtained
1	BLK	Under all conditions	Check for continuity to ground: There should be continuity.	<ul style="list-style-type: none"> An open in the wire. Poor ground (G101).
2	BLK/YEL	Ignition switch ON	Check for voltage to ground: There should be battery voltage.	<ul style="list-style-type: none"> Blown No. 23 (15 A) fuse Short to ground
3	ORN	Ignition switch ON	Check for voltage to ground: There should be about 5 V	<ul style="list-style-type: none"> Short to ground An open in the wire.

NOTE: A short to ground in the ORN wire can be caused by a short in any component connected to it.

VSS Test

Speedometer does not work.

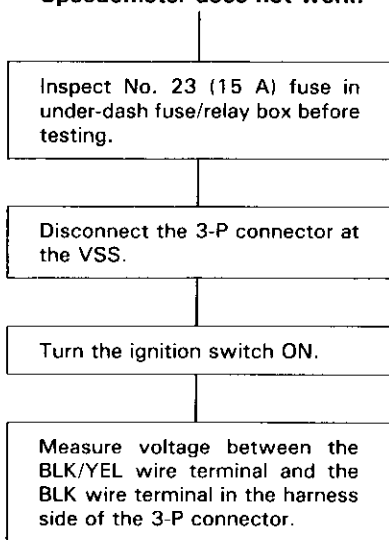

(To next page)

View from terminal side

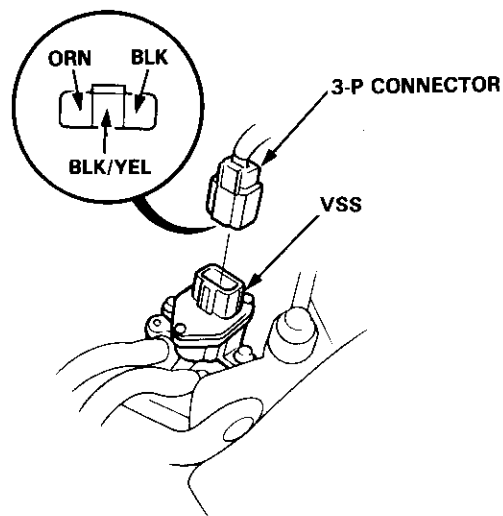

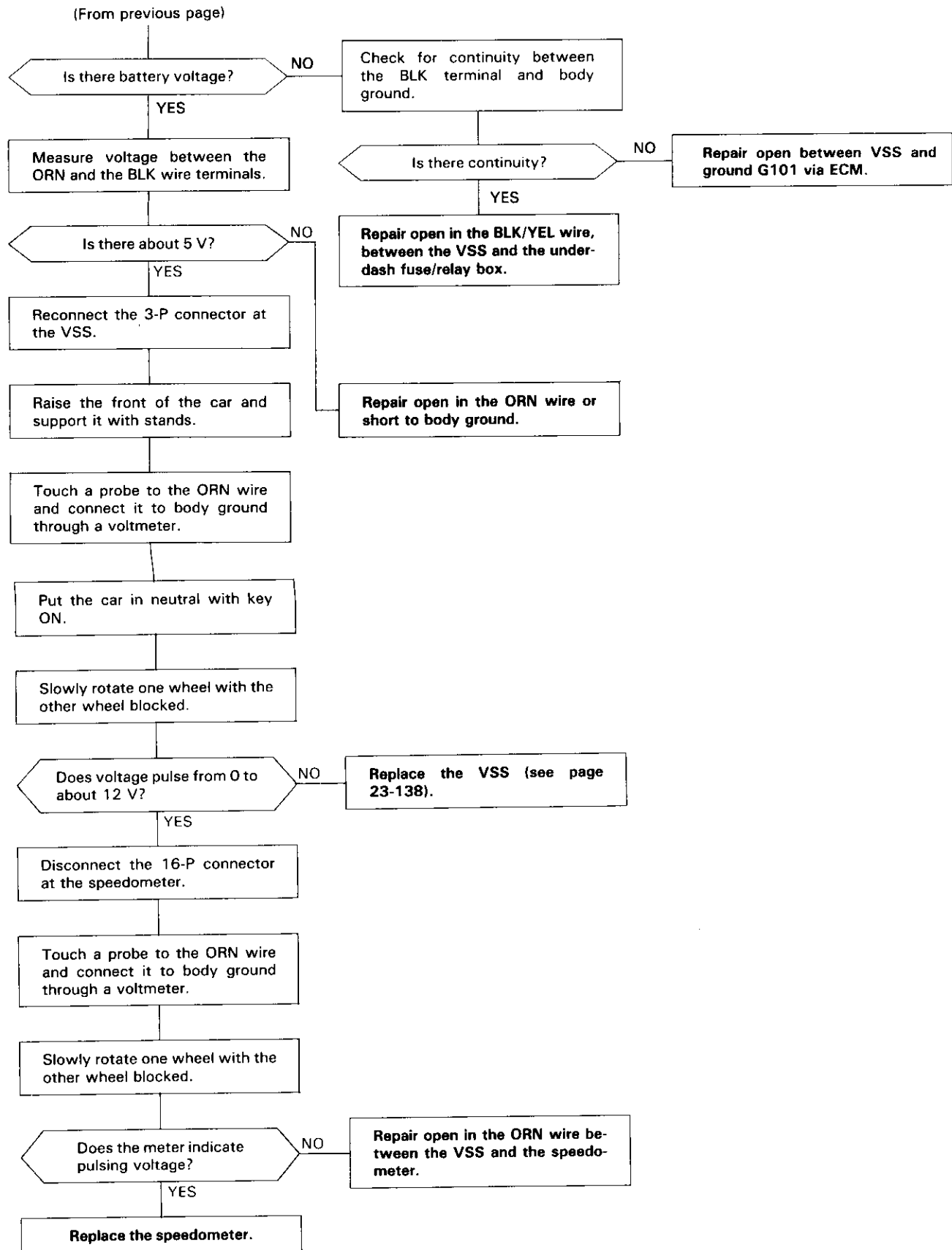

Vehicle Speed Sensor (VSS)

Replacement

1. Disconnect the 3-P connector from the vehicle speed sensor (VSS).
2. Remove the mounting bolts, then remove the VSS.

NOTE: The VSS drive link is a very small part, be careful not to lose it.

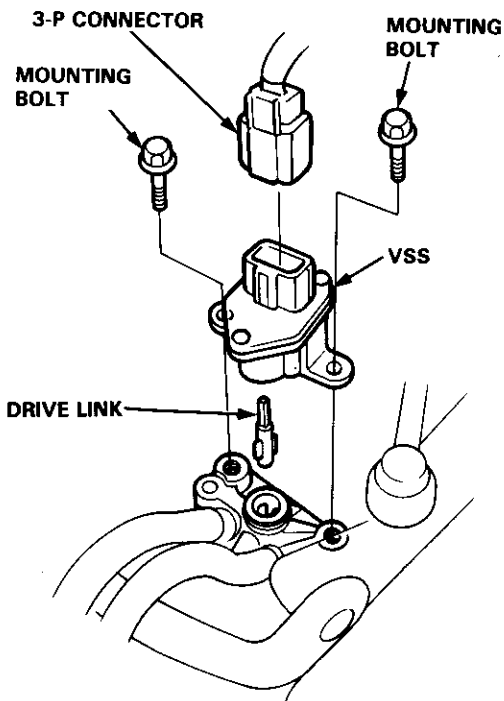

3. Install in the reverse order of removal.

Engine Low Oil Pressure Indicator System

Switch Test

1. Remove the YEL/RED wire from the engine oil pressure switch.
2. Check for continuity between the positive terminal and the engine (ground).
 - There should be continuity with the engine stopped.
 - There should be no continuity when the engine runs.

ENGINE OIL PRESSURE SWITCH
18 N·m (1.8 kg-m, 13.0 lb-ft)
1/8 in. BSP (British Standard Pipe Taper) 28 threads/inch.
Use proper liquid sealant.

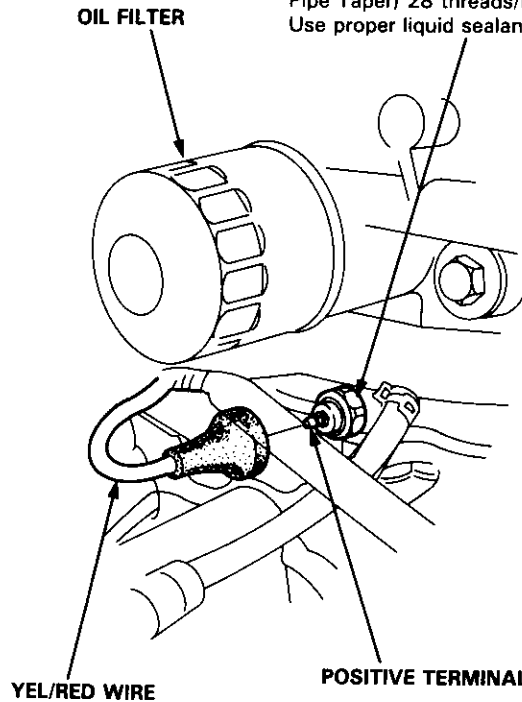

3. If the switch fails to operate, check the engine oil level. If the engine oil level is OK, check the engine oil pressure and, if necessary, inspect the oil pump (see section 8).

Fuel Gauge

Gauge Test



NOTE: Refer to page 23-129 for the circuit diagram of the fuel gauge.

1. Check the No. 13 (10 A) fuse in the under-dash fuse/relay box before testing.
2. Open the trunk.
3. Remove the fuel tank access panel.
4. Disconnect the 5-P connector from the fuel gauge sending unit.

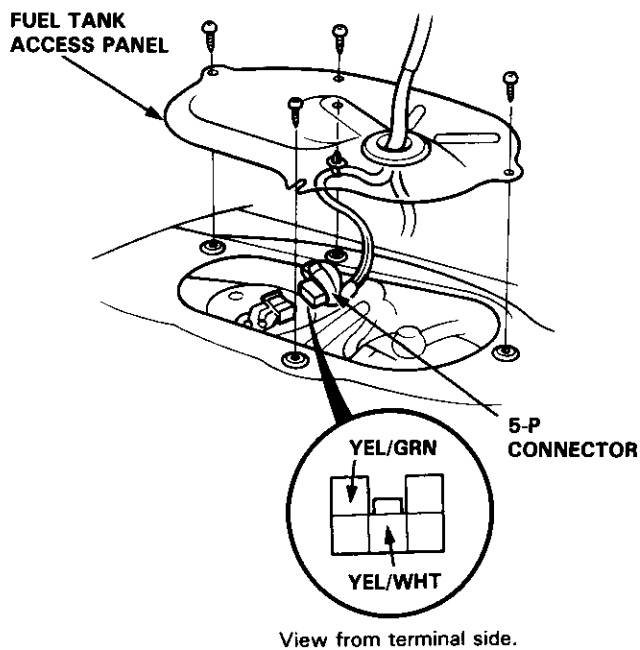

5. Connect the voltmeter positive probe to the YEL/GRN terminal and the negative probe to body ground, then turn the ignition switch ON. There should be between 5 and 8 V.

- If the voltage is as specified, go to step 5.
- If the voltage is not as specified, check for:
 - An open in the YEL or YEL/GRN wire.
 - Loose or disconnected terminals.
 - Faulty fuel gauge.

6. Turn the ignition switch OFF. Connect a jumper wire between the YEL/GRN and YEL/WHT terminals.

CAUTION: Do not connect power and ground to the terminals; it will damage the fuel gauge.

7. Turn the ignition switch ON, and check if the gauge indicates "F"

CAUTION: Disconnect the jumper wire as soon as the gauge reaches "F", or you will damage the gauge.

- If the fuel gauge does not work at all, replace it.
- If the fuel gauge is OK, inspect the sending unit.

Fuel Gauge

Sending Unit Test

⚠ WARNING Do not smoke while working on the fuel system. Keep open flame away from the work area.

1. Open the trunk.
2. Remove the fuel tank access panel.
3. With the ignition switch OFF, disconnect the 5-P connector from the fuel gauge sending unit.
4. Remove the five nuts, then take the sending unit assembly out of the fuel tank.

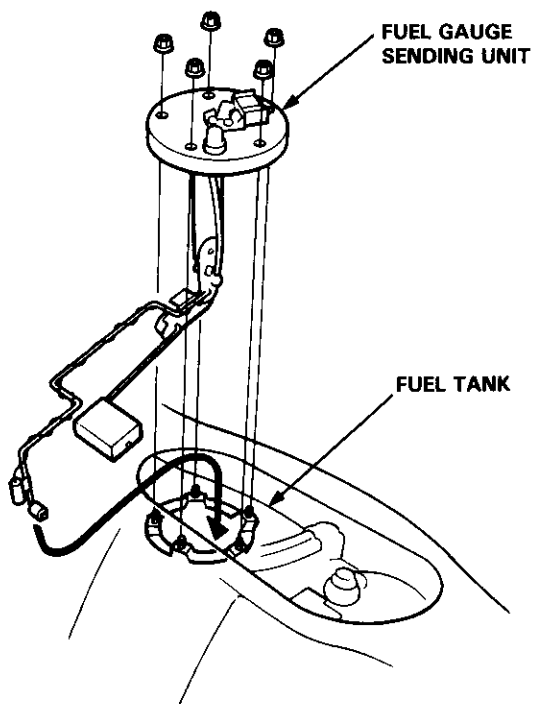

5. Measure the resistance between the A and B terminals.
 - If it is more than about 270–330 Ω , replace the fuel sending unit.
 - If it is within about 270–330 Ω , go to step 6.

6. Check the resistance between the B and C terminals. It should change evenly as you change the position of the float.
 - If it does not change evenly, replace the fuel sending unit.
 - If it changes evenly, go to step 7.
7. Support the sending unit on a workbench in the position shown.

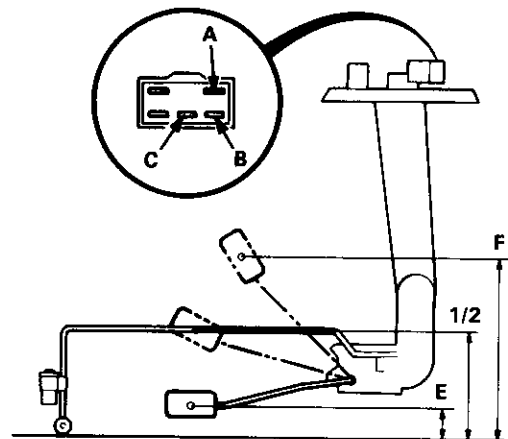

Top of the workbench (Bottom of the fuel tank)

8. Measure the resistance between the B and C terminals by moving the float to the distances listed for E (EMPTY), 1/2 (HALF FULL), and F (FULL).

Float Position	E	1/2	F
Resistance (Ω)	16–32	116–188	239–314

E	1/2	F
20.5 mm (0.80 in)	73.6 mm (2.90 in)	126 mm (4.7 in)

9. If unable to obtain the above readings, replace the fuel gauge sending unit.

Low Fuel Indicator System



Indicator Light Test

NOTE: Refer to page 23-127 for the diagram of the low fuel indicator circuit.

1. Park the car on level ground.

⚠ WARNING Do not smoke while working on the fuel system. Keep open flame away from the work area. Drain fuel only into an approved container.

2. Drain the fuel tank into an approved container. Then install the drain bolt with a new washer.
3. Add less than 9.0 ℓ (2.4 U.S. Gal, 2.0 Imp. Gal) of fuel and turn the ignition switch ON. The low fuel indicator light should come on within four minutes.

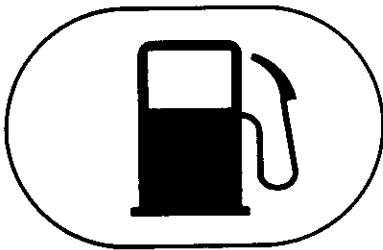

LOW FUEL INDICATOR LIGHT
(In the sub gauge assembly)

- If the light goes on within four minutes, go on to step 5.
- If the light does not go on within four minutes, go on to step 4.

4. Remove the fuel tank access panel and disconnect the 5-P connector from the fuel gauge sending unit. Connect the GRN/WHT terminal to the BLK terminal with a jumper wire.

- If the light comes on, the problem is the sending unit.
- If the light does not come on, the problem is an open in the GRN/WHT wire to the gauge assembly, no power to the gauge, a bad bulb, or poor ground.

FUEL TANK ACCESS
PANEL

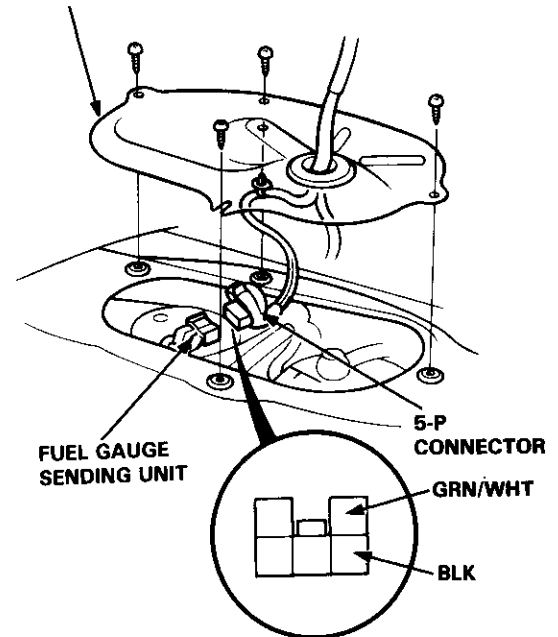

View from terminal side.

5. Add one more gallon of fuel [approx. 4 ℓ (1.1 U.S. Gal, 0.9 Imp. Gal)]. The light should go off within four minutes.

Engine Coolant Temperature (ECT) Gauge

Gauge Test

NOTE: Refer to page 23-129 for the circuit diagram of the engine coolant temperature (ECT) gauge.

1. Check the No. 13 (10 A) fuse in the under-dash fuse/relay box before testing.
2. Make sure the ignition switch is OFF, then disconnect the RED wire from the ECT sending unit and ground it with a jumper wire.

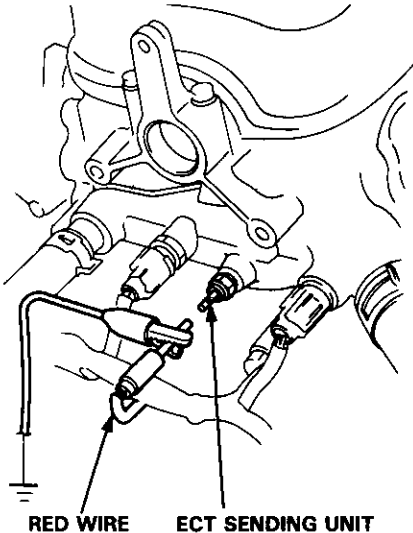

3. Turn the ignition switch ON. Check that the segments of the ECT gauge light up.

CAUTION: Turn the ignition switch OFF immediately after the segments light up. Failure to do so may damage the gauge.

- If the segments do not light up, check for an open in the YEL or RED wire. If the wire is OK, replace the ECT gauge.
- If the segments light up, check the sending unit.

Sending Unit Test

1. Disconnect the RED wire from the sending unit.
2. With the engine cold, use an ohmmeter to measure resistance between the positive terminal and the engine (ground).

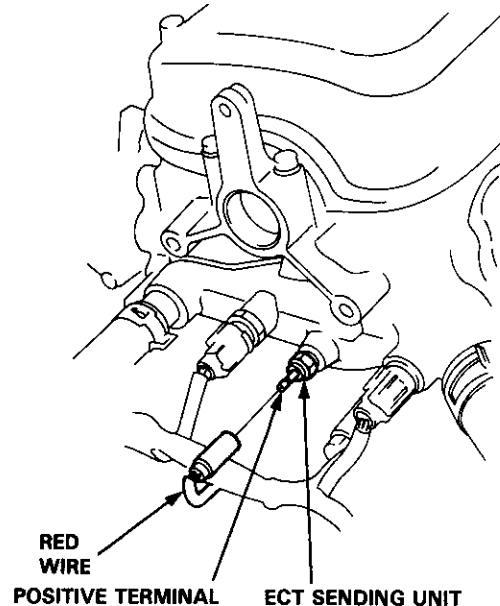

3. Check the temperature of the coolant.
4. Run the engine and measure the change in resistance with the engine at operating temperature (radiator fan comes on).

Coolant Temperature	133°F (56°C) (Engine cold)	185°F (85°C)– 212°F (100°C)
Resistance (Ω)	142	49–32

5. If the readings you get are substantially different from the specifications above, replace the ECT sending unit.



Brake System Light

Parking Brake Switch Test

1. Remove the floor console and disconnect the connector from the switch.
2. Check continuity between the positive terminal and body ground.
 - There should be continuity with the brake lever up.
 - There should be no continuity with the brake lever down.

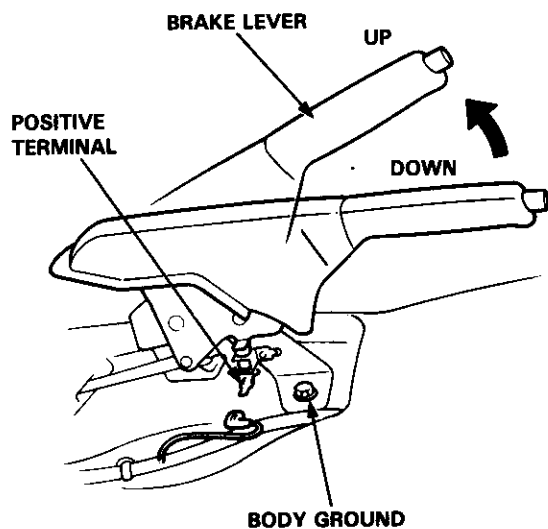

Canada:

NOTE: If the parking brake switch is OK, but the brake system light does not work, perform the input test for the daytime running lights control unit (see page 23-180).

Brake Fluid Level Switch Test

1. Remove the reservoir cap. Check that the float moves up and down freely; if it doesn't, replace the reservoir cap assembly.
2. Check for continuity between the terminals with the float up and down.
 - There should be continuity with the float down.
 - There should be no continuity with the float up. Replace the reservoir cap assembly if necessary.

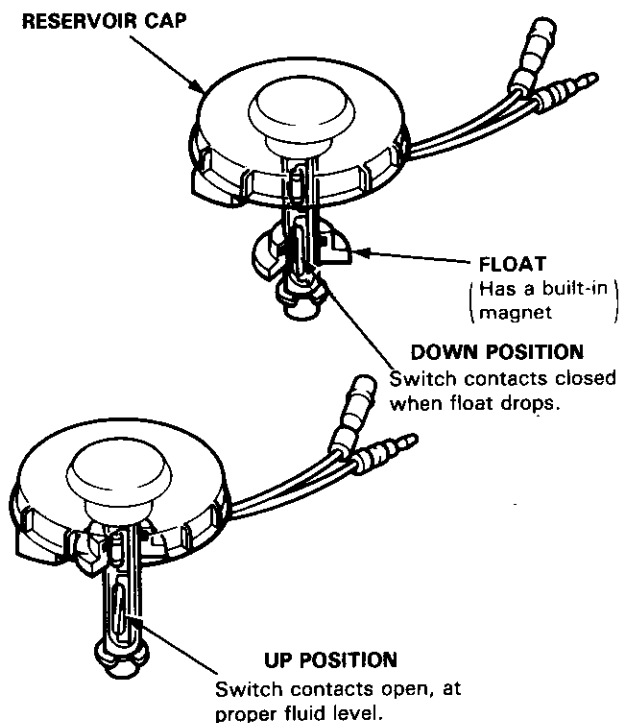

A/T Gear Position Indicator

Component Location Index

CAUTION:

- All SRS electrical wiring harnesses are covered with yellow outer insulation.
- Before disconnecting the SRS wire harness, install the short connector(s) on the airbag(s) (see page 23-294).
- Replace the entire affected SRS harness assembly if it has an open circuit or damaged wiring.
- After installing the gauge assembly, recheck the operation of the SRS indicator light.

MAIN GAUGE ASSEMBLY

Removal, page 23-130

Disassembly, page 23-134

INTERLOCK SYSTEM

See page 23-158

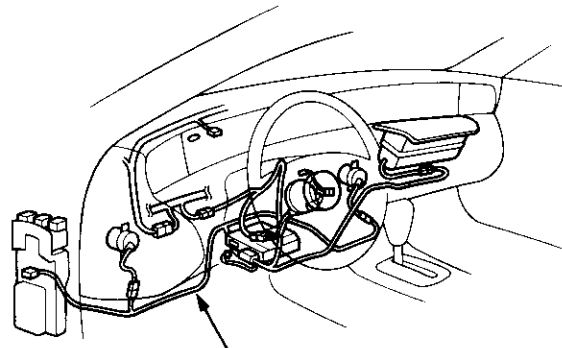

SRS MAIN HARNESS

A/T GEAR POSITION INDICATOR

Input Test, page 23-146

Bulb Replacement, page 23-150

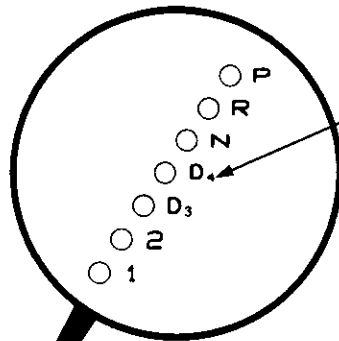

TRANSMISSION CONTROL MODULE (TCM)

See Automatic Transmission, section 14

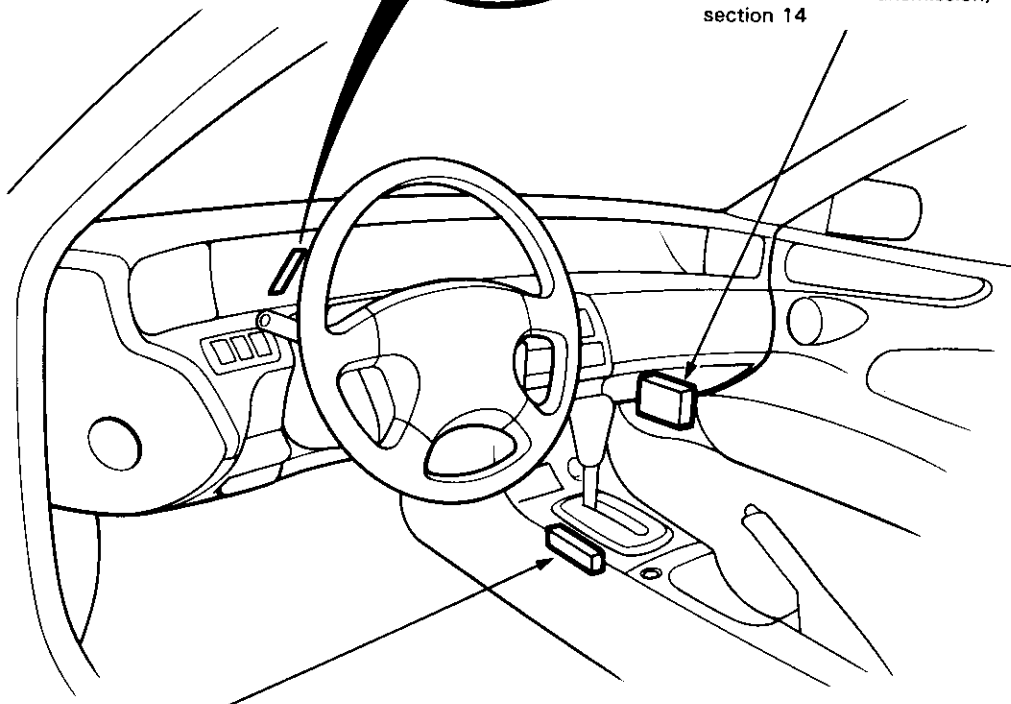

A/T GEAR POSITION SWITCH

Test, page 23-148

Replacement, page 23-149



Circuit Diagram

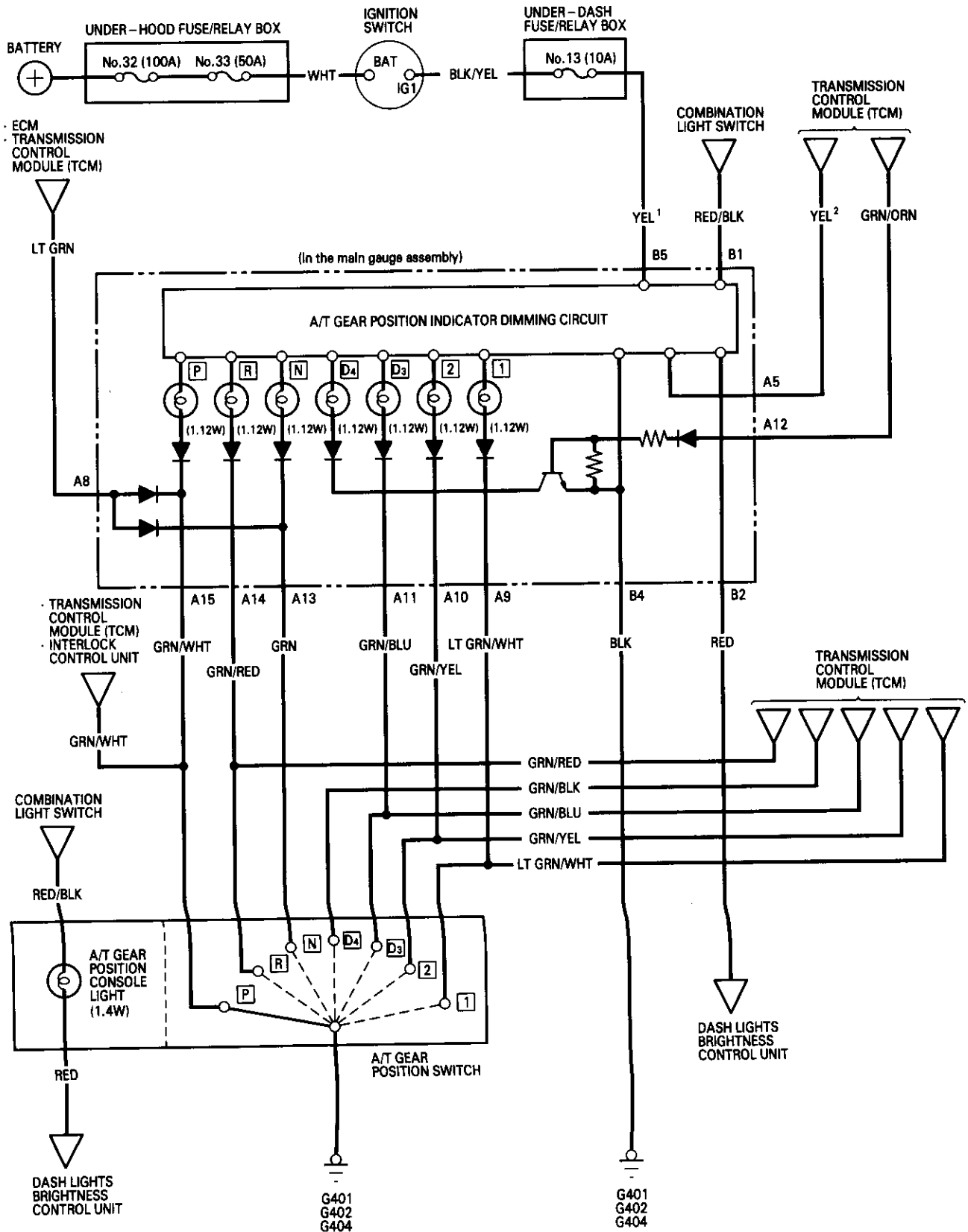

A/T Gear Position Indicator

Indicator Input Test

CAUTION:

- All SRS electrical wiring harnesses are covered with yellow outer insulation.
- Before disconnecting the SRS wire harness, install the short connector(s) on the airbag(s) (see page 23-294).
- Replace the entire affected SRS harness assembly if it has an open circuit or damaged wiring.
- After installing the gauge assembly, recheck the operation of the SRS indicator light.

1. Remove the main gauge assembly from the dashboard (see page 23-130).
2. Disconnect the 16-P and 10-P connectors from it.
3. Inspect the connector and socket terminals to be sure they are all making good contact.

- If the terminals are bent, loose, or corroded, repair them as necessary, and recheck the system.
- If the terminals look OK, make the following input tests at the connector.
 - If a test indicates a problem, find and correct the cause, then recheck the system.
 - If all the input tests prove OK, the indicator must be faulty; replace the gauge assembly.

NOTE: Different wires with the same color have been given a number suffix to distinguish them (YEL¹ and YEL² are not the same).

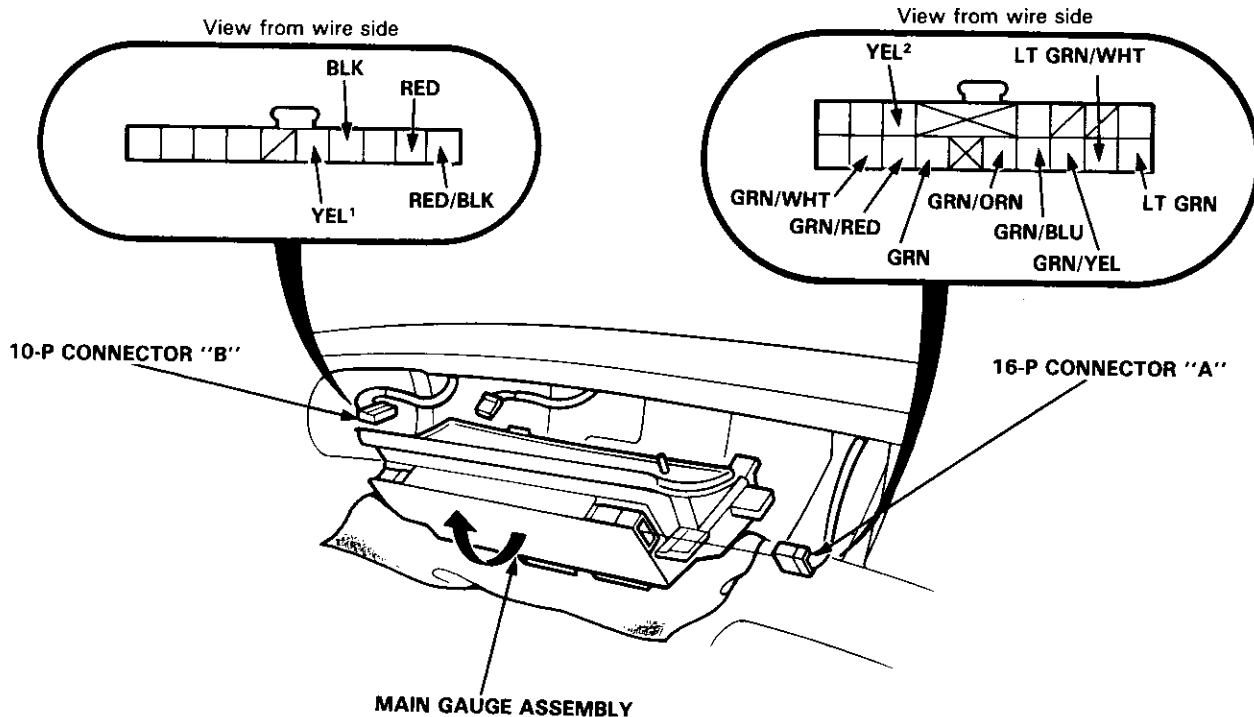
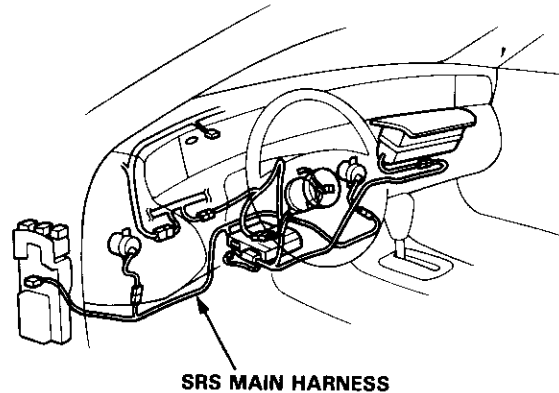



No.	Wire	Test condition	Test: Desired result	Possible cause if result is not obtained
1	BLK	Under all conditions.	Check for continuity to ground: There should be continuity.	<ul style="list-style-type: none"> • Poor ground (G401, G402, G404). • An open in the wire.
2	YEL ¹	Ignition switch ON.	Check for voltage to ground: There should be battery voltage.	<ul style="list-style-type: none"> • Blown No. 1 (10 A) fuse. (In the under-dash fuse/relay box) • An open in the wire.
3	GRN/WHT	Shift lever in P . NOTE: Don't push the brake pedal.	Check for continuity to ground: There should be continuity. NOTE: There should be no continuity in any other position.	<ul style="list-style-type: none"> • Faulty A/T gear position switch. • Poor ground (G401, G402, G404). • An open in the wire.
	GRN/RED	Shift lever in R .		
	GRN	Shift lever in N .		
	GRN/BLU	Shift lever in D₃ .		
	GRN/YEL	Shift lever in 2 .		
	LT GRN/WHT	Shift lever in 1 .		
4	RED and RED/BLK	Combination light switch ON and dash lights brightness control dial on full bright.	Check for voltage between RED/BLK and RED terminals: There should be battery voltage.	<ul style="list-style-type: none"> • Faulty dash lights brightness control system. • An open in the wire.
5	GRN/ORN	Ignition switch ON and shift lever in any position except D₄ .	Check for voltage to ground: There should be battery voltage for two seconds after the ignition switch is turned ON, and less than 1 V two seconds later.	<ul style="list-style-type: none"> • Faulty transmission control module (TCM). • An open in the wire.
6	YEL ²	Ignition switch ON and shift lever in any position except D₄ .	Check for voltage to ground: There should be less than 1 V for two seconds after the ignition switch is turned ON, and more than 5 V two seconds later.	<ul style="list-style-type: none"> • Faulty TCM. • An open in the wire.
7	LT GRN	Ignition switch ON.	Check for voltage to ground: There should be more than 11 V.	<ul style="list-style-type: none"> • Faulty ECM or TCM. • An open in the wire.

A/T Gear Position Indicator

A/T Gear Position Switch Test

CAUTION:

- All SRS electrical wiring harnesses are covered with yellow outer insulation.
- Before disconnecting the SRS wire harness, install the short connector(s) on the airbag(s) (see page 23-294).
- Replace the entire affected SRS harness assembly if it has an open circuit or damaged wiring.
- After installing the gauge assembly, recheck the operation of the SRS indicator light.

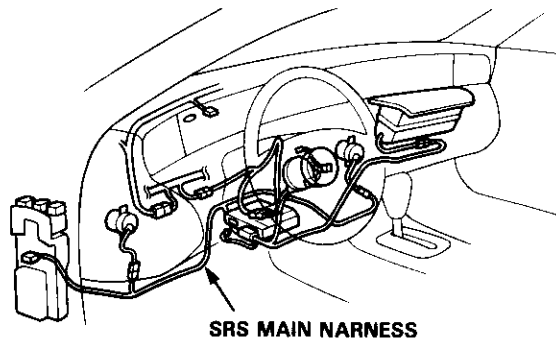

SRS MAIN HARNESS

1. Remove the console, then disconnect the 12-P and 3-P connectors from the switch.
2. Check for continuity between the terminals in each switch position according to the table.
 - Move the lever back and forth at each position without touching the push button, and check for continuity within the range of free play.
 - If there is no continuity within the range of free play, adjust the position of the switch as described on the next page.

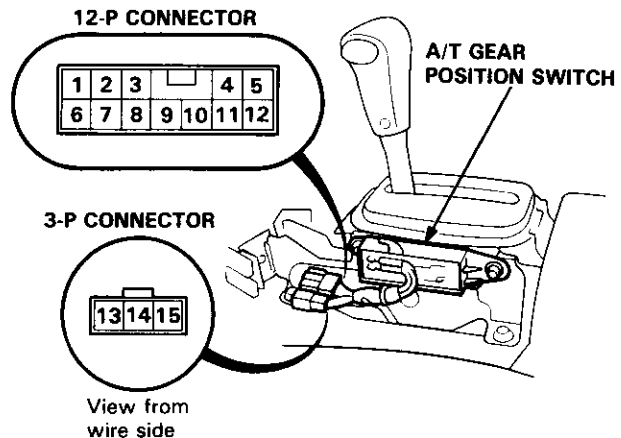

Terminal Position	A/T Gear Position Switch										Back - up Light Switch		Neutral Position Switch	
	8	1	2	3	4	5	6	7	11	9	10	13	15	
1	○				○									
2	○			○		○								
D3	○		○			○								
D4	○	○				○								
N	○						○					○	○	
R	○							○		○	○			
P	○								○			○	○	



A/T Gear Position Switch Adjustment

1. Shift to the **P** position and loosen the switch nuts.
2. Slide the switch rearward [up to 2.0 mm (0.08 in)] until there is continuity between No. 8 and No. 11 terminals within the range of free play of the shift lever.
3. Recheck for continuity between each of the terminals.

NOTE:

- If adjustment is not possible, check for damage to the shift lever detent and/or bracket. If there is no damage, replace the A/T gear position switch.
- The engine should start when the shift lever is in position **P** anywhere within the range of free play.

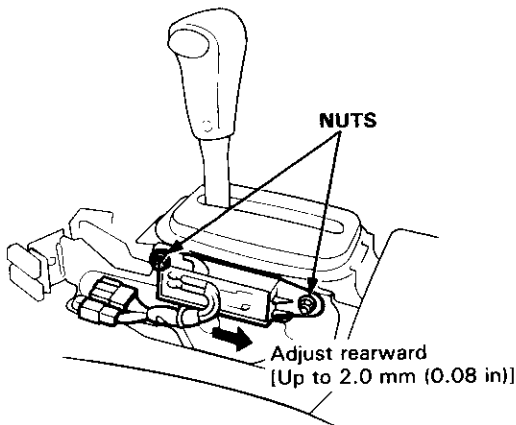
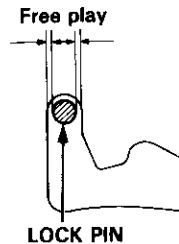

A/T Gear Position Switch Replacement

1. Remove the console, then disconnect the 12-P and 3-P connectors from the switch.
2. Remove the two mounting nuts and remove the switch.

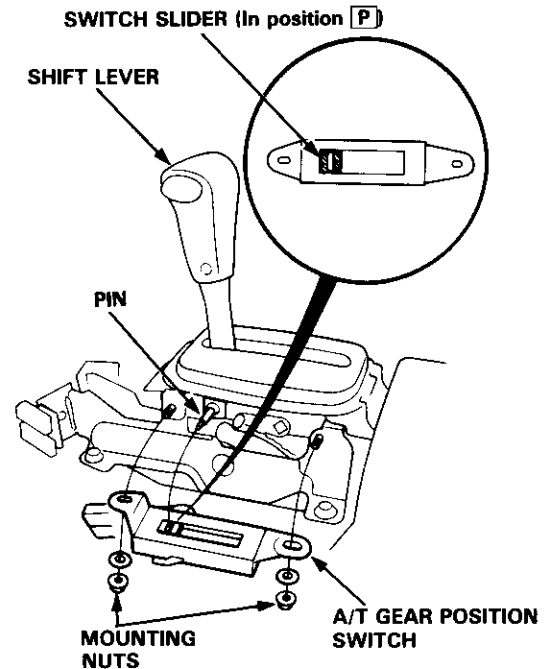

3. Position the slider on the new switch to position **P** as shown above.
4. Shift the lever to "Neutral", then slip the switch into position.
5. Attach the switch with the two mounting nuts.
6. Test the switch in the **P** and **N** positions.

NOTE: The engine should start when the shift lever is in position **P** anywhere in the range of free play.

7. Connect the 12-P and 3-P connectors, clamp the harness, and install the console.

A/T Gear Position Indicator

Bulb Replacement

CAUTION:

- All SRS electrical wiring harnesses are covered with yellow outer insulation.
- Before disconnecting the SRS wire harness, install the short connector(s) on the airbag(s) (see page 23-294).
- Replace the entire affected SRS harness assembly if it has an open circuit or damaged wiring.
- After installing the gauge assembly, recheck the operation of the SRS indicator light.

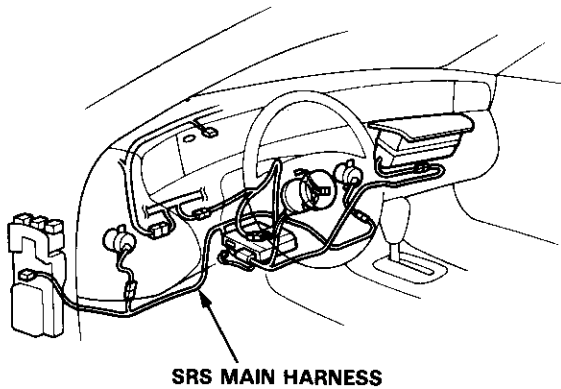

1. Remove the main gauge assembly (see page 23-130).
2. Disassemble the main gauge assembly (see page 23-134).
3. Remove the bulb from the A/T gear position indicator circuit board.

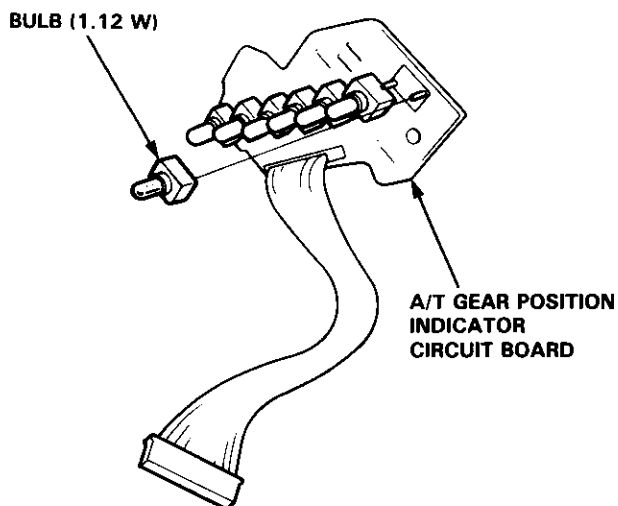

4. Install the indicator in the reverse order of removal.



Safety Indicator

Component Location Index

CAUTION:

- All SRS electrical wiring harnesses are covered with yellow outer insulation.
- Before disconnecting the SRS wire harness, install the short connector(s) on the airbag(s) (see page 23-294).
- Replace the entire affected SRS harness assembly if it has an open circuit or damaged wiring.
- After installing the gauge assembly, recheck the operation of the SRS indicator light.

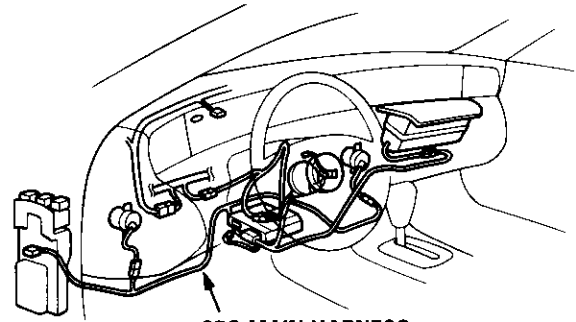

SRS MAIN HARNESS

SAFETY INDICATOR (In the sub gauge assembly)
 Troubleshooting, page 23-156
 Removal, page 23-130
 Input Test, page 23-154
 Bulb Replacement, page 23-133

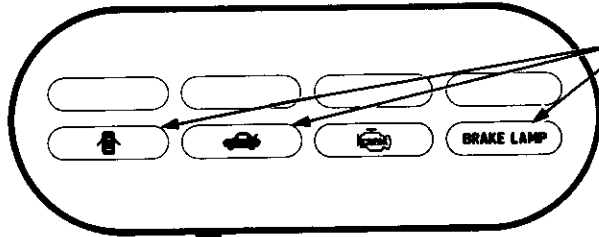

CEILING LIGHT
 Test/Replacement, page 23-190

HIGH MOUNT BRAKE LIGHT
 Replacement, page 23-195

PASSENGER'S DOOR SWITCH
 Test, page 23-191

BRAKE SWITCH
 Test, page 23-195

TRUNK LIGHT
 Test, page 23-189

RIGHT BRAKE LIGHT FAILURE SENSOR
 Test, page 23-157

DRIVER'S DOOR SWITCH
 Test, page 23-191

LEFT BRAKE LIGHT FAILURE SENSOR
 Test, page 23-157

TRUNK LATCH SWITCH
 Test/Replacement, page 23-189

Safety Indicator System:

Bulbs are used to indicate when the trunk lid or a door is not fully closed, or when a brake light is faulty. The bulbs will remain ON for about two seconds after the ignition switch has been turned ON to show that the system circuit is functioning.

Brake Light Bulb Failure Indicator:

If all brake light bulbs are OK, the indicator light stays off because the WHT/GRN wire is constantly being grounded by the two brake light failure sensors connected in series. With the brake light off, the ground is provided through the diode, the failure sensor relay coil, and the bulb filaments. With the brake light on, all four relays (three in the left sensor, one in the right sensor), connected in series, supply ground. If either of the two bulbs is not working, the chain is broken and the WHT/GRN wire is not being grounded. The indicator light comes on.

Safety Indicator

Circuit Diagram

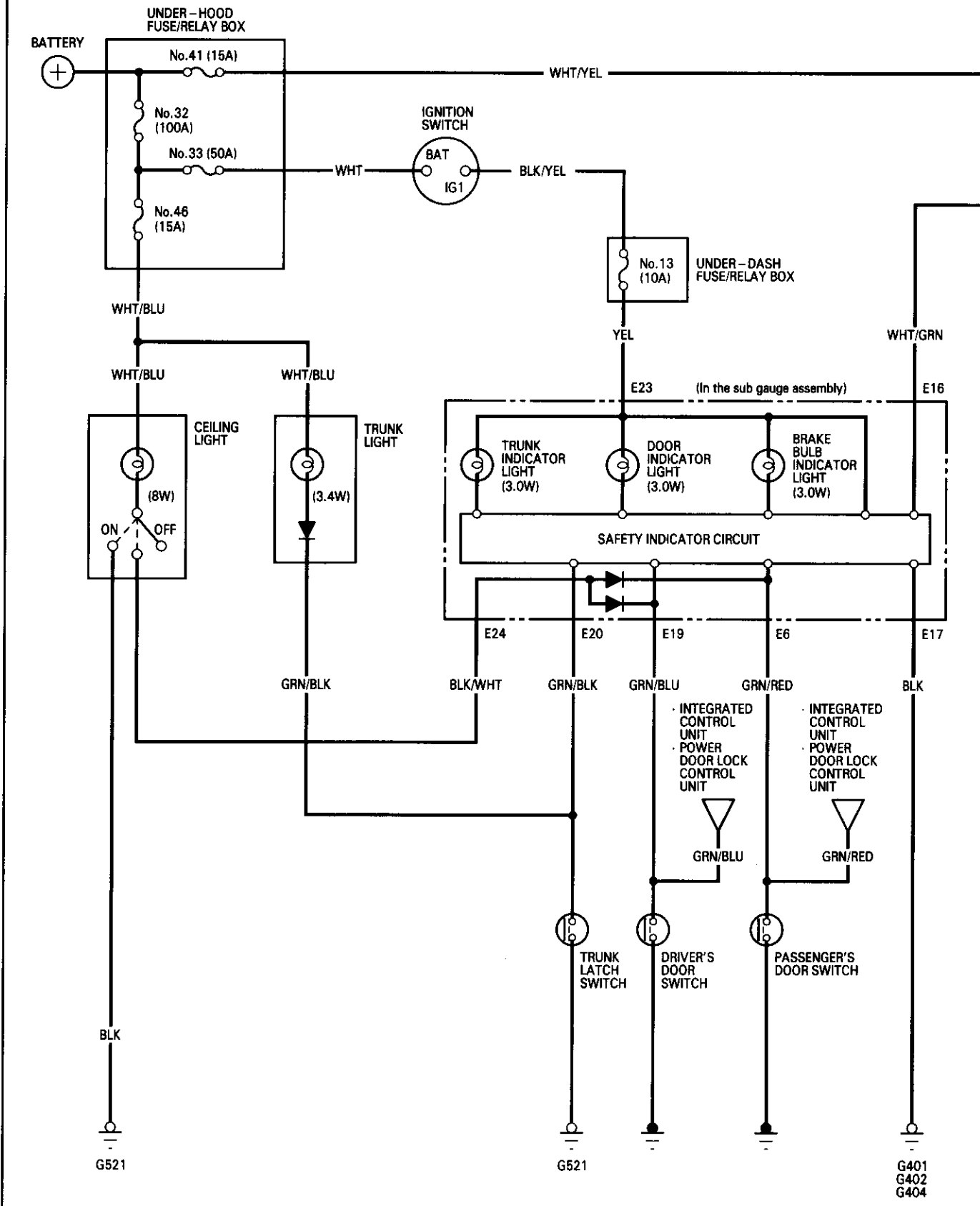

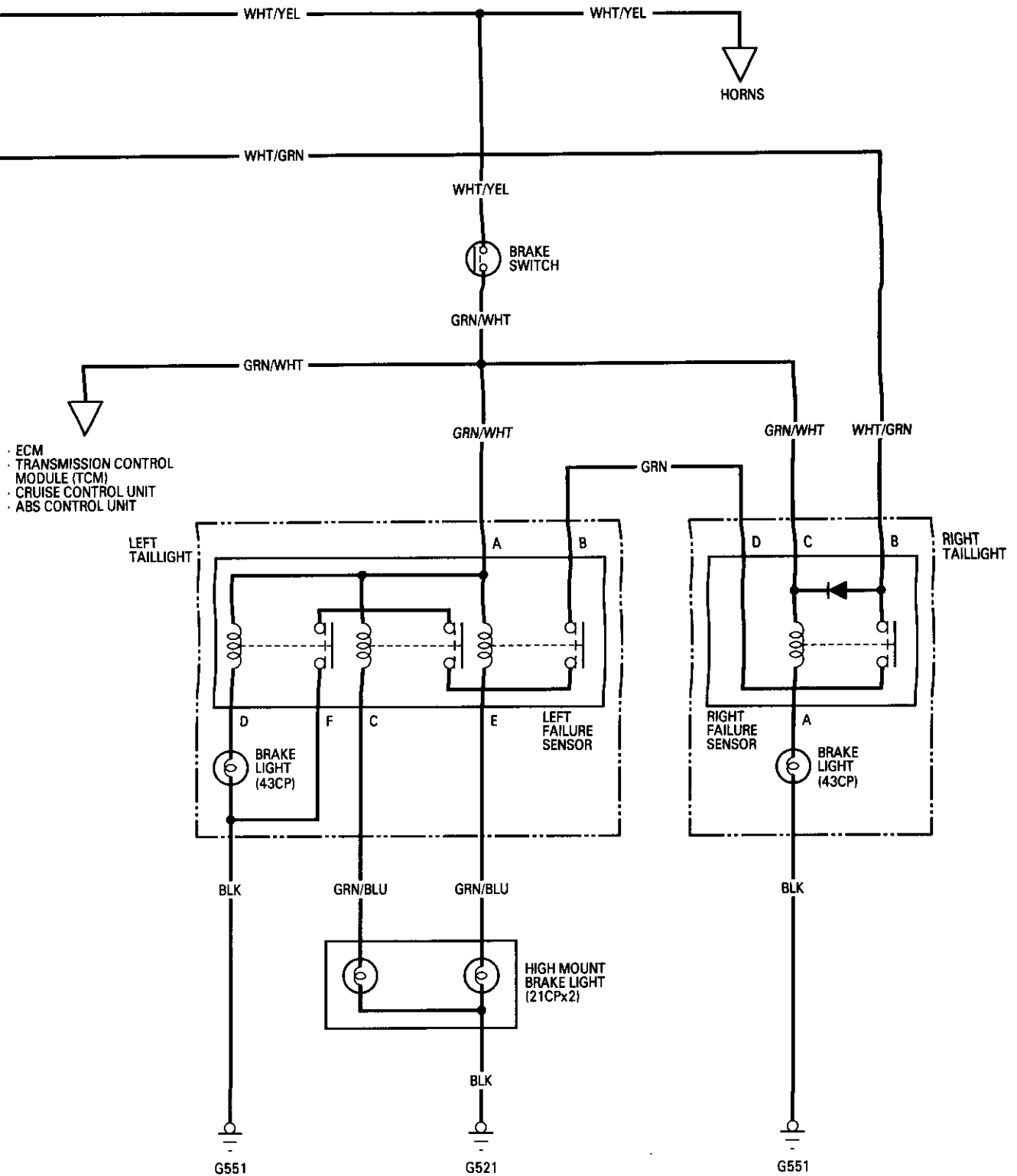

Safety Indicator

Indicator Input Test

CAUTION:

- All SRS electrical wiring harnesses are covered with yellow outer insulation.
 - Before disconnecting the SRS wire harness, install the short connector(s) on the airbag(s) (see page 23-294).
 - Replace the entire affected SRS harness assembly if it has an open circuit or damaged wiring.
 - After installing the gauge assembly, recheck the operation of the SRS indicator light.
1. Remove the sub gauge assembly from the dashboard (see page 23-130).
 2. Disconnect the 30-P connector from the sub gauge assembly.
 3. Inspect the connector and socket terminals to be sure they are all making good contact.
 - If the terminals are bent, loose, or corroded, repair them as necessary, and recheck the system.
 - If the terminals look OK, make the following input tests at the connector.
 - If a test indicates a problem, find and correct the cause, then recheck the system.
 - If all the input tests prove OK, the printed circuit board must be faulty; replace it.

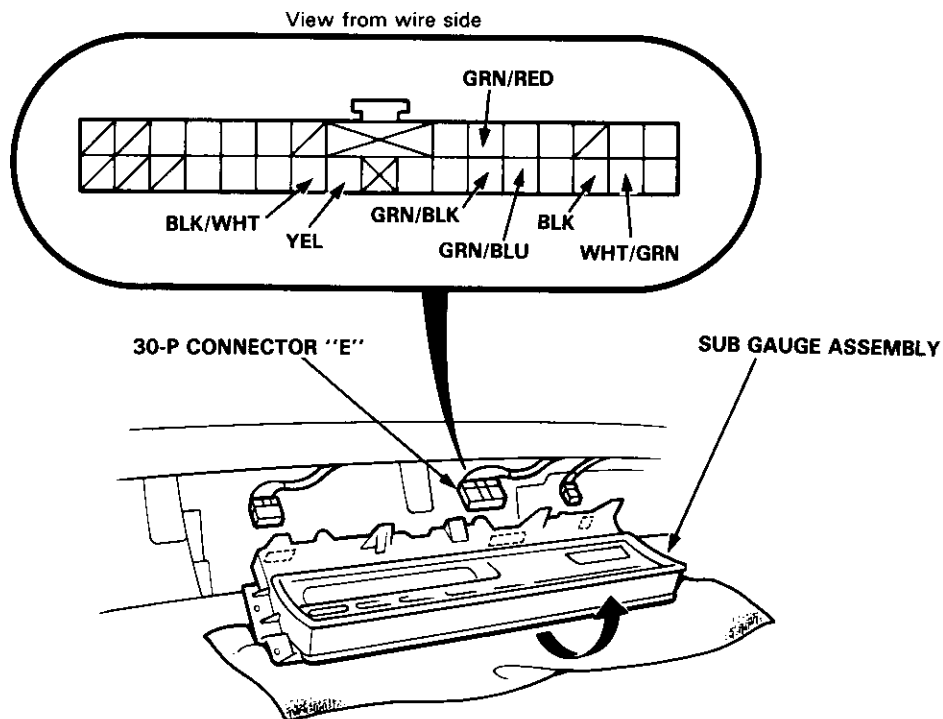
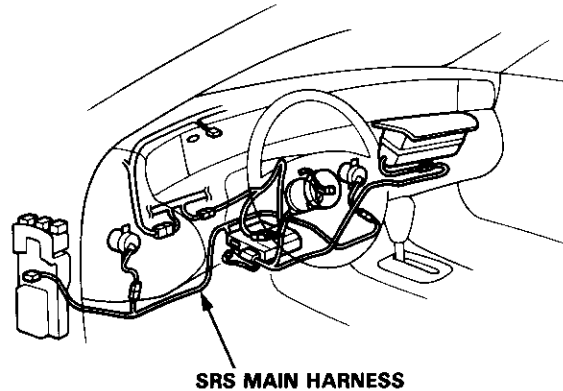



No.	Wire	Test condition	Test: Desired result	Possible cause if result is not obtained
1	BLK	Under all conditions.	Check for continuity to ground: There should be continuity.	• Poor ground (G401, G402, G404).
2	YEL	Ignition switch ON.	Check for voltage to ground: There should be battery voltage.	• Blown No. 13 (10 A) fuse. (In the under-dash fuse/relay box) • An open in the wire.
3	WHT/GRN	Brake pedal pushed.	Check for continuity to ground: There should be less than 4 k Ω .	• Blown No. 41 (15 A) fuse. • Faulty brake switch. • Blown brake light bulb. • Faulty brake light failure sensor. • Poor ground (G521, G551). • An open in the wire.
4	GRN/BLK	Trunk lid open.	Check for continuity to ground: There should be continuity. NOTE: Before testing, remove No. 46 (15 A) fuse in the under-hood fuse/relay box.	• Faulty trunk latch switch. • Poor ground (G521). • An open in the wire.
5	BLK/WHT	Ceiling light switch in MIDDLE position.	Connect to ground: Ceiling light should come on.	• Blown No. 46 (15 A) fuse. • Faulty ceiling light. • An open in the wire.
6	GRN/BLU	Driver's door open.	Check for continuity to ground: There should be continuity. NOTE: Before testing, remove No. 44 (15 A) and No. 46 (15 A) fuses in the under-hood fuse/relay box.	• Faulty door switch. • An open in the wire.
	GRN/RED	Passenger's door open.		

Safety Indicator

Troubleshooting

NOTE: The numbers in the table show the troubleshooting sequence.

Item to be inspected	Blown No. 13 (10 A) fuse (In the under-dash fuse/relay box)	Blown No. 46 (15 A) fuse (In the under-hood fuse/relay box)	Safety indicator input test	Blown bulb	Brake light failure sensor	Door switch	Trunk latch switch	Poor ground	Open circuit, loose or disconnected terminals
Symptom									
No indicators operate.	1		2					G401 G402 G404	YEL
Indicator lights do not come on when the ignition switch is turned to ON.			1	2					
Door indicator light does not come on with doors open.			2	3		1			GRN/BLK GRN/RED
Trunk indicator light does not come on with trunk lid open.			2	3			1	G521	GRN/BLK
Brake indicator light does not come on with blown brake light bulb.			1	3	2				WHT/GRN or GRN
Brake indicator light remains on with good brake light bulbs.			2		1			G551	
Ceiling light does not come on with door open (with switch in MIDDLE position).		1	2	3					BLK/WHT



Brake Light Failure Sensor Test

1. First make sure the brake lights come on when the brake pedal is pressed.
 - If all the brake lights come on, go to step 2.
 - If one of the brake lights does not come on, check whether the bulb is blown. If the bulb is OK, go to step 2.
 - If none of the brake lights come on, check the brake light circuit (see page 23-153).
2. Open the trunk lid and the taillight access panel to the right taillight. Remove the bulb socket housing. Watch the **BRAKE LAMP** light in the safety indicator, when the B (WHT/GRN) wire of the 4-P connector is grounded and the ignition switch is turned from OFF to ON.

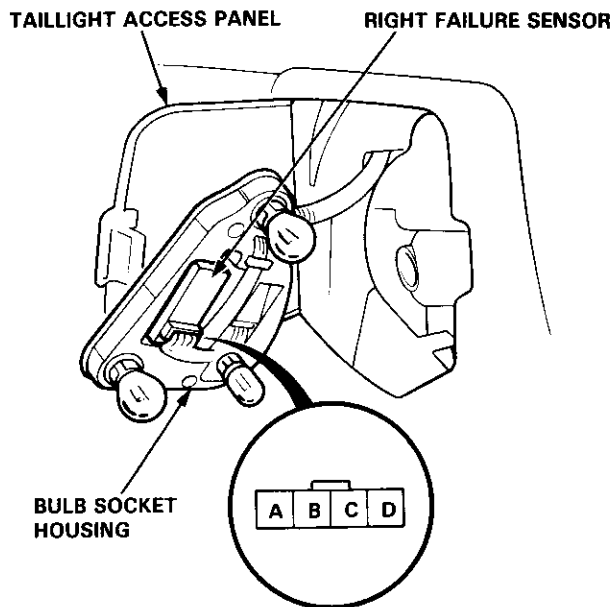

- If the **BRAKE LAMP** light comes on and stays on, check for an open in the B (WHT/GRN) wire between the safety indicator and the right failure sensor.
 - If the **BRAKE LAMP** light does not stay on, go to step 3.
3. Watch the **BRAKE LAMP** light when the ignition switch is turned from OFF to ON with the D (GRN) wire of the 4-P connector grounded and the brake pedal pressed.
 - If the **BRAKE LAMP** light comes on and stays on, replace the right failure sensor.
 - If the **BRAKE LAMP** light does not stay on, go to step 4.

4. Open the taillight access panel to the left taillight. Remove the bulb socket housing. Watch the **BRAKE LAMP** light when the ignition switch is turned from OFF to ON with the B (GRN) wire of the 6-P connector grounded and the brake pedal pressed.

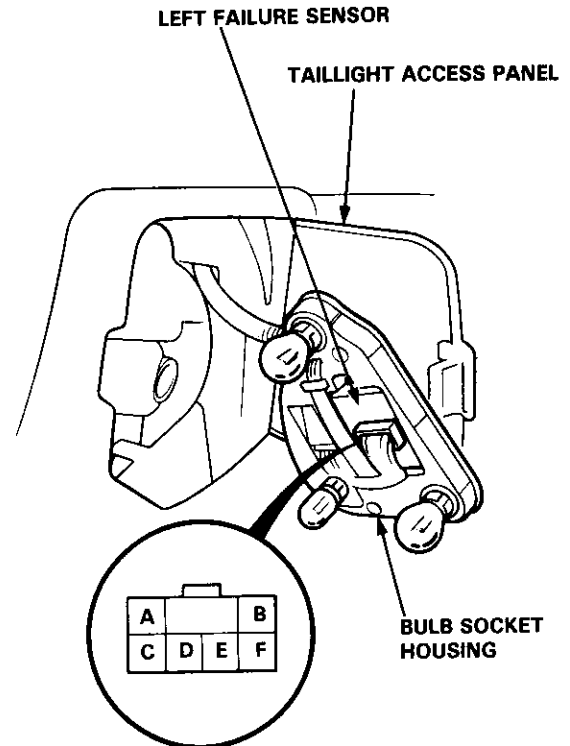

- If the **BRAKE LAMP** light comes on and stays on, there is an open in the B (GRN) wire between the left failure sensor and the right failure sensor.
 - If the **BRAKE LAMP** light does not stay on, go to step 5.
5. Watch the **BRAKE LAMP** light when the ignition switch is turned from OFF to ON with the F (BLK) wire of the 6-P connector grounded and the brake pedal pressed.
 - If the **BRAKE LAMP** light comes on and stays on, replace the left failure sensor.
 - If the **BRAKE LAMP** light does not stay on, check for an open in the F (BLK) wire between the left failure sensor and ground, and check for a poor ground at G551.

Interlock System

Component Location Index

CAUTION:

- All SRS electrical wiring harnesses are covered with yellow outer insulation.
- Before disconnecting the SRS wire harness, install the short connector(s) on the airbag(s), then disconnect the wire harness (see page 23-294).
- Replace the entire affected SRS harness assembly if it has an open circuit or damaged wiring.
- After installing the gauge assembly, recheck the operation of the SRS indicator light.

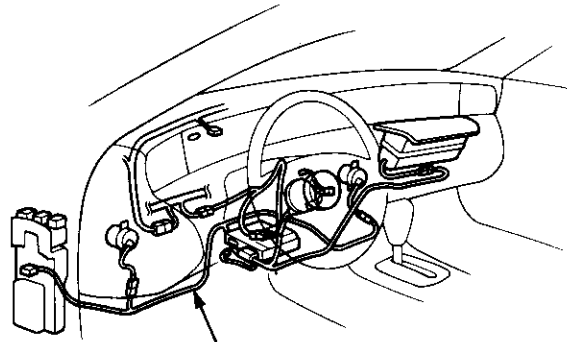

SRS MAIN HARNESS

A/T GEAR POSITION INDICATOR

See page 23-144

INTERLOCK CONTROL UNIT

Input Test, page 23-161

KEY INTERLOCK SOLENOID
and KEY INTERLOCK SWITCH
(In the steering lock assembly)
Test, page 23-162

SHIFT LOCK SOLENOID

Test, page 23-163
Replacement, page 23-163

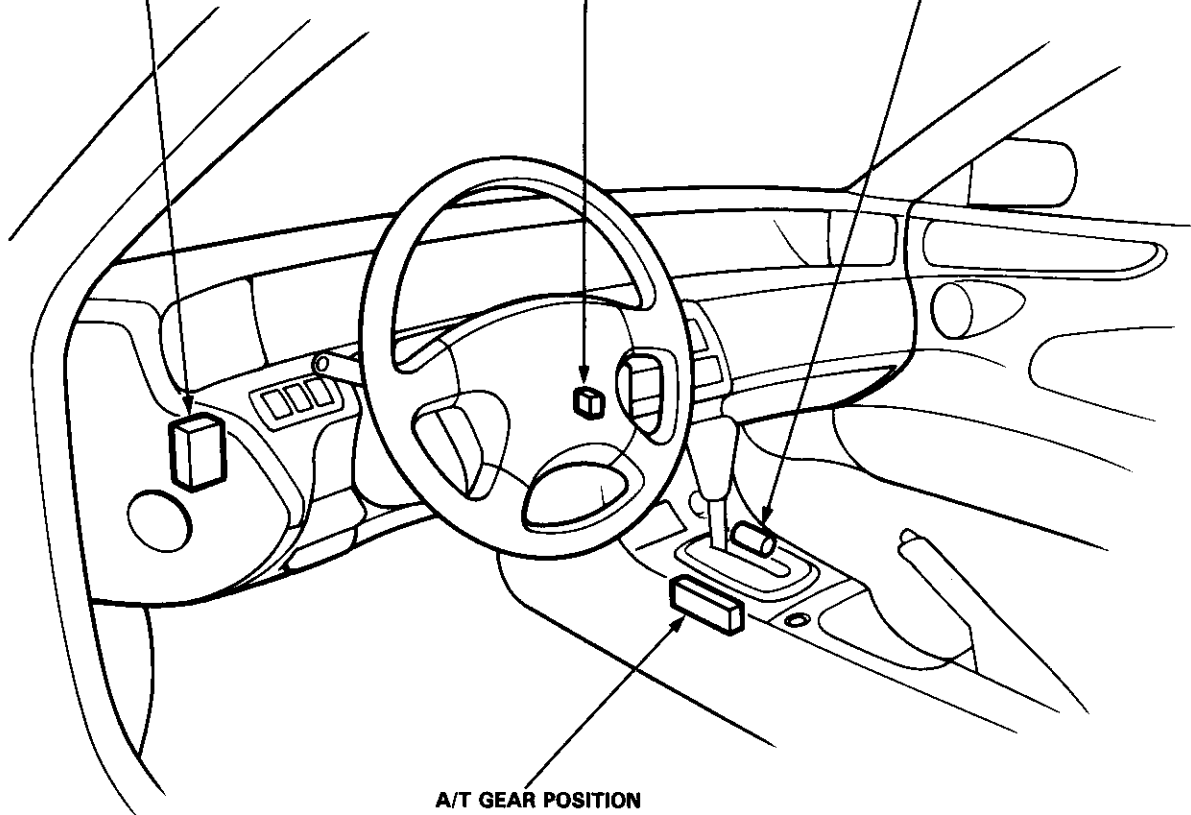

A/T GEAR POSITION SWITCH

Test, page 23-148
Replacement, page 23-149



Description

The car is equipped with the following devices to prevent inadvertent shifting:

- Shift lever with shift lock
- Key cylinder with interlocked ignition key

Shift Lock System:

The shift lock system prevents the shift lever from moving to **R** or **D** from the **P** unless you step on the brake pedal.

NOTE:

- The shift lever cannot be shifted when the brake pedal and the accelerator are stepped on at the same time.
- In case of system malfunction, the shift lever can be released by pushing a key into the release slot near the shift lever.

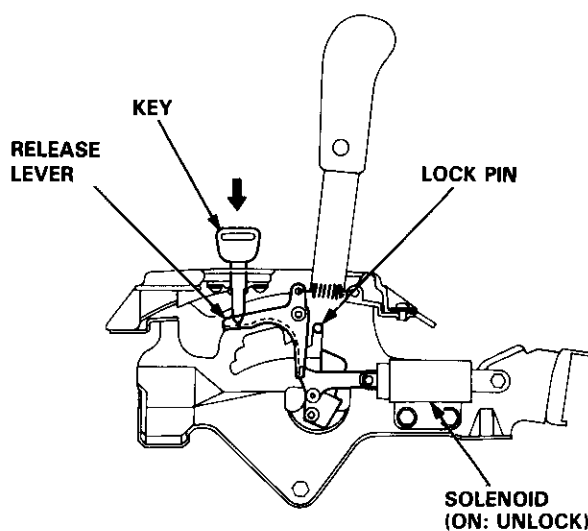
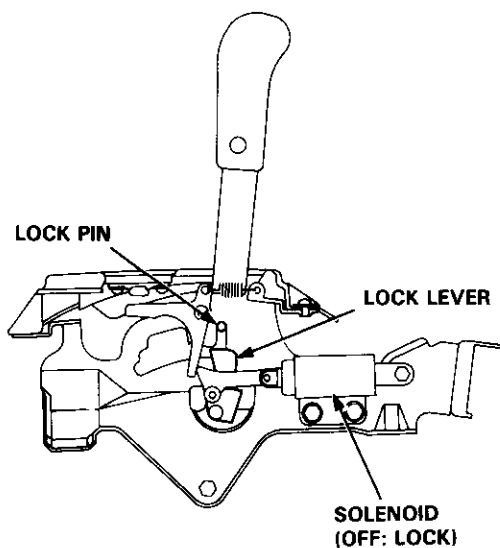

Key Interlock System:

The ignition key cannot be removed from the ignition switch unless the shift lever is in **P**. When the shift lever is in any position other than **P**, a solenoid is activated, making it impossible for the key to be removed until the lever is moved to the **P**.

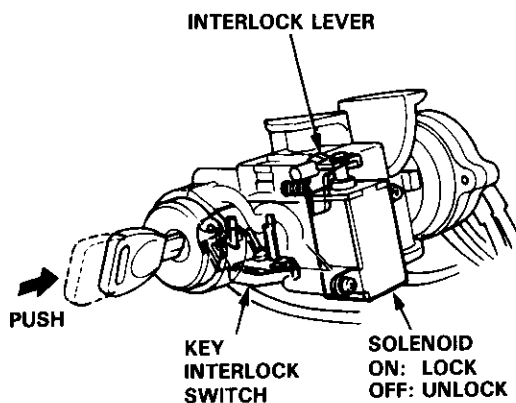

The shift lever is in **P**

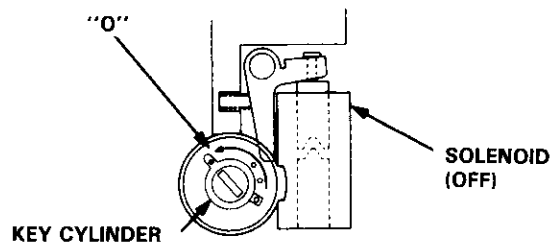

The shift lever is in any position except **P**

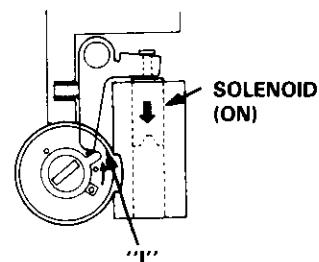

Interlock System

Circuit Diagram

NOTE: Different wires with the same color have been given a number suffix to distinguish them (GRN/WHT¹ and GRN/WHT² are not the same).

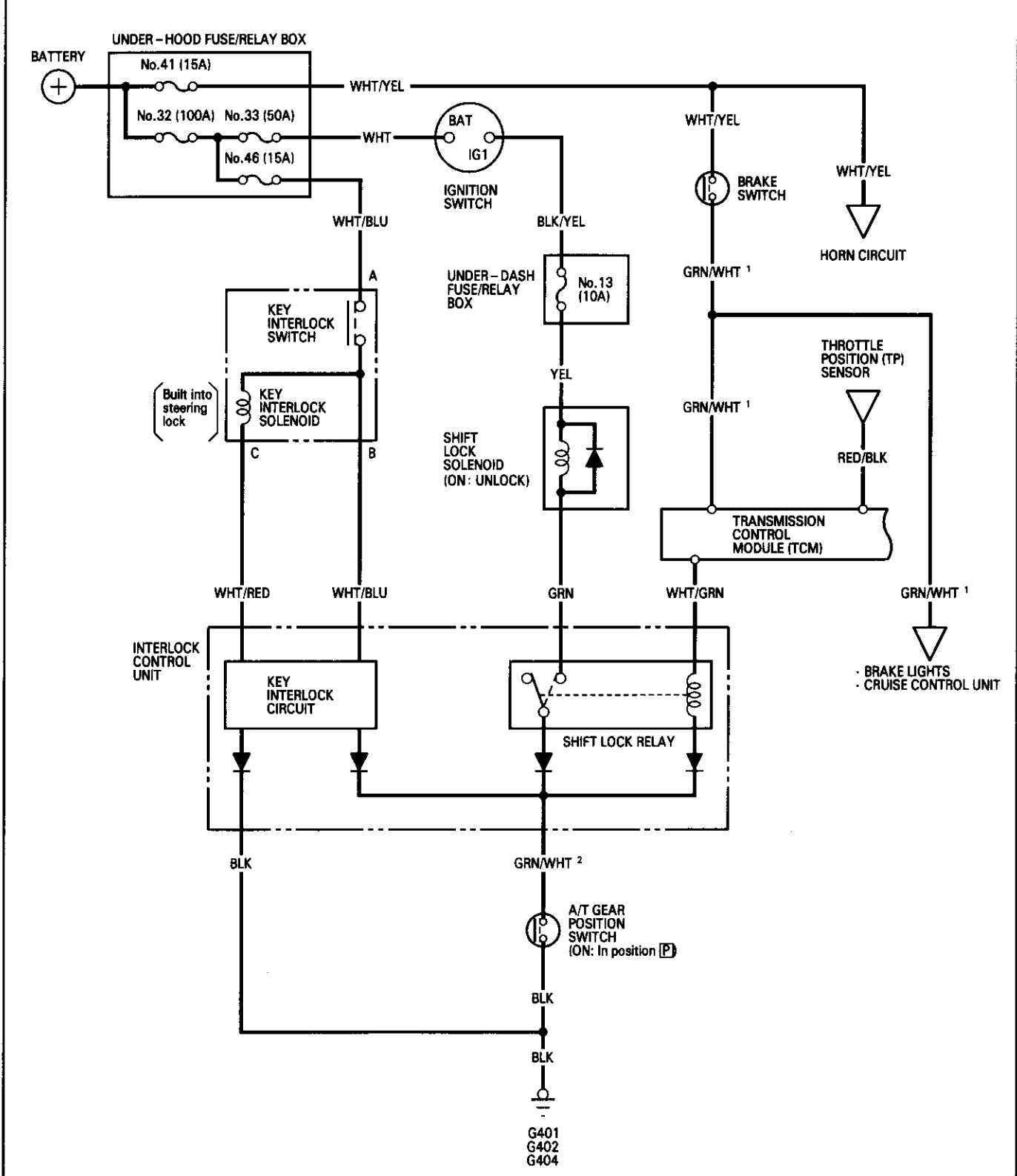



Control Unit Input Test

Disconnect the 8-P connector from the interlock control unit.

Inspect the connector and socket terminals to be sure they are all making good contact.

- If the terminals are bent, loose, or corroded, repair them as necessary, and recheck the system.
- If the terminals look OK, make the following input tests at the connector.
 - If a test indicates a problem, find and correct the cause, then recheck the system.
 - If all the input tests prove OK, substitute a known-good control unit and recheck the system. If the check is OK, the control unit must be faulty; replace it.

NOTE: If the shift lock solenoid clicks when the ignition switch is turned ON and you step on the brake pedal (with the shift lever in **[P]**), the shift lock system is electronically normal; if the shift lever cannot be shifted from **[P]**, test the A/T gear position switch as described on page 23-148 and see section 14.

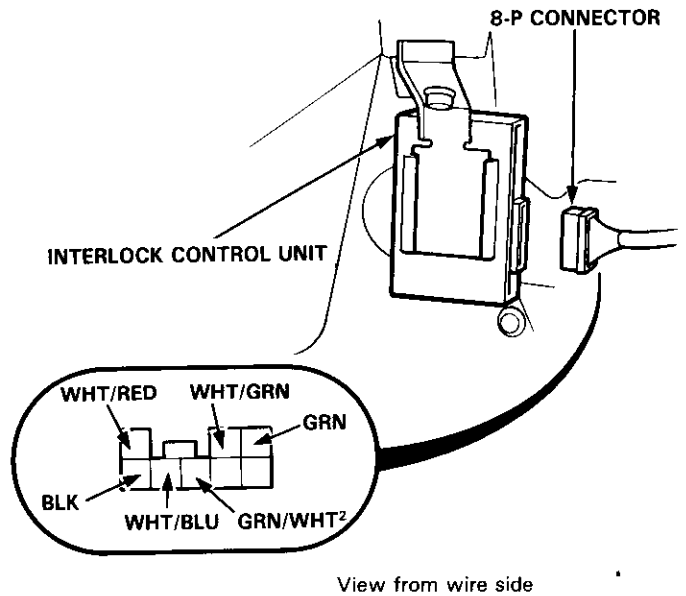

Shift Lock System:

No.	Wire	Test condition	Test: Desired result	Possible cause if result is not obtained
1	WHT/GRN	Ignition switch ON. Brake pedal pushed.	Check for voltage to ground: There should be battery voltage.	<ul style="list-style-type: none"> • Blown No. 41 (15 A) fuse. • Faulty ECM. • Faulty brake switch. • Faulty throttle position (TP) sensor. • An open in the wire.
		Ignition switch ON, brake pedal and ac- celerator pushed at the same time.	Check for voltage to ground: There should be less than bat- tery voltage.	
2	GRN/WHT ²	Shift lever in [P] .	Check for continuity to ground: There should be continuity.	<ul style="list-style-type: none"> • Faulty A/T gear position switch. • Poor ground (G401, G402, G404). • An open in the wire.
3	GRN	Ignition switch ON.	Check for voltage to ground: There should be battery voltage.	<ul style="list-style-type: none"> • Blown No. 13 (10 A) fuse. • Faulty shift lock solenoid. • An open in the wire.

Key Interlock System:

No.	Wire	Test condition	Test: Desired result	Possible cause if result is not obtained
1	BLK	Under all conditions.	Check for continuity to ground: There should be continuity.	<ul style="list-style-type: none"> • Poor ground (G401, G402, G404). • An open in the wire.
2	GRN/WHT ²	Shift lever in [P] .	Check for continuity to ground: There should be continuity.	<ul style="list-style-type: none"> • Faulty A/T gear position switch. • Poor ground (G401, G402, G404). • An open in the wire.
3	WHT/RED	Ignition switch turned to ACC (I) and the key pushed all the way in.	Check for voltage to ground: There should be battery voltage.	<ul style="list-style-type: none"> • Blown No. 46 (10 A) fuse. • Faulty steering lock assembly (key interlock solenoid). • An open in the wire.
	WHT/BLU			

Interlock System

Key Interlock Solenoid Test

CAUTION:

- All SRS electrical wiring harnesses are covered with yellow outer insulation.
- Before disconnecting the SRS wire harness, install the short connector(s) on the airbag(s) (see page 23-294).
- Replace the entire affected SRS harness assembly if it has an open circuit or damaged wiring.

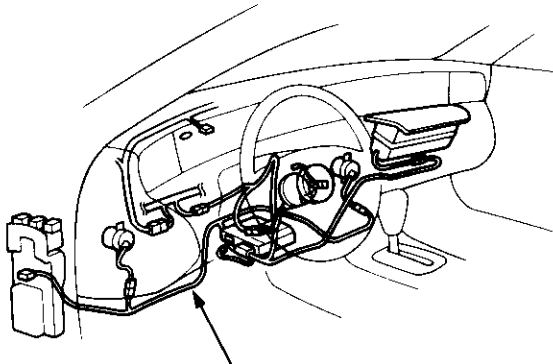

SRS MAIN HARNESS

1. Remove the dashboard lower cover and knee bolster.
2. Disconnect the 8-P connector from the main wire harness.

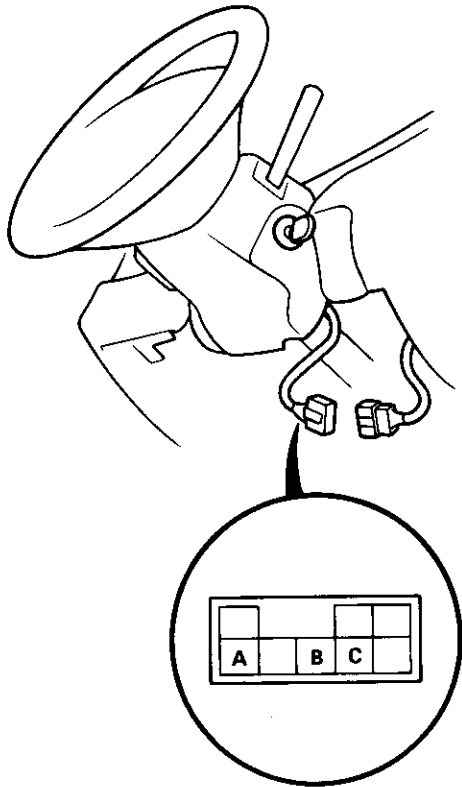

View from wire side

3. Check for continuity between the terminals in each switch position according to the table.

Terminal		A	B	C
Position				
Ignition switch ACC (I)	Key pushed in.	○	○	○
	Key released.		○	○

4. Check that the key cannot be removed with power and ground connected to the A and C terminals.
 - If the key cannot be removed, the key interlock solenoid is OK.
 - If the key can be removed, replace the steering lock assembly (the key interlock solenoid is not available separately).



Shift Lock Solenoid Test/Replacement

Test:

1. Remove the console, then disconnect the 3-P connector of the shift lock solenoid from the main wire harness.

NOTE: Do not connect power to the B (-) terminal (reverse polarity) or you will damage the diode inside the solenoid.

2. Connect battery power to the A terminal and ground to the B terminal momentarily. Check the solenoid to see if it works. If it does not work, replace it.

NOTE:

- When the shift lock solenoid is ON, check that there is a clearance of 2.9 ± 0.5 mm (0.114 ± 0.020 in) between the top corner of the shift lock lever and the lock pin groove (see clearance check on this page).
- When the shift lock solenoid is OFF, make sure that the lock pin is blocked by the shift lock lever.
- If it is not, adjust the position of the shift lock solenoid.

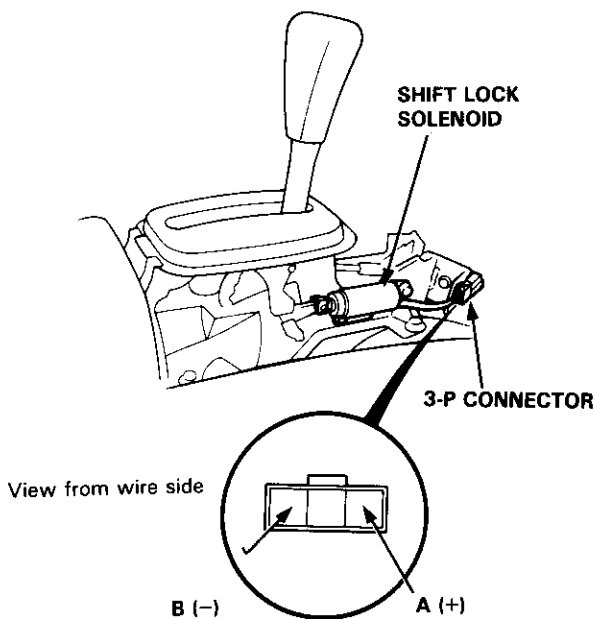

Replacement:

1. Remove the solenoid pin.
2. Remove the self-locking nuts and shift lock solenoid.

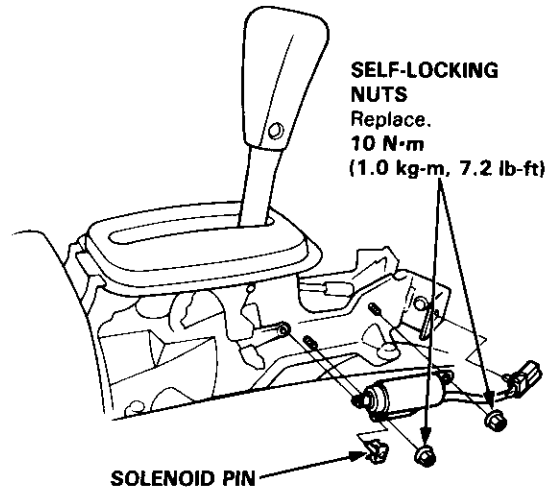

3. Install the new shift lock solenoid in the reverse order of removal and adjust its position.
 - When the shift lock solenoid is ON, check that there is a clearance of 2.9 ± 0.5 mm (0.114 ± 0.020 in) between the top corner of the shift lock lever and the lock pin groove, and tighten the self-locking nuts.

NOTE: Use brand-new self-locking nuts.

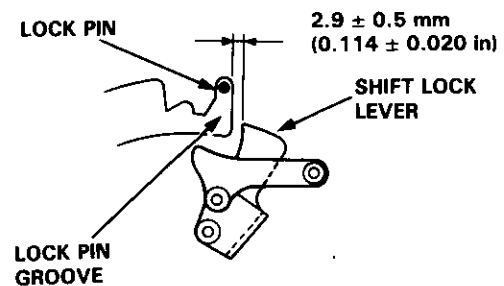

- When the shift lock solenoid is OFF, make sure that the lock pin is blocked by the shift lock lever.

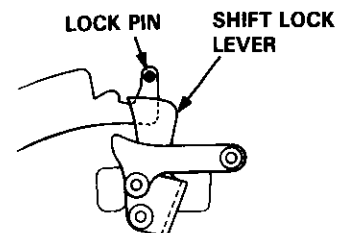

Integrated Control Unit

Circuit Diagram

Description

An integrated control unit, located in the left kick panel, integrates the functions of the key – in/seat belt reminder, side marker light flasher, wiper/washer, lights – on reminder, rear window defogger timer, entry light timer, power window key – off timer, and engine oil pressure indicator flasher circuits.

NOTE: Different wires with the same color have been given a number suffix to distinguish them (for example, GRN/RED¹ and GRN/RED² are not the same).

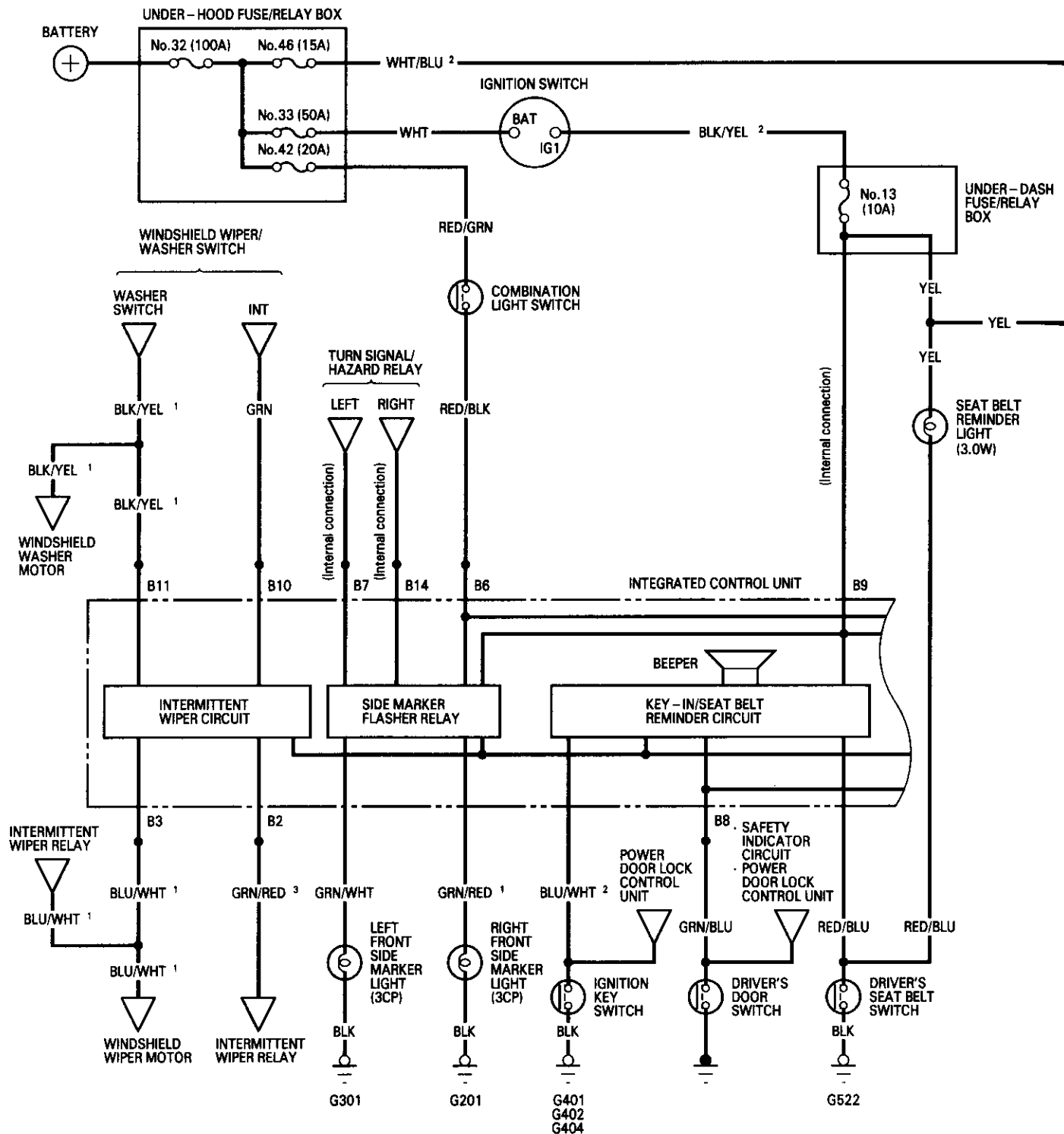

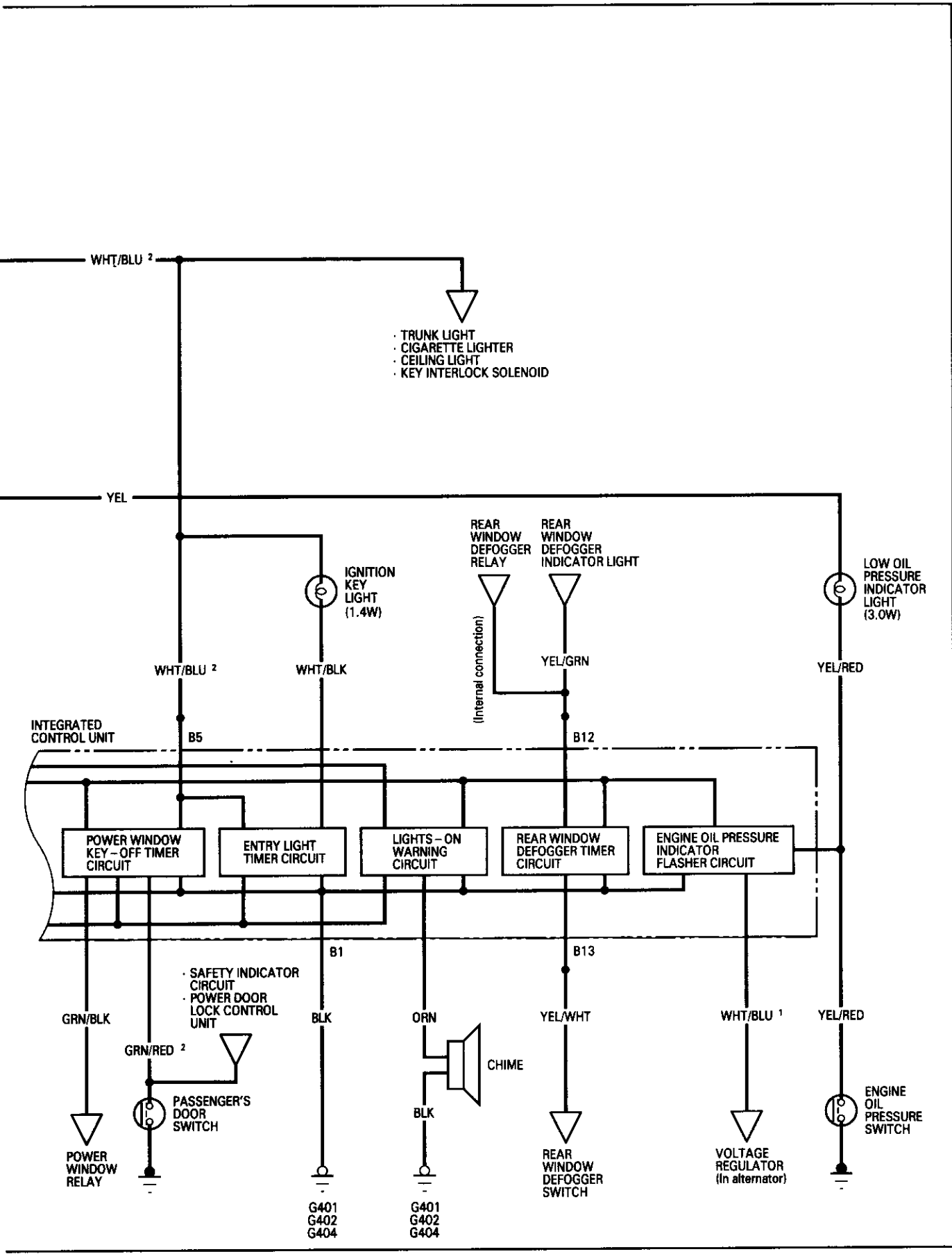

Integrated Control Unit

Input Test

CAUTION:

- All SRS electrical wiring harnesses are covered with yellow outer insulation.
- Before disconnecting the SRS wire harness, install the short connector(s) on the airbag(s) (see page 23-294).
- Replace the entire affected SRS harness assembly if it has an open circuit or damaged wiring.

1. Remove the left kick panel, then disconnect the 16-P connector from the integrated control unit.
2. Remove the under-dash fuse/relay box, then remove the integrated control unit.
3. Inspect the connector and the socket terminals to be sure they are all making good contact.

- If the terminals are bent, loose, or corroded, repair them as necessary, and recheck the system.
- If the terminals look OK, make the following input tests at the connector and the socket.
 - If a test indicates a problem, find and correct the cause, then recheck the system.
 - If all the input tests prove OK, the control unit must be faulty; replace it.

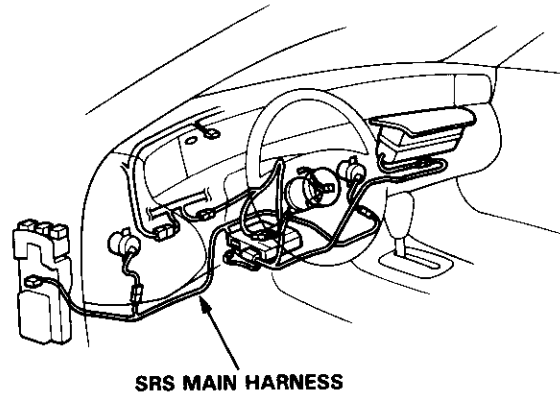

NOTE:

- Different wires with the same color have been given a number suffix to distinguish them (for example, GRN/RED¹ and GRN/RED² are not the same).
- Do not disconnect any connectors from the under-dash fuse/relay box except the one for the integrated control unit.

View from terminal side

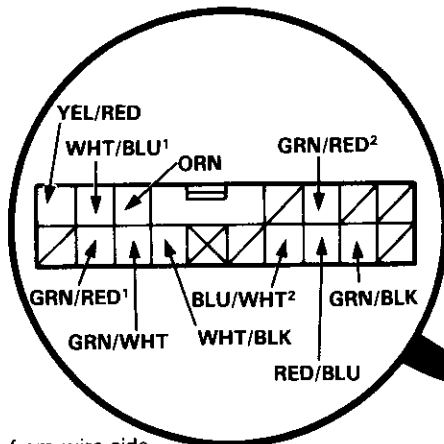
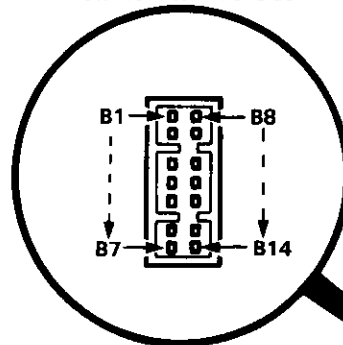

View from wire side

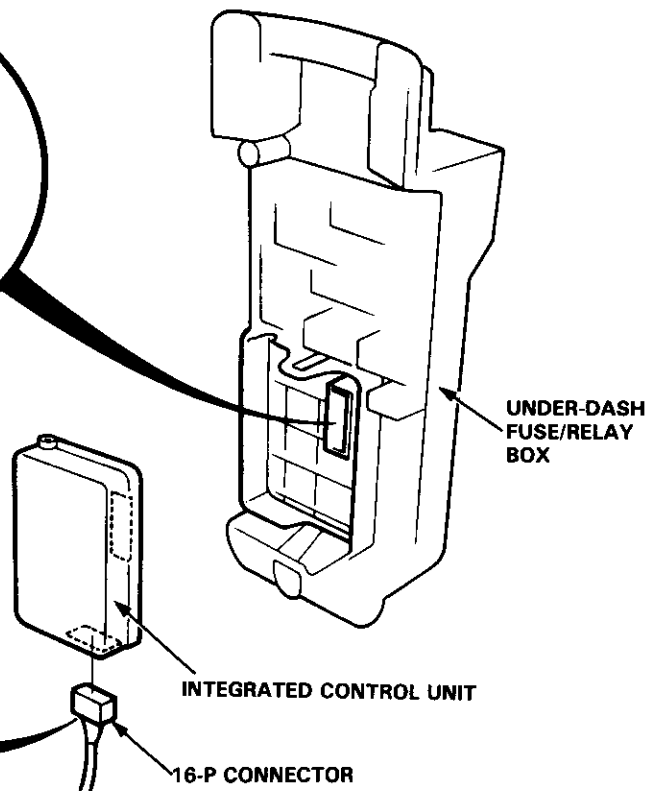

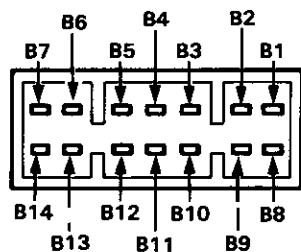

View from terminal side of the under-dash fuse/relay box socket

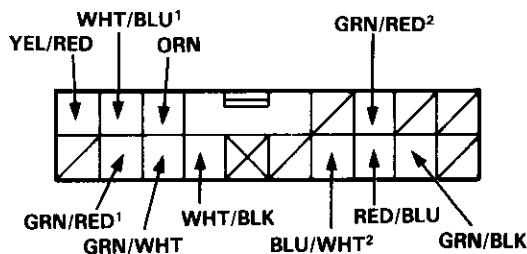

View from wire side of the harness connector

Wiper System:

No.	Terminal	Test condition	Test: Desired result	Possible cause if result is not obtained
1	B1	Under all conditions.	Check for continuity to ground: There should be continuity.	<ul style="list-style-type: none"> • Poor ground (G401, G402, G404). • An open in the wire.
2	B2	Ignition switch ON.	Check for voltage to ground: There should be battery voltage.	<ul style="list-style-type: none"> • Blown No. 17 (30 A) fuse. (In the under-dash fuse/relay box) • Faulty intermittent wiper relay. • An open in the wire.
3	B10	Ignition switch ON and wiper switch at INT position.	Check for voltage to ground: There should be battery voltage.	<ul style="list-style-type: none"> • Blown No. 17 (30 A) fuse. (In the under-dash fuse/relay box) • Faulty wiper switch. • An open in the wire.
4	B11	Ignition switch ON and washer switch ON.	Check for voltage to ground: There should be battery voltage.	<ul style="list-style-type: none"> • Blown No. 17 (30 A) fuse. (In the under-dash fuse/relay box) • Faulty wiper switch. • An open in the wire.
5	B3	Ignition switch ON.	Check for voltage to ground: There should be battery voltage.	<ul style="list-style-type: none"> • Blown No. 17 (30 A) fuse. (In the under-dash fuse/relay box) • Faulty intermittent wiper relay. • Faulty windshield wiper motor. • An open in the wire.

Engine Oil Pressure Indicator Flasher System:

No.	Terminal	Test condition	Test: Desired result	Possible cause if result is not obtained
1	B1	Under all conditions.	Check for continuity to ground: There should be continuity.	<ul style="list-style-type: none"> • Poor ground (G401, G402, G404). • An open in the wire.
2	B9	Ignition switch ON.	Check for voltage to ground: There should be battery voltage.	<ul style="list-style-type: none"> • Blown No. 13 (10 A) fuse. (In the under-dash fuse/relay box) • An open in the wire.
3	B6	Headlight switch ON.	Check for voltage to ground: There should be battery voltage.	<ul style="list-style-type: none"> • Blown No. 42 (20 A) fuse. (In the under-hood fuse/relay box) • Faulty combination light switch. • An open in the wire.
4	B7	Ignition switch ON and turn signal switch to "Left".	Check for voltage to ground: It should change from 0—12—0 V repeatedly.	<ul style="list-style-type: none"> • Blown No. 13 (10 A) fuse. (In the under-dash fuse/relay box) • Faulty turn signal/hazard relay. • An open in the wire.
5	B14	Ignition switch ON and turn signal switch to "Right".		
6	GRN/WHT	Connect the B5 terminal to the GRN/WHT (or GRN/RED ¹) terminal.	Check front side marker light operation: Left (or Right) front side marker light should come on as the battery is connected.	<ul style="list-style-type: none"> • Blown bulb. • Poor ground [G301 (or G201)]. • An open in the wire.
7	GRN/RED ¹			

(cont'd)

Integrated Control Unit

Input Test (cont'd)

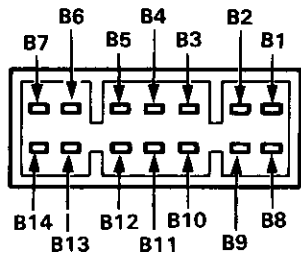

View from terminal side of the under-dash fuse/relay box socket

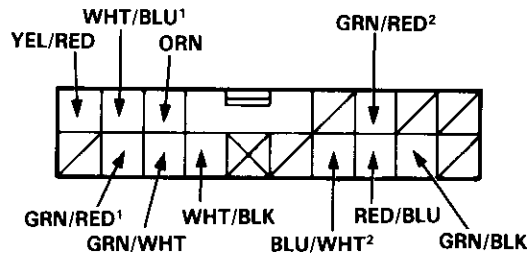

View from wire side of the harness connector

Key-in/Seat Belt Reminder System:

No.	Terminal	Test condition	Test: Desired result	Possible cause if result is not obtained
1	B1	Under all conditions.	Check for continuity to ground: There should be continuity.	<ul style="list-style-type: none"> • Poor ground (G401, G402, G404). • An open in the wire.
2	B8	Driver's door open.	Check for continuity to ground: There should be continuity. NOTE: Before testing, remove No. 46 (15 A) fuse in the under-hood fuse/relay box.	<ul style="list-style-type: none"> • Faulty driver's door switch. • An open in the wire.
3	BLU/WHT ²	Ignition key is inserted into the ignition switch.	Check for voltage to ground: It should be 1 V or less.	<ul style="list-style-type: none"> • Faulty ignition key switch. • Poor ground (G401, G402, G404). • An open in the wire.
4	RED/BLU	Ignition switch ON and driver's seat belt unbuckled.	Check for voltage to ground: It should be 1 V or less.	<ul style="list-style-type: none"> • Faulty seat belt switch. • Poor ground (G522). • An open in the wire.
5	B9	Ignition switch ON.	Check for voltage to ground: There should be battery voltage.	<ul style="list-style-type: none"> • Blown No. 13 (10 A) fuse. (In the under-dash fuse/relay box) • An open in the wire.

Power Window Key-off Timer System:

No.	Terminal	Test condition	Test: Desired result	Possible cause if result is not obtained
1	B1	Under all conditions.	Check for continuity to ground: There should be continuity.	<ul style="list-style-type: none"> • Poor ground (G401, G402, G404). • An open in the wire.
2	B5	Under all conditions.	Check for voltage to ground: There should be battery voltage.	<ul style="list-style-type: none"> • Blown No. 46 (15 A) fuse. (In the under-hood fuse/relay box) • An open in the wire.
3	B8	Driver's door open.	Check for continuity to ground: There should be continuity. NOTE: Before testing, remove No. 46 (15 A) fuse in the under-hood fuse/relay box.	<ul style="list-style-type: none"> • Faulty driver's door switch. • An open in the wire.
4	GRN/RED ²	Passenger's door open.	Check for continuity to ground: There should be continuity. NOTE: Before testing, remove No. 46 (15 A) fuse in the under-hood fuse/relay box.	<ul style="list-style-type: none"> • Faulty door switch. • An open in the wire.
5	GRN/BLK	Connect the B5 terminal to the GRN/BLK terminal.	Check window operation: Power windows should work with the key OFF.	<ul style="list-style-type: none"> • Faulty power window relay. • Poor ground (G401, G402, G404). • An open in the wire.

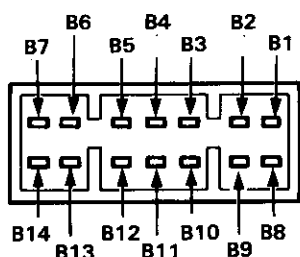

View from terminal side of the under-dash fuse/relay box socket

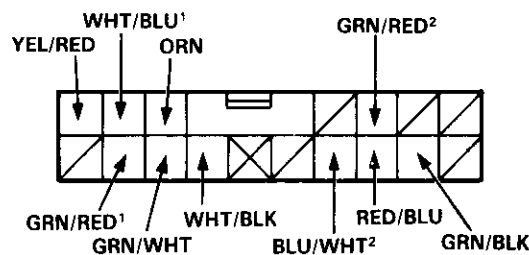

View from wire side of the harness connector

Entry Light Timer System:

No.	Terminal	Test condition	Test: Desired result	Possible cause if result is not obtained
1	B1	Under all conditions.	Check for continuity to ground: There should be continuity.	<ul style="list-style-type: none"> • Poor ground (G401, G402, G404). • An open in the wire.
2	B5	Under all conditions.	Check for voltage to ground: There should be battery voltage.	<ul style="list-style-type: none"> • Blown No. 46 (15 A) fuse. (In the under-hood fuse/relay box) • An open in the wire.
3	WHT/BLK	Under all conditions.	Attach to ground: Ignition key light should come on.	<ul style="list-style-type: none"> • Blown bulb. • An open in the wire.
4	B8	Driver's door open.	Check for continuity to ground: There should be continuity. NOTE: Before testing, remove No. 46 (15 A) fuse in the under-hood fuse/relay box.	<ul style="list-style-type: none"> • Faulty driver's door switch. • An open in the wire.

Lights-on Reminder System:

No.	Terminal	Test condition	Test: Desired result	Possible cause if result is not obtained
1	B1	Under all conditions.	Check for continuity to ground: There should be continuity.	<ul style="list-style-type: none"> • Poor ground (G401, G402, G404). • An open in the wire.
2	B6	Headlight switch ON.	Check for voltage to ground: There should be battery voltage.	<ul style="list-style-type: none"> • Blown No. 42 (20 A) fuse. (In the under-hood fuse/relay box) • Faulty combination light switch. • An open in the wire.
3	B9	Ignition switch ON.	Check for voltage to ground: There should be battery voltage.	<ul style="list-style-type: none"> • Blown No. 13 (10 A) fuse. (In the under-dash fuse/relay box) • An open in the wire.
4	B8	Driver's door open.	Check for continuity to ground: There should be continuity. NOTE: Before testing, remove No. 46 (15 A) fuse in the under-hood fuse/relay box.	<ul style="list-style-type: none"> • Faulty driver's door switch. • An open in the wire.
5	ORN	Ignition switch ON and connect the B9 terminal to the ORN terminal.	Check chime operation: Chime should activate each time the battery is connected.	<ul style="list-style-type: none"> • Faulty chime. • An open in the wire.

(cont'd)

Integrated Control Unit

Input Test (cont'd)

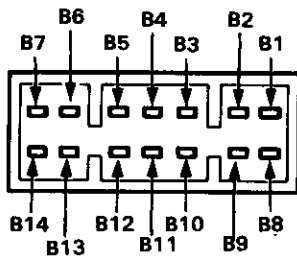

View from terminal side of the under-dash fuse/relay box socket

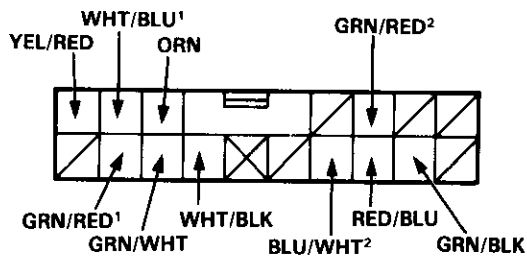

View from wire side of the harness connector

Rear Window Defogger Timer Circuit:

No.	Terminal	Test condition	Test: Desired result	Possible cause if result is not obtained
1	B1	Under all conditions.	Check for continuity to ground: There should be continuity.	<ul style="list-style-type: none"> • Poor ground (G401, G402, G404). • An open in the wire.
2	B13	Defogger switch pushed.	Check for continuity to ground: There should be continuity as the switch is pushed.	<ul style="list-style-type: none"> • Faulty defogger switch. • Poor ground (G401, G402, G404). • An open in the wire.
3	B12	Ignition switch ON.	Attach to ground: Rear window defogger should work and the defogger switch indicator light should come on.	<ul style="list-style-type: none"> • Blown No. 34 (40 A) fuse. (In the under-hood fuse/relay box) • Faulty defogger relay. • Blown LED. • An open in the wire.
4	B9	Ignition switch ON.	Check for voltage to ground: There should be battery voltage.	<ul style="list-style-type: none"> • Blown No. 13 (10 A) fuse. (In the under-dash fuse/relay box) • An open in the wire.

Engine Oil Pressure Indicator Flasher System:

No.	Terminal	Test condition	Test: Desired result	Possible cause if result is not obtained
1	B1	Under all conditions.	Check for continuity to ground: There should be continuity.	<ul style="list-style-type: none"> • Poor ground (G401, G402, G404). • An open in the wire.
2	B9	Ignition switch ON.	Check for voltage to ground: There should be battery voltage.	<ul style="list-style-type: none"> • Blown No. 13 (10 A) fuse. (In the under-dash fuse/relay box) • An open in the wire.
3	WHT/BLU¹	Engine running.	Check for voltage to ground: There should be battery voltage.	<ul style="list-style-type: none"> • Faulty charging system. • An open in the wire.
4	YEL/RED	Ignition switch OFF.	Check for continuity to ground: There should be continuity.	<ul style="list-style-type: none"> • Faulty engine oil pressure switch. • An open in the wire.
		Ignition switch ON.	Check indicator light. If the light does not come on, attach the YEL/RED terminal to ground: The light should come on as the ignition switch is turned ON.	<ul style="list-style-type: none"> • Blown bulb. • An open in the wire.
		Start the engine.	Check for voltage to ground: There should be battery voltage.	<ul style="list-style-type: none"> • Insufficient oil. • Improper lubrication. • Faulty engine oil pressure switch.

Key-in Reminder System

Ignition Key Switch Test

NOTE: Refer to page 23-164 for the diagram of the key-in beeper circuit, and page 23-168 for the input test of the beeper circuit.

When the ignition key is not removed, the key-in beeper in the integrated control unit senses ground through the closed ignition key switch. When you open the driver's door, the beeper circuit senses ground through the closed door switch. With ground at the "BLU/WHT" and "B8" terminals, the beeper sounds.

1. Remove the dashboard lower cover and knee bolster (see page 23-68).
2. Disconnect the 8-P connector from the main wire harness.

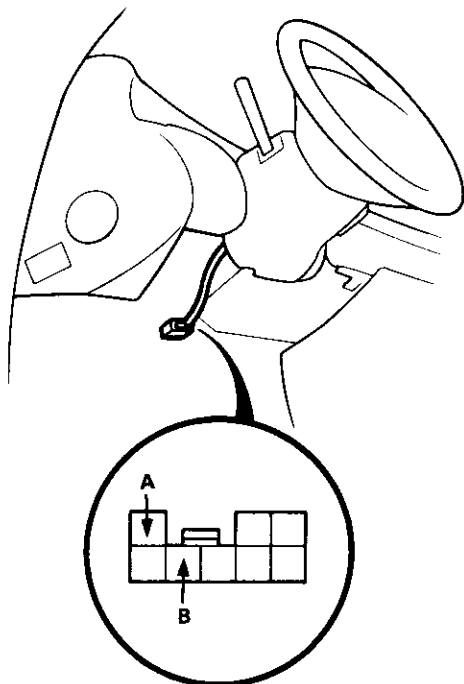

8-P CONNECTOR

3. Check continuity between terminals A and B.
 - There should be continuity with the key in the ignition switch.
 - There should be no continuity with the key removed.

Lights-on Reminder System



Chime Test

NOTE: Refer to page 23-165 for the diagram of the lights-on reminder circuit, and page 23-169 for the input test of the circuit.

When the ignition key is turned to "0" position and removed, with the lights on, voltage is applied to the reminder circuit on the integrated control unit. When you open the driver's door, the circuit senses ground through the closed door switch.

With voltage at the "B6" terminal, ground at the "B8" terminal and no voltage at the "B9" terminal, the chime sounds to remind the driver to turn off the lights.

1. Remove the dashboard lower cover and knee bolster.
2. Disconnect the 2-P connector from the main wire harness.

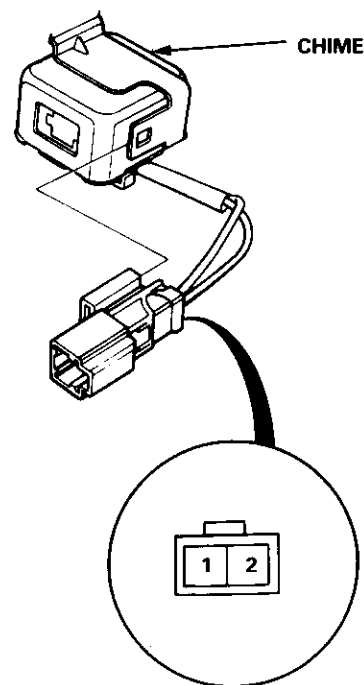

2-P CONNECTOR

3. Test the chime by connecting battery power to No. 1 terminal, grounding to No. 2 terminal, and cycling the power on-off repeatedly.
4. If the chime fails to sound every time power is cycled, replace it.

Seat Belt Reminder System

Description

NOTE: Refer to page 23-164 for the diagram of the seat belt beeper/timer circuit.

With the ignition switch in "Run" or "Start", voltage is applied to the beeper/timer of the integrated control unit. When you unbuckle the driver's seat belt, the beeper/timer circuit senses ground. With voltage at the "B9" terminal and ground at the "RED/BLU" terminal, the seat belt beeper sounds and the timer contacts close and open. This causes the seat belt reminder light to flash on and off. After five seconds the alarm stops and the contacts remain open.

Seat Belt Switch Test

1. Slide the front seat all the way forward then disconnect the 2-P connector from the seat belt switch.

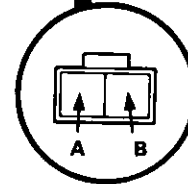
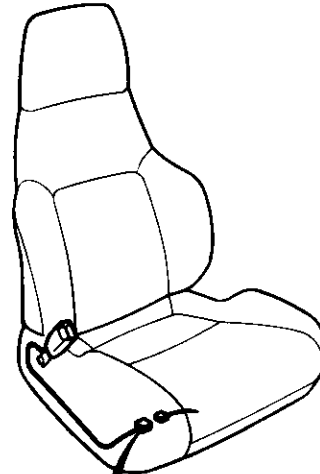

View from
terminal side

2-P CONNECTOR

2. Check continuity between terminals A and B.
 - There should be continuity with the seat belt unbuckled.
 - There should be no continuity with the seat belt is buckled.



Entry Light Timer System

Ignition Key Light Test

1. Remove the dashboard lower cover and knee bolster (see page 23-68).
2. Disconnect the 8-P connector from the main wire harness.

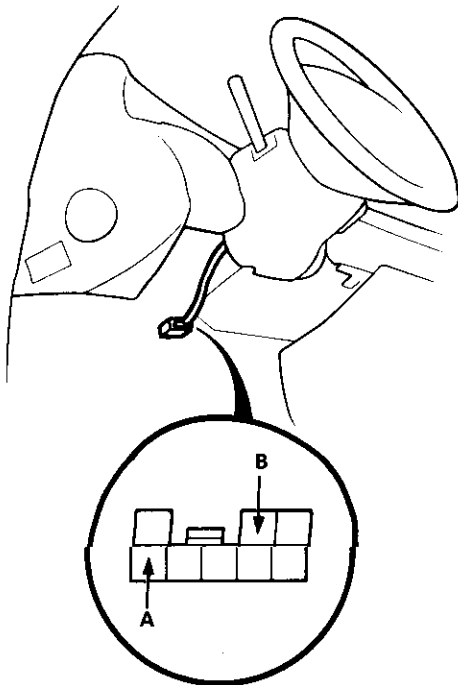

8-P CONNECTOR

3. There should be continuity between the A and B terminals.
If there is no continuity, replace the light.

Ignition Key Light Replacement

1. Remove the steering column covers (see page 23-74).
2. Remove the bulb/socket from the key light housing by turning the socket 45° counterclockwise.

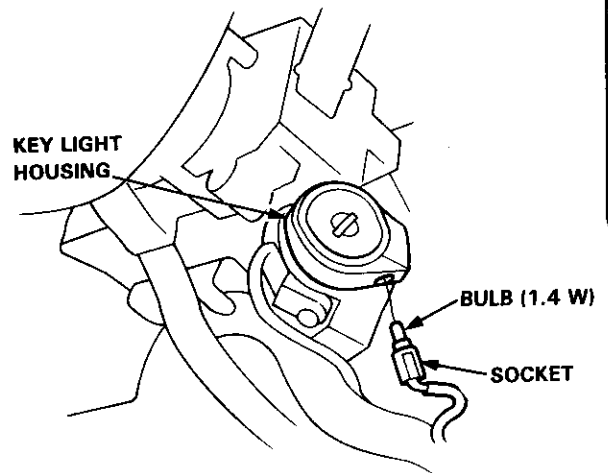

Lighting System

Component Location Index

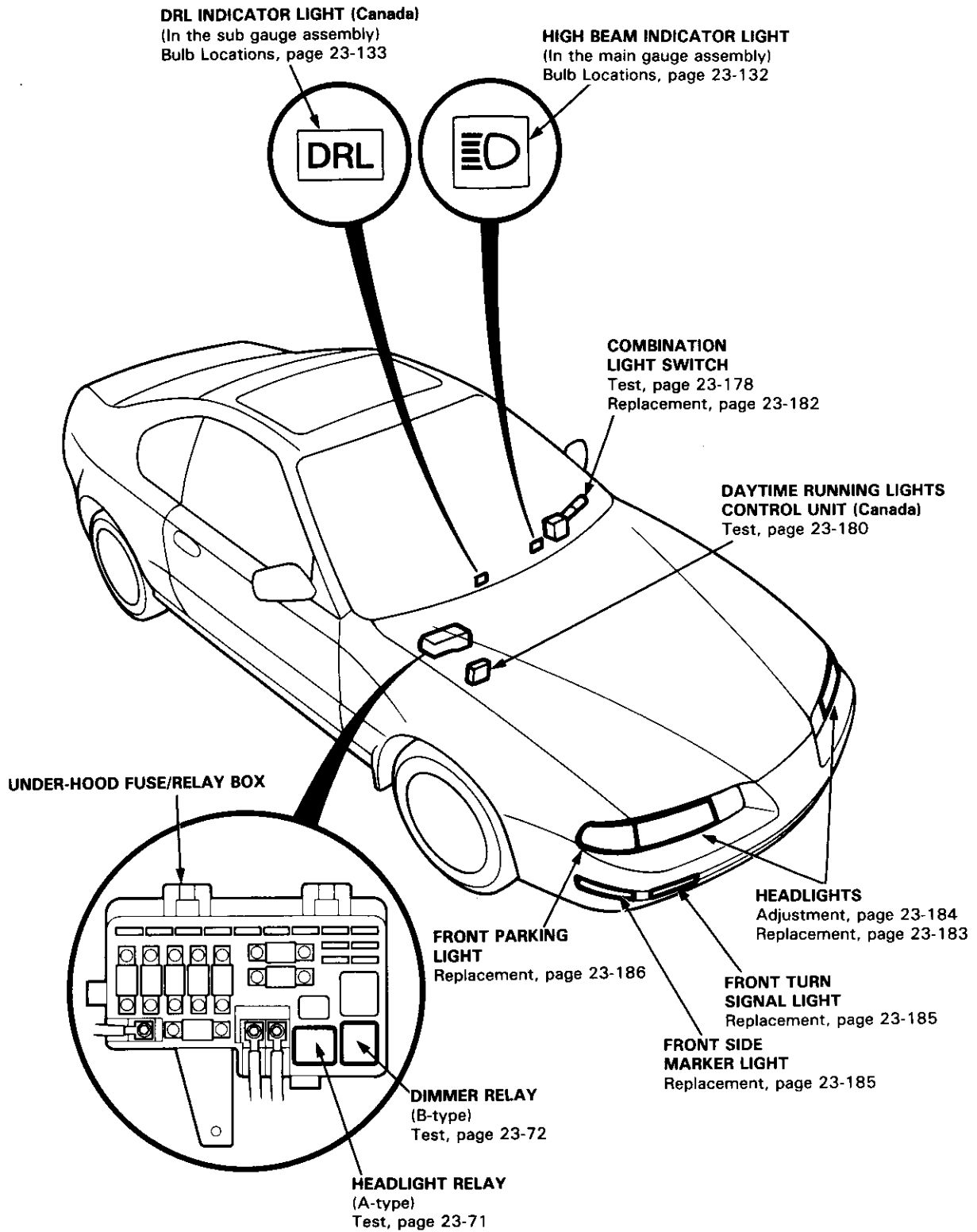

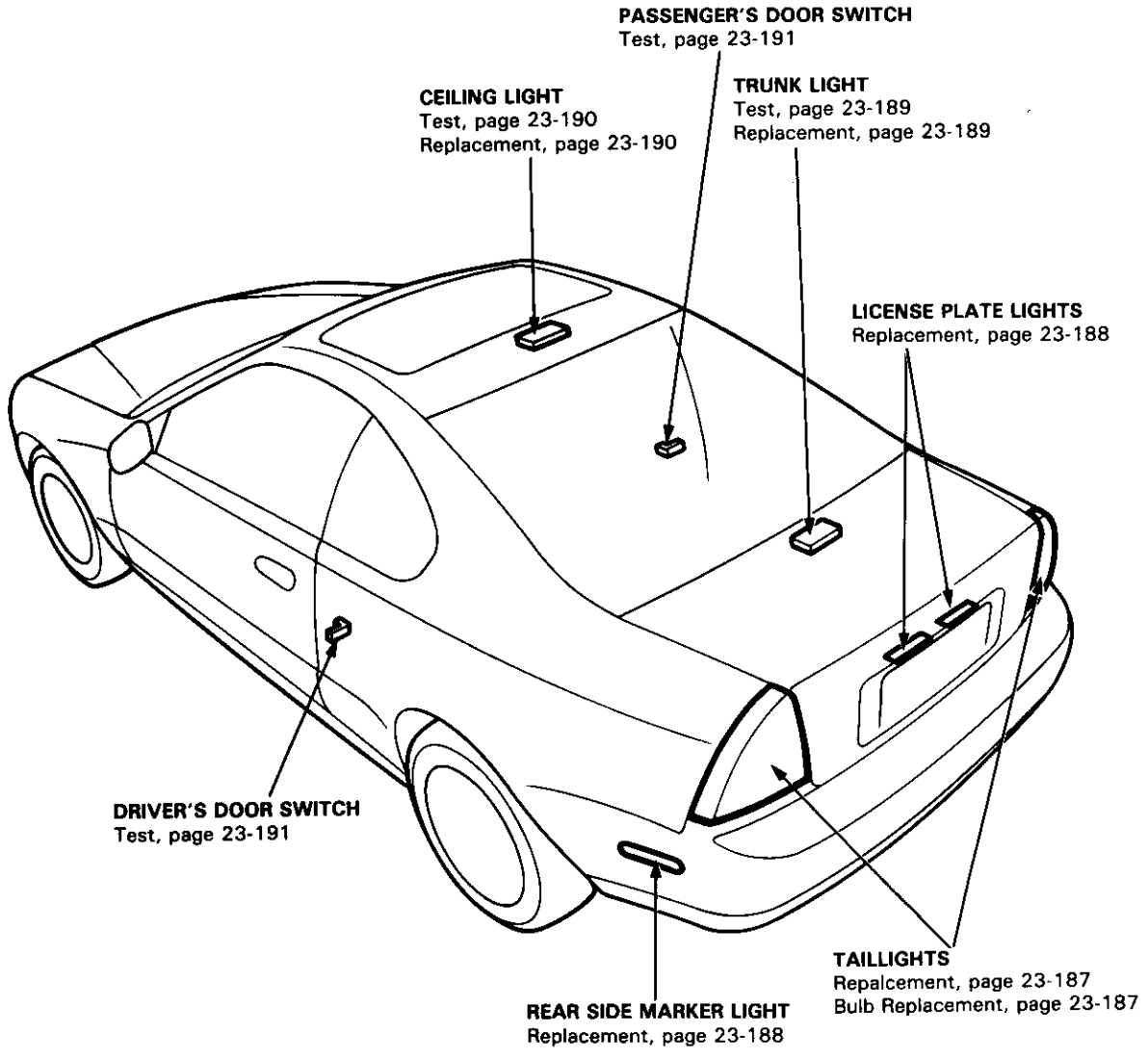

Lighting System

Circuit Diagram (USA)

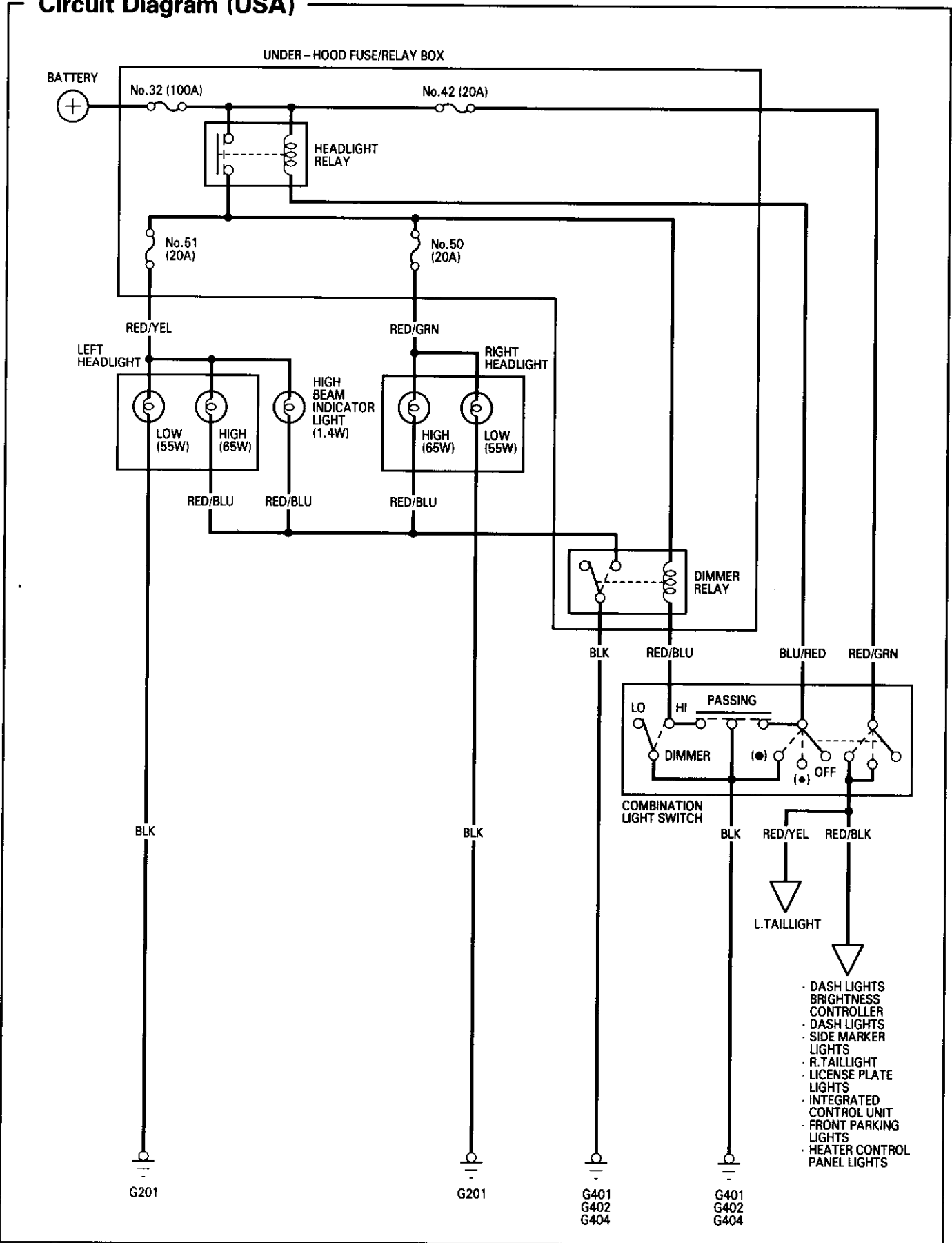



Circuit Diagram (Canada)

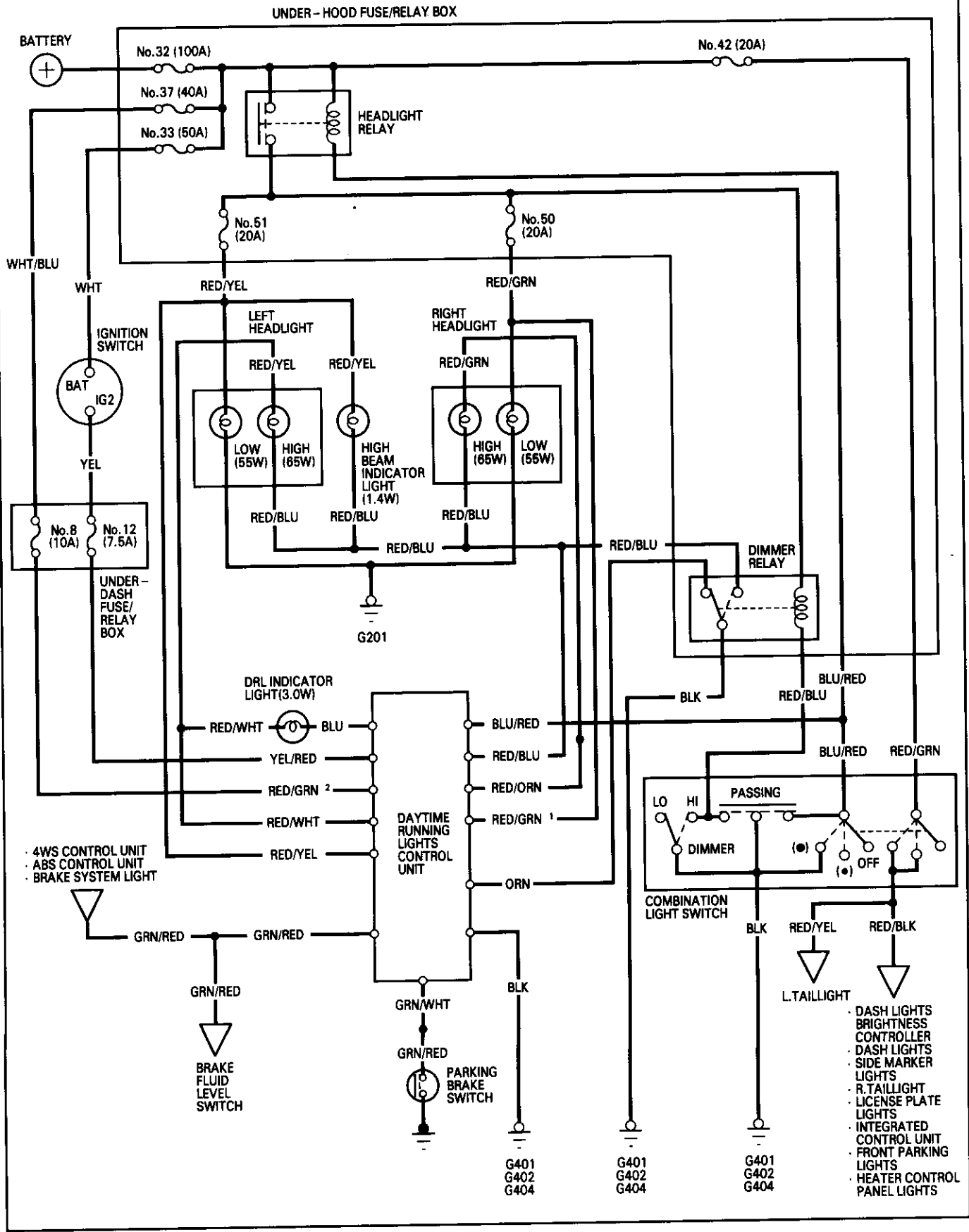

Lighting System

Combination Light Switch Test

CAUTION:

- All SRS electrical wiring harnesses are covered with yellow outer insulation.
- Before disconnecting the SRS wire harness, install the short connector on the airbag (see page 23-294).
- Replace the entire affected SRS harness assembly if it has an open circuit or damaged wiring.

NOTE: The radio may have a coded theft protection circuit. Be sure to get the customer's code number before

- Disconnecting the battery.
- Removing the No. 43 (10 A) fuse.
(In the under-hood fuse/relay box)
- Removing the radio.

After service, reconnect power to the radio and turn it on. When the word "CODE" is displayed, enter the customer's 5-digit code to restore radio operation.

1. Remove the dashboard lower cover and knee bolster.
2. Disconnect the connectors from the main wire harness.
3. Inspect the connector terminals to be sure they are all making good contact.
 - If the terminals are bent, loose, or corroded, repair them as necessary, and recheck the system.
 - If the terminals look OK, check for continuity between them in each switch position according to the tables.

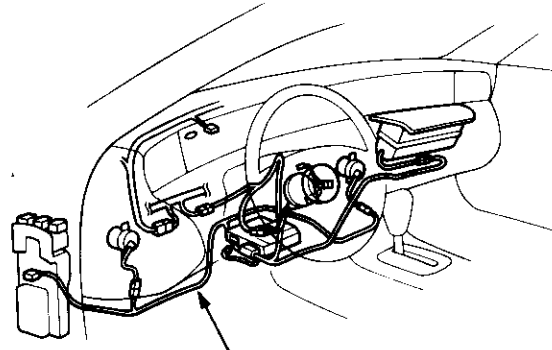

SRS MAIN HARNESS

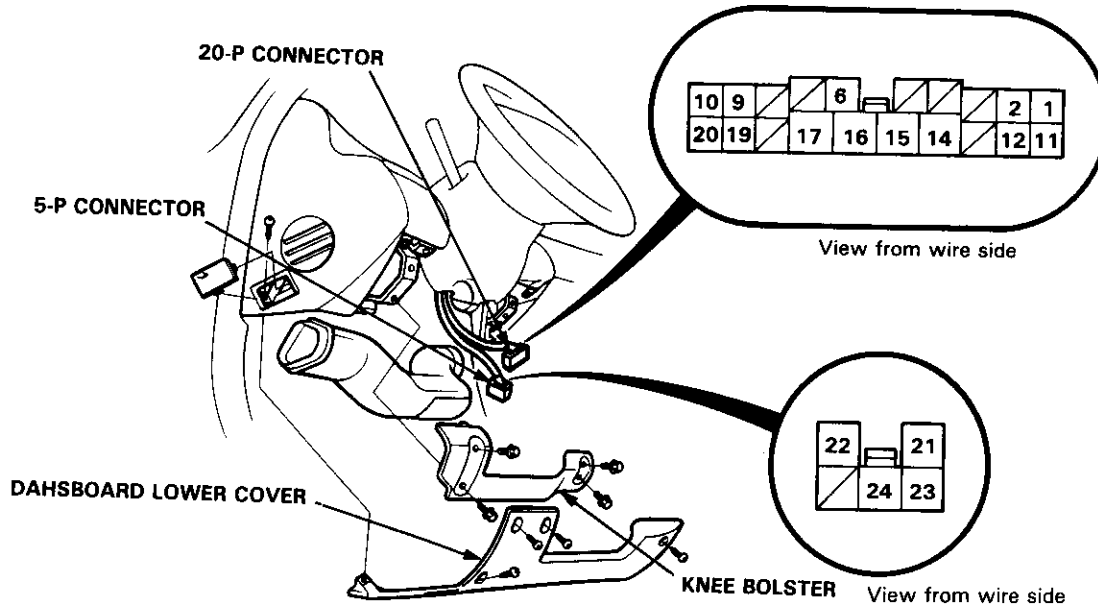



Headlight/Dimmer/Passing Switch

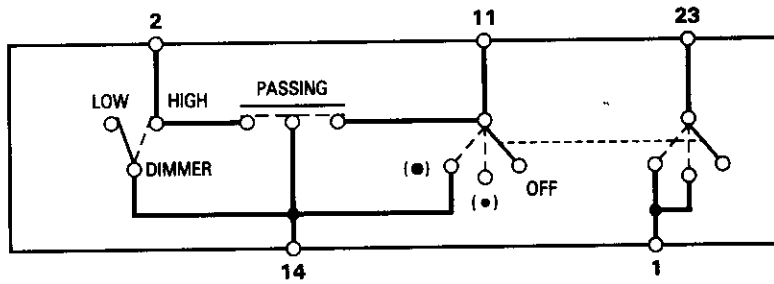

Terminal		1	2	11	14	23
Headlight switch	OFF					
	•	○				○
	LOW	○			○	○
	HIGH	○	○	○	○	○
Passing switch (Headlight switch "OFF")	OFF					
	ON		○		○	
Passing switch (Headlight switch "•")	OFF					
	ON		○	○	○	

Turn Signal Switch (See page 23 - 197 for turn signal circuit diagram)

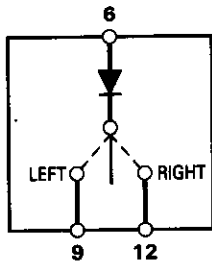

Terminal		6		9	12
RIGHT		○	→		○
Neutral					
LEFT		○	→	○	

Lighting System

Daytime Running Lights Control Unit Input Test (Canada)

CAUTION:

- All SRS electrical wiring harnesses are covered with yellow outer insulation.
- Before disconnecting the SRS wire harness, install the short connector on the airbag (see page 23-294).
- Replace the entire affected SRS harness assembly if it has an open circuit or damaged wiring.

1. Pull the front passenger's carpet away and remove the kick panel.
2. Disconnect the 14-P connector from the daytime running lights control unit.
3. Inspect the connector terminals to be sure they are all making good contact.

- If the terminals are bent, loose, or corroded, repair them as necessary, and recheck the system.
- If the terminals look OK, make the following input tests at the connector.
 - If a test indicates a problem, find and correct the cause, then recheck the system.
 - If all the input tests prove OK, the control unit must be faulty; replace it.

NOTE: Different wires with the same color have been given a number suffix to distinguish them (RED/GRN¹ and RED/GRN² are not the same).

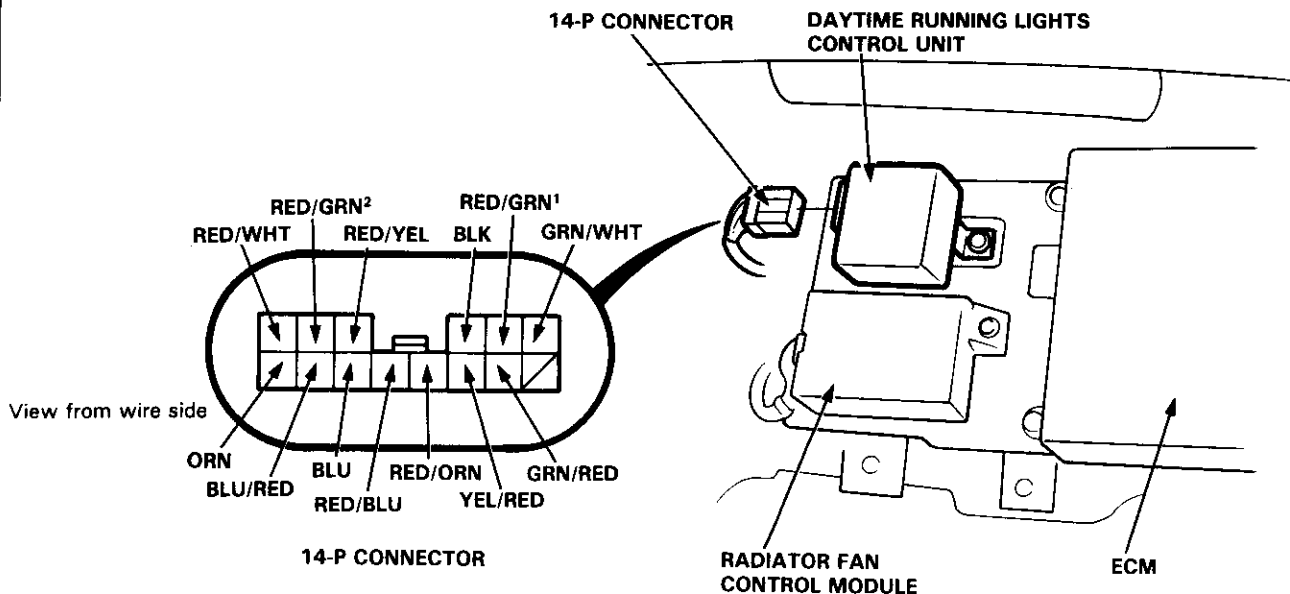
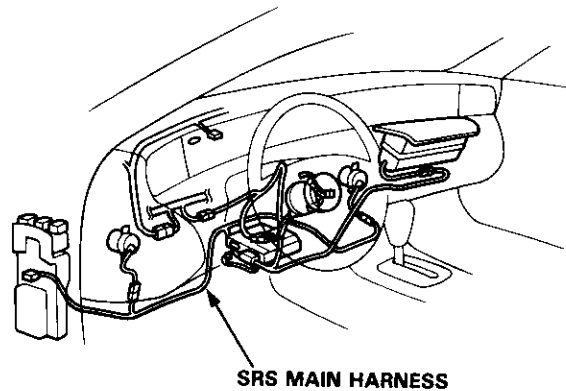



No.	Wire	Test condition	Test: Desired result	Possible cause if result is not obtained
1	BLK	Under all conditions.	Check for continuity to ground: There should be continuity.	<ul style="list-style-type: none"> • Poor ground (G401, G402, G404). • An open in the wire.
2	RED/GRN ²	Under all conditions.	Check for voltage to ground: There should be battery voltage.	<ul style="list-style-type: none"> • Blown No. 37 (40 A) fuse. (In the under-hood fuse/relay box) • Blown No. 8 (10 A) fuse. (In the under-dash fuse/relay box) • An open in the wire.
3	BLU/RED	Under all conditions.	Check for voltage to ground: There should be battery voltage.	<ul style="list-style-type: none"> • Faulty headlight relay. • An open in the wire.
4	YEL/RED	Ignition switch ON.	Check for voltage to ground: There should be battery voltage.	<ul style="list-style-type: none"> • Blown No. 12 (7.5 A) fuse. (In the under-dash fuse/relay box) • An open in the wire.
5	RED/GRN ¹	Passing switch ON.	Check for voltage to ground: There should be battery voltage.	<ul style="list-style-type: none"> • Faulty passing switch. • Faulty dimmer relay. • Faulty headlight relay. • Blown No. 50 (20 A) fuse. (In the under-hood fuse/relay box) • Blown No. 51 (20 A) fuse. • An open in the wire.
6	RED/YEL			
7	RED/BLU	Passing switch ON.	Check for continuity to ground: There should be continuity.	<ul style="list-style-type: none"> • Faulty combination light switch. • Faulty dimmer relay. • An open in the wire.
8	ORN	Combination light switch OFF.		
9	RED/WHT	Combination light switch OFF.	Check for continuity between the terminals: There should be continuity.	<ul style="list-style-type: none"> • Blown headlight bulb (high beam). • An open in the wire.
10	RED/ORN			
11	BLU	Ignition switch ON.	DRL indicator light should come on.	<ul style="list-style-type: none"> • Blown bulb. • An open in the wire.
12	GRN/RED	Ignition switch ON.	Brake system light should come on.	<ul style="list-style-type: none"> • Blown bulb. • An open in the wire.
13	GRN/WHT	Parking brake lever up.	Check for continuity to ground: There should be continuity.	<ul style="list-style-type: none"> • Faulty parking brake switch. • An open in the wire.

Lighting System

Combination Light Switch Replacement

CAUTION:

- All SRS electrical wiring harnesses are covered with yellow outer insulation.
- Before disconnecting the SRS wire harness, install the short connector(s) on the airbag(s) (see page 23-294).
- Replace the entire affected SRS harness assembly if it has an open circuit or damaged wiring.

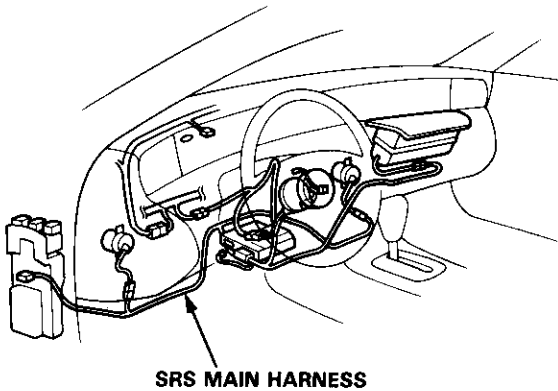

1. Remove the dashboard lower cover and knee bolster.

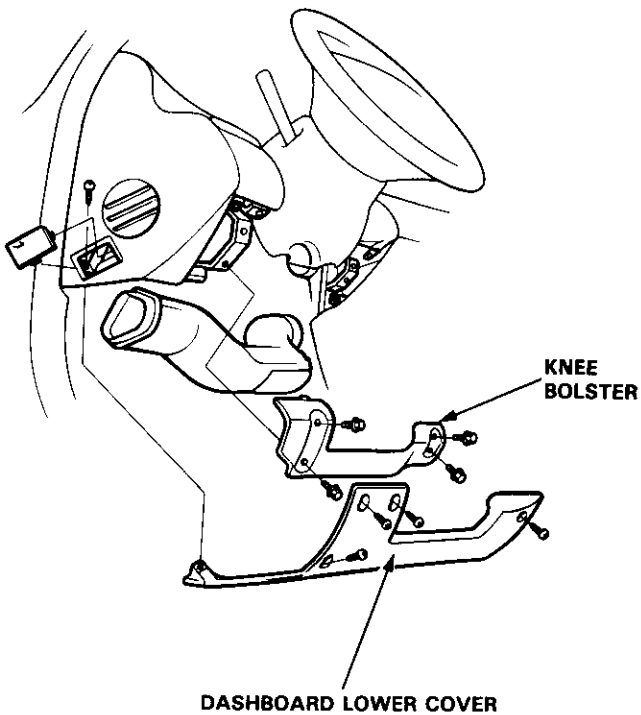

2. Remove the steering column covers.

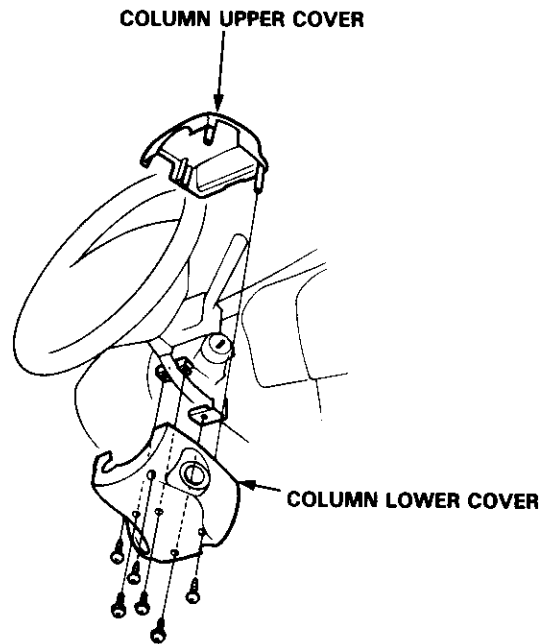

3. Disconnect the connector from the combination light switch assembly, then remove the two screws and the switch.

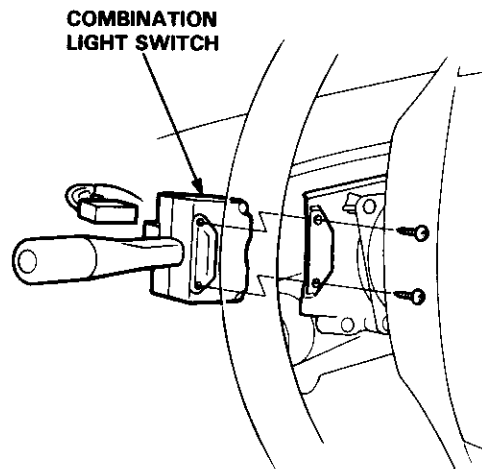

4. Install in the reverse order of removal.

Headlights

Replacement



CAUTION:

- Halogen headlights can become very hot in use; do not touch them or the attaching hardware immediately after they have been turned off.
- Do not try to replace or clean the headlights with the lights on.

1. Remove a screw, then remove the front turn signal light (see page 23-185).
2. Remove a screw, then remove the front side marker light (see page 23-185).
3. Disconnect the connectors from the front turn signal lights and front side marker lights.
4. Remove the front bumper (see section 20).

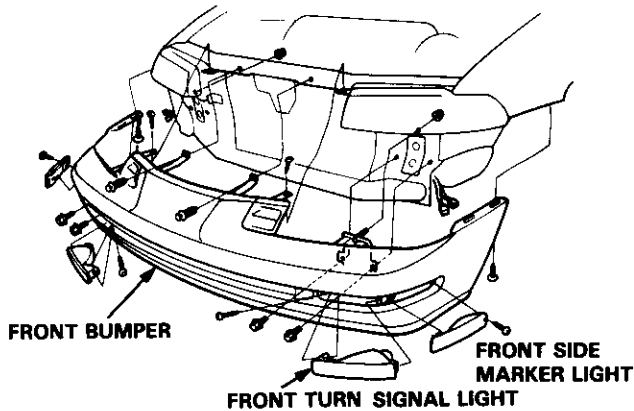

5. Disconnect the 2-P connector from the front parking light, and remove the light by removing the mounting screw.

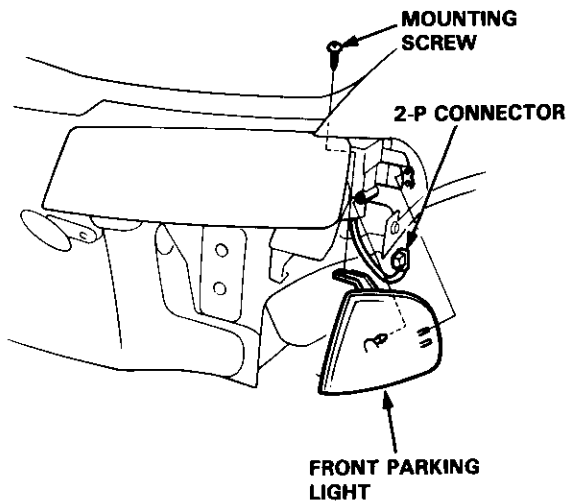

6. Disconnect the 2-P connectors from the headlight bulbs.
7. Remove the mounting bolts and headlight assembly.

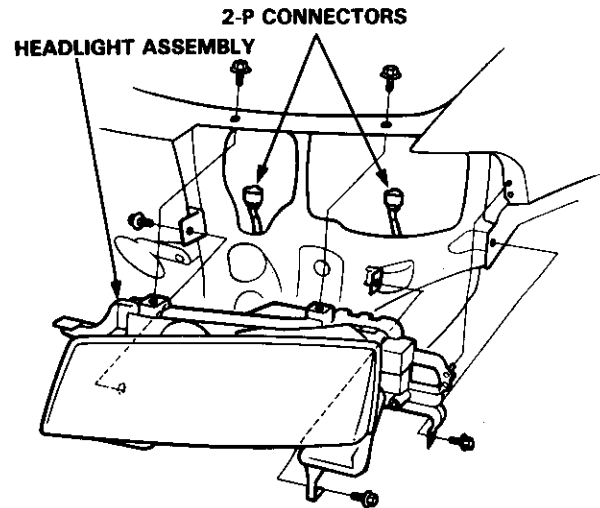

8. After installing the headlights, adjust them to local requirements.

Headlights

Bulb Replacement

CAUTION:

- Halogen headlights can become very hot in use; do not touch them or the attaching hardware immediately after they have been turned off.
- Do not try to replace or clean the headlights with the lights on.

NOTE:

- Before disconnecting the left side connectors, remove the washer reservoir filler neck (one bolt).
- Before disconnecting the right side connectors, remove the battery and the engine coolant reservoir.

1. Disconnect the 2-P connector(s) from the headlight.
2. Turn the bulb holder(s) counterclockwise and remove the bulb(s).

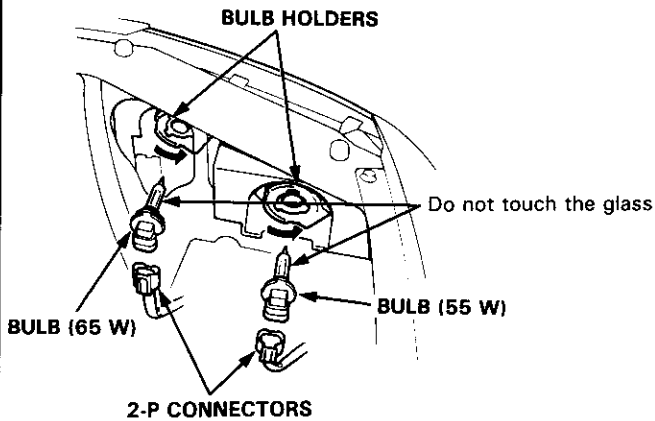

Adjustment

CAUTION:

- Halogen headlights can become very hot in use; do not touch them or the attaching hardware immediately after they have been turned off.
- Do not try to replace or clean the headlights with the lights on.

1. Adjust the headlights to local requirements by turning the adjusters.

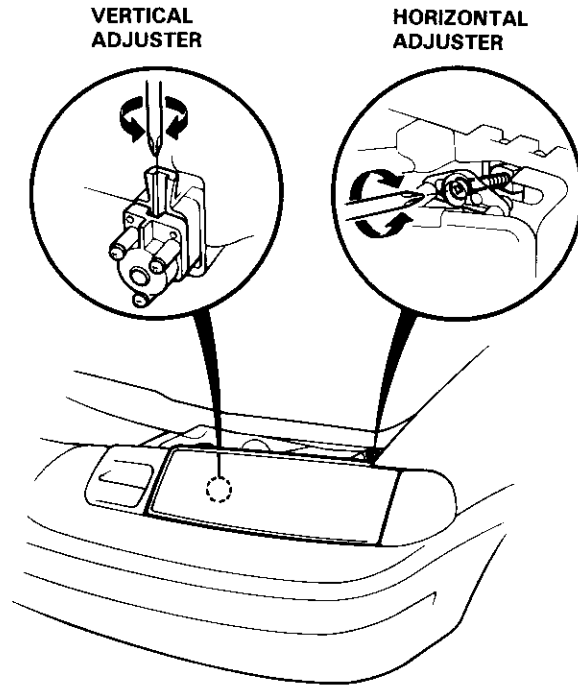

Front Side Marker Lights

Replacement

1. Remove the screw and pull the front side marker light assembly out of the front bumper.

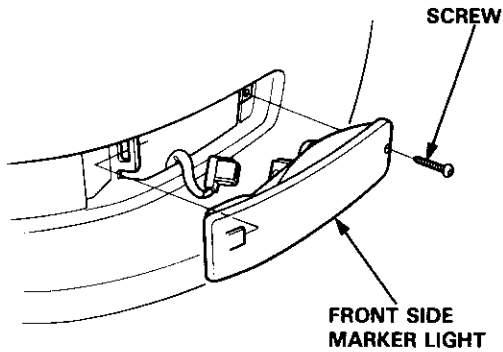

2. Disconnect the 2-P connector from the light.
3. To replace the bulb, turn the bulb socket 45° counterclockwise and remove it from the housing.

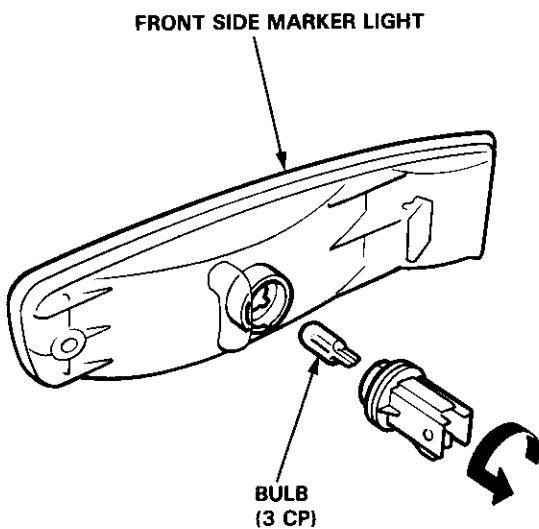

Front Turn Signal Lights



Replacement

1. Remove the screw and pull the front turn signal light assembly out of the front bumper.

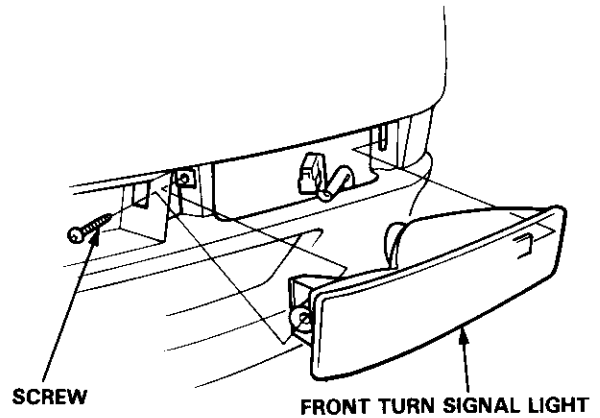

2. Disconnect the 2-P connector from the light.
3. To replace the bulb, turn the bulb socket 45° counterclockwise and remove it from the housing.

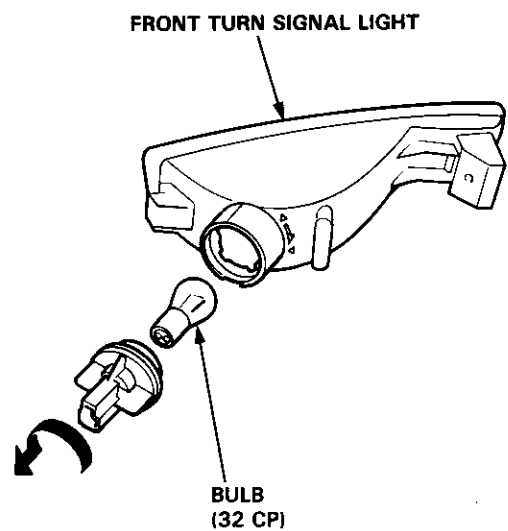

Front Parking Lights

Replacement

1. Remove the screw and separate the parking light from the headlight assembly.

NOTE: Be careful not to damage the headlight and the front fender.

2. Disconnect the 2-P connector from the light.

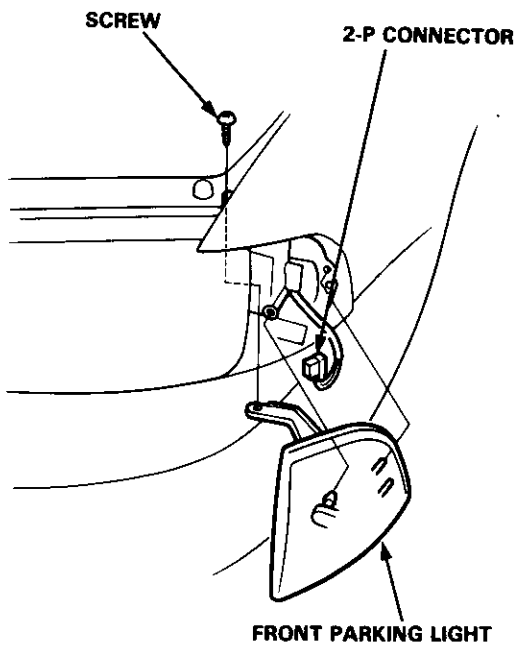

3. Turn the bulb socket 45° counterclockwise and remove it from the housing, then replace the bulb.

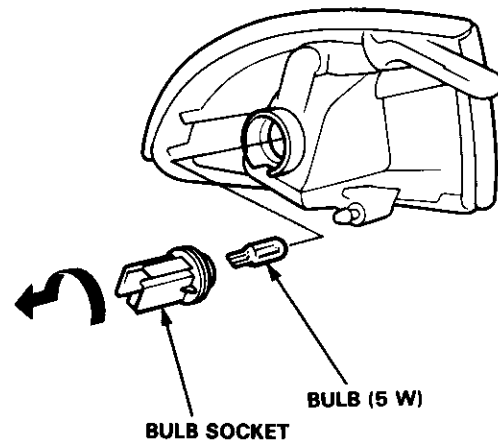



Taillights

Replacement

1. Open the trunk lid and remove the rear trim panel.

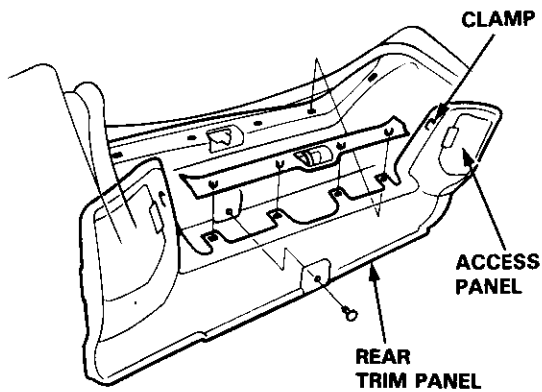

2. Disconnect the 8-P connector from the taillight assembly.
3. Remove the six mounting nuts and the taillight assembly.

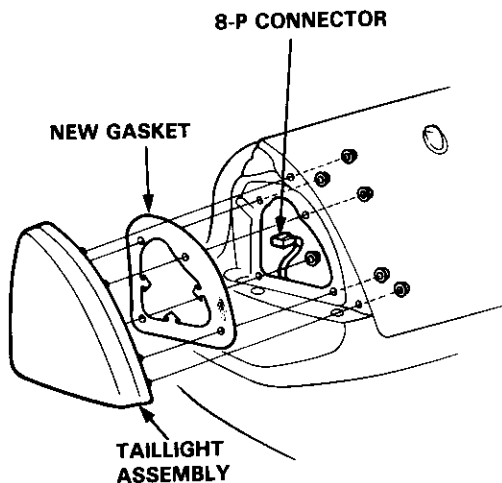

NOTE:

- Inspect the gasket; replace it if it is distorted or stays compressed.
- After installing them, run water over the lights to make sure they do not leak.

Bulb Replacement

1. Open the trunk lid and remove the taillight access panel.
2. Remove the screws and the bulb holder panel.

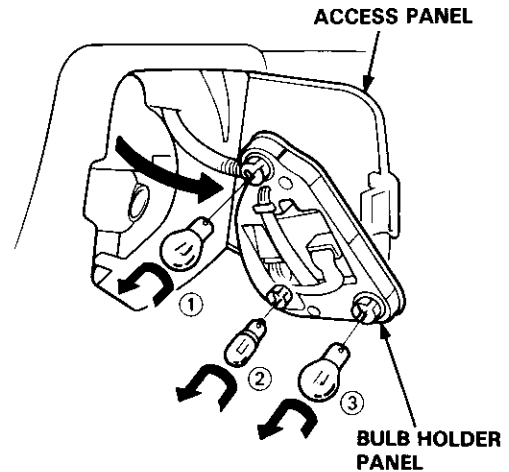

3. Remove the faulty bulb by pushing it in and then turning it 45° counterclockwise.

- ① BRAKE LIGHT/TAILLIGHT BULB (43/3 CP)
- ② TURN SIGNAL LIGHT BULB (45 CP)
- ③ BACK-UP LIGHT BULB (32 CP)

License Plate Lights

Replacement

1. Remove the two screws from the license plate light assembly.
2. Pull the light out and disconnect the 2-P connector from it.

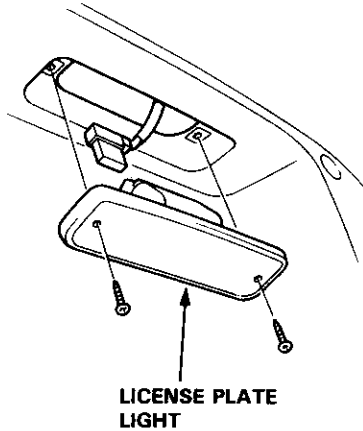

3. Take the lens off, then replace the bulb.

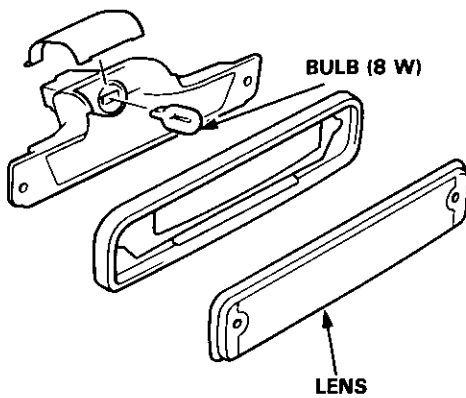

Rear Side Marker Lights

Replacement

1. Remove the screw from the rear side marker light assembly.
2. Carefully pry the light out of the rear bumper and disconnect the 2-P connector from the light.

NOTE: Be careful not to damage the rear bumper.

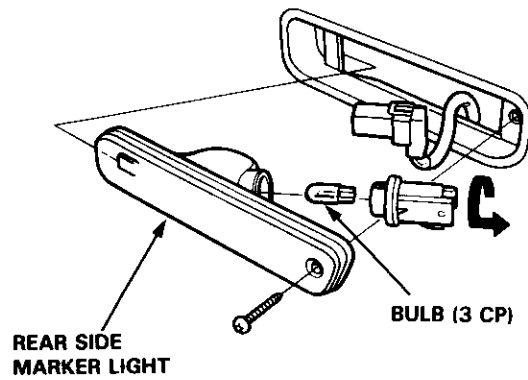

3. Remove the bulb socket by turning it 45° counterclockwise.



Trunk Light and Latch Switch

Trunk Light Test/Replacement

1. Pry off the trunk light lens from the housing.
2. Pry out the light.
3. Disconnect the 2-P connector from the housing.

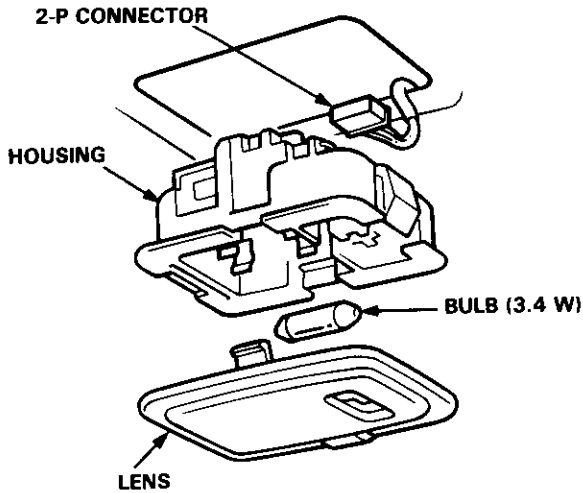

4. Make sure that the bulb is OK. Check for continuity between A (+) and B (-) terminals.

NOTE: This light has a diode in it. To get an accurate reading, either test it with a volt-ohmmeter that compensates for diodes, or make sure you connect your test leads to match the polarity shown.

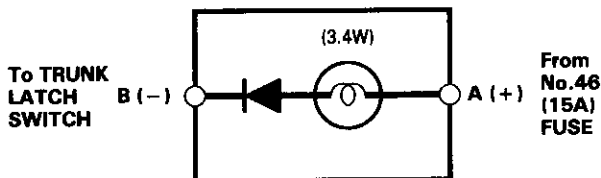
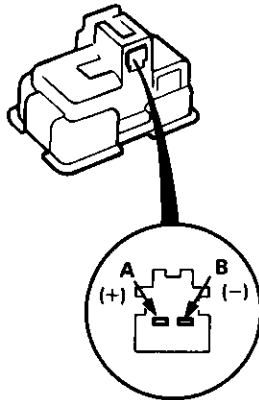

Latch Switch Test/Replacement

1. Open the trunk lid and disconnect the 2-P connector from the trunk latch.
2. Check continuity between terminals A and B. There should be continuity.

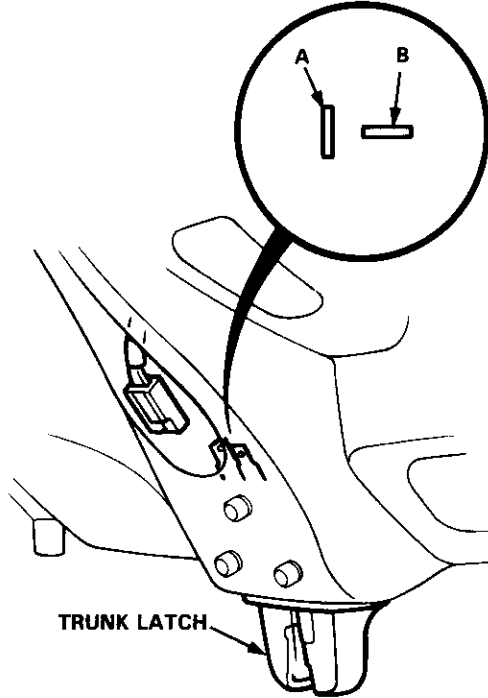

3. If necessary, remove the three bolts and pull the latch out of the trunk lid, then disconnect the lock rod from the latch.
4. Disconnect the trunk opener cable from the latch.

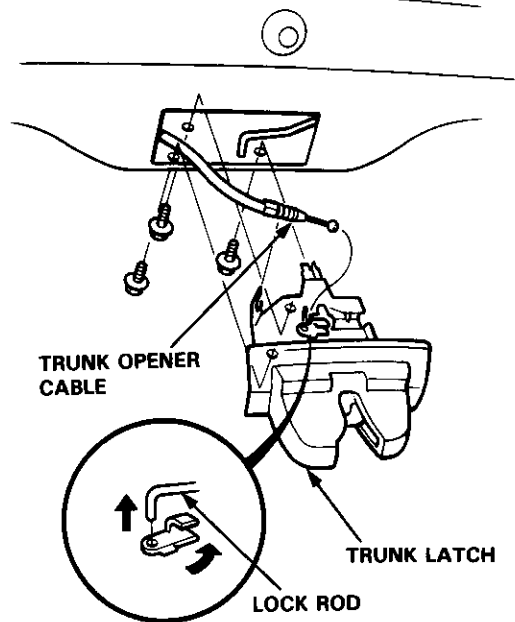

Ceiling Light

Replacement

1. Turn the ceiling light switch OFF.
2. Pry off the lens.

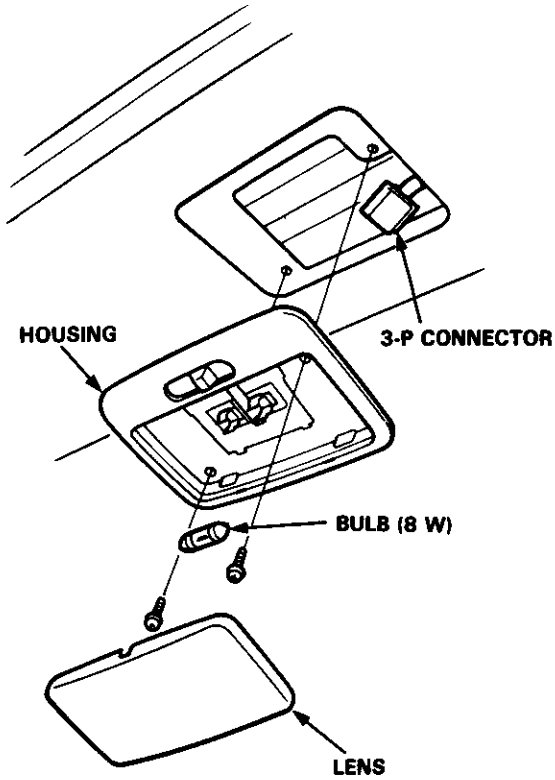

3. Remove the two screws from the ceiling light housing.
4. Disconnect the 3-P connector and remove the housing.

Test

Check for continuity between the terminals in each switch position according to the table.

Terminal Position	A or A'	B or B'	C		D
OFF			○	⊖	○
MIDDLE		○		⊖	○
ON	○			⊖	○

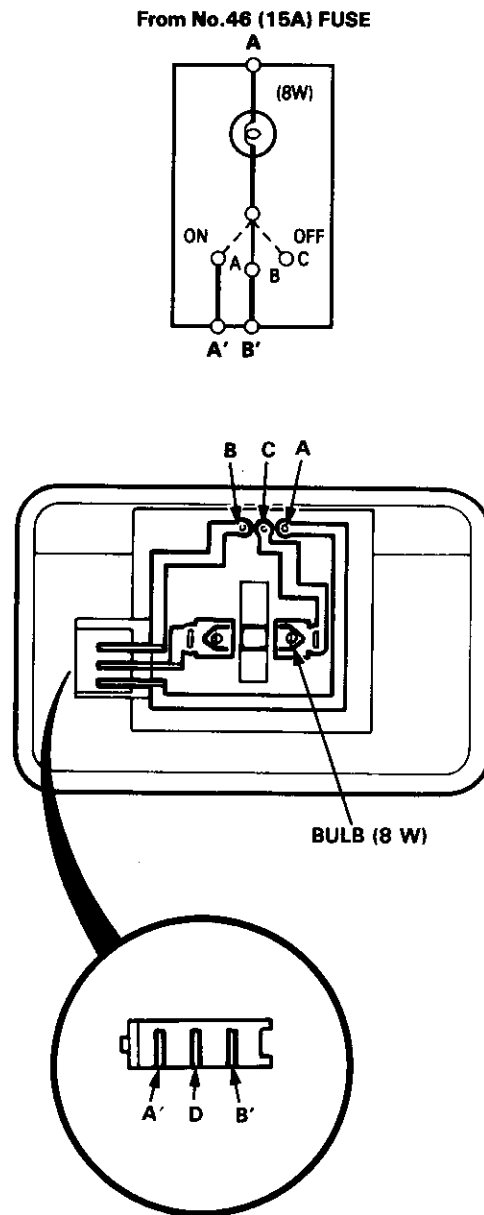



Door Switch Test

1. Remove the screw and pull the door switch out.
2. Disconnect the 1-P connector and remove the switch.
3. Check for continuity between the terminals in each switch position according to the table.

Terminal Position	⊕ TERMINAL	BASE PLATE
CLOSE		
OPEN	○	○

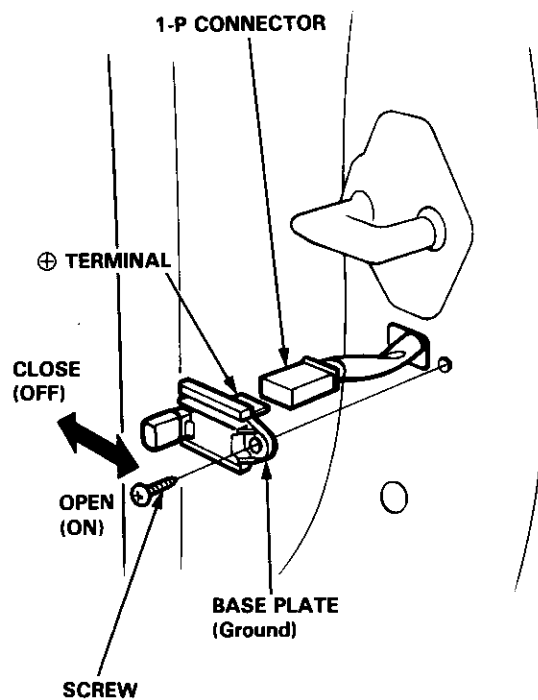

Back – up Lights

Circuit Diagram

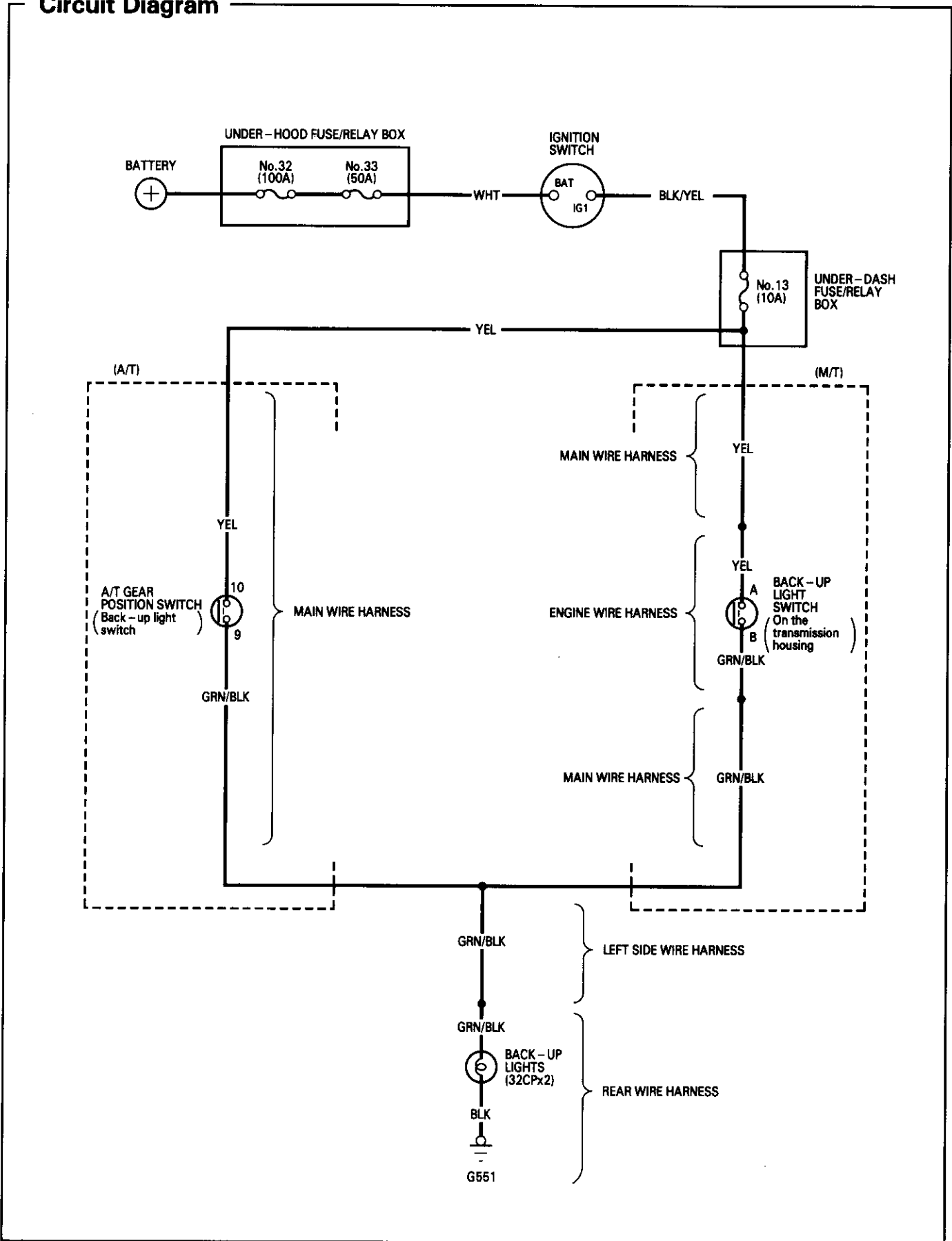

Back-up Lights

Switch Test



Manual Transmission:

1. Turn the ignition switch ON and move the shift lever to **R**. The back-up lights should come on.
 - If a back-up light does not go on, check for:
 - Blown bulb in the taillight assembly.
 - If both back-up lights do not go on, check for:
 - Blown No. 13 (10 A) fuse in the under-dash fuse/relay box.
 - If the fuse and bulbs are OK, go to step 2.
2. Disconnect the connectors from the back-up light switch.

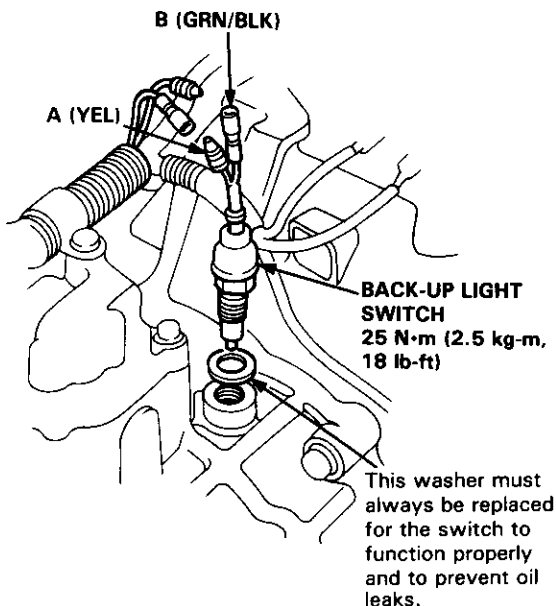

3. Check for continuity between the A and B terminals.
 - There should be continuity only with the shift lever in **R**.
 - If there is no continuity, replace the switch (see section 13).
 - If there is continuity, but the back-up lights do not go on, check for:
 - An open in the YEL or GRN/BLK wire.
 - Poor ground (G551).

Automatic Transmission:

1. Turn the ignition switch on and move the shift lever to **R**. The back-up lights should come on.
 - If a back-up light does not go on, check for:
 - Blown bulb in the taillight assembly.
 - If both back-up lights do not go on, check for:
 - Blown No. 13 (10 A) fuse in the under-dash fuse/relay box.
 - If the fuse and bulbs are OK, go to step 2.
2. Disconnect the 12-P connector from the A/T gear position switch (back-up light switch).

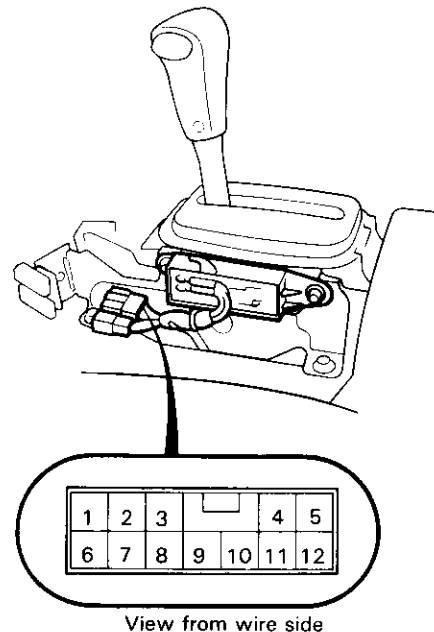

3. Move the shift lever back and forth in **R** without touching the push button, and check for continuity between No. 9 and No. 10 terminals. There should be continuity within the range of free play of the shift lever.
 - If there is no continuity within the range of free play, adjust the position of the A/T gear position switch (see page 23-149).
 - If there is continuity, but the back-up lights do not go on, check for:
 - An open in the YEL or GRN/BLK wire.
 - Poor ground (G551).

Brake Lights and High Mount Brake Light

Circuit Diagram

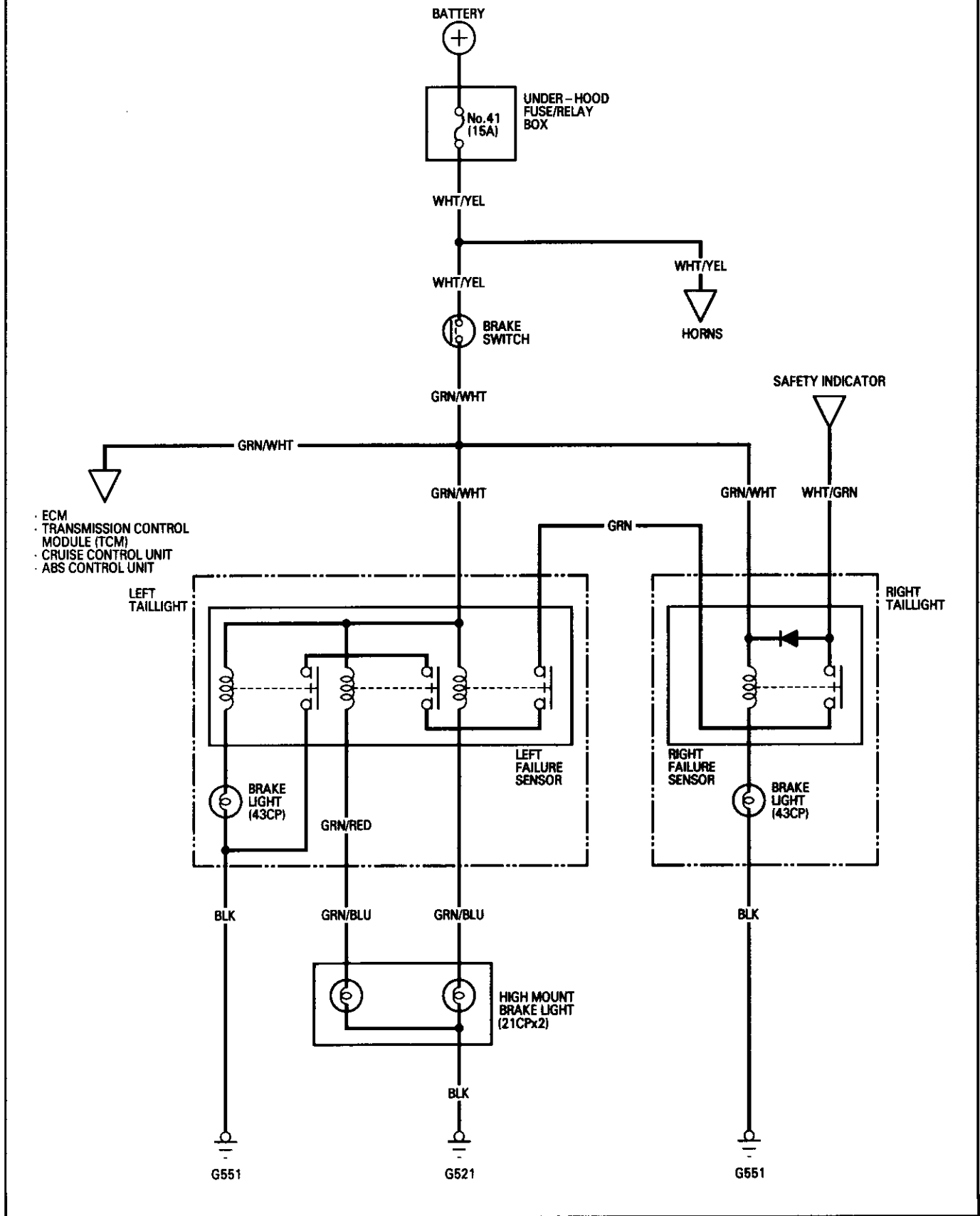



Brake Switch Test

1. If one of the brake lights does not go on, check the bulb in the taillight or the high mount brake light.
2. If none of the brake lights go on, check the No. 41 (15 A) fuse in the under-hood fuse/relay box.
3. If the fuse and bulbs are OK, disconnect the 4-P connector from the brake switch.

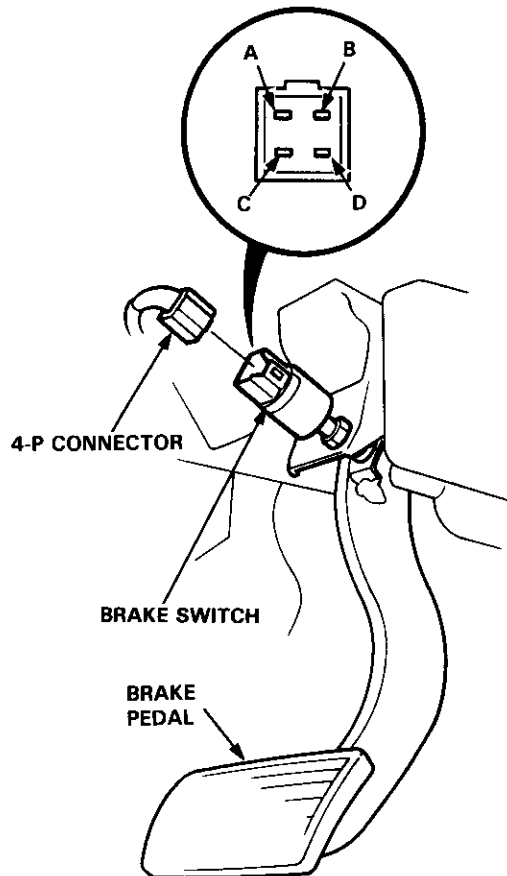

4. Check for continuity between the B and C terminals. There should be continuity with the brake pedal pushed.
 - If there is no continuity, adjust the pedal height (see section 19), and recheck.
 - If there is still no continuity, replace the switch.
 - If there is continuity, but the brake lights do not go on, check for:
 - Poor ground (G551).
 - An open in the WHT/YEL or GRN/WHT wire.
 - Faulty brake light failure sensors (see page 23-157).

High Mount Brake Light/Bulb Replacement

1. Remove the cover.
2. Inspect the bulbs and replace them if they are burned out.

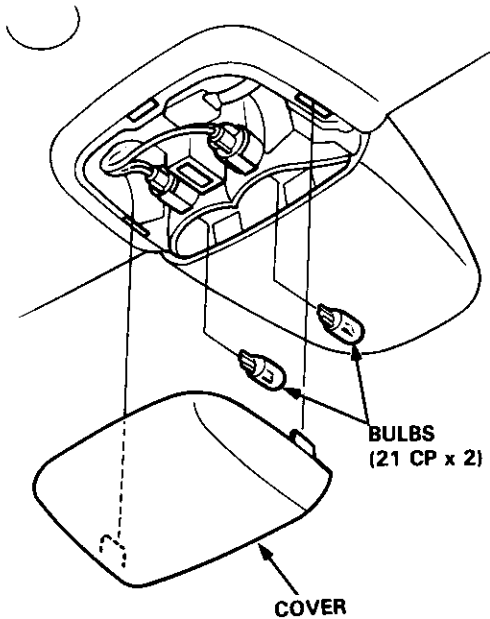

3. If the light is faulty, remove its two mounting bolts.
4. Disconnect the 3-P connector and remove the light.

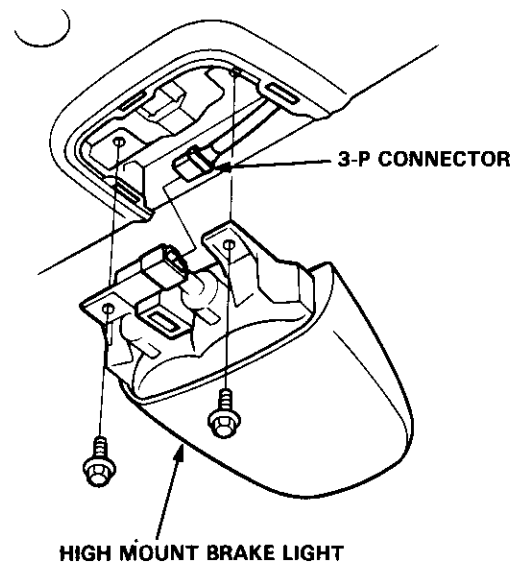

5. Install in the reverse order of removal.

NOTE: Clean the rear window glass first, and make sure the rubber seal on the light is touching the glass all the way around.

Side Marker/Turn Signal/Hazard Flasher System

Component Location Index

CAUTION:

- All SRS electrical wiring harnesses are covered with yellow outer insulation.
- Before disconnecting the SRS wire harness, install the short connector on the airbag(s), then disconnect the wire harness (see page 23-294).
- Replace the entire affected SRS harness assembly if it has an open circuit or damaged wiring.

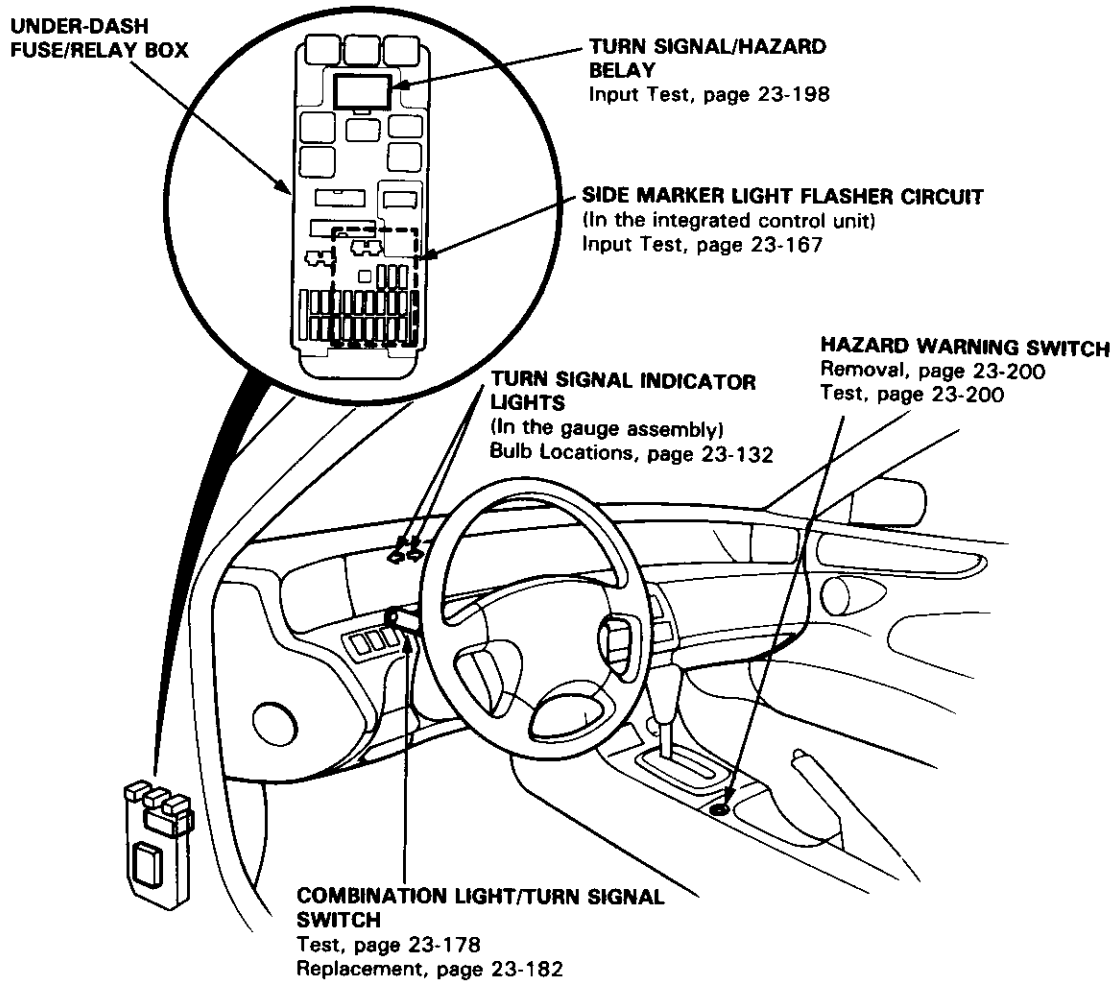
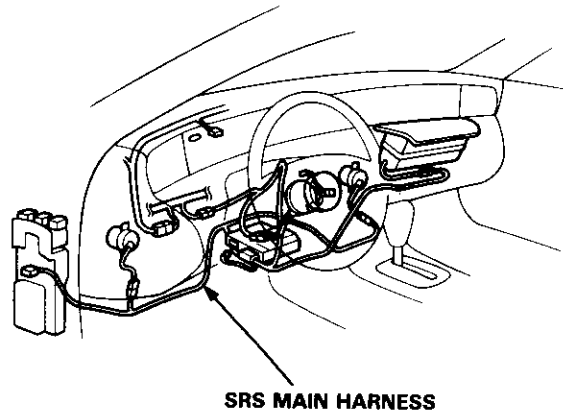



Circuit Diagram

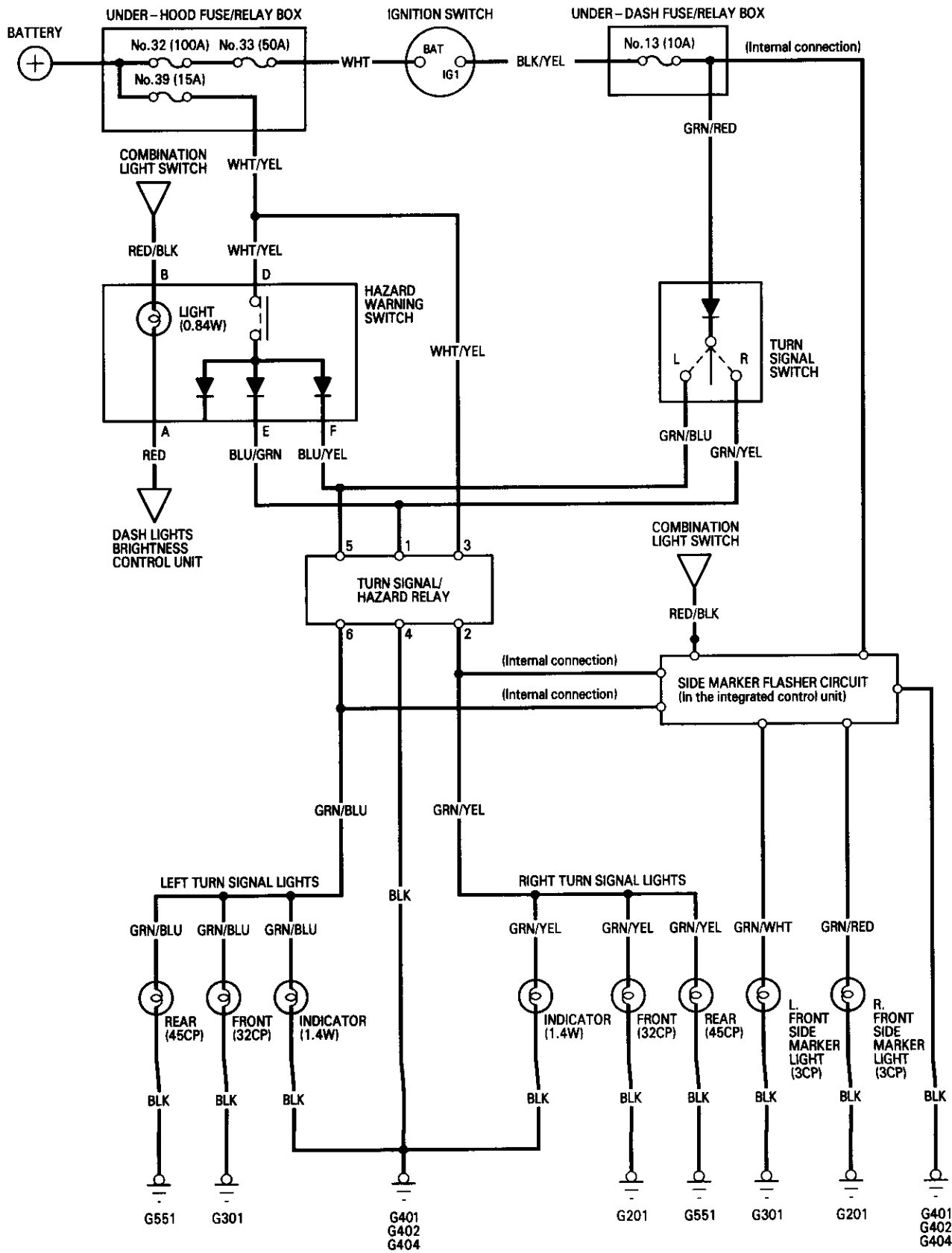

Side Marker/Turn Signal/Hazard Flasher System

Turn Signal/Hazard Relay Input Test

CAUTION:

- All SRS electrical wiring harnesses are covered with yellow outer insulation.
- When disconnecting the SRS wire harness, install the short connector on the airbag(s), then disconnect the wire harness (see page 23-294).
- Replace the entire affected SRS harness assembly if it has an open circuit or damaged wiring.

1. Remove the driver's side kick panel, then remove the turn signal/hazard relay from the under-dash fuse/relay box.
2. Inspect the socket terminals to be sure they are all making good contact.
 - If the terminals are bent, loose, or corroded, repair them as necessary, and recheck the system.
 - If the terminals look OK, make the following input tests at the socket.
 - If a test indicates a problem, find and correct the cause, then recheck the system.
 - If all the input tests prove OK, the turn signal/hazard relay must be faulty; replace it.

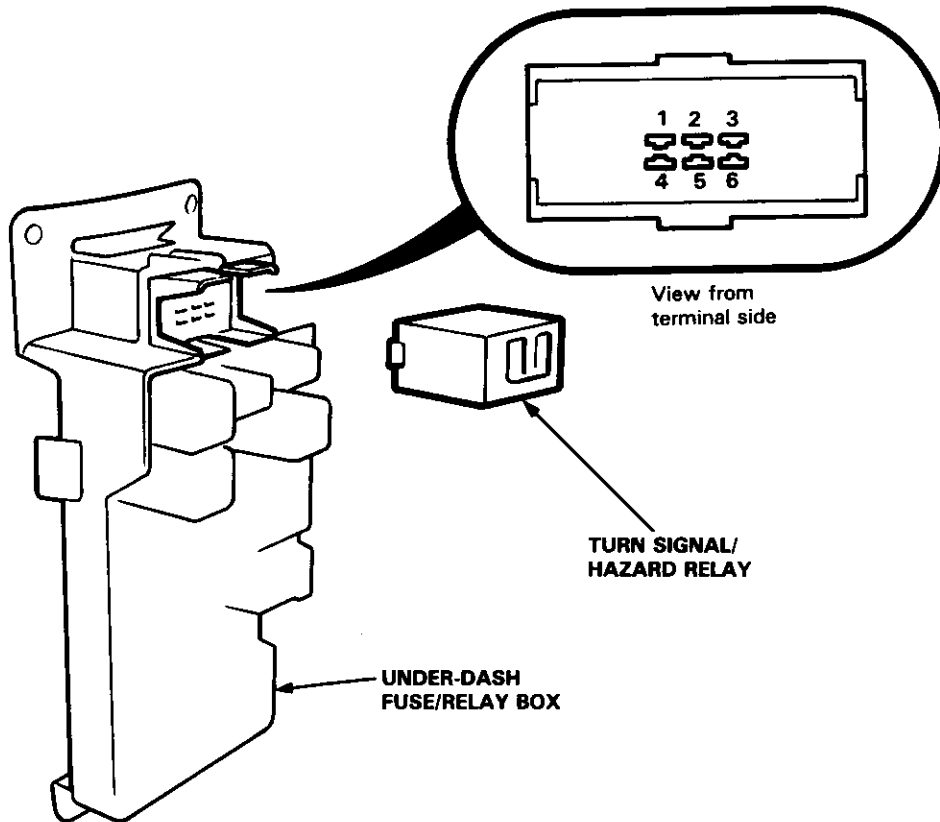
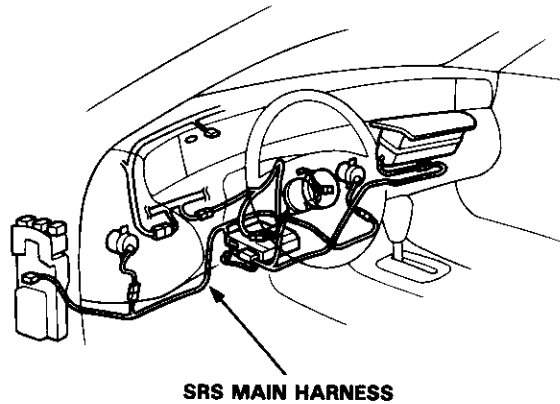



No.	Terminal	Test condition	Test: Desired result	Possible cause if result is not obtained
1	4	Under all conditions.	Check for continuity to ground: There should be continuity.	<ul style="list-style-type: none">• Poor ground (G401, G402, G404).• An open in the wire.
2	3	Under all conditions.	Check for voltage to ground: There should be battery voltage.	<ul style="list-style-type: none">• Blown No. 39 (15 A) fuse. (In the under-hood fuse/relay box)• An open in wire.
3	1	Hazard warning switch ON.	Check for voltage to ground: There should be battery voltage.	<ul style="list-style-type: none">• Faulty hazard warning switch.• An open in the wire.
		Ignition switch ON and turn signal switch in Right position.		<ul style="list-style-type: none">• Blown No. 13 (10 A) fuse. (In the under-dash fuse/relay box)• Faulty turn signal switch.• An open in the wire.
4	5	Hazard warning switch ON.	Check for voltage to ground: There should be battery voltage.	<ul style="list-style-type: none">• Faulty hazard warning switch.• An open in the wire.
		Ignition switch ON and turn signal switch in Left position.		<ul style="list-style-type: none">• Blown No. 13 (10 A) fuse. (In the under-dash fuse/relay box)• Faulty turn signal switch.• An open in the wire.
5	3 • 2	Connect the No. 3 terminal to the No. 2 terminal.	Right turn signal lights should come on when the terminals are connected.	<ul style="list-style-type: none">• Blown bulb.• Poor ground (G201, G551).• An open in the wire.
6	3 • 6	Connect the No. 3 terminal to the No. 6 terminal.	Left turn signal lights should come on when the terminals are connected.	<ul style="list-style-type: none">• Blown bulb.• Poor ground (G301, G551).• An open in the wire.

Side Marker/Turn Signal/Hazard Flasher System

Hazard Warning Switch Replacement

CAUTION: Be careful not to damage the console panels.

1. Remove the front console panel (see section 20).
2. Remove the screw and turn the hazard warning switch slowly in the direction shown and remove it from the center console.
3. Disconnect the 6-P connector from the switch.

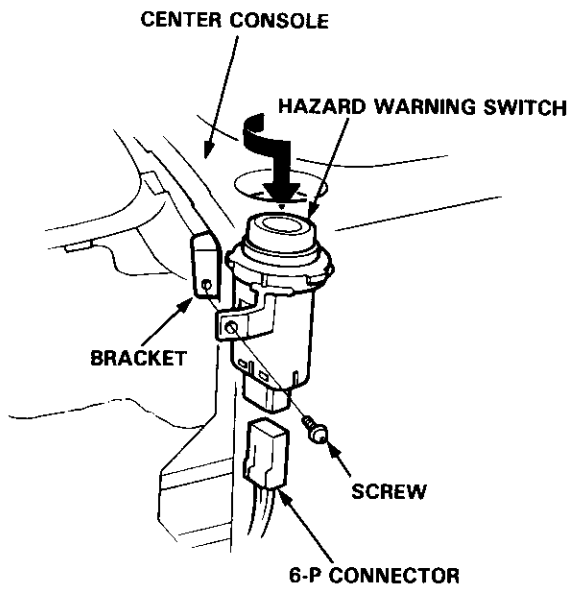

Hazard Warning Switch Test

1. Remove the hazard warning switch from the center console panel.
2. Check for continuity between the terminals in each switch position according to the table.

Terminal	A	B	D	E	F
Position					
ON	○	○	○	○	○
OFF					

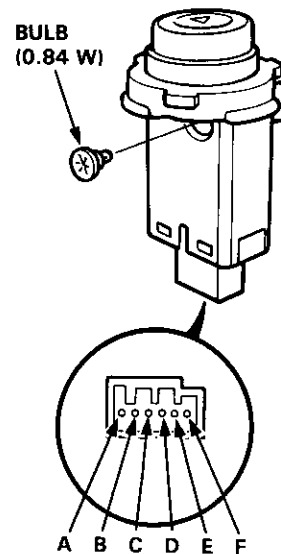
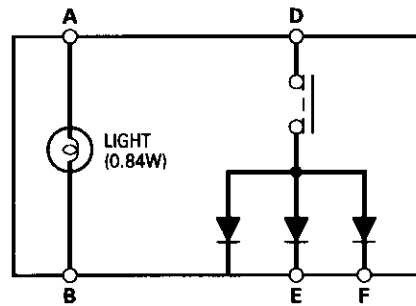



Dash Lights Brightness Control

Component Location Index

CAUTION:

- All SRS electrical wiring harnesses are covered with yellow outer insulation.
- Before disconnecting the SRS wire harness, install the short connector(s) on the airbag(s) (see page 23-294).
- Replace the entire affected SRS harness assembly if it has an open circuit or damaged wiring.
- After installing the gauge assembly, recheck the operation of the SRS indicator light.

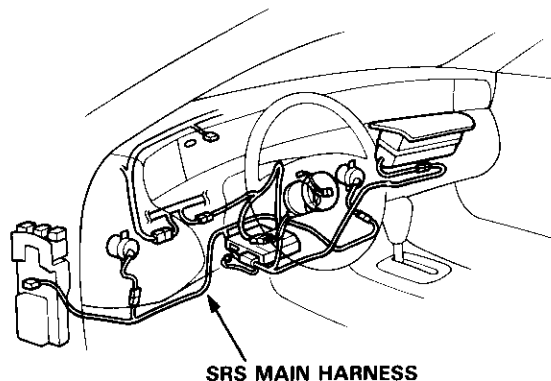

DASH LIGHTS BRIGHTNESS CONTROL UNIT
Test, page 23-204

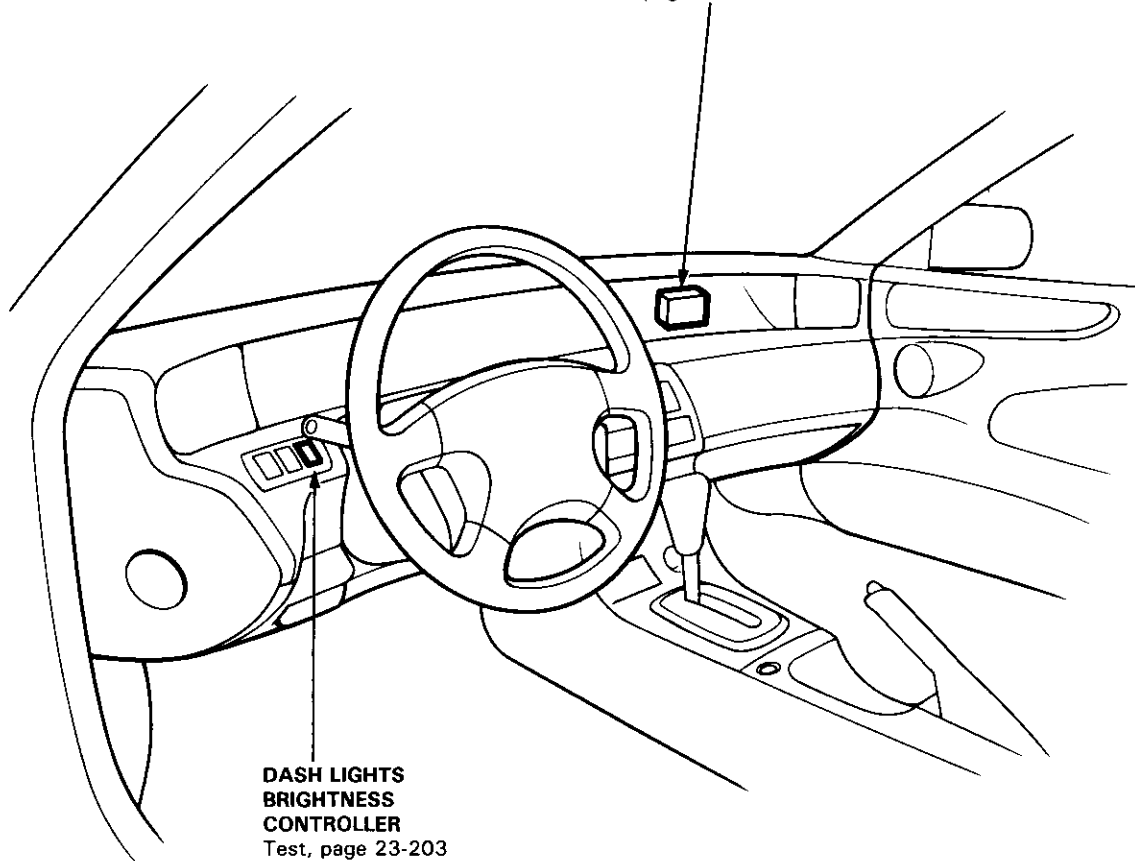

Dash Lights Brightness Control

Circuit Diagram

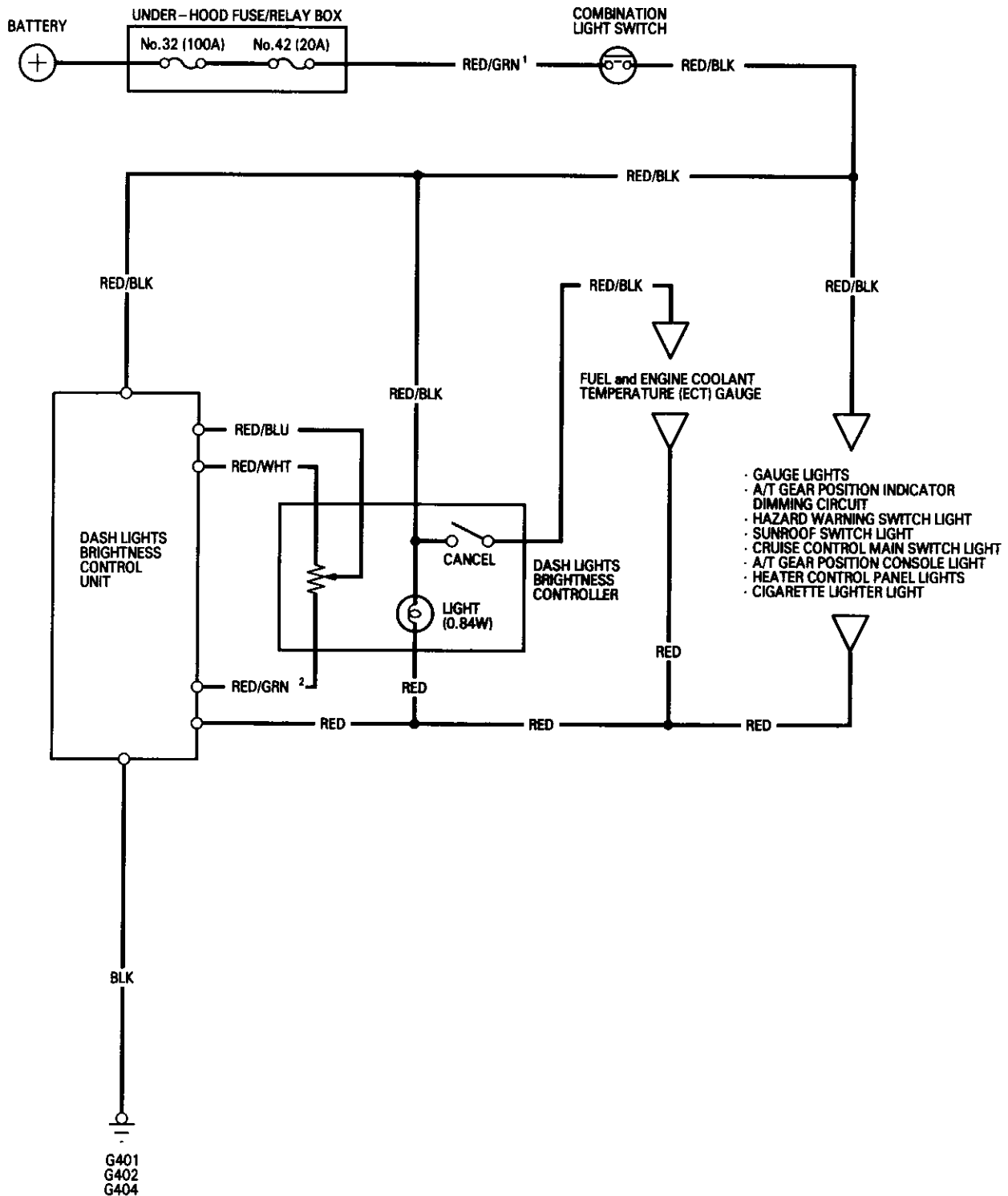



Controller Test

1. Carefully pry the switches out of the dashboard, then disconnect the connectors from them.

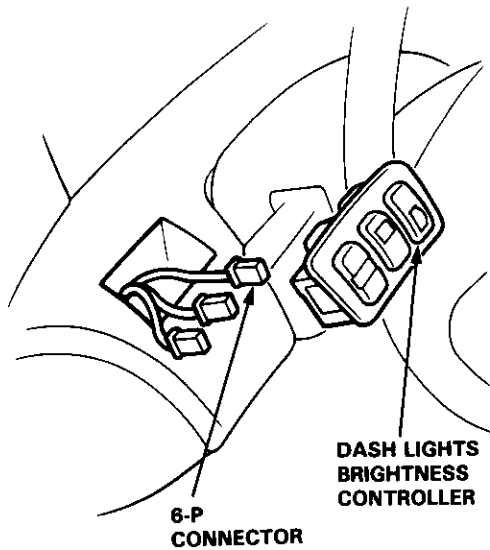

2. Measure resistance between the C and E terminals.

Resistance: 8–12 k Ω

NOTE: Resistance will vary slightly with temperature.

3. Measure resistance between the D and E terminals while rotating the adjusting dial. Resistance should vary from 0 to 10 k Ω as the dial is rotated.
4. Turn the controller off (clicking sound) and check continuity between the B and F terminals. There should be no continuity.
5. If the controller is faulty, remove the two screws and replace it.

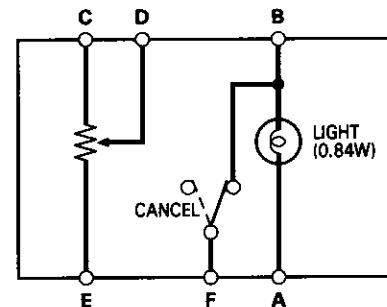
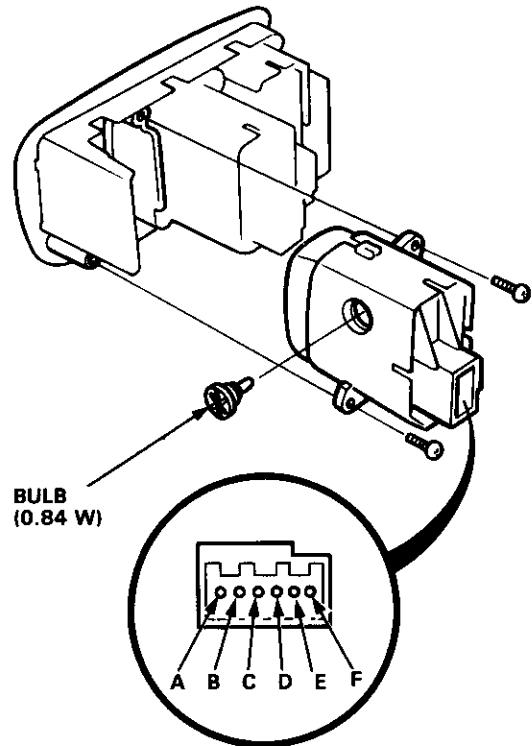

Dash Lights Brightness Control

Control Unit Input Test

CAUTION:

- All SRS electrical wiring harnesses are covered with yellow outer insulation.
- Before disconnecting the SRS wire harness, install the short connector(s) on the airbag(s) (see page 23-294).
- Replace the entire affected SRS harness assembly if it has an open circuit or damaged wiring.
- After installing the gauge assembly, recheck the operation of the SRS indicator light.

1. Remove the sub gauge assembly (see page 23-131).
2. Disconnect the 6-P connector from the control unit.
3. Inspect the connector terminals to be sure they are all making good contact.
 - If the terminals are bent, loose, or corroded, repair them as necessary, and recheck the system.
 - If the terminals look OK, make the following input tests at the connector.
 - If a test indicates a problem, find and correct the cause, then recheck the system.
 - If all input tests prove OK, the control unit must be faulty; replace it.

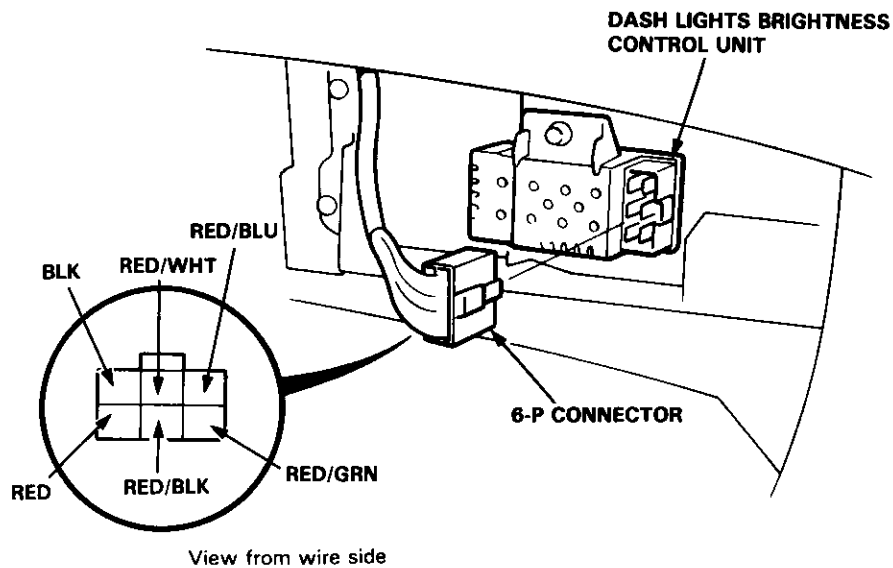
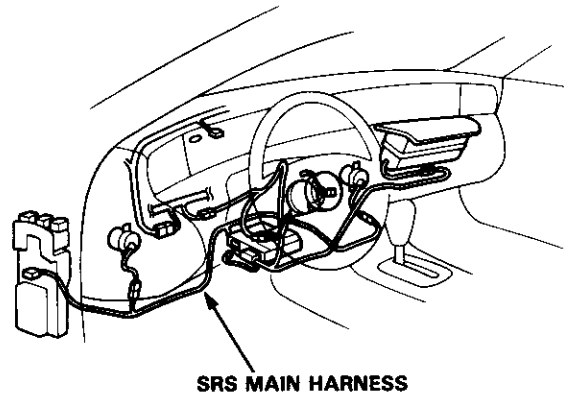



No.	Wire	Test condition	Test: Desired result	Possible cause if result is not obtained
1	BLK	Under all conditions.	Check for continuity to ground: There should be continuity.	<ul style="list-style-type: none">• Poor ground (G401, G402, G404).• An open in the wire.
2	RED/BLK	Combination light switch ON.	Check for voltage to ground: There should be battery voltage.	<ul style="list-style-type: none">• Blown No. 42 (20 A) fuse. (In the under-hood fuse/relay box)• Faulty combination light switch.• An open in the wire.
3	RED	Combination light switch ON.	Attach to ground: Dash lights should come on full bright.	<ul style="list-style-type: none">• An open in the wire.
4	RED/GRN or RED/WHT	Adjusting dial rotating.	Check for resistance between the RED/GRN and RED/WHT terminals: There should be 8–12 k Ω at all times.	<ul style="list-style-type: none">• Faulty controller.• An open in the wires.
5	RED/BLU and RED/WHT	Adjusting dial rotating.	Check for resistance between the RED/BLU and RED/WHT terminals: It should vary from 0–10 k Ω as the dial is rotated.	

Stereo Sound System

Component Location Index

CAUTION:

- All SRS electrical wiring harnesses are covered with yellow outer insulation.
- Before disconnecting the SRS wire harness, install the short connector(s) on the airbag(s) (see page 23-294).
- Replace the entire affected SRS harness assembly if it has an open circuit or damaged wiring.

NOTE: The radio may have a coded theft protection circuit. Be sure to get the customer's code number before

- Disconnecting the battery.
- Removing the No. 43 (10 A) fuse.
(In the under-hood fuse/relay box)
- Removing the radio.

After service, reconnect power to the radio and turn it on. When the word "CODE" is displayed, enter the customer's 5-digit code to restore radio operation.

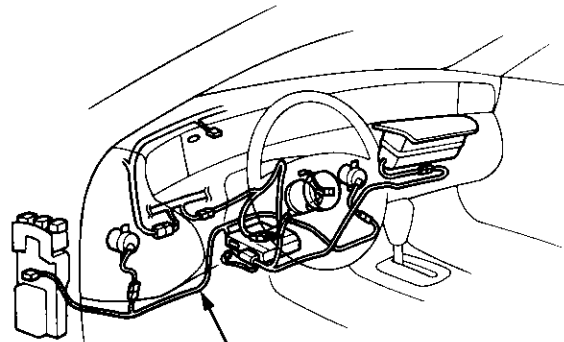

SRS MAIN HARNESS

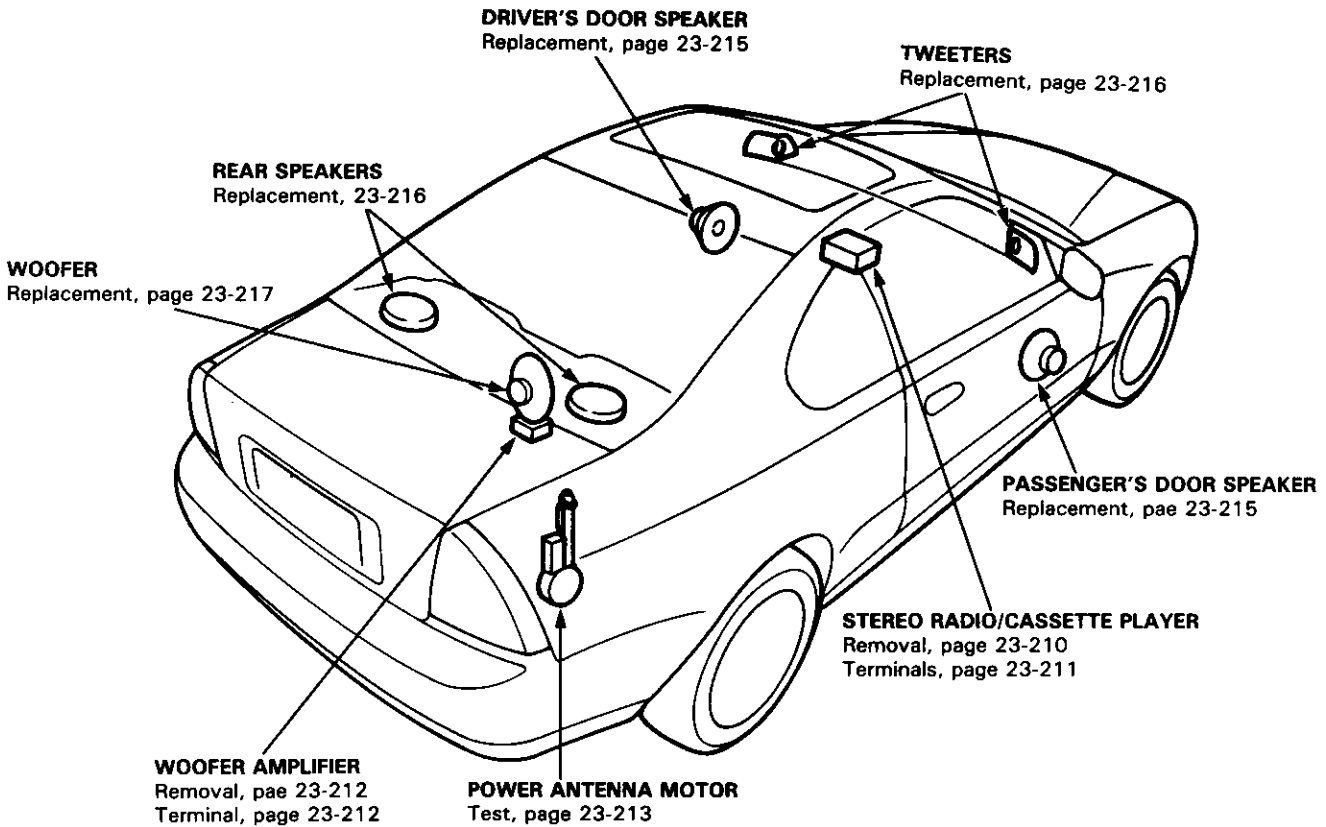



Description:

For the description of a factory-installed stereo radio/cassette player, please see the owner's manual.

The power antenna is controlled by the radio ON/OFF switch. It will extend fully whenever the radio switch and the ignition switch are on at the same time. When the radio or the ignition is shut off, the antenna retracts fully. The antenna motor has a built-in relay together with a limit switch for this function.

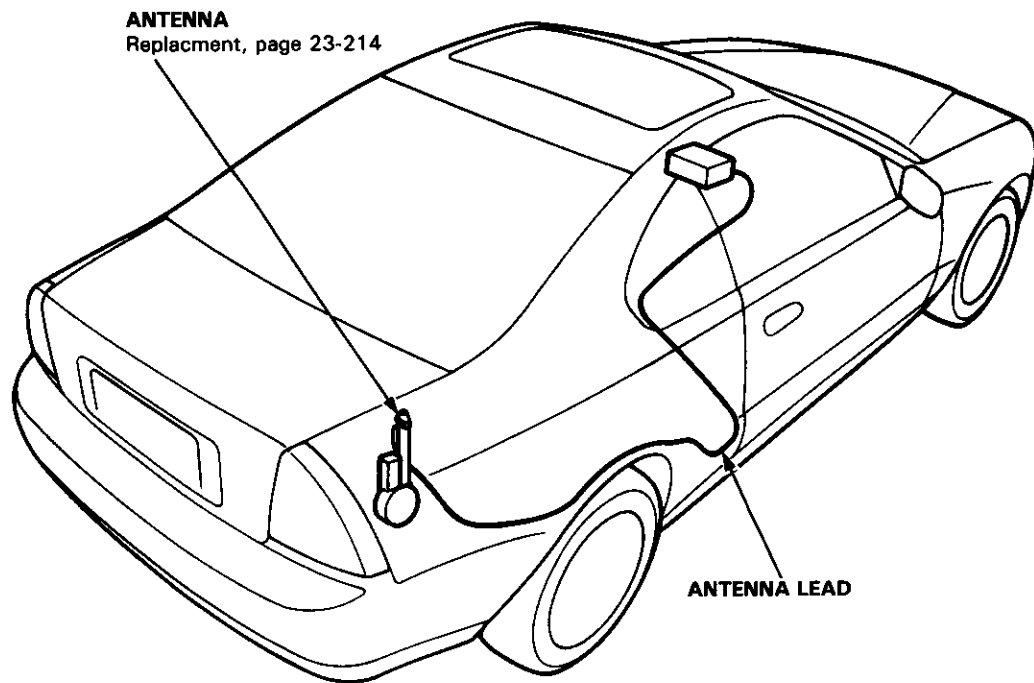

Stereo Sound System

Circuit Diagram (Except Seven Speakers System)

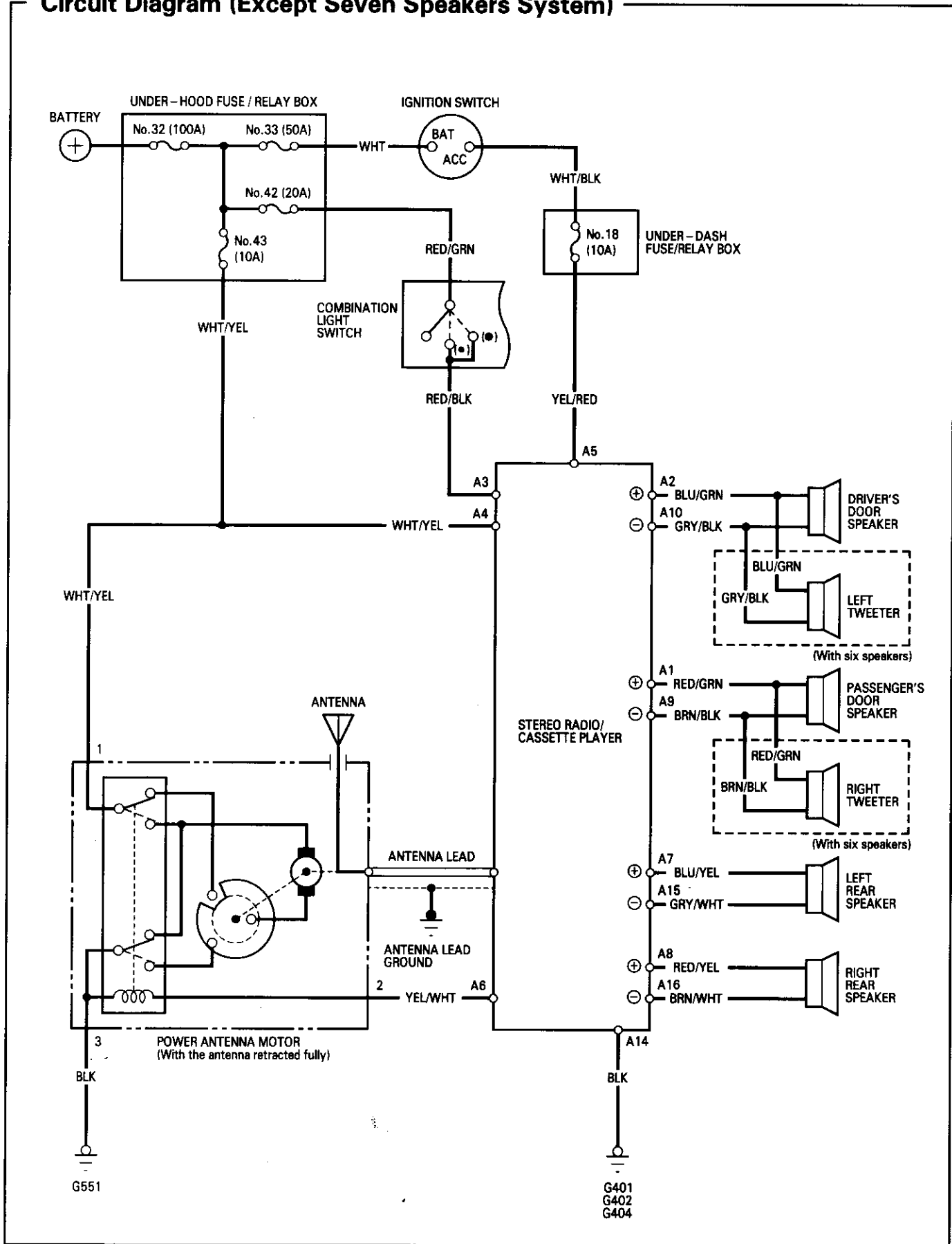



Circuit Diagram (With Seven Speakers System)

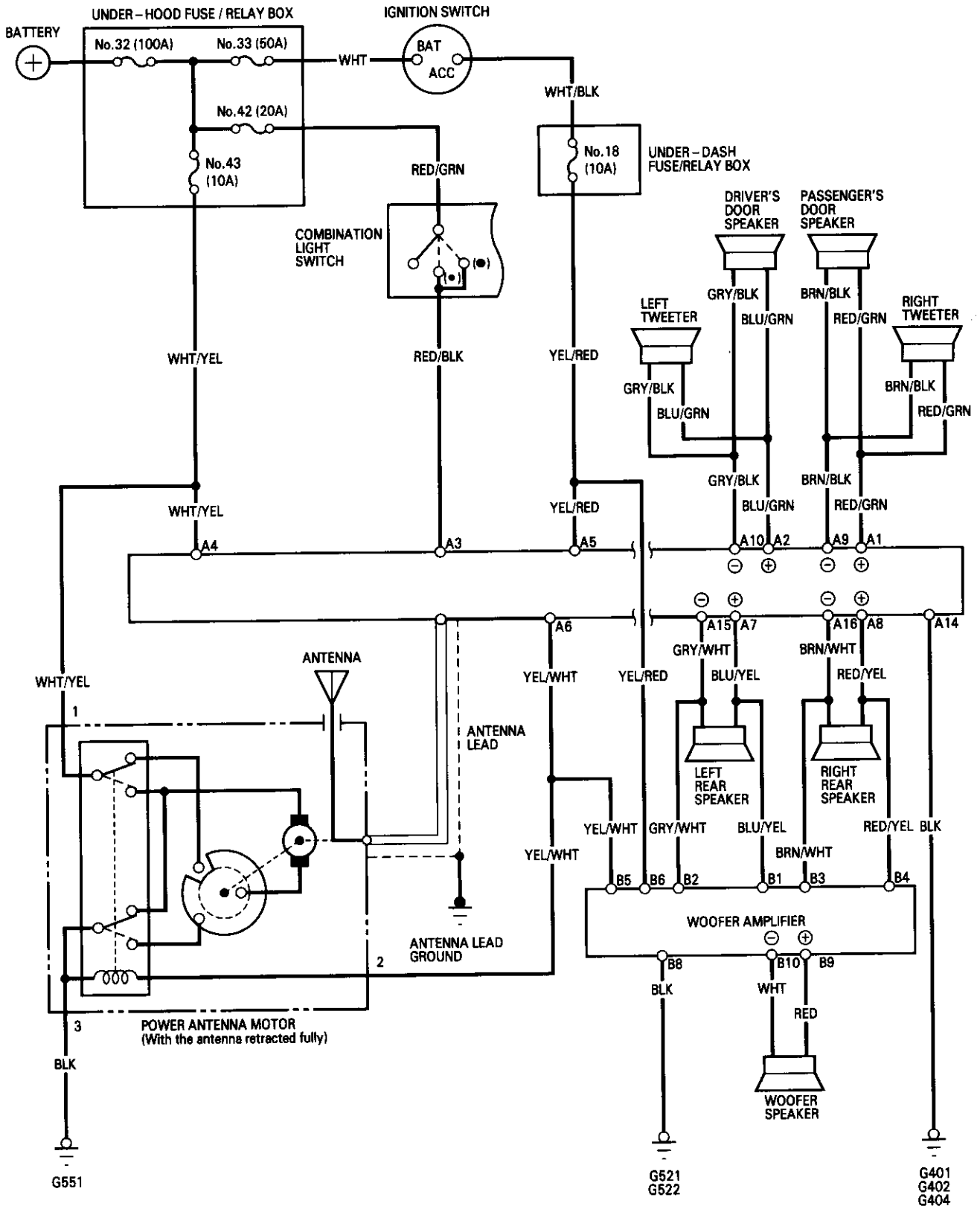

Stereo Sound System

Unit Removal

CAUTION:

- All SRS electrical wiring harnesses are covered with yellow outer insulation.
- Before disconnecting the SRS wire harness, install the short connector(s) on the airbag(s) (see page 23-294).
- Replace the entire affected SRS harness assembly if it has an open circuit or damaged wiring.

NOTE: The radio may have a coded theft protection circuit. Be sure to get the customer's code number before.

- Disconnecting the battery.
- Removing the No. 43 (10 A) fuse.
(In the under-hood fuse/relay box)
- Removing the radio.

After service, reconnect power to the radio and turn it on. When the word "CODE" is displayed, enter the customer's 5-digit code to restore radio operation.

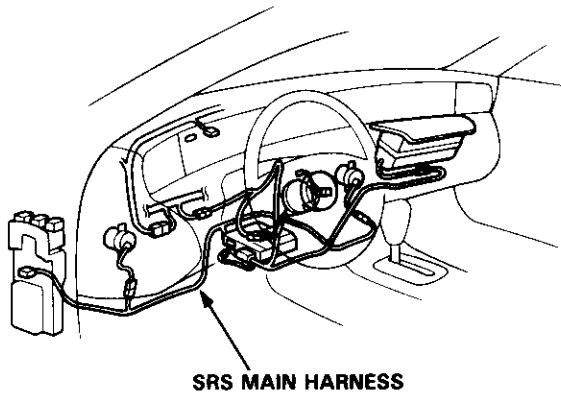

1. Remove the 10 mounting screws, then remove the front console.

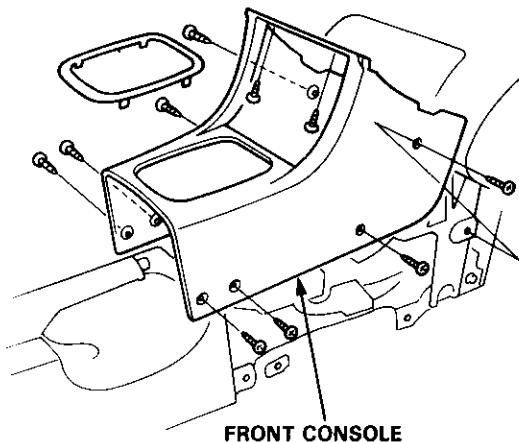

2. Remove the four mounting screws and pull the radio panel assembly out part of the way.

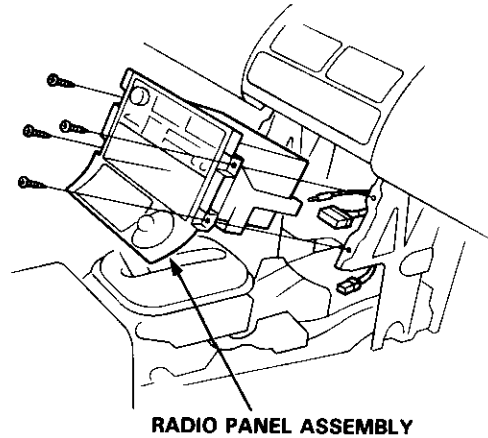

3. Disconnect the connectors and antenna lead, then remove the assembly.
4. Remove the two mounting screws, then remove the stereo radio/cassette player from the panel assembly.

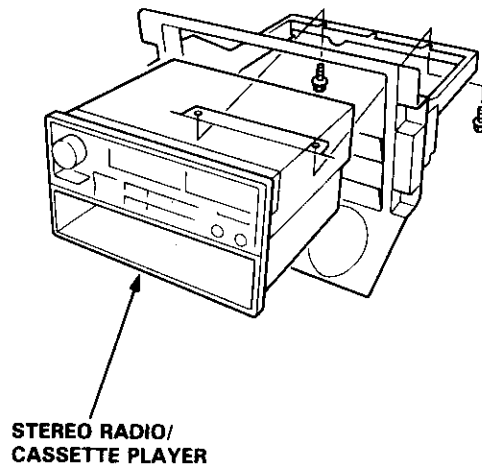



Stereo Radio/Cassette Player Terminals

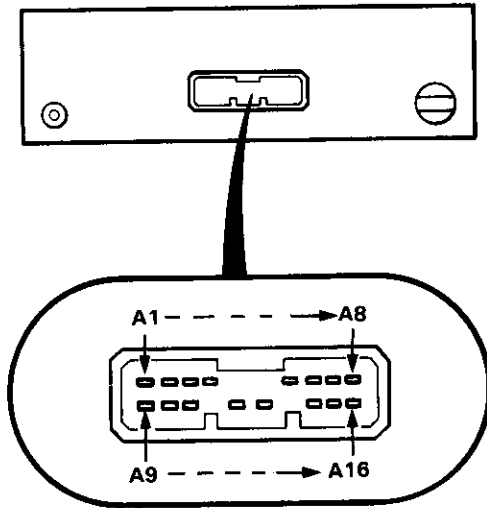

Terminal	Wire	Connects to
A1	RED/GRN	Right front speaker ⊕
A2	BLU/GRN	Left front speaker ⊕
A3	RED/BLK	Lights-on signal
A4	WHT/YEL	Constant power (Tuning memory)
A5	YEL/RED	ACC
A6	YEL/WHT	Radio switched power
A7	BLU/YEL	Left rear speaker ⊕
A8	RED/YEL	Right rear speaker ⊕
A9	BRN/BLK	Right front speaker ⊖
A10	GRY/BLK	Left front speaker ⊖
A11	—	(Not used)
A12	—	(Not used)
A13	—	(Not used)
A14	BLK	Ground (G401, G402, G404)
A15	GRY/WHT	Left rear speaker ⊖
A16	BRN/WHT	Right rear speaker ⊖

Stereo Sound System

Woofer Amplifier Removal

1. Remove the rear seat (see section 20).
2. Remove the rear seat center pad (see section 20).
3. Remove the three screws and disconnect the 10-P connector from the amplifier, then remove it.

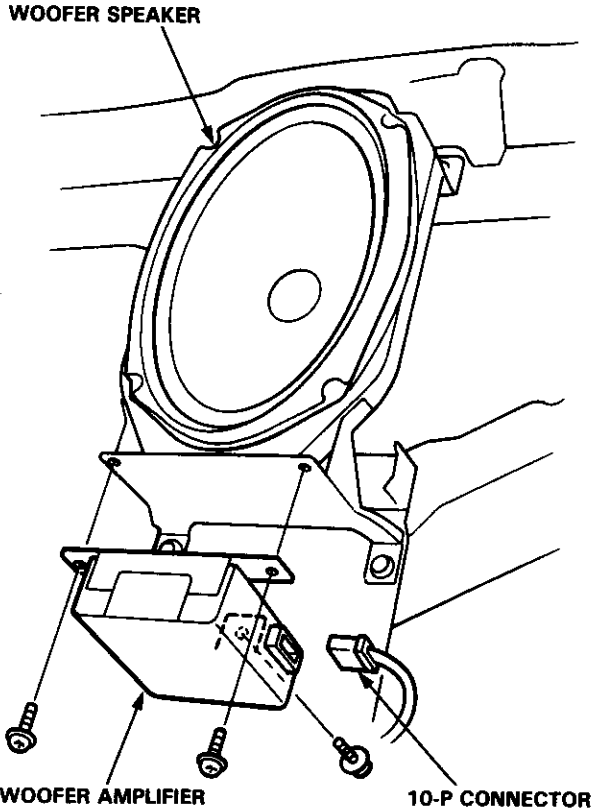

Woofer Amplifier Terminals

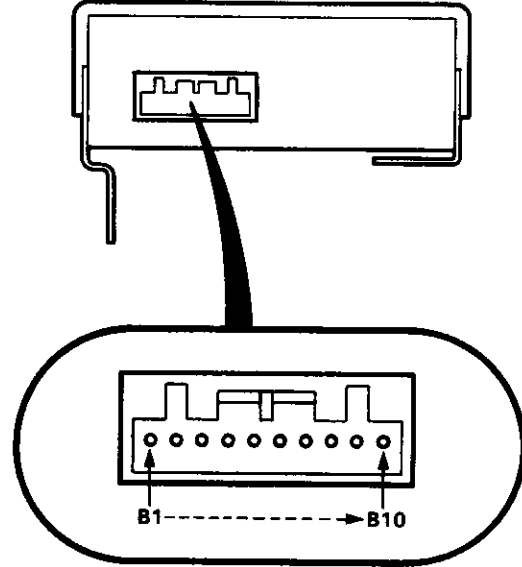

Terminal	Wire	Connects to
B1	BLU/YEL	Left rear speaker ⊕
B2	GRY/WHT	Left rear speaker ⊖
B3	BRN/WHT	Right rear speaker ⊖
B4	RED/YEL	Right rear speaker ⊕
B5	YEL/WHT	Radio switched power
B6	YEL/RED	ACC
B7	—	(Not used)
B8	BLK	Ground (G522)
B9	RED	Woofer speaker ⊕
B10	WHT	Woofer speaker ⊖



Power Antenna Motor Test

1. Remove the trunk right side trim panel.
2. Disconnect the 3-P connector from the motor, and remove the connector from its clamp.
3. First, check power to the motor at the connector terminals:

- There should be battery voltage between the WHT/YEL (+) and BLK (-) terminals all the time.
- There should be battery voltage between the YEL/WHT (+) and BLK (-) terminals only with the ignition and radio switched ON.

View from wire side

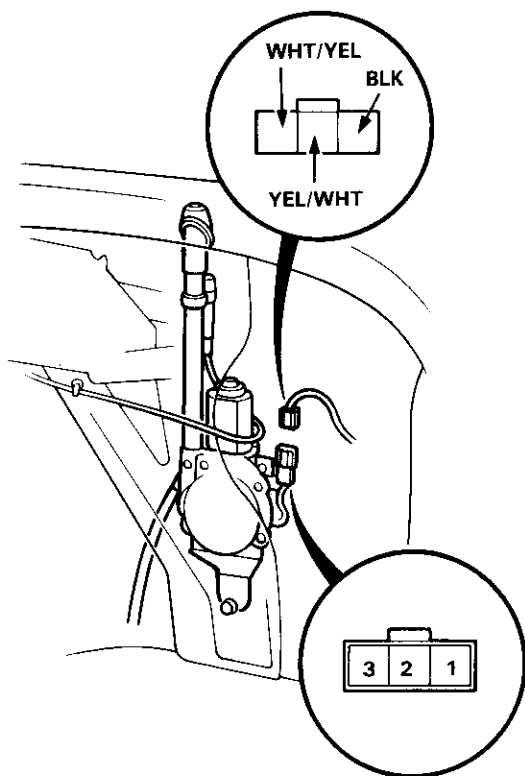

View from wire side

4. Test motor operation:

EXTEND: Connect battery power to the No. 1 and No. 2 terminals and ground to the No. 3 terminal.

RETRACT: Then disconnect power from the No. 2 terminal.

5. If the motor fails to operate properly, replace it.

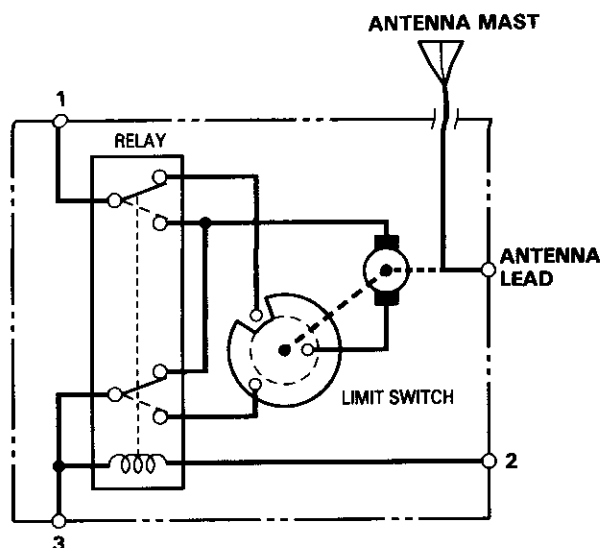

Sticking Antenna:

The antenna sticks in either the up or down position.

1. Using the antenna nut wrench, remove the special nut, spacer, and bushing (see next page).
2. Clean the antenna mast housing threads, then reinstall the spacer and bushing.

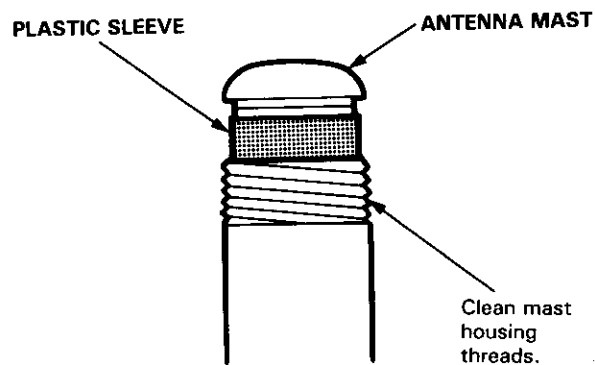

3. Use the antenna nut wrench and torque the special nut to 2.3 N·m (0.23 kg·m, 1.7 lb·ft). If the special nut is over-torqued, the antenna may stick. If sticking occurs, back the nut off until the antenna moves freely.

Stereo Sound System

Antenna Mast Replacement

NOTE: The antenna mast alone can be replaced without having to remove the power antenna motor.

1. Remove the special nut, spacer, and bushing.
2. Carefully withdraw the antenna mast while extending it by turning the radio switch ON.

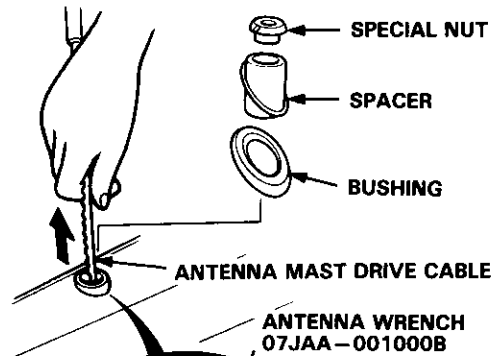

SPECIAL NUT
2.3 N·m (0.23 kg-m, 1.7 lb-ft)

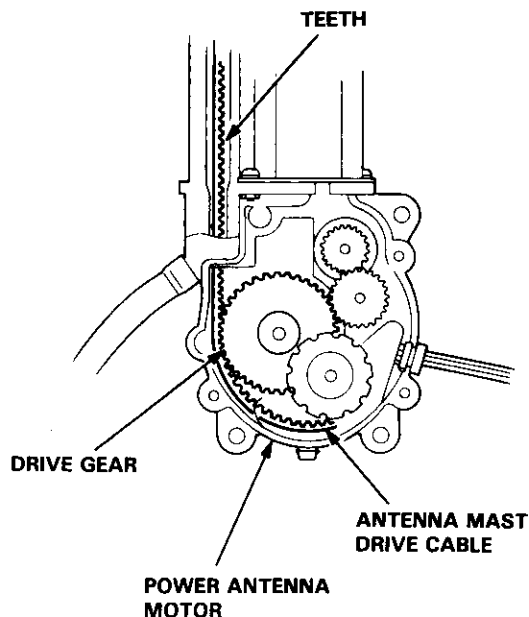

3. Hold the new antenna so the teeth on the drive cable face in the direction shown, and insert the drive cable into the antenna housing.

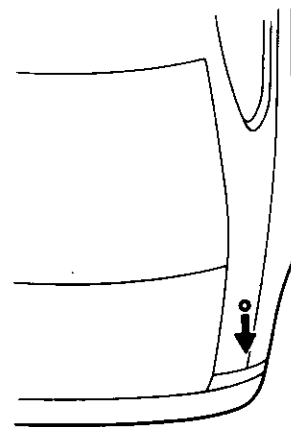

4. Check for engagement of the cable teeth to the drive gear by carefully moving the cable up and down.
5. Turn the radio switch "OFF", and let the motor pull the drive cable inside the antenna housing.
6. Clean the threads on the antenna mast housing.
7. Insert the antenna mast into the antenna housing, install the bushing and spacer, and tighten the special nut to 2.3 N·m (0.23 kg-m, 1.7 lb-ft).

NOTE: If the special nut is overtightened, the antenna may stick. If sticking occurs, back the nut off until the antenna moves freely.

8. Check that the antenna mast retracts and extends fully when the radio switch is turned ON and OFF repeatedly.



Power Antenna Motor Replacement

1. Remove the trunk right side trim panel.
2. Disconnect the 3-P connector and antenna lead from the motor, then remove the special nut and mounting nut, and take out the motor with the antenna mast.

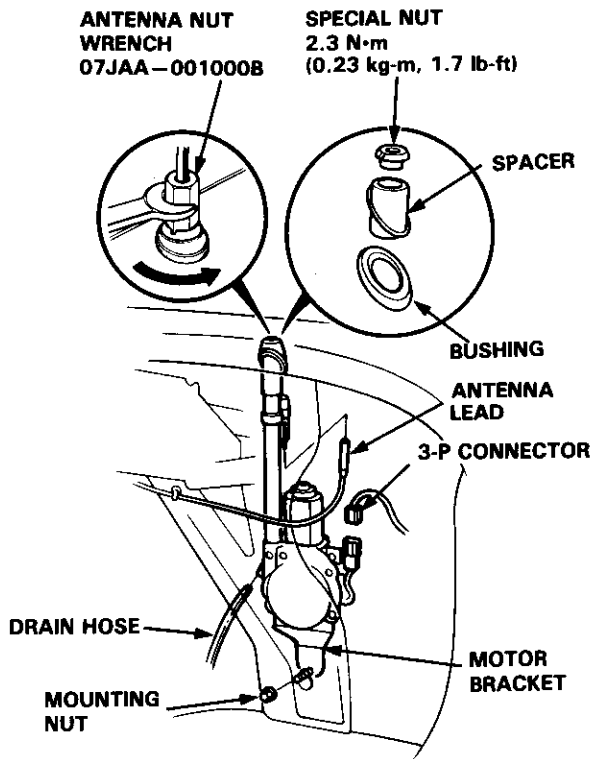

3. When installing the new antenna, tighten the special nut first, then tighten the mounting nut on the motor bracket.

Door Speaker Replacement

1. Remove the door panel.
2. Remove the four screws, then disconnect the 2-P connector from the speaker, and remove the speaker.

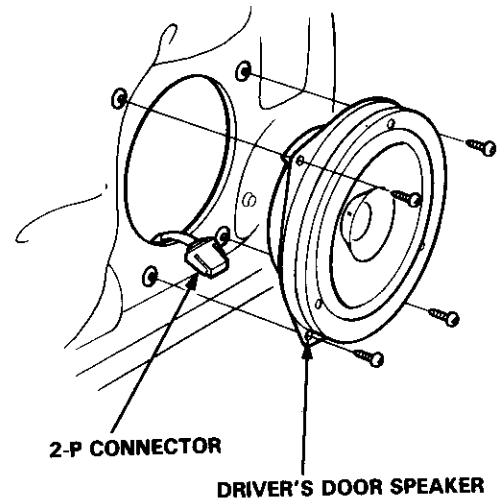

Stereo Sound System

Rear Speaker Replacement

1. Remove the three nuts from inside the trunk, then disconnect the connector and remove the speaker assembly.

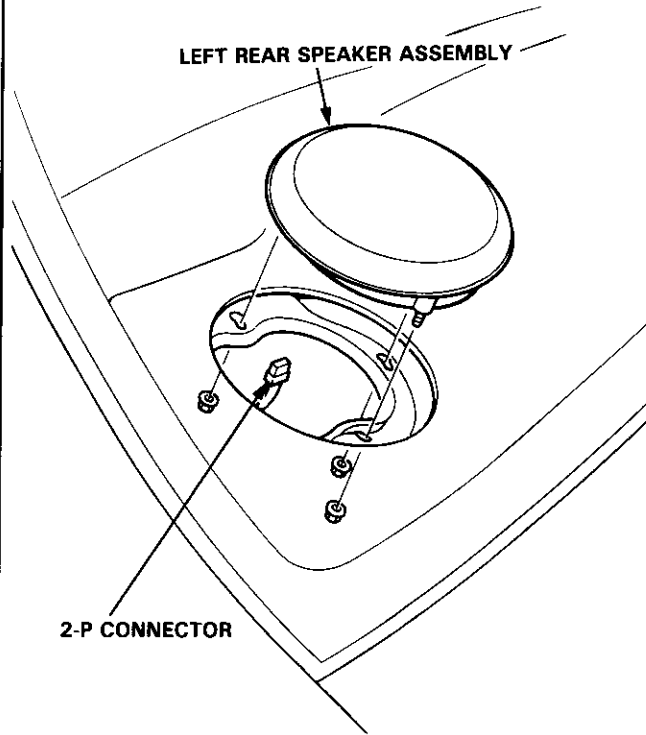

2. Remove the three screws from the adapter, then remove the speaker cover.
3. Remove the three screws, then remove the speaker from the adapter.

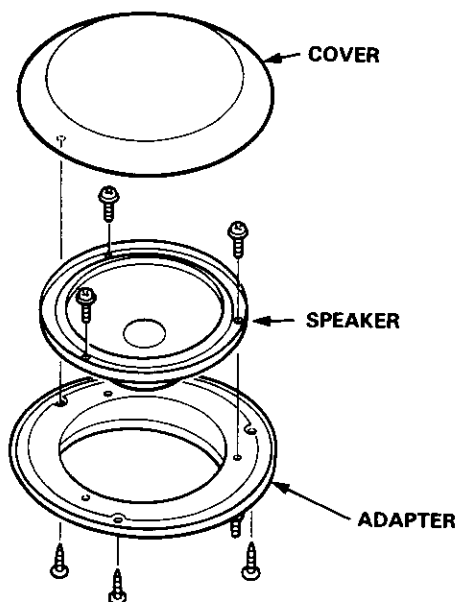

Tweeter Replacement

1. Carefully pry the tweeter cover out of the dashboard, then disconnect the connectors from the speaker.

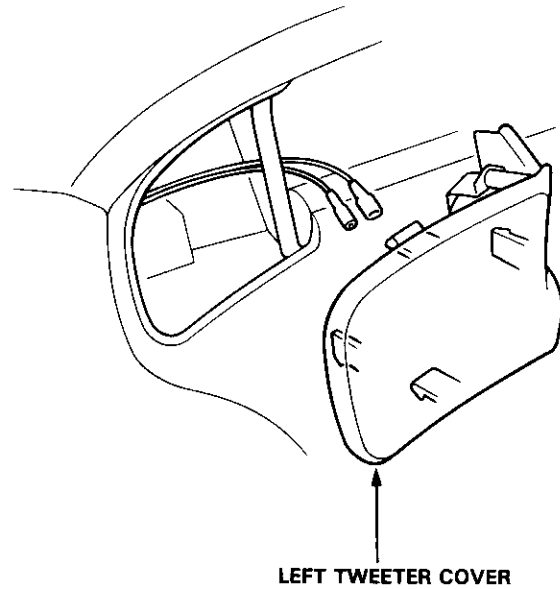

2. Remove the two screws and remove the tweeter from the cover.

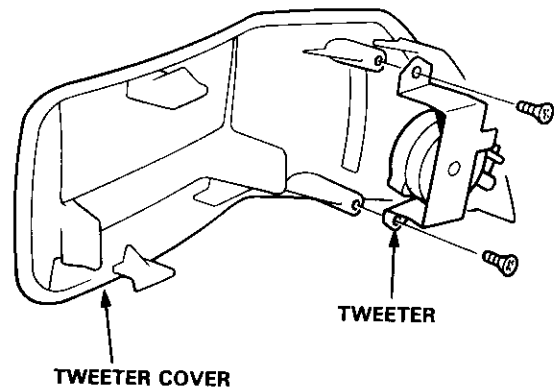



Woofer Replacement

1. Remove the rear seat upper trim panel (see section 20).

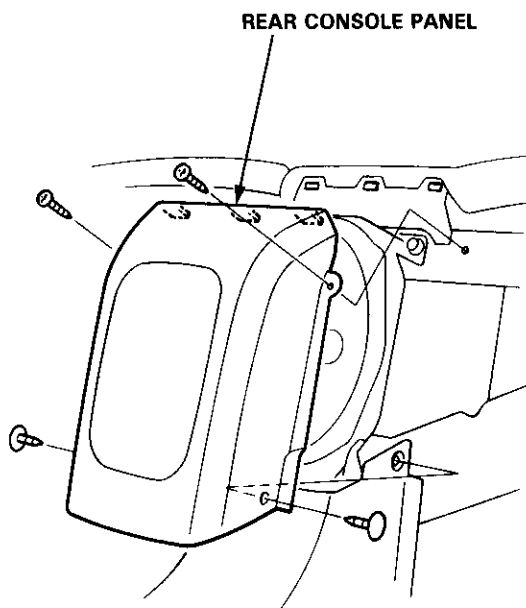

2. Remove the four screws and disconnect the 2-P connector from the speaker, then replace the speaker.

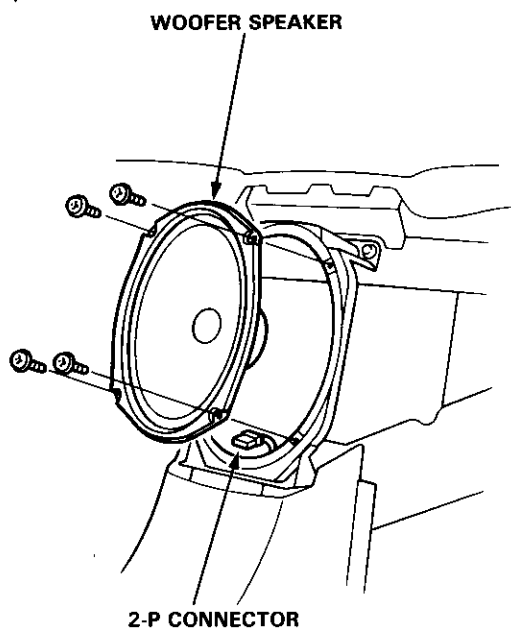

Clock

Circuit Diagram

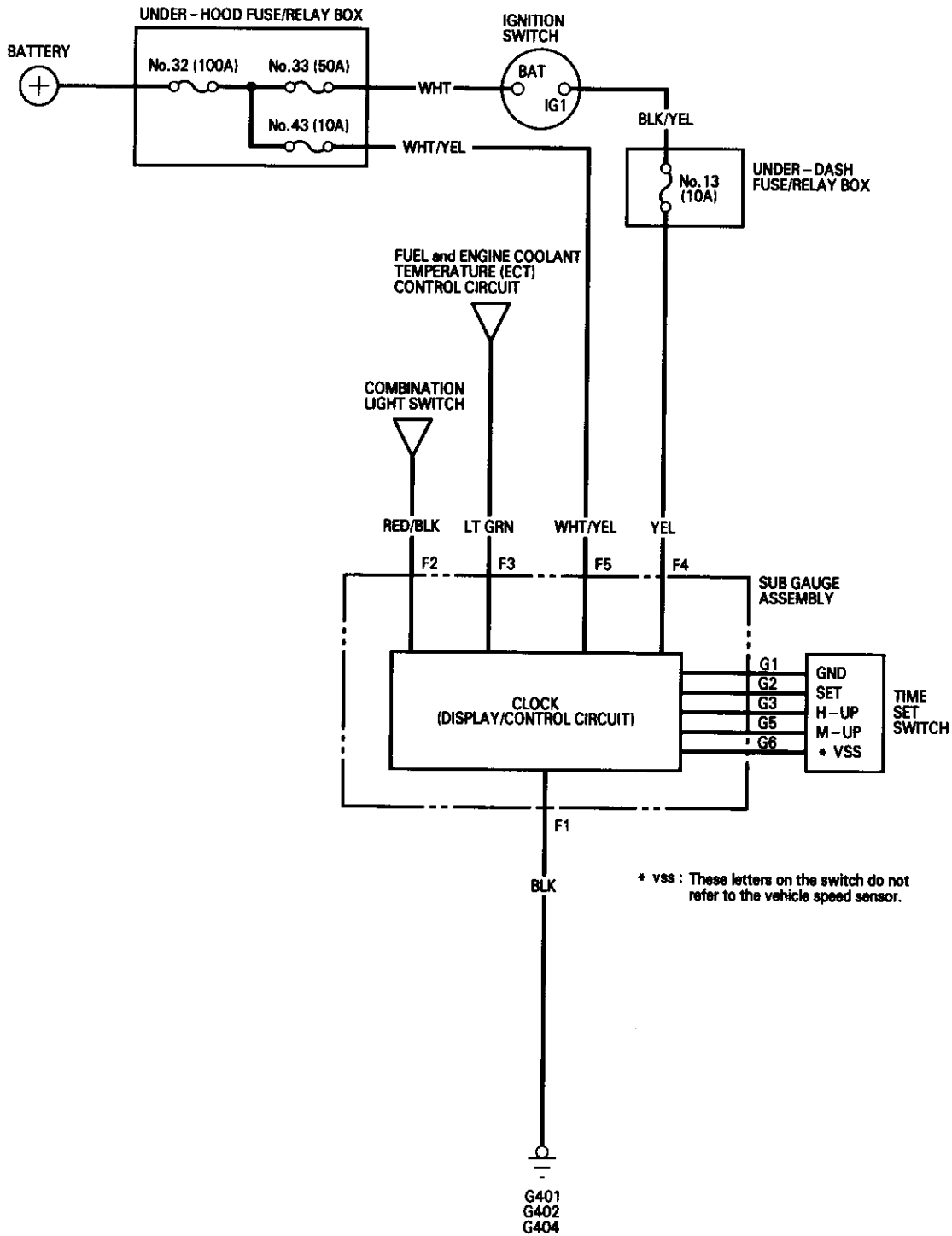



Removal/Terminals

CAUTION:

- All SRS electrical wiring harnesses are covered with yellow outer insulation.
- Before disconnecting the SRS wire harness, install the short connector(s) on the airbag(s) (see page 23-294).
- Replace the entire affected SRS harness assembly if it has an open circuit or damaged wiring.
- After installing the gauge assembly, recheck the operation of the SRS indicator light.

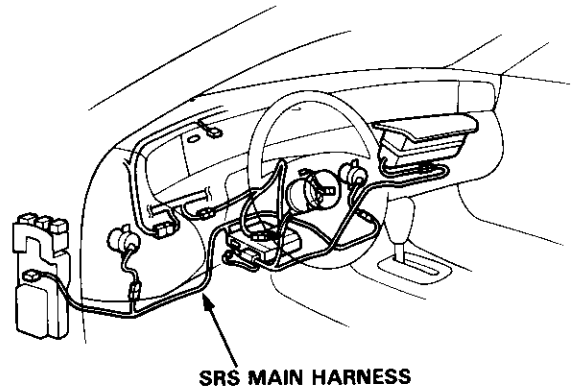

Removal:

1. Remove the right tweeter cover (see page 23-130).
2. Remove the instrument panel visor (see page 23-130).
3. Remove the black face panel (see page 23-130).
4. Remove the sub gauge assembly (see page 23-131).

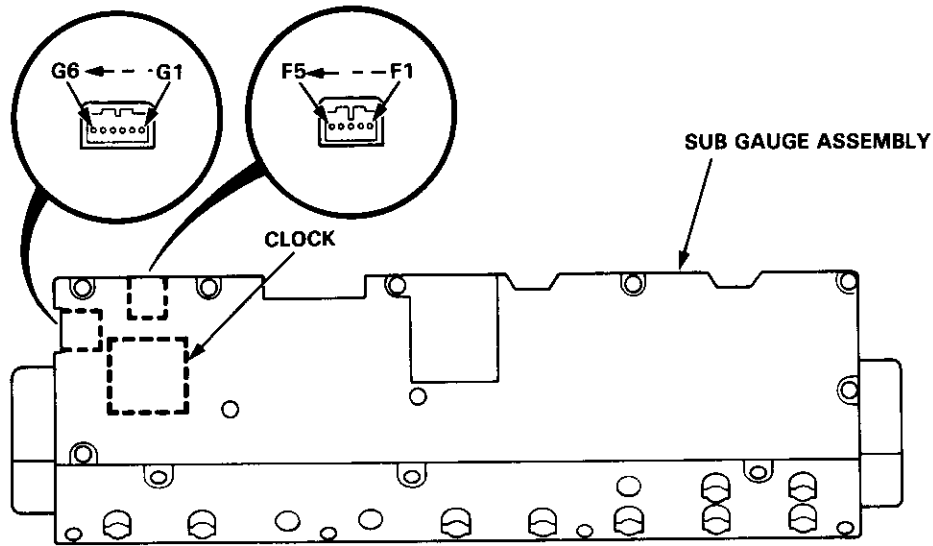

Terminals:

Terminal	Wire	Connects to
F1	BLK	Ground
F2	RED/BLK	Combination light switch
F3	LT GRN	Display control circuit
F4	YEL	IG1 (Main clock power supply)
F5	WHT/YEL	Constant power (Time memory)

Terminal

Connects to

Terminal	Connects to
G1	Ground
G2	"00" SET
G3	"H" UP
G4	
G5	"M" UP
G6	**"VSS"

NOTE: These letters on the switch do not refer to the Vehicle Speed Sensor.

Horns

Component Location Index

CAUTION:

- All SRS electrical wiring harnesses are covered with yellow outer insulation.
- Before disconnecting the SRS wire harness, install the short connector(s) on the airbag(s) (see page 23-294).
- Replace the entire affected SRS harness assembly if it has an open circuit or damaged wiring.

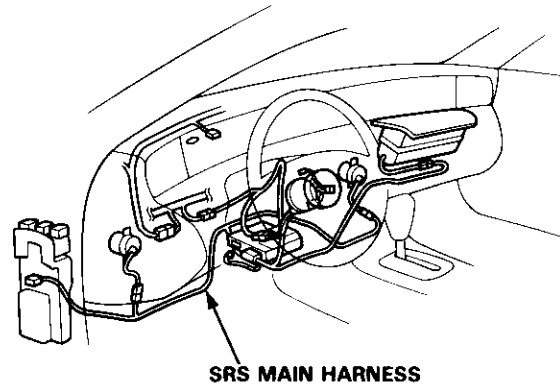

• HORNS

Test, page 23-221

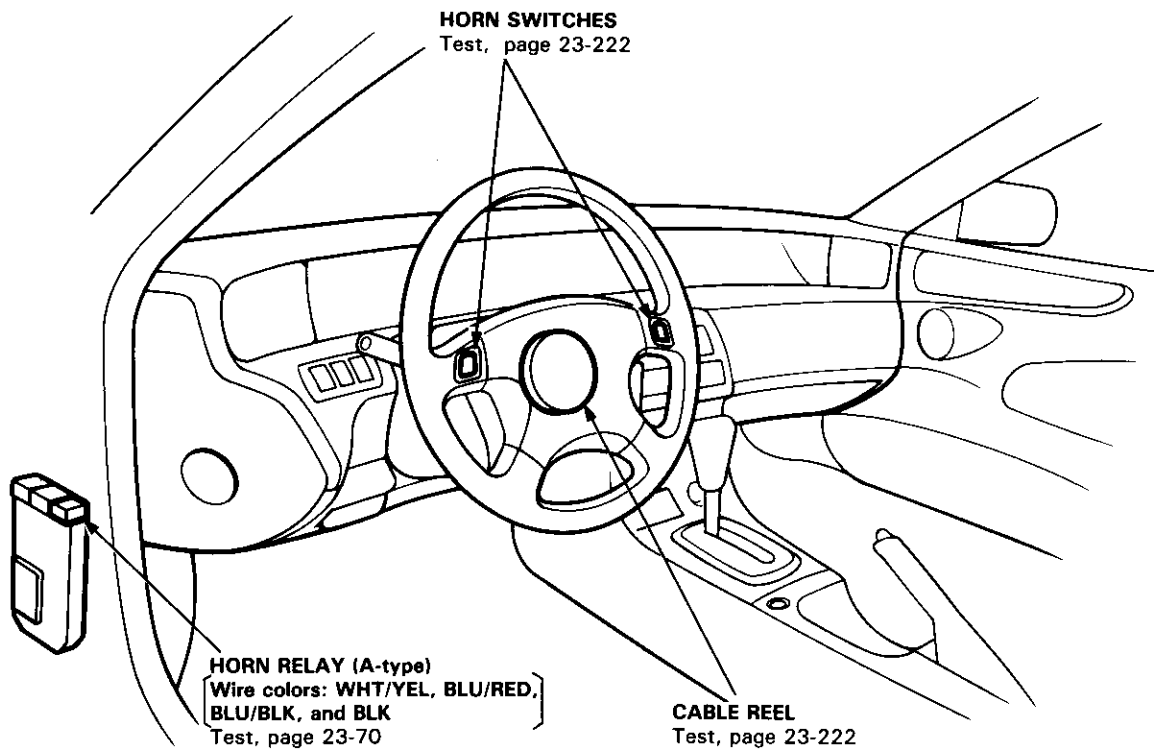



Circuit Diagram

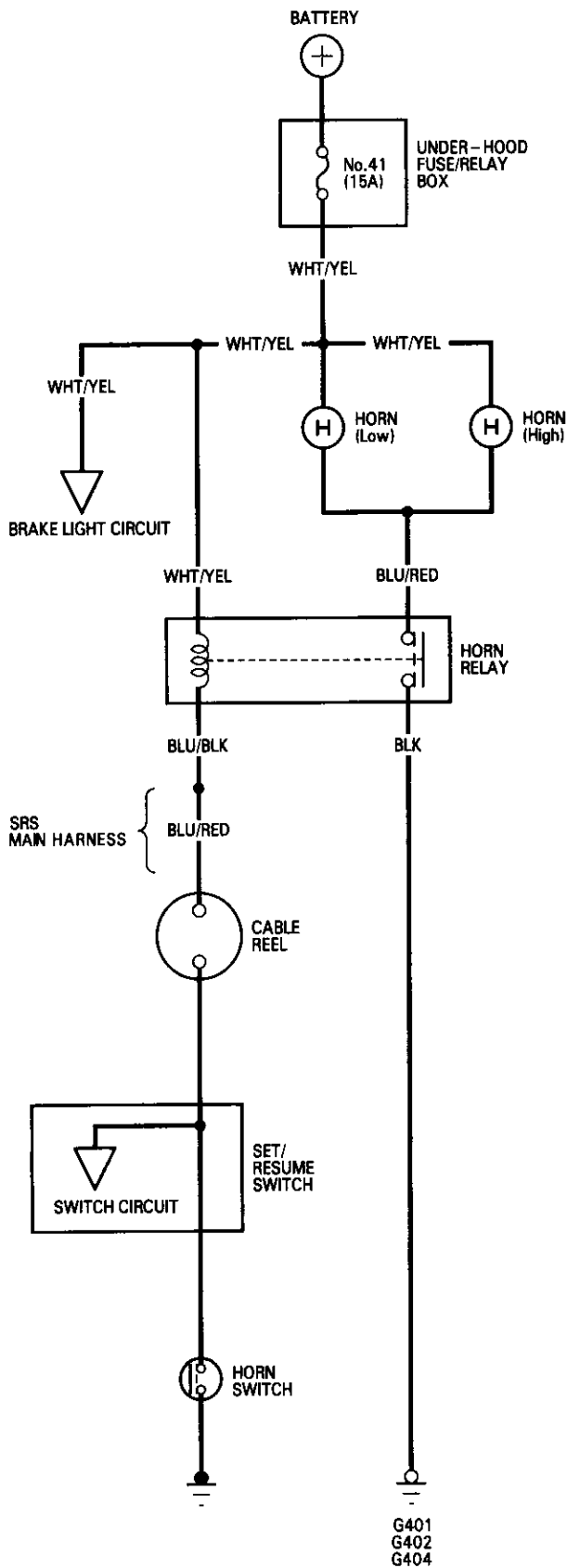

Test

1. Disconnect the 2-P connector and remove the horn.
2. Test the horn by connecting battery power to one terminal and grounding the other. The horn should sound.

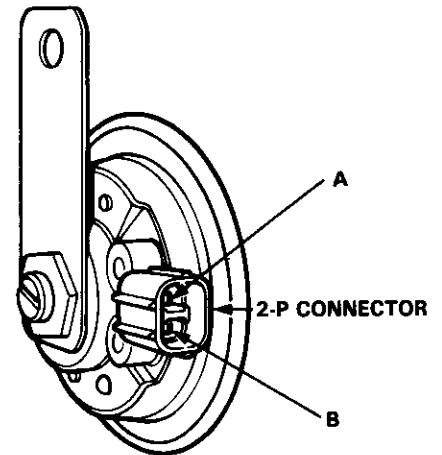

3. If it fails to sound; replace it.

Horns

Switch Test

CAUTION:

- All SRS electrical wiring harnesses are covered with yellow outer insulation.
- Before disconnecting the SRS wire harness, install the short connector(s) on the airbag(s) (see page 23-294).
- Replace the entire affected SRS harness assembly if it has an open circuit or damaged wiring.

NOTE: The radio may have a coded theft protection circuit. Be sure to get the customer's code number before

- Disconnecting the battery.
- Removing the No. 43 (10 A) fuse. (In the under-hood fuse/relay box)
- Removing the radio.

After service, reconnect power to the radio and turn it on.

When the word "CODE" is displayed, enter the customer's 5-digit code to restore radio operation.

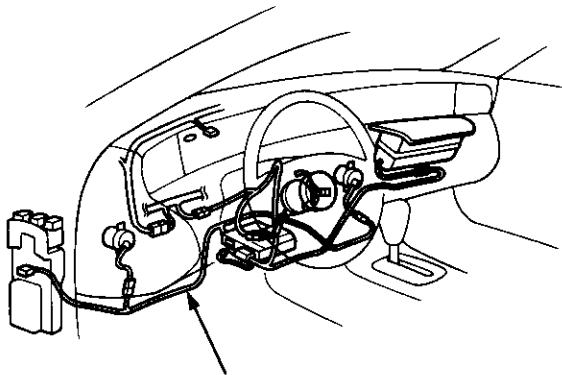

SRS MAIN HARNESS

1. Disconnect the battery negative cable, and then positive cable.
2. Make sure the wheels are turned straight ahead.
3. Remove the two screws and access panel, then remove the short connector from the access panel.
4. Disconnect the airbag connector and cable reel connector.

5. Install the short connector on the airbag connector.

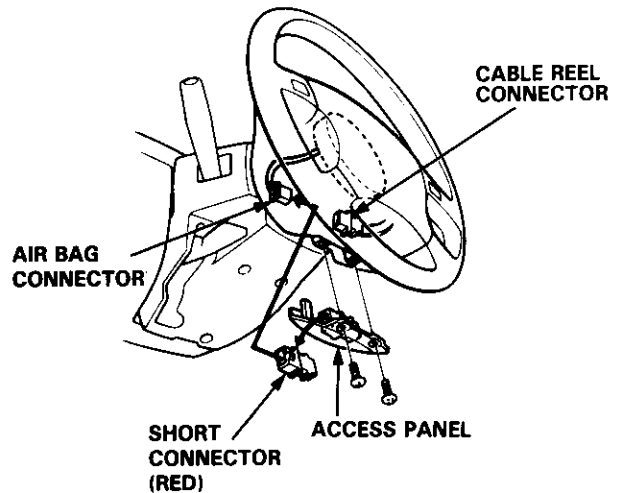

6. Remove the dashboard lower cover.
7. Disconnect the cable reel 6-P connector from the SRS main harness, then connect Test Harness C only to the cable reel side of the 6-P connector.

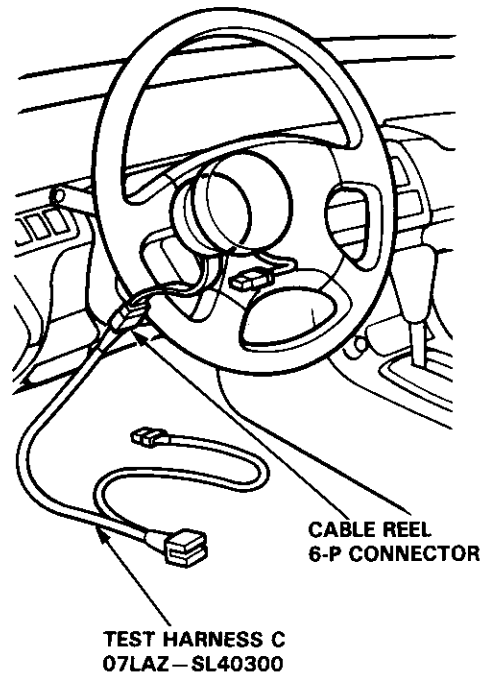



8. Check for continuity between the No. 3 terminal of the 8-P connector of Test Harness C and body ground with the horn switch pressed.

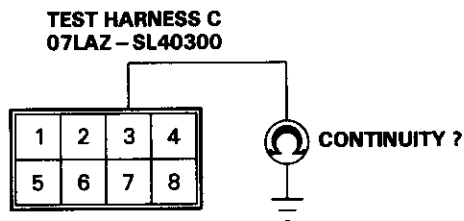

- If there is continuity, the horn switch is OK.
- If there is no continuity, go to step 9.

9. Carefully remove the cruise control SET/RESUME switch cover by prying between the cover and switch in the sequence shown.

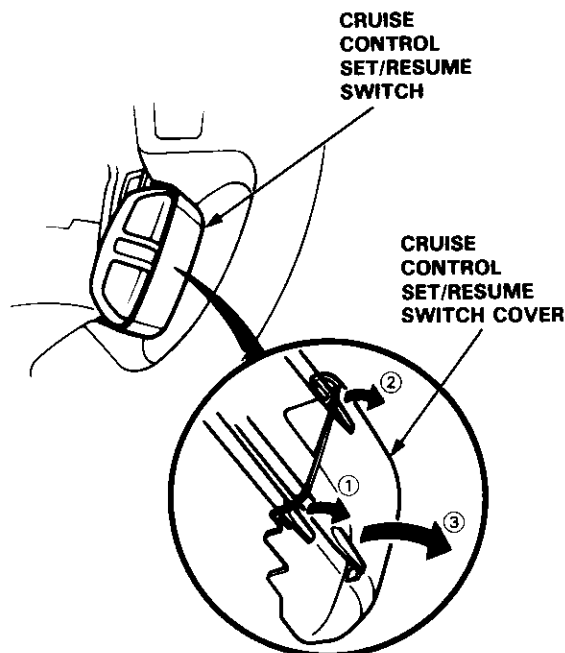

10. Remove the two TORX® bolts using a TORX® T30 bit, then remove the driver's airbag assembly.

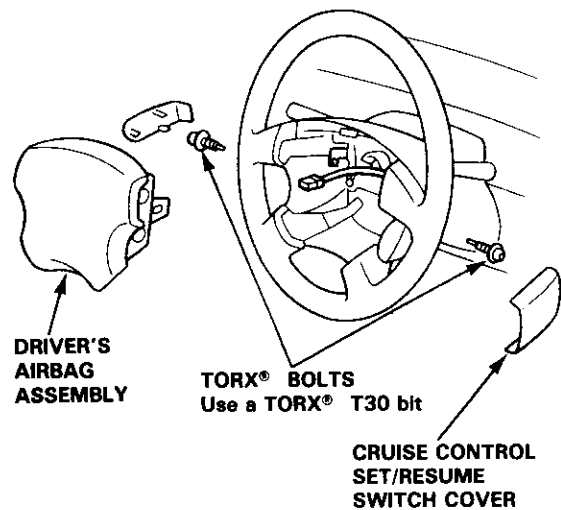

11. Check for continuity between the horn positive terminal and steering shaft with the horn switch pressed.

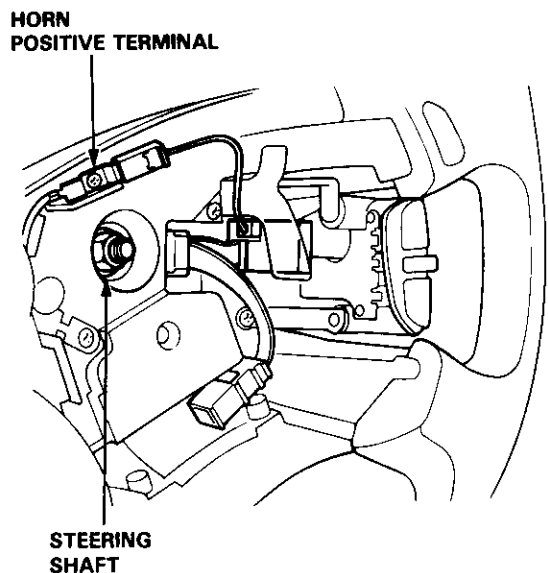

- If there is continuity;
 - Check the cable reel.
 - Check the SET/RESUME switch.
- If there is no continuity, replace the horn switch (see section 17).

Cigarette Lighter

Component Location Index

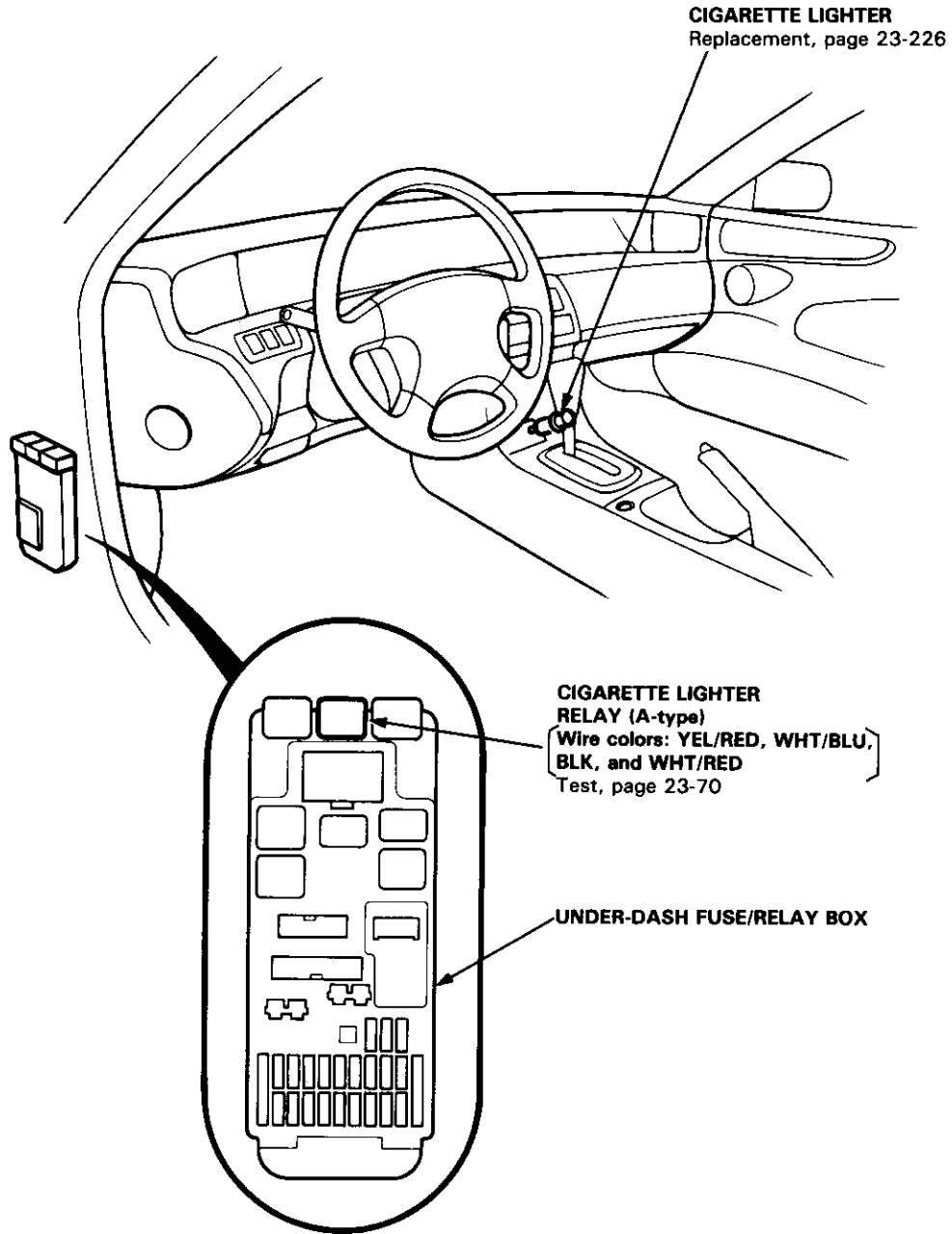



Circuit Diagram

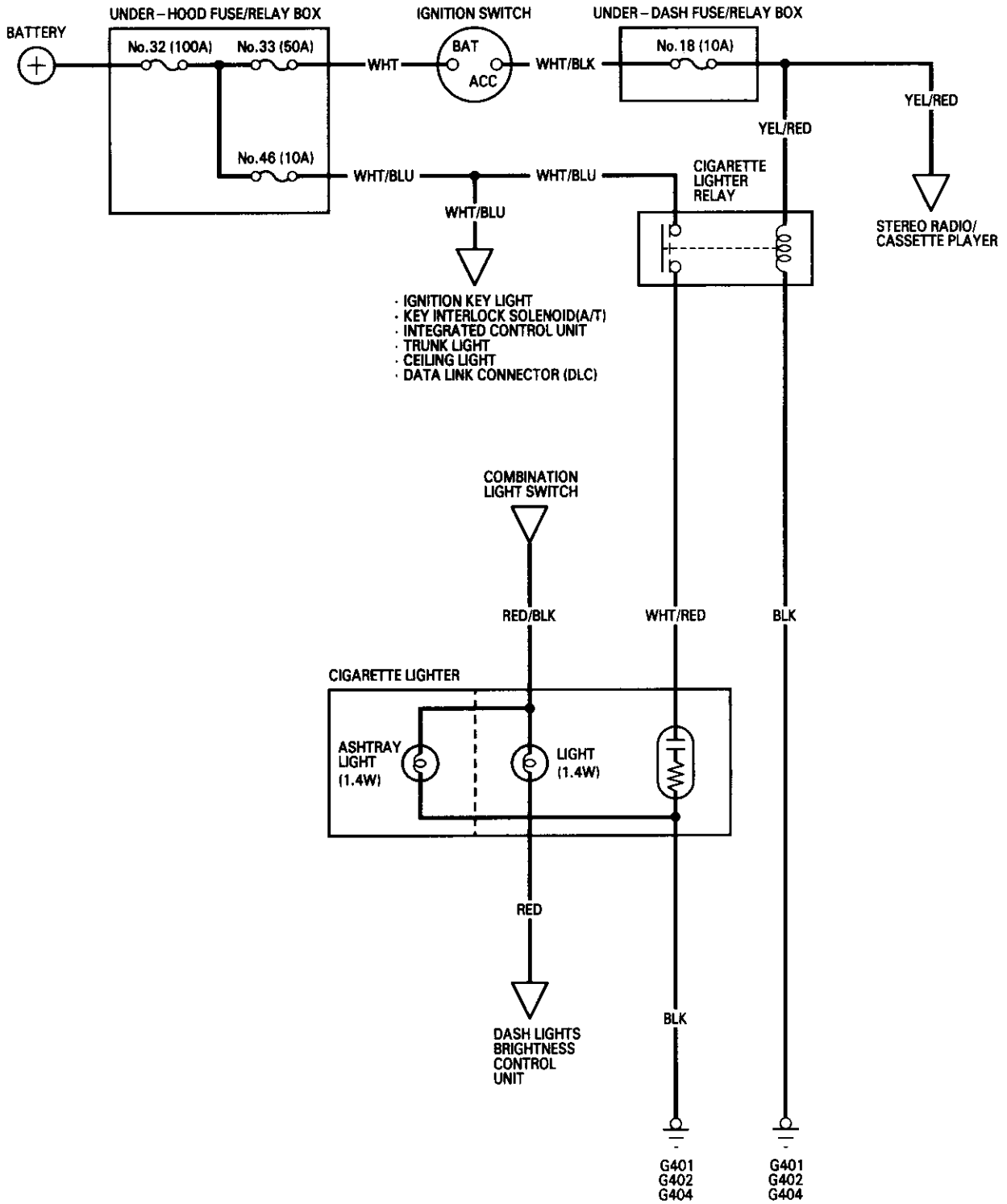

Cigarette Lighter

Replacement

CAUTION:

- All SRS electrical wiring harnesses are covered with yellow outer insulation.
- Before disconnecting the SRS wire harness, install the short connector(s) on the airbag(s) (see page 23-294).
- Replace the entire affected SRS harness assembly if it has an open circuit or damaged wiring.

NOTE: The radio may have a coded theft protection circuit. Be sure to get the customer's code number before

- Disconnecting the battery.
- Removing the No. 43 (10 A) fuse. (In the under-hood fuse/relay box)
- Removing the radio.

After service, reconnect power to the radio and turn it on.

When the word "CODE" is displayed, enter the customer's 5-digit code to restore radio operation.

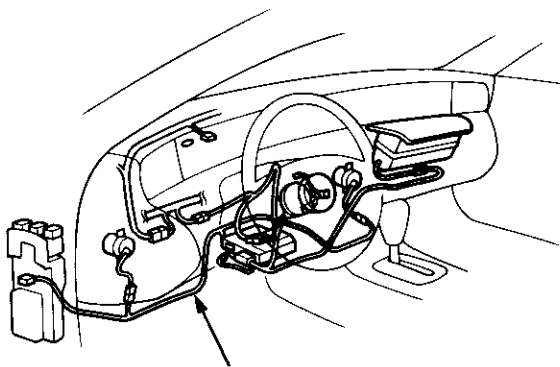

SRS MAIN HARNESS

1. Remove the front console (see section 20).
2. Remove the radio panel assembly (see page 23-210).

3. Disconnect the thermofuse housing from the socket.

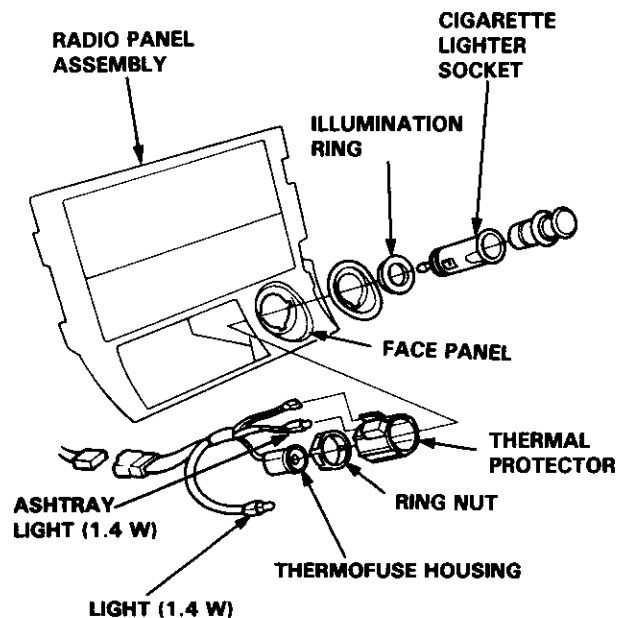

4. Remove the ring nut and separate the cigarette lighter socket from the thermal protector.
5. When installing the cigarette lighter, align each lug on the face panel, illumination ring, and cigarette lighter socket with the groove in the hole, then position the bulb housing on the thermal protector between the stops in the radio panel.
6. Make sure that the ground wire, bulb socket, and thermofuse housing are seated against the cigarette lighter assembly.



Rear Window Defogger

Component Location Index

CAUTION:

- All SRS electrical wiring harnesses are covered with yellow outer insulation.
- Before disconnecting the SRS wire harness, install the short connector on the airbag(s), then disconnect the wire harness (see page 23-294).
- Replace the entire affected SRS harness assembly if it has an open circuit or damaged wiring.

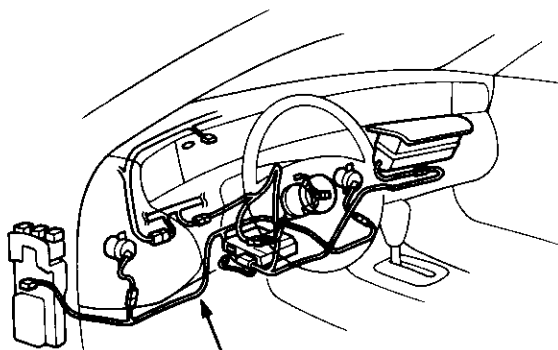

SRS MAIN HARNESS

REAR WINDOW DEFOGGER SWITCH
 Test, page 23-230
 Replacement, page 23-230

UNDER-DASH FUSE/RELAY BOX

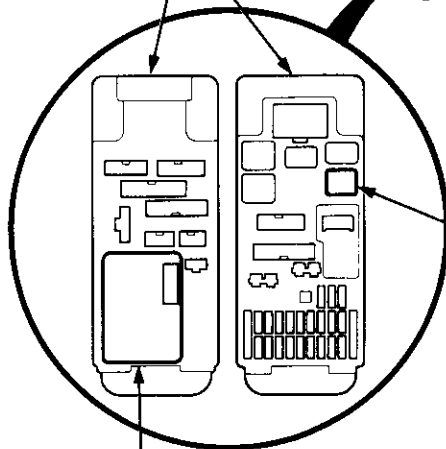

DEFOGGER TIMER CIRCUIT
 (In the integrated control unit)
 Input Test, page 23-170

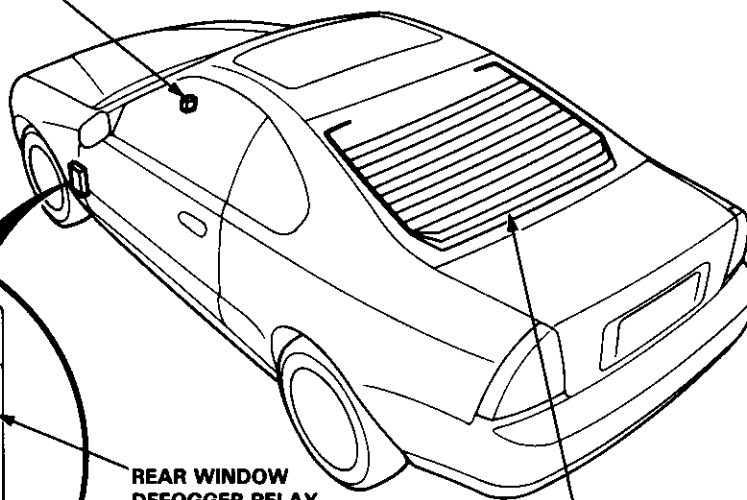

REAR WINDOW DEFOGGER RELAY (A-Type)
 Test, page 23-71

REAR WINDOW DEFOGGER
 Function Test, page 23-231

Description

The rear window defogger is controlled by the integrated control unit. When the defogger switch in the heater control panel is pushed, it sends a signal to the defogger timer in the integrated control unit and the defogger stays on for about 25 minutes, or until the ignition is switched off.

The indicator light in the switch comes on when the defogger is ON.

Rear Window Defogger

Circuit Diagram

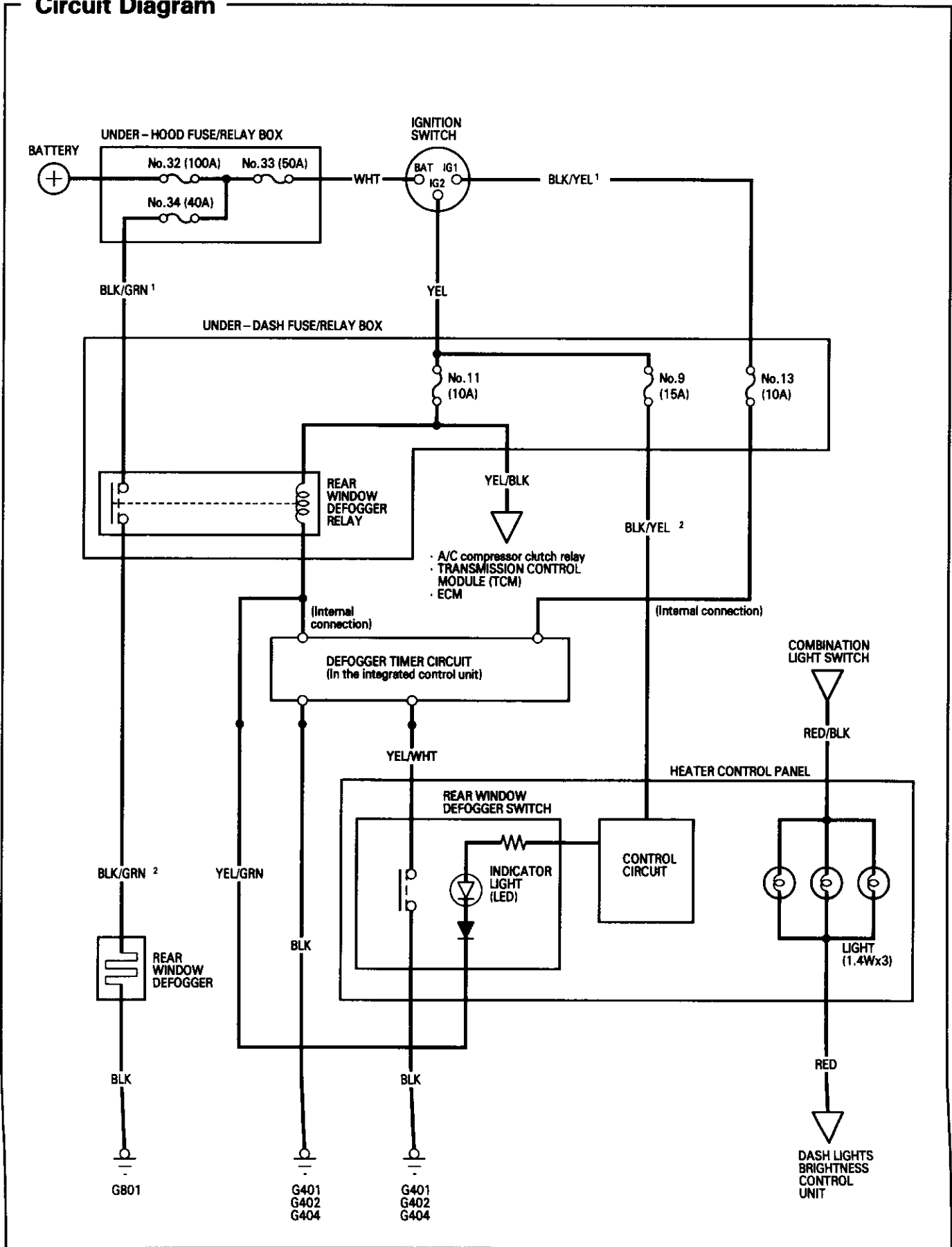



Troubleshooting

NOTE: The numbers in the table show the troubleshooting sequence.

Item to be inspected	Blown indicator light bulb	Blown No. 9 (15 A) fuse (In the under-dash fuse/relay) box	Blown No. 11 (10 A) fuse (In the under-dash fuse/relay box)	Blown No. 13 (10 A) fuse (In the under-dash fuse/relay box)	Control circuit (In the heater control panel)	Blown No. 34 (40 A) fuse (In the under-hood fuse/relay box)	Defogger timer circuit input (In the integrated control unit)	Function test	Defogger relay	Broken defogger wire	Poor ground	Open circuit, loose or disconnected terminals
Defogger works, but indicator light does not go on.	1	2			3							BLK/YEL ² YEL/GRN
Defogger does not work and indicator light does not go on.				3			2	1				YEL
Defogger does not work, but indicator light goes on.			2			1		5	3	4	G401 G402 G404 G801	BLK/GRN ¹ , YEL/WHT BLK/GRN ²
Defogger-on time too long or too short compared with the normal ON time (25 minutes).							1				G401 G402 G404	YEL/WHT

Rear Window Defogger

Switch Replacement

1. Remove the front console (see section 20).
2. Remove the stereo radio/cassette player (see page 23-210).
3. Disconnect the air mix cable from the heater.

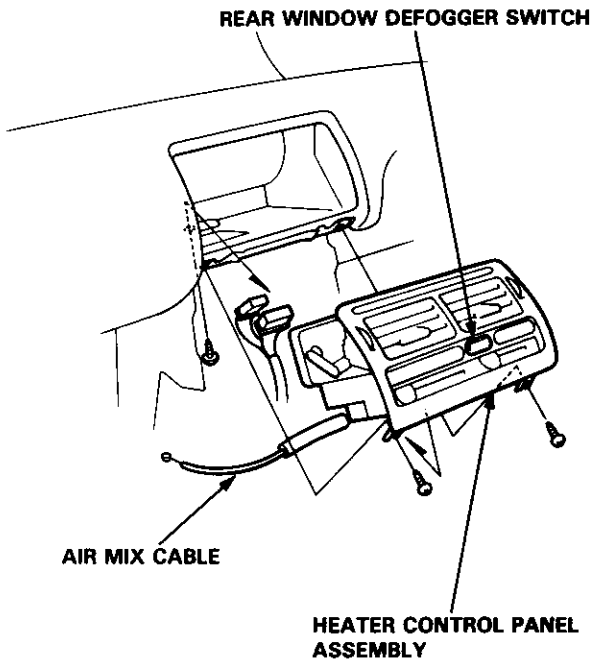

4. Remove the two mounting screws and disconnect the connectors, then remove the heater control panel.
5. Install in the reverse order of removal.
6. After installing the control panel, connect the air mix cable (see section 22), and make sure the temperature control function works correctly.

Switch Test

1. Remove the heater control panel.
2. Check for continuity between the terminals according to the table.

Terminal	11	14	16			12
Position						
ON	○	○				
OFF			○	⊗	⊗	○

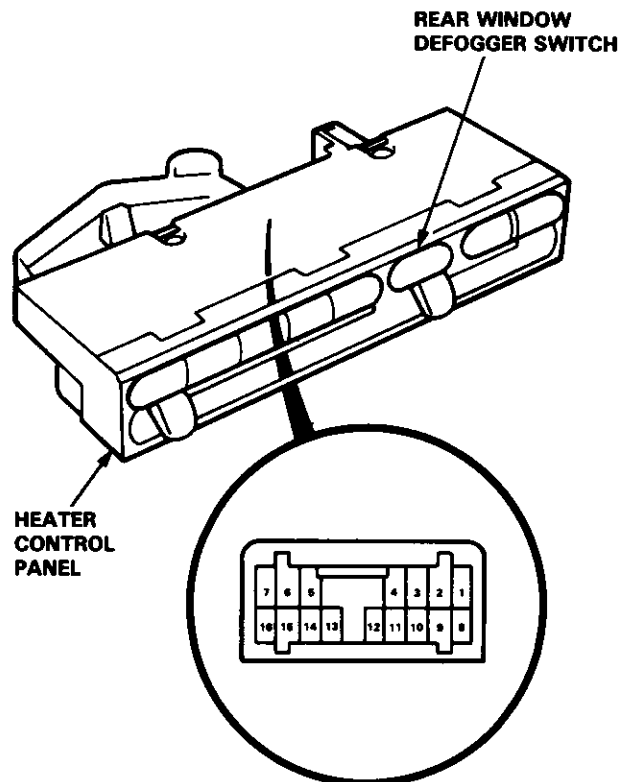
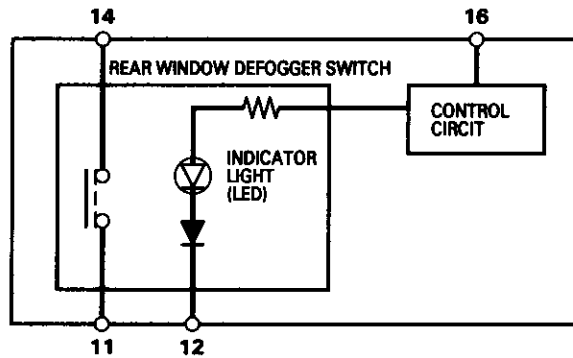



Function Test

CAUTION: Be careful not to scratch or damage the defogger wires with the tester probe.

1. Check for voltage between the positive terminal and body ground with the ignition switch and defogger switches ON.
There should be battery voltage.

- If there is no voltage, check for:
 - Faulty defogger relay.
 - Faulty defogger switch.
 - Faulty integrated control unit.
 - An open in the GRN/BLK wire.

- If there is battery voltage, go to step 2.

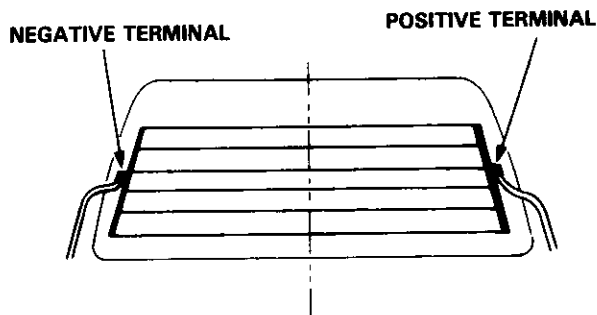

2. Check for continuity between the negative terminal and body ground.
If there is no continuity, check for an open in the defogger ground wire.
3. Touch the voltmeter positive probe to the halfway point of each defogger wire and negative probe to the negative terminal.
There should be approximately 6 V with the ignition switch and defogger switch ON.
 - If the voltage is as specified, the defogger wire is OK.
 - If the voltage is not as specified, repair the defogger.
 - If it is more than 6 V, there is a break in the negative half of the wire.
 - If it is less than 6 V, there is a break in the positive half of the wire.

Defogger Wires Repair

NOTE: To make an effective repair, the broken section must be no longer than one inch.

1. Lightly rub the area around the break with fine steel wool, then clean it with alcohol.
2. Carefully mask above and below the broken portion of the defogger wire with cellophane tape.

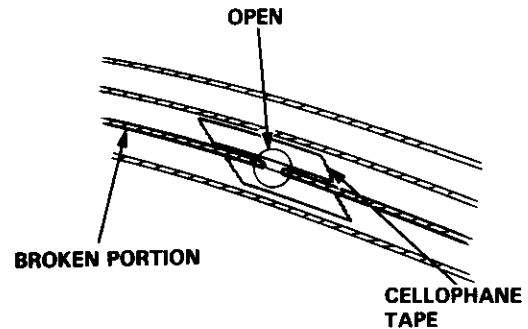

3. Using a small brush, apply a heavy coat of silver conductive paint extending about 1/8" (3 mm) on both sides of the break. Allow 30 minutes to dry.

NOTE: Thoroughly mix the paint before use.

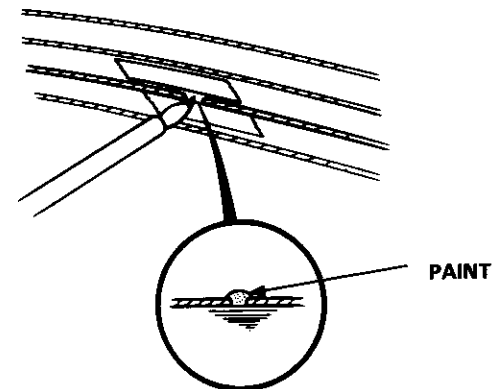

4. Check for continuity in the repaired wire.
5. Apply a second coat of paint in the same way. Let it dry three hours before removing the tape.

Seat Heaters (Canada)

Component Location Index

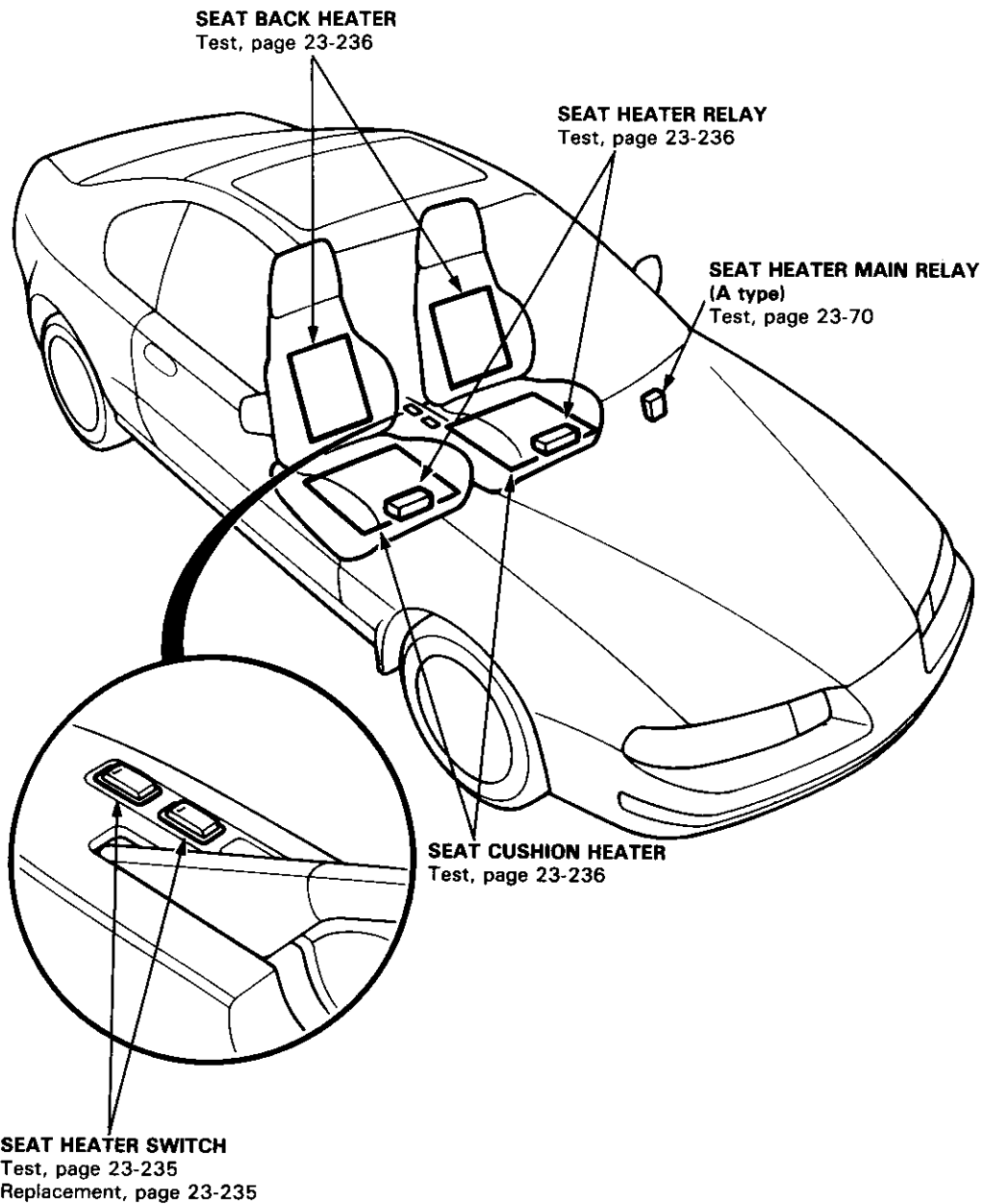

Description

Two heaters are provided in each front seat; one in the seat cushion and another in the seat back. In normal use, temperature is automatically controlled by the thermostat [OFF above 104°F (40°C)] built into each seat cushion heater. Breaker 1 [OFF above 122°F (50°C)] and breaker 2 [OFF above 158°F (70°C)] cut off the circuit to prevent abnormal temperature rise.



Circuit Diagram

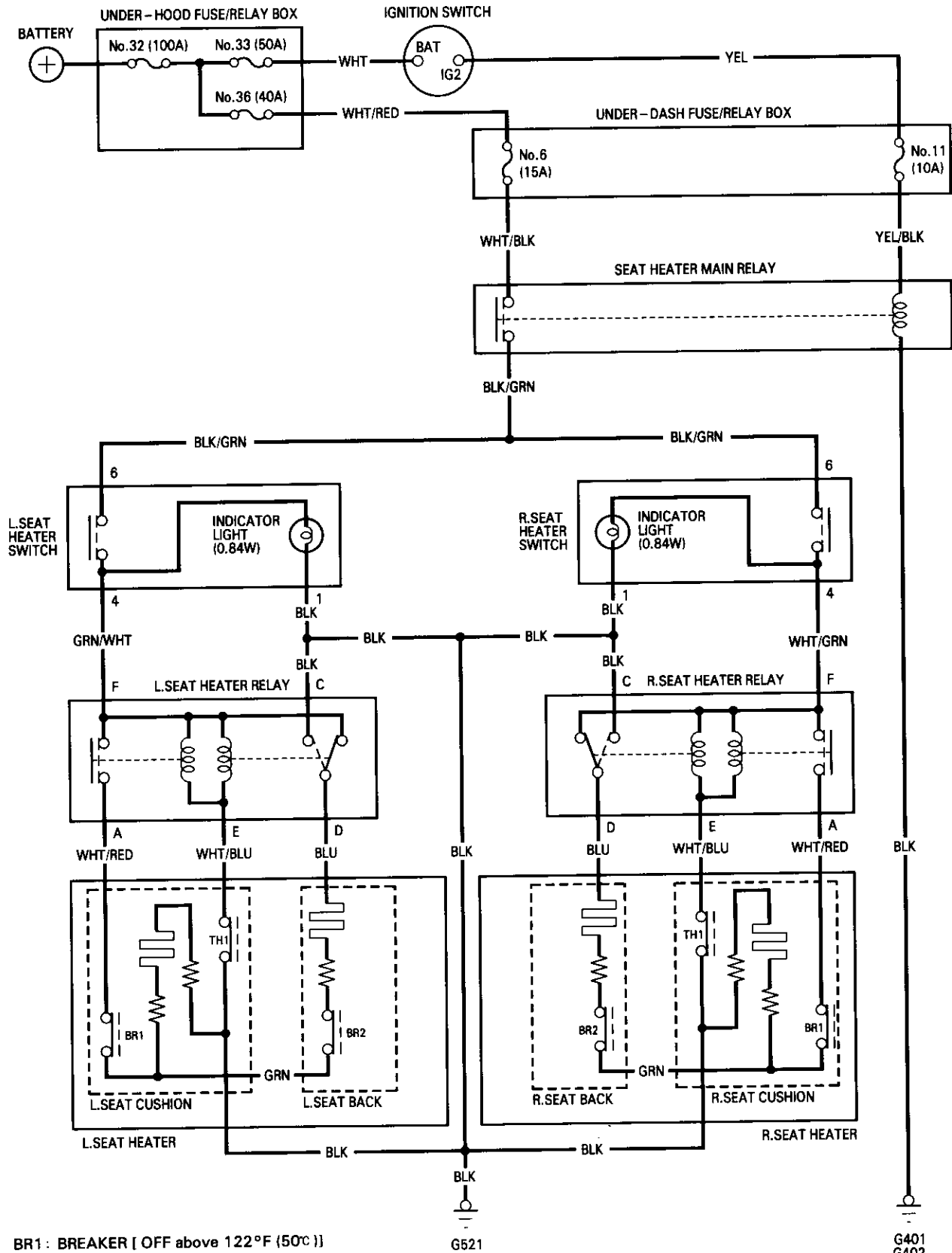

BR1: BREAKER [OFF above 122°F (50°C)]
 TH1: THERMOSTAT [OFF above 104°F (40°C)]
 BR2: BREAKER [OFF above 158°F (70°C)]

G401
 G402
 G404

Seat Heaters (Canada)

Troubleshooting

NOTE: The numbers in the table show the troubleshooting sequence.

Item to be inspected		Blown No. 36 (40 A) fuse (In the under-hood fuse/relay box)	Blown No. 6 (15 A) fuse (In the under-dash fuse/relay box)	Blown No. 11 (10 A) fuse (In the under-dash fuse/relay box)	Blown indicator light bulb	Seat heater switch	Seat heater	Seat heater main relay input	Seat heater relay input	Poor ground	Open circuit, loose or disconnected terminals.
Seat heaters work, but indicator light does not go on.					1						BLK
Seat heaters do not work and indicator light does not go on.		1				2		3		G401 G402 G404 G521	WHT/BLK, BLK/GRN YEL/BLK, WHT/RED
Seat heaters do not work, but indicator light goes on.	Left or right seat								1		GRN/WHT, WHT/GRN, BLU, WHT/RED, WHT/BLU
Seat cushion heater or seat back heater does not work, but indicator light goes on.							1		2		BLU, GRN



Switch Replacement

1. Pry the switch out of the center console panel.
2. Disconnect the 6-P connector from the switch.

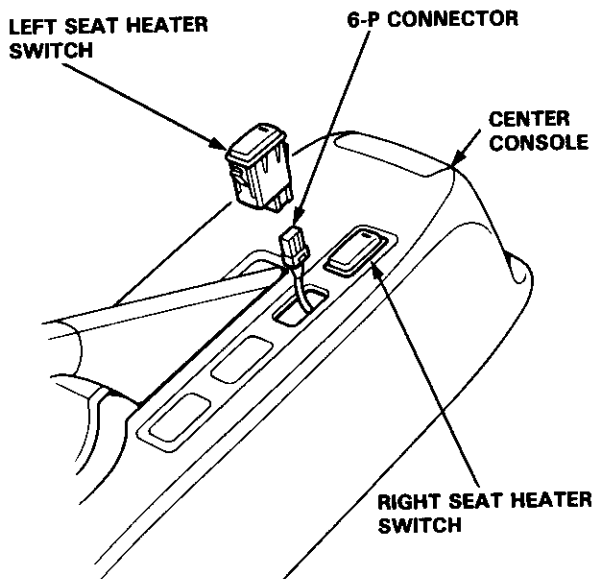

Switch Test

1. Remove the seat heater switch from the center console.
2. Check for continuity between the terminals according to the table.

Terminal	1		4	6
Position				
ON	○	⊖	○	○
OFF	○	⊖	○	

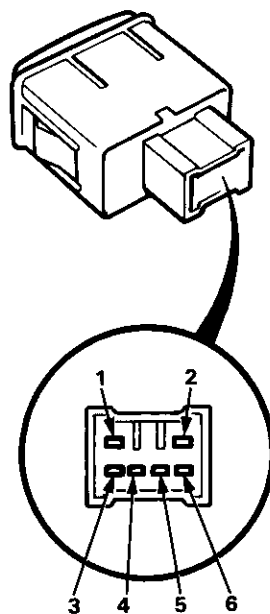

NOTE: Left and right seat heater switches are the same.

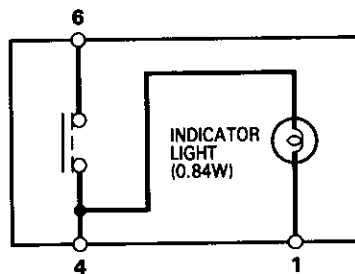

Seat Heaters (Canada)

Heater Test

1. Disconnect the 6-P and 4-P connectors as shown below.

NOTE: Left front seat is shown. Right front seat is similar.

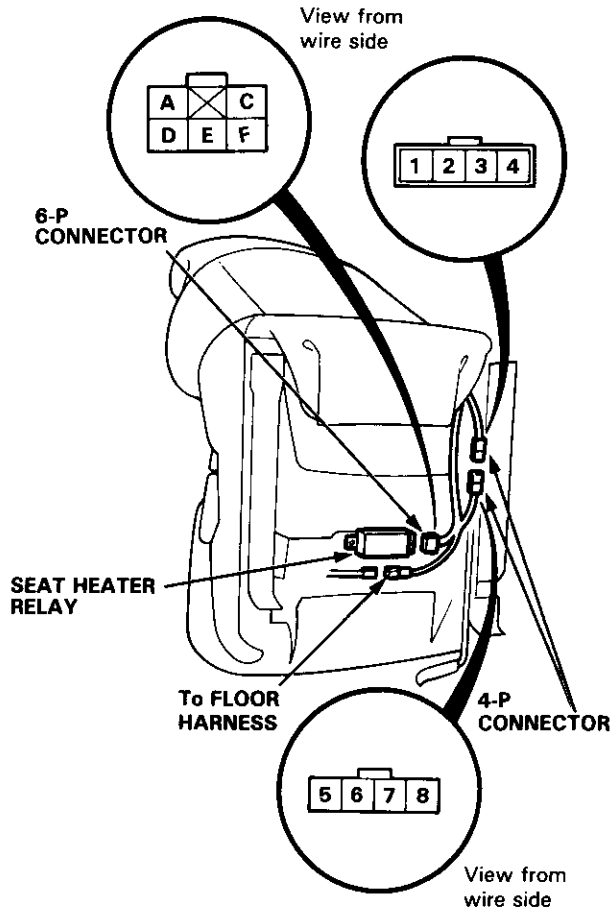

2. **Seat cushion heater:**
Check for continuity between the No. 2 and No. 3 terminals ($R \times 10^3$ scale).
There should be continuity.
3. **Seat back heater:**
Check for continuity between the D and No. 8 terminals ($R \times 10^3$ scale).
There should be continuity.

Seat Heater Relay Test

1. Remove the seat, then remove the relay from the bottom of the seat.
2. Check continuity between relay terminals.
 - There should be continuity between the F and A terminals, and the C and D terminals when power and ground are connected to the F and E terminals.
 - There should be continuity between the F and D terminals when power is disconnected.

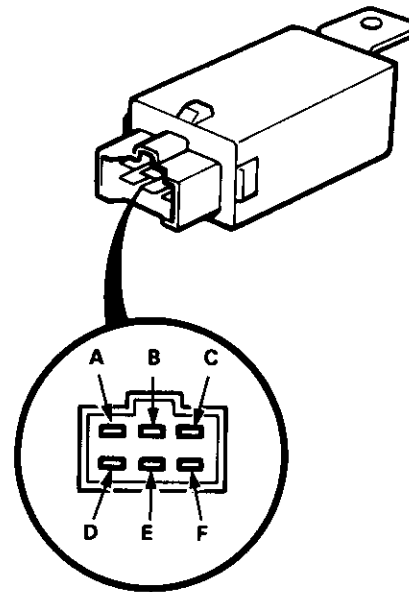

NOTE: Left and right seat heater relays are the same.

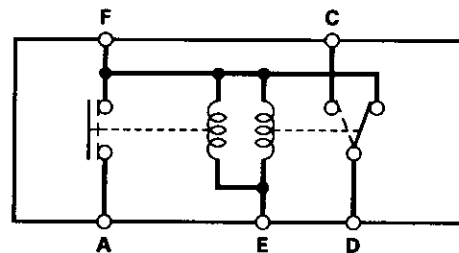



Sunroof

Component Location Index

CAUTION:

- All SRS electrical wiring harnesses are covered with yellow outer insulation.
- Before disconnecting the SRS wire harness, install the short connector(s) on the airbag(s) (see page 23-294).
- Replace the entire affected SRS harness assembly if it has an open circuit or damaged wiring.

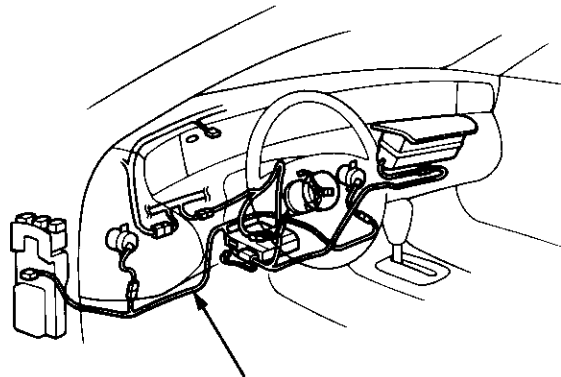

SRS MAIN HARNESS

SUNROOF SWITCH
Test, page 23-240
Removal, page 23-240

SUNROOF MOTOR
Test, page 23-241
Replacement, section 20

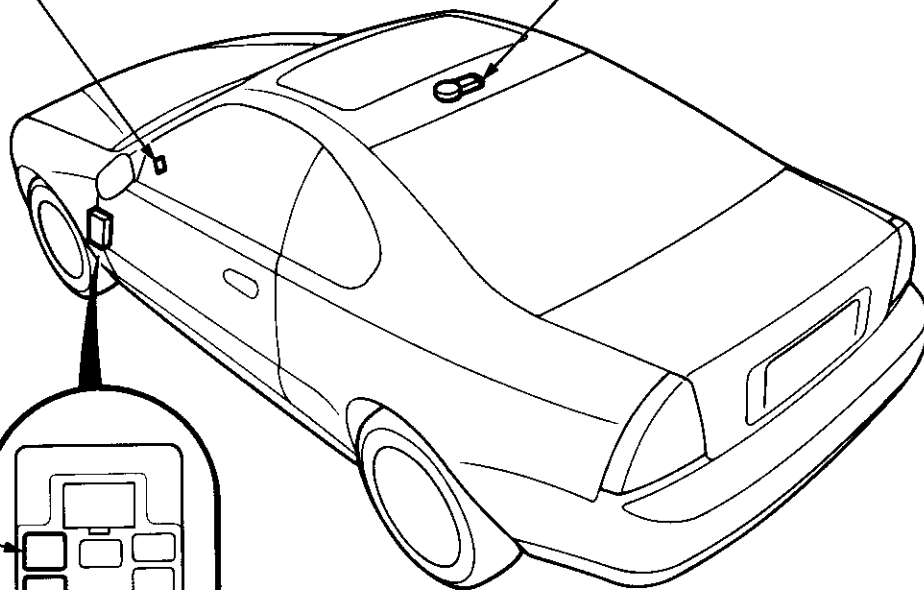

SUNROOF CLOSE RELAY (B type)
Test, page 23-72

SUNROOF OPEN RELAY (B-type)
Test, page 23-72

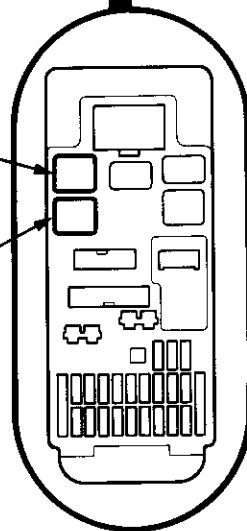

UNDER-DASH FUSE/RELAY BOX

Sunroof

Circuit Diagram

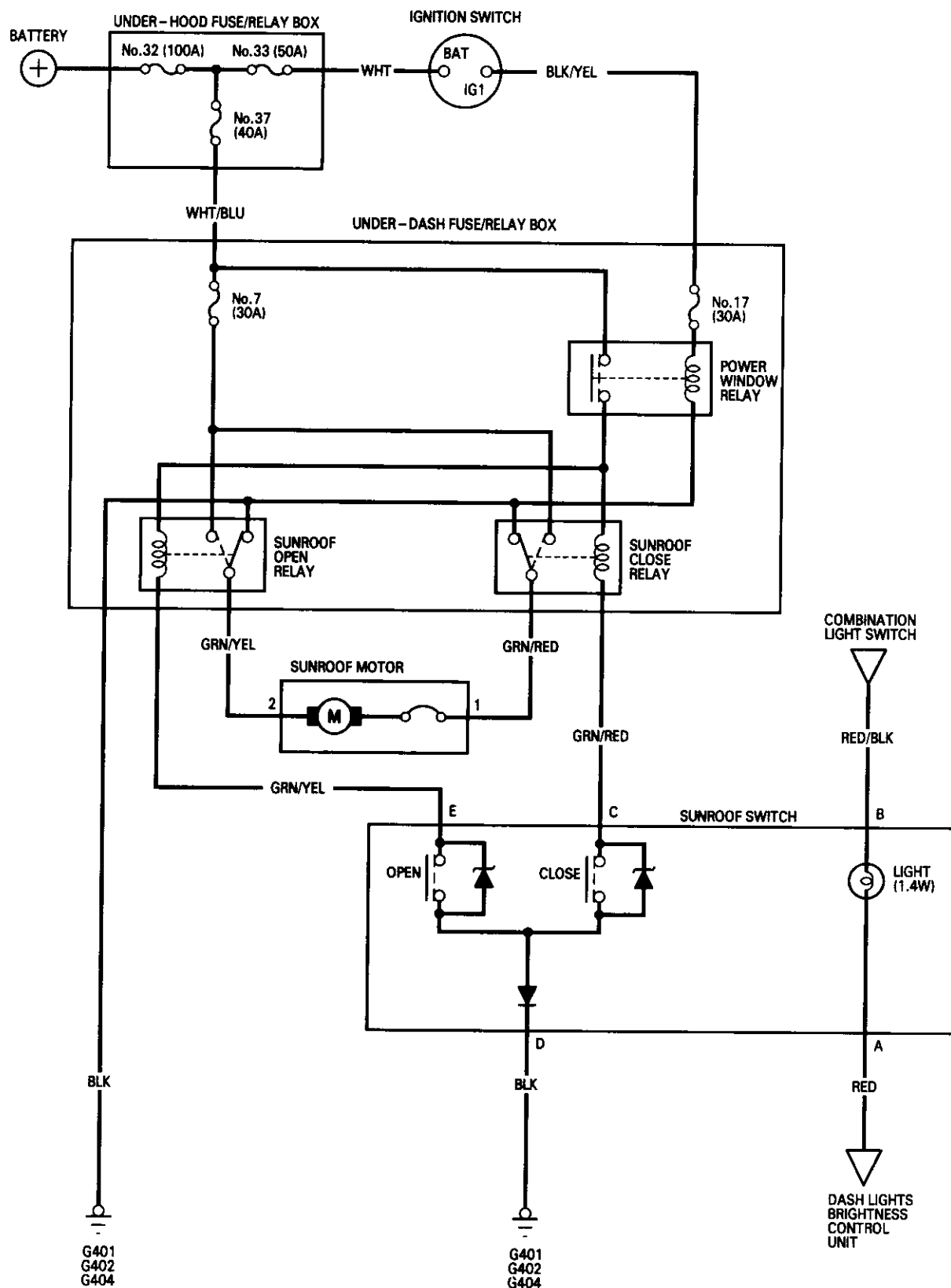



Troubleshooting

NOTE: The numbers in the table show the troubleshooting sequence.

Item to be inspected		Clutch out of adjustment, foreign matter stuck between guide rail and sunroof, or outer cable not attached properly.	Blown No. 37 (40 A) fuse (In the under-hood fuse/relay box)	Blown No. 7 (30 A) fuse (In the under-dash fuse/relay box)	Blown No. 17 (30 A) fuse (In the under-dash fuse/relay box)	Power window relay	Function Test	Open relay	Close relay	Sunroof motor	Sunroof switch	Poor ground	Open circuit, loose or disconnected terminals.
Symptom													
Sunroof does not move, but motor runs.		1											
Sunroof does not move and motor does not run (sunroof can be moved with sunroof wrench).	With either switch.		1	2	3	4	5			6		G401 G402 G404	WHT/BLU, BLK/YEL, GRN/YEL or GRN/RED
	With OPEN switch.							1	2		3		GRN/YEL or GRN/RED
	With CLOSE switch.							2	1		3		GRN/RED or GRN/YEL

Sunroof

Switch Test/Removal

- Carefully pry the switches out of the dashboard, then disconnect the connectors from them.

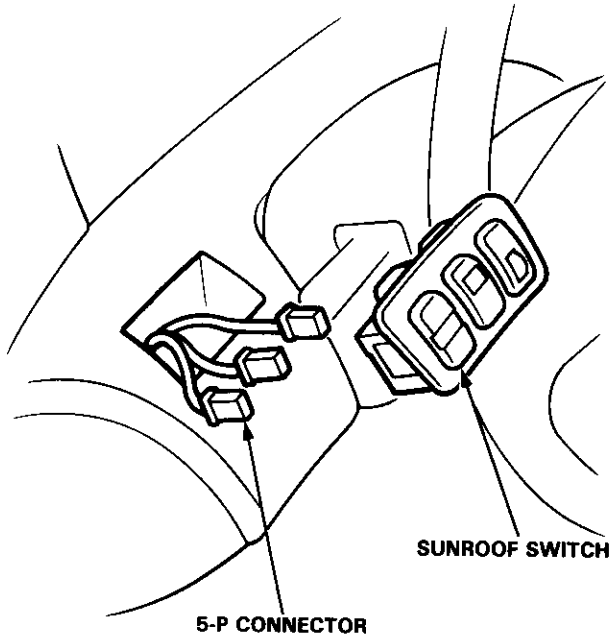

- Remove the sunroof switch from the switch panel.

- Check for continuity between the terminals in each switch position according to the table.

Terminal	A	B	C	E	D
Position					
OFF	○	⊕	○	○	○
OPEN	○	⊕	○	○	○
CLOSE	○	⊕	○	○	○

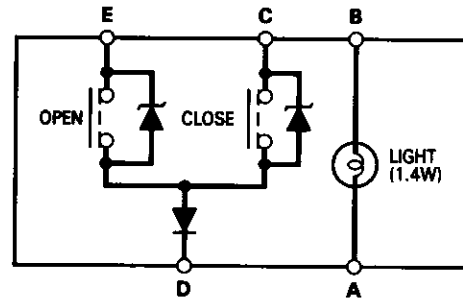
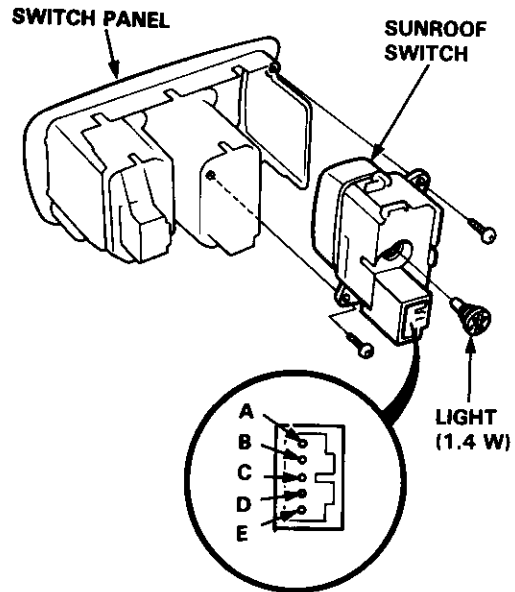



Motor Test

1. Remove the high mount brake light cover.
2. Remove the headliner, then disconnect the 2-P connector from the sunroof motor.
3. Test the motor by connecting power and ground to the 1 and 2 terminals according to the table. The motor should run smoothly.

NOTE: Motor clutch test is in section 20.

OPEN	No. 1 terminal to ground No. 2 terminal to power
CLOSE	No. 1 terminal to power No. 2 terminal to the ground

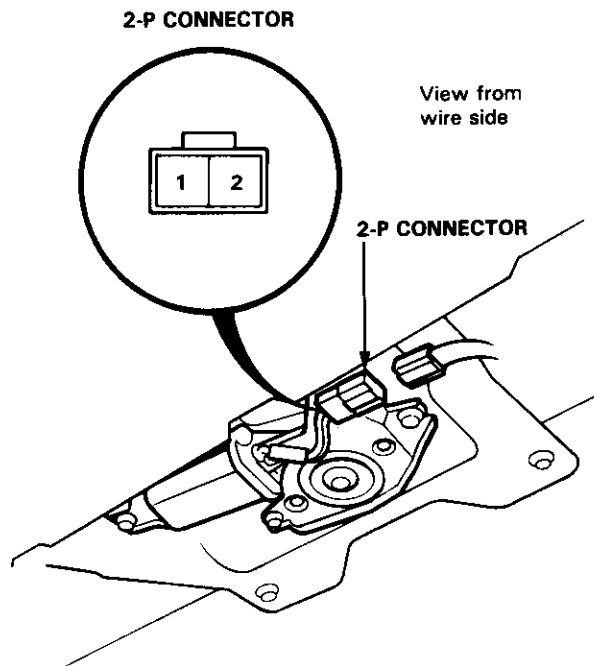

4. If the motor does not run smoothly, replace it.

Power Mirrors

Component Location Index

CAUTION:

- All SRS electrical wiring harnesses are covered with yellow outer insulation.
- When disconnecting the SRS wire harness, install the short connector on the airbag(s) then disconnect the wire harness (see page 23-294).
- Replace the entire affected SRS harness assembly if it has an open circuit or damaged wiring.

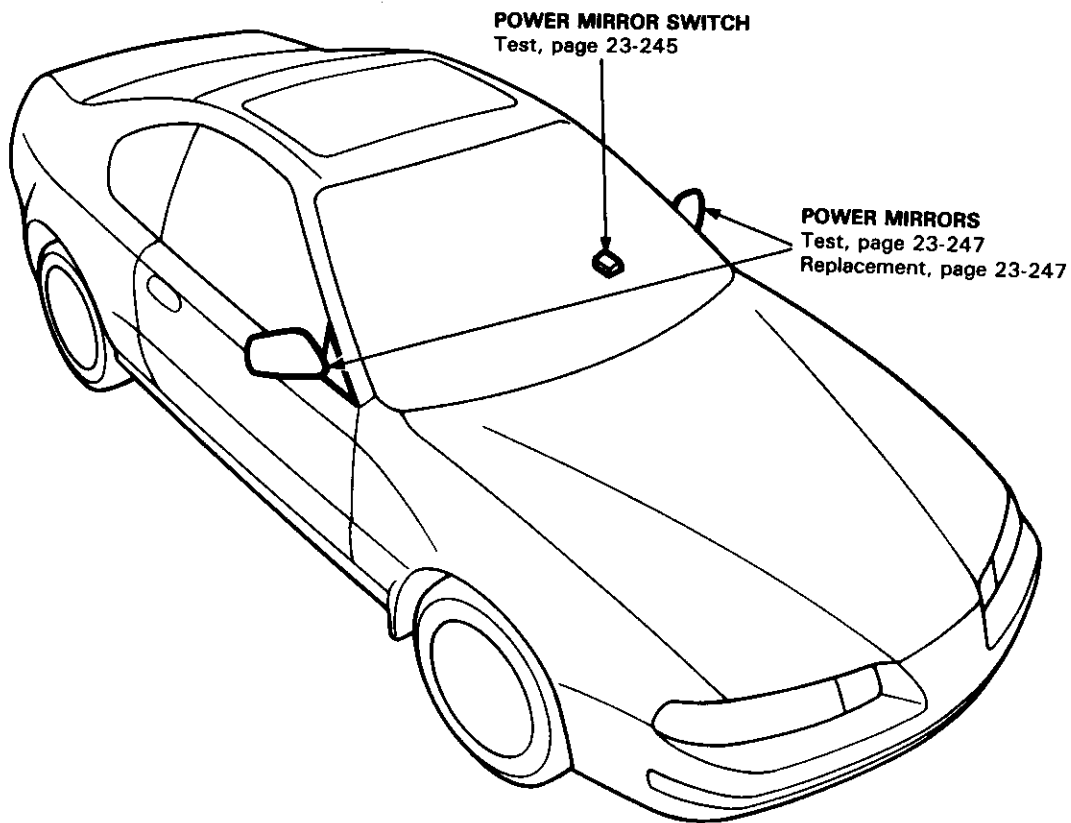
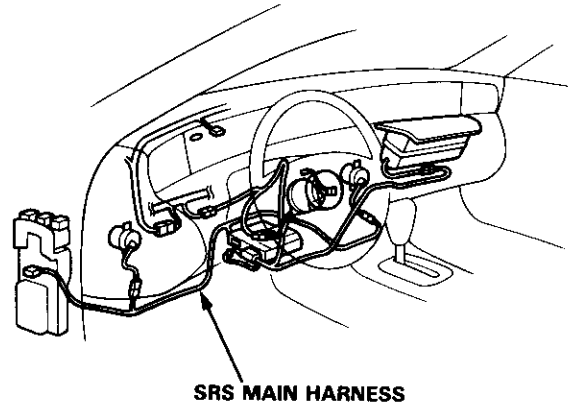



Circuit Diagram (USA)

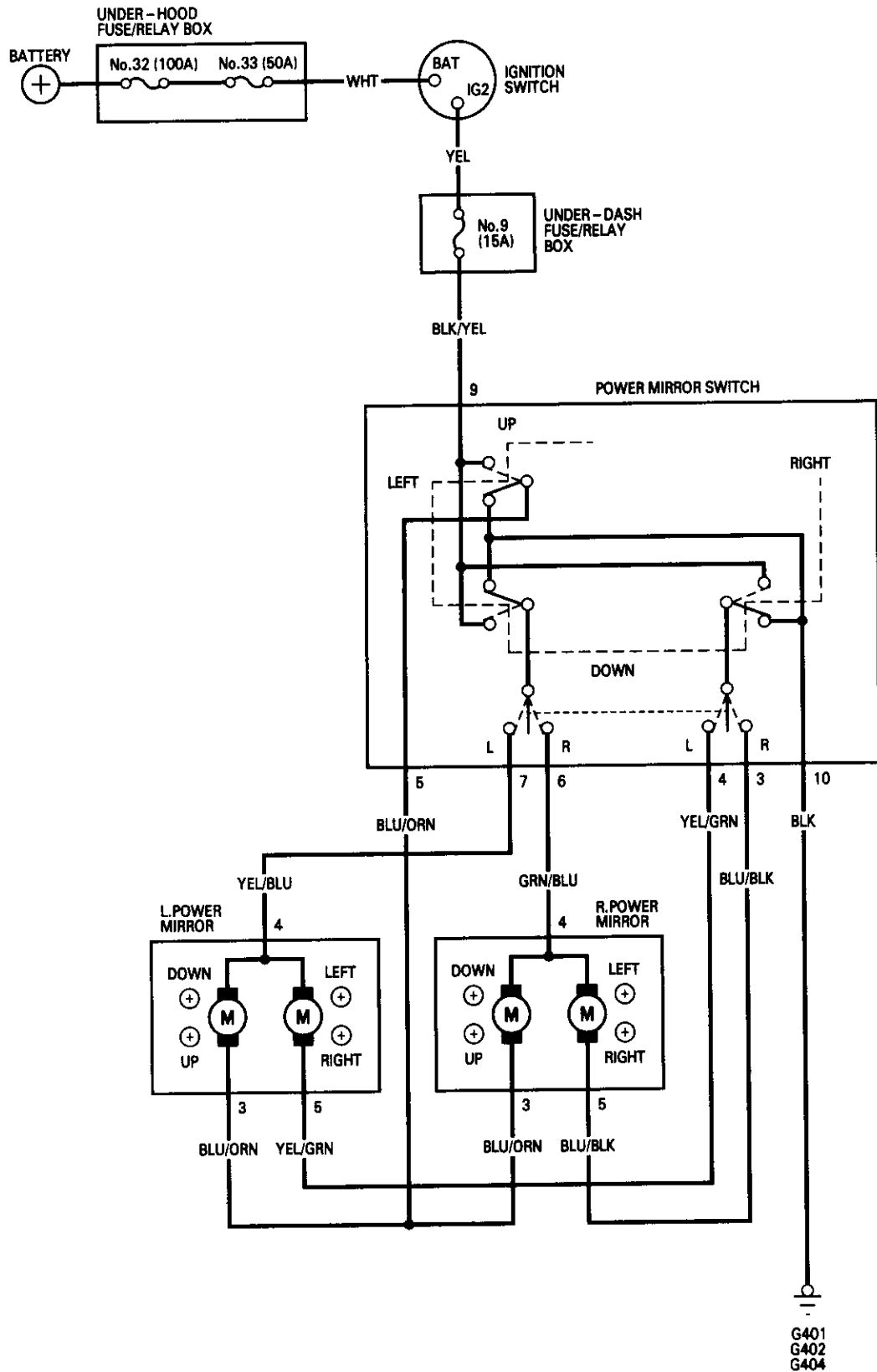

Power Mirrors

Circuit Diagram (Canada)

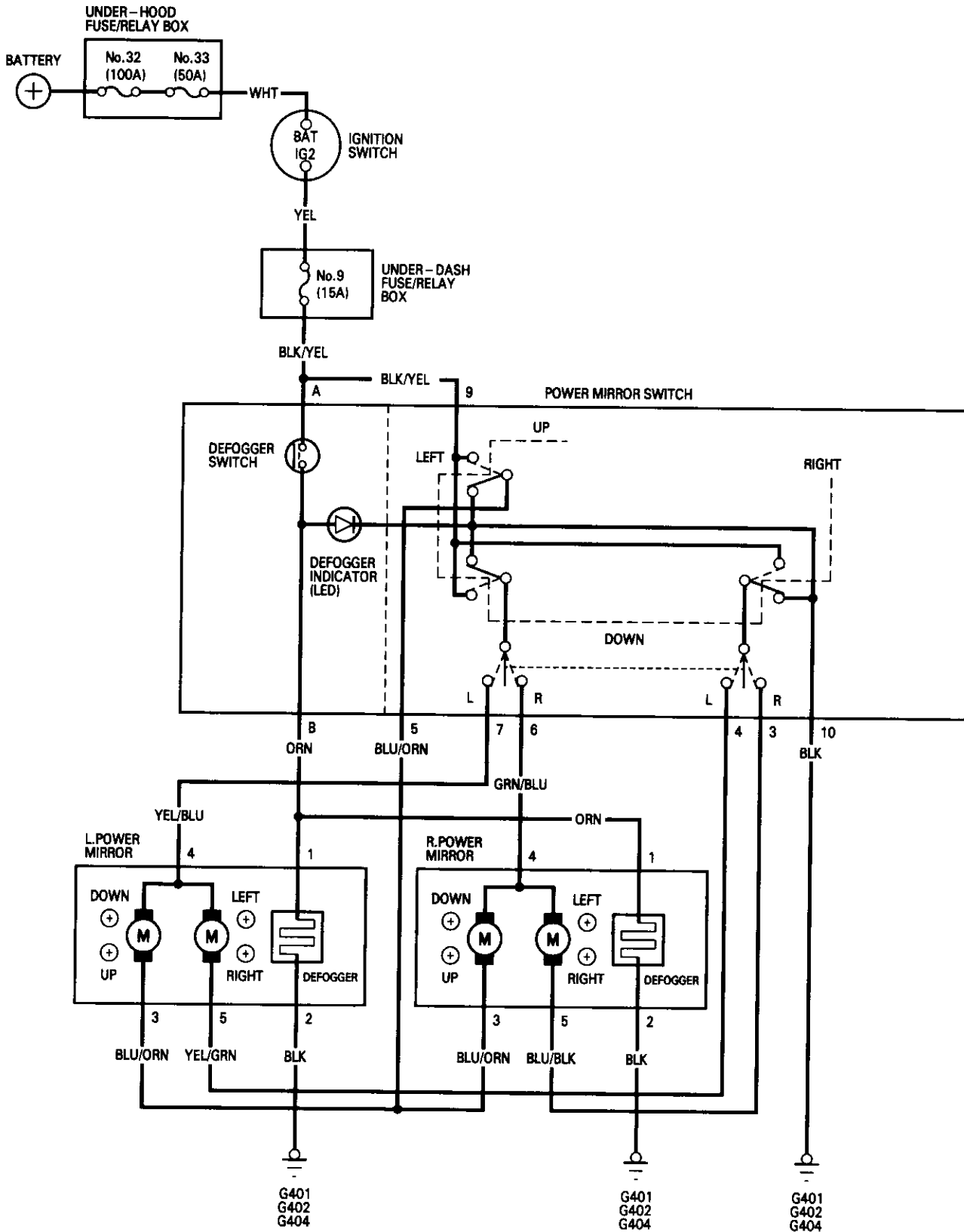



Switch Test

1. Remove the switch as described under "FUNCTION TEST".
2. Check for continuity between the terminals in each switch position according to the table.

Mirror Switch

Terminal	9	10	5	4	7	3	6
Position							
R	OFF	○	○	○	○	○	○
	UP	○	○	○			○
	DOWN	○	○	○			○
	LEFT	○	○	○	○	○	○
	RIGHT	○	○	○	○	○	○
L	OFF	○	○	○	○	○	○
	UP	○	○	○			
	DOWN	○	○	○			
	LEFT	○	○	○	○	○	○
	RIGHT	○	○	○	○	○	○

Defogger Switch(Canada)

Terminal	A	B		5	10
Position					
ON	○	○	○	○	○
OFF		○	○	○	○

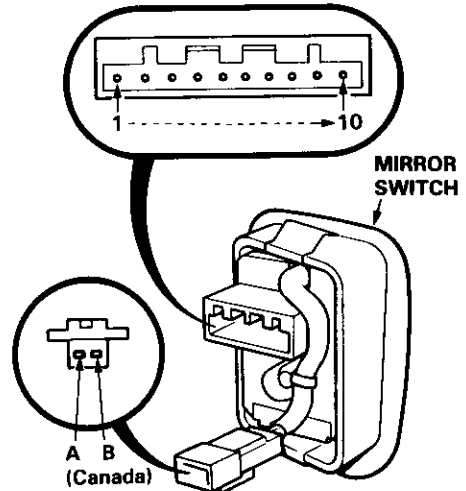

USA :

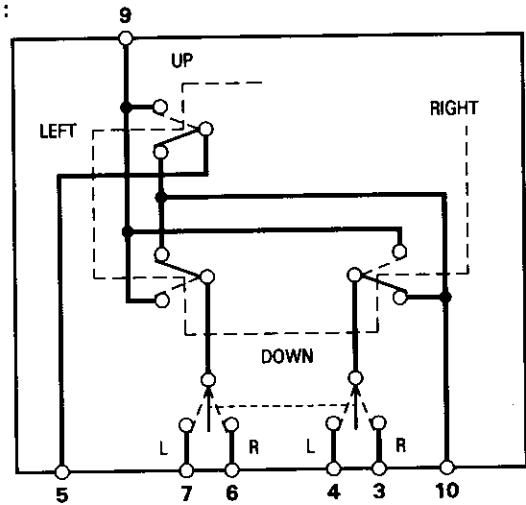

Canada :

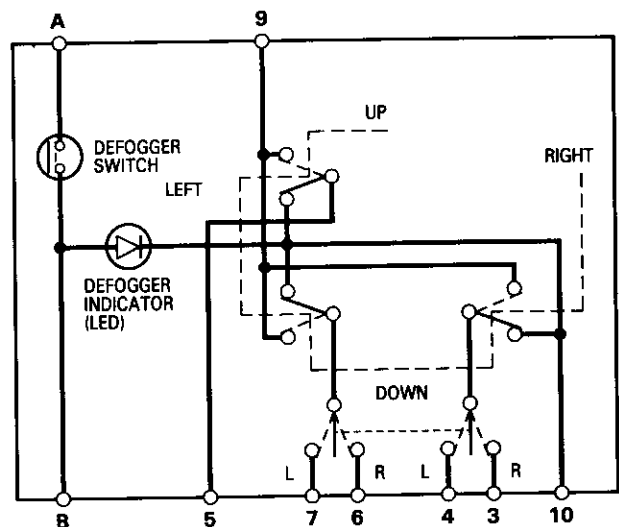

Power Mirrors

Function Test

1. Carefully pry the switch out of the door panel.
2. Disconnect the connectors from the switch.

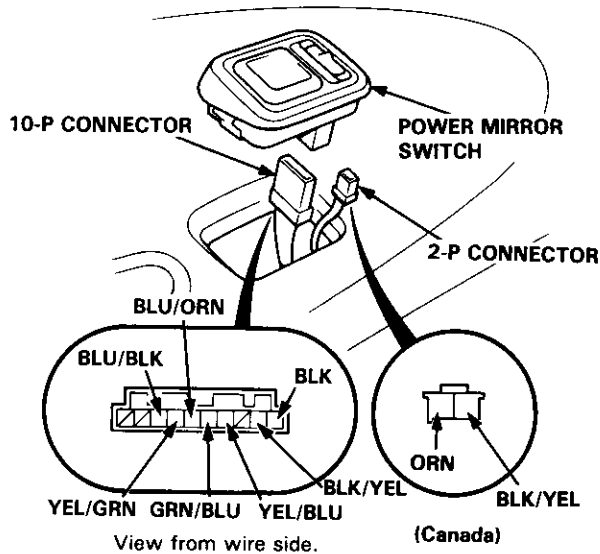

Mirror Test

One or both inoperative:

1. Check for voltage between the BLK/YEL terminal and body ground with the ignition switch ON. There should be battery voltage.
 - If there is no voltage, check for:
 - Blown No. 9 (15 A) fuse in the under-dash fuse/relay box.
 - An open in the BLK/YEL wire.
 - If there is battery voltage, go to step 2.
2. Check for continuity between the BLK terminal and body ground. There should be continuity.
 - If there is no continuity, check for:
 - An open in the BLK wire.
 - Poor ground (G401, G402, G404).

Left mirror inoperative:

Connect the BLK/YEL terminal of the 10-P connector to the YEL/BLU terminal, and the BLU/ORN (or YEL/GRN) terminal to body ground with jumper wires.

The left mirror should tilt down (or swing left) with the ignition switch ON.

- If the mirror does not tilt down (or does not swing left), remove the left door panel and check for an open in the BLU/ORN (or YEL/GRN) wire between the left door mirror and the switch. If the wire is OK, check the left door mirror motor.

- If the mirror neither tilts down nor swings left, repair the YEL/BLU wire.
- If the mirror works properly, check the mirror switch.

Right mirror inoperative:

Connect the BLK/YEL terminal of the 10-P connector to the GRN/BLU terminal and the BLU/ORN (or BLU/BLK) terminal to body ground with jumper wires.

The right mirror should tilt down (or swing left) with the ignition switch ON.

- If the mirror does not tilt down (or does not swing left), remove the right door panel and check for an open in the BLU/ORN (or BLU/BLK) wire between the right door mirror and the switch. If the wire is OK, check the right door mirror motor.
- If the mirror neither tilts down nor swings left, repair the GRN/BLU wire.
- If the mirror works properly, check the mirror switch.

Defogger test (Canada)

NOTE: Check the No. 9 (15 A) fuse in the under-dash fuse/relay box before testing.

1. Check for voltage between the BLK/YEL terminal of the 2-P connector and body ground with the ignition switch ON. There should be battery voltage.
 - If there is no voltage, check for an open in the BLK/YEL wire between the under-dash fuse/relay box and the defogger switch.
 - If there is battery voltage, go to step 2.
2. Connect the BLK/YEL terminal of the 2-P connector to the ORN terminal with a jumper wire. Both the right and left mirrors should gradually warm up with the ignition switch ON.
 - If neither warms up, repair the ORN wire.
 - If only one fails to warm up, check its mirror defogger element (see page 23-247).
 - If both warm up, check the switch.



Power Mirror Motor Test

1. Carefully pry out the window corner panel with a flat tip screwdriver.
2. Remove the door panel.
3. Disconnect the 3-P or 6-P connector from the mirror.

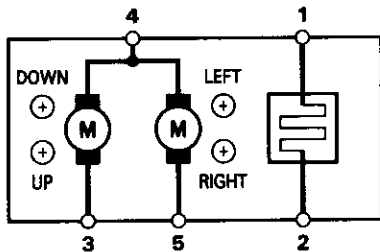
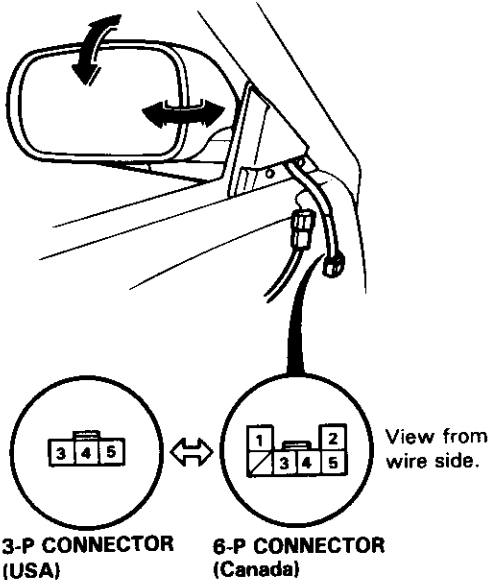

4. Test actuator operation:

TILT UP	Connect battery power to the No. 3 terminal and ground to the No. 4 terminal.
TILT DOWN	Connect battery power to the No. 4 terminal and ground to the No. 3 terminal.
SWING LEFT	Connect battery power to the No. 4 terminal and ground to the No. 5 terminal.
SWING RIGHT	Connect battery power to the No. 5 terminal and ground to the No. 4 terminal.

5. Check for continuity between the No. 1 and No. 2 terminals (RX 10³ scale). There should be continuity.

Power Mirror Replacement

NOTE: Before removing the mirror, lower the window fully.

1. Carefully pry out the window corner panel with a flat tip screwdriver.
2. Remove the door panel.
3. Disconnect the 3-P or 6-P connector from the mirror.
4. While holding the mirror with one hand, remove the three mounting screws with the other.

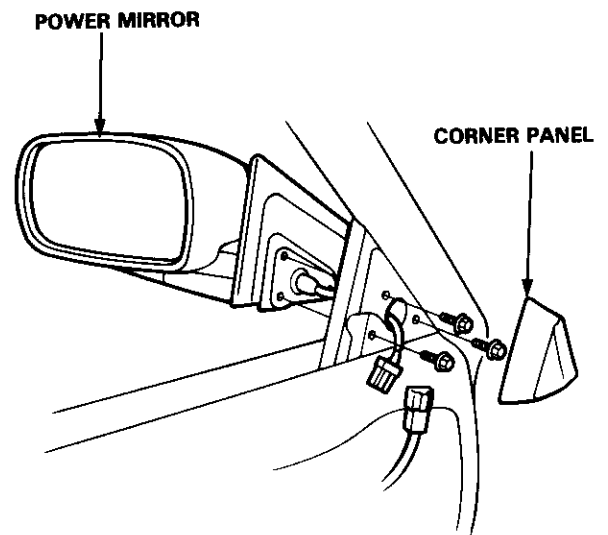

Power Windows

Component Location Index

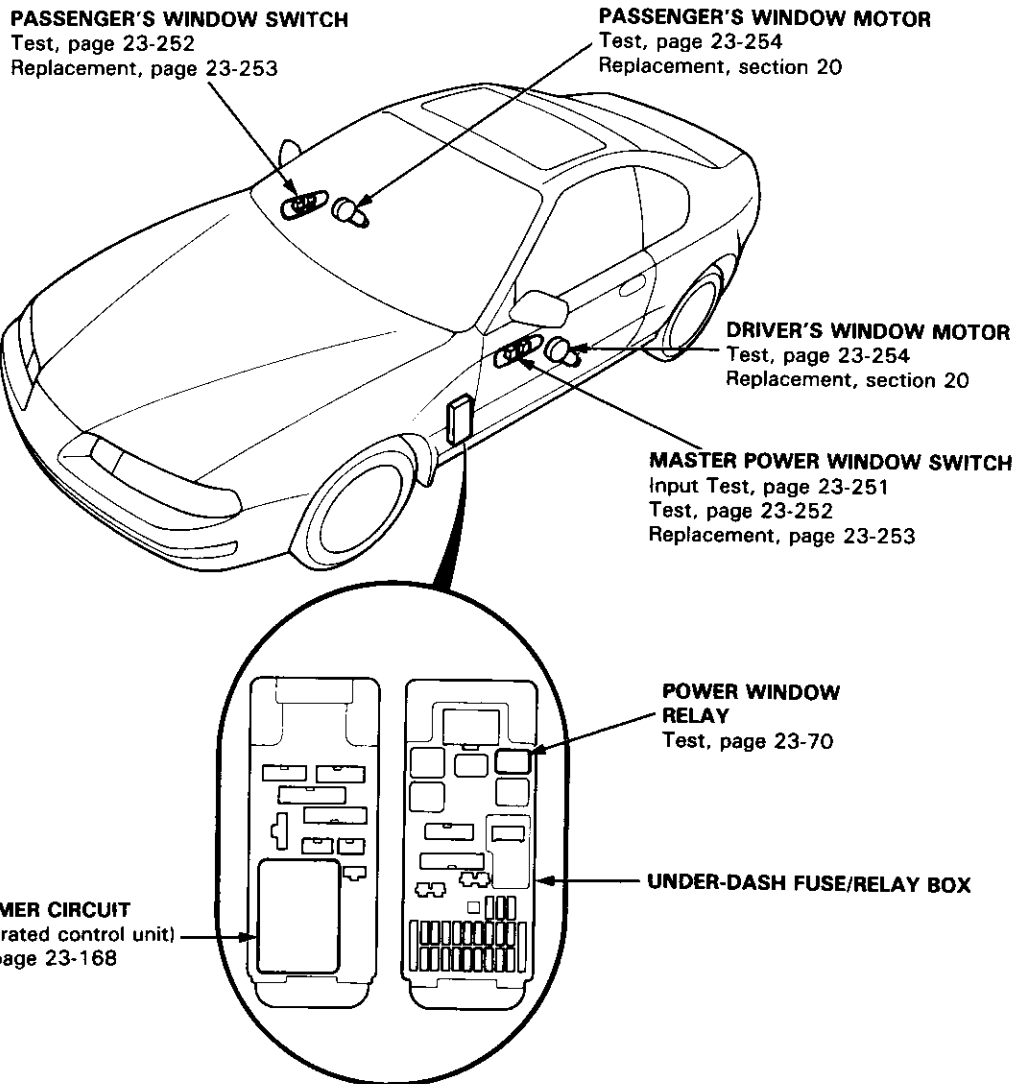

Description

Power Window Key-off Timer Operation:

The power windows can still be operated for about 10 minutes after the ignition switch is turned from the "II" to the "I" or "O" position as long as neither door has been opened. This provides a convenience to parked occupants.



Circuit Diagram

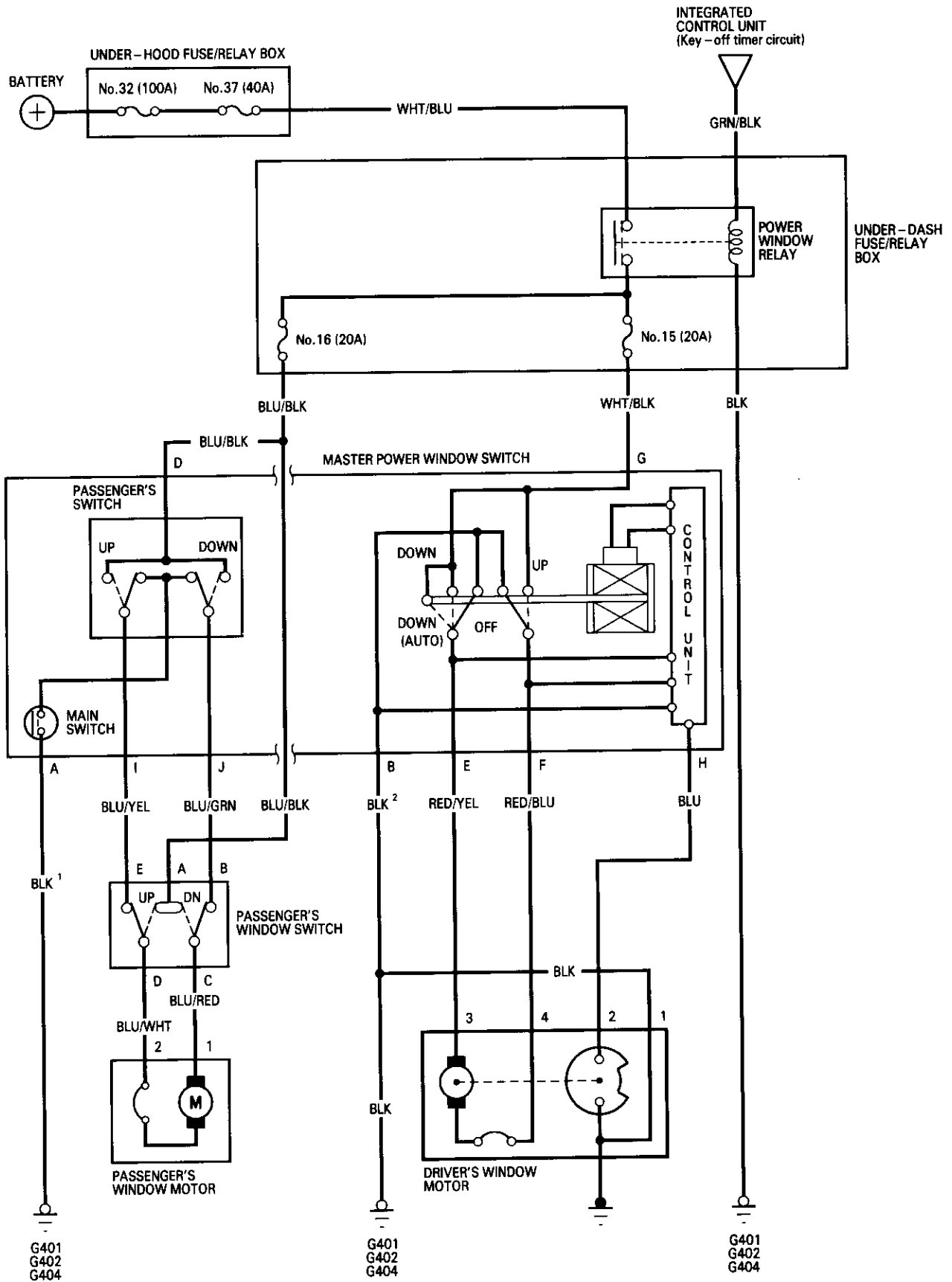

Power Windows

Troubleshooting

NOTE: The numbers in the table show the troubleshooting sequence.

Symptom	Blown No. 37 (40 A) fuse (In the under-dash fuse/relay box)		Power window relay		In the under-dash fuse/relay box		Driver's window switch	Passenger's window switch	Driver's window motor	Pulser (in driver's motor)	Passenger's window motor	Window regulator	Master power window switch input	Door window switches	Key-off timer circuit (In the integrated control unit)	Poor ground	Open circuit, loose or disconnected terminals
	1	2	Blown No. 15 (20 A) fuse	Blown No. 16 (20 A) fuse													
Neither window works.	1	2													3	G401 G402 G404	GRN/BLK
Driver's window does not work.			1					2				3	4				WHT/BLK
Driver's window does not work in AUTO.				1					2				3				BLU
Passenger's window does not work.				1	2	3				4	5						BLU/BLK
One or both windows do not work within 10 minutes after the ignition switch is OFF.	1													2	3		



Master Power Window Switch Input Test

NOTE: The control unit is built into the master power window switch, and only controls the driver's window.

1. Remove the driver's door handle panel and disconnect the 10-P and 3-P connectors from it.
2. Inspect the connector terminals to be sure they are all making good contact.
 - If the terminals are bent, loose, or corroded, repair them as necessary, and recheck the system.
 - If the terminals look OK, make the following input tests at the 10-P connector.
 - If a test indicates a problem, find and correct the cause, then recheck the system.
 - If all input tests prove OK, the control unit must be faulty; replace the master power window switch.

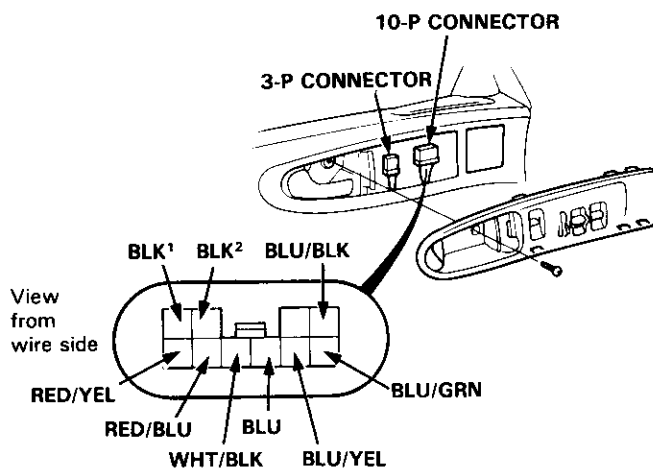

No.	Terminal	Test condition	Test: Desired result	Possible cause if result is not obtained
1	BLK ¹	Under all conditions.	Check for continuity to ground: There should be continuity.	<ul style="list-style-type: none"> • Poor ground (G401, G402, G404). • An open in the wire.
2	WHT/BLK	Ignition switch ON.	Check for voltage to ground: There should be battery voltage.	<ul style="list-style-type: none"> • Blown No. 15 or 16 (20 A) fuse. (In the under-dash fuse/relay box) • Faulty power window relay. • An open in the wire.
	BLU/BLK			
3	RED/BLU and RED/YEL	Connect the WHT/BLK terminal to the RED/BLU terminal, and the RED/YEL terminal to the BLK ¹ terminal, then turn the ignition switch ON.	Check the driver's window motor: It should run.	<ul style="list-style-type: none"> • Faulty driver's window motor. • An open in the wire.
4	BLU/YEL and BLU/GRN	Connect the BLU/BLK terminal to the BLU/GRN terminal, and the BLU/YEL terminal to the BLK terminal, then turn the ignition switch ON.	Check the passenger's window motor: It should run.	<ul style="list-style-type: none"> • Faulty passenger's window motor. • Faulty passenger's window switch. • An open in the wire.
5	BLU and BLK ²	Connect the WHT/BLK terminal to the RED/YEL terminal, and the BLK ² terminal to the RED/BLU terminal, then turn the ignition switch ON.	Connect an analog ohmmeter to the BLU and BLK ² terminals: The meter needle should move back and forth as the driver's window motor runs.	<ul style="list-style-type: none"> • Faulty pulser. • Faulty driver's window motor. • An open in the wire.

Power Windows

Master Power Window Switch Test

1. Remove the driver's door handle panel and disconnect the 10-P and 3-P connectors from it.
2. Check for continuity between the terminals in each switch position according to the table.

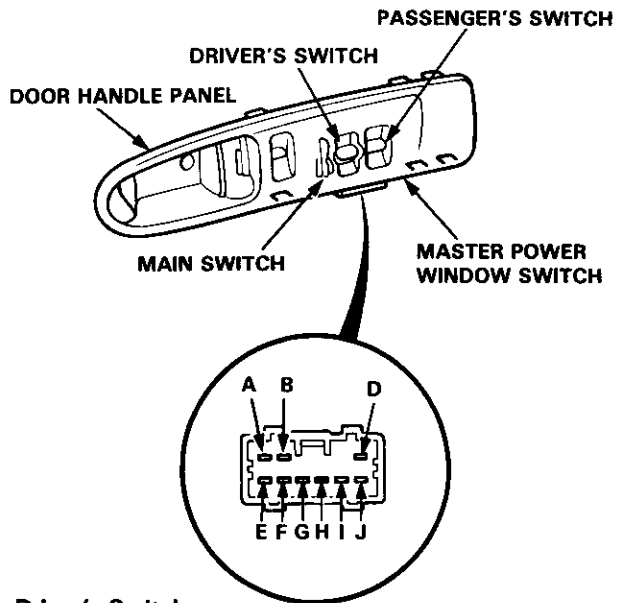

Driver's Switch

Terminal	B	E	F	G
Position				
OFF	○	○	○	
UP			○	○
DOWN		○		○
DOWN (AUTO)		○		○

Passenger's Switch

Terminal	A	D	I	J
Position				
OFF	Main switch ON		○	○
	Main switch OFF		○	○
UP	ON	○	○	
	OFF	○	○	
DOWN	ON	○		○
	OFF	○		○

Passenger's Window Switch Test

1. Carefully remove the passenger's door handle panel from the door, then disconnect the 5-P connector.
2. Check for continuity between the terminals in each switch position according to the table.

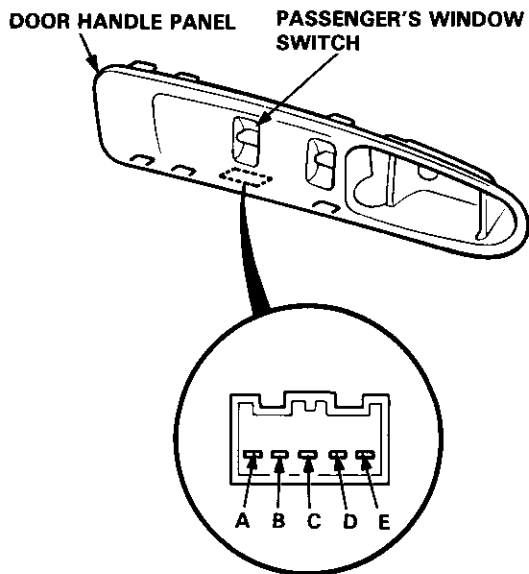

Terminal	A	B	C	D	E
Position					
UP	○			○	
OFF		○	○	○	○
DOWN	○		○		



Switch Replacement

Master power window switch:

1. Remove the mounting screw and pry the driver's door handle panel out of the door panel.
2. Disconnect the 10-P and 3-P connectors from it.

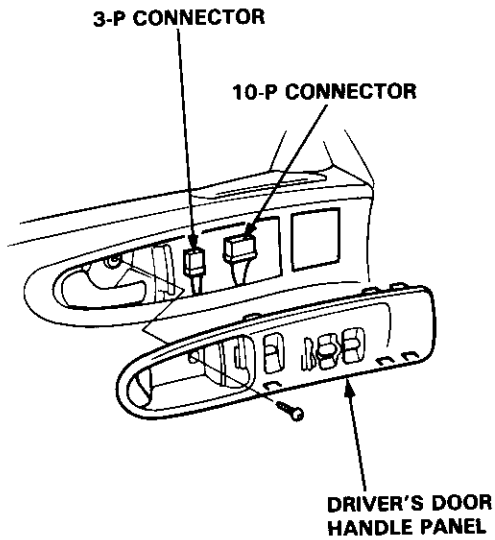

3. Remove the master power window switch from the door handle panel by removing the four mounting screws.

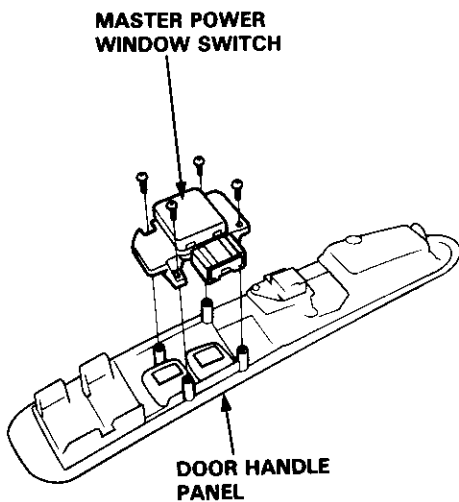

Passenger's window switch:

1. Remove the mounting screw and pry the passenger's door handle panel out of the door panel.
2. Disconnect the 5-P and 3-P connectors from it.

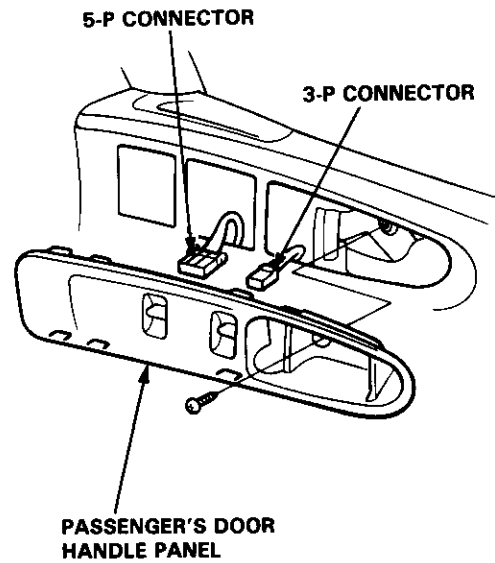

3. Remove the passenger's window switch from the door handle panel by removing the two mounting screws.

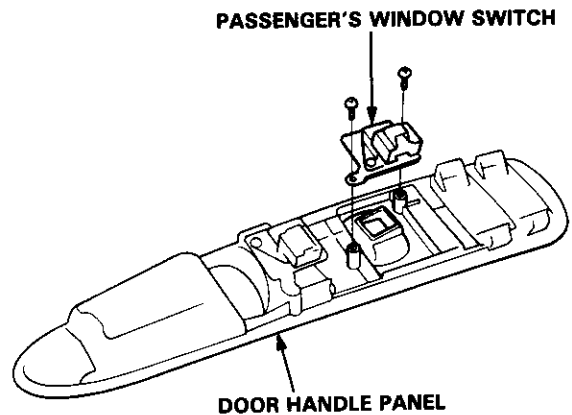

Power Windows

Driver's Window Motor Test

Motor Test:

1. Remove the door panel (see section 20).
2. Disconnect the 4-P connector from the motor.
3. Test motor operation by connecting battery power to the No. 3 terminal and grounding the No. 4 terminal. Test the motor in each direction by switching the leads.
4. If the motor does not run, replace it.

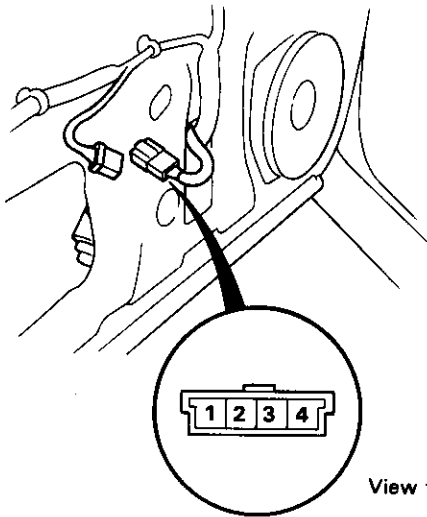

View from wire side

Pulser Test:

Connect the test leads of an analog ohmmeter to the No. 1 and No. 2 terminals. Run the motor by connecting power and ground to the No. 3 and No. 4 terminals. The ohmmeter needle should move back and forth as the motor runs.

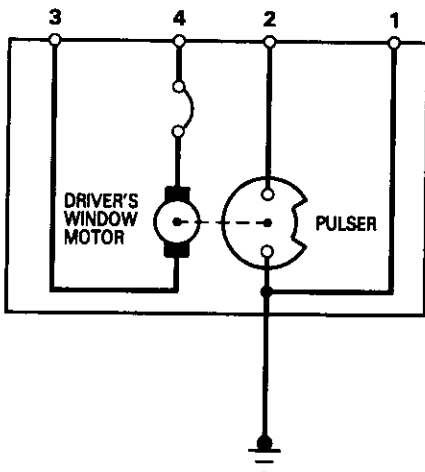

Passenger's Window Motor Test

1. Remove the door panel (see section 20).
2. Disconnect the 2-P connector from the motor.
3. Test motor operation by connecting power and ground to the No. 1 and No. 2 terminals. Test the motor in each direction by switching the leads.
4. If the motor does not run, replace it.

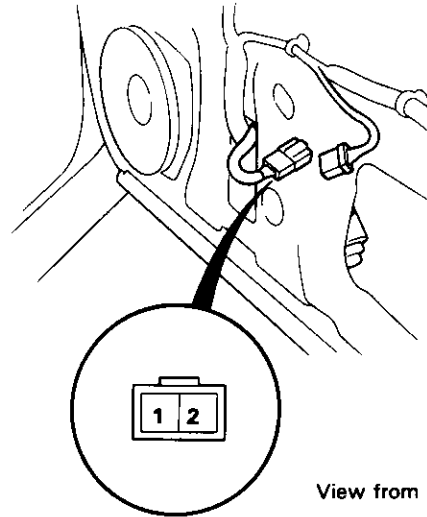

View from wire side

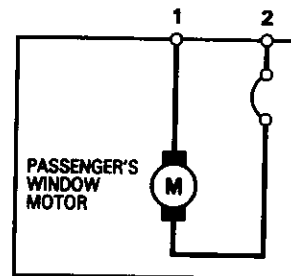



Power Door Locks

Component Location Index

CAUTION:

- All SRS electrical wiring harnesses are covered with yellow outer insulation.
- Before disconnecting the SRS wire harness, install the short connector on the airbag(s) then disconnect the wire harness (see page 23-294).
- Replace the entire affected SRS harness assembly if it has an open circuit or damaged wiring.

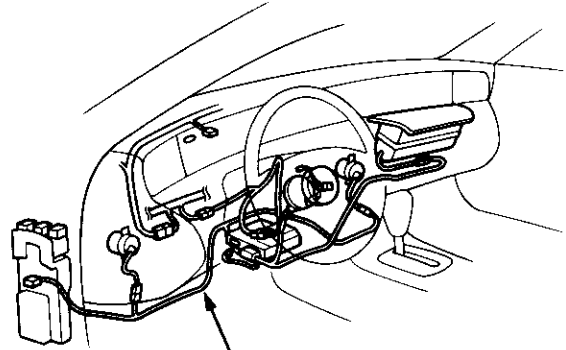

SRS MAIN HARNESS

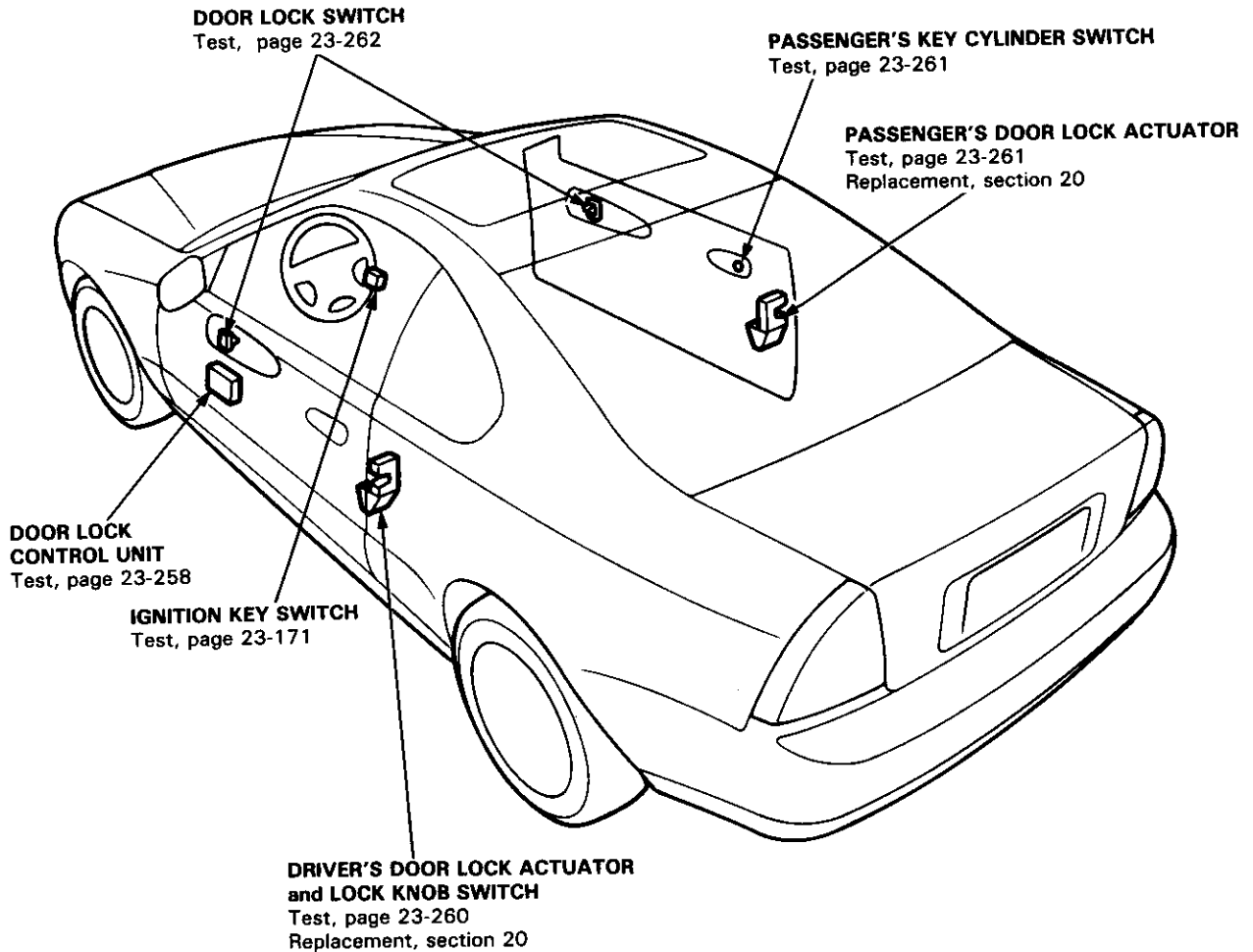

Power Door Locks

Circuit Diagram

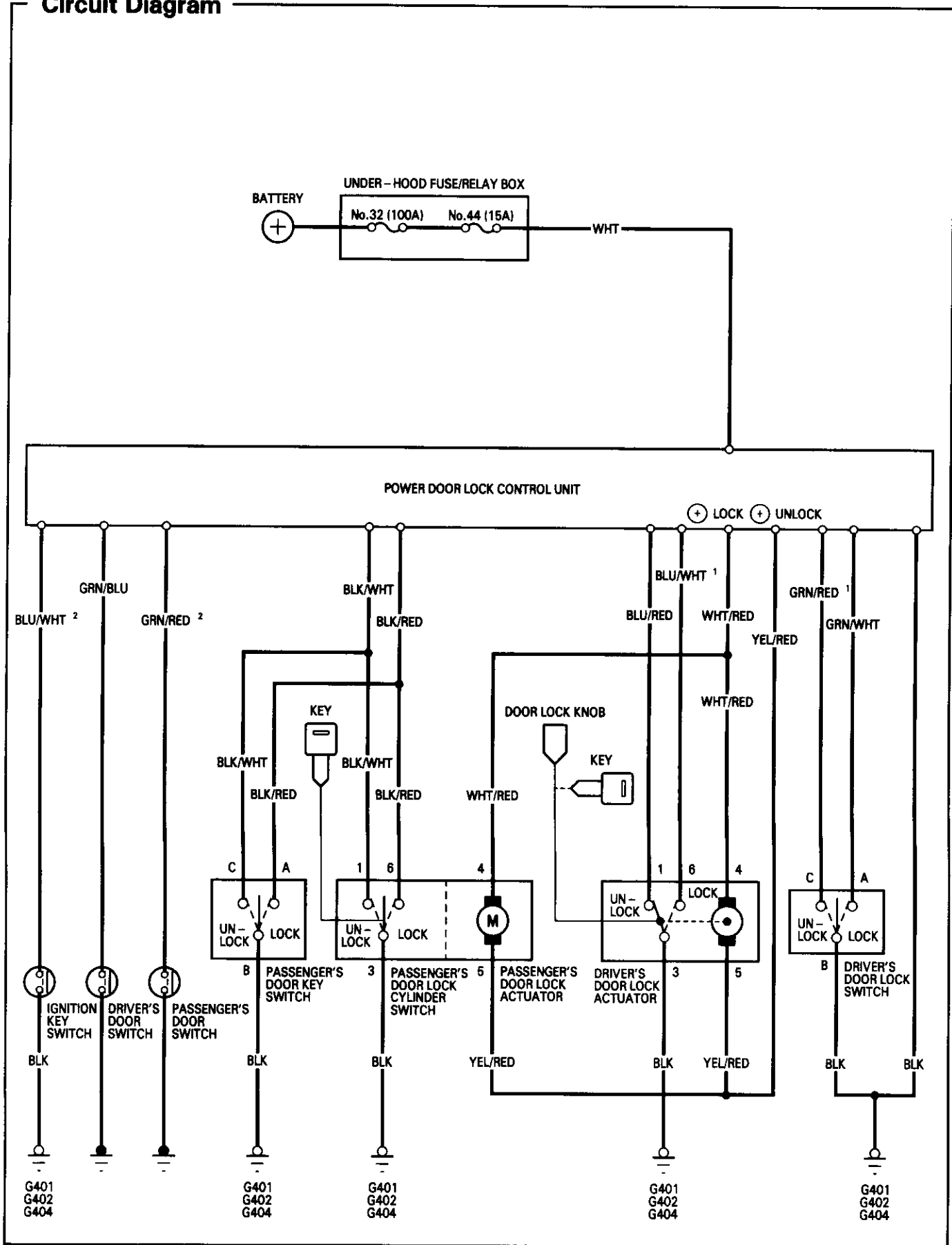



Troubleshooting

NOTE: The numbers in the table show the troubleshooting sequence.

Item to be inspected		Blown No. 44 (15 A) fuse (In the under-hood fuse/relay box)	Disconnected or obstructed door lock rod/linkage	Driver's door lock knob switch (In the driver's door lock actuator)	Ignition key switch	Driver's door switch	Passenger's door switch	Driver's door lock actuator	Passenger's door lock actuator	Driver's door lock switch	Passenger's door lock switch	Control unit input	Passenger's door key cylinder	Poor ground	Open circuit, loose or disconnected terminals
Power door lock system doesn't work at all.		1										2		G401 G402 G404	WHT
Doors don't lock or unlock with the driver's power door lock switch.	Both doors									1		2		G401 G402 G404	GRN/WHT or GRN/RED ¹
	One door		1					2				3			YEL/RED or WHT/RED
Doors don't lock or unlock with the passenger's power door lock switch.	Both doors										1	2		G401 G402 G404	BLK/WHT or BLK/RED
	One door		1					2				3			YEL/RED or WHT/RED
Doors don't lock with the driver's door lock knob. (Ignition key not inserted and doors closed.)	Both doors			1								2		G401 G402 G404	BLU/RED or BLU/WHT ¹
	One door		1					2				3			YEL/RED or WHT/RED
Doors don't lock or unlock with the passenger's door key cylinder switch.	Both doors											2	1	G401 G402 G404	BLK/RED or BLK/WHT
	One door		1					2				3			YEL/RED or WHT/RED
Doors will lock when the key is still in the ignition switch and the driver's door is open.					1	2	3					4		G401 G402 G404	BLU/WHT ² GRN/RED ² or GRN/BLU

Power Door Locks

Control Unit Input Test

1. Remove the driver's door panel (see section 20) and disconnect the 18-P connector from the power door lock control unit.
2. Inspect the connector terminals to be sure they are all making good contact.
 - If the terminals are bent, loose, or corroded, repair them as necessary, and recheck the system.
 - If the terminals look OK, make the following input test at the connector terminals.
 - If a test indicates a problem, find and correct the cause, then recheck the system.
 - If all input tests prove OK, the control unit must be faulty; replace it.

NOTE: Different wires with the same color have been given a number suffix to distinguish them (for example, GRN/RED¹ and GRN/RED² are not the same).

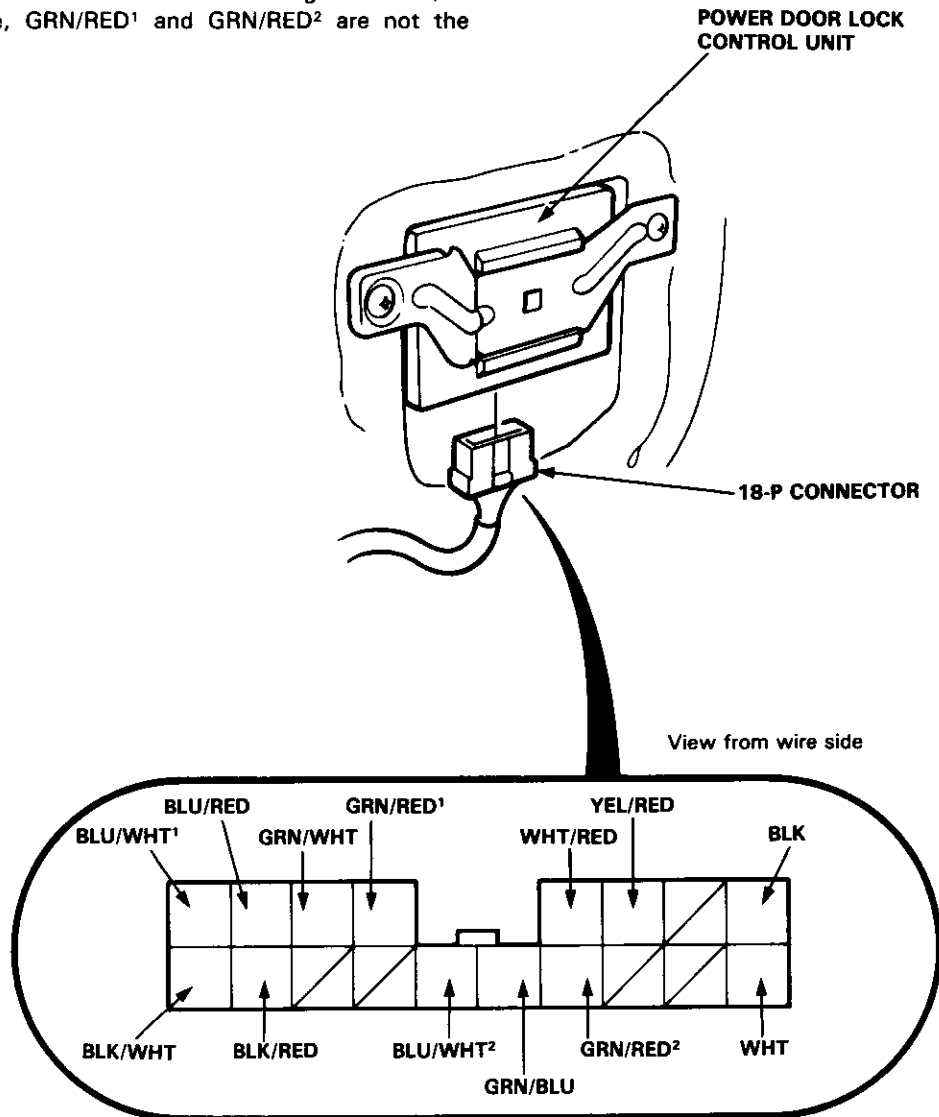



Disconnect the 18-P connector from the control unit.

No.	Wire	Test condition	Test: Desired result	Possible cause if result is not obtained
1	BLK	Under all conditions.	Check for continuity to ground: There should be continuity.	<ul style="list-style-type: none"> • Poor ground (G401, G402, G404). • An open in the wire.
2	WHT/RED and YEL/RED	Connect the YEL/RED terminal to the WHT terminal, and the WHT/RED terminal to the BLK terminal momentarily.	Check door lock operation: All doors should unlock.	<ul style="list-style-type: none"> • Faulty actuator. • An open in the wire.
		Connect the WHT/RED terminal to the WHT terminal, and the YEL/RED terminal to the BLK terminal momentarily.	Check door lock operation: All doors should lock.	

Reconnect the 18-P connector to the control unit.

No.	Wire	Test condition	Test: Desired result	Possible cause if result is not obtained
3	WHT	Under all conditions.	Check for voltage to ground: There should be battery voltage.	<ul style="list-style-type: none"> • Blown No. 44 (15 A) fuse. (In the under-hood fuse/relay box) • An open in the wire.
4	GRN/WHT	Driver's door lock switch in LOCK.	Check for voltage to ground: There should be 1 V or less.	<ul style="list-style-type: none"> • Faulty driver's door lock switch. • Poor ground (G401, G402, G404). • An open in the wire.
	GRN/RED ¹	Driver's door lock switch in UNLOCK.		
5	BLK/RED	Passenger's door lock switch in LOCK.	Check for voltage to ground: There should be 1 V or less.	<ul style="list-style-type: none"> • Faulty passenger's door lock switch. • Poor ground (G401, G402, G404). • An open in the wire.
	BLK/WHT	Passenger's door lock switch in UNLOCK.		
6	BLU/WHT ¹	Driver's door lock knob in LOCK.	Check for voltage to ground: There should be 1 V or less.	<ul style="list-style-type: none"> • Faulty driver's door lock actuator. • Poor ground (G401, G402, G404). • An open in the wire.
	BLU/RED	Driver's door lock knob in UNLOCK.		
7	GRN/BLU	Driver's door open.	Check for voltage to ground: There should be 1 V or less. NOTE: Before testing, remove No. 46 (15 A) fuse in the under-hood fuse/relay box.	<ul style="list-style-type: none"> • Faulty door switch. • Poor ground. • An open in the wire.
	GRN/RED ²	Passenger's door open.		
8	BLU/WHT ²	Ignition key is in the ignition switch.	Check for voltage to ground: There should be 1 V or less.	<ul style="list-style-type: none"> • Faulty ignition key switch. • Poor ground (G401, G402, G404). • An open in the wire.
9	BLK/RED	Passenger's door key cylinder in LOCK.	Check for voltage to ground: There should be 1 V or less as the switch is turned.	<ul style="list-style-type: none"> • Faulty passenger's door cylinder. • Poor ground (G401, G402, G404). • An open in the wire.
	BLK/WHT	Passenger's door key cylinder in UNLOCK.		

CAUTION: To prevent damage to the motor, apply battery voltage only momentarily.

Power Door Locks

Driver's Door Lock Actuator Test

1. Remove the door panel (see section 20).
2. Disconnect the 6-P connector from the actuator.

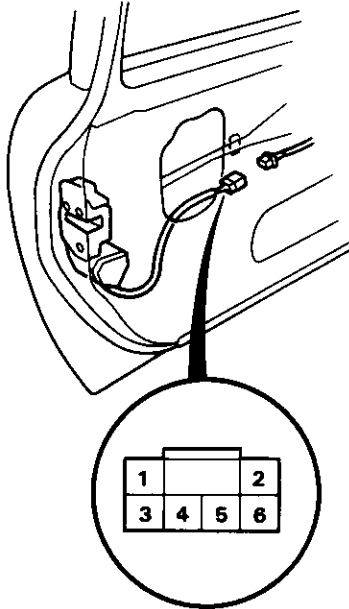

View from wire side

3. Test actuator operation:

LOCK: With battery power connected to the No. 4 terminal, ground the No. 5 terminal momentarily.

UNLOCK: With battery power connected to the No. 5 terminal, ground the No. 4 terminal momentarily.

CAUTION: To prevent damage to the motor, only connect power momentarily.

4. If the actuator does not work properly, replace it.

5. Check for continuity between the terminals in each switch position according to the table.

Terminal Position	1	3	6
LOCK		○—○	○—○
UNLOCK	○—○	○—○	

DOOR LOCK KNOB

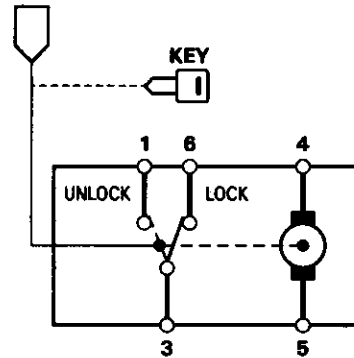



Passenger's Door Lock Actuator Test

1. Remove the door panel (see section 20).
2. Disconnect the 6-P connector from the actuator.

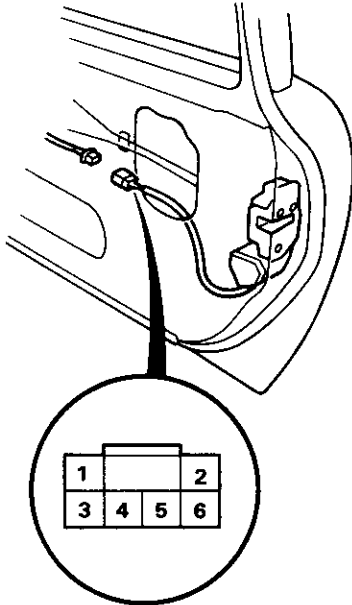

6-P CONNECTOR
View from wire side

3. Test actuator operation:

LOCK: With battery power connected to the No. 4 terminal, ground the No. 5 terminal momentarily.

UNLOCK: With battery power connected to the No. 5 terminal, ground the No. 4 terminal momentarily.

CAUTION: To prevent damage to the motor, connect power only momentarily.

4. If the actuator does not work properly, replace it.

Key Cylinder Switch Test

1. Remove the door panel (see section 20).
2. Disconnect the 6-P connector from the actuator.

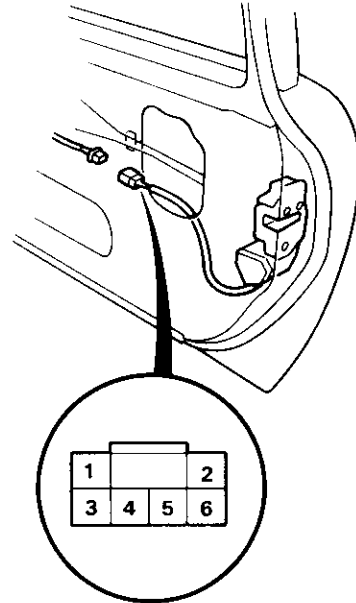

6-P CONNECTOR
View from wire side

3. Check for continuity between the terminals in each switch position according to the table.

Terminal	1	3	6
Position			
LOCK		○ — ○	
UNLOCK	○ — ○		

Power Door Locks

Door Lock Switch Test

1. Remove the door handle panel.

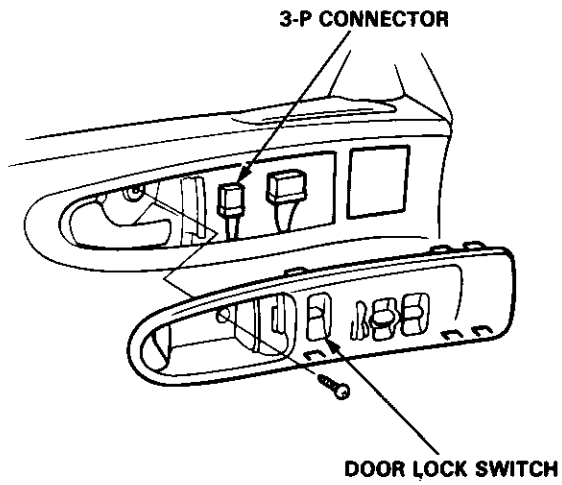

2. Disconnect the 3-P connector from the switch.
3. Check for continuity between the terminals in each switch position according to the table.

Terminal	A	B	C
Position			
LOCK	○ — ○		
OFF			
UNLOCK		○ — ○	

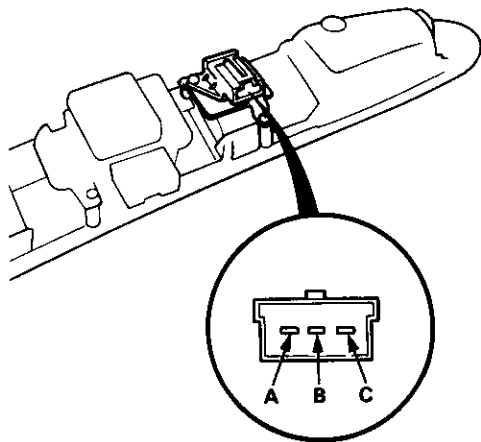



Wiper/Washer

Component Location Index

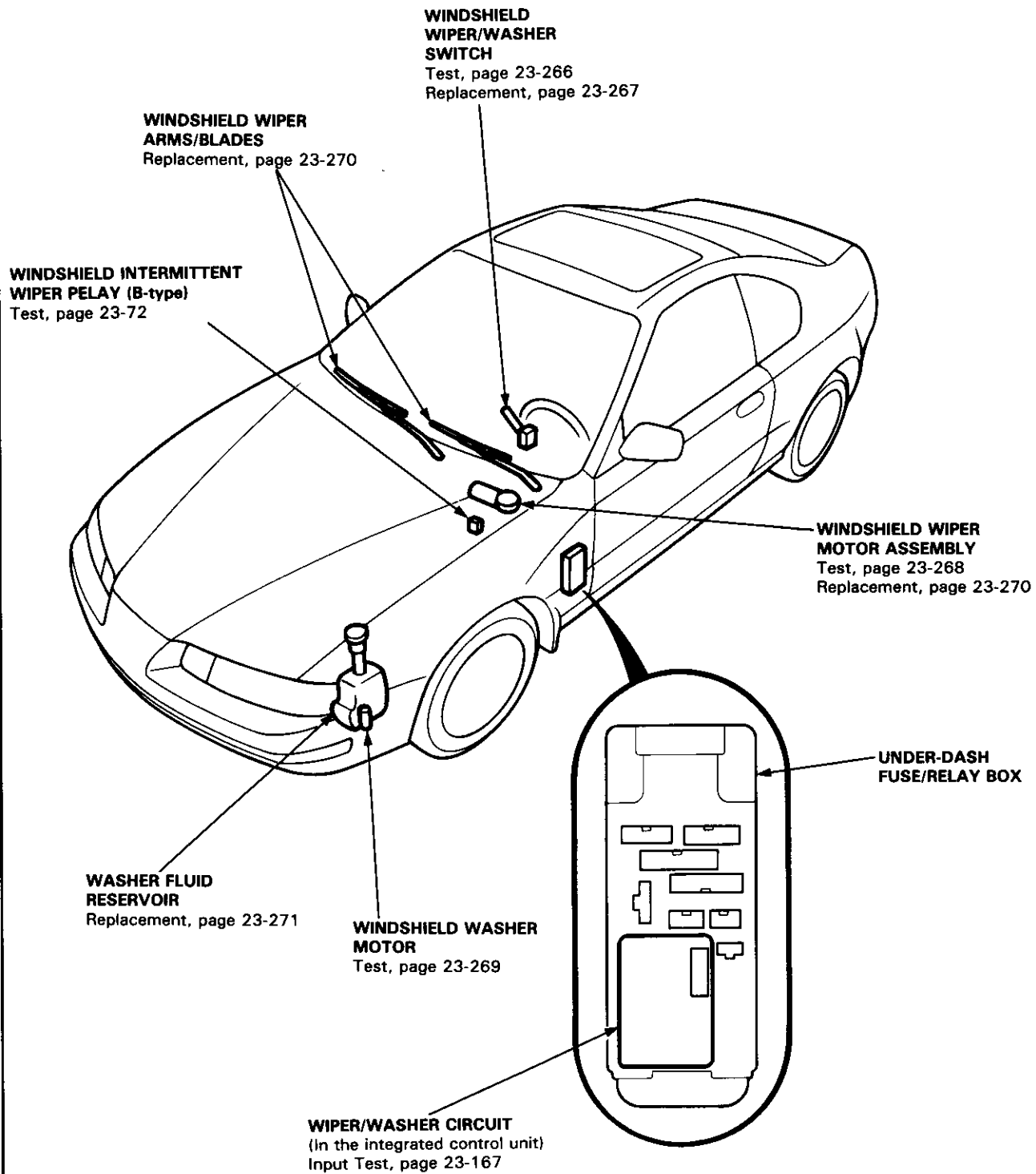

Wiper/Washer

Circuit Diagram

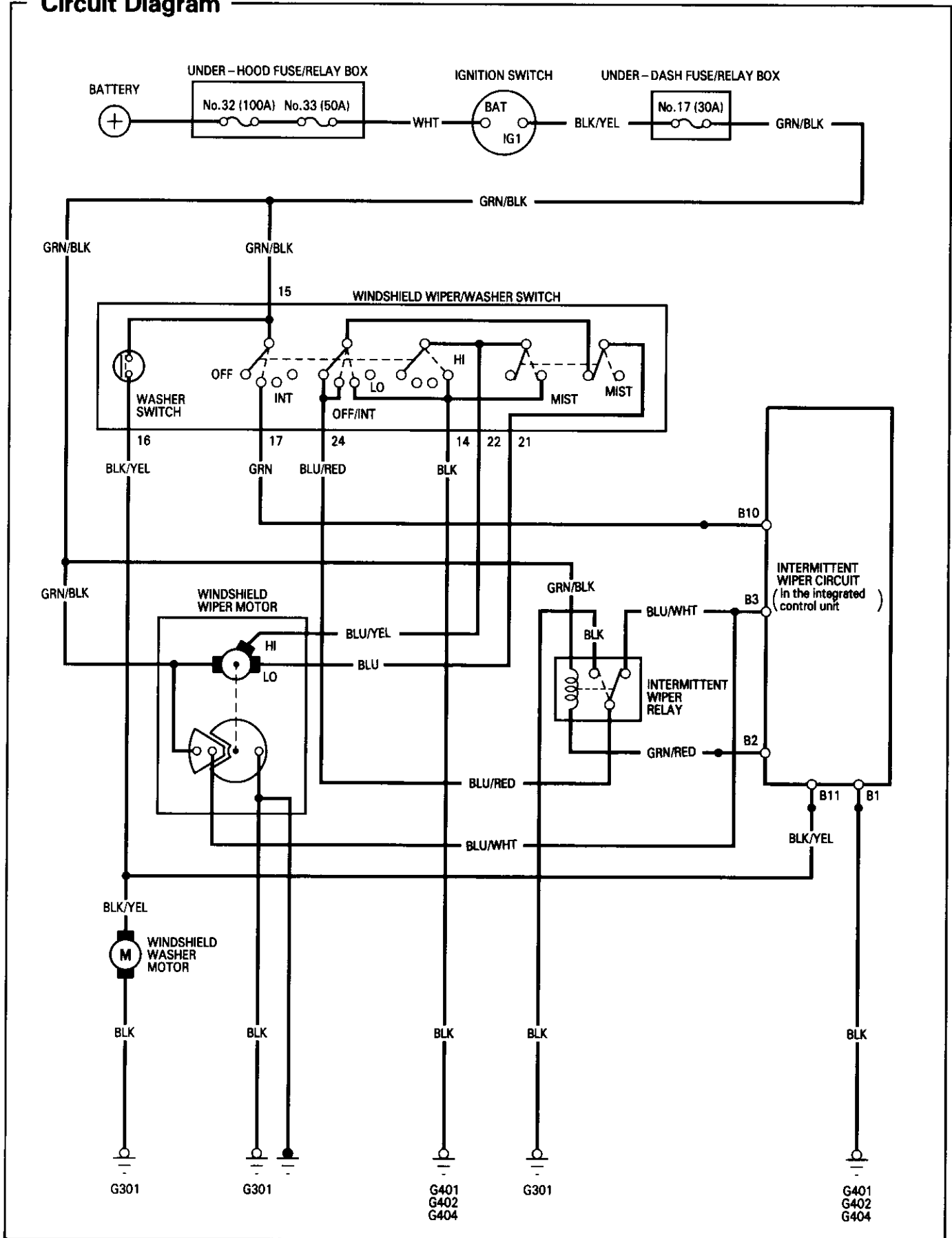



Troubleshooting

NOTE: The numbers in the table show the troubleshooting sequence.

Symptom		Item to be inspected											Poor ground	Open circuit, loose or disconnected terminals		
		Blown No. 17 (30 A) fuse (In the under-dash fuse/relay box)	Wiper switch	Mist switch	Wiper motor assembly	Washer switch	Washer motor	Intermittent wiper relay	Combined operation of wiper/washer (In the integrated control unit)	Not enough washer fluid in reservoir	Disconnected or blocked washer hose or clogged outlet	Disconnected wiper linkage				
Wipers do not work.	In all positions	1	4		2								3	G301 G401 G402 G404	GRN/BLK	
	In INT		1		3		2									GRN or BLU/WHT
	In LO or HI		1		2											BLU/YEL or BLU
	In MIST			1	2											BLU/YEL
Blades do not return to park position when wipers are turned OFF.			2		1										BLU/WHT	
Erratic intermittent cycle or wipers do not work in INT.							1	2							GRN/BLK, GRN, BLU/WHT or GRN/RED	
Little or no washer fluid is pumped.						4	3			1	2		G301		BLK/YEL	
Wipers and washer do not work at the same time.								1							BLK/YEL	

Wiper/Washer

Wiper/Washer Switch Test

1. Remove the dashboard lower cover and knee bolster.
2. Disconnect the 5-P and 20-P connectors from the main wire harness.
3. Check for continuity between the terminals in each position according to the table.

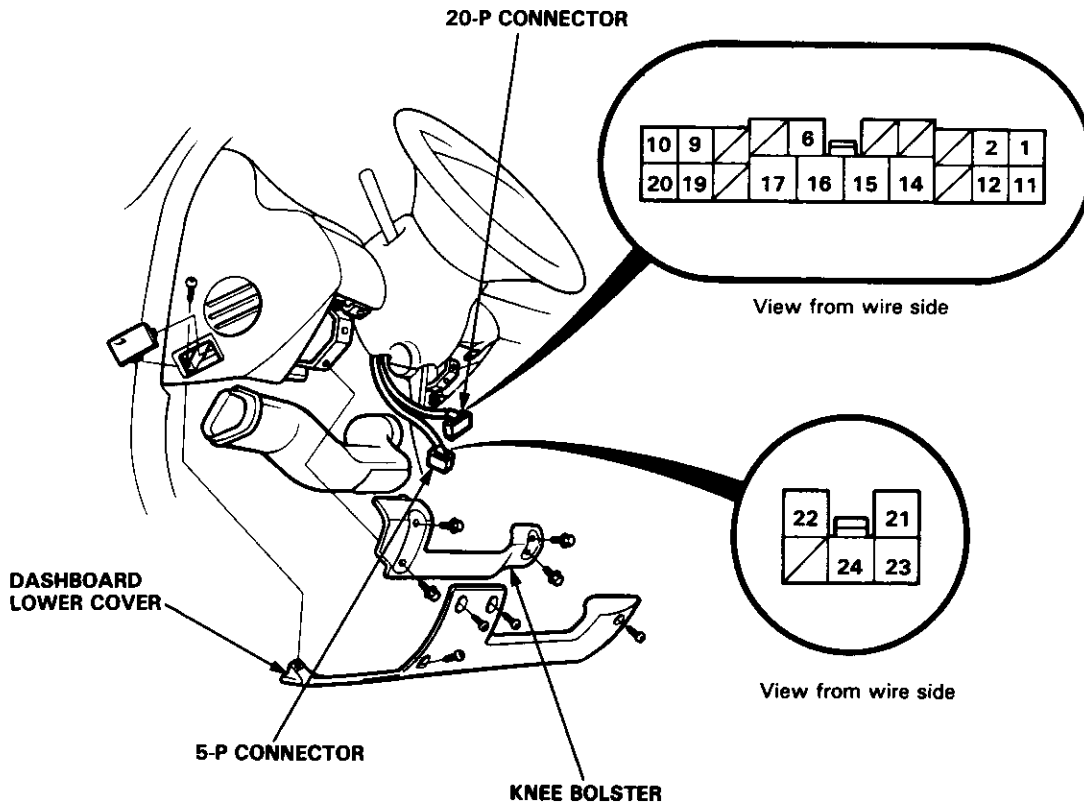

Terminal	14	15	16	17	21	22	24
Position							
OFF					○		○
INT		○		○	○		○
LO	○				○		
HI	○					○	
Mist switch "ON"	○					○	
Washer switch "ON"		○	○				



Wiper/Washer Switch Replacement

CAUTION:

- All SRS electrical wiring harnesses are covered with yellow outer insulation.
- Before disconnecting the SRS wire harness, install the short connector(s) on the airbag(s) (see page 23-294).
- Replace the entire affected SRS harness assembly if it has an open circuit or damaged wiring.

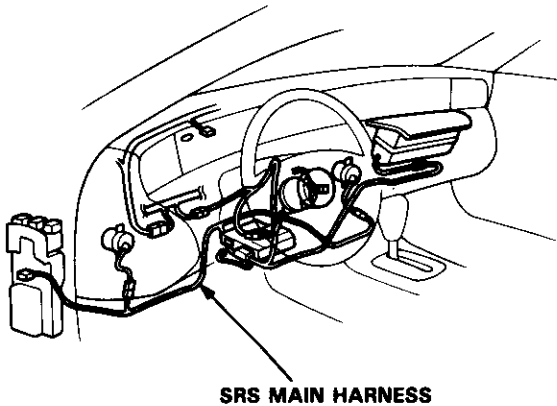

1. Remove the dashboard lower cover and knee bolster.

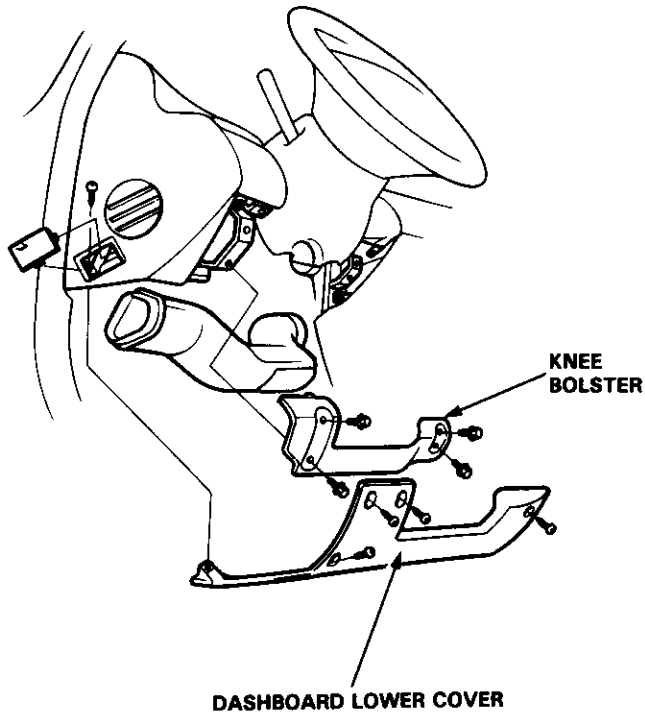

2. Remove the steering column covers.

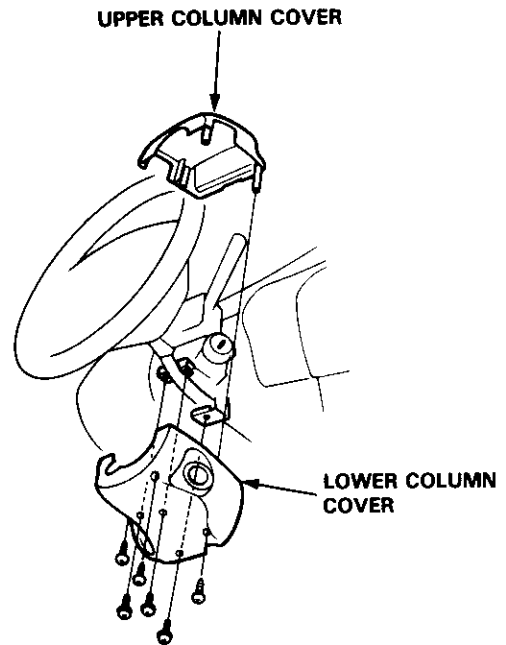

3. Disconnect the 8-P connector, then remove the wiper/washer switch.

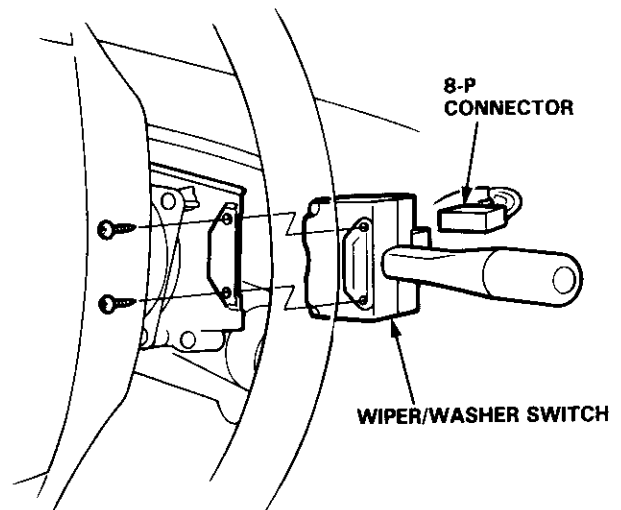

Wiper/Washer

Windshield Wiper Motor Test

1. Open the hood and remove the cap nuts and the wiper arms. Be careful not to damage the hood.
2. Disconnect the 5-P connector from the wiper motor assembly.

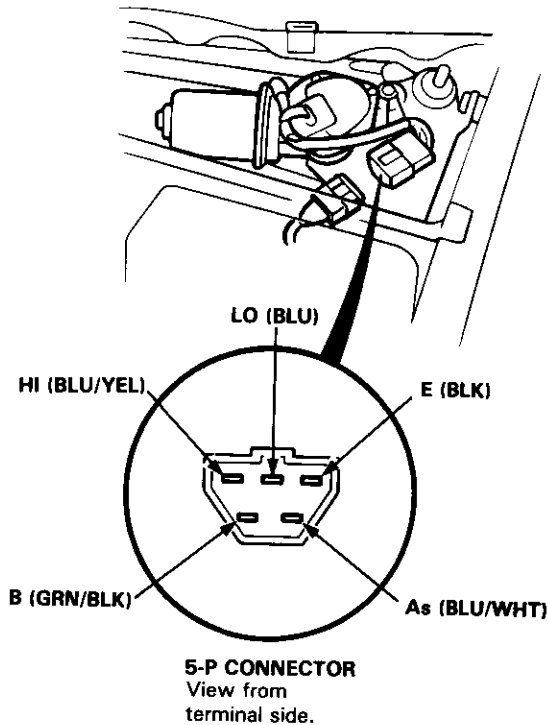

3. Test motor operation:

LOW SPEED: Connect battery power to the B (GRN/BLK) terminal and ground to the LO (BLU) terminal.

HIGH SPEED: Connect battery power to the B (GRN/BLK) terminal and ground to the HI (BLU/YEL) terminal.

4. If the motor does not run, or fails to run smoothly, replace it.

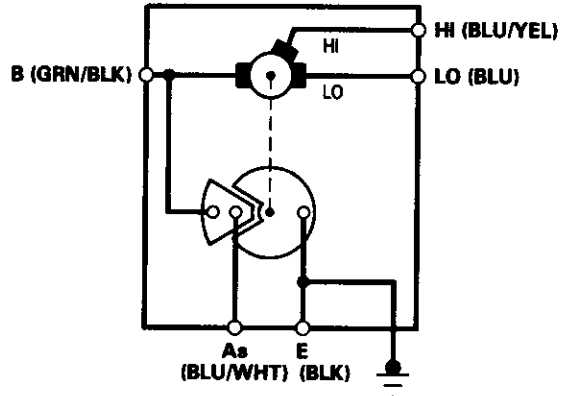

5. Reconnect the 5-P connector to the wiper motor assembly.
6. Connect an analog voltmeter between the As (BLU/WHT) and the E (BLK) terminals. Run the motor by turning the wiper switch ON (LO or HI position). The voltmeter should alternately indicate 0 V and more than 4 V.



Windshield Washer Motor Test

1. Remove the left inner fender.
2. Disconnect the 2-P connector from the washer motor.
3. Test the washer motor by connecting battery power to the \oplus terminal and grounding the \ominus terminal.
 - If the motor does not run, or fails to run smoothly, replace it.
 - If the motor runs smoothly, but little or no washer fluid is pumped, check for a disconnected or blocked washer hose, or a clogged pump outlet.

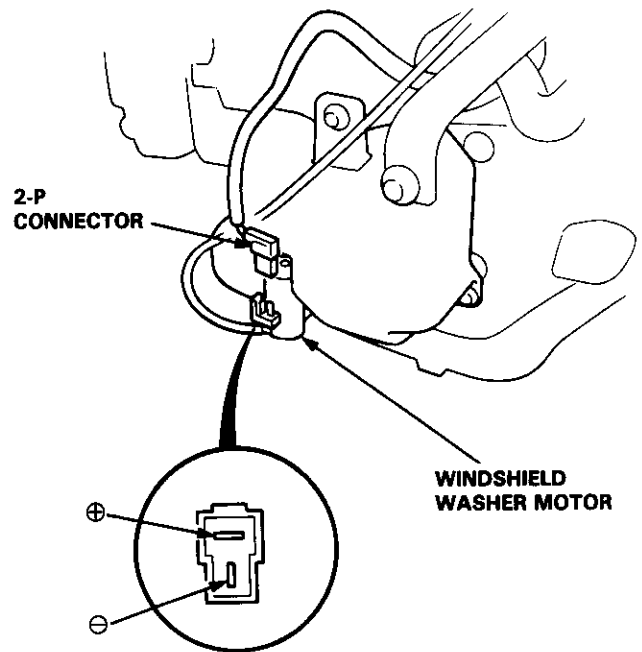

Wiper/Washer

Windshield Wiper Motor Replacement

1. Open the hood and remove the cap nuts and the wiper arms. Be careful not to damage the hood.
2. Remove the windshield lower molding, hood seal, and air scoop by prying the trim clips out and removing the screws.

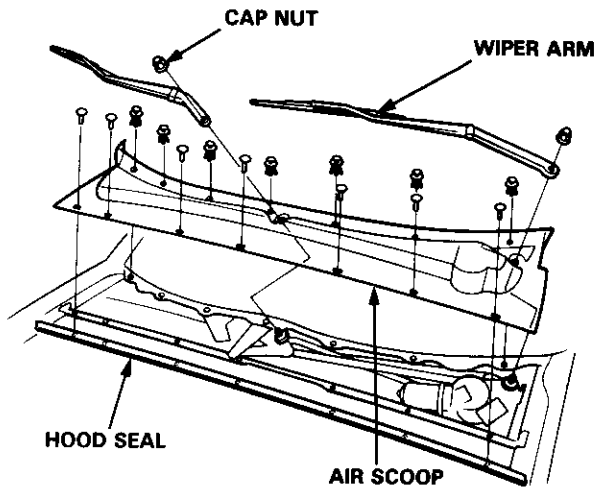

3. Disconnect the 5-P connector from the wiper motor, then remove the wiper harness from the wiper linkage.

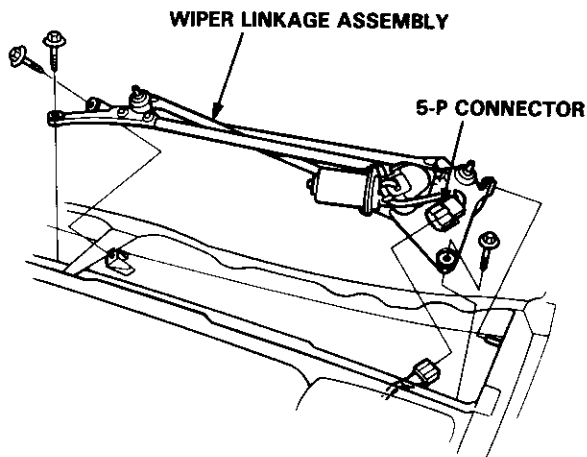

4. Remove the wiper linkage assembly by removing the three mounting bolts.

5. Remove the three mounting bolts and one nut from the wiper linkage, then remove the wiper motor.

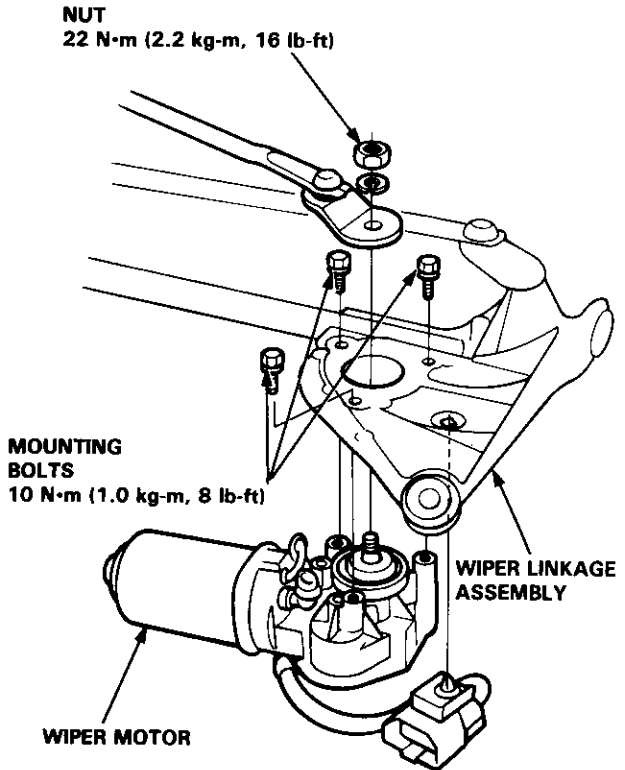



Washer Motor Replacement

1. Remove the washer filler neck.
2. Remove the inner fender.
3. Disconnect the hose and the 2-P connector from the washer motor.
4. Remove the three mounting bolts and pull out the washer reservoir.
5. Remove the washer motor from the washer reservoir.
6. Remove the washer nozzles and washer hose as necessary.
7. During installation take care not to pinch any hoses. Install the hose clips firmly.
8. After installing washer nozzles, check/adjust their aim.

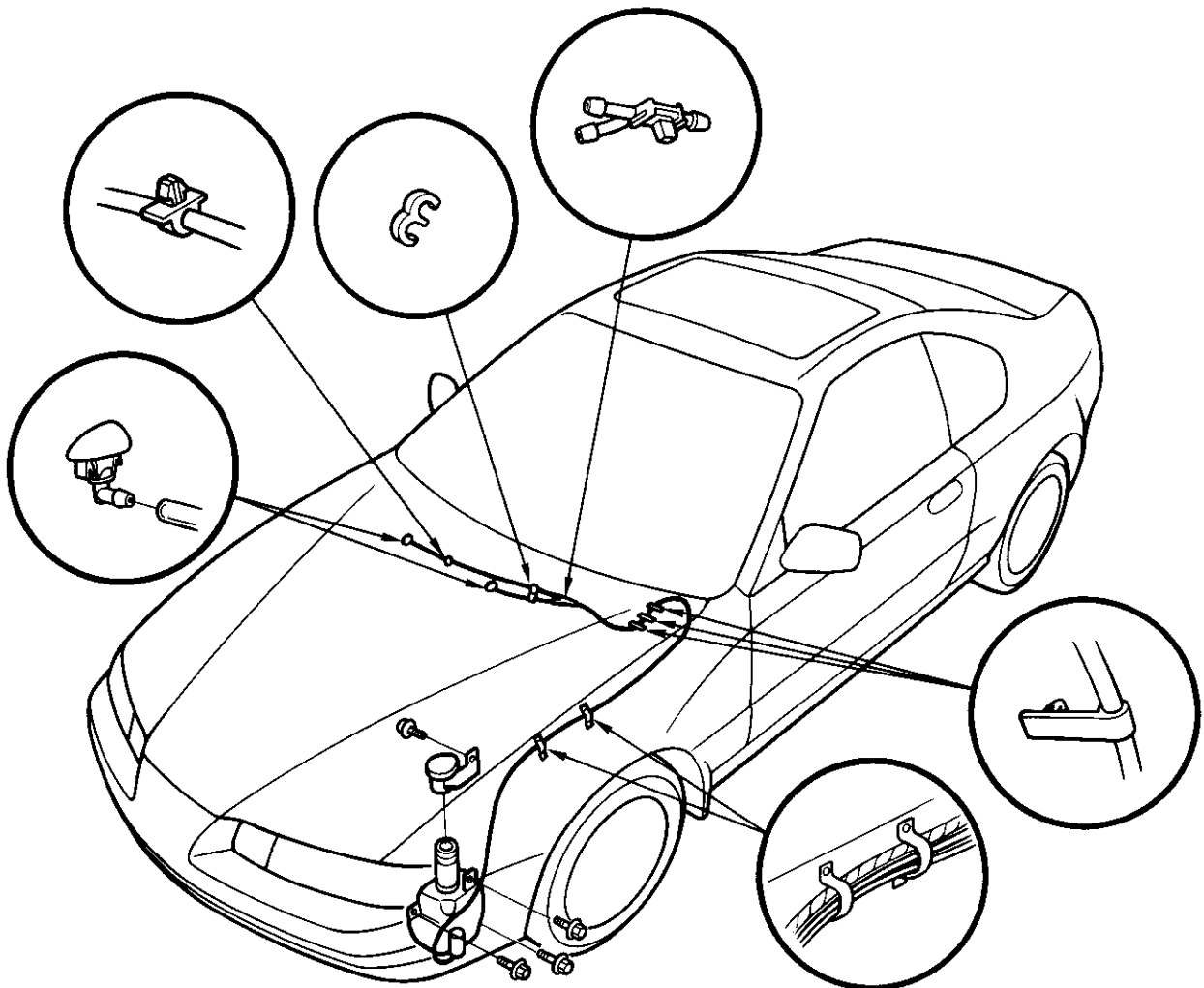

Cruise Control

Component Location Index

CAUTION:

- All SRS electrical wiring harnesses are covered with yellow outer insulation.
- Before disconnecting the SRS wire harness, install the short connector(s) on the airbag(s) (see page 23-294).
- Replace the entire affected SRS harness assembly if it has an open circuit or damaged wiring.

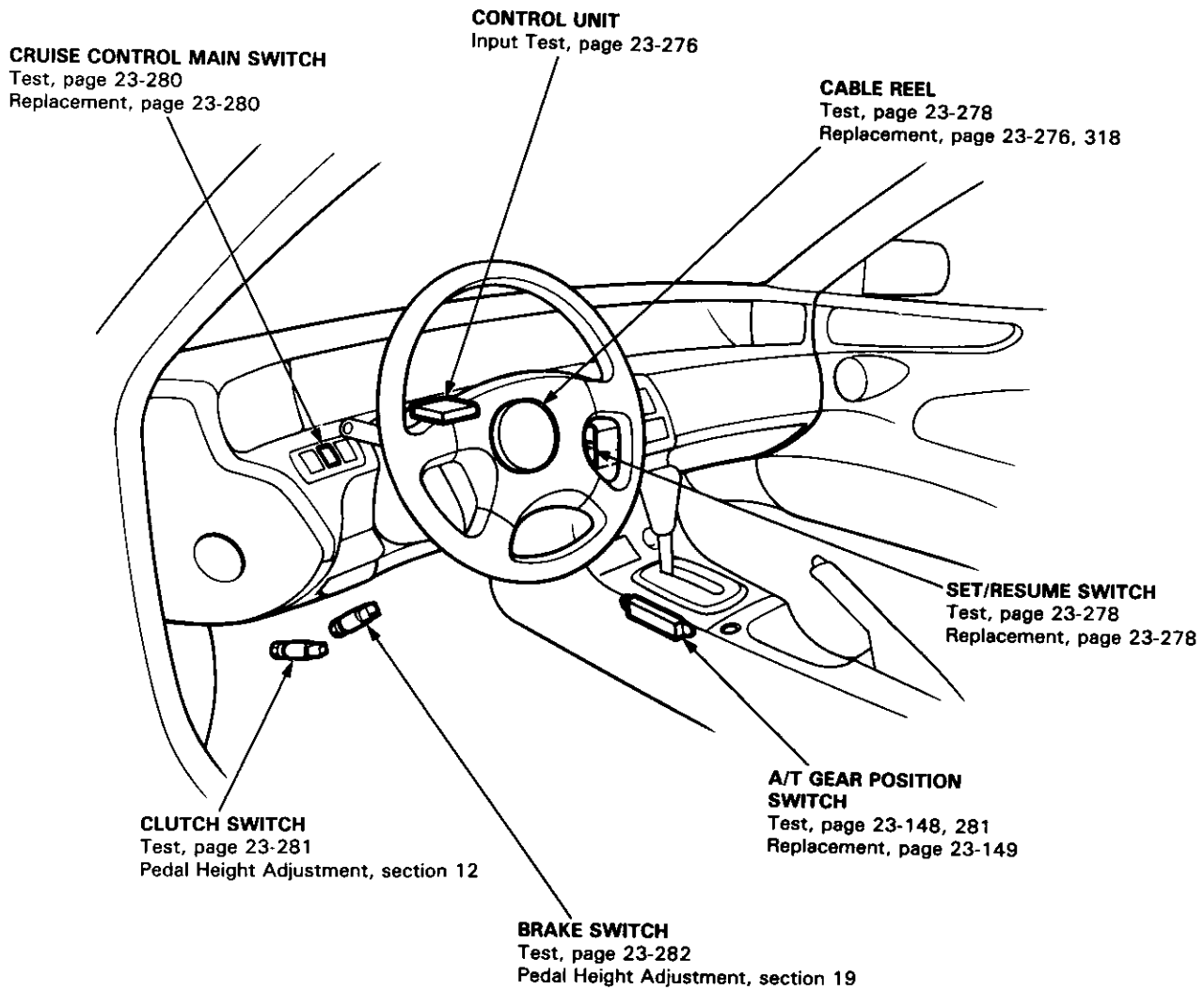
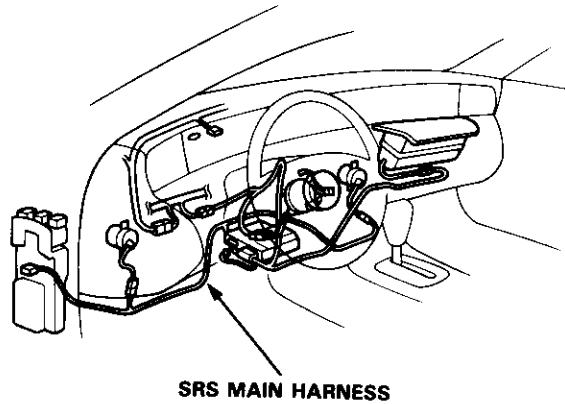

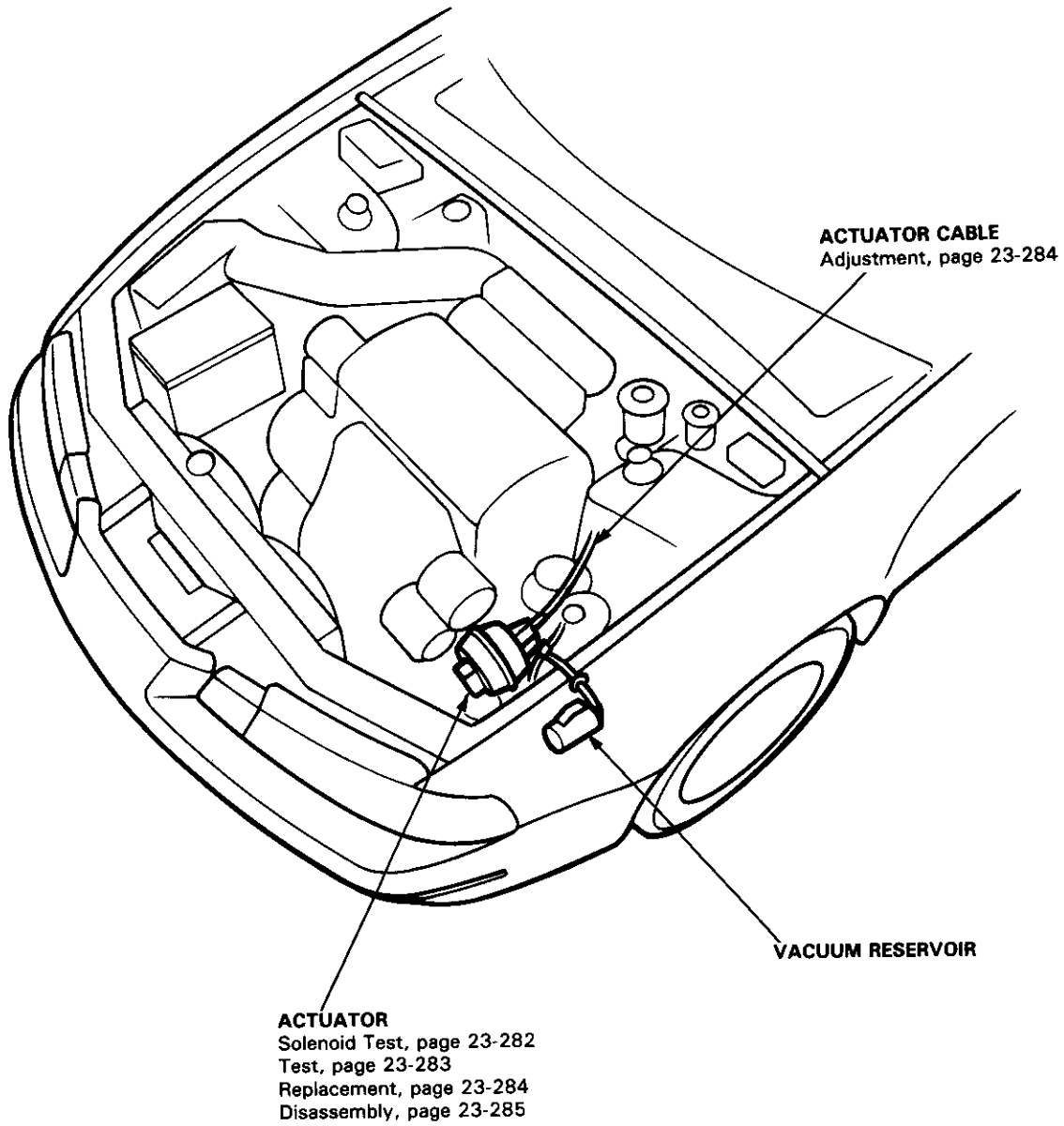

Cruise Control

Circuit Diagram

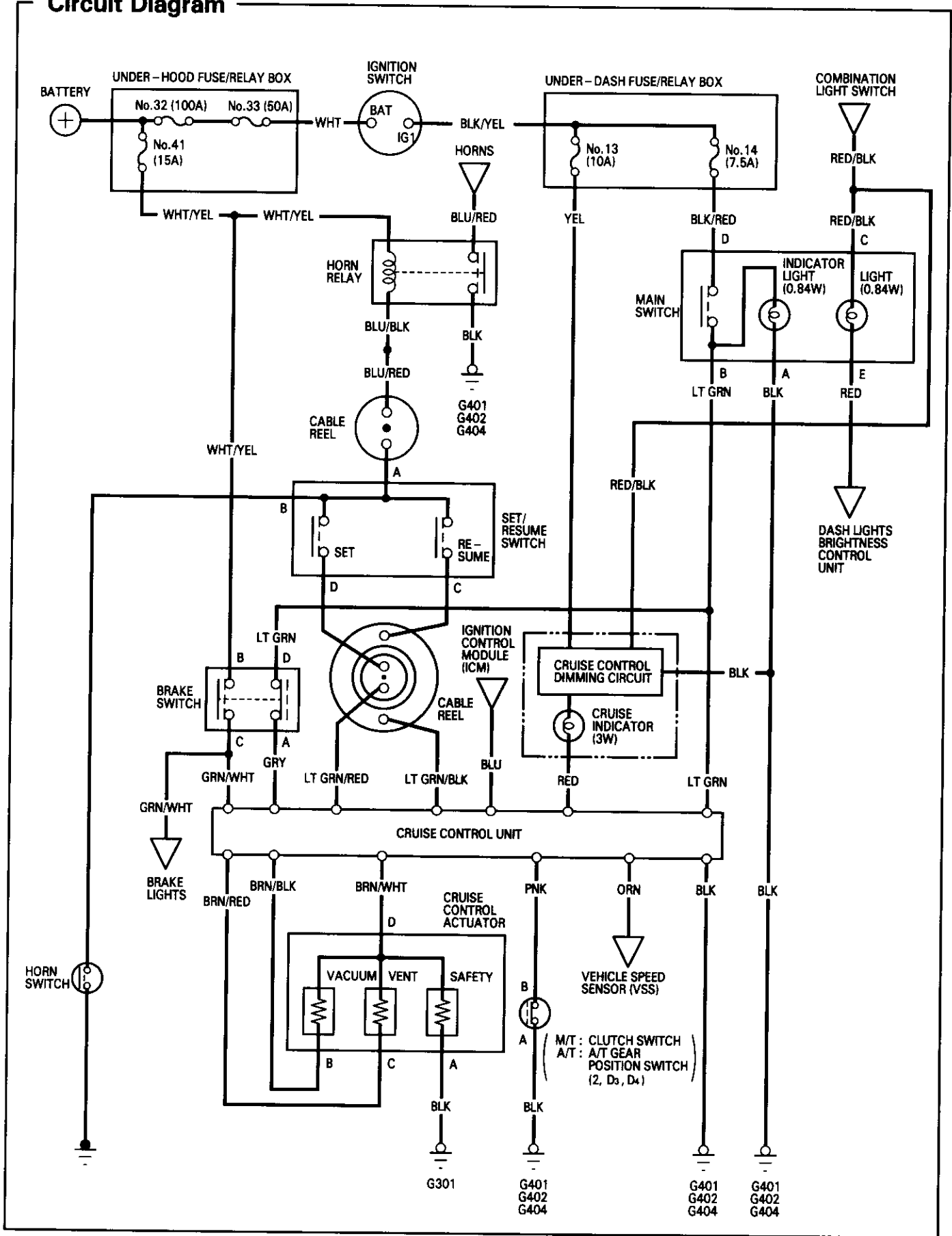



Troubleshooting

NOTE:

- The numbers in the table show the troubleshooting sequence.
- Before troubleshooting.
 - Check the No. 14 (7.5 A) fuse in the under-dash fuse/relay box and the No. 41 (15 A) fuse in the under-hood fuse/relay box.
 - Check that the horns sound.
 - Check the tachometer for proper operation.

Items to be inspected												
Symptom	Main switch	SET/RESUME switch	Brake switch/adjustment	Clutch switch/adjustment (M/T)	A/T gear position switch (A/T)	Dimming circuit in gauges	Actuator and cable free play	Vehicle speed sensor (VSS)	Disconnected, clogged or restricted vacuum lines, stuck check valve, leaky vacuum reservoir	Control unit input	Poor ground	Open circuit, loose or disconnected terminals
Cruise control cannot be set.	1	2								3	G401 G402 G404	LT GRN/BLK, BRN/WHT, BRN/BLK, BRN/RED, ORN, LT GRN LT GRN/RED, BLU
Cruise control can be set, but indicator light does not go on.						1					G401 G402 G404	YEL, RED, RED/BLK
Cruise speed noticeably higher or lower than what was set.							1	3		2		
Excessive overshooting and/or undershooting when trying to set speed.							1	3		2		
Steady speed not held, even on a flat road with cruise control set.							1	4	2	3		
Car does not decelerate or accelerate accordingly when SET or RESUME button is pushed.		1								2		
Set speed not cancelled when clutch pedal is pushed (M/T).				1						2		PNK
Set speed not cancelled when shift lever is moved to 1 (A/T).					1					2		PNK
Set speed not cancelled when brake pedal is pushed			1							2		GRY, GRN/WHT
Set speed not cancelled when main switch is pushed OFF.	1									2		LT GRN
Set speed not resumed when RESUME button is pushed (with main switch ON, but set speed temporarily cancelled).		1								2		

Cruise Control

Control Unit Input Test

CAUTION:

- All SRS electrical wiring harnesses are covered with yellow outer insulation.
- Before disconnecting the SRS wire harness, install the short connector(s) on the airbag(s) (see page 23-294).
- Replace the entire affected SRS harness assembly if it has an open circuit or damaged wiring.

1. Disconnect the 14-P connector from the control unit.
2. Inspect the connector and socket terminals to be sure they are all making good contact.

- If the terminals are bent, loose, or corroded, repair them as necessary, and recheck the system.
- If the terminals look OK, make the following input tests at the connector.
 - If a test indicates a problem, find and correct the cause, then recheck the system.
 - If all the input tests prove OK, the control unit must be faulty; replace it.

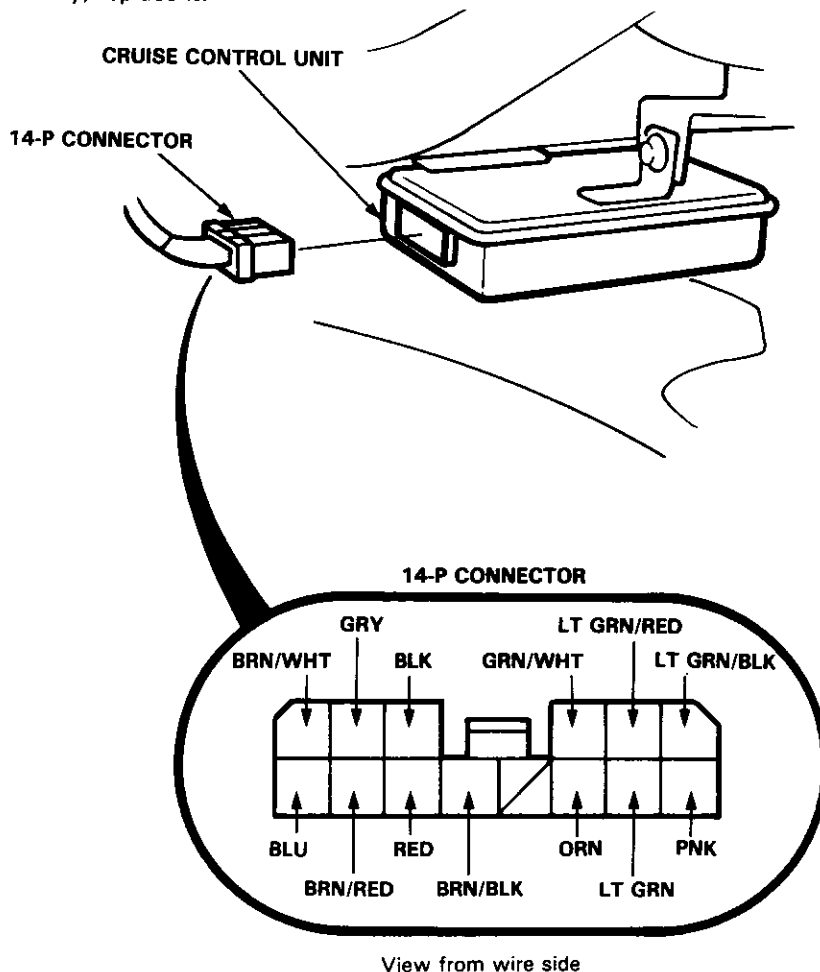
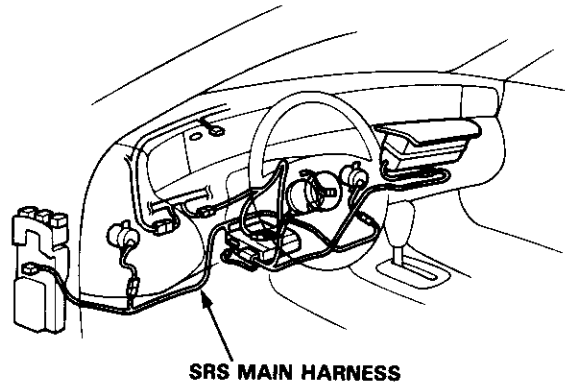



No.	Wire	Test condition	Test: Desired result	Possible cause if result is not obtained
1	BLK	Under all conditions.	Check for continuity to ground: There should be continuity.	<ul style="list-style-type: none"> • Poor ground (G401, G402, G404) • An open in the wire.
2	LT GRN	Ignition switch ON and main switch ON.	Check for voltage to ground: There should be battery voltage.	<ul style="list-style-type: none"> • Blown No. 14 (7.5 A) fuse. (In the under-dash fuse/relay box) • Faulty main switch. • An open in the wire.
3	LT GRN/ BLK	RESUME button pushed.	Check for voltage to ground: There should be battery voltage.	<ul style="list-style-type: none"> • Blown No. 41 (15 A) fuse. (In the under-hood fuse/relay box) • Faulty SET/RESUME switch. • Faulty cable reel. • An open in the wire.
4	LT GRN/ RED	SET button pushed.		
5	PNK	M/T: Clutch pedal pushed. A/T: Shift lever in 2 , D₃ , or D₄ .	Check for continuity to ground: There should be continuity. NOTE: There should be no continuity when the clutch pedal is released or when the A/T shift lever is in other positions.	<ul style="list-style-type: none"> • Faulty or misadjusted clutch switch (M/T). • Faulty or misadjusted A/T gear position switch. • Poor ground (G401, G402, G404). • An open in the wire.
6	BLU	Start the engine.	Check for voltage to ground: There should be battery voltage.	<ul style="list-style-type: none"> • Faulty ignition system or ECM. • An open in the wire.
7	ORN	Ignition switch ON and main switch ON. Raise the front of the car, rotate one wheel slowly.	Check for voltage between the ORN ⊕ and BLK ⊖ terminals: It should be 0–12–0–12 V repeatedly.	<ul style="list-style-type: none"> • Faulty vehicle speed sensor (VSS). • Poor ground (G101). • An open in the wire.
8	GRY	Ignition switch ON, main switch ON and brake pedal pushed, then released.	Check for voltage to ground: There should be 0 V with the pedal pushed, and battery voltage with the pedal released.	<ul style="list-style-type: none"> • Faulty brake switch. • An open in the wire.
9	GRN/WHT	Brake pedal pushed, then released.	Check for voltage to ground: There should be battery voltage with the pedal pushed, and 0 V with the pedal released.	<ul style="list-style-type: none"> • Faulty brake switch. • An open in the wire.
10	RED	Ignition switch ON.	Connect to ground: Cruise indicator in the gauge assembly comes on.	<ul style="list-style-type: none"> • Blown bulb. • Blown No. 13 (10 A) fuse. (In the under-dash fuse/relay box) • Faulty dimming circuit in the gauge assembly. • An open in the wire.
11	BRN/RED	Under all conditions.	Check for resistance to ground: There should be 80–120 Ω.	<ul style="list-style-type: none"> • Faulty actuator solenoid. • An open in the wire.
12	BRN/BLK	Under all conditions.	Check for resistance to ground: There should be 70–110 Ω.	
13	BRN/WHT	Under all conditions.	Check for resistance to ground: There should be 40–60 Ω.	

Cruise Control

Set/Resume Switch Test/Replacement

CAUTION:

- All SRS electrical wiring harnesses are covered with yellow outer insulation.
- Before disconnecting the SRS wire harness, install the short connector(s) on the airbag(s) (see page 23-294).
- Replace the entire affected SRS harness assembly if it has an open circuit or damaged wiring.

NOTE: The radio may have a coded theft protection circuit. Be sure to get the customer's code number before

- Disconnecting the battery.
- Removing the No. 43 (10 A) fuse. (In the under-hood fuse/relay box)
- Removing the radio.

After service, reconnect power to the radio and turn it on.

When the word "CODE" is displayed, enter the customer's 5-digit code to restore radio operation.

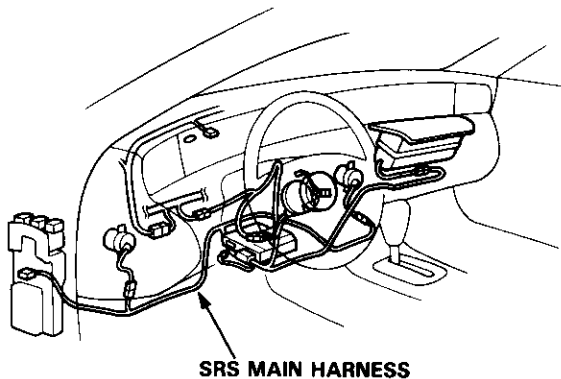

1. Disconnect the battery negative cable, and then positive cable.
2. Make sure the wheels are turned straight ahead.
3. Remove the two screws and access panel, then remove the short connector from the access panel.
4. Disconnect the airbag connector from the cable reel connector.

5. Install the short connector on the airbag connector.

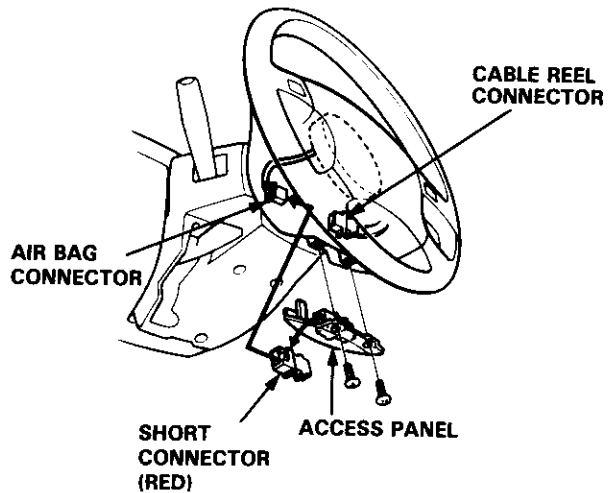

6. Remove the dashboard lower cover and knee bolster.
7. Disconnect the cable reel 6-P connector from the SRS main harness, then connect Test Harness C only to the cable reel side of the 6-P connector.

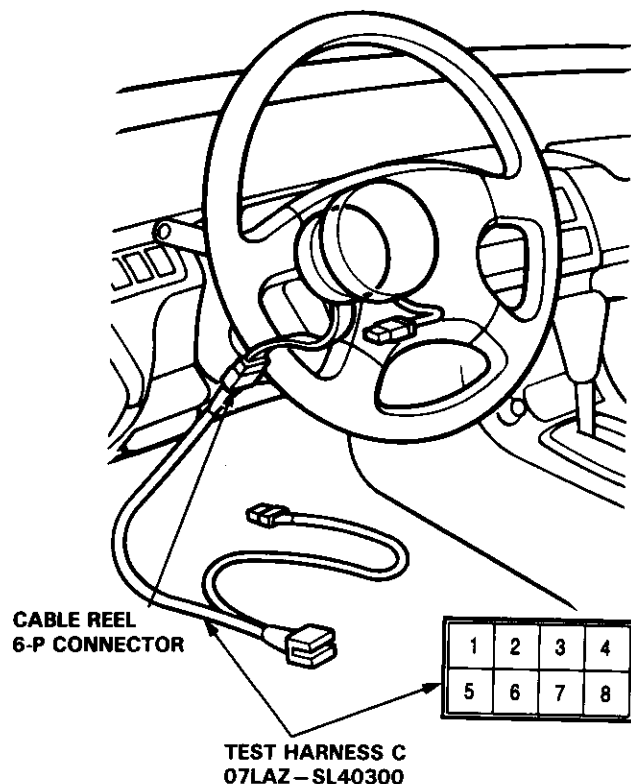



8. Check for continuity between the terminals of Test Harness C in each switch position according to the table.

Terminal Position	3 BLU/RED	2 LT GRN/ RED	1 LT GRN/ BLK
SET (ON)	○	○	
RESUME(ON)	○		○

- If there is continuity, and it matches the table, the switch is OK.
- If there is no continuity in one or both positions, go to step 9.

9. Carefully remove the cruise control SET/RESUME switch cover by prying between the cover and switch in the sequence shown.

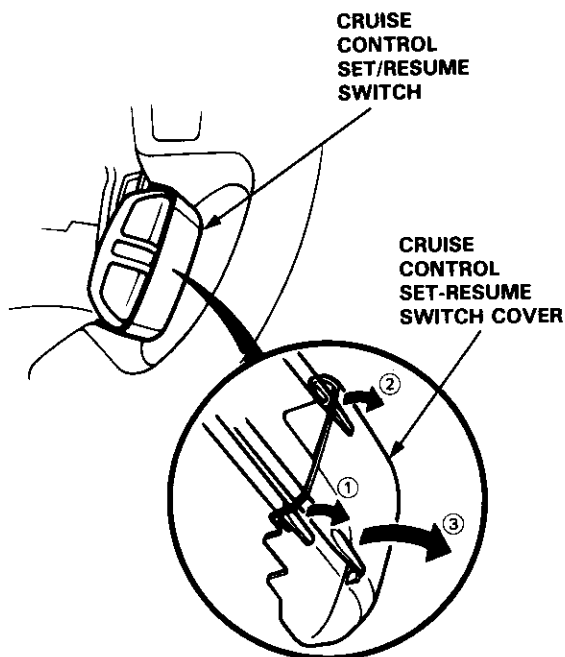

10. Remove the two screws and cruise control SET/RESUME switch.

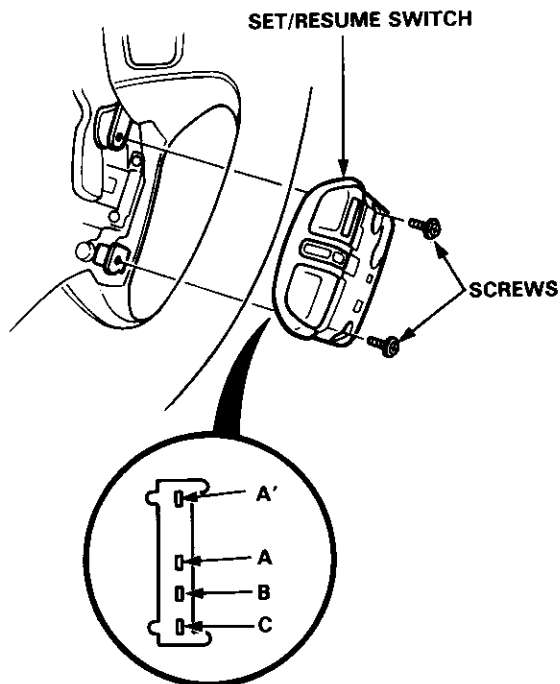

11. Check for continuity between the terminals in each switch position according to the table.

Terminal Position	A or A'	B	C
SET (ON)	○		○
RESUME (ON)	○	○	

- If there is no continuity in one or both positions, replace the switch.
- If there is continuity and it matches the table, replace the cable reel.

Cruise Control

Main Switch Test/Replacement

- Carefully pry the switches out of the instrument panel and disconnect their connectors.

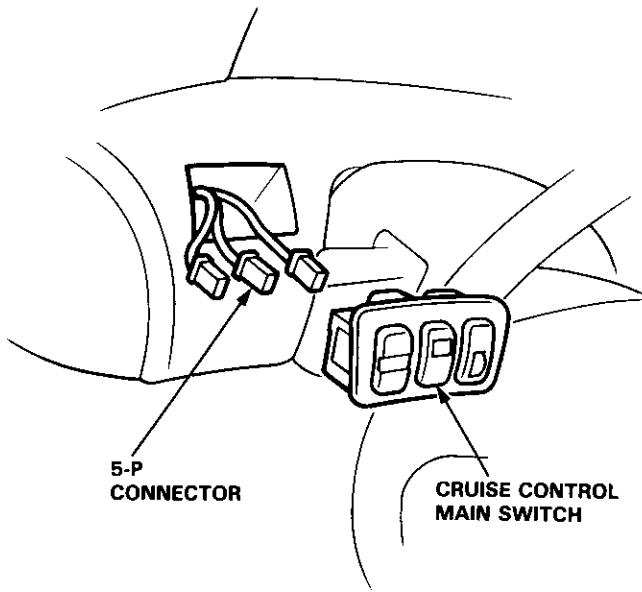

- Remove the cruise control main switch from the switch panel.

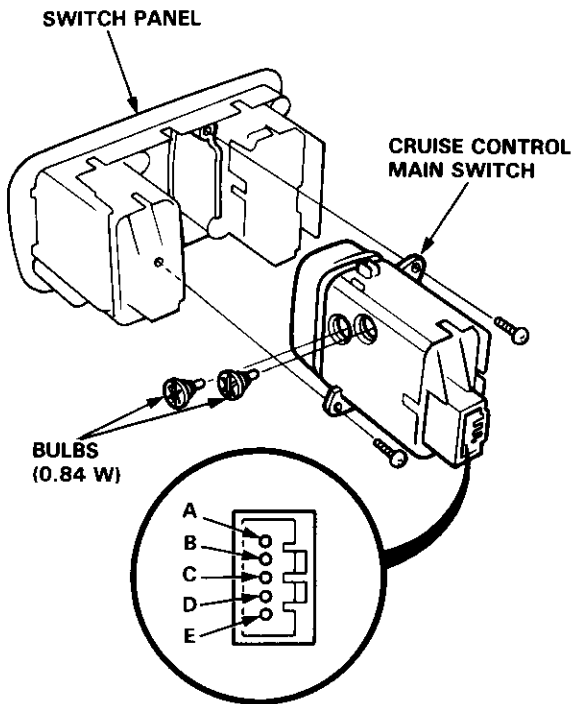

- Check for continuity between the terminals in each switch position according to the table.

Terminal	D	B		A	C		E
Position							
OFF		○	⊗	○	○	⊗	○
ON	○	○	⊗	○	○	⊗	○

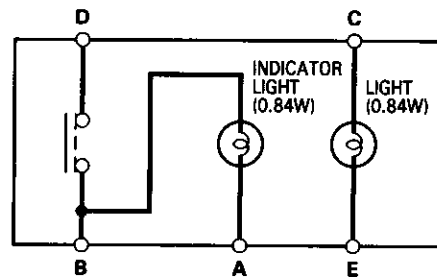

- If there is no continuity, replace the switch.



Clutch Switch Test

1. Disconnect the 3-P connector from the clutch switch.
2. Check for continuity between the terminals according to the table.

Terminal	B	C
Clutch Pedal		
PUSHED		
RELEASED		

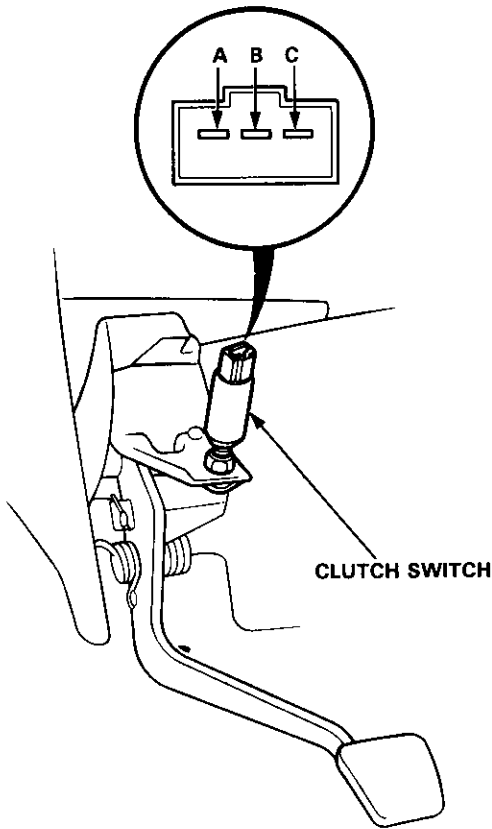

3. If necessary, replace the switch or adjust pedal height (see section 12).

A/T Gear Position Switch Test

1. Remove the front console, then disconnect the 12-P connector from the switch.

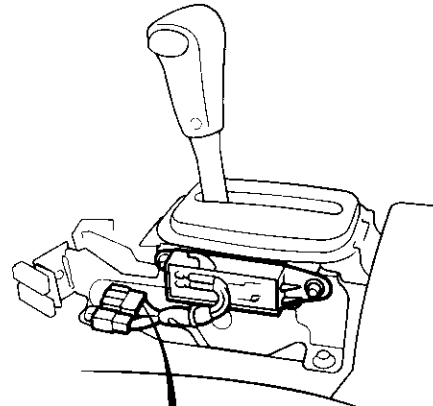

View from wire side

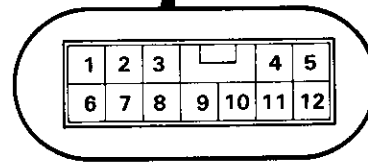

2. Check for continuity between the terminals in each switch position according to the table.

Terminal	5	8
Position		
1		
2		
D ₃		
D ₄		
N		
R		
P		

3. If necessary, replace the switch (see page 23-149).

Cruise Control

Brake Switch Test

1. Disconnect the 4-P connector from the switch.

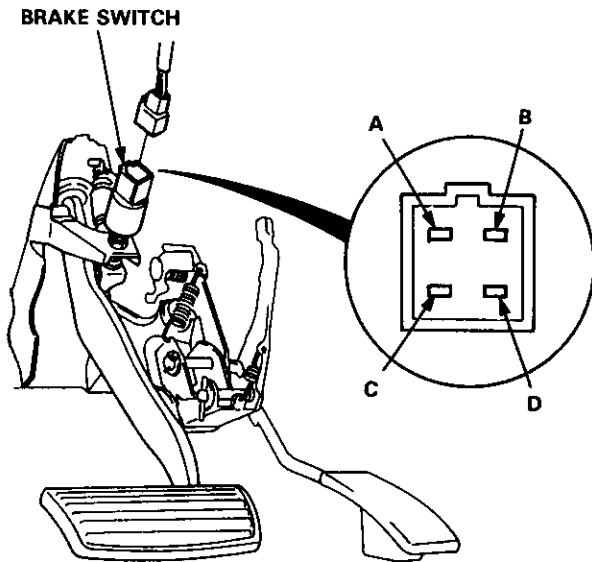

2. Check for continuity between the terminals according to the table.

Terminal	A	B	C	D
Brake Pedal				
PUSHED		○	○	
RELEASED	○			○

3. If necessary, replace the switch or adjust pedal height (see section 19).

Actuator Solenoid Test

1. Disconnect the 4-P connector from the actuator.

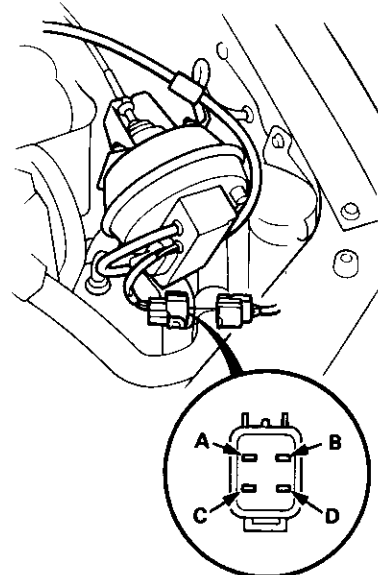

View from terminal side

2. Measure resistance between the terminals.

Resistance

VENT SOLENOID (between C and D):
80–120 Ω

VACUUM SOLENOID (between B and D):
70–110 Ω

SAFETY SOLENOID (between A and D):
40–60 Ω

NOTE: Resistance will vary slightly with temperature; specified resistance is at 70°F (20°C).

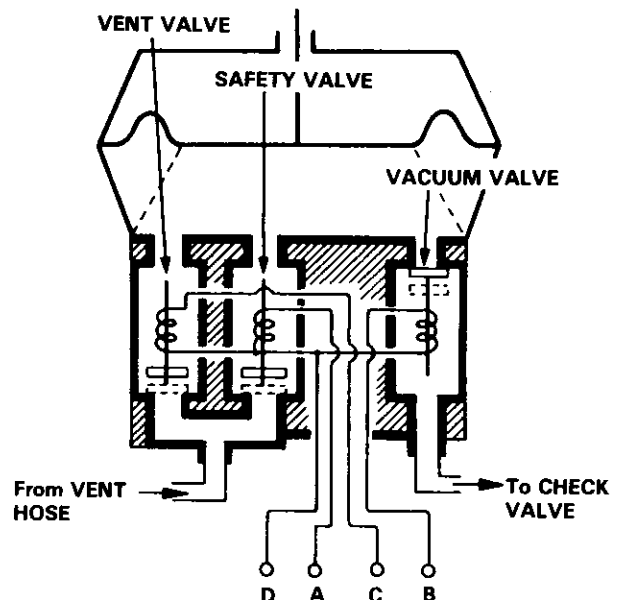



Actuator Test

1. Disconnect the actuator cable from the actuator rod and disconnect the 4-P connector.
2. Connect battery power to the D terminal and ground to the A, B, and C terminals.
3. Connect a vacuum pump to the check valve. Then apply vacuum to the actuator.

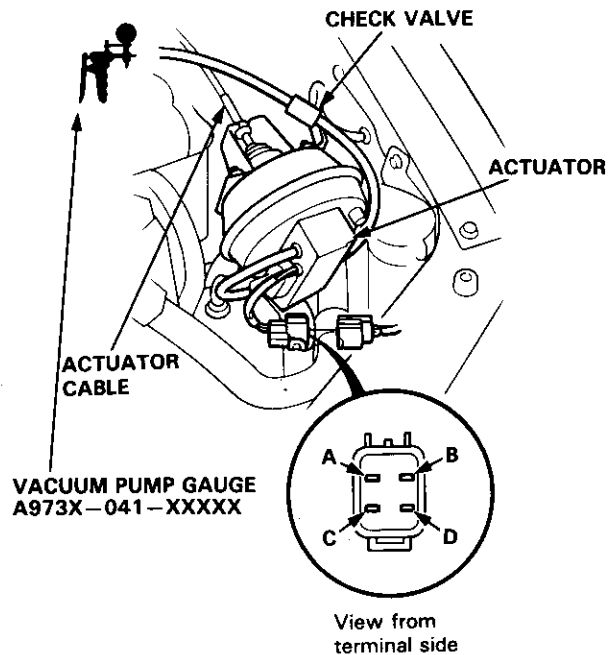

4. The actuator rod should pull in completely. If the rod pulls in only part-way or not at all, check for a leaking vacuum line or defective solenoid.

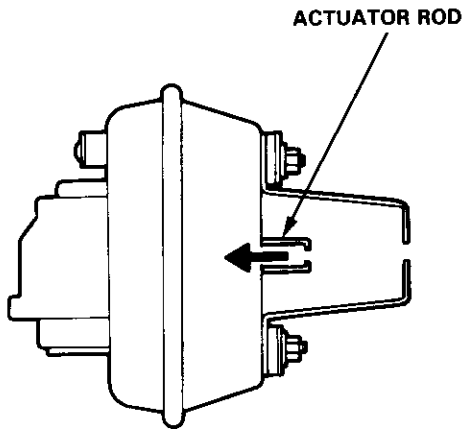

5. With voltage and vacuum still applied, try to pull the actuator rod out by hand. You should not be able to pull out. If you can, it is defective.

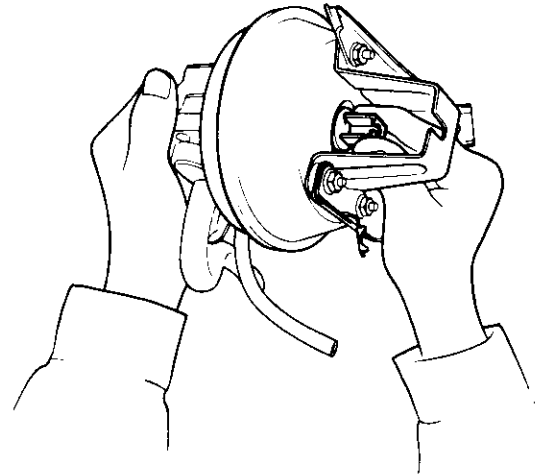

6. Disconnect ground from the C terminal. The actuator rod should return. If it does not return but the vent hose and filter are not plugged, the solenoid valve assembly is defective.
7. Repeat steps 2 through 5, and disconnect ground from the A terminal. The actuator rod should return. If it does not return but the vent hose and filter are not plugged, the solenoid valve assembly is defective.
8. If you replace the solenoid valve assembly, be sure to use new O-rings on each solenoid.

Cruise Control

Actuator/Cable Replacement

1. Pull the boot back and loosen the locknut, then disconnect the cable from the bracket.

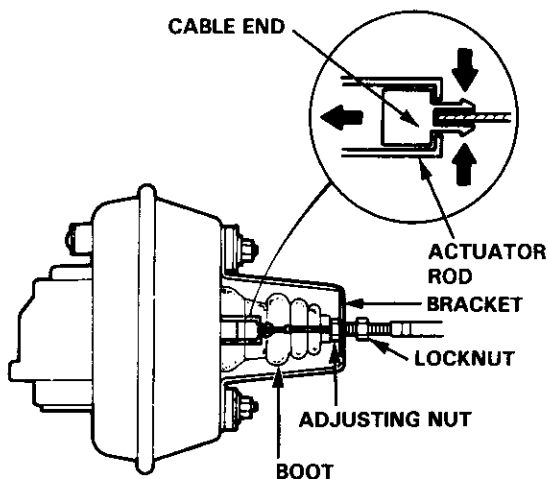

2. Disconnect the cable end from the actuator rod.
3. Disconnect the 4-P connector from the actuator.

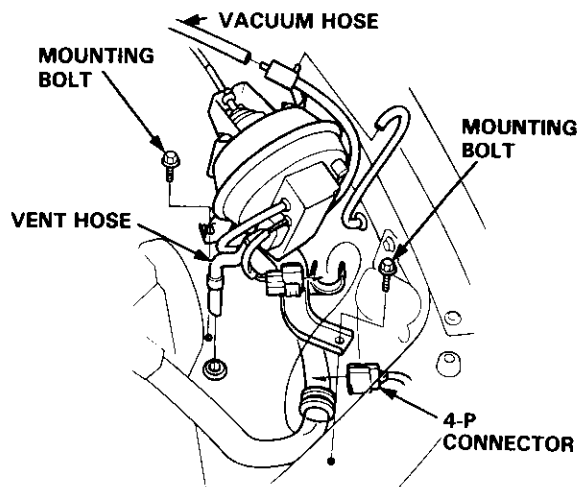

4. Pull the vent hose out of its grommet.
5. Remove the two mounting bolts and the actuator with the bracket.
6. Disconnect the vacuum hose from the check valve.
7. If necessary, disconnect the cable end from the linkage over the accelerator pedal, then turn the grommet 90° in the bulkhead and remove the cable.
8. Install in the reverse order of removal, and adjust free play at the actuator rod after connecting the cable (see next column).

Actuator Cable Adjustment

1. Check that the actuator cable operates smoothly with no binding or sticking.
2. Start the engine.
3. Measure the amount of movement of the actuator rod until the cable pulls on the accelerator lever (engine speed starts to increase). Free play should be 11 ± 1.5 mm (0.43 ± 0.06 in).

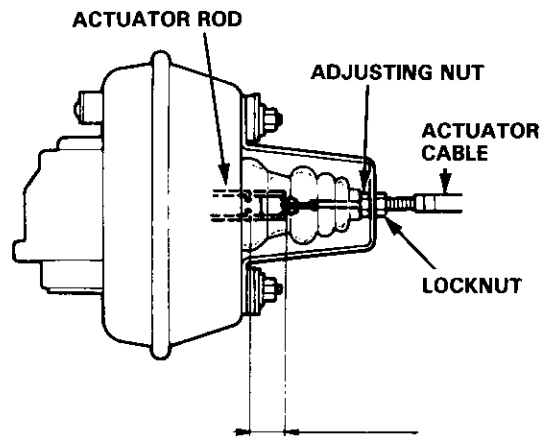

LOCKNUT FREE PLAY: 11 ± 1.5 mm
(0.43 ± 0.06 in)

4. If free play is not within specs, loosen the locknut and turn the adjusting nut as required.

NOTE: If necessary, check the throttle cable free play (see section 11), then recheck the actuator rod free play.

5. Retighten the locknut and recheck the free play.



Actuator Disassembly

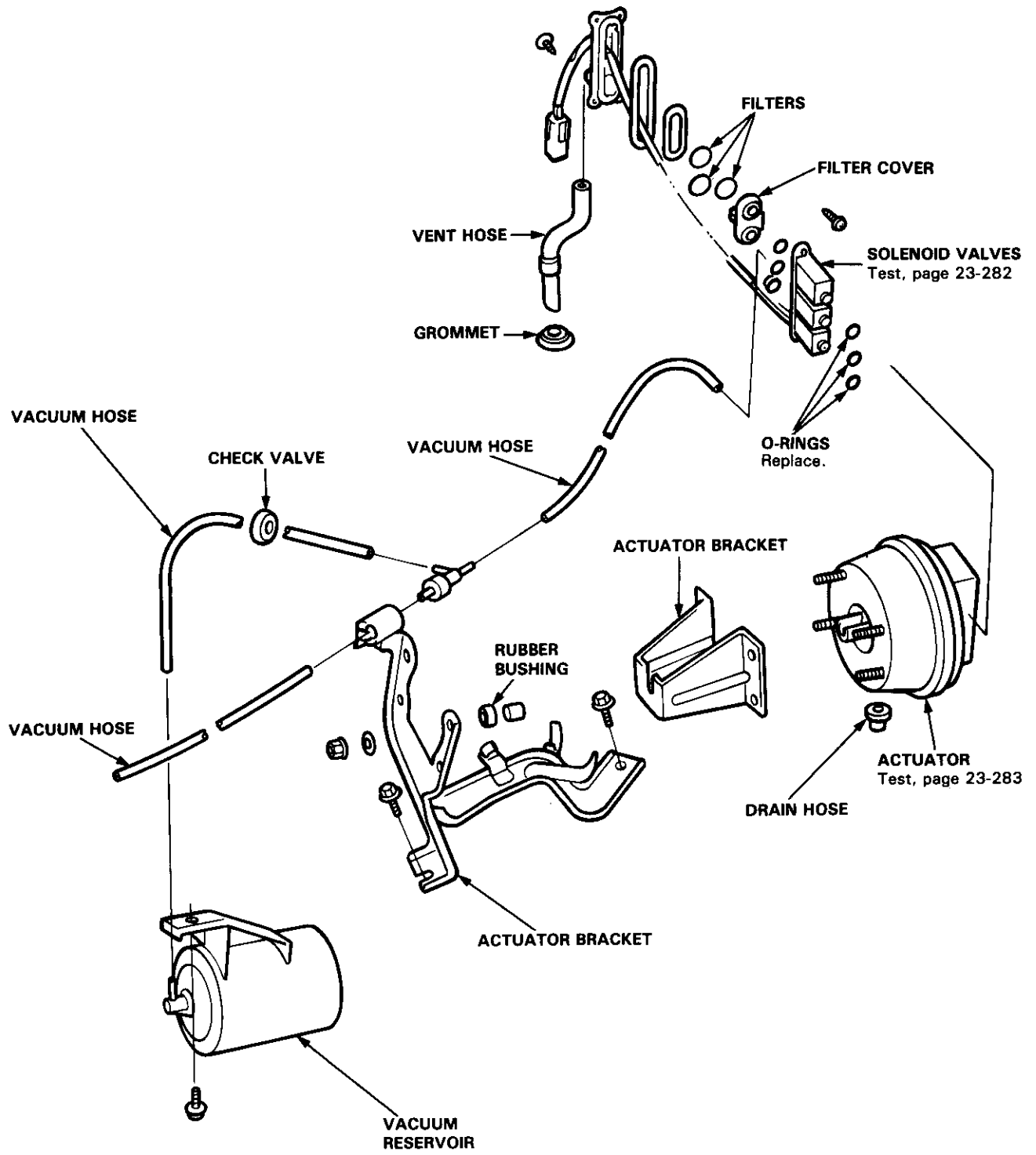

Supplemental Restraint System (SRS)

Component Location Index	23-288
Description	23-289
Circuit Diagram	23-290
Wiring Locations	23-292
Precautions/Procedures	23-293
Troubleshooting	23-298
Airbag Assembly	
Replacement	23-318
Disposal	23-322
Cable Reel	
Replacement	23-324
Dash Sensor	
Replacement	23-328
SRS Unit	
Replacement	23-330



Supplemental Restraint System (SRS)

Component Location Index

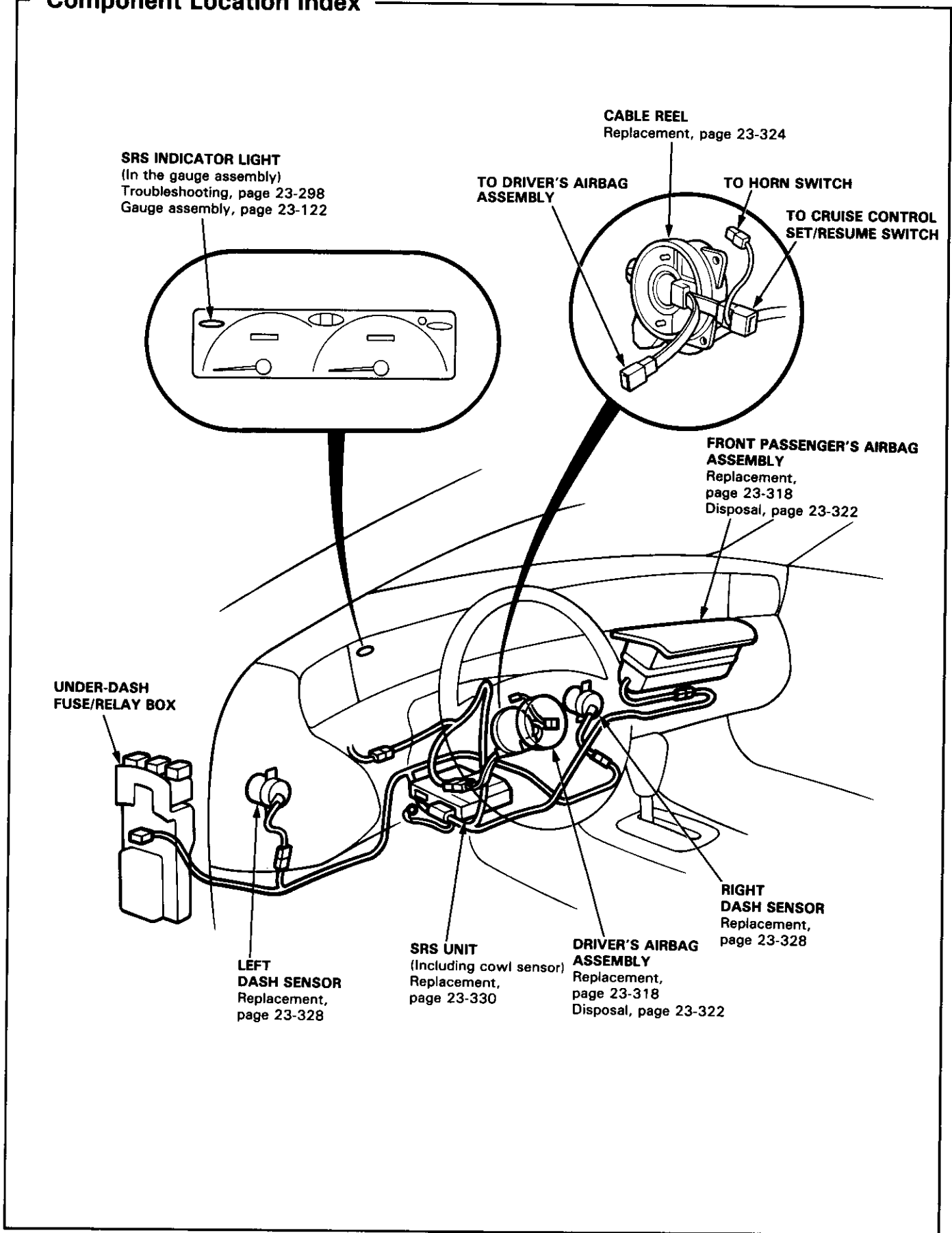



Description

The SRS is a safety device which, when used in conjunction with the seat belt, is designed to help protect the driver (and front passenger) in a frontal impact exceeding a certain set limit.

The system is composed of left and right dash sensors, the SRS unit (includes cowl sensors), the cable reel, driver's airbag and front passenger's airbag (Si 4WS, Si VTEC: USA, SR 4WS, SR-V: Canada models).

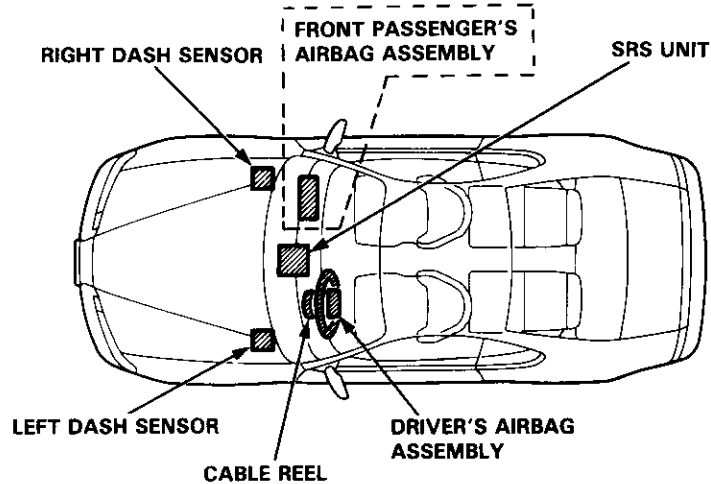

OPERATION:

As shown in the diagram below, the left and right dash sensors are connected in parallel. The parallel set of sensors is connected in series to each airbag inflator circuit and the car battery. In addition, a back-up power circuit is connected in parallel with the car battery. The back-up power circuit and the cowl sensors are located inside the SRS unit.

For the SRS to operate:

- (1) One or both cowl sensors and one or both dash sensors must activate.
- (2) Electrical energy must be supplied to the airbag inflator by the battery, or by the back-up power circuit if the battery voltage is too low.
- (3) The inflator charge must ignite and deploy the airbag.

It takes about 0.1 second from the beginning of the airbag deployment until it is completely deflated (frontal collision against a fixed wall at a speed of 30 mph [50 km/h]).

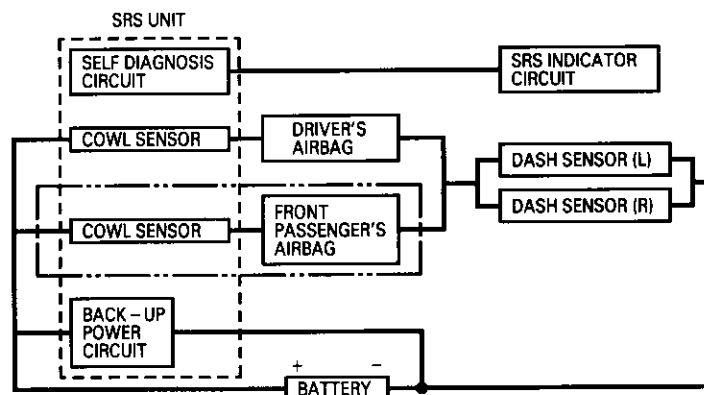

Self-diagnosis system

A self-diagnosis circuit is built into the SRS unit; when the ignition switch is turned ON, the SRS indicator light comes on and goes off after about six seconds if the system is operating normally. If the light does not come on, or does not go off after six seconds, or if it comes on while driving, it indicates an abnormality in the system. The system must be inspected and repaired as soon as possible.

Supplemental Restraint System (SRS)

Circuit Diagram (Without Front Passenger's Airbag)

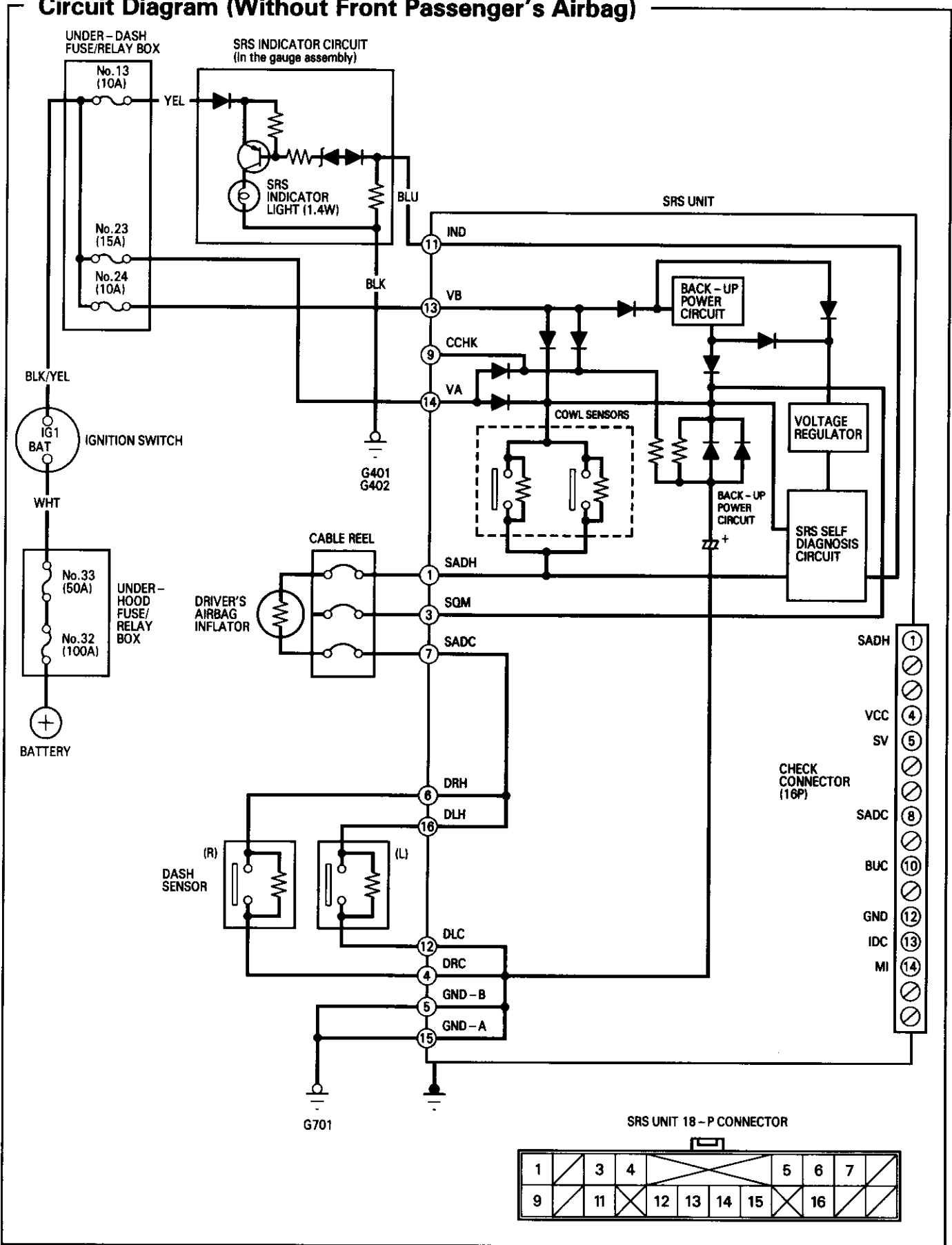



Circuit Diagram (With Front Passenger's Airbag)

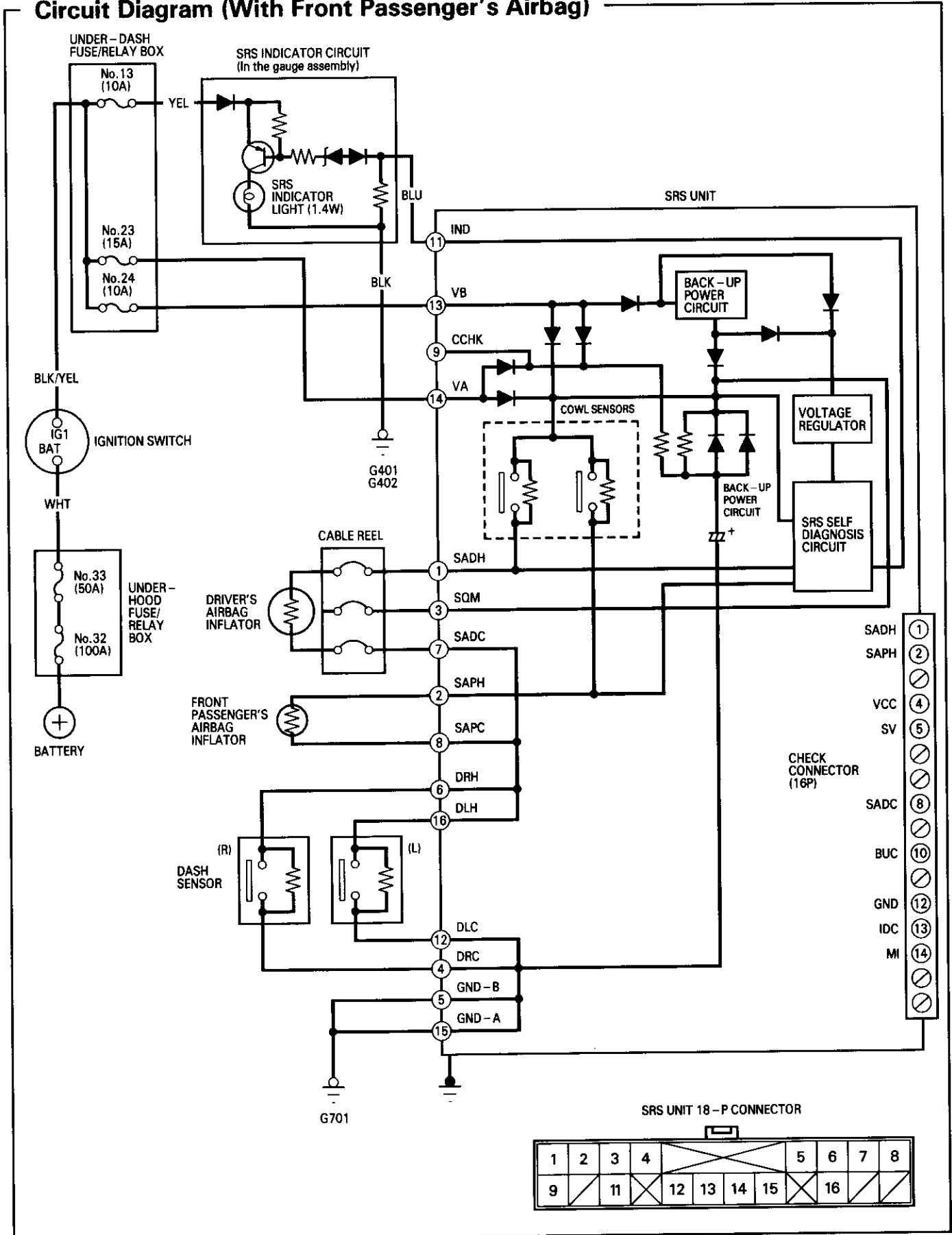

Supplemental Restraint System (SRS)

Wiring Locations

CAUTION: Make sure all SRS ground locations are clean and grounds are securely attached.

NOTE:

- All SRS electrical wiring harnesses are covered with yellow outer insulation.
- Replace the entire affected SRS harness assembly if it has an open circuit or damaged wiring.

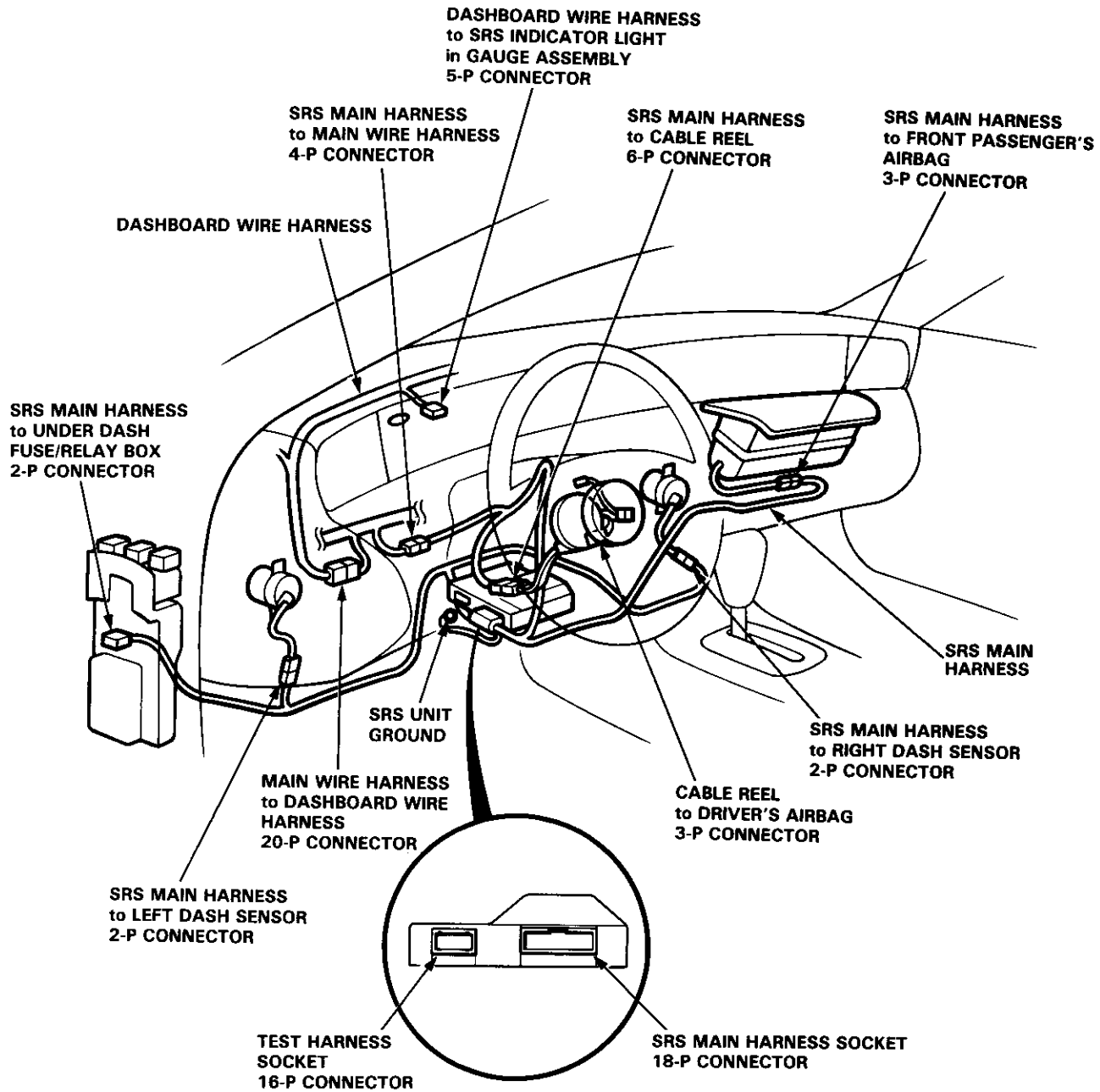

General Precautions

- Carefully inspect any SRS part before you install it. Do not install any part that shows signs of being dropped or improperly handled, such as dents, cracks or deformation:

- Airbag assembly (driver's and front passenger's).
- Dash sensors.
- Cable reel.
- SRS unit.

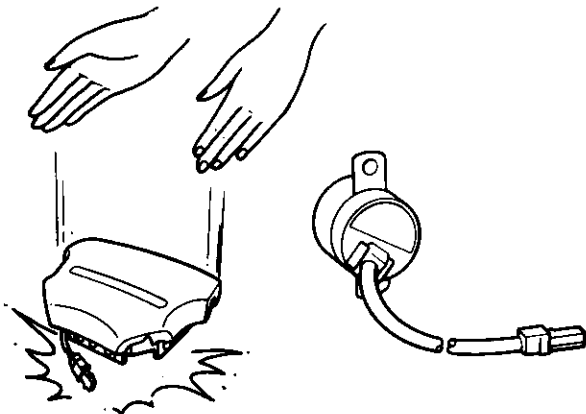

- Use only a digital multimeter (KS-AHM-32-003) to check the system. Using an analog circuit tester may cause an accidental deployment and possible injury.
- Do not install used SRS parts from another car. When making SRS repairs, use only new parts.
- Except when performing electrical inspections, always disconnect both the negative cable and positive cable at the battery before beginning work.
- Replacement of the combination light and wiper/washer switches and cruise control switch can be done without removing the steering wheel:
 - Combination light and wiper/washer switch replacement (see page 23-182).
 - Cruise control switch replacement (see page 23-278).
- When reinstalling the SRS unit cover, be sure it snaps together properly.

Airbag Handling and Storage

Do not try to disassemble the airbag assembly. It has no serviceable parts. Once an airbag has been operated (deployed), it cannot be repaired or reused.

For temporary storage of the airbag assembly during service, please observe the following precautions:

- Store the removed airbag assembly with the pad surface up.

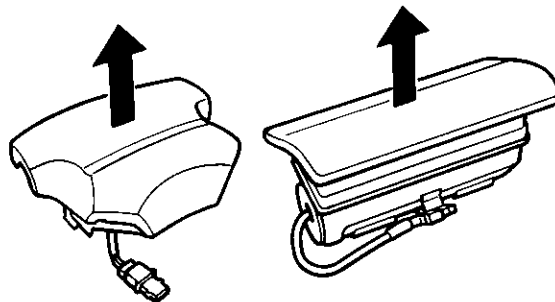

▲ WARNING If the airbag is improperly stored face down, accidental deployment could propel the unit with enough force to cause serious injury.

- Store the removed airbag assembly on a secure flat surface away from any high heat source (exceeding 212°F/100°C) and free of any oil, grease, detergent or water.

CAUTION: Improper handling or storage can internally damage the airbag assembly, making it inoperative.

If you suspect the airbag assembly has been damaged, install a new unit and refer to the Deployment/Disposal Procedures for disposing of the damaged airbag.

Supplemental Restraint System (SRS)

Wiring Precautions

- Never attempt to modify, splice or repair SRS wiring.

NOTE: SRS wiring can be identified by special yellow outer protective covering.

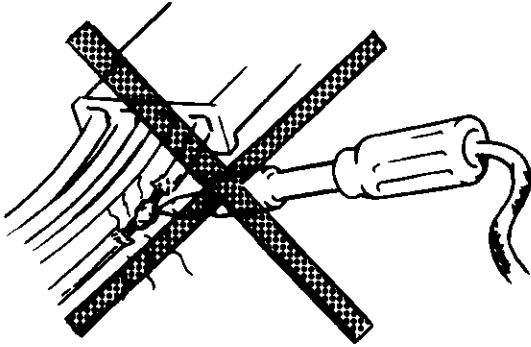

- Be sure to install the harness wires so that they are not pinched or interfering with other car parts.

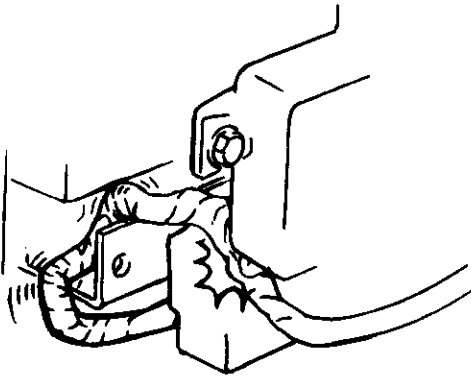

- Make sure all SRS ground locations are clean and grounds are securely fastened for optimum metal-to-metal contact. Poor grounding can cause intermittent problems that are difficult to diagnose.

Installing the short connector

▲ WARNING To avoid accidental deployment and possible injury, always install the protective short connector(s) on the driver's and passenger's airbag connector(s) before working near any SRS wiring.

NOTE: The radio may have a 5-digit coded theft protection circuit. Be sure to get the customer's code number before disconnecting the battery.

1. Disconnect the battery negative cable, then disconnect the positive cable.
2. Install the short connector(s)(RED):

Driver's Side:

- Remove the access panel from the steering wheel, then remove the short connector (RED) from the panel.

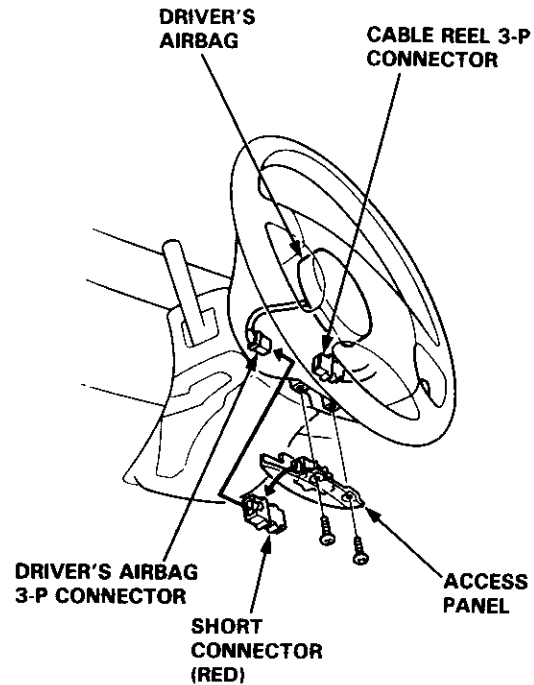

- Disconnect the 3-P connector between the driver's airbag and cable reel, then install the short connector (RED) on the airbag side of the connector.

Front Passenger's Side:

- Remove the glove box, then remove the short connector (RED) from its holder.

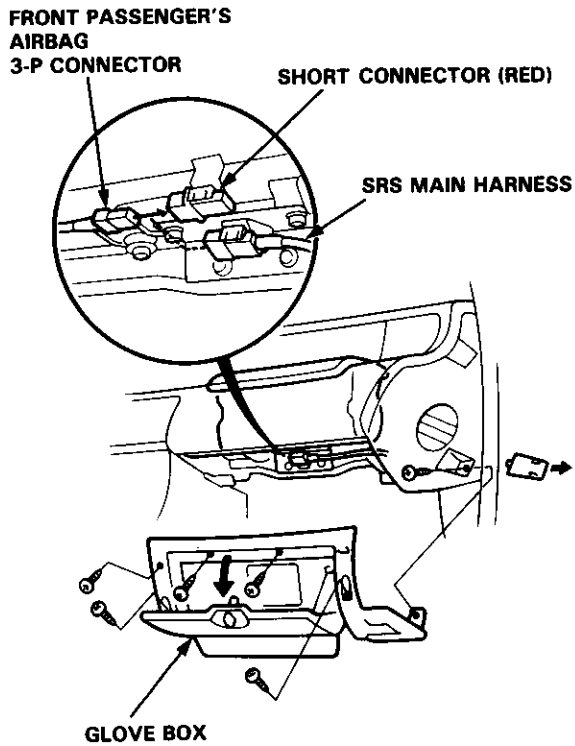

- Disconnect the 3-P connector between the front passenger's airbag and SRS main harness, then install the short connector (RED) on the airbag side of the connector.

Disconnecting the SRS Connector at the Fuse Box

CAUTION: Avoid breaking the connector; it's double-locked.

1. First lift the connector lid with a thin screwdriver, then press the connector tab down and pull the connector out.

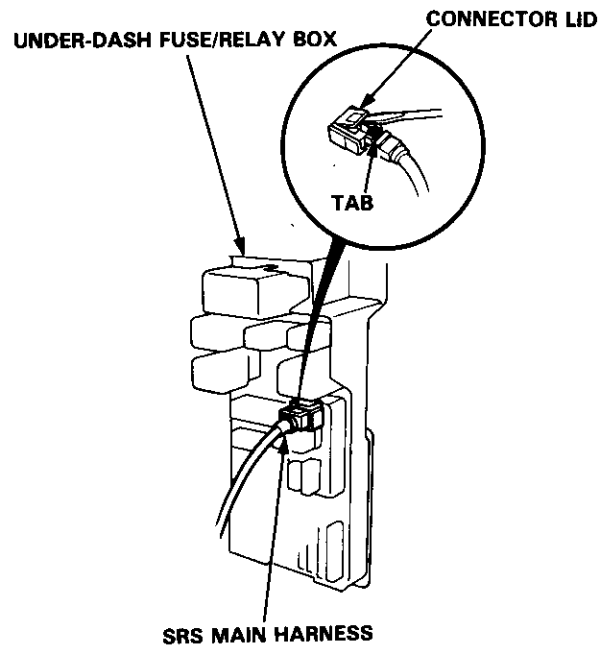

2. To reinstall the connector, push it into position until it clicks, then close its lid.

Supplemental Restraint System (SRS)

Steering-related Precautions

Steering Wheel and Cable Reel Alignment

NOTE: To avoid misalignment of the steering wheel or airbag on reassembly, make sure the wheels are turned straight ahead before removing the steering wheel.

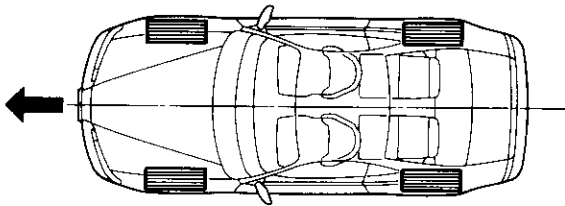

Rotate the cable reel clockwise until it stops. Then rotate it counterclockwise (approximately two turns) until:

- The yellow gear tooth lines up with the alignment mark on the cover.
- The arrow mark on the cable reel label points straight up.

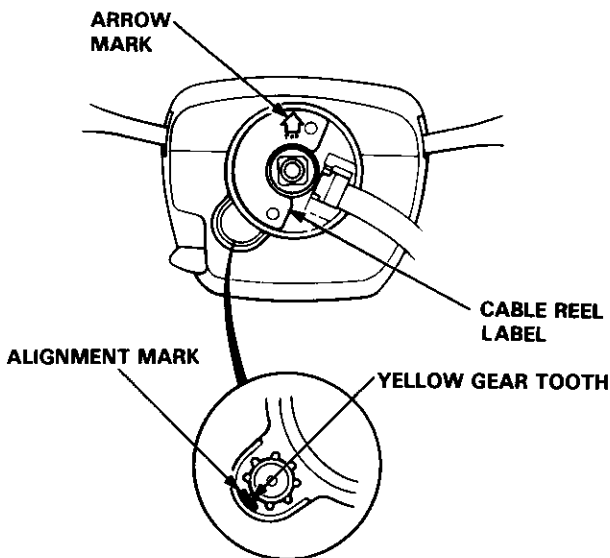

Steering Column Removal

CAUTION:

- Before removing the steering column, first disconnect the connector between the cable reel and the SRS main harness.
- If the steering column is going to be removed without dismounting the steering wheel, lock the steering by turning the ignition key to 0-LOCK position or remove the key from the ignition so that the steering wheel will not turn.

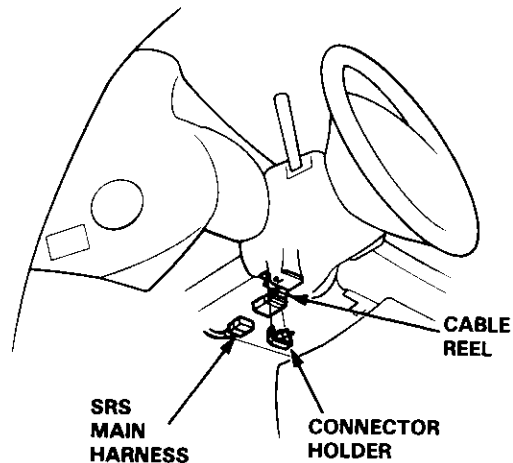

Do not replace the original steering wheel with any other design, since it will make it impossible to properly install the airbag (only use genuine Honda replacement parts).

After reassembly confirm that the wheels are still turned straight ahead and that the steering wheel spoke angle is correct. If minor spoke angle adjustment is necessary, do so only by adjustment of the tie-rods, not by removing and repositioning the steering wheel.

NOTE: Models with 4WS

Test and adjust the 4WS system (see section 17).



Sensor Inspection

CAUTION: Take extra care when painting or doing body work in the area below the dashboard. Avoid direct exposure of the sensors or wiring to heat guns, welding, or spraying equipment.

⚠ WARNING

- Disconnect both the negative and positive battery cables.
- Install the short connector(s) before working below the dashboard or near the dash sensors.
- After any degree of frontal body damage, inspect both dash sensors. Replace a sensor if it is dented, cracked, or deformed.

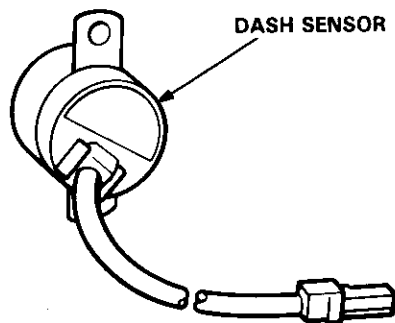

- Be sure the sensors are installed securely.

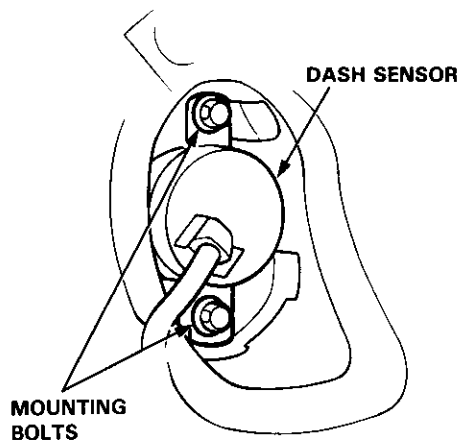

Inspection After Deployment

After a collision in which the airbags were deployed, inspect the following:

1. Inspect the dash sensors for physical damage. If the sensors are damaged, replace them.
2. Inspect all the SRS wire harnesses. Replace, don't repair, any damaged harnesses.
3. Inspect the cable reel for heat damage. If there is any damage, replace the cable reel.
4. After the car is completely repaired, turn the ignition switch on. If the SRS indicator light comes on for about six seconds and then goes off, the SRS system is OK. If the indicator light does not function properly, go to SRS Troubleshooting.

Supplemental Restraint System (SRS)

Troubleshooting

Self-diagnosis Function

The SRS unit includes a self-diagnosis function. If there is a failure in the sensors, SRS unit, inflator, or their circuits, the SRS indicator light in the gauge assembly goes ON.

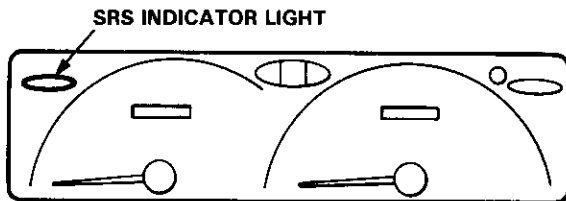

As a system check, the SRS indicator light also comes on when the ignition is first turned to the II position. If the light goes off after approximately six seconds, the system is OK.

If the SRS indicator light remains on (or fails to come on in the system check mode), one of the SRS components (or the wiring/connectors in between) is faulty.

Troubleshooting Precautions

- Always use the test harness. Do not use test probes directly on component connector terminals or wires; you may damage them or the SRS unit.
- When connecting any of the test harnesses to the system, push the connectors straight-in; do not bend the connector terminals.
- Before disconnecting any part of the SRS wire harness, install the short connector (RED) on the driver's airbag. On cars equipped with a front passenger's airbag, install short connectors on the driver's airbag and the front passenger's airbag.

SRS Indicator Light Troubleshooting

Possible conditions:

1. SRS indicator light does not come on at all — see page 23-300.
2. SRS indicator light stays on constantly — see page 23-304.
3. SRS indicator light comes on in combination with a failure of another electrical system (brake system light, malfunction indicator lamp (MIL) etc.). Check for damage/corrosion at the under-dash fuse/relay box connector.

NOTE:

- Before starting the applicable troubleshooting, check the condition of all SRS connectors and ground points.
- If the fault is not found after completing the applicable troubleshooting, substitute a known-good SRS unit and check whether the indicator light goes off.

Short Connector Installation

⚠ WARNING To avoid accidental deployment and possible injury, always install the protective short connector on the driver's airbag connector and on cars equipped with front passenger's airbag, install protective short connectors on the driver's airbag and front passenger's airbag before working near any SRS wiring.

NOTE: The radio may have a 5-digit coded theft protection circuit. Be sure to get the customer's code number before disconnecting the battery.

1. Disconnect the battery negative cable, then disconnect the positive cable.
2. Install the short connector(s):
Driver's Side:
 - Remove the access panel from the steering wheel, then remove the short connector (RED) from the panel.

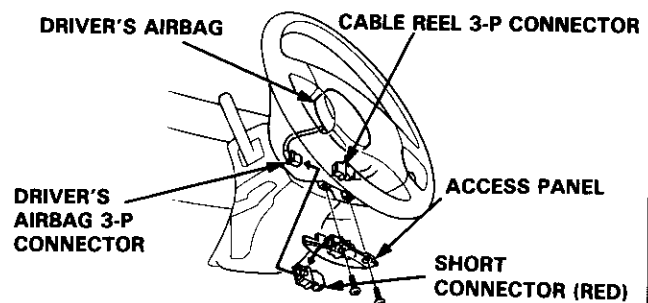

- Disconnect the connector between the driver's airbag and cable reel, then install the short connector (RED) on the airbag side of the connector.

Front Passenger's Side:

- Remove the glove box, then remove the short connector (RED) from the holder.
- Disconnect the connector between the front passenger's airbag and SRS main harness, then install the short connector (RED) on the airbag side of the connector (see page 23-295).



Test Harnesses and Attachment Points

Test Harness A

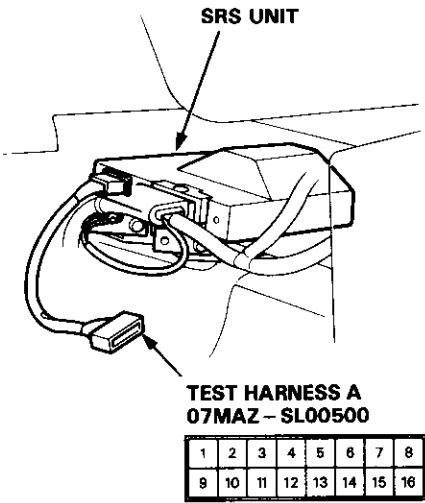

Test Harness B

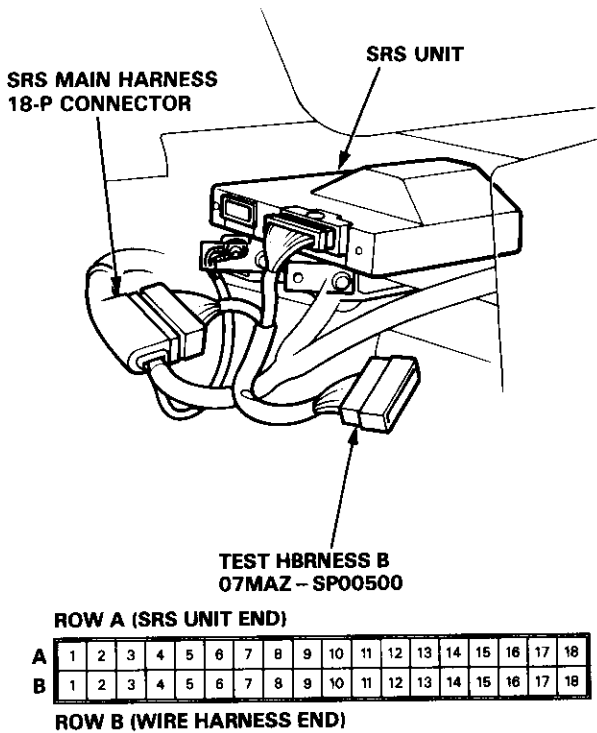

Test Harness C

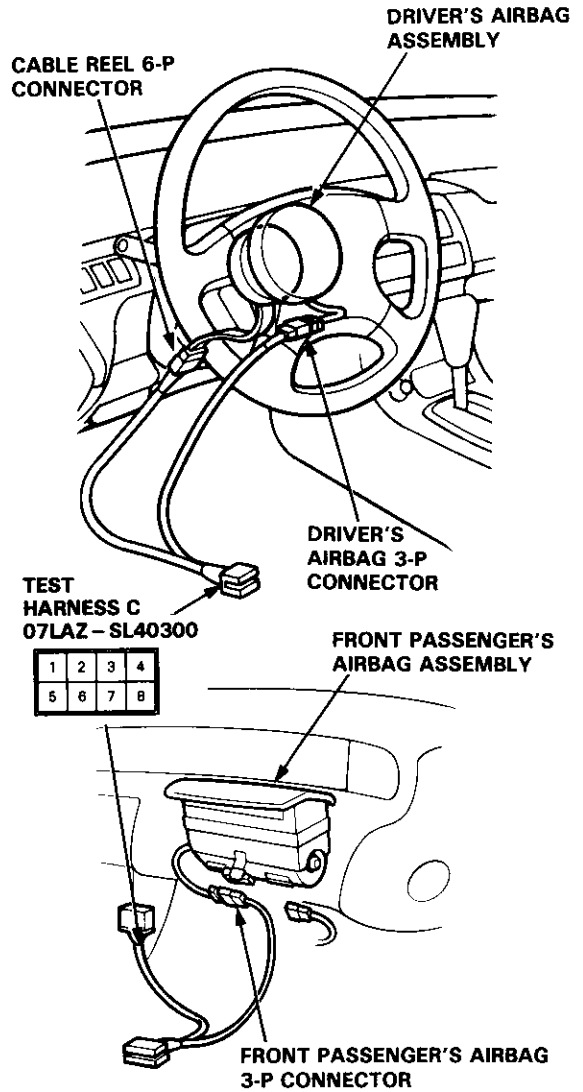

Test Harness D

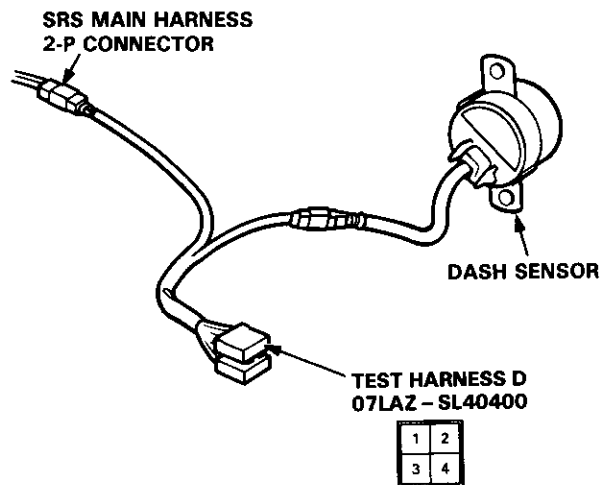

Supplemental Restraint System (SRS)

Troubleshooting

The SRS Indicator Does Not Light

CAUTION: Use only a digital multimeter (KS-AHM-32-003) to check the system.

NOTE: The radio may have a 5-digit coded theft protection circuit. Be sure to get the customer's code number before disconnecting the battery.

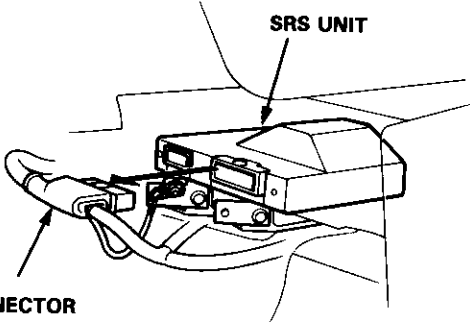
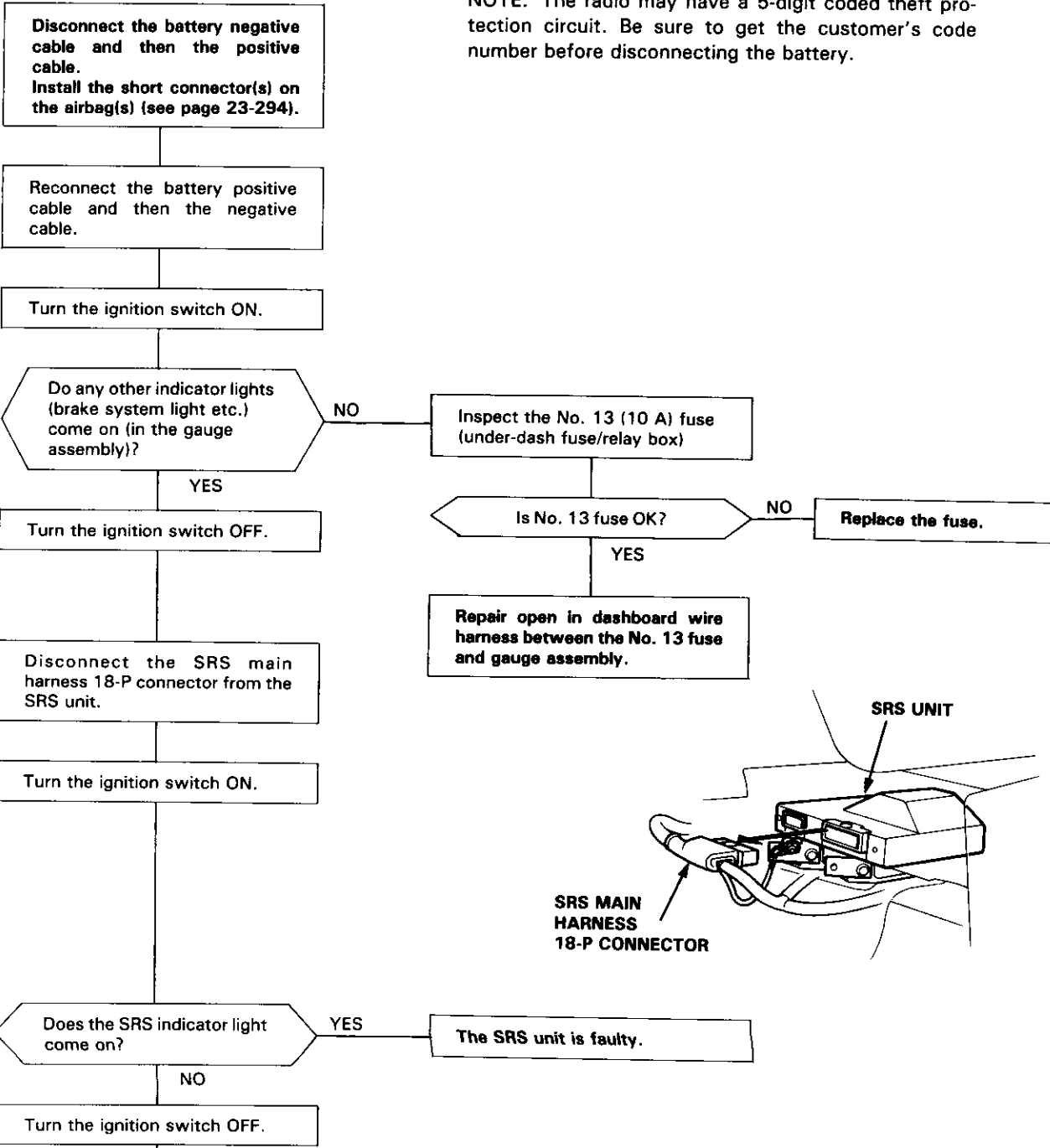

(To page 23-301)

(From page 23-300)

Disconnect the SRS main harness 4-P connector from the main wire harness.

Turn the ignition switch ON.

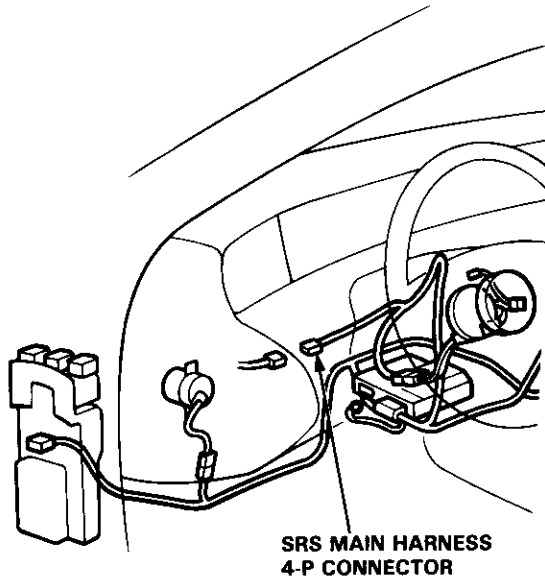

Is SRS indicator light ON?

YES → The SRS main harness is faulty.

NO

Turn the ignition switch OFF.

Remove the gauge assembly, then inspect the SRS indicator light bulb.

Is the SRS indicator light bulb OK?

NO → Replace the indicator light bulb.

YES

Connect a voltmeter between the No. 3 terminal of the 5-P connector and body ground.

Turn the ignition switch ON.

Measure the voltage between the No. 3 terminal and body ground.

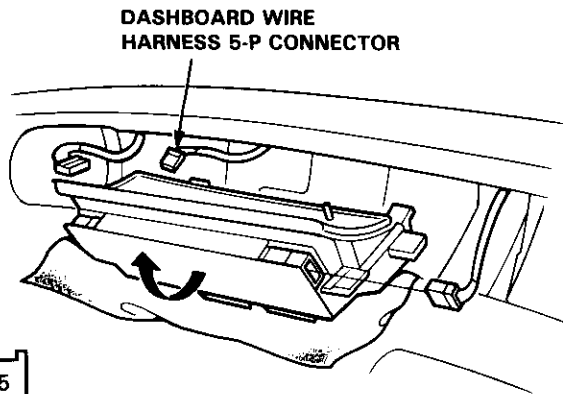

(To page 23-302)

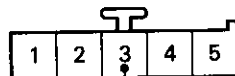

BLU



Less than 8.5V?



View from terminal side.

(cont'd)

Supplemental Restraint System (SRS)

Troubleshooting (cont'd)

(From page 23-301)

Is there less than 8.5 V with the ignition switch ON?

NO

Short in BLU wire of the dashboard wire harness. Replace the dashboard wire harness.

YES

Turn the ignition switch OFF.

Connect the voltmeter between the No. 1 terminal (+) and the No. 5 terminal (-) of the dashboard wire harness 5-P connector.

Turn the ignition switch ON.

Measure the voltage between the No. 1 terminal and the No. 5 terminal.

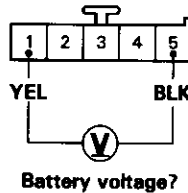
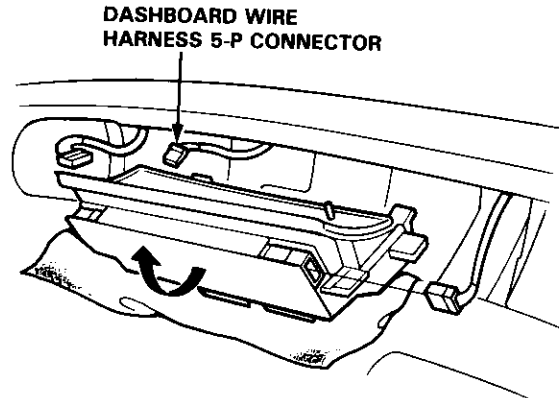

View from terminal side.

Is there battery voltage?

NO

Check for continuity between the No. 5 terminal and body ground.

YES

Turn the ignition switch OFF.

(To page 23-303)

Does continuity exist?

NO

Repair open in the BLK wire (No. 5 terminal) between the gauge assembly and body ground or look for a poor ground (G401, 402).

YES

Repair open in the YEL wire (No. 1 terminal) of the dashboard wire harness between the gauge assembly and the No. 13 fuse.

(From page 23-302)

Reconnect each connector to the gauge assembly and SRS unit then connect Test Harness A to the SRS unit.

Measure the voltage between the No. 13 terminal and body ground for six seconds after ignition is first turned on.

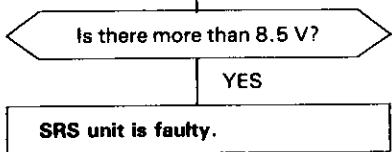
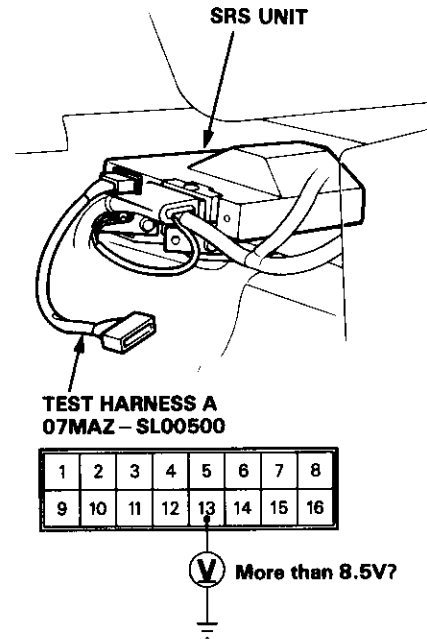

(cont'd)

Supplemental Restraint System (SRS)

Troubleshooting (cont'd)

SRS Indicator Light Stays on Continuously

1. Make a photocopy of this page (without front passenger's airbag), or the next page (with front passenger's airbag).
2. Connect Test Harness A (07MAZ-SL00500) to the SRS unit as shown.
3. Turn the ignition switch ON.
 - Voltages in the chart assume the car's "battery voltage" is about 12 volts. Less than 12 volts will result in different or possibly false readings.
 - Do not disconnect the airbag from the circuit when checking SRS unit voltages.
4. First, check for voltage between Test Harness Terminal No. 12 and ground.
 - If voltage is indicated, there is a poor ground (see page 23-317).
 - If no voltage is indicated, continue with checking all the other terminals.
5. Record your voltage readings, for each terminal, in the row of blank boxes near the top of the chart.

6. Compare each reading with the voltage ranges listed in the column below it. If the reading is within a range, circle that range.

- If you circled all the Failure Mode ranges across any row, check the car for the Probable Failure Mode listed at the end of the row. (Refer to the letter for that Mode on the following pages).

- If you did not circle all the ranges across any row, replace the SRS unit with a known-good unit, and retest.

- If all your voltage readings are now Normal, replace the SRS unit.

- If your voltage readings are still not normal but they don't fit within a complete row of Failure Mode ranges, check the condition of the terminals in each of the SRS connectors shown in the system diagram on page 23-292.

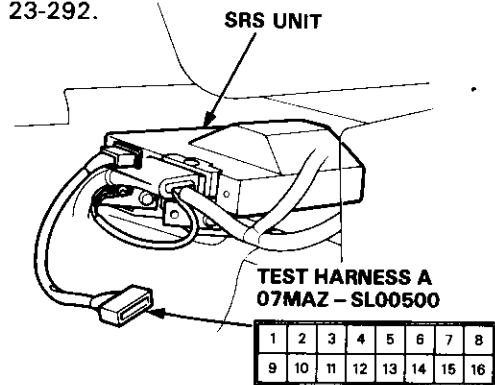

Without Front Passenger's Airbag:

NOTE: Do not disconnect the airbag when checking SRS unit voltages.

Test Harness Terminal	1 SADH	-	-	4 VCC	5 SV	-	-	8 SADC	-	10 BUC1	-	12 GND	13 IDC	14 M1	-	-	Probable Failure Mode	
Normal Voltage	4.3 -5.6	-	-	4.5 -5.5	12.0 -14.3	-	-	5.6 -7.3	-	11.5 -14.5	-	0	8.5 -13.6	8.4 -10.9	-	-		
Your Voltage Reading		-	-			-	-		-		-				-	-		
Failure Mode Voltage	2.8 -3.7	-	-	4.5 -5.5	12.0 -14.3	-	-	3.7 -4.9	-	11.5 -14.5	-	0	2.0 -8.5	8.4 -10.9	-	-	A Open in one cowl sensor.	
	0	-	-	4.5 -5.5	12.0 -14.3	-	-	0	-	11.5 -14.5	-	0	2.0 -8.5	8.4 -10.9	-	-	B • Open in both cowl sensors. • Short in one dash sensor. • Short to driver's airbag inflator.	
	8.6 -11.3	-	-	4.5 -5.5	12.0 -14.3	-	-	11.2 -14.6	-	11.5 -14.5	-	0	2.0 -8.5	8.4 -10.9	-	-	C Short in cowl sensor or open in both dash sensors.	
	5.7 -7.4	-	-	4.5 -5.5	12.0 -14.3	-	-	7.4 -9.7	-	11.5 -14.5	-	0	2.0 -8.5	8.4 -10.9	-	-	D Open in one dash sensor.	
	8.6 -11.3	-	-	4.5 -5.5	12.0 -14.3	-	-	0	-	11.5 -14.5	-	0	2.0 -8.5	8.4 -10.9	-	-	E Open in driver's airbag inflator or cable reel.	
	4.3 -5.6	-	-	0	0	-	-	5.6 -7.3	-	11.5 -14.5	-	0	2.0 -8.5	8.4 -10.9	-	-	H Blown SRS fuse (No. 24 10 A) or open in the wire.	
	4.3 -5.6	-	-	4.5 -5.5	12.0 -14.3	-	-	5.6 -7.3	-	11.5 -14.5	-	0	0 (8.5 -13.6)	8.4 -10.9	-	-	I Short (or open) in SRS indicator wire harness.	



With Front Passenger's Airbag:

NOTE: Do not disconnect the airbag when checking SRS unit voltages.

Test Harness Terminal	1 SADH	2 SAPH	-	4 VCC	5 SV	-	-	8 SADC	-	10 BUC1	-	12 GND	13 IDC	14 M1	-	-	Probable Failure Mode	
Normal Voltage	4.3 -5.6	4.3 -5.6	-	4.5 -5.5	12.0 -14.3	-	-	5.6 -7.3	-	11.5 -14.5	-	0	8.5 -13.6	8.4 -10.9	-	-		
Your Voltage Reading																		
Failure Mode Voltage	2.8 -3.7	2.8 -3.7	-	4.5 -5.5	12.0 -14.3	-	-	3.7 -4.9	-	11.5 -14.5	-	0	2.0 -8.5	8.4 -10.9	-	-	A Open in one cowl sensor.	
	0	0	-	4.5 -5.5	12.0 -14.3	-	-	0	-	11.5 -14.5	-	0	2.0 -8.5	8.4 -10.9	-	-	B • Open in both cowl sensors. • Short in one dash sensor. • Short to driver's or passenger's airbag inflator.	
	8.6 -11.3	8.6 -11.3	-	4.5 -5.5	12.0 -14.3	-	-	11.2 -14.6	-	11.5 -14.5	-	0	2.0 -8.5	8.4 -10.9	-	-	C Short in cowl sensor or open in both dash sensors.	
	5.7 -7.4	5.7 -7.4	-	4.5 -5.5	12.0 -14.3	-	-	7.4 -9.7	-	11.5 -14.5	-	0	2.0 -8.5	8.4 -10.9	-	-	D Open in one dash sensor.	
	8.6 -11.3	2.9 -3.7	-	4.5 -5.5	12.0 -14.3	-	-	3.7 -4.9	-	11.5 -14.5	-	0	2.0 -8.5	8.4 -10.9	-	-	E Open in driver's airbag inflator or cable reel.	
	2.9 -3.7	8.7 -11.2	-	4.5 -5.5	12.0 -14.3	-	-	3.7 -4.9	-	11.5 -14.5	-	0	2.0 -8.5	8.4 -10.9	-	-	F Open in front passenger's airbag inflator.	
	8.6 -11.3	8.6 -11.3	-	4.5 -5.5	12.0 -14.3	-	-	0	-	11.5 -14.5	-	0	2.0 -8.5	8.4 -10.9	-	-	G Open in driver's and passenger's airbag inflator.	
	4.3 -5.6	4.3 -5.6	-	0	0	-	-	5.6 -7.3	-	11.5 -14.5	-	0	2.0 -8.5	8.4 -10.9	-	-	H Blown SRS fuse (No. 24 10 A) or open in the wire.	
	4.3 -5.6	4.3 -5.6	-	4.5 -5.5	12.0 -14.3	-	-	5.6 -7.3	-	11.5 -14.5	-	0	0 (8.5 -13.6)	8.4 -10.9	-	-	I Short (or open) in SRS indicator wire harness.	

Supplemental Restraint System (SRS)

Troubleshooting (cont'd)

Mode A: Open in one cowl sensor.

- The SRS unit is faulty. Substitute a known-good SRS unit and recheck the voltages according to the chart on page 23-304.

Mode B:

- Short to driver's or passenger's airbag inflator.
- Short in one dash sensor.
- Open in both cowl sensor.

NOTE: The radio may have a 5-digit coded theft protection circuit. Be sure to get the customer's code number before disconnecting the battery cables.

1. Before disconnecting any part of the SRS wire harness, install the short connector(s) (RED) on the airbag(s) (see page 23-294).
2. Connect Test Harness B (07MAZ-SPO0500) between the SRS unit and SRS main harness 18-P connector.

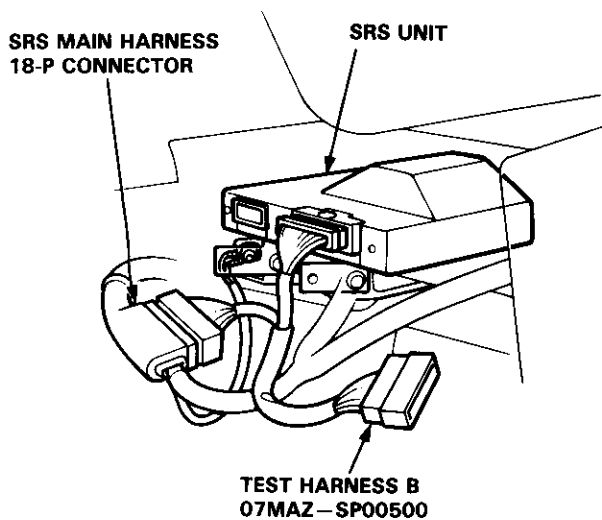

3. Reconnect the driver's airbag connector, then check continuity between the B1 terminal and body ground, and between the B7 terminal and body ground.

TEST HARNESS B 07MAZ-SPO0500

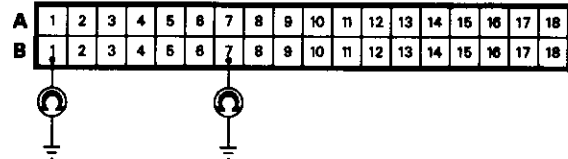

- If there is continuity at either terminal, go to step 6.
 - If there is no continuity at either terminal, go to step 4.
4. Reconnect the front passenger's airbag connector, then check continuity between the B2 terminal and body ground, and between the B8 terminal and body ground.

TEST HARNESS B 07MAZ-SPO0500

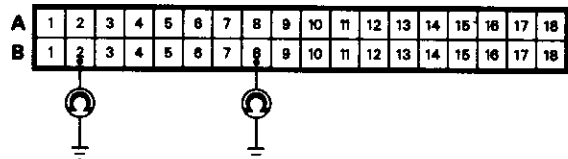

- If there is continuity at either terminal, go to step 10.
- If there is no continuity at either terminal, go to step 5.

5. Check continuity between body ground and each terminal of both dash sensors.

**TEST HARNESS B
07MAZ - SPO0500**

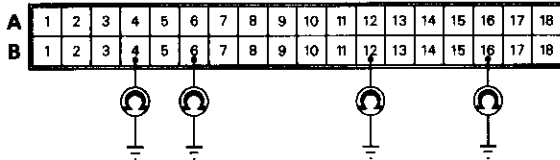

- If there is continuity at any of the terminals, go to step 12.
- If there is no continuity at any terminal, go to step 13.

6. Disconnect the cable reel 6-P connector from the SRS main harness, then connect Test Harness C (07LAZ - SL40300) only to the cable reel side of the 6-P connector.

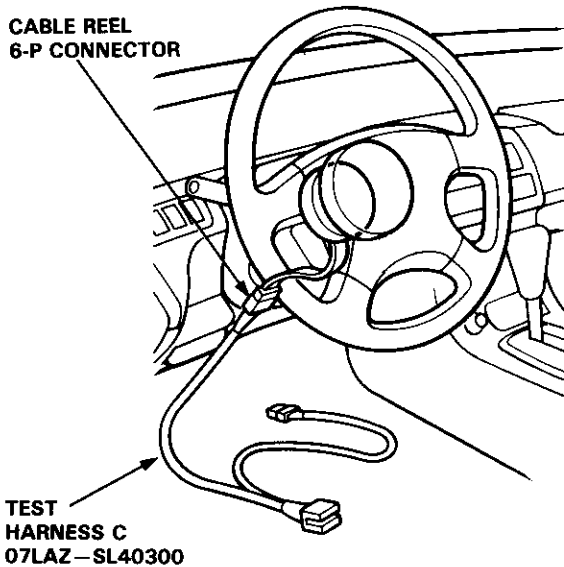

7. Check continuity between the No. 4 terminal and body ground, and between the No. 5 terminal and body ground.

**TEST HARNESS C
07LAZ - SL40300**

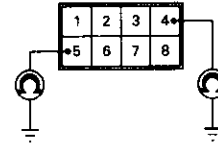

- If there is continuity at either terminal, go to step 8.
- If there is no continuity at either terminal, the SRS main harness is faulty. Replace it and recheck the voltages according to the chart on page 23-304.

(cont'd)

Supplemental Restraint System (SRS)

Troubleshooting (cont'd)

8. Disconnect the driver's airbag 3-P connector from the cable reel, then connect Test Harness C (07LAZ-SL40300) to the driver's airbag 3-P connector.

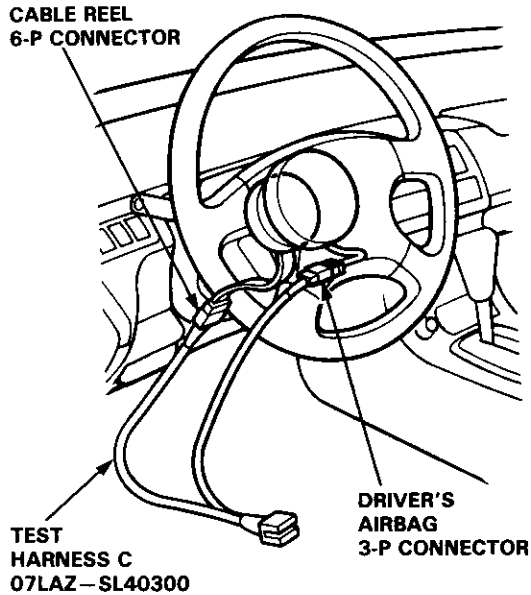

9. Check continuity between the No. 7 terminal and body ground, and between the No. 8 terminal and body ground.

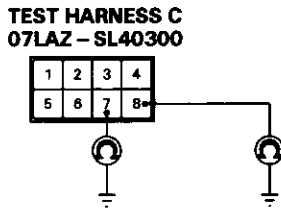

- If there is continuity at either terminal, the driver's airbag inflator is faulty. Replace it and recheck the voltages according to the chart on page 23-304.
- If there is no continuity at either terminal, the cable reel is faulty. Replace it and recheck the voltages according to the chart on page 23-304.

10. Disconnect the front passenger's airbag 3-P connector from the SRS main harness, then connect Test Harness C (07LAZ-SL40300) to the airbag side of the connector.

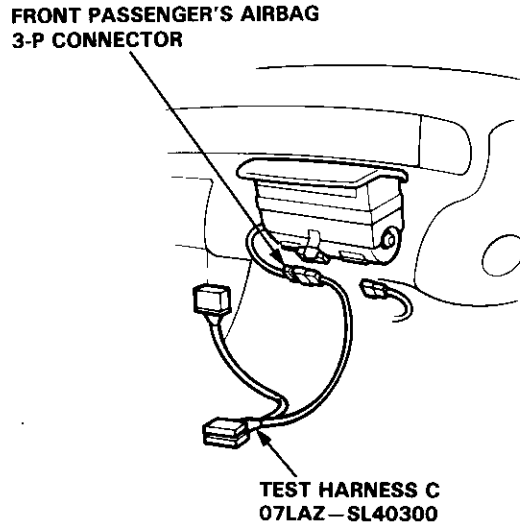

11. Check continuity between the No. 7 terminal and body ground, and between the No. 8 terminal and body ground.

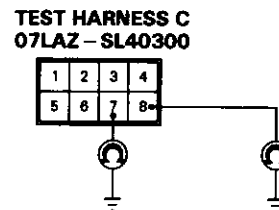

- If there is continuity at either terminal, the front passenger's airbag inflator is faulty. Replace it and recheck the voltages according to the chart on page 23-304.
- If there is no continuity at either terminal, the SRS main harness is faulty. Replace it and recheck the voltages according to the chart on page 23-304.

12. Connect Test Harness D (07LAZ-SL40400) between the dash sensor and SRS main harness 2-P connector. Check continuity between the No.1 terminal and body ground, and between the No.2 terminal and body ground.

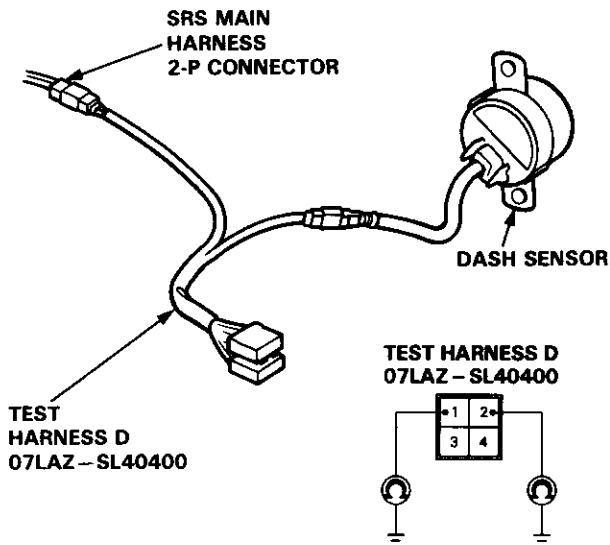

- If there is continuity at either terminal, the dash sensor is faulty. Replace it and recheck the voltages according to the chart on page 23-304.
- If there is no continuity at either terminal, the SRS main harness is faulty. Replace it and recheck the voltages according to the chart on page 23-304.

13. Check the resistance between the left dash sensor terminals B12 and B16, and between the right dash sensor terminals B4 and B6.

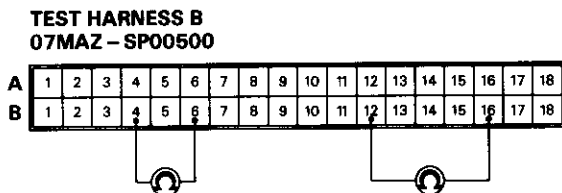

- If resistance is 3.8–4.2 K Ω for both sensors, the SRS unit is faulty. Substitute a know-good SRS unit and recheck the voltages according to the chart on page 23-304.

- If resistance is less than 3.8 K Ω for either sensor, go to step 14.

14. Connect Test Harness D (07LAZ-SL40400) between the dash sensor and SRS main harness 2-P connector. Check the resistance between the No.1 terminal and No. 2 terminal.

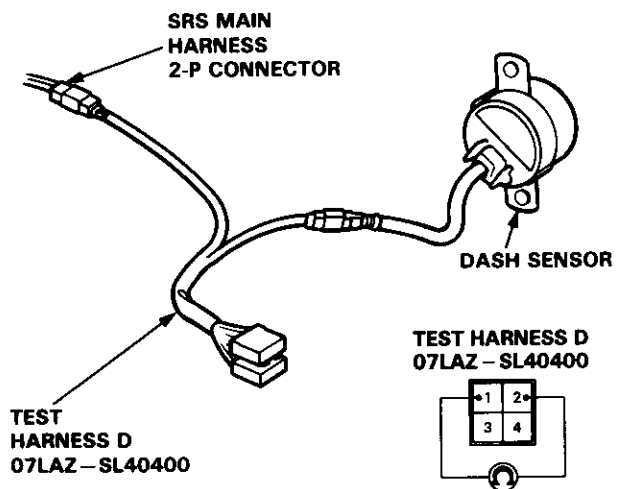

- If resistance is 3.8–4.2 K Ω , the SRS main harness is faulty. Replace it and recheck the voltages according to the chart on page 23-304.

- If resistance is less than 3.8 K Ω , the dash sensor is faulty. Replace it and recheck the voltages according to the chart on page 23-304.

(cont'd)

Supplemental Restraint System (SRS)

Troubleshooting (cont'd)

Mode C: Short in cowl sensor, or open in both dash sensors.

Mode D: Open in one dash sensor.

NOTE: The radio may have a 5-digit coded theft protection circuit. Be sure to get the customer's code number before disconnecting the battery cables.

1. Before disconnecting any part of the SRS wire harness, install the short connector(s) (RED) on the airbag(s) (see page 23-294).
2. Connect Test Harness B (07MAZ-SP00500) between the SRS unit and SRS main harness 18-P connector.

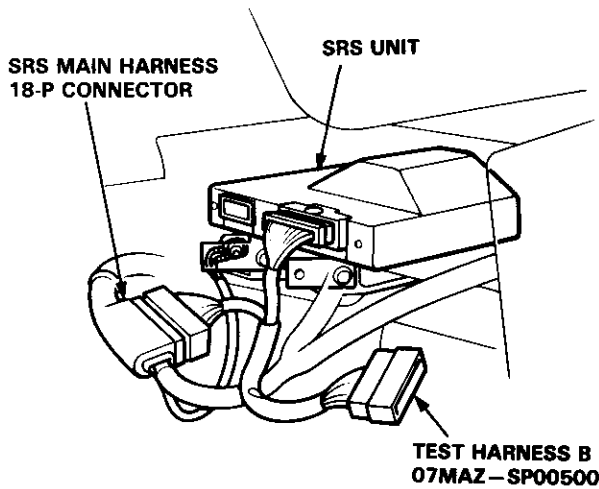

3. Check the resistance between the left dash sensor terminals B12 and B16, and between the right dash sensor terminals B4 and B6.

**TEST HARNESS B
07MAZ-SP00500**

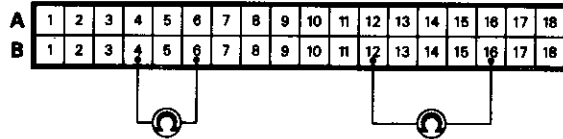

- If resistance is more than 5 K Ω for either set of terminals, go to step 4.
- If resistance is less than 5 K Ω for both sets of terminal, the SRS unit is faulty. Substitute a known-good SRS unit and recheck the voltages according to the chart on page 23-304.



4. Connect Test Harness D (07LAZ-SL40400) between the dash sensor and SRS main harness 2-P connector.
Check the resistance between the No. 1 terminal and No. 2 terminal.

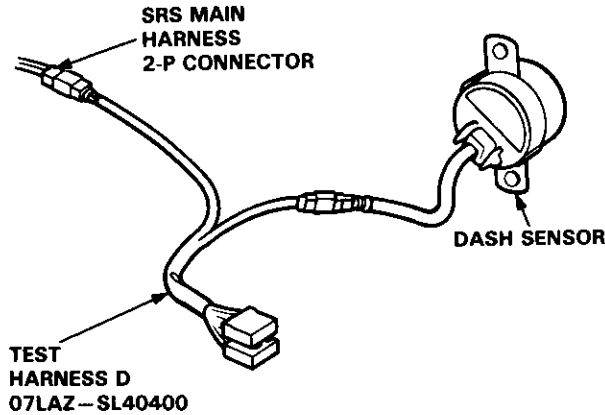

TEST HARNESS D
07LAZ-SL40400

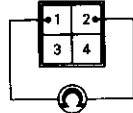

- If resistance is more than 5 K Ω , the dash sensor is faulty. Replace it and recheck the voltages according to the chart on page 23-304.
- If resistance is less than 5 K Ω , the SRS main harness is faulty. Replace the SRS main harness and recheck the voltages according to the chart on page 23-304.

Mode E: Open in driver's airbag inflator or cable reel.

NOTE: The radio may have a 5-digit coded theft protection circuit. Be sure to get the customer's code number before disconnecting the battery cables.

1. Before disconnecting any part of the SRS wire harness, the positive cable. Install the short connector(s) (RED) on the airbag(s) (see page 23-294).
2. Connect Test Harness B (07MAZ-SP00500) between the SRS unit and SRS main harness 18-P connector.

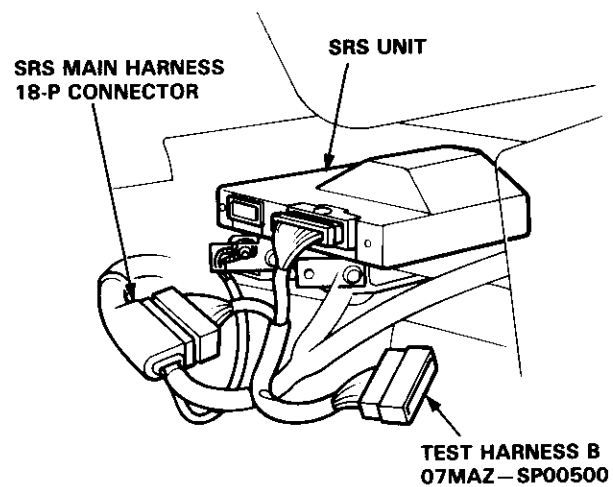

3. Reconnect the driver's airbag connector, then check the resistance between the B1 and the B7 terminals.

TEST HARNESS B
07MAZ-SP00500

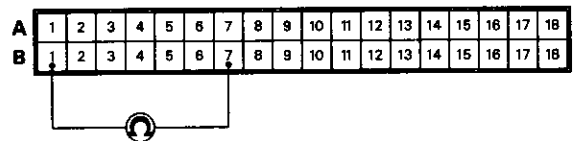

- If resistance is more than 0.2 K Ω , go to step 4.
- If resistance is less than 0.2 K Ω , the SRS unit is faulty. Substitute a known-good SRS unit and recheck the voltages according to the chart on page 23-304.

(cont'd)

Supplemental Restraint System (SRS)

Troubleshooting (cont'd)

4. Disconnect the cable reel 6-P connector from the SRS main harness, then connect Test Harness C (07LAZ-SL40300) only to the cable reel side of the connector.

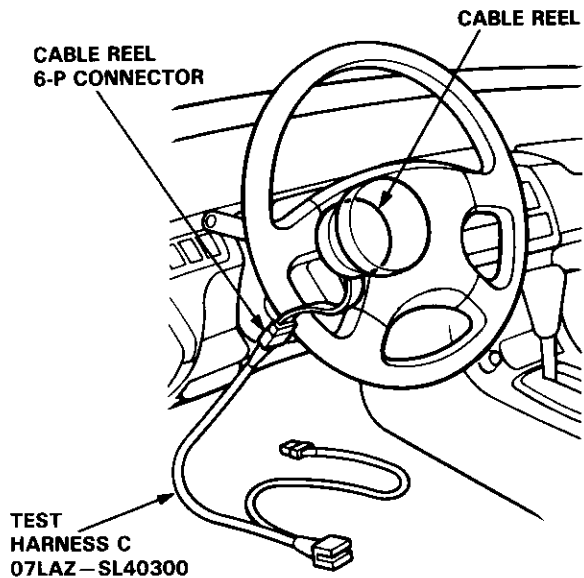

5. Measure the resistance between the No. 4 terminal and the No. 5 terminal.

TEST HARNESS C
07LAZ-SL40300

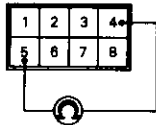

- If resistance is more than 0.2 K Ω , go to step 6.
- If resistance is less than 0.2 K Ω , the SRS main harness is faulty. Replace it and recheck the voltages according to the chart on page 23-304.

6. Disconnect the driver's airbag 3-P connector from the cable reel harness, then connect Test Harness C (07LAZ-SL40300) to the driver's airbag 3-P connector.

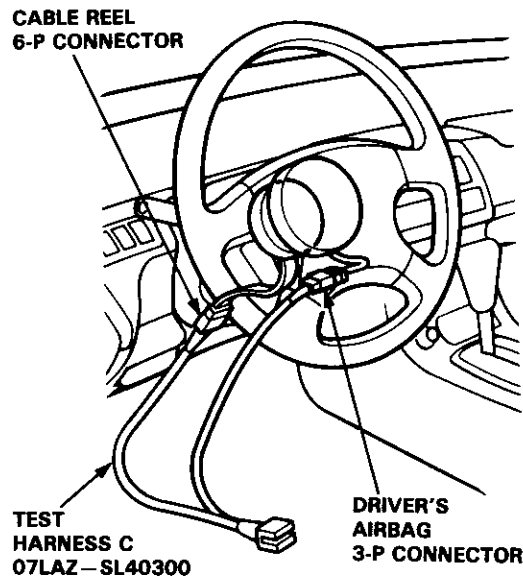

7. Measure the resistance between the No. 7 terminal and the No. 8 terminal.

TEST HARNESS C
07LAZ-SL40300

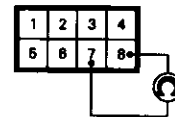

- If resistance is more than 0.2 K Ω , the driver's airbag inflator is faulty. Replace the airbag assembly and recheck the voltages according to the chart on page 23-304.
- If resistance is less than 0.2 K Ω , the cable reel is faulty. Replace it and recheck the voltages according to the chart on page 23-304.



Mode F: Open in front passenger's airbag inflator.

NOTE: The radio may have a 5-digit coded theft protection circuit. Be sure to get the customer's code number before disconnecting the battery cables.

1. Before disconnecting any part of the SRS wire harness, install the short connector(s) (RED) on the airbag(s) (see page 23-294).
2. Connect Test Harness B (07MAZ-SP00500) between the SRS unit and SRS main harness 18-P connector.
3. Reconnect the front passenger's airbag connector, then measure the resistance between the B2 terminal and B8 terminal.

**TEST HARNESS B
07MAZ-SP00500**

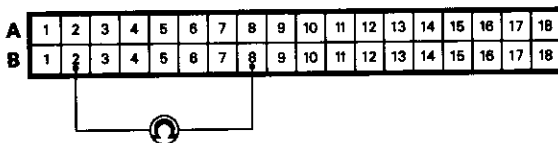

- If resistance is more than 0.2 KΩ, go to step 4.
- If resistance is less than 0.2 KΩ, the SRS unit is faulty. Substitute a known-good SRS unit and recheck the voltages according to the chart on page 23-305.

4. Disconnect the front passenger's airbag 3-P connector from the SRS main harness, then connect Test Harness C (07LAZ-SL40300) to the front passenger's airbag side of the connector.

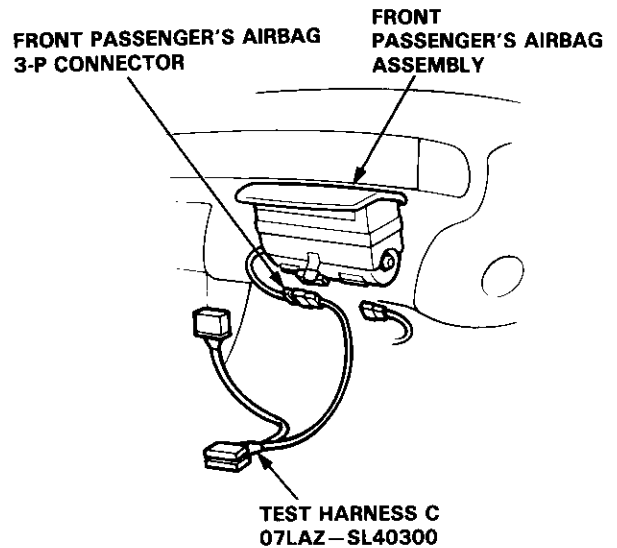

5. Measure the resistance between the No. 7 terminal and the No. 8 terminal.

**TEST HARNESS C
07LAZ-SL40300**

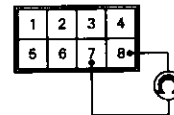

- If resistance is more than 0.2 KΩ, the front passenger's airbag inflator is faulty. Replace the front passenger's airbag assembly and recheck the voltages according to the chart on page 23-305.
- If resistance is less than 0.2 KΩ, the cable reel is faulty. Replace the cable reel and recheck the voltages according to the chart on page 23-305.

(cont'd)

Supplemental Restraint System (SRS)

Troubleshooting (cont'd)

Mode G: Blown SRS No. 24 fuse, or open in the wire.

NOTE: The radio may have a 5-digit coded theft protection circuit. Be sure to get the customer's code number before disconnecting the battery cables.

1. Check the SRS No. 24 (10 A) fuse in the underdash fuse/relay box. If it's OK, go on to step 2. If it's blown, replace it with a new 10 A fuse, then turn the ignition switch ON:

- If fuse doesn't blow, go on to step 2.
- If the fuse blows, troubleshoot as necessary to find the short.

2. Before disconnecting any part of the SRS wire harness, install the short connector(s) (RED) on the airbag(s) (see page 23-294).

3. Connect Test Harness B (07MAZ-SP00500) between the SRS unit and SRS main harness 18-P connector.

SRS MAIN HARNESS
18-P CONNECTOR

SRS UNIT

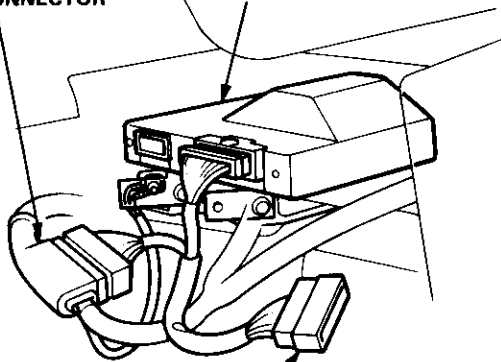

TEST HARNESS B
07MAZ-SP00500

4. Reconnect the positive and negative cables to the battery.

5. Measure the voltage between the B13 terminal and body ground with the ignition switch ON.

TEST HARNESS B
07MAZ-SP00500

A	1	2	3	4	5	6	7	8	9	10	11	12	13	14	15	16	17	18
B	1	2	3	4	5	6	7	8	9	10	11	12	13	14	15	16	17	18



● If there is battery voltage, the SRS unit is faulty. Replace it and recheck the voltages according to the chart on page 23-304.

● If less than battery voltage, the SRS main harness is faulty. Replace it and recheck the voltages according to the chart on page 23-304.

Mode H: Short or open SRS indicator wire harness.

NOTE: The radio may have a 5-digit coded theft protection circuit. Be sure to get the customer's code number before disconnecting the battery cables.

1. Disconnect the SRS main harness 4-P connector from the main wire harness.

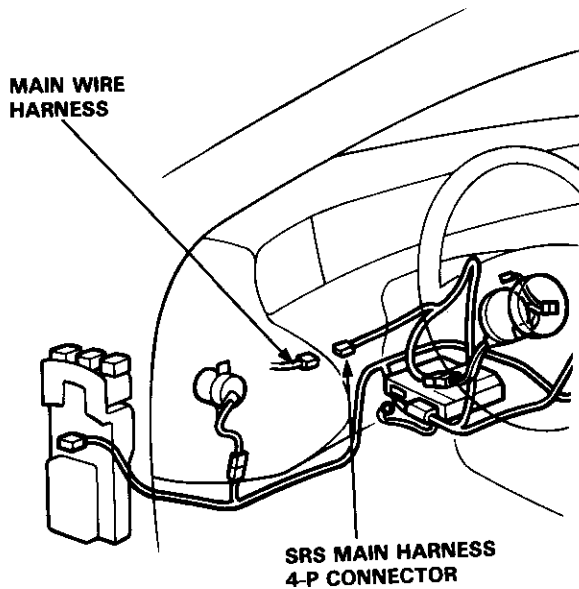

2. Turn the ignition switch ON and wait for six seconds. Measure the voltage between the No. 1 terminal and body ground on the SRS main harness 4-P connector side.

SRS MAIN HARNESS 4-P CONNECTOR

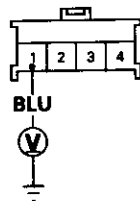

View from terminal side.

- If voltage is more than 8.5 V, go to step 8.
- If voltage is less than 8.5 V, go to step 3.

3. Before disconnecting any part of the SRS wire harness, install the short connector(s) (RED) on the airbag(s) (see page 23-294).
4. Connect Test Harness B (07MAZ-SP00500) between the SRS unit and SRS main harness 18-P connector.

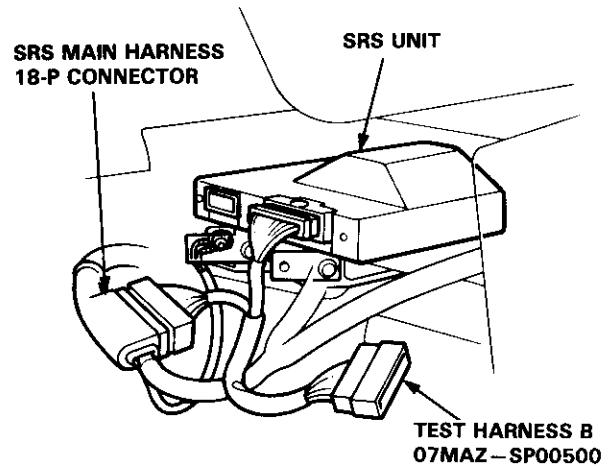

5. Reconnect the battery positive cable and negative cable.
6. Check for continuity between the B11 terminal and body ground.

TEST HARNESS B 07MAZ-SP00500

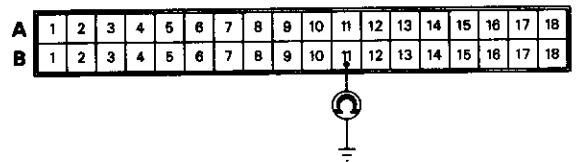

- If there is continuity, the SRS main harness is shorted. Replace the SRS main harness and recheck the voltages according to the chart on page 23-304.
- If there is no continuity, go to step 7.

(cont'd)

Supplemental Restraint System (SRS)

Troubleshooting (cont'd)

7. Check for continuity between the B11 terminal of Test Harness B (07MAZ-SPO0500) and the No. 1 terminal of the SRS main harness 4-P connector.

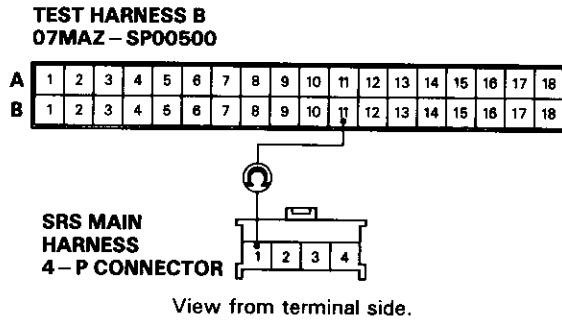

- If there is continuity, the SRS unit is faulty. Replace it and recheck the voltages according to the chart on page 23-304.
 - If there is no continuity, there is an open in the SRS main harness. Replace the SRS main harness and recheck the voltages according to the chart on page 23-304.
8. Reconnect the SRS main harness 4-P connector to the main wire harness. Disconnect the dashboard wire harness 5-P connector from the gauge assembly.

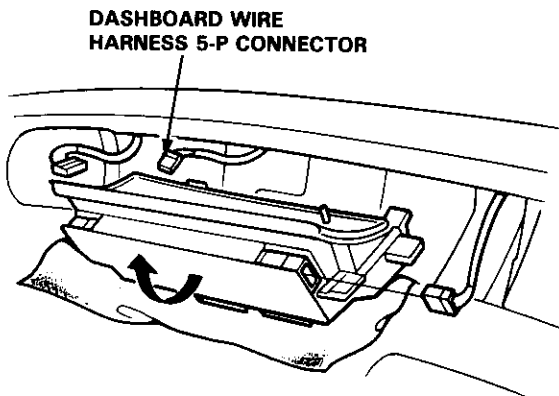

9. Turn the ignition switch ON and wait for six seconds. Measure the voltage between the No. 5 terminal and body ground.

DASHBOARD WIRE HARNESS 5-P CONNECTOR

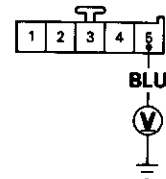

- If voltage is more than 8.5 V, the SRS indicator circuit is faulty (in the gauge assembly). Replace the SRS indicator assembly and recheck the voltages according to the chart on page 23-304.
- If voltage is less than 8.5 V, the dashboard wire harness (or the main wire harness) is faulty. Replace it and recheck the voltages according to the chart on page 23-304.



Poor ground at SRS unit or unit mounting bolts.

NOTE: The radio may have a 5-digit coded theft protection circuit. Be sure to get the customer's code number before disconnecting the battery cables.

1. Before disconnecting any part of the SRS wire harness, install the short connector(s) (RED) on the airbag(s) (see page 23-294).
2. Connect Test Harness B (07MAZ-SP00500) between the SRS unit and SRS main harness 18-P connector.

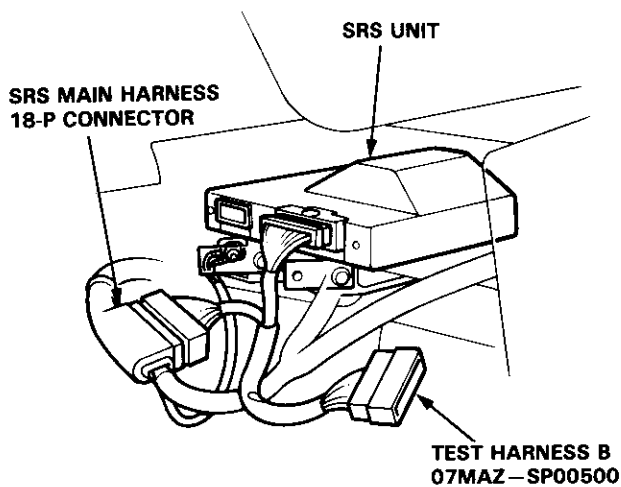

3. Check for continuity between the B5 terminal and body ground, and the B15 terminal and body ground.

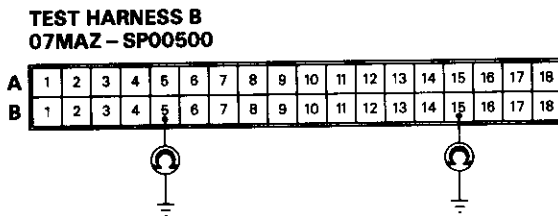

- If there is continuity at either terminal, the SRS unit is faulty. Replace it and recheck the voltages according to the chart on page 23-304.
- If there is no continuity at either terminal, the SRS unit ground, the SRS unit component grounds, or the SRS main harness is faulty. Check the grounds (check the SRS unit ground wire and mounting bolts) and, if necessary, replace the SRS main harness. Recheck the voltages according to the chart on page 23-304.

Supplemental Restraint System (SRS)

Airbag Assembly Replacement

⚠ WARNING Store a removed airbag assembly with the pad surface up. If the airbag is improperly stored face down, accidental deployment could propel the unit with enough force to cause serious injury.

CAUTION:

- Do not install used SRS parts from another car. When repairing as SRS, use only new parts.
- Carefully inspect the airbag assembly before you install it. Do not install an airbag assembly that shows signs of being dropped or improperly handled, such as dents, cracks or deformation.
- Always keep the short connector(s) (RED) on the airbag(s) when the harness is disconnected.
- Do not disassemble or tamper with the airbag assembly.

NOTE: The radio may have a 5-digit coded theft protection circuit. Be sure to get the customer's code number before disconnecting the battery cables.

1. Disconnect the battery negative cable, then disconnect the positive cable.
2. Install the short connector(s) (RED) on the airbag side of the connector(s):

Driver's Side:

- Remove the access panel from the steering wheel, then remove the short connector (RED) from the panel.
- Disconnect the 3-P connector between the driver's airbag and cable reel, then install the short connector (RED) on the airbag side of the connector.

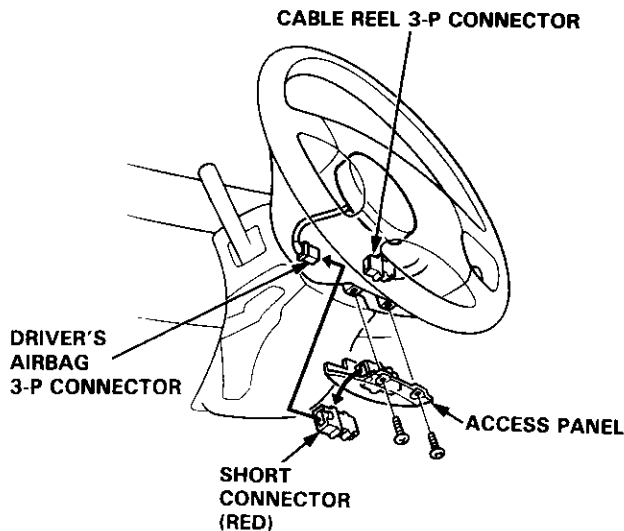

Front Passenger's Side:

- Remove the glove box, then remove the short connector (RED) from its holder.
- Disconnect the 3-P connector between the front passenger's airbag and SRS main harness, then install the short connector (RED) on the airbag side of the connector.

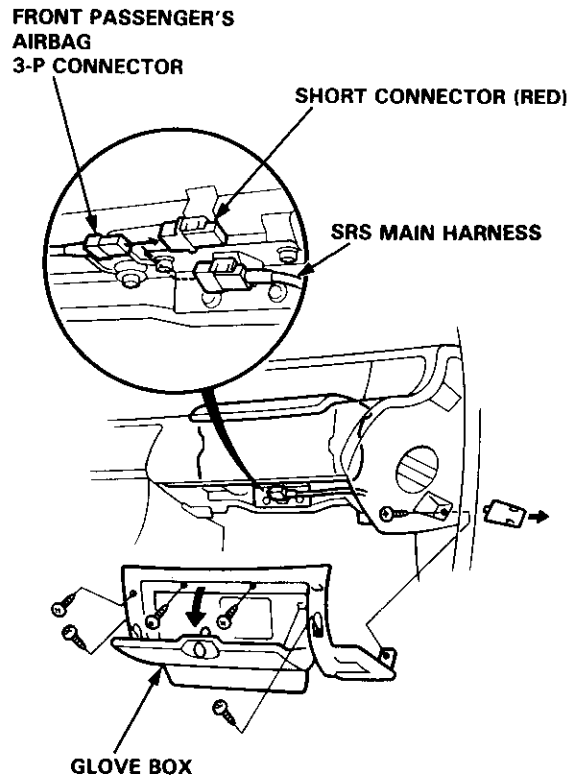

3. Remove the airbag(s):

Driver's Side:

- Remove the two TORX® bolts using a TORX® T30 bit, then remove the driver's airbag assembly.

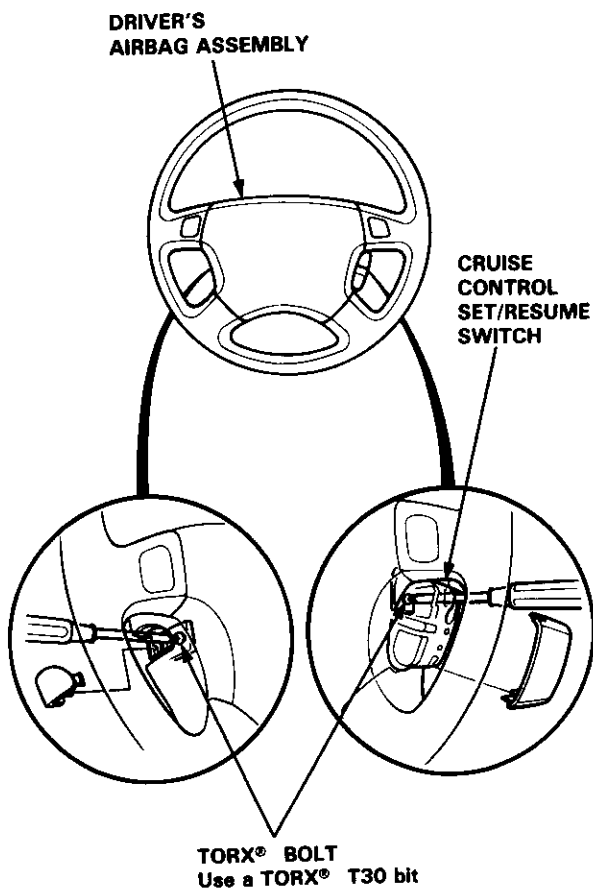

Front Passenger's Side:

- Remove the tweeter cover from the dashboard, then remove the visor and black face panel (see page 23-130).
- Remove the glove box, then remove the four mounting nuts from the front passenger's airbag assembly.

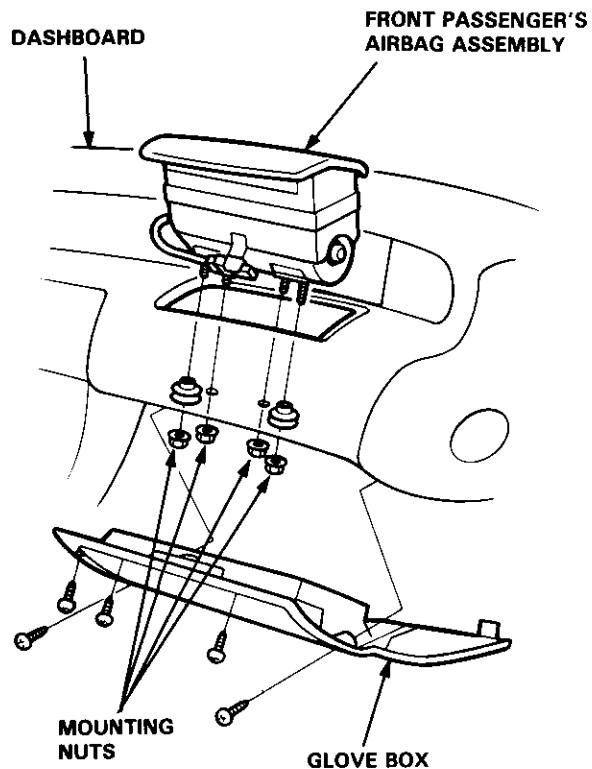

- Carefully lift the front passenger's airbag assembly out of the dashboard.

(cont'd)

Supplemental Restraint System (SRS)

Airbag Assembly Replacement (cont'd)

CAUTION: Be sure to install the SRS wiring so that it is not pinched or interfering with other car parts.

4. Install the new airbag(s).

Driver's Side: Place the driver's airbag assembly in the steering wheel, and secure it with new TORX® bolts.

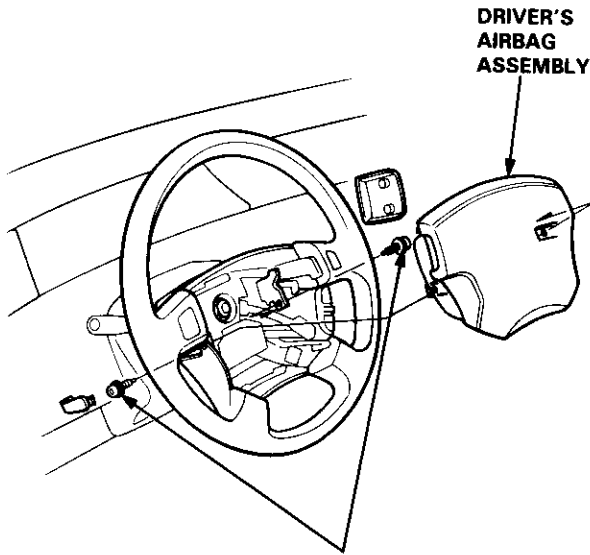

TORX® BOLT
10 N·m (1.0 kg-m, 7.2 lb-ft)
Replace.
Use a TORX® T30 bit

Front Passenger's Side:

- Place the front passenger's airbag assembly in the dashboard.
- Loosen the two mounting nuts on the L-bracket.
- Press the airbag assembly downwards and turn the adjusting nuts until they touch the lower part of the airbag assembly.
- Tighten the four airbag mounting nuts, then tighten the two mounting nuts on the L-bracket.

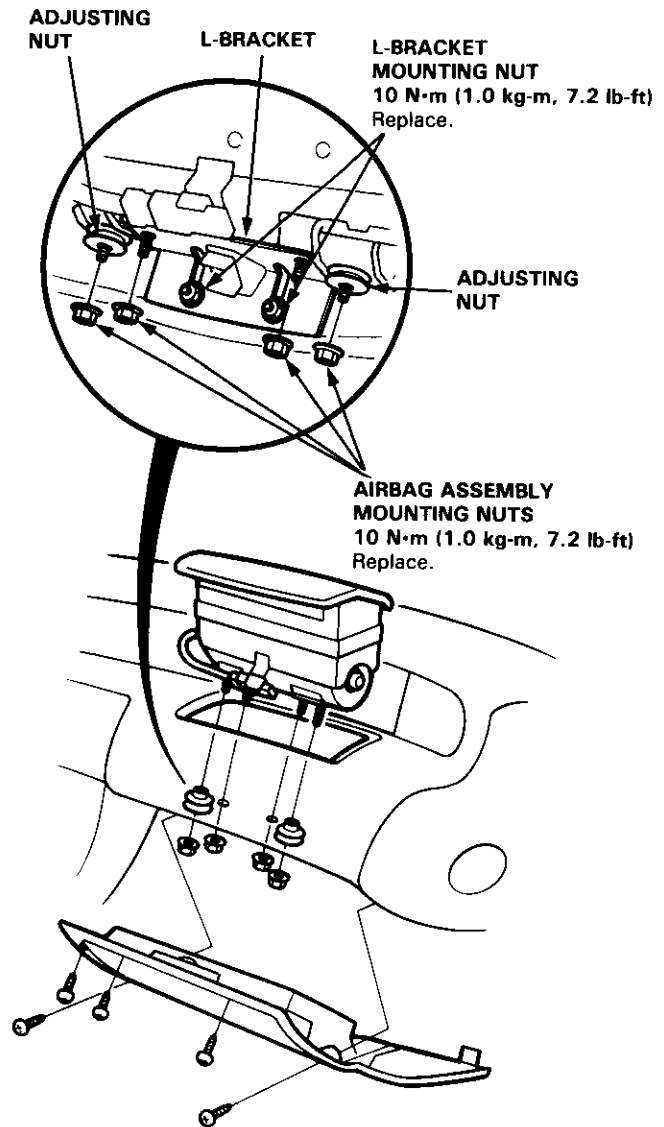



5. Remove and properly store the short connector(s), then reconnect the airbag connector(s).

Front passenger's Side:

- Attach the short connector (RED) to the connector holder.
- Then reinstall the glove box, visor, and tweeter cover on the dashboard.

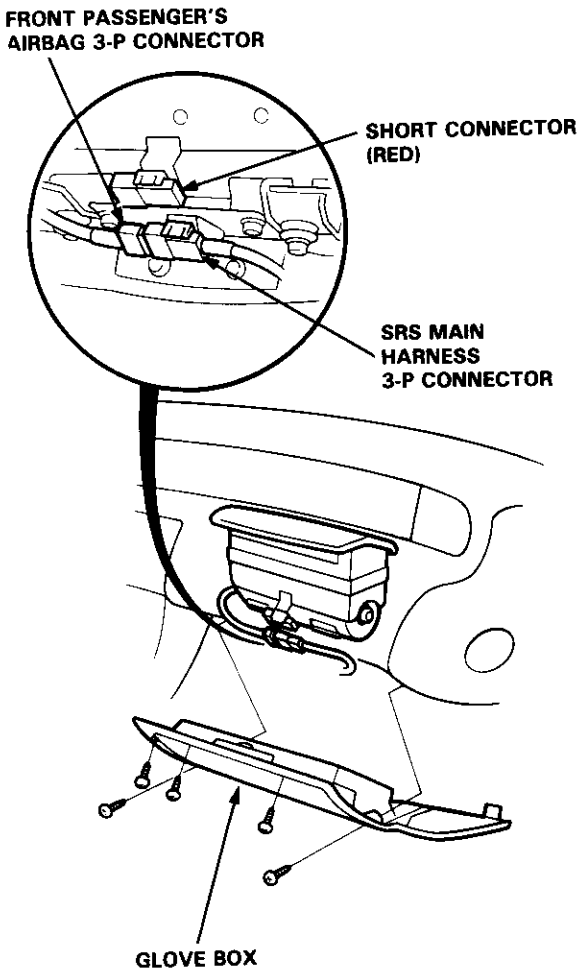

Driver's Side:

- Remove the short connector (RED) from the driver's airbag connector, then connect the airbag 3-P connector to the cable reel 3-P connector.
- Attach the short connector (RED) to the access panel, then reinstall the panel on the steering wheel.

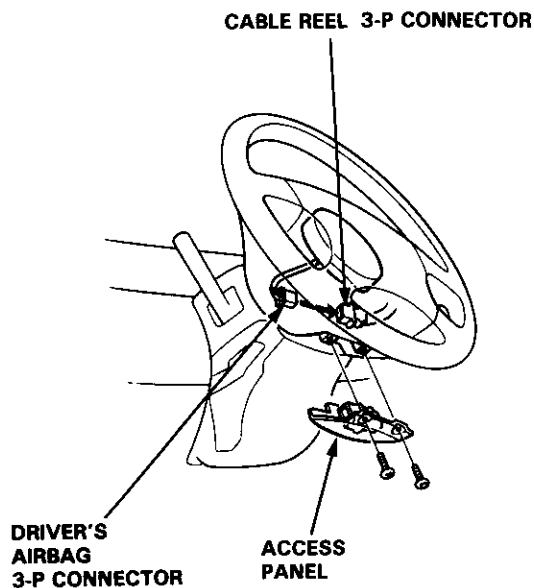

6. Connect the battery positive cable, then the negative cable.
7. After installing the airbag assembly, confirm proper system operation:
 - Turn the ignition ON (II): The instrument panel SRS indicator light should go on for about six seconds and then go off.
 - Make sure both horn buttons work.
 - Take a test drive and make sure the cruise control set/resume switch works.
8. Enter the code number to restore radio operation (see page 23-206).

Supplemental Restraint System (SRS)

Airbag Assembly Disposal

Before scrapping any airbag(s) (including one in a whole car to be scrapped) the airbag must be deployed. If the car is still within the warranty period, before you deploy the airbag, the Honda District Service Manager must give approval and/or special instructions.

Only after an airbag has been deployed (as the result of vehicle collision, for example), it can be scrapped.

If an airbag(s) appears intact (not deployed) treat it with extreme caution.

Follow this procedure:

Deploying the Airbag(s): In-Car

NOTE: If an SRS car is to be entirely scrapped, its airbag(s) should be deployed while still in the car.

The airbag(s) should not be considered as salvageable part and should never be installed in another car.

⚠ WARNING Confirm that the airbag assembly is securely mounted; otherwise severe personal injury could result during deployment.

1. Disconnect both the negative cable and positive cable from the battery.
2. Confirm that the special tool is functioning properly by following the check procedure on the label of the tool set box, or on page 23-317

Driver's Airbag:

3. Remove the access panel, then disconnect the 3-P connector between the driver's airbag and the cable reel.

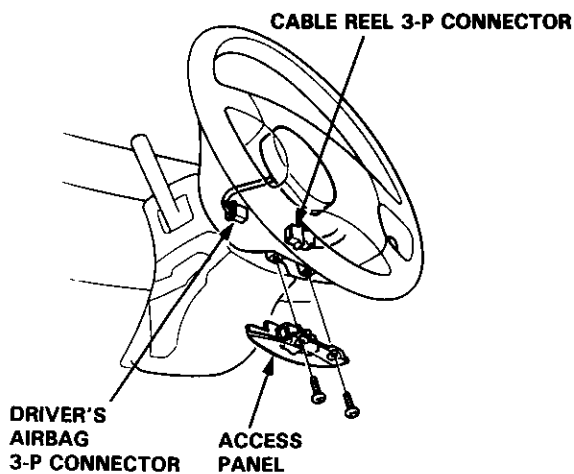

Front Passenger's Airbag:

4. Remove the glove box, then disconnect the 3-P connector between the front passenger's airbag and SRS main harness.

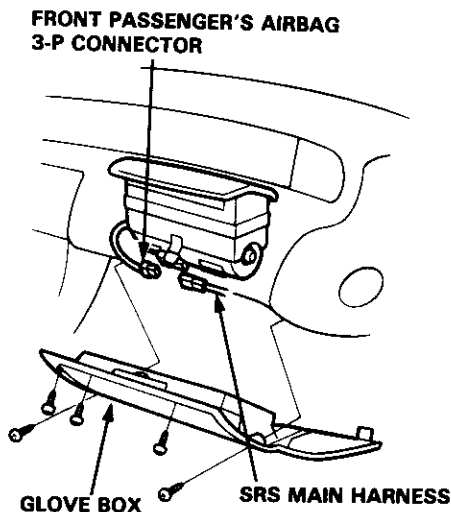

5. Cut off the airbag connector, strip the ends of the airbag, wires, and connect the special tool alligator clips to the bare wires. Place the special tool approximately thirty feet away from the airbag.

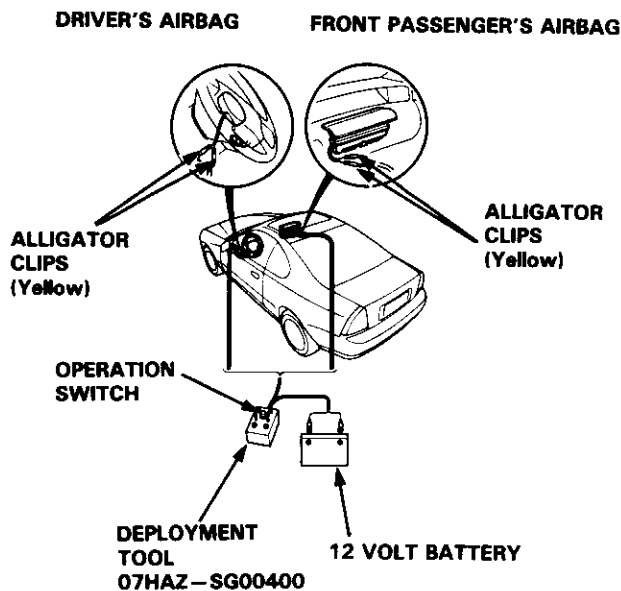

6. Connect a 12 volt battery to the tool:
 - If the green light on the tool goes on, the airbag igniter circuit is defective and cannot deploy the bag. Go to Damaged Airbag Special Procedure.
 - If the red light on the tool goes on, the airbag is ready to be deployed.

7. Push the tool's deployment switch. The airbag should deploy (deployment is both highly audible and visible – a loud noise and rapid inflation of the bag, followed by slow deflation).
 - If audible/visible deployment happens and the green light on the tool goes on, continue with this procedure.
 - If the airbag doesn't deploy, yet the green light goes ON, its igniter is defective. Go to Damaged Airbag Special Procedure.

▲WARNING During deployment, the airbag assembly can become hot enough to burn you. Wait thirty minutes after deployment before touching the assembly.

8. Dispose of the complete airbag assembly. No part of it can be reused. Place it in a sturdy plastic bag and seal it securely.

CAUTION:

- Wear a face shield and gloves when handling a deployed airbag.
- Wash your hands and rinse them well with water after handling a deployed airbag.

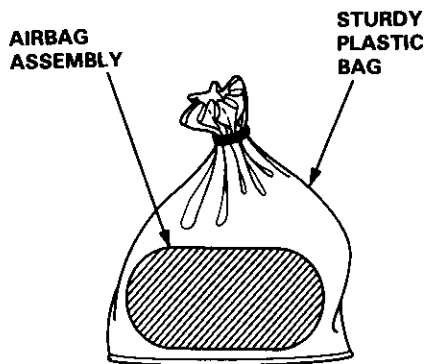

Deploying the Airbag: Out-of-car.

NOTE: If an intact airbag assembly has been removed from a scrapped car or has been found defective or damaged during transit, storage, or service, it should be deployed as follows:

▲WARNING Position the airbag assembly face up, outdoors on flat ground at least thirty feet from any obstacles or people.

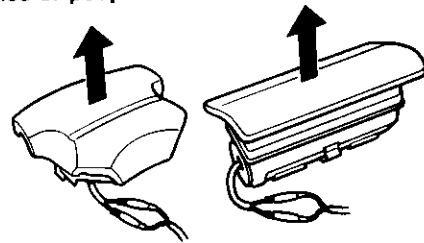

1. Confirm that the special tool is functioning properly by following the check procedure on this page or on the tool box label.
2. Remove the short connector from the airbag connector.
3. Follow steps 5, 6, 7 and 8 of the in-car deployment procedure.

Damaged Airbag Special Procedure.

▲WARNING If an airbag cannot be deployed, it should not be treated as normal scrap; it should still be considered a potentially explosive device that can cause serious injury.

1. If installed in a car, follow the removal procedure on page 23-319.
2. In all cases, make sure a short connector is properly installed on the airbag connector.
3. Package the airbag in exactly the same packaging that the new replacement part came in.
4. Mark the outside of the box "DAMAGED AIRBAG NOT DEPLOYED" so it does not get confused with your parts stock.
5. Contact your Honda District Service Manager for how and where to return it for disposal.

Deployment Tool: Check Procedure.

1. Connect the yellow clips to both switch protector handles on the tool; connect the tool to a battery.
2. Push the operation switch: green means tool is OK; red means tool is faulty.
3. Disconnect the battery and the yellow clips.

Supplemental Restraint System (SRS)

Cable Reel Replacement

WARNING Store a removed airbag assembly with the pad surface up. If the airbag is improperly stored face down, accidental deployment could propel the unit with enough force to cause serious injury.

CAUTION:

- Carefully inspect the airbag assembly before installing it. Do not install an airbag assembly that shows signs of being dropped or improperly handled, such as dents, cracks or deformation.
- Always keep the short connector(s) on the airbag(s) when the harness is disconnected.
- Do not disassemble or tamper with any airbag assembly.

NOTE: The radio may have a 5-digit coded theft protection circuit. Be sure to get the customer's code number before disconnecting the battery cable.

1. Disconnect the battery negative cable and then the positive cable.
2. Make sure the wheels are facing straight ahead.
3. Remove the dashboard lower cover, knee bolster, and air duct.

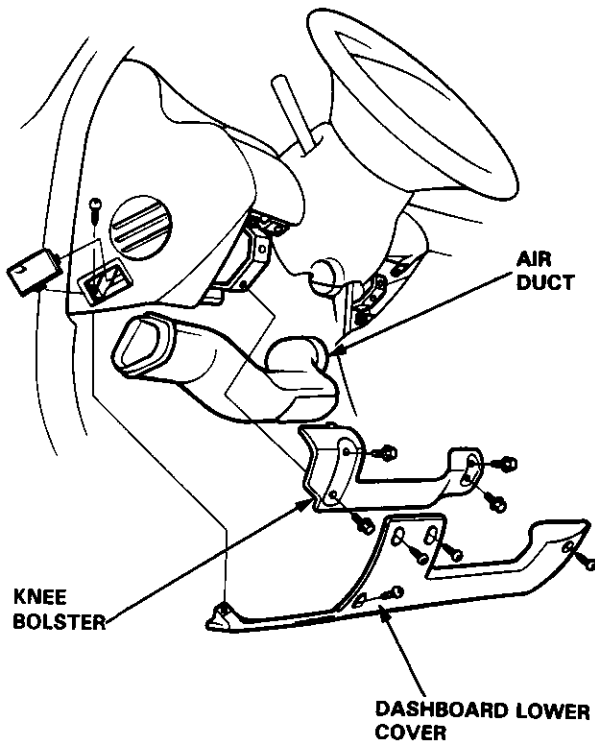

4. Install the short connector(s) on the airbag(s) (see page 23-294).

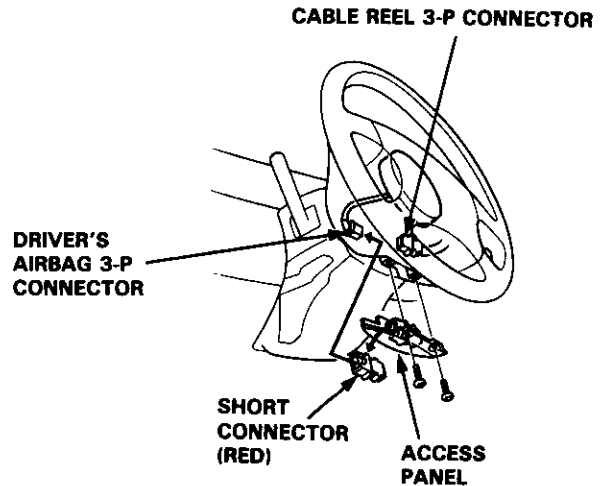

5. Remove the driver's airbag assembly from the steering wheel (two T30 TORX® bolts), then remove the steering wheel nut.

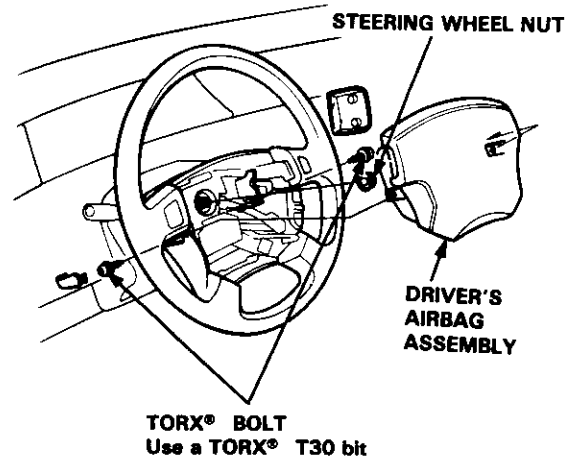



6. Disconnect the connectors from the horn and cruise control set/resume switches, then remove the cable reel 3-P connector from its clip.

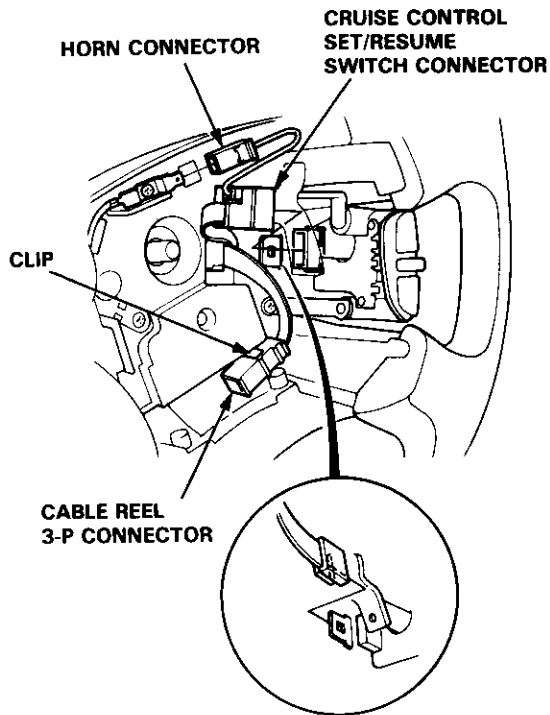

7. Remove the steering wheel from the column.
8. Remove the upper and lower column covers.

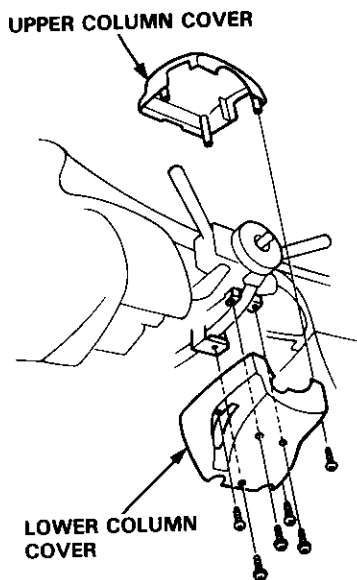

9. Disconnect the 6-P connector between the cable reel and SRS main harness, then remove the connector holder from the steering column.

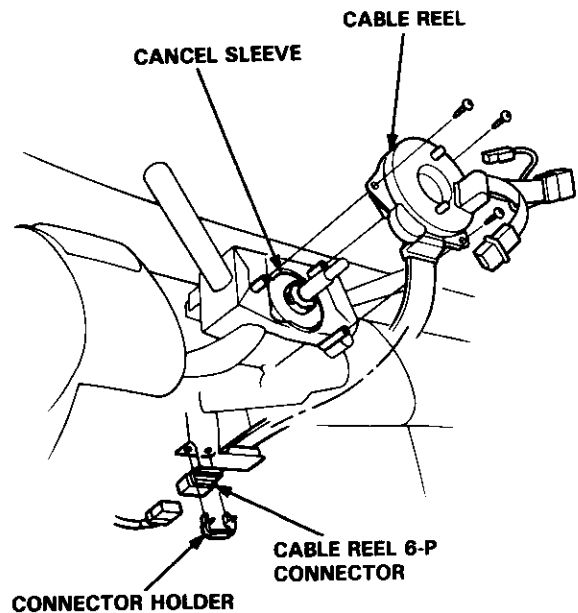

10. Remove the cable reel from the column.

(cont'd)

Supplemental Restraint System (SRS)

Cable Reel Replacement (cont'd)

CAUTION:

- Before installing the steering wheel, the front wheels should be aligned straight ahead.
- Be sure to install the harness wires so that they are not pinched or interfering with other car parts.
- After reassembly, confirm that the wheels are still straight ahead and that the steering wheel spoke angle is correct (road test). If minor spoke angle adjustment is necessary, do so only by adjustment of the tie-rods, not by removing and repositioning the steering wheel.

11. 2WS: Align the cancel sleeve grooves with the cable reel projections.

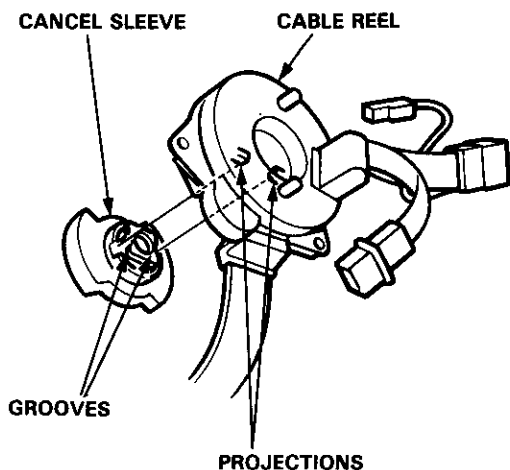

4WS: Be sure that the yellow mark on the front main steering angle sensor rotor faces downwards. If it doesn't, turn the rotor till it is in the neutral lock position (see section 17).

12. Carefully install the cable reel on the steering column shaft. Then attach the connector holder to the steering column.

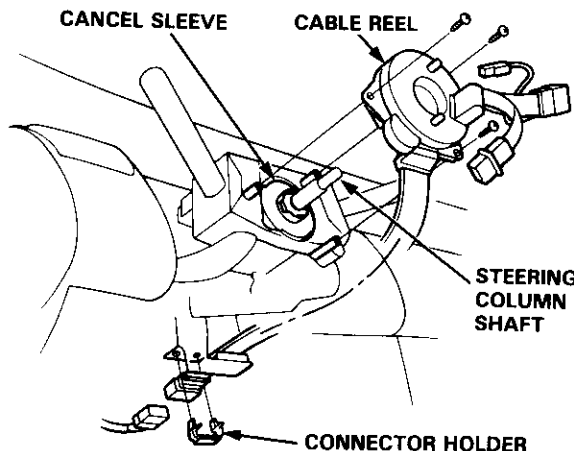

13. Install the steering column upper and lower covers.

14. Center the cable reel.

Do this by first rotating the cable reel clockwise until it stops.

Then rotate it counterclockwise (approximately two turns) until:

- The yellow gear tooth lines up with the alignment mark on the cover.
- The arrow mark on the cable reel label points straight up.

ARROW MARK

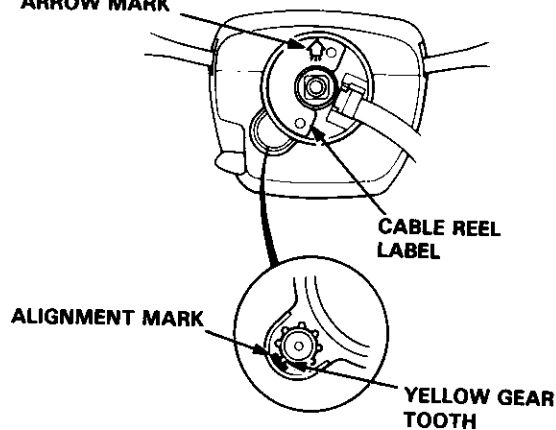

15. Install the steering wheel and attach the cable reel connector to the clip.

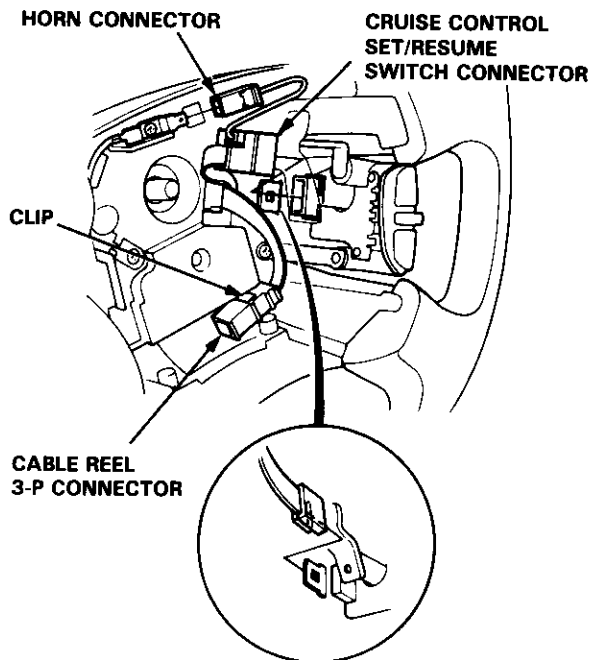

16. Connect the horn connector and cruise control set/resume switch connector.



17. Install the steering wheel nut.

NOTE: Models with 4WS
Check that the 4WS system is neutral (see section 17).

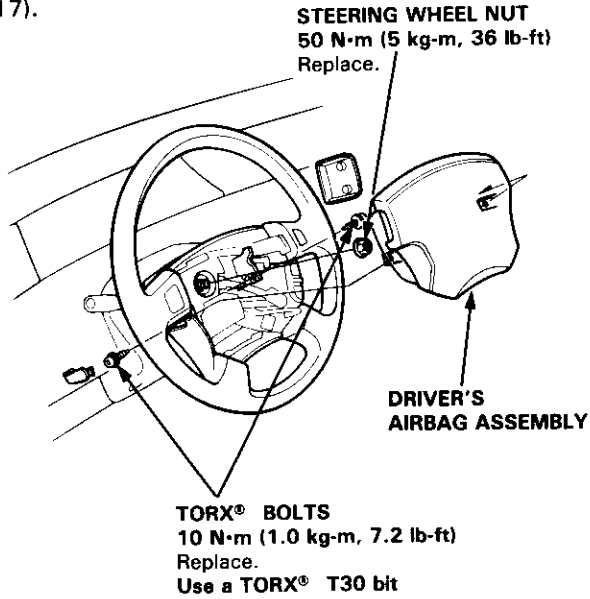

18. Install the driver's airbag assembly.

19. Connect the cable reel 6-P connector to the SRS main harness, then install the air duct, knee bolster, and dashboard lower cover.

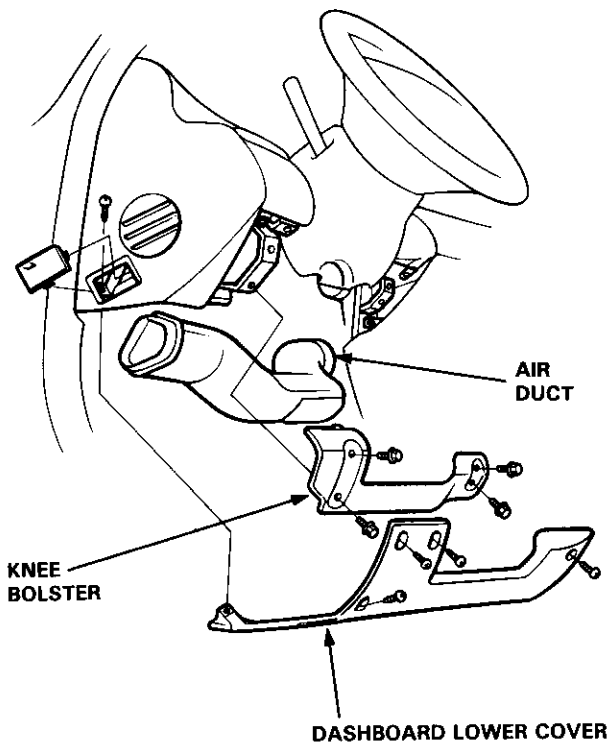

20. Remove and properly store the short connector(s) (RED), then reconnect the airbag connector(s) (and reinstall the glove box).

21. Reconnect the battery positive cable, then the negative cable.

22. After installing the cable reel, confirm proper system operation:

- Turn the ignition ON (II); the instrument panel SRS indicator light should go on for about six seconds and then go off.
- Make sure both horn buttons work.
- Make sure the headlight and wiper switches work.
- Go for a test drive and make sure the cruise control set/resume switch work.
- Rotate the steering wheel counterclockwise to make sure the yellow gear tooth lines up with the slot on the cover.

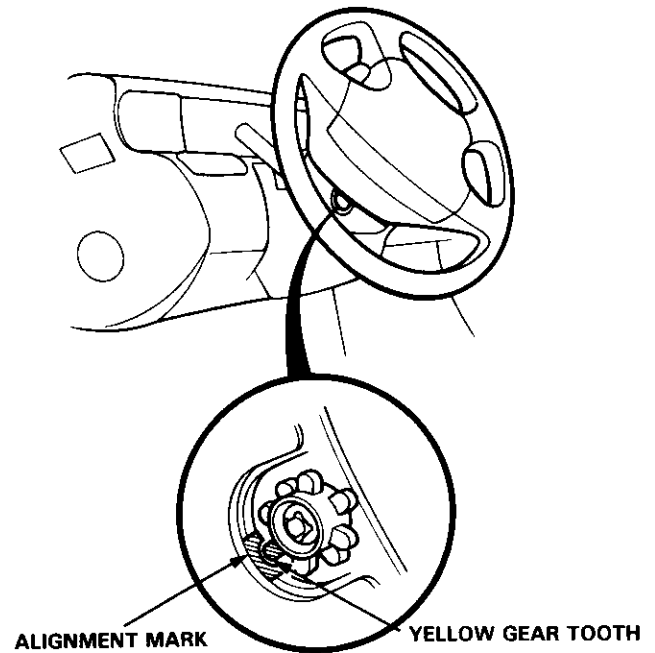

23. Enter the code number to restore radio operation (see page 23-206).

Supplemental Restraint System (SRS)

Dash Sensor Replacement

CAUTION:

- Do not damage the sensor wiring.
- Do not install used SRS parts from another car. When repairing an SRS, use only new parts.
- Replace a sensor if it is dented, cracked, or deformed.

NOTE: The radio may have a 5-digit coded theft protection circuit. Be sure to get the customer's code number before disconnecting the battery cable.

1. Disconnect the battery negative cable, then the positive cable.
2. Install the short connector(s) on the airbag(s).

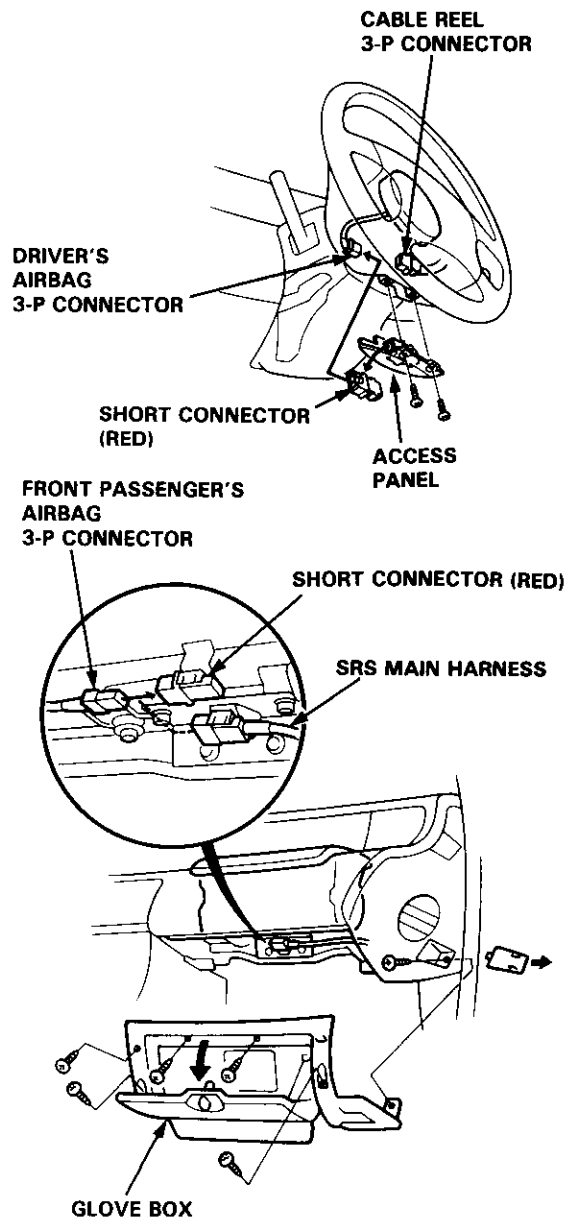

3. Left Dash Sensor:
Remove the footrest and left door sill molding, then pull the carpet back.

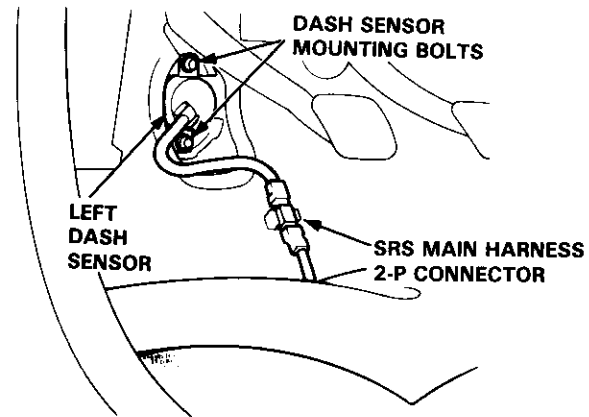

4. Right Dash Sensor:
Remove the right door sill molding and pull back the carpet. Remove the ECM.

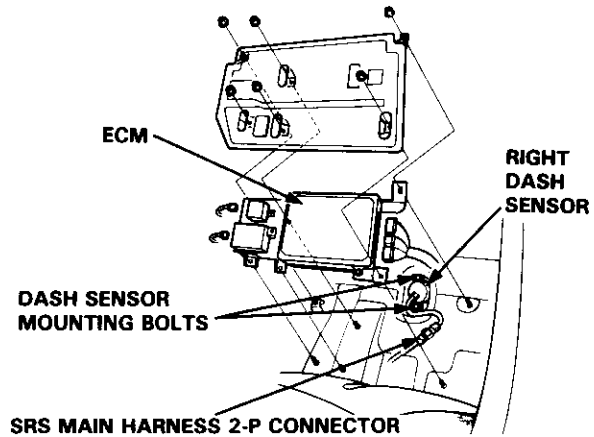

5. Remove the two mounting bolts, then remove the left or right dash sensor.

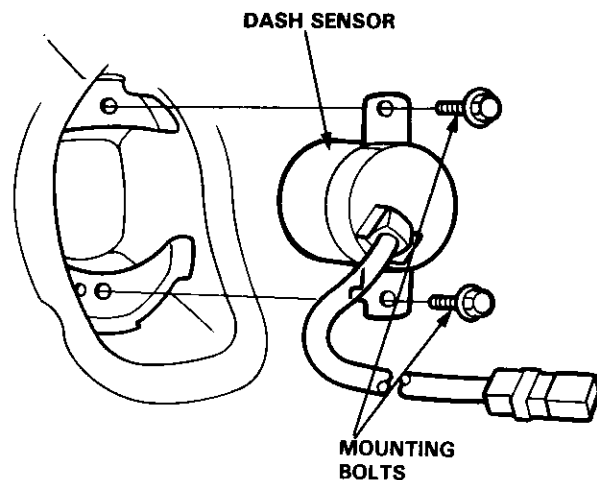

CAUTION:

- Be sure to install the harness wires so they are not pinched or interfering with other car parts.
- Carefully inspect the new dash sensor(s) for signs of being dropped or improperly handled, such as dents, cracks or deformation.
- For the SRS to function properly, the right and left sensors must be installed on the proper sides.

6. Install the sensor securely.

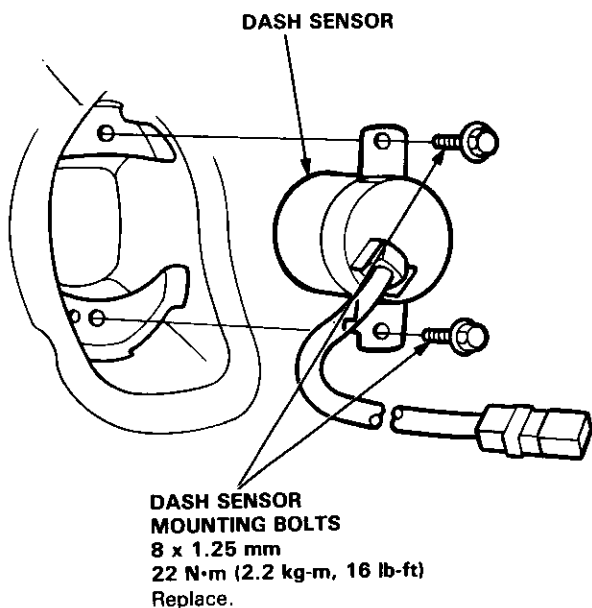

7. Reinstall all other removed parts.

8. Remove and properly store the short connector(s) (RED), then reconnect to airbag connector(s) (and reinstall the glove box).

9. Reconnect the battery positive cable, then the negative cable.

10. After installing the dash sensor, confirm proper system operation: Turn the ignition ON (II); the instrument panel SRS indicator light should go on for about six seconds and then go off.

11. Enter the code number to restore radio operation (see page 23-206).

Supplemental Restraint System (SRS)

SRS Unit Replacement

CAUTION:

- Before disconnecting any part of the SRS wire harness, install the short connector(s) on the airbag(s).
- Do not damage the SRS unit terminals or connectors.
- Do not disassemble the SRS unit; it has no serviceable parts.
- Store the SRS unit in a clean, dry area.
- Do not use any SRS unit which has been subjected to water damage or shows signs of being dropped or improperly handled, such as dents, cracks or deformation.

NOTE: The radio may have a 5-digit coded theft protection circuit. Be sure to get the customer's code number before disconnecting the battery cable.

1. Disconnect the battery negative cable, then the positive cable.
2. Install the short connector(s) on the airbag(s) (see page 23-294).
3. Remove the right side cover from the SRS unit.

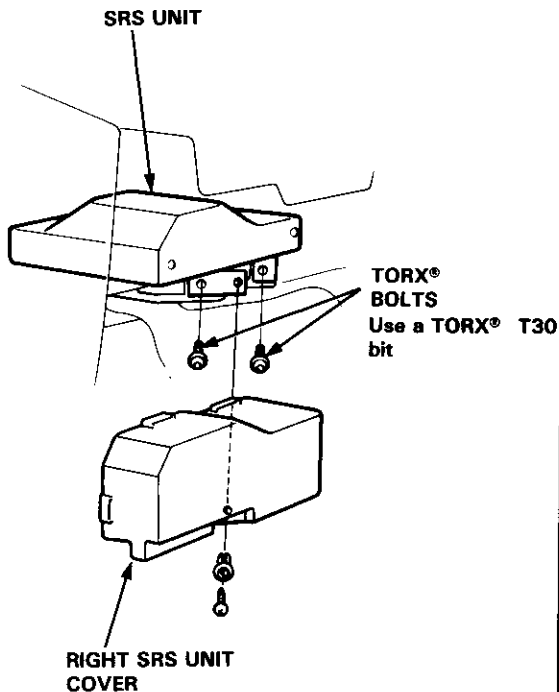

4. Remove the left side cover from the SRS unit, then disconnect the SRS main harness 18-P connector from the SRS unit.

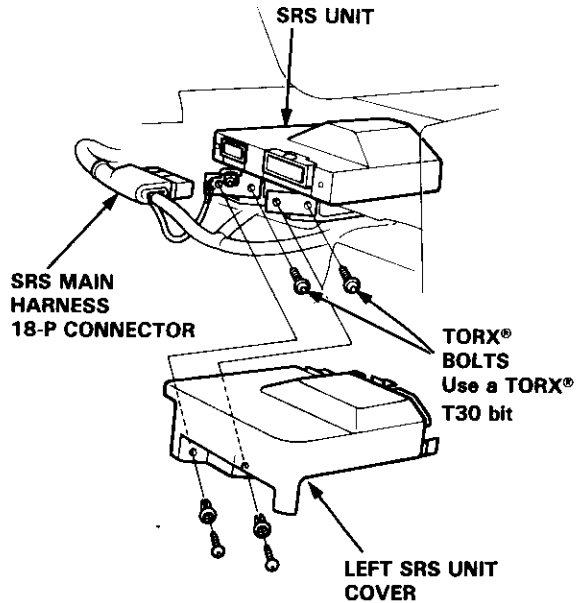

5. Remove the four SRS unit TORX® bolts, then pull the SRS unit out from the driver's side.



CAUTION: Be sure to install the SRS wiring so that it is not pinched or interfering with other car parts.

6. Install the new SRS unit.

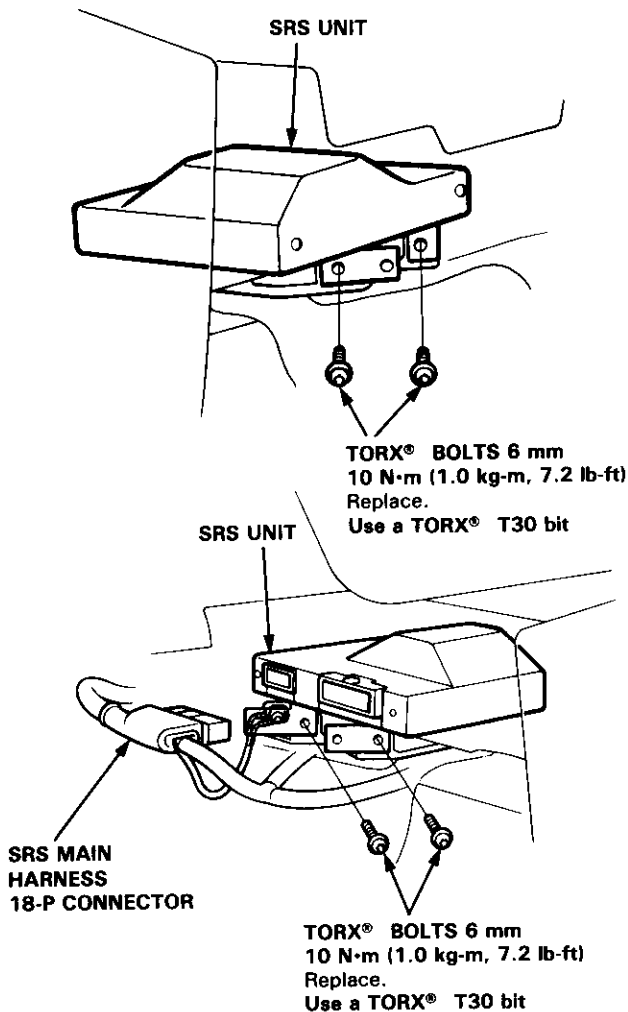

7. Connect the SRS main harness 18-P connector to the SRS unit; push it into position until it clicks.
8. Install the SRS unit covers (right and left).

9. Remove and properly store the short connector(s) (RED), then reconnect the airbag connector(s) (and reinstall the glove box).
10. Reconnect the battery positive cable, then the negative cable.
11. After installing the SRS unit, confirm proper system operation: Turn the ignition to II; the instrument panel SRS indicator light should go on for about six seconds and then go off.
12. Enter the code number to restore radio operation (see page 23-206).